

Water Heater

Thermo Top Evo Parking Heater



With FuelFix

Installation Documentation Subaru Outback



SUBARU

Validity

Manufacturer	Model	Type	EG BE No. / ABE
Subaru	Outback	B6	e1 * 2007 / 46 * 1320 *...

Motorisation	Fuel	Transmission type	Output in kW	Displacement in cm ³	Engine code
2.0D	Diesel	6-speed SG	110	1998	EE20
2.0D	Diesel	CVT	110	1998	EE20
2.5P	Petrol	CVT	129	2498	FB25

SG = manual transmission
CVT = Lineartronic transmission

From model year 2015
Left-hand drive vehicle

Verified equipment variants: 2 zone automatic air-conditioning
Front fog lights
Daytime running lights
4 WD
LED headlight with headlight washer system
Euro 6 emission standard
Keyless access

Not verified: Passenger compartment monitoring

Total installation time: about 8.6 hours

Subaru Outback

Table of Contents

Validity	1	Preparing Installation Location	15
Necessary Components	2	Preparing Heater	16
Installation Overview	2	Installing Heater	18
Information on Total Installation Time	2	Coolant Circuit	19
Information on Operating and Installation Instructions	3	Coolant System Integration for Diesel Vehicles	20
Information on Validity	4	Coolant System Integration for Petrol Vehicles	23
Technical Information	4	Combustion Air	26
Explanatory Notes on Document	4	Fuel	27
Preliminary Work	5	FuelFix Installation for Diesel Vehicles	30
Heater Installation Location	5	FuelFix Installation for Petrol Vehicles	32
Preparing Electrical System	6	Exhaust Gas	35
Electrical System	8	Final Work	40
Automatic Air-Conditioning Fan Controller	10	Template for Bracket	41
MultiControl CAR Option	13	FuelFix Template	42
Remote Option (Telestart)	13	Operating Instructions for Automatic A/C	43
ThermoCall Option	14		

Necessary Components

- Basic delivery scope of Thermo Top Evo based on price list
Subaru part number for diesel vehicle: **1166_**
Subaru part number for petrol vehicle: **1165**
- Installation kit for Subaru Outback 2015 Petrol and diesel: **1324223B**
Subaru part number: **1166-04**
- Heater control in accordance with price list and upon consultation with end customer
- In case of Telestart, indicator lamp in accordance with price list and in consultation with end customer
- In case of MultiControl CAR installation: MultiControl installation frame: **9030077_**
Subaru part number: **9965-27**

Installation instructions:

- Arrange for the vehicle to be delivered with the tank only about ¼ full!
- The installation location of the push button in case of Telestart or Thermo Call should be confirmed with the end customer.
- Depending on the space required and the vehicle manufacturer's instructions, we recommend the use of a vehicle battery with a higher electrical capacity.

Installation Overview

Legend:

1. Heater
2. Engine compartment fuse holder
3. Passenger compartment relay and fuse holder
4. Circulating pump
5. MultiControl CAR
6. Metering pump
7. FuelFix

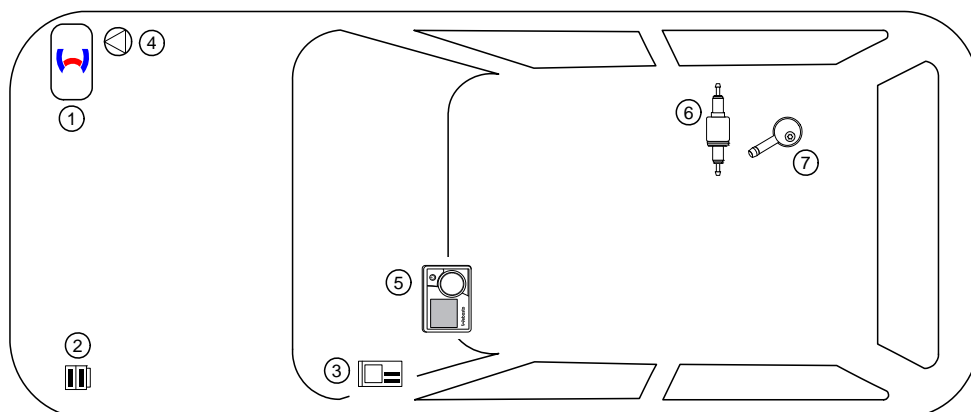

Information on Total Installation Time

The total installation time includes the time needed for mounting and demounting the vehicle-specific components, the heater specific installation time and all other times required for the system integration and initial start-up of the heater. The total installation time may vary for vehicle equipment other than provided.

Information on Operating and Installation Instructions

1 Important information (not complete)

1.1 Installation and repair



The improper installation or repair of Webasto heating and cooling systems can cause fire or the leakage of deadly carbon monoxide, leading to serious injury or death.



To install and repair Webasto heating and cooling systems you need to have completed a special company training course and have the appropriate technical documentation, special tools and special equipment.



Installation and repair may ONLY be carried out by persons trained and certified in a Webasto training course. NEVER try to install or repair Webasto heating or cooling systems if you have not completed a Webasto training course, you do not have the necessary technical skills and you do not have the technical documentation, tools and equipment available to ensure that you can complete the installation and repair work properly.

Only use genuine Webasto parts. See the Webasto air and water heaters accessories catalogue for this purpose.

1.2 Operation

To ensure safe operation, we recommend having the heater checked every two years by an authorised Webasto dealer, especially when used over a long period and/or under extreme environmental conditions.

Do not operate the heater in closed rooms due to the danger of poisoning and suffocation.

Always switch off the heater before refuelling.

The heater may only be used with the prescribed fuel diesel (DIN EN 590) or petrol (DIN EN 228).

The heater may not be cleaned with a high-pressure cleaner.

1.3 Please note

ALWAYS follow all Webasto installation and operating instructions and observe all warnings.

To become familiar with and understand all functions and properties of the heater, the operating instructions must be read carefully and observed at all times.

For proper, safe installation and repair work, the installation instructions with all warnings and safety information must be carefully read and observed at all times. Please always contact a workshop authorised by Webasto for all installation and repair work.

Important

Webasto shall assume no liability for defects, damage and injuries resulting from a failure to observe the installation, repair and operating instructions of the information contained in them.

This liability exclusion particularly applies to improper installations and repairs, installations and repairs by untrained persons or in the case of a failure to use genuine spare parts.

The liability due to culpable disregard to life, limb or health and due to damage or injuries caused by a wilful or reckless breach of duty remain unaffected, as does the obligatory product liability.

Installation should be carried out according to the general, standard rules of technology. Unless specified otherwise, fasten hoses, lines and wiring harnesses to original vehicle lines and wiring harnesses using cable ties. Insulate loose wire ends and tie back. Connectors on electronic components have to audibly click into place during installation.

Sharp edges should be fitted with rub protection. Spray unfinished body areas, e.g. drilled holes, with anti-corrosion wax (Tectyl 100K).

Observe the instructions and guidelines of the respective vehicle manufacturer for demounting and mounting vehicle specific components!

The initial startup is to be executed with the Webasto Thermo Test Diagnosis.

When installing a programmable control module (e.g. a PWM Gateway), the corresponding settings must be checked or adjusted.

2 Statutory regulations governing installation

Guidelines	Thermo Top Evo
Heating Directive ECE R122	E1 00 0258
EMC Directive ECE R10	E1 04 5627

Note

The regulations of these guidelines are binding in the scope of the Directive 70/156/EEC and/or 2007/46/EC (for new vehicle models from 29/04/2009) and should also be observed in countries in which there are no special regulations.

Important

Failure to follow the installation instructions will result in the invalidation of the type approval for the heater and therefore invalidation of the general **homologation of the vehicle**.

Note

The heater is licensed in accordance with paragraph 19, section 3, No. 2b of the StVZO (German Road Traffic Licensing Authority).

2.1 Excerpt from ECE regulation 122 (heating system) paragraph 5 for the installation of the heater

Beginning of excerpt.

ANNEX VII

REQUIREMENTS FOR COMBUSTION HEATERS AND THEIR INSTALLATION

1. GENERAL REQUIREMENTS

1.7.1. A clearly visible tell-tale in the operator's field of view shall inform when the combustion heater is switched on or off.

2. VEHICLE INSTALLATION REQUIREMENTS

2.1. Scope

2.1.1. Subject to paragraph 2.1.2, combustion heaters shall be installed according to the requirements of this Annex.

2.1.2. Vehicles of category O having liquid fuel heaters are deemed to comply with the requirements of this Annex.

2.2. Positioning of heater

2.2.1. Body sections and any other components in the vicinity of the heater must be protected from excessive heat and the possibility of fuel or oil contamination.

2.2.2. The combustion heater shall not constitute a risk of fire, even in the case of overheating. This requirement shall be deemed to be fulfilled if the installation ensures an adequate distance to all parts and suitable ventilation, by the use of fire resistant materials or by the use of heat shields.

2.2.3. In the case of M2 and M3 vehicles, the heater must not be positioned in the passenger compartment. However, an installation in an effectively sealed envelope which also complies with the conditions in paragraph 2.2.2 may be used.

2.2.4. The label referred to in paragraph 1.4 or a duplicate, must be positioned so that it can be easily read when the heater is installed in the vehicle.

2.2.5. Every reasonable precaution should be taken in positioning the heater to minimise the risk of injury and damage to personal property.

2.3. Fuel supply

2.3.1. The fuel filler must not be situated in the passenger compartment and must be provided with an effective cap to prevent fuel spillage.

2.3.2. In the case of liquid fuel heaters, where a supply separate to that of the vehicle is provided, the type of fuel and its filler point must be clearly labelled.

2.3.3. A notice, indicating that the heater must be shut down before refuelling, must be affixed to the fuelling point. In addition a suitable instruction must be included in the manufacturer's operating manual.

2.4. Exhaust system

2.4.1. The exhaust outlet must be located so as to prevent emissions from entering the vehicle through ventilators, heated air inlets or opening windows.

2.5. Combustion air inlet

2.5.1. The air for the combustion chamber of the heater must not be drawn from the passenger compartment of the vehicle.

2.5.2. The air inlet must be so positioned or guarded that blocking by rubbish or luggage is unlikely.

2.6. Heating air inlet

2.6.1. The heating air supply may be fresh or recirculated air and must be drawn from a clean area not likely to be contaminated by exhaust fumes emitted either by the propulsion engine, the combustion heater or any other vehicle source.

2.6.2. The inlet duct must be protected by mesh or other suitable means.

2.7. Heating air outlet

2.7.1. Any ducting used to route the hot air through the vehicle must be so positioned or protected that no injury or damage could be caused if it were to be touched.

2.7.2. The air outlet must be so positioned or guarded that blocking by rubbish or luggage is unlikely.

End of excerpt.

In multilingual versions the German language is binding.

Subaru Outback

Information on Validity

This installation documentation applies to Subaru Outback Petrol and diesel vehicles - for validity, see page 1 - from model year 2015 and later, assuming technical modifications to the vehicle do not affect installation, any liability claims excluded. Depending on the vehicle version and equipment, modifications may be necessary during installation with respect to this 'installation documentation'.

Vehicle and engine types, equipment variants and other specifications not listed in this installation documentation have not been tested. However, installation according to this installation documentation may be possible.

Technical Information

Special Tools

- Hose clamp pliers for auto-tightening hose clamps
- Hose clamp pliers for Clic hose clamps of type W
- Automatic wire stripper 0.2 - 6mm²
- Crimping pliers for cable lug / tab connector 0.5 - 6mm²
- Torque wrench for 2.0 - 10 Nm
- Hose clamping pliers
- Metric thread-setter kit
- Deep-hole marker
- Webasto Thermo Test Diagnosis with current software

Dimensions

- All dimensions are in mm.

Tightening torque values

- Tightening torque values of 5x13 heater bolts and 5x11 heater stud bolts = 8Nm.
- Tightening torque value of 5x15 water connection piece retaining plate bolt = 7Nm.
- Tighten other bolt connections in accordance with manufacturer's instructions or in accordance with state-of-the-art technology.

Explanatory Notes on Document

You will find an identification mark on the outside top right corner of the page in question to provide you with a quick overview of the individual working steps.

Special features are highlighted using the following symbols:

Mechanical System



Electrical System



Coolant Circuit



Combustion Air



Fuel



Exhaust Gas



Software



Specific risk of damage to components.



Specific risk due to electrical voltage.



Specific risk of injury or fatal accidents.



Specific risk of fire or explosion.



Reference to the manufacturer's vehicle-specific documents or to the general installation instructions of Webasto components.



Reference to a special technical feature.



The arrow in the vehicle icon indicates the position on the vehicle and the viewing angle.



Tightening torque according to the manufacturer's vehicle-specific documents.



Subaru Outback

Preliminary Work

Vehicle



- Open the fuel tank cap.
- Ventilate the fuel tank.
- Close the fuel tank cap again.
- Depressurise the cooling system.
- Remove the battery.
- Remove the engine cover.
- Remove the air filter completely, together with the intake connection piece.
- Remove the engine underdrive protection.
- Remove the underdrive protection of the transmission (if present).
- Remove the underbody trim on the right side, remove the trim on the tank on the right side.
- Remove the bumper trim.
- Remove the rear bench seat.
- Open the tank-fitting service lid on the right and left.
- Remove the lateral instrument panel trim on the left.
- Remove the lateral instrument panel trim on the right.
- Remove the lower instrument panel trim on the front passenger's side.
- Remove the instrument panel trim on the driver's side.
- Remove the speaker cover on the left side of the instrument panel (only in case of Telestart or ThermoCall).
- Remove the glove box.

Heater

- Remove years that do not apply from the type and duplicate label.
- Attach the duplicate label (type label) visibly in the appropriate place in the engine compartment.

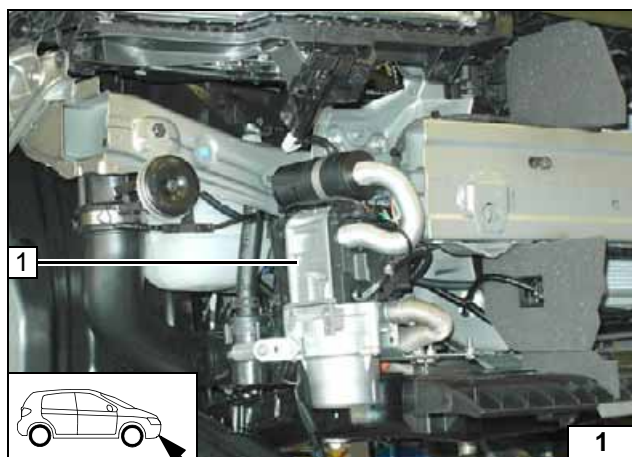

Heater Installation Location

- 1 Heater

Installation location

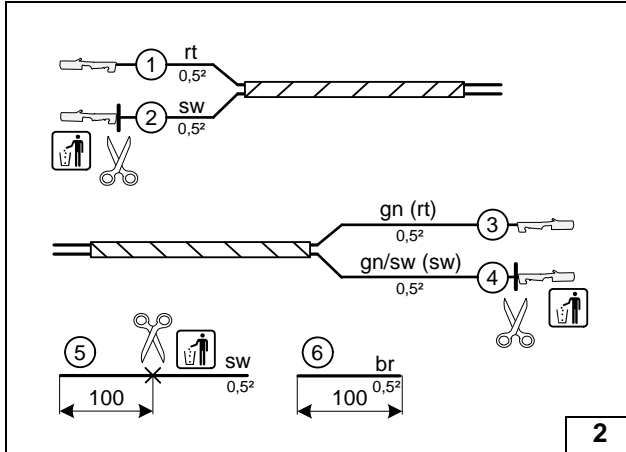

Preparing Electrical System

Wire sections retain their numbering in the entire document.

Produce all following electrical connections as shown in the wiring diagram.

- ① Red (rt) wire of fan controller wiring harness
- ② Black (sw) wire of fan controller wiring harness
- ③ Green or red (gn/rt) wire of A/C control wiring harness
- ④ Green/black (gn/sw) or black (sw) wire of A/C control wiring harness

Cutting to length / assigning wires

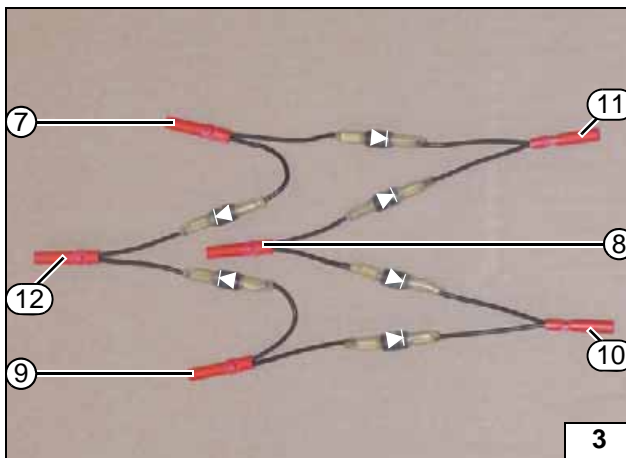

Premount six diodes with shrinkable connectors on diode group D1 as shown. Watch direction of flow of diodes.

Premounting / assigning diode group

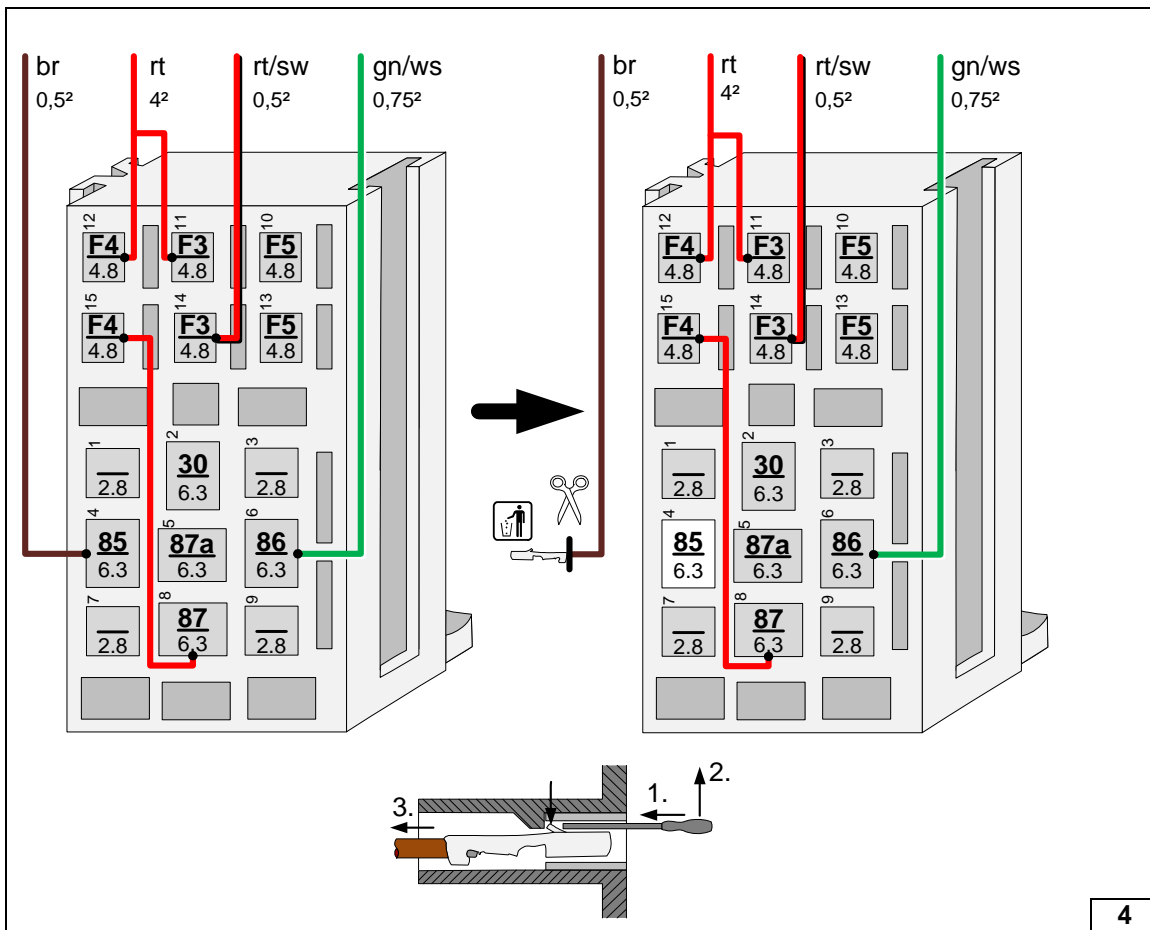

Preparing passenger compartment relay and fuse holder

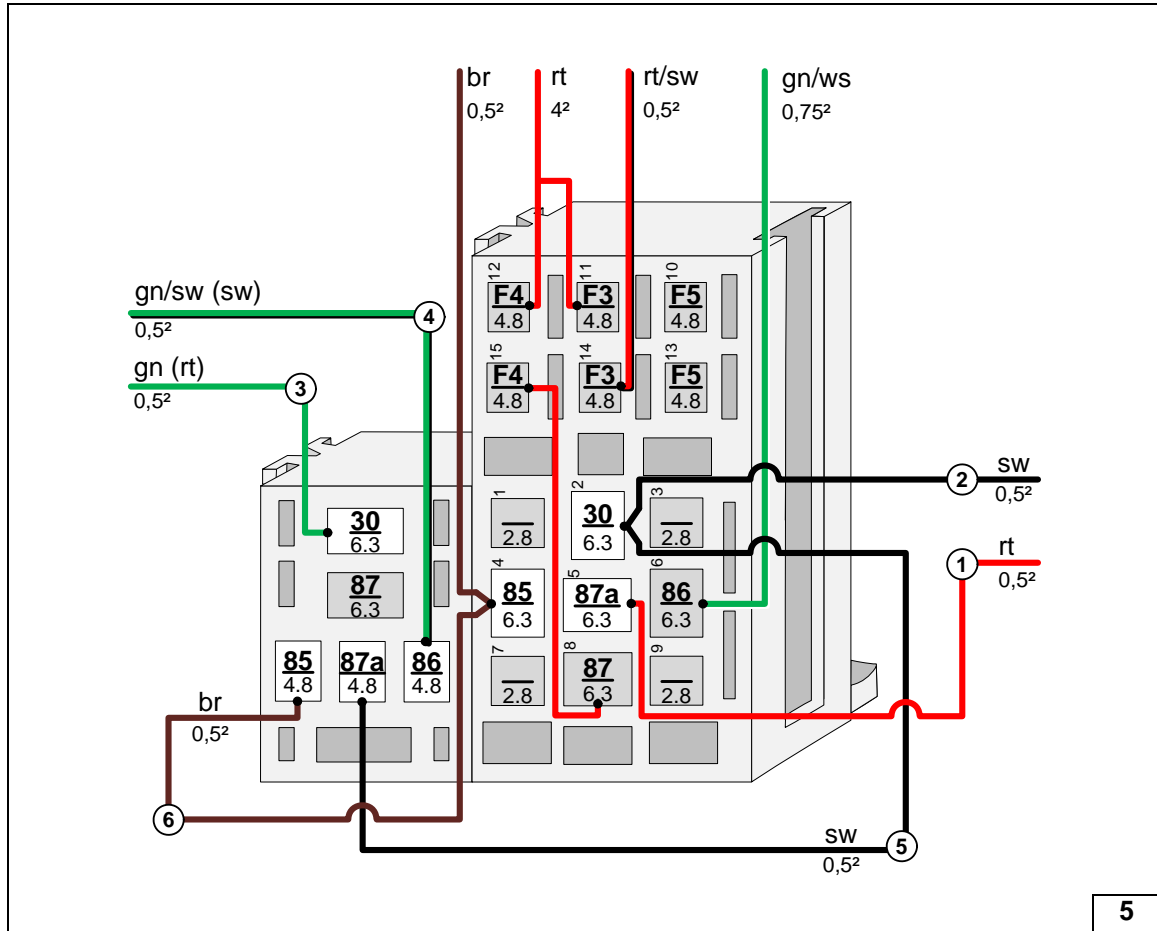

Interlocking relay K2 socket and passenger compartment relay and fuse holder, connecting wires

5



Electrical System



Engine compartment fuse holder

Remove original vehicle plastic plug at position 2 and discard.

- 1 Fuses F1-2
- 2 M5x16 bolt, large diameter washer [2x], retaining plate of fuse holder, nut

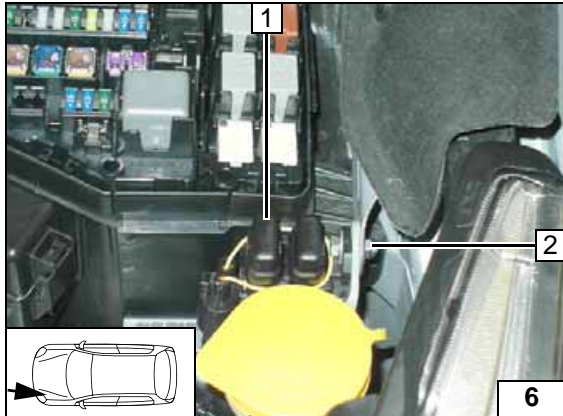

Wiring harness pass through

- 1 Protective rubber plug
- 2 Heater wiring harness, heater control

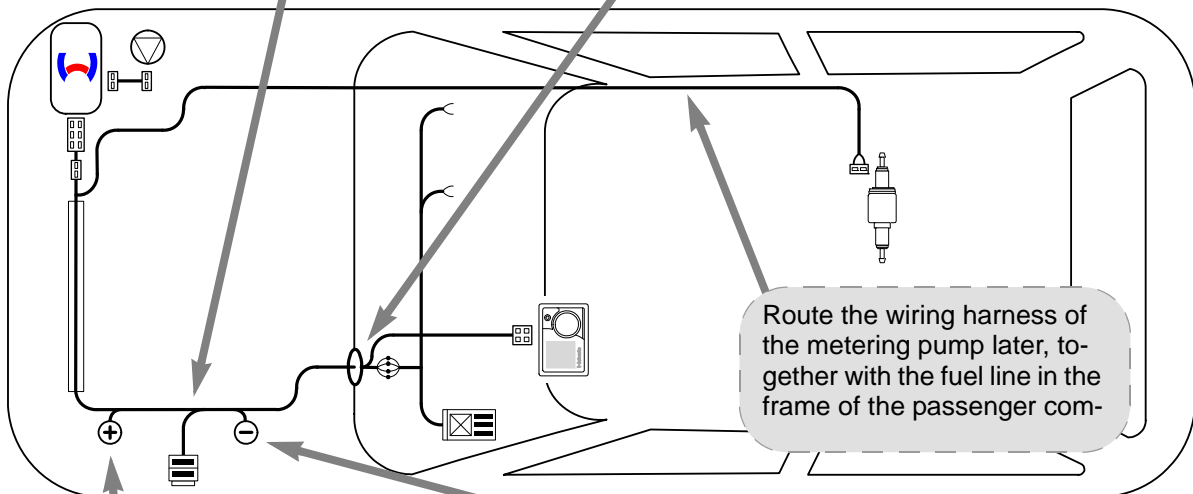
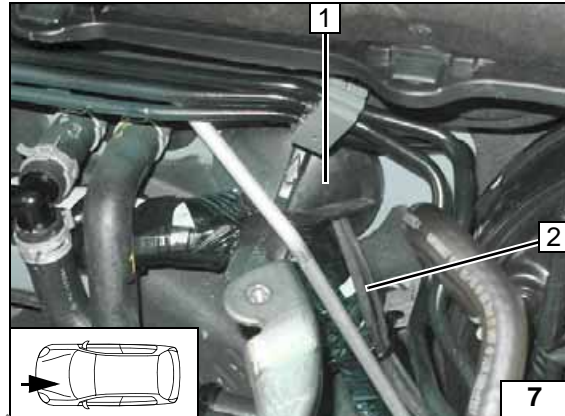

Wiring harness routing diagram

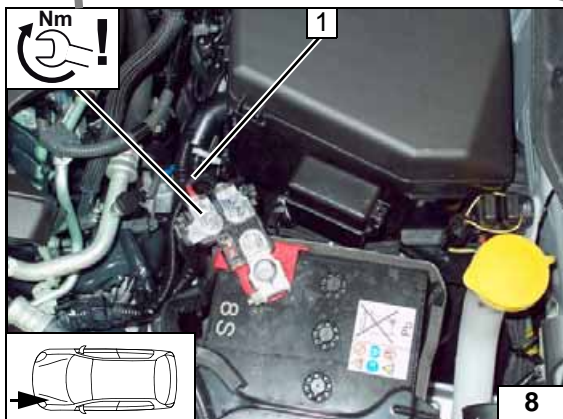

Positive wire

- 1 Positive wire on positive battery distributor

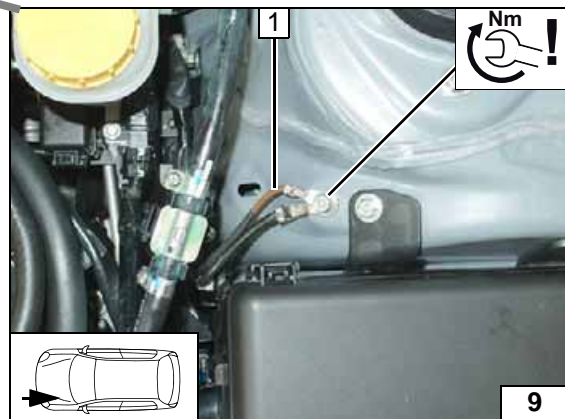

Earth wire

- 1 Earth wire on original vehicle earth support point



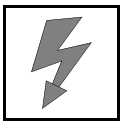

Slit open 10mm dia. corrugated tube, insert heater wiring harness, position using cable ties (see next figure) and tighten after heater connection.

Routing wiring harness

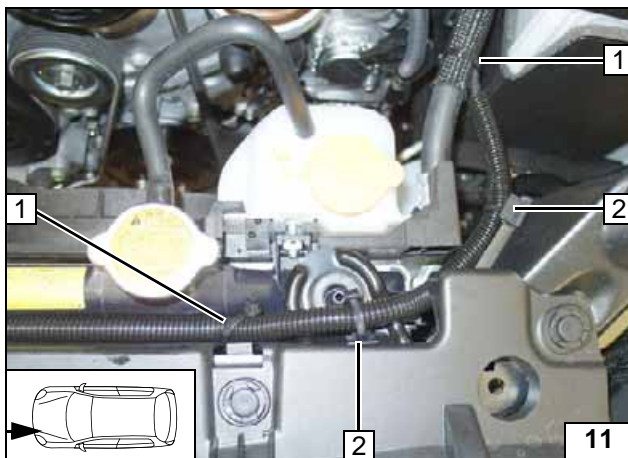

- 1 Cable tie [2x]
- 2 Cable tie with clip [2x]

Routing wiring harness

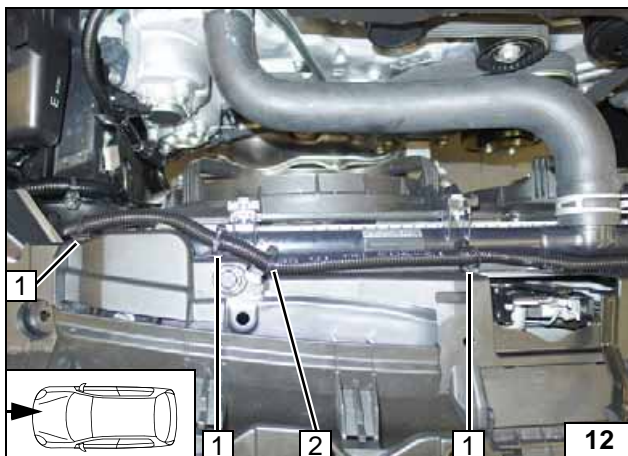

- 1 Cable tie with clip [3x]
- 2 Cable tie

Routing wiring harness



Automatic Air-Conditioning Fan Controller

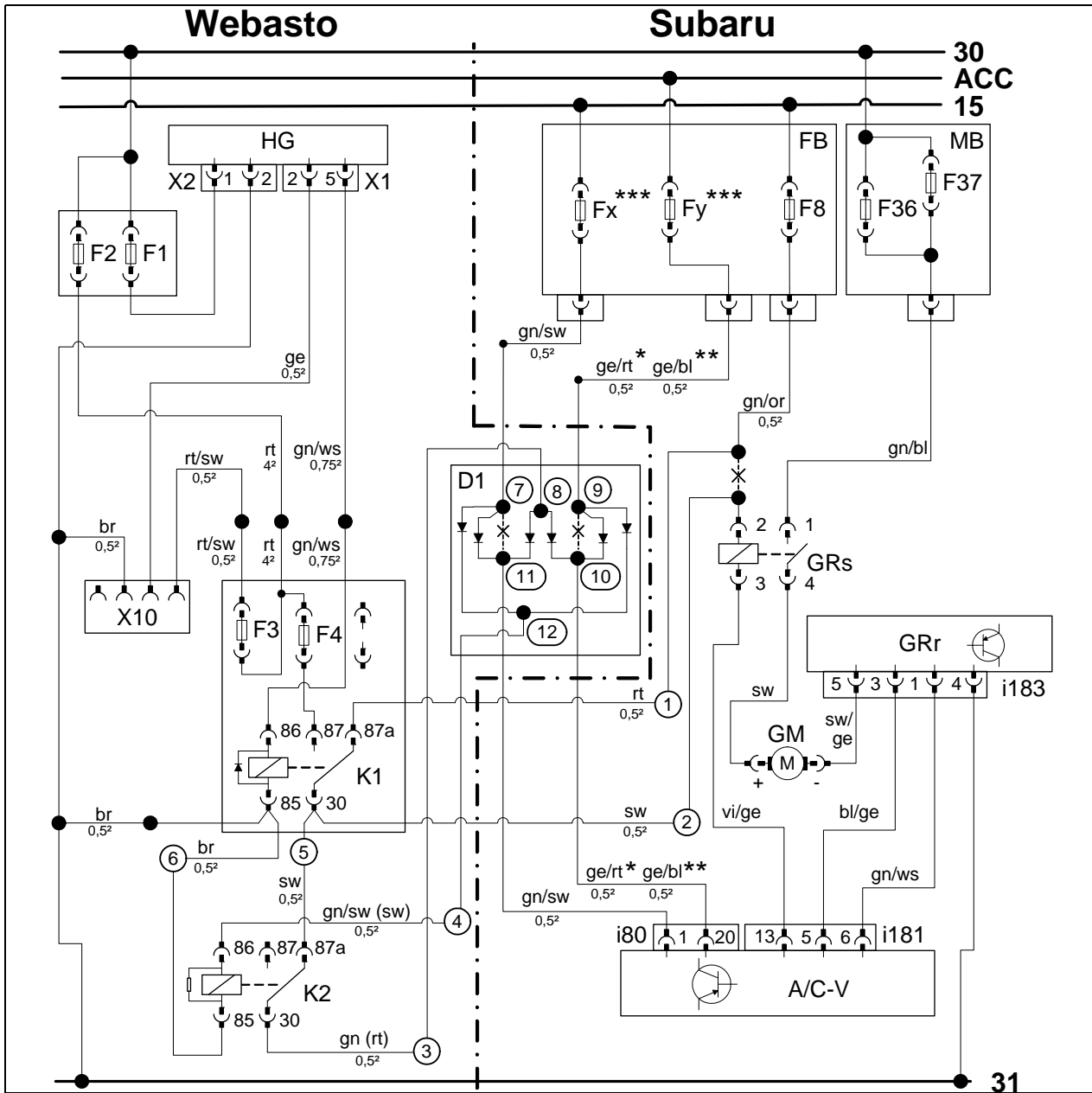

Wiring diagram

Webasto components		Vehicle components		Colours and symbols	
HG	TT-Evo heater	FB	Passenger compartment fuses	rt	red
X1	6-pin heater connector	Fx	Fuse	ws	white
X2	2-pin heater connector	Fy	Fuse	sw	black
F1	20A fuse	F8	15A fuse	br	brown
F2	30A fuse	MB	Engine compartment fuses	gn	green
D1	Diode group	F36	15A fuse	bl	blue
X10	4-pin connector of heater control	F37	15A fuse	ge	yellow
F3	1A fuse	GRs	Fan relay	vi	violet
F4	5A fuse	GRr	Fan controller	or	orange
K1	Fan relay	i183	5-pin connector of GRr	*	Diesel Petrol vehicle without Start/Stop
K2	Isolating relay	GM	Fan motor	**	Petrol vehicle with Start/Stop
		A/C-V	A/C booster	***	The designation may vary.
		i80	26-pin connector of A/C-V	X	Cutting point
		i181	24-pin connector of A/C-V		Wiring colours may vary.

Legend

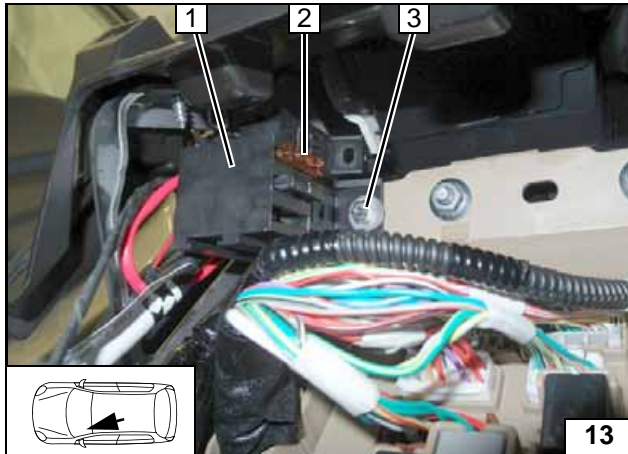

- 1 Passenger compartment relay and fuse holder
- 2 5A fuse F4
- 3 M5x16 bolt, large diameter washer [2x], existing hole, nut

Installing passenger compartment relay and fuse holder

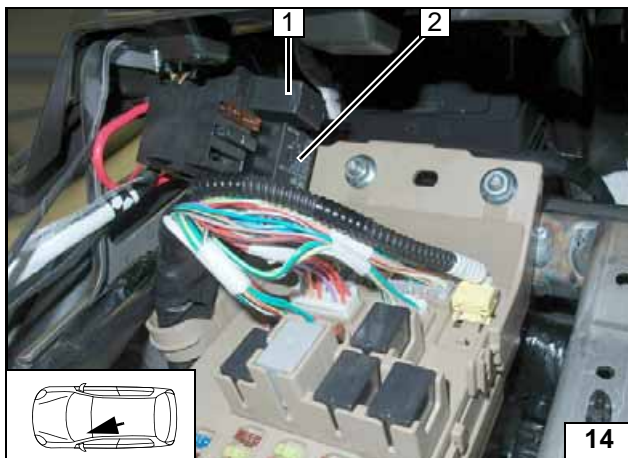

- 1 Relay K2
- 2 Relay K1

Installing relay

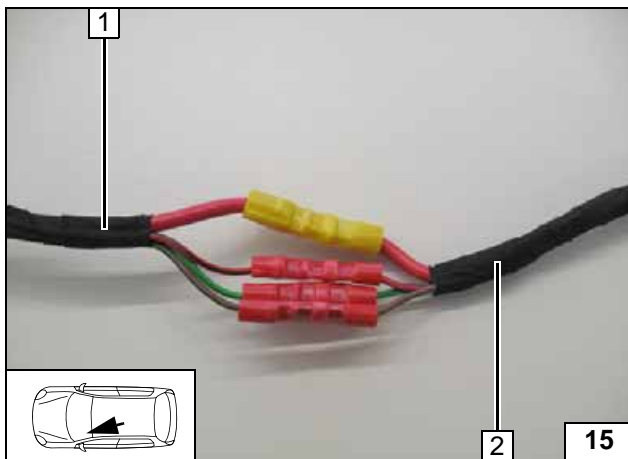

- 1 Passenger compartment relay and fuse holder wiring harness
- 2 Wiring harness of heater

Connecting same colour wires of wiring harnesses

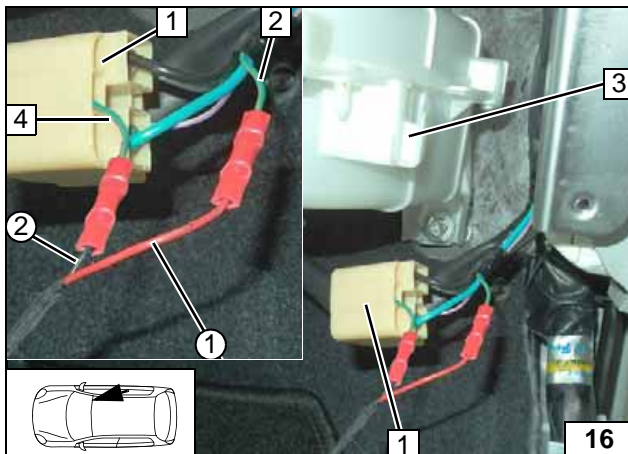

Hang original vehicle fan relay with connector 1 onto bracket 3. Remove relay, will be reinserted after the installation.

- 2 Green/orange (gn/or) wire of fuse F8 from passenger compartment fuse box
- 4 Green/orange (gn/or) wire of GRs
- ① Red (rt) wire of K1/87a from fan controller wiring harness
- ② Black (sw) wire of K1/30 from fan controller wiring harness

Connection to fan relay



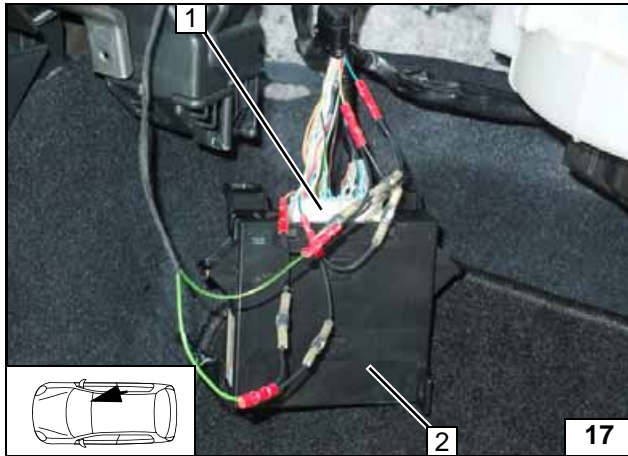

Remove A/C booster 2 and expose connector i80 1.



Overall view of A/C booster connection

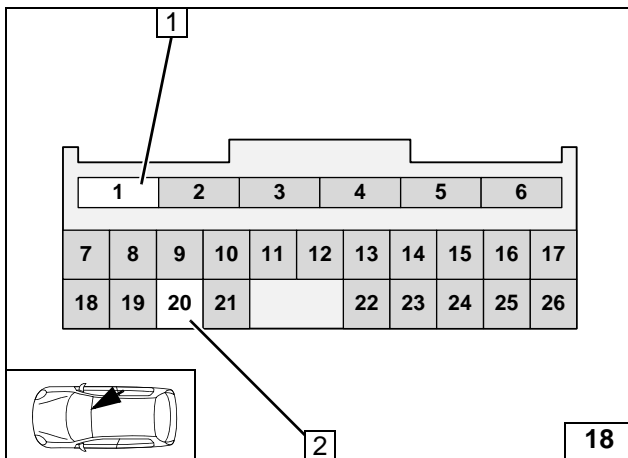

- 1 Green/black (sw) wire / pin 1
- 2 Yellow/red (ge/rt) wire / pin 20 (diesel / petrol vehicle without Start/Stop system), yellow/blue (ge/bl) wire / pin 20 (petrol vehicle with Start/Stop system)

View of connector i80 on contact side

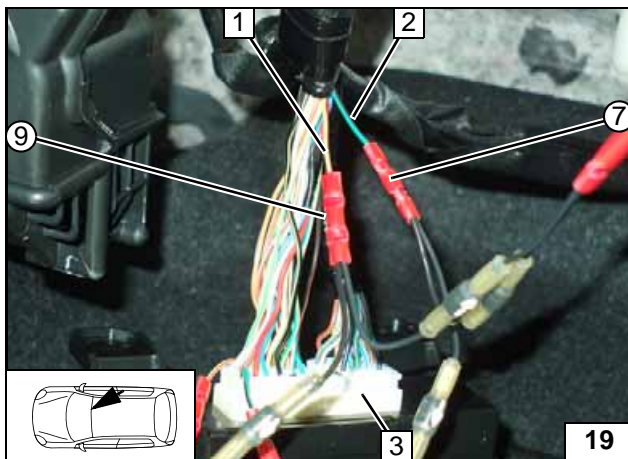

Shrink the butt connector after the installation.



Connection of A/C booster

- 1 Yellow/red (ge/rt) wire of fuse Fy (diesel / petrol vehicle without Start/Stop system). Yellow/blue (ge/bl) wire of fuse Fy (petrol vehicle with Start/Stop system)
- 2 Green/black (gn/sw) wire of fuse Fx
- 3 26-pin connector i80/ A/C booster

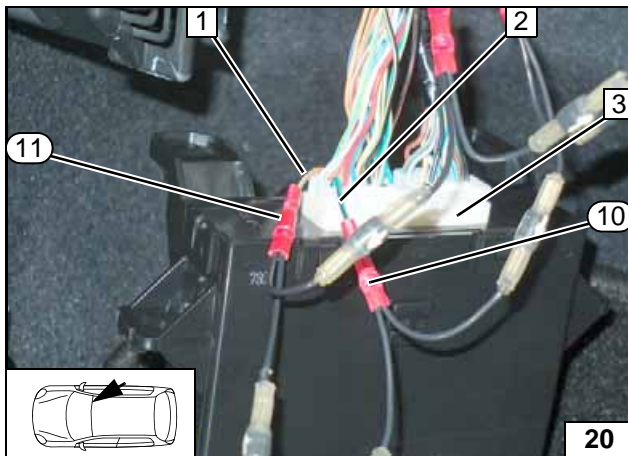

Shrink the butt connector after the installation.



Connection of A/C booster

- 1 Green/black (gn/sw) wire of connector i80, pin 1
- 2 Yellow/red (ge/rt) wire of connector i80 / pin 20 (diesel / petrol vehicle without Start/Stop system), yellow/blue (ge/bl) wire of connector i80 / pin 20 (petrol vehicle with Start/Stop system)
- 3 26-pin connector i80/ A/C booster

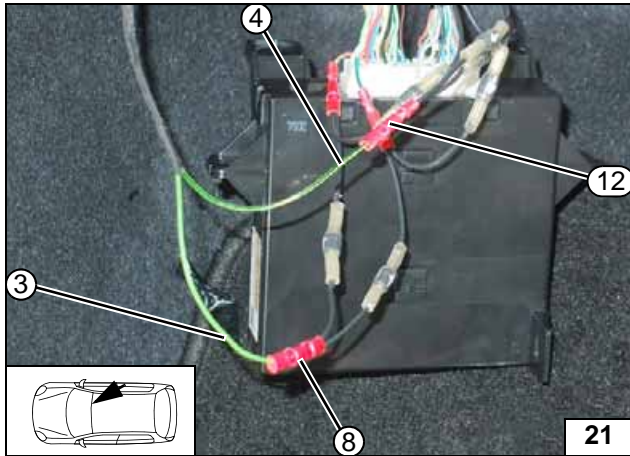
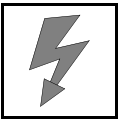

Shrink the butt connector after the installation.



Connect-
ing diode
group

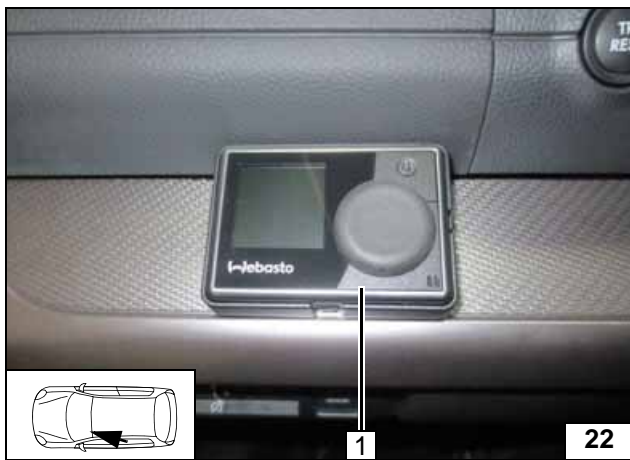

MultiControl CAR Option

- 1 MultiControl CAR



Installing
MultiControl
CAR

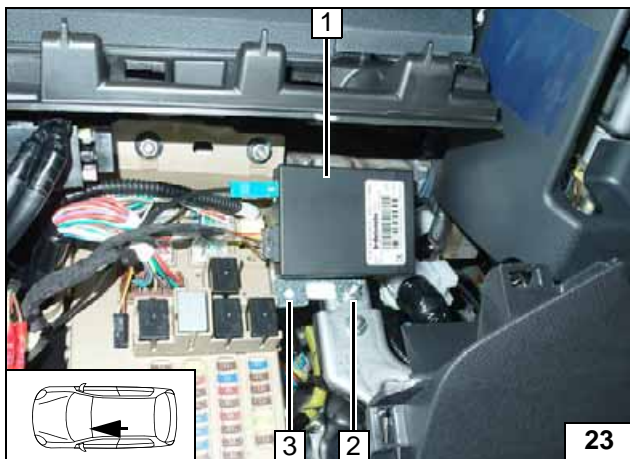

Remote Option (Telestart)

- 1 Receiver
- 2 M5x16 bolt, washer, original vehicle hole, flanged nut
- 3 Receiver bracket



Installing
receiver

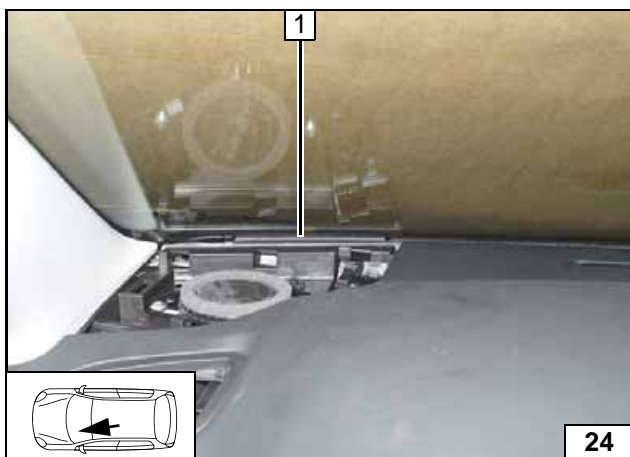

- 1 Aerial

Installing
aerial

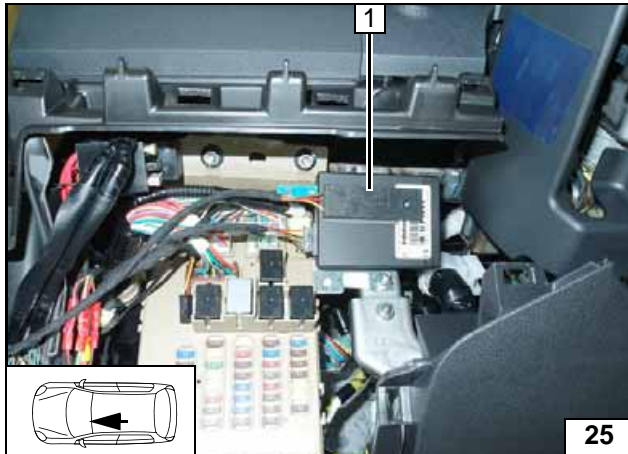

Temperature sensor T100 HTM

Fasten temperature sensor 1 with double-sided adhesive tape.



Installing temperature sensor

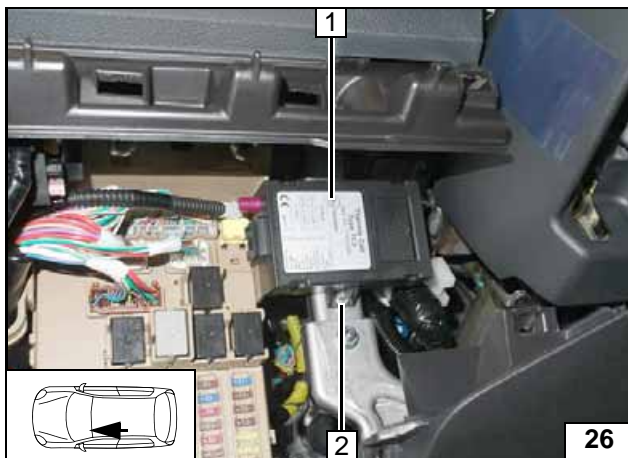

ThermoCall Option

- 1 Receiver
- 2 M5x16 bolt, washer, original vehicle hole, flanged nut



Installing receiver

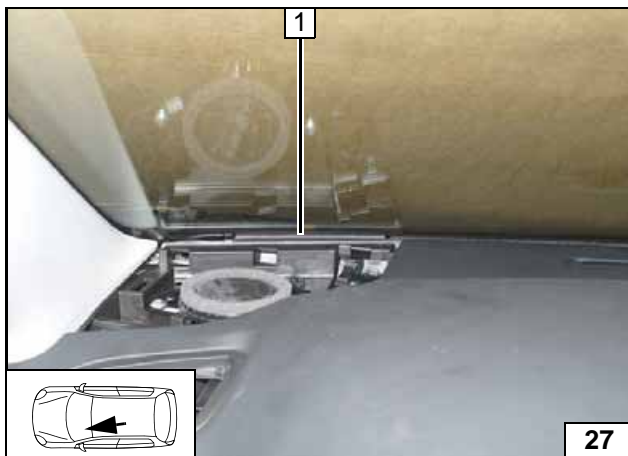

- 1 Aerial (optional)

Installing aerial

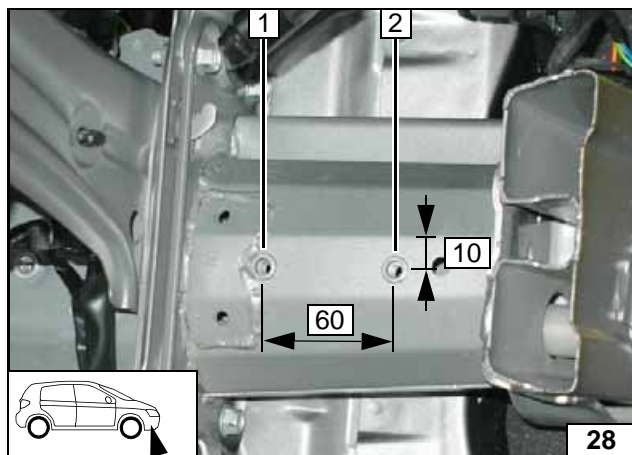

Preparing Installation Location

- 1 Drill out existing hole to 9.1 mm dia., rivet nut
- 2 Copy hole pattern, 9.1 mm dia. hole, rivet nut



Drilling hole, inserting rivet nut

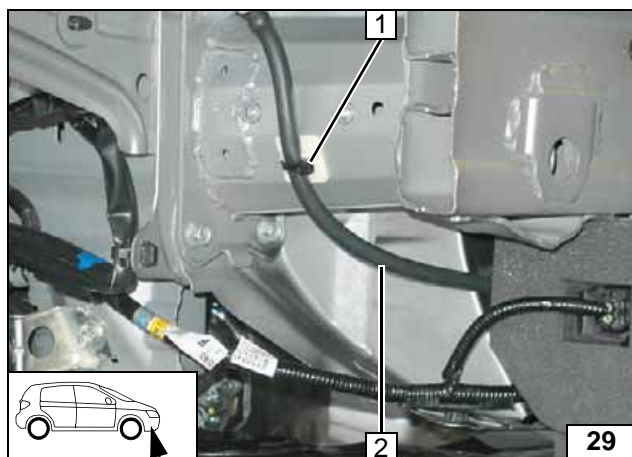

Degrease bonding surface.

- 1 Adhesive base with cable tie
- 2 Hose of headlight washer system



Routing hose of headlight washer system

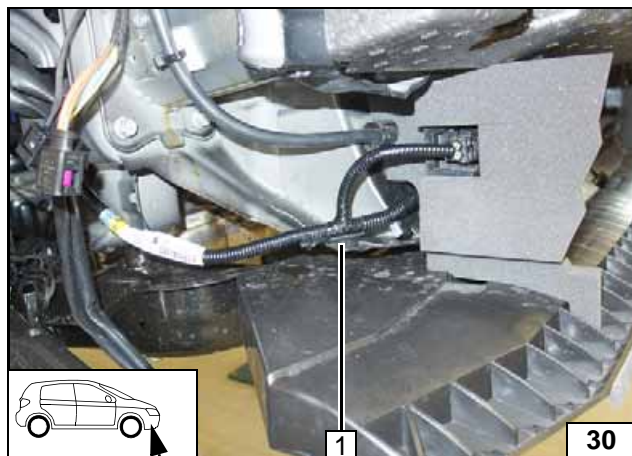

- 1 Unclip wiring harness

Repositioning wiring harness

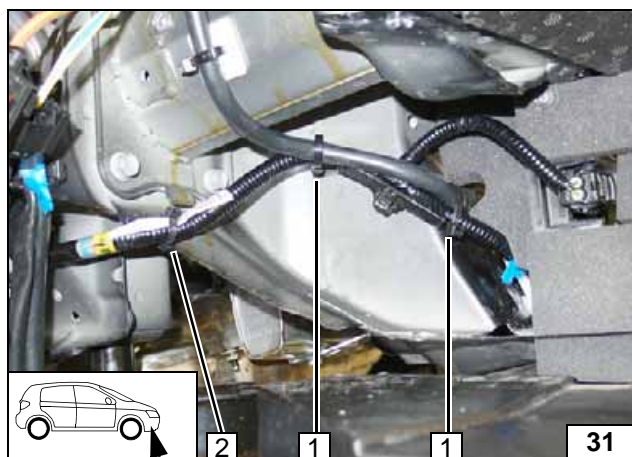

- 1 Cable tie [2x]
- 2 Cable tie with clip

Repositioning wiring harness

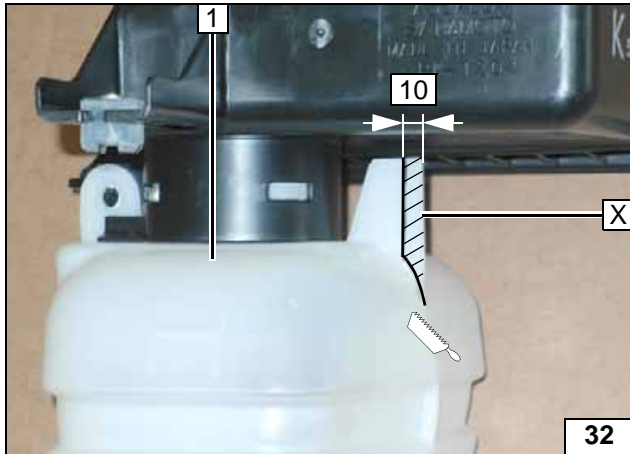
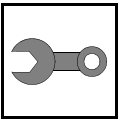

Diesel only

Remove marked area of resonator 1 as shown.

X =



Adapting resonator

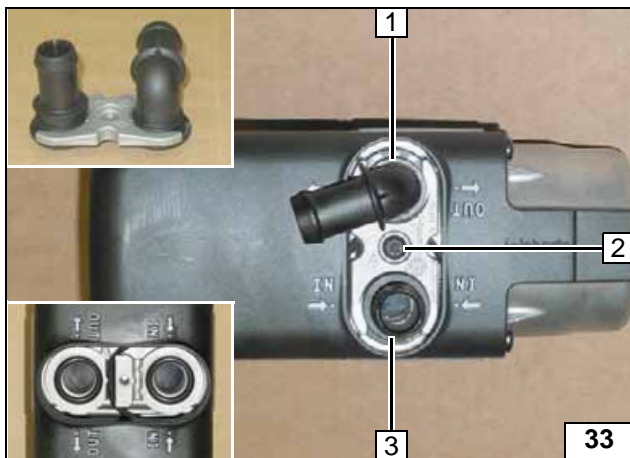

Preparing Heater

All vehicles

- 1 90° water connection piece, sealing ring
- 2 5x15 self-tapping bolt, retaining plate of water connection piece
- 3 Axial water connection piece, sealing ring



Installing water connection piece

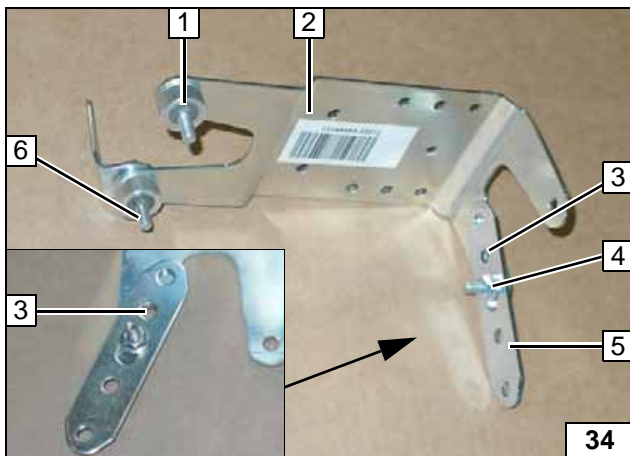

Bend and drill holes in bracket 2 according to template. Align hole of perforated bracket and hole of bracket at position 3 congruently

- 1 M6x30 bolt, spring lockwasher, 10mm shim, pin lock
- 4 M6x20 bolt, flanged nut
- 5 Perforated bracket
- 6 M6x30 bolt, spring lockwasher, angle bracket, 10mm shim, pin lock



Premounting bracket

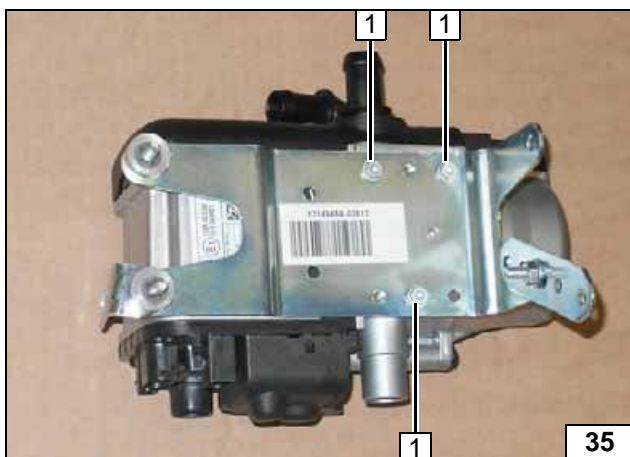

- 1 5x13 self-tapping bolts [3x]

Installing bracket

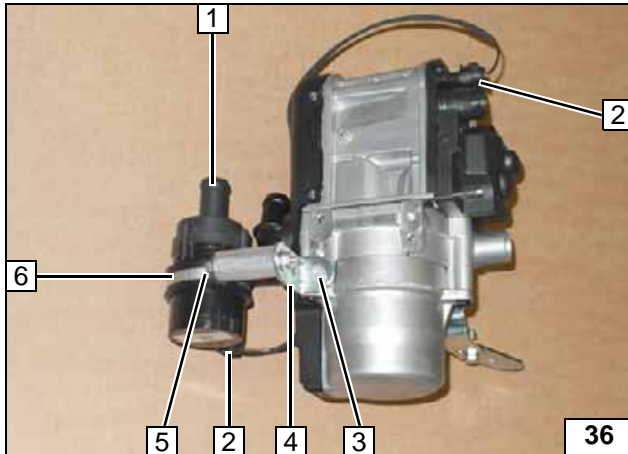
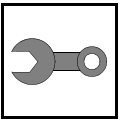

- 1 Circulating pump
- 2 Connector of circulating pump wiring harness
- 3 5x13 self-tapping bolt
- 4 Angle bracket
- 5 M6x60 bolt, 40 mm shim, flanged nut
- 6 48 mm dia. rubber-coated p-clamp

Installing circulating pump

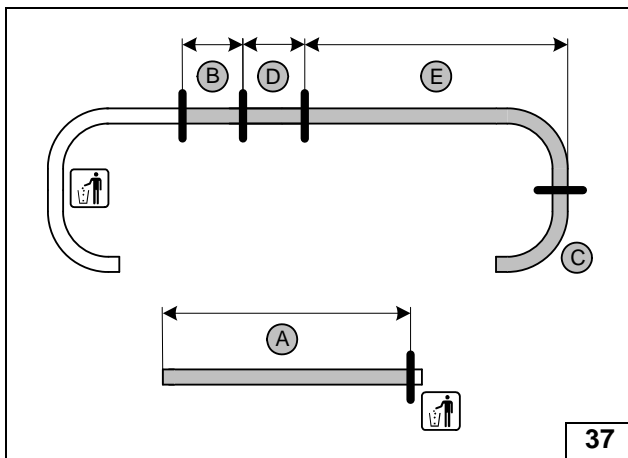

	Diesel	Petrol
A	1190	1260
B	140	140
C	90°	90°
D	160	160
E	1190	1190

Cutting hoses to length

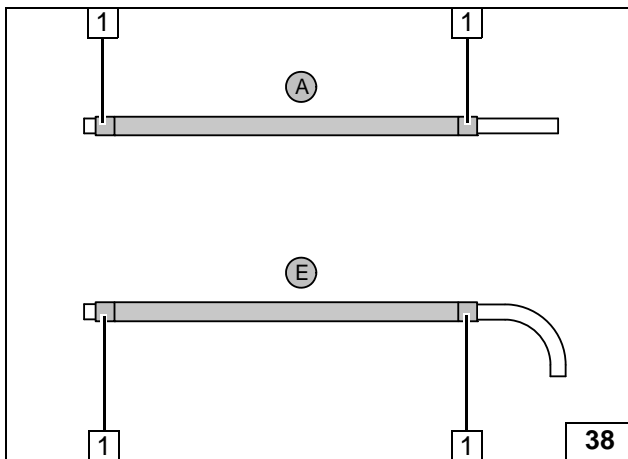

Push braided protection hoses onto hoses **A** and **E** . Cut heat shrink plastic tubing to size.



- 1 50 mm long heat shrink plastic tubing [4x]

Preparing hoses

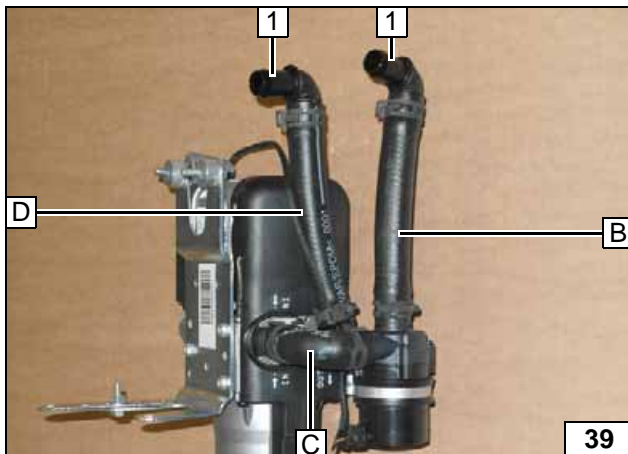

All spring clips 25mm dia.

- 1 18x18 mm, 90° connecting pipe [2x]



Premounting hoses

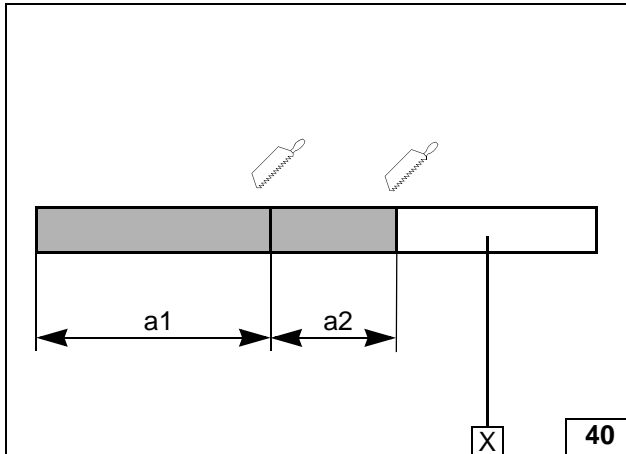
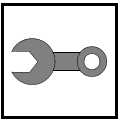

	Diesel	Petrol
a1	380	410
a2	170	220

X =

Preparing exhaust pipe

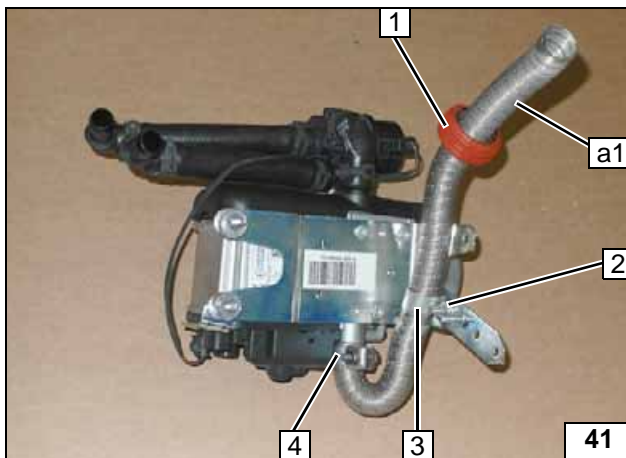

- 1 Spacer bracket
- 2 M6x20 bolt, flanged nut
- 3 P-clamp
- 4 Hose clamp

Premounting exhaust pipe

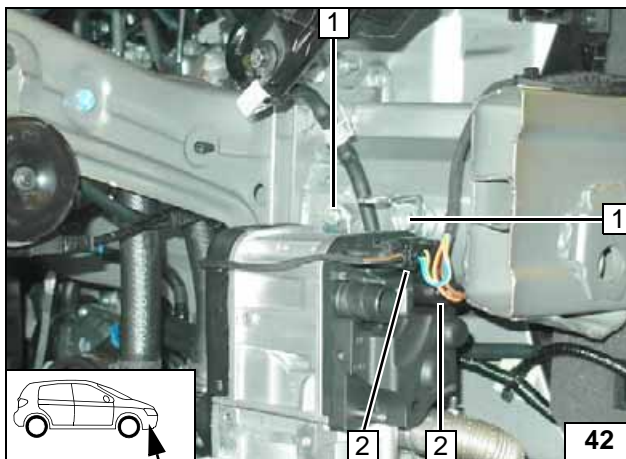

Installing Heater



Fasten heater and bracket to rivet nuts using bolts 1.

- 2 Heater wiring harness connector [2x]

Installing heater

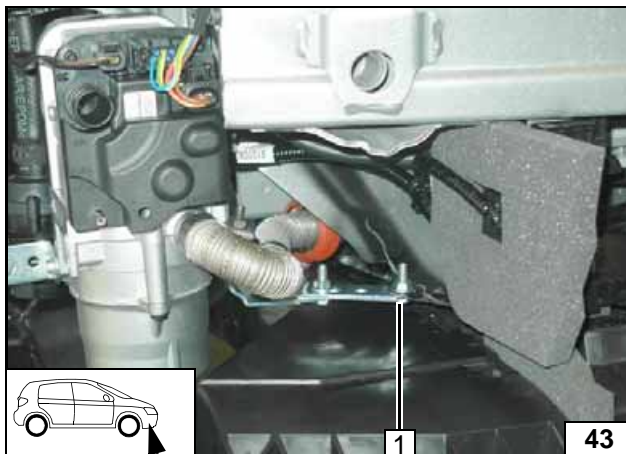

- 1 M6x20 bolt, original vehicle hole, flanged nut

Installing heater

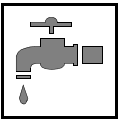

Coolant Circuit



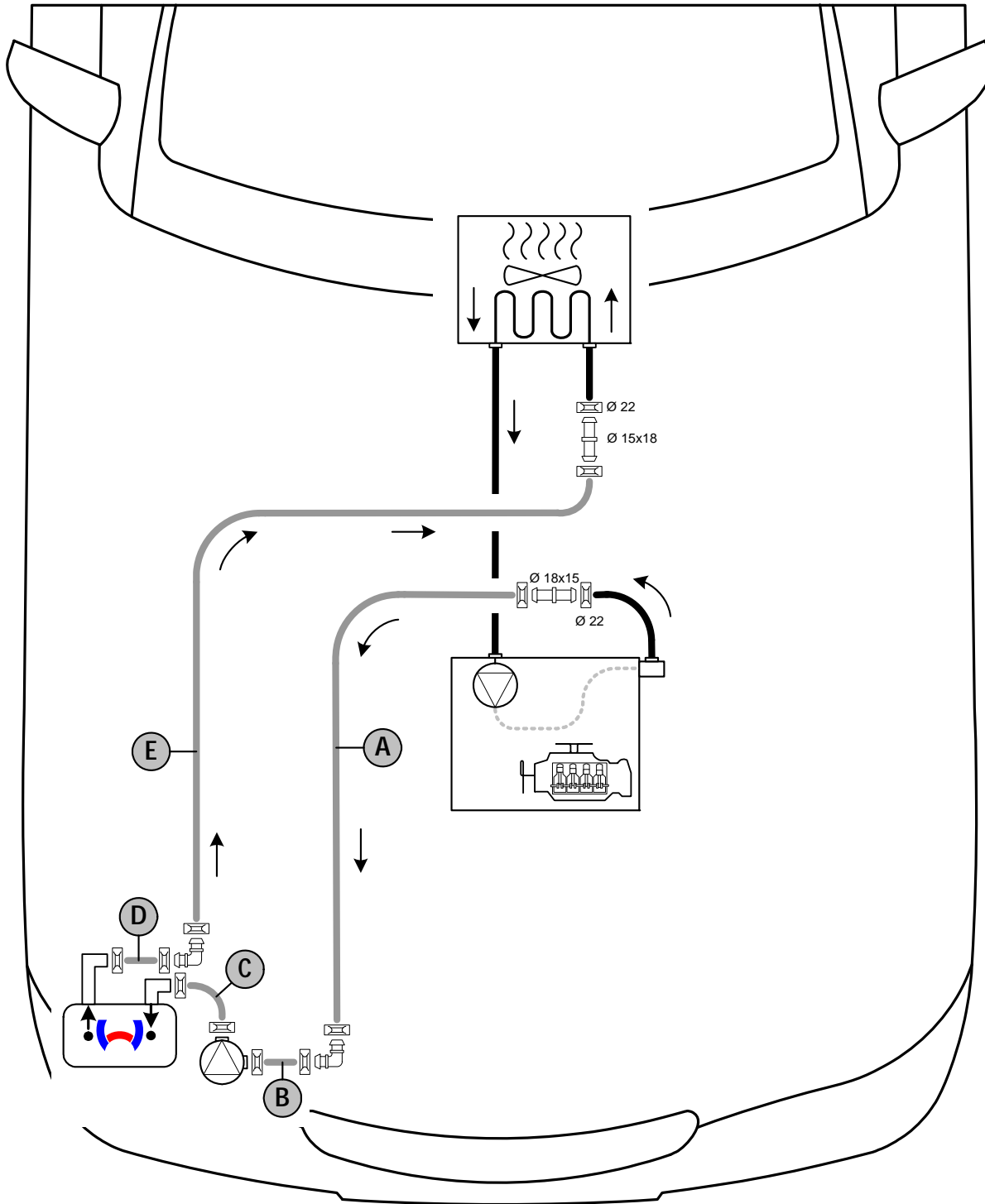

Any coolant running off should be collected in an appropriate container. Route hoses kink-free. Unless specified otherwise, always fasten using cable ties. Position clamps so that other hoses cannot be damaged. The heater must be filled with coolant when installing the hoses.

The connection should be modelled on an 'inline' circuit and based on the following diagram:



Hose routing diagram

All spring clips without a specific designation  = 25 mm dia.
 All connecting pipes  = 18x18 mm dia.



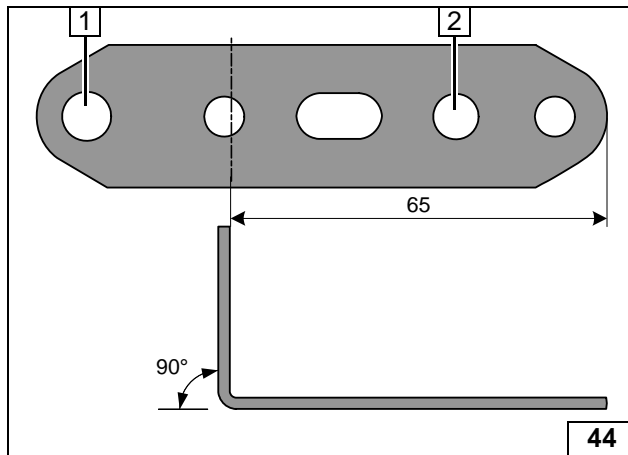

Coolant System Integration for Diesel Vehicles

- 1 Drill out hole to 8.5 mm dia.
- 2 Drill out hole to 8 mm dia.

Preparing perforated bracket 1

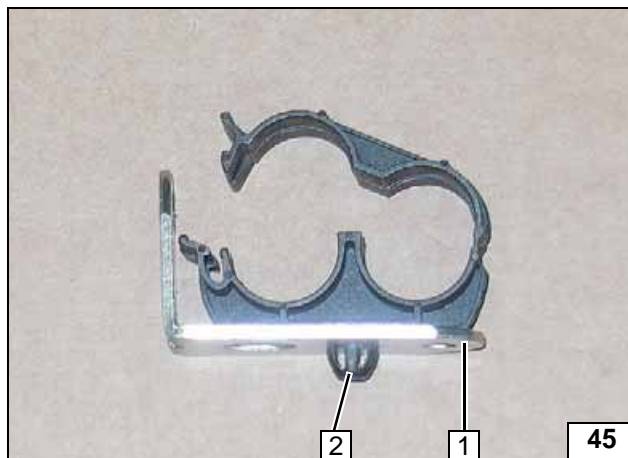

- 1 Perforated bracket 1
- 2 Hose bracket in 8mm dia. hole

Premounting hose bracket

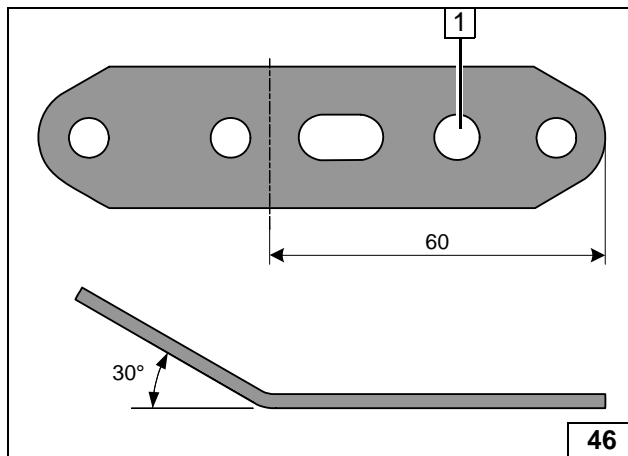

- 1 Drill out hole to 8 mm dia.

Preparing perforated bracket 2



- 1 Perforated bracket 2
- 2 Hose bracket in 8mm dia. hole

Premounting hose bracket

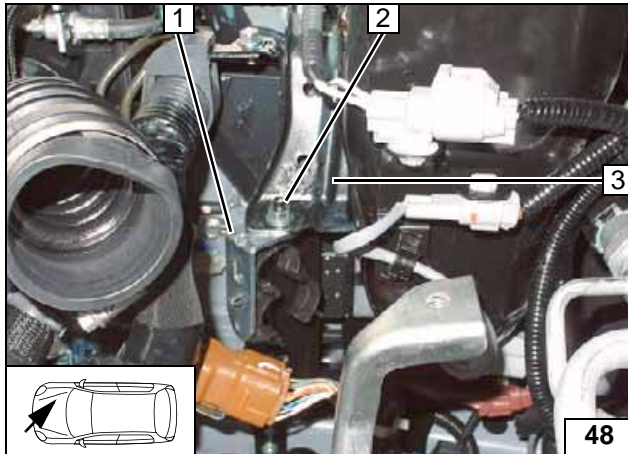
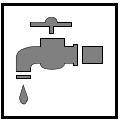

Remove original vehicle nut **2**, position perforated bracket **1** under cross member and fasten using nut **2**.



Installing perforated bracket 1

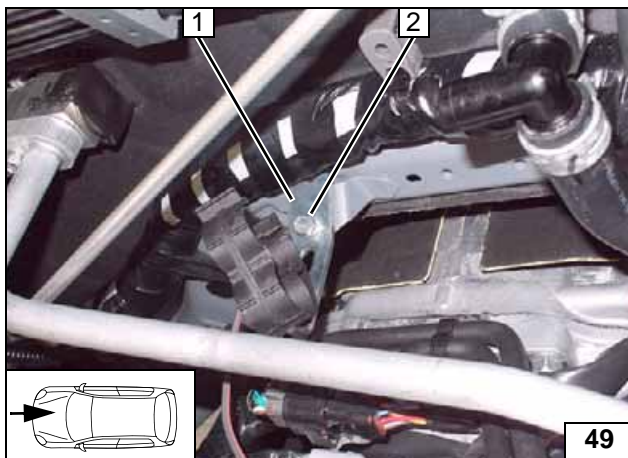

- 1 Perforated bracket 2
- 2 Original vehicle bolt

Installing perforated bracket 2

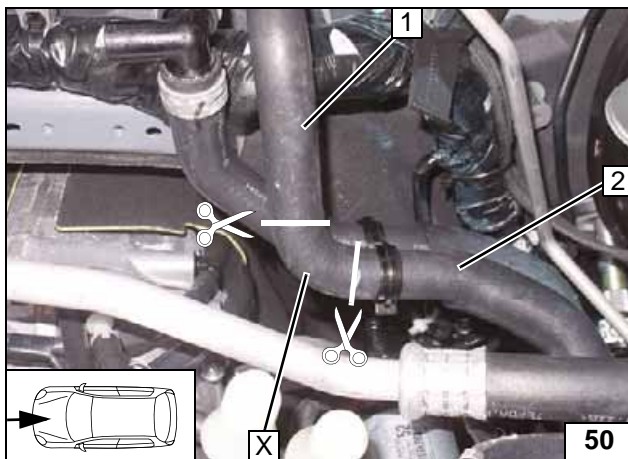

Cut hose of engine outlet / heat exchanger inlet **1** at the marking.

- 1 Heat exchanger inlet hose section
- 2 Engine outlet hose section

X =



Cutting point

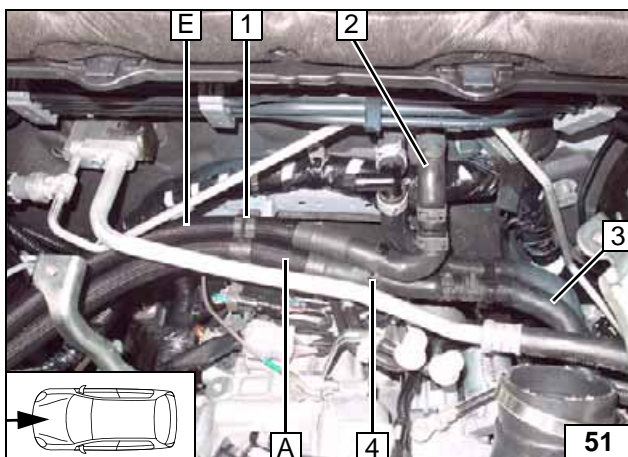

- 1 Close hose bracket
- 2 Heat exchanger inlet hose section
- 3 Engine outlet hose section
- 4 Hose bracket between hoses **A** and **E**

Connecting engine outlet / heat exchanger inlet

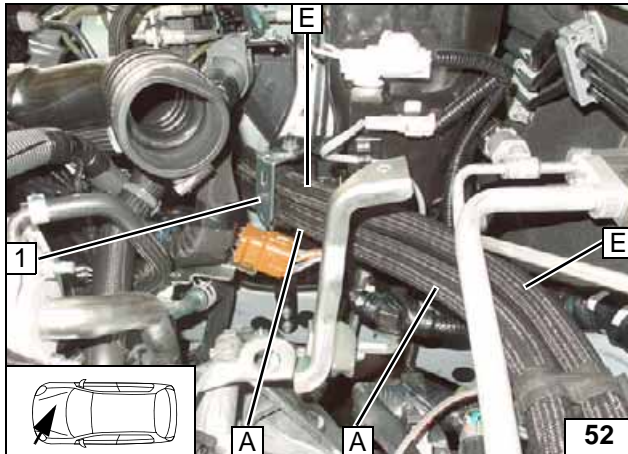
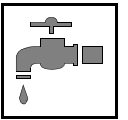

1 Close hose bracket

Routing in engine compartment

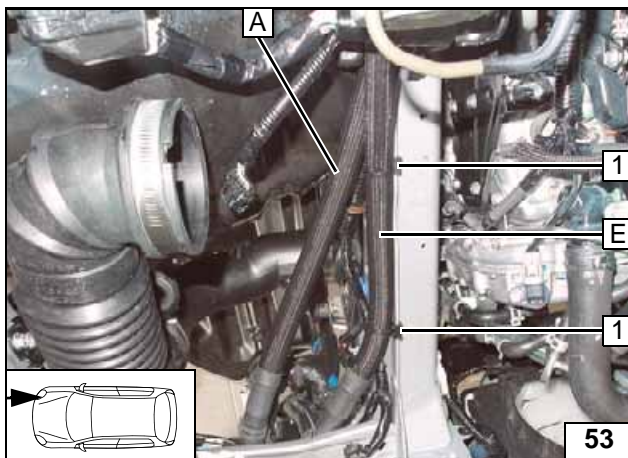

1 Clip-type cable tie [2x]

Routing in engine compartment

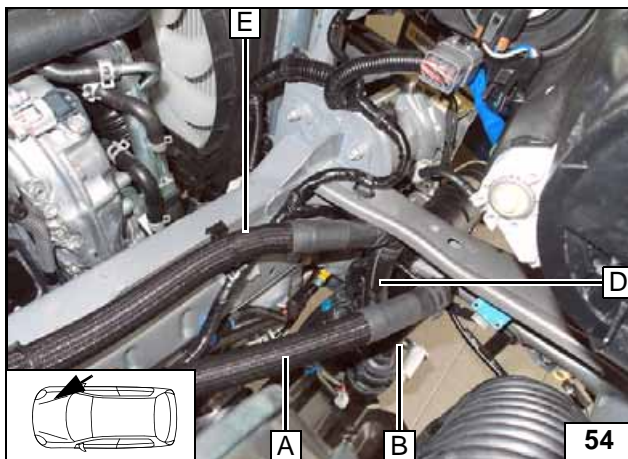

Connect-
ing heater

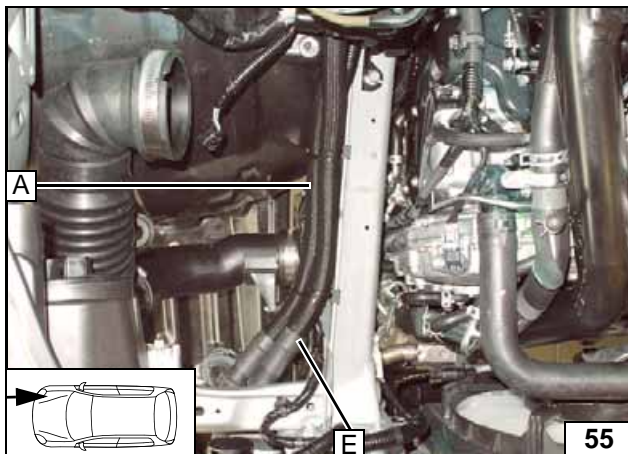

Fasten hose **A** to hose **E** using a cable tie and align.



Aligning hoses

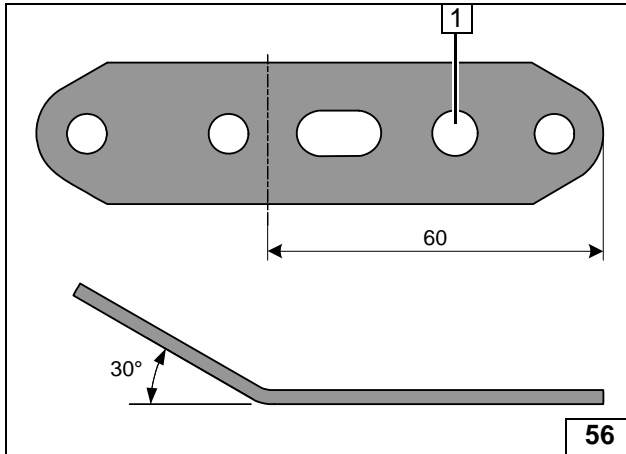
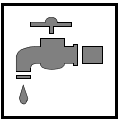

Coolant System Integration for Petrol Vehicles

- 1 Drill out hole to 8 mm dia.

Preparing perforated bracket



- 1 Hose bracket in 8mm dia. hole

Premounting hose bracket

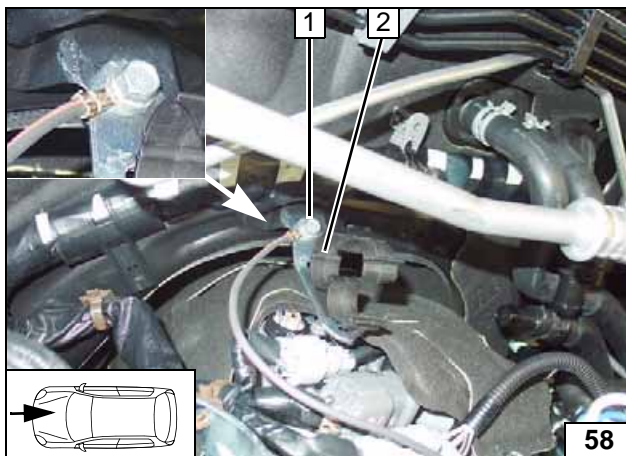

- 1 Original vehicle bolt
- 2 Perforated bracket with hose bracket

Installing perforated bracket

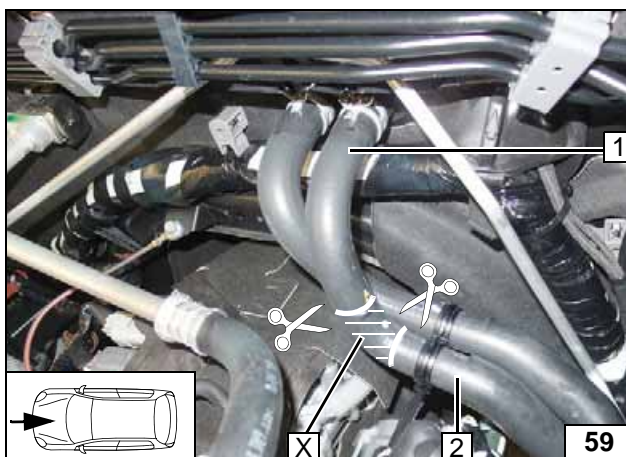

Cut hose of engine outlet / heat exchanger inlet 1 at the marking.

- 1 Heat exchanger inlet hose section
- 2 Engine outlet hose section

X =

Cutting point

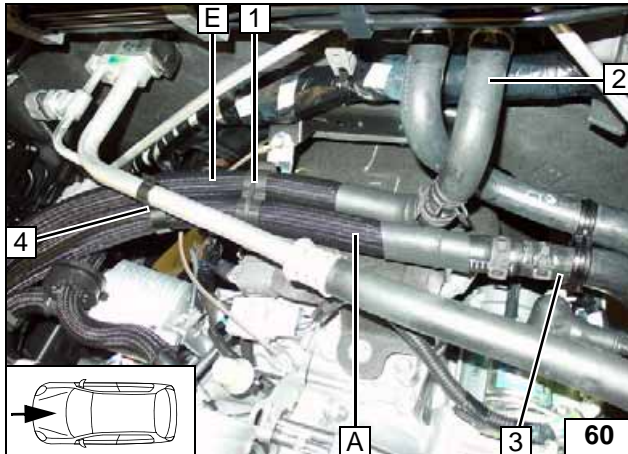

- 1 Close hose bracket
- 2 Heat exchanger inlet hose section
- 3 Engine outlet hose section
- 4 22-13 hose bracket

Connect-
ing engine
outlet / heat
exchanger
inlet

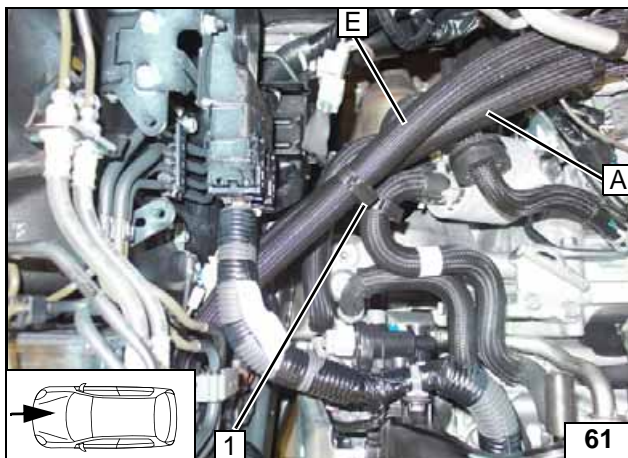

- 1 25-25 hose bracket

Routing in
engine
compart-
ment

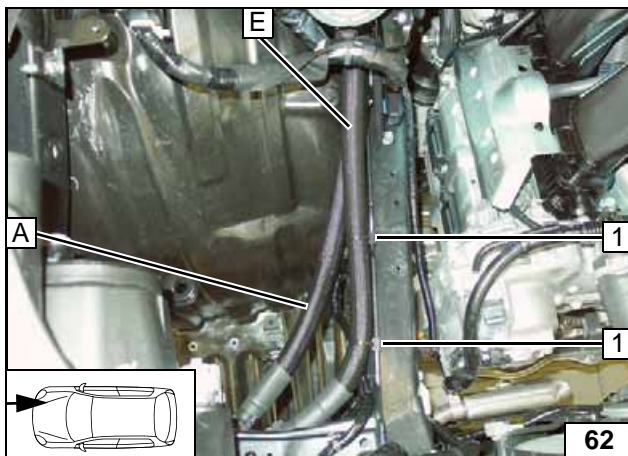

- 1 Cable tie with clip [2x]

Routing in
engine
compart-
ment

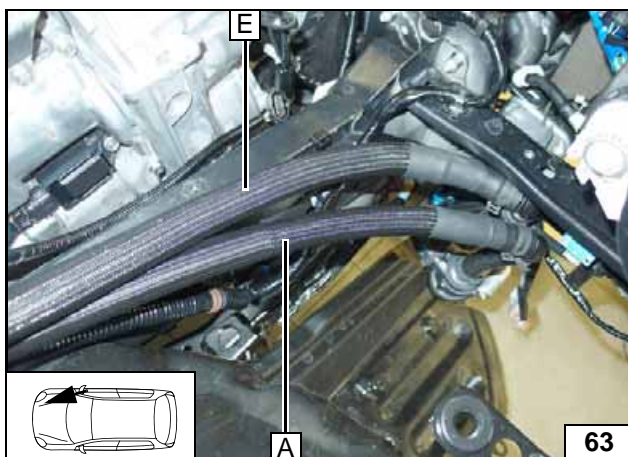

Connect-
ing heater

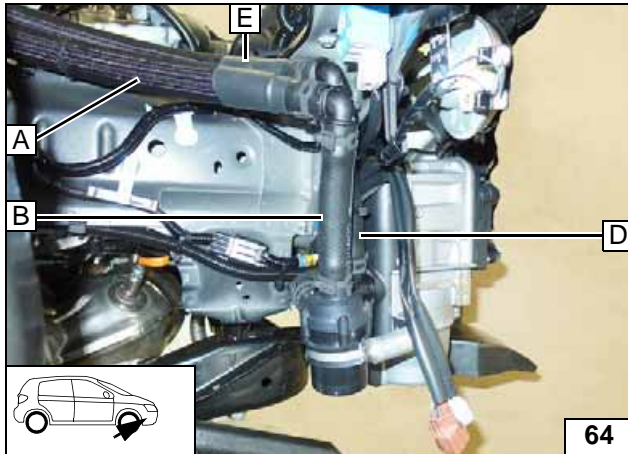
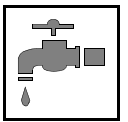

Connect-
ing heater

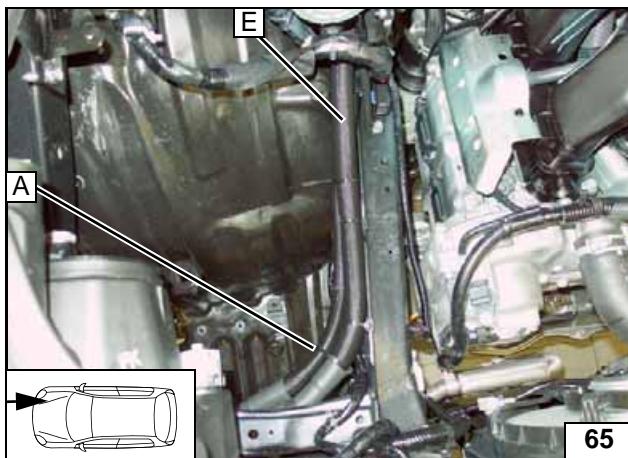

Fasten hose **A** to hose **E** using a cable tie and align.



Aligning
hoses

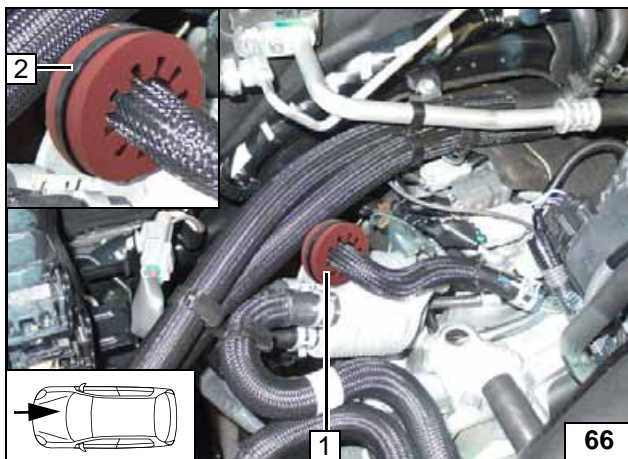

Cut open red (rt) rubber isolator **1**, position onto hose and secure using cable tie **2**.



Installing red
rubber isola-
tor

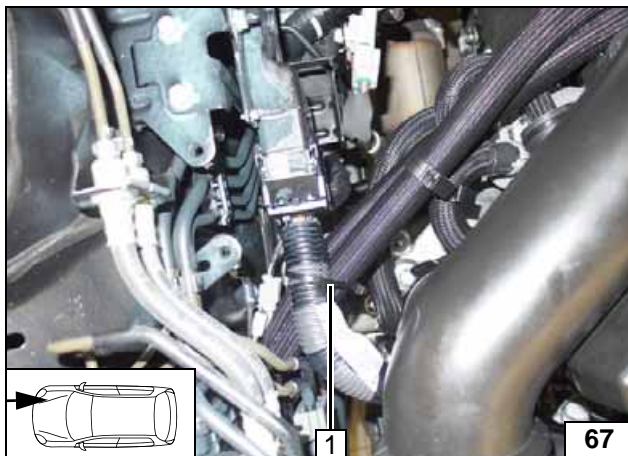

1 Cable tie

Attaching
hoses

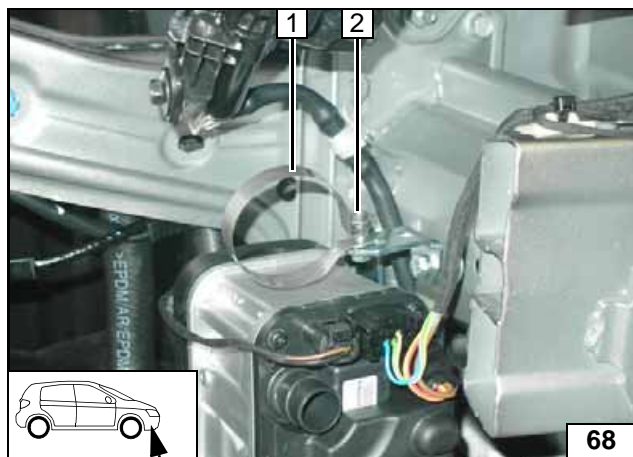
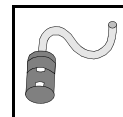

Combustion Air

- 1 51 mm dia. clamp
- 2 M5x16 bolt, flanged nut premounted loosely

Premounting clamp

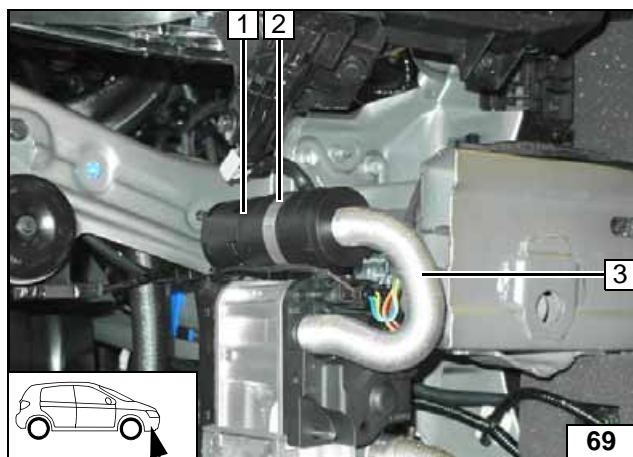

- 1 Silencer
- 2 Tighten 51mm dia. clamp
- 3 Combustion air pipe (210 mm long)



Installing silencer

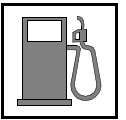

Fuel



Open the vehicle's fuel tank cap, ventilate the tank and then re-close the tank lock.

Catch any fuel running off in an appropriate container.



Route fuel line and metering pump wiring harness so that they are protected against stone impact. Unless specified otherwise, always fasten using cable ties.

Provide rub protection for fuel line and wiring harness in areas where there are sharp edges.

The fuel line and wiring harness are routed to the metering pump as shown in the wiring harness routing diagram.

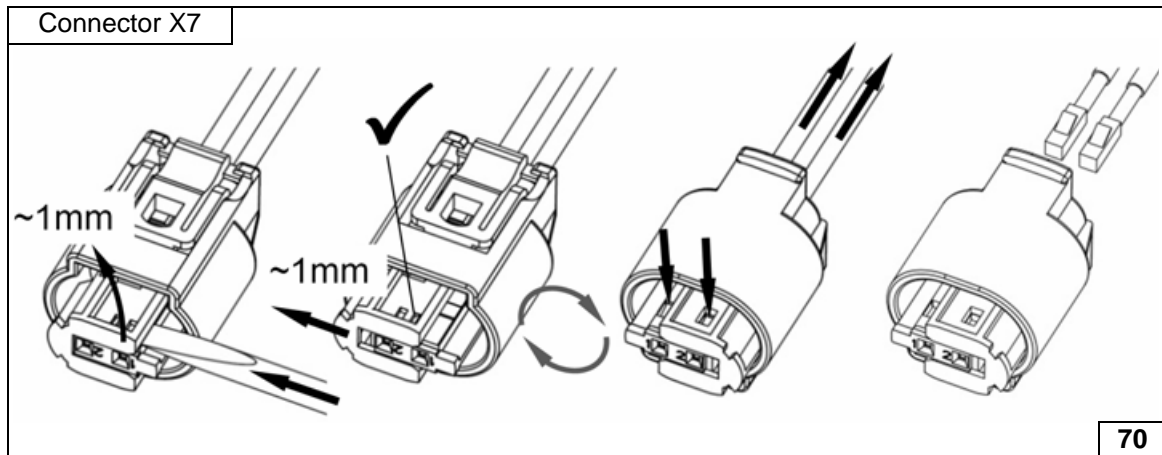

Dismantling metering pump connector

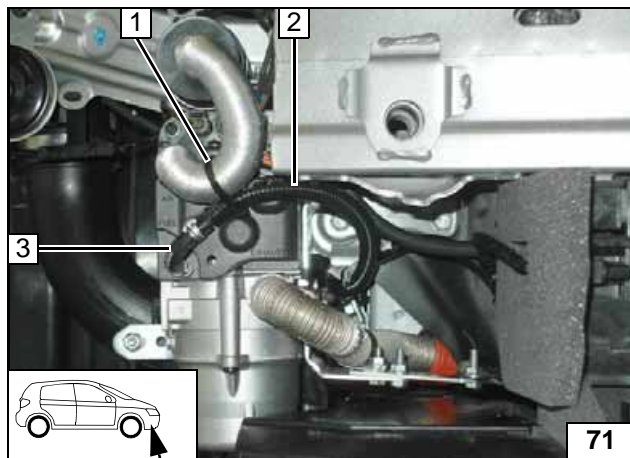

- 1 Cable tie around corrugated tube and combustion air pipe
- 2 Fuel line and wiring harness of metering pump in corrugated tube
- 3 90° moulded hose, 10 mm dia. clamp [2x]

Connecting heater

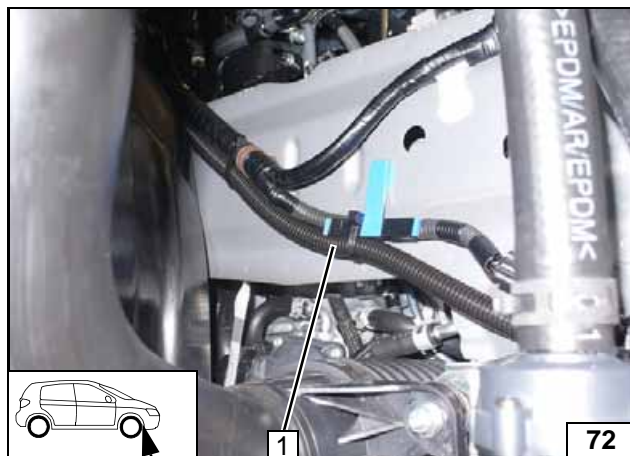

Route corrugated tube 1 with fuel line and wiring harness of metering pump along original vehicle lines to installation location of metering pump and secure using cable ties.



Routing lines



1 Corrugated tube

Routing lines

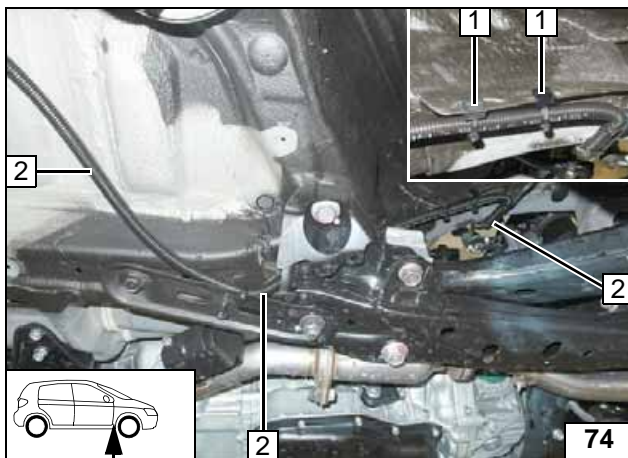

1 Clip-type cable tie [2x]
2 Corrugated tube

Routing lines

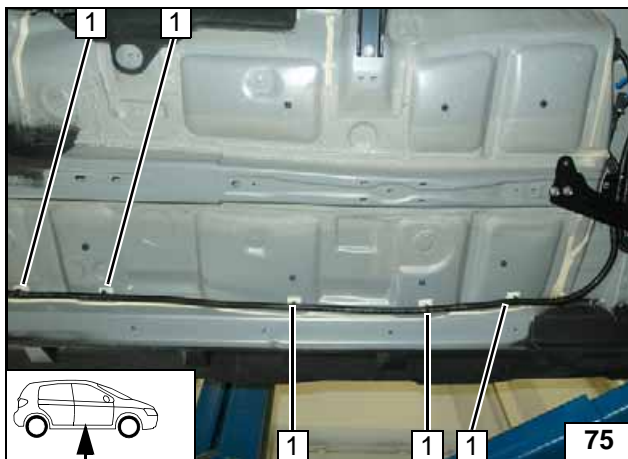

Degrease bonding surfaces.
Stick adhesive bases 1 [5x] onto the underbody. Fasten corrugated tube using cable ties.



Routing lines

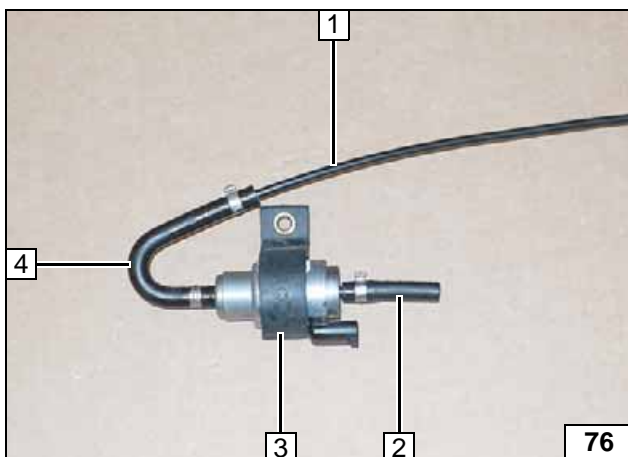

1 1000mm long fuel line
2 Hose section, 10 mm dia. clamp
3 Metering pump mount
4 180° moulded hose, 10 mm dia. clamp [2x]

Premounting metering pump

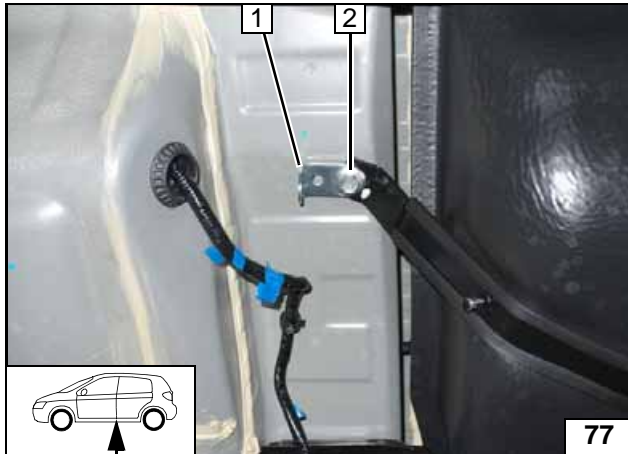

- 1 Angle bracket
- 2 Original vehicle bolt

Installing angle bracket

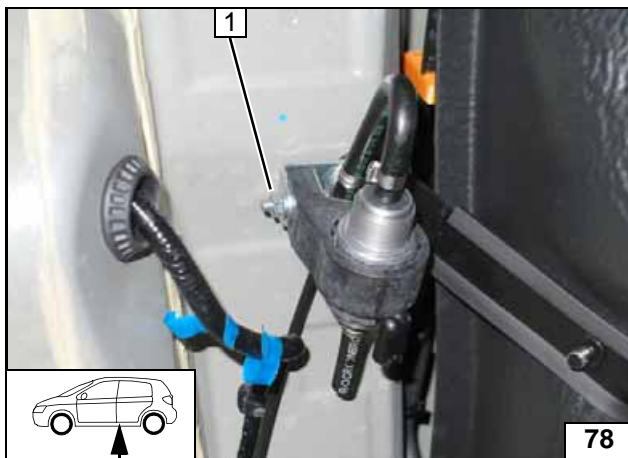

- 1 M6x25 bolt, support angle bracket, flanged nut



Installing metering pump

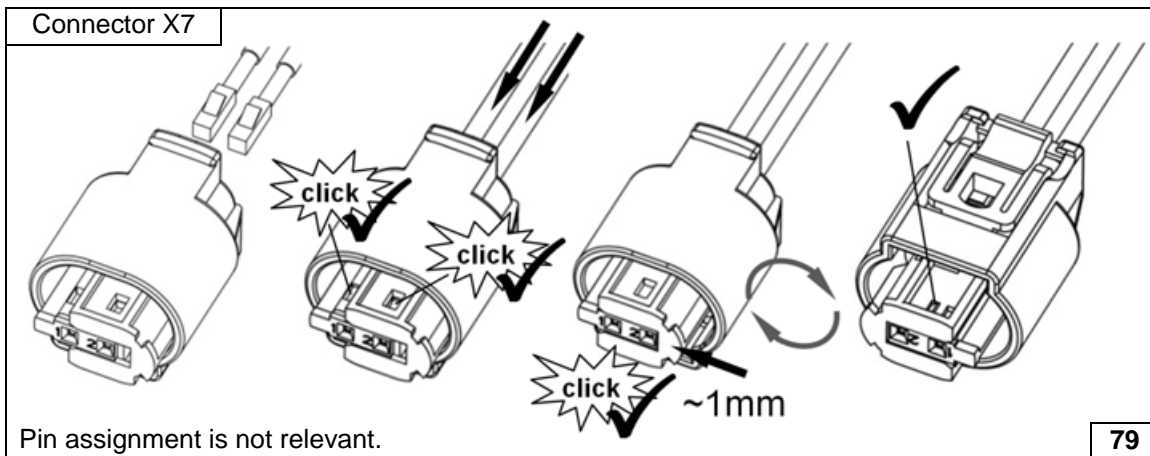

Completing metering pump connector

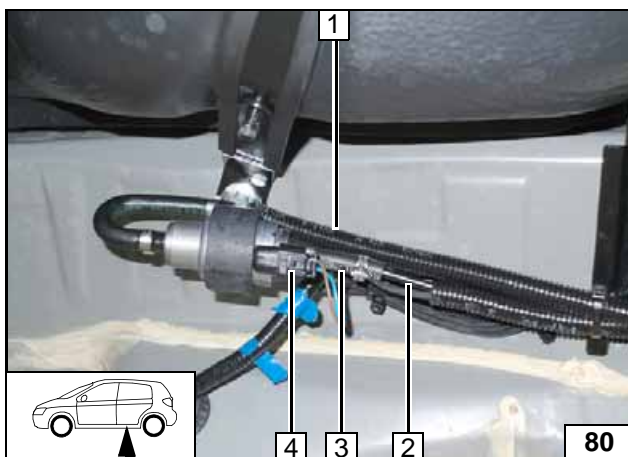

Ensure sufficient distance from adjacent components; correct if necessary. Pull premounted fuel line in corrugated tube 1 and route to the fuel tank sending unit.

- 2 Fuel line
- 3 Hose section, 10 mm dia. clamp [2x]
- 4 Metering pump wiring harness, connector X7 mounted



Connecting metering pump

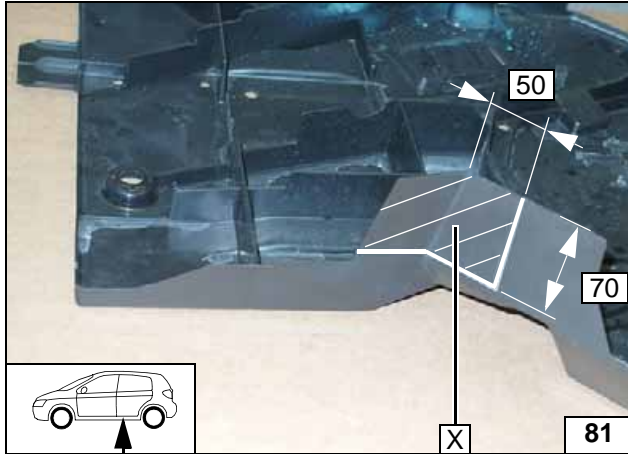

X =

Cutting out underbody trim of tank



Installing underbody trim of tank

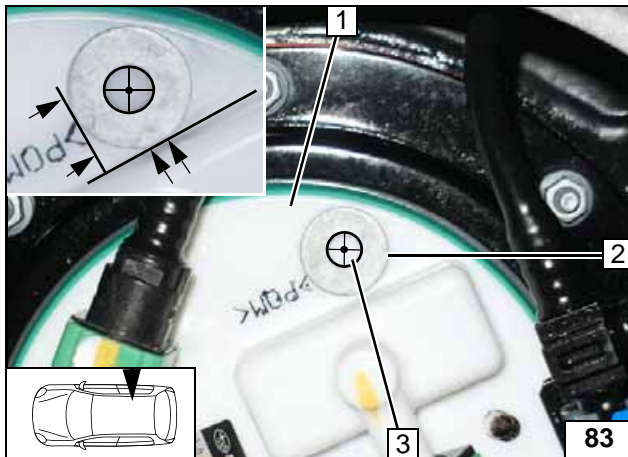

FuelFix Installation for Diesel Vehicles

Work steps F1 and F2.

- 1 Fuel tank sending unit
- 2 Position washer with outer dia. $d_a = 17.8\text{mm}$ as shown, will be used as a template
- 3 Hole pattern



Copying hole pattern

Work step F3.

- 1 Hole made with provided drill

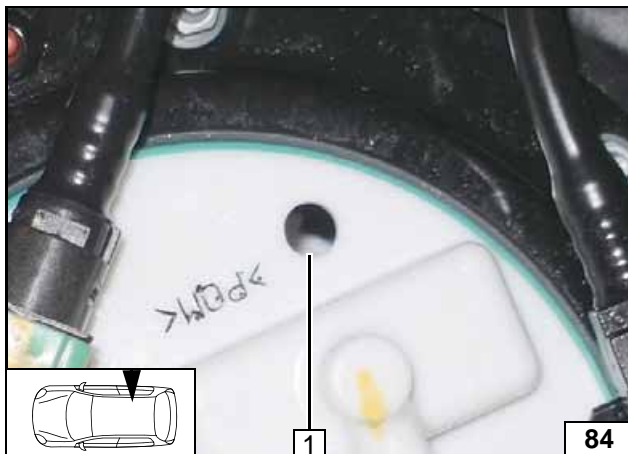

Hole for FuelFix

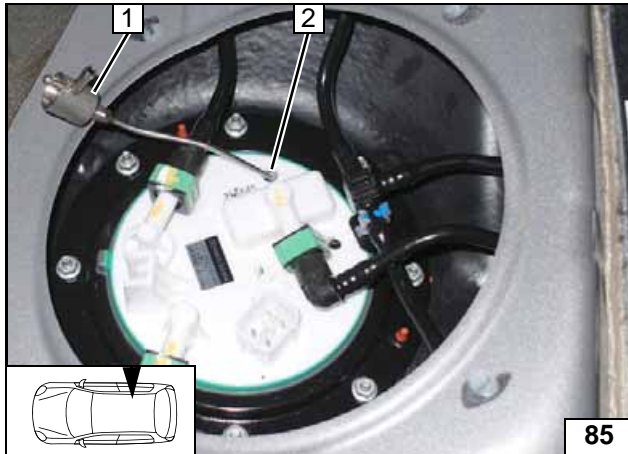

85

Work steps F4 and F5.

Bend FuelFix 1 according to template and cut to length. Insert into hole 2.



Inserting FuelFix

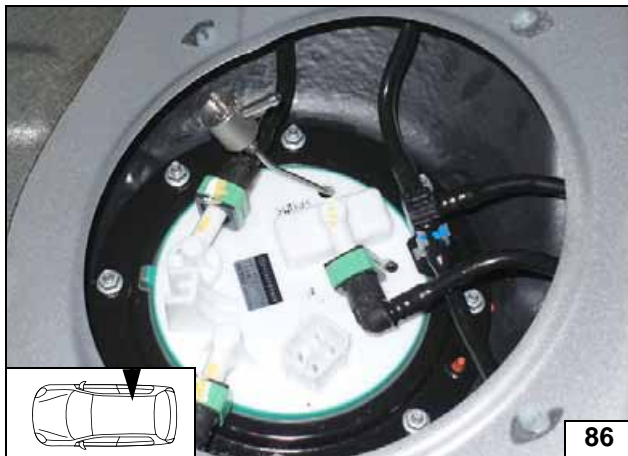

86

Inserting FuelFix

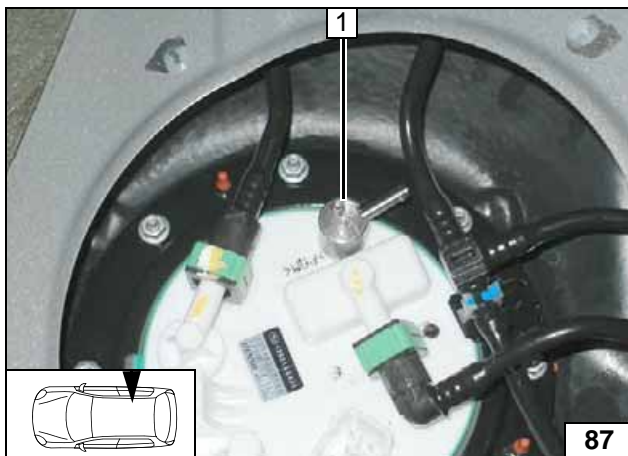

87

Work steps F5.3 and F5.4.

Align FuelFix 1 as shown.



Aligning FuelFix

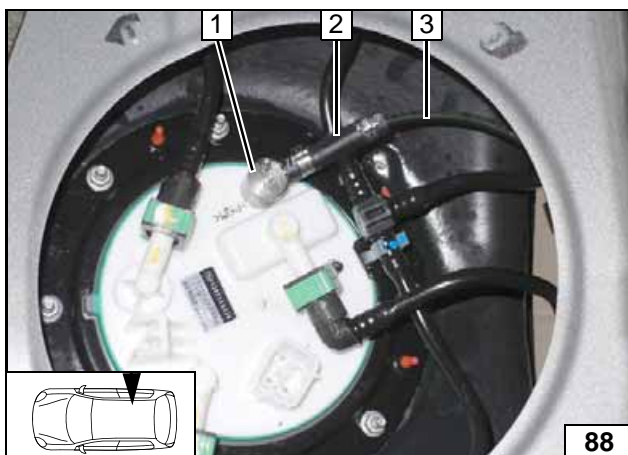

88

Work step F6.

- 1 FuelFix
- 2 Hose section, 10 mm dia. clamp [2x]
- 3 Cut fuel line to length and connect

**Connect-
ing fuel line**

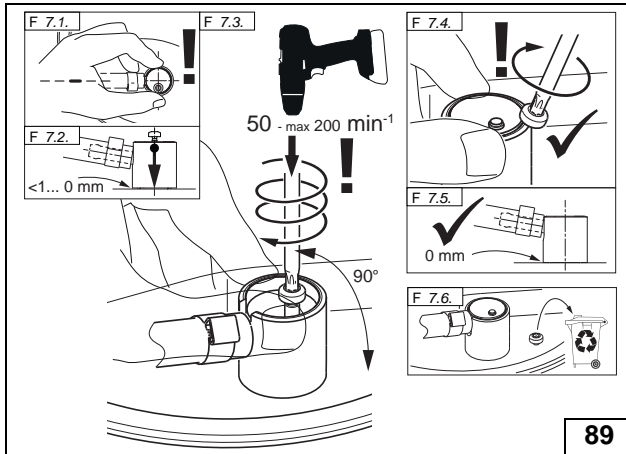

Work step F7.



Mounting FuelFix

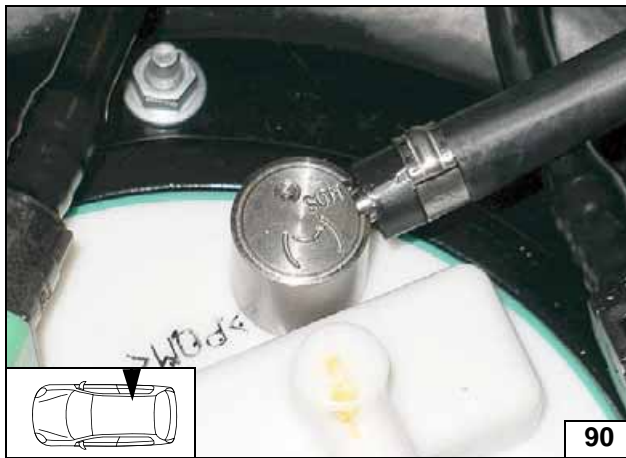

Work step F8.

Ensuring firm seating of FuelFix

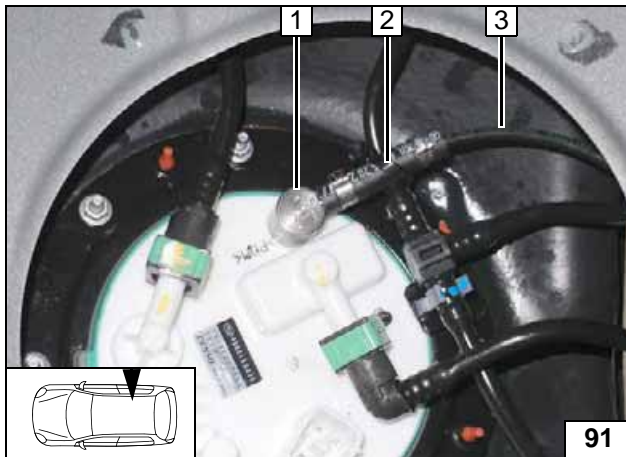

Work step F8.

- 1 FuelFix mounted
- 2 Cable tie as tension relief
- 3 Fuel line of FuelFix

Securing fuel line

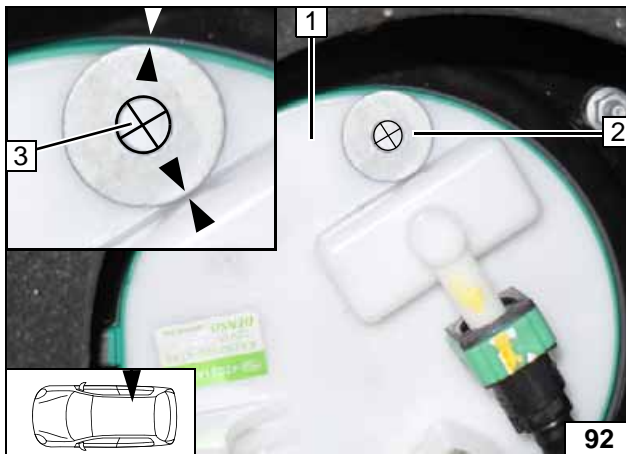

FuelFix Installation for Petrol Vehicles

Work steps F1 and F2.

- 1 Fuel tank sending unit
- 2 Position washer with outer dia. $d_a = 21.8 \text{ mm}$ as template
- 3 Hole pattern



Copying hole pattern

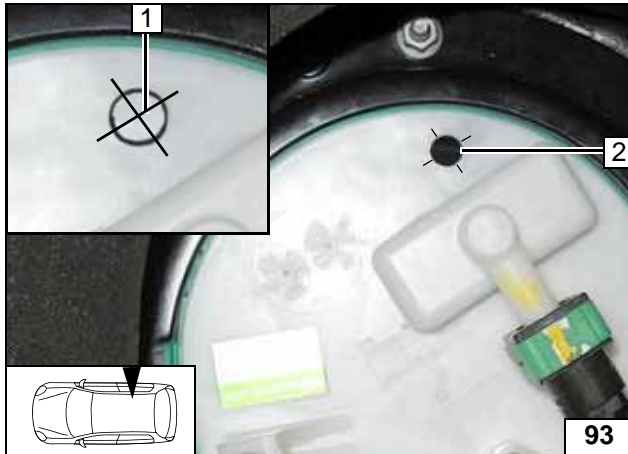

Work step F3.

- 1 Hole pattern
- 2 Hole made with provided drill

Hole for FuelFix

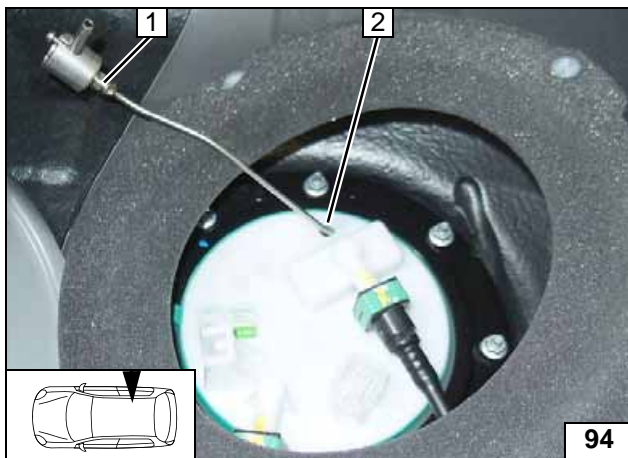

Work steps F4 and F5.

Bend FuelFix 1 according to template and cut to length. Insert into hole 2.



Inserting FuelFix

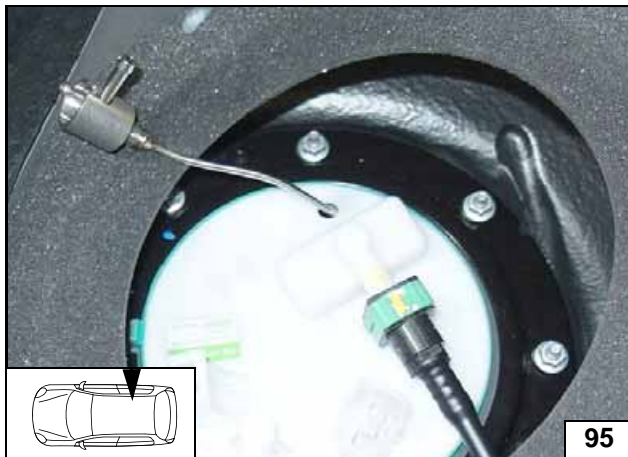

Inserting FuelFix

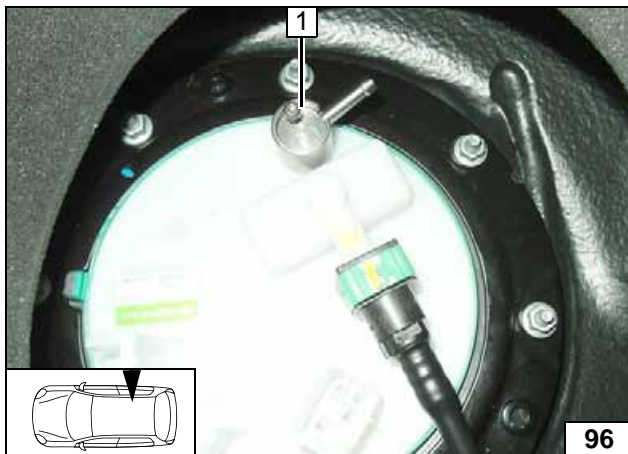

Work steps F5.3 and F5.4.

Align FuelFix 1 as shown.



Aligning FuelFix

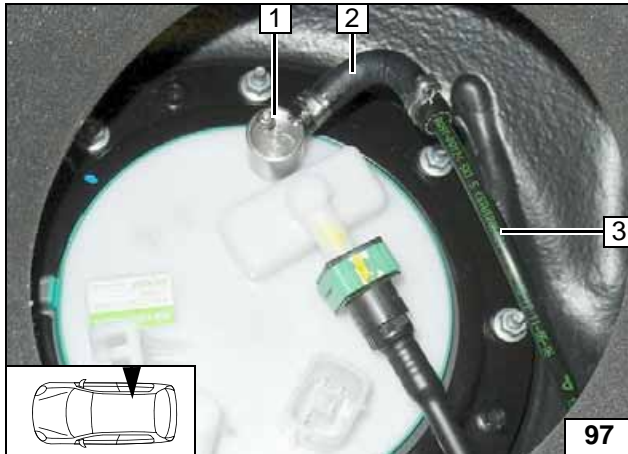

Work step F6.

- 1 FuelFix
- 2 Hose section, 10 mm dia. clamp [2x]
- 3 Cut fuel line to length and connect

Connect-
ing fuel line

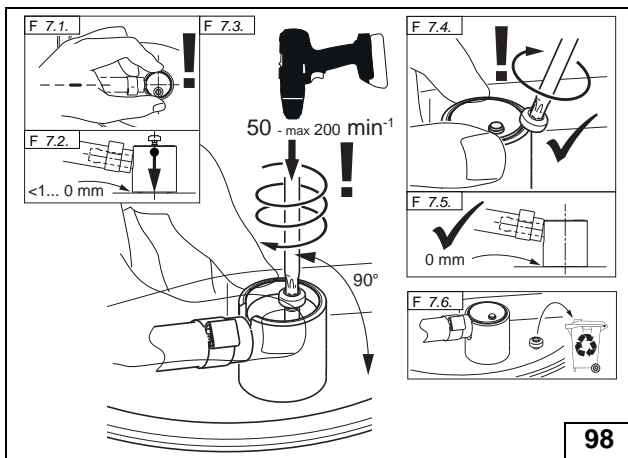

Work step F7.



Mounting
FuelFix



Work step F8.

Ensuring
firm seating
of FuelFix

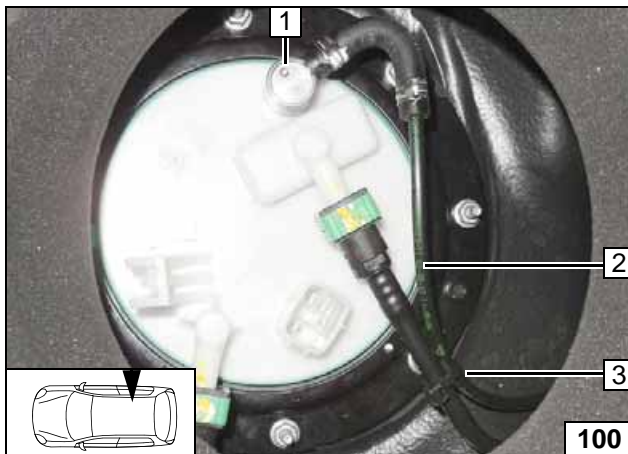

Work step F8.

- 1 FuelFix mounted
- 2 Fuel line of FuelFix
- 3 Cable tie as tension relief

Securing
fuel line

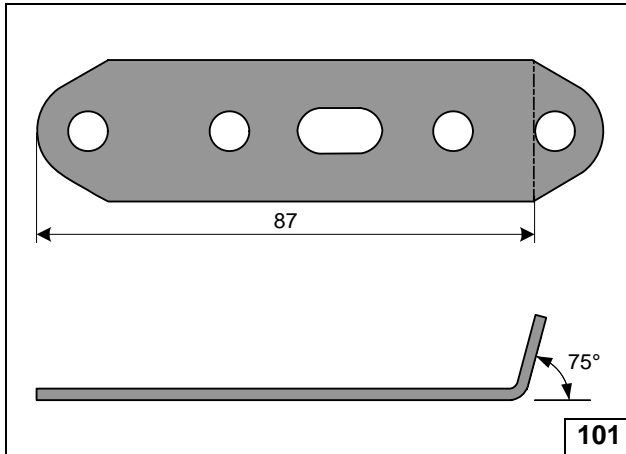
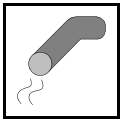

Exhaust Gas



Preparing perforated bracket

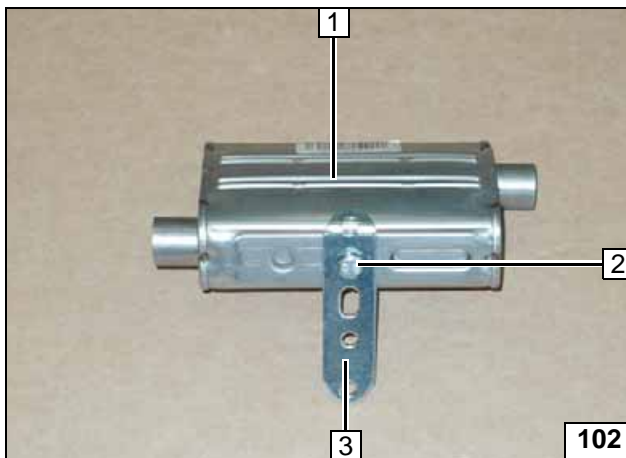

- 1 Silencer
- 2 M6x16 bolt, spring lockwasher
- 3 Perforated bracket

Premounting silencer

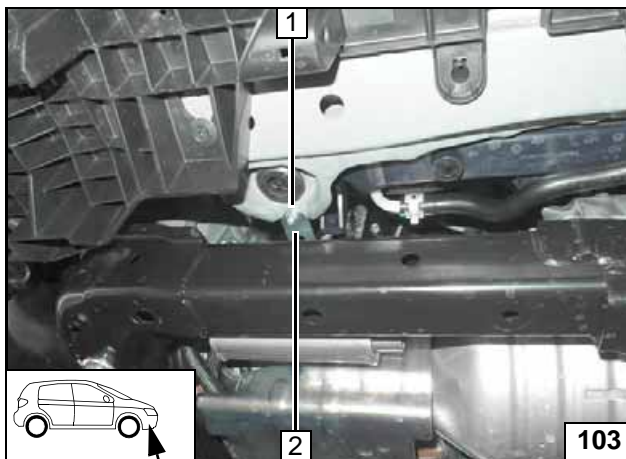

Diesel

- 1 Original vehicle stud bolt (if present), flanged nut
Optional: M6x20 bolt, flanged nut
- 2 Perforated bracket



Installing silencer

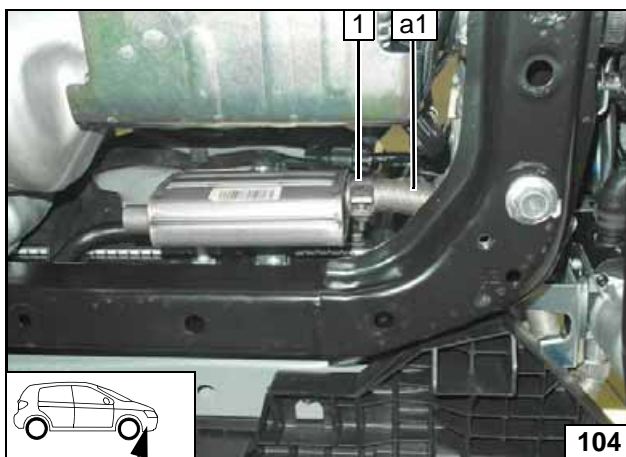

- 1 Hose clamp

Installing exhaust pipe a1

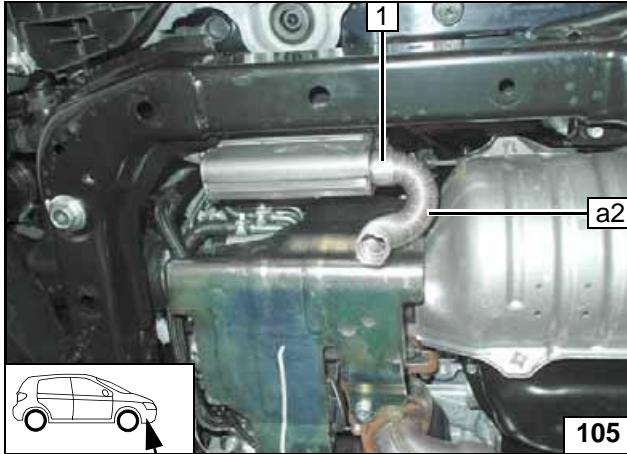
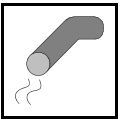

Ensure sufficient distance from adjacent components; correct if necessary.



1 Hose clamp

Installing exhaust pipe a2

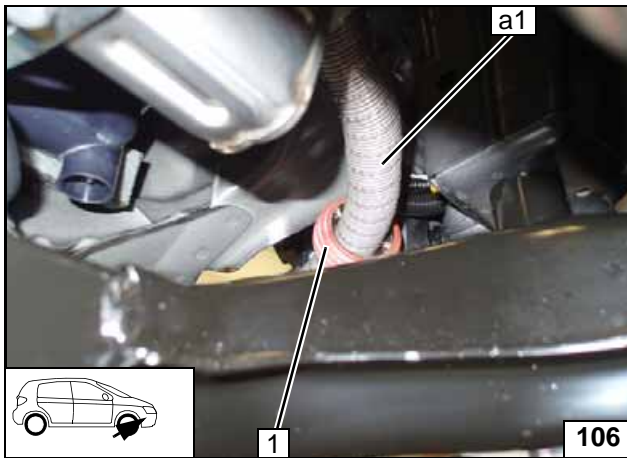

1 Spacer bracket

Positioning spacer bracket onto exhaust pipe a1

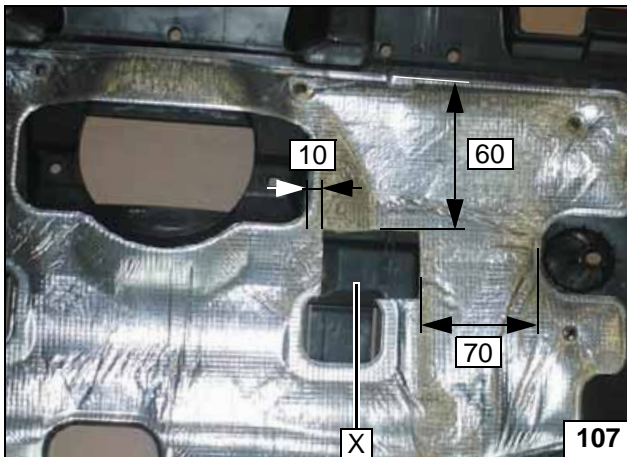

Cut out insulation as shown.



X =

Cutting out insulation of under-ride protection

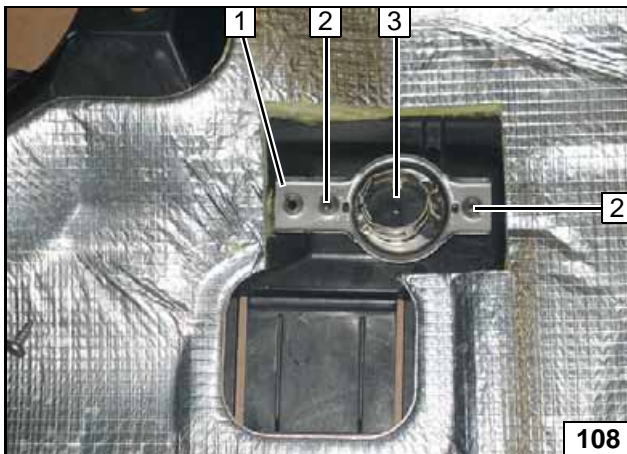

Position exhaust end fastener 1 as per work step 3 of the installation instructions and copy hole pattern 2 [2x].



3 Copy central hole pattern

Copying hole pattern

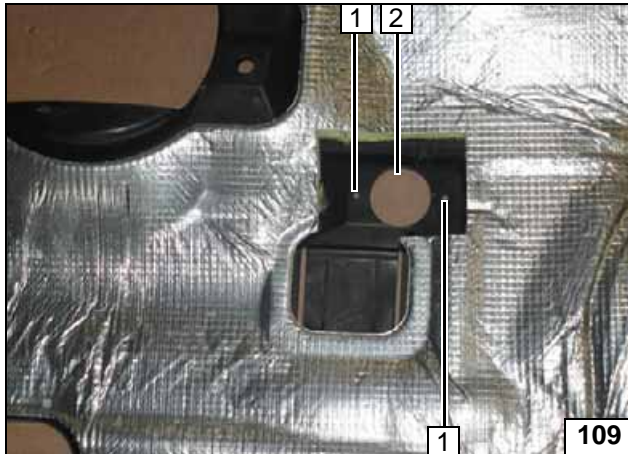
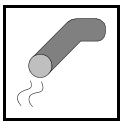

Hole 2 as per work step 1 of the installation instructions.
Hole 1 [2x] as per work step 4 of the installation instructions.

Holes in under-
derride pro-
tection

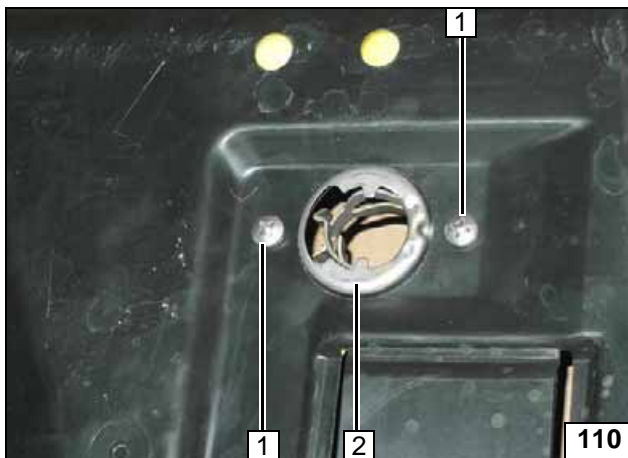

- 1 5x13 self-tapping screw [2x] as per work step 5 of the installation instructions
- 2 Exhaust end fastener

Installing ex-
haust end
fastener

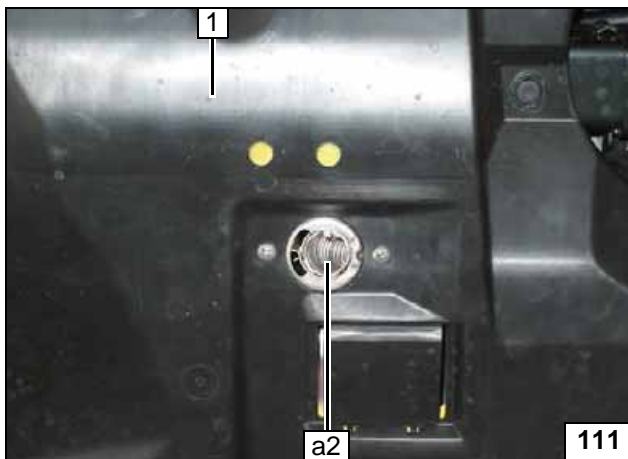

Install bumper.
Install underderride protection 1.
Install exhaust pipe a2 as per work steps 6 - 8 of the installation instructions.

Installing
exhaust
pipe a2

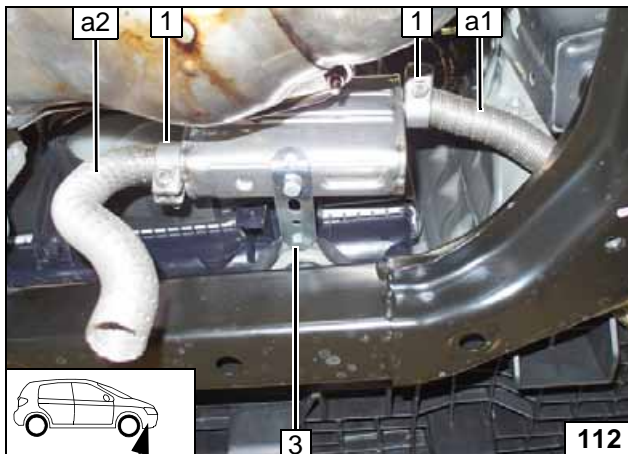

Petrol

- 1 Hose clamp
- 2 Original vehicle stud bolt (if present), flanged nut
Optional: M6x20 bolt, flanged nut
- 3 Perforated bracket

Installing
silencer
and ex-
haust pipe

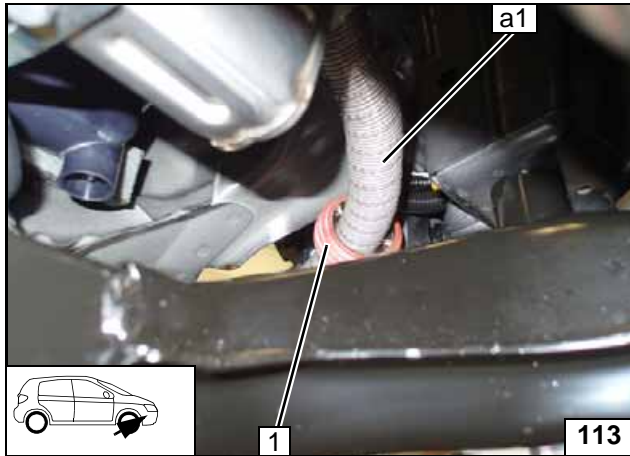
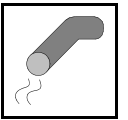

1 Spacer bracket

Positioning spacer bracket onto exhaust pipe a1



Ensure sufficient distance from adjacent components; correct if necessary.



Checking distance



X =

Cutting out insulation of under-ride protection

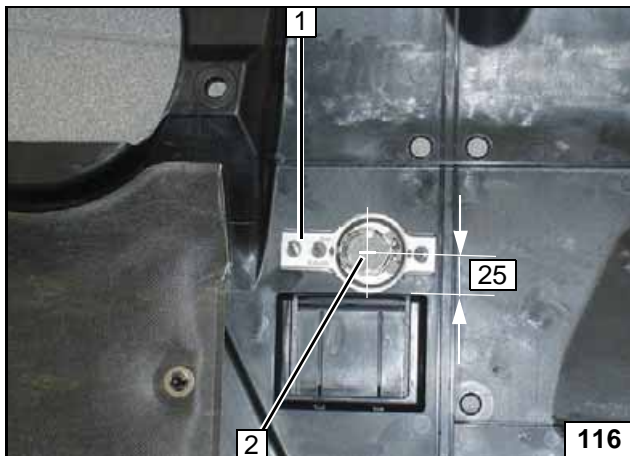

- 1 Position exhaust end fastener
- 2 Position hole as per work step 1 of the installation instructions



Position and hole pattern for exhaust end fastener

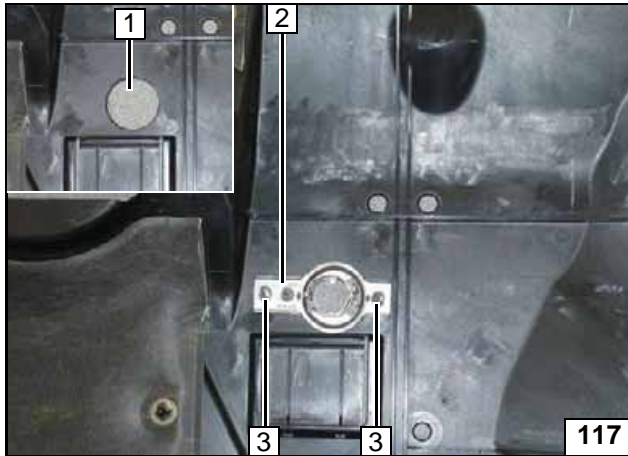
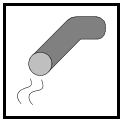

Hole 1 as per work step 1 of the installation instructions.
Position exhaust end fastener 2 as per work step 3 of the installation instructions and copy hole pattern 3 [2x].



Hole pattern for exhaust end fastener

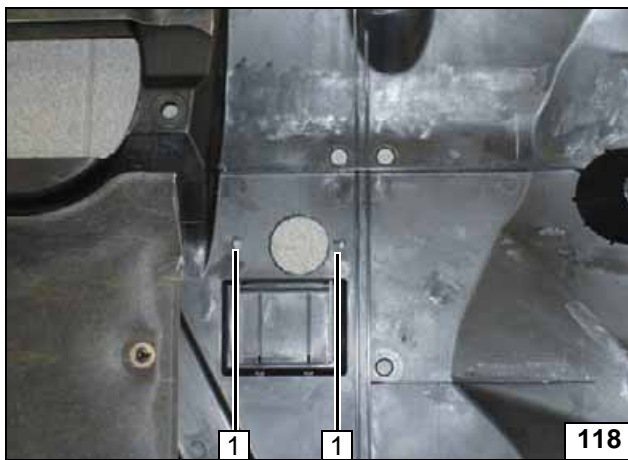

Hole 1 [2x] as per work step 4 of the installation instructions.



Holes in underdrive protection

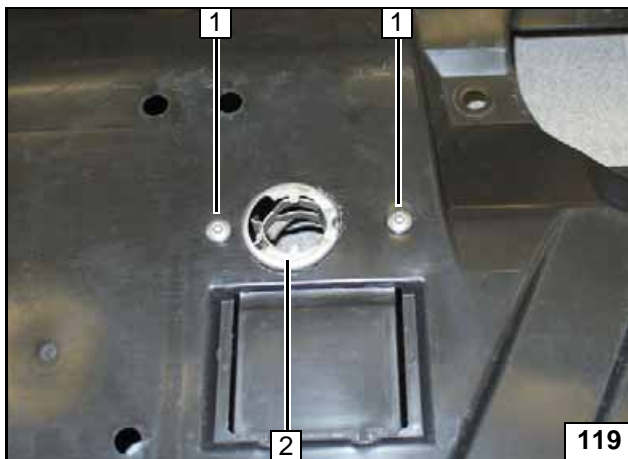

- 1 5x13 self-tapping screw [2x] as per work step 5 of the installation instructions
- 2 Exhaust end fastener



Installing exhaust end fastener

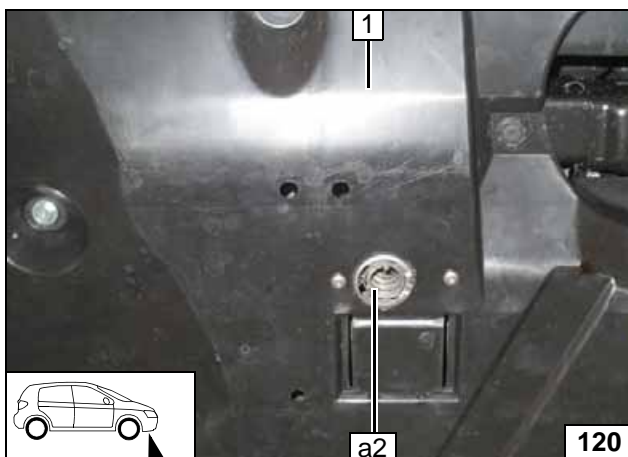

Install bumper. Install underdrive protection 1. Install exhaust pipe a2 as per work steps 6 - 8 of the installation instructions.



Installing exhaust pipe a2



Final Work



Reassemble the components in reverse order. Check all hoses, clamps and all electrical connections for firm seating. Insulate and tie back loose lines. Only use manufacturer-approved coolant. Spray the heater components with anti-corrosion wax (Tectyl 100K).

- **Connect the battery.**
- **Fill and bleed the coolant circuit according to the vehicle manufacturer's specifications.**
- **Program MultiControl CAR, teach Telearstart transmitter.**
- **Make settings on A/C control panel according to the 'Operating Instructions for Automatic A/C'.**
- **Place the 'Switch off parking heater before refuelling' caution label near the filler neck.**
- **For initial startup and function check, please see installation instructions.**



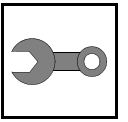

Template for Bracket

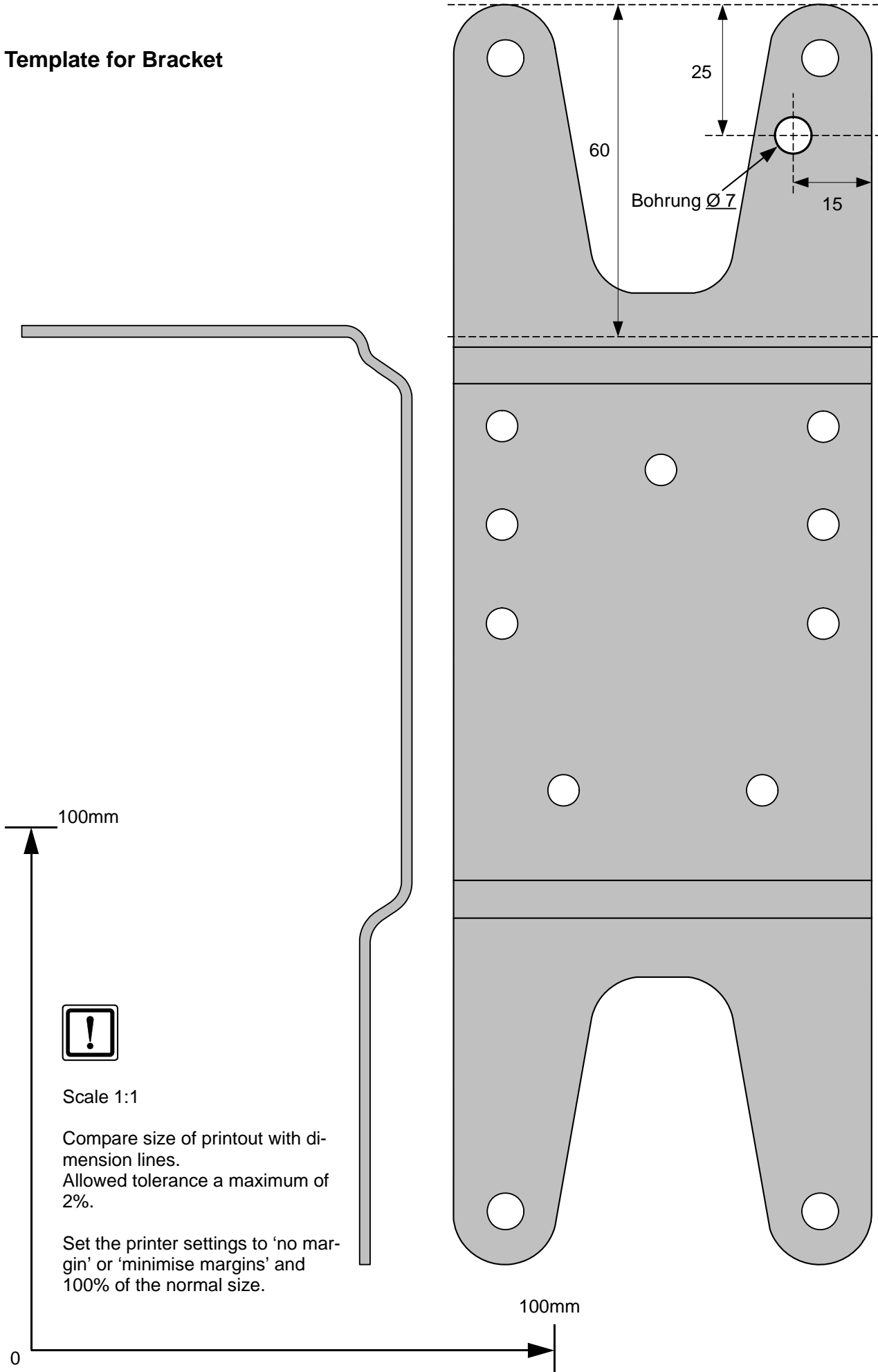

Scale 1:1

Compare size of printout with dimension lines.
Allowed tolerance a maximum of 2%.

Set the printer settings to 'no margin' or 'minimise margins' and 100% of the normal size.



FuelFix Template

Top view

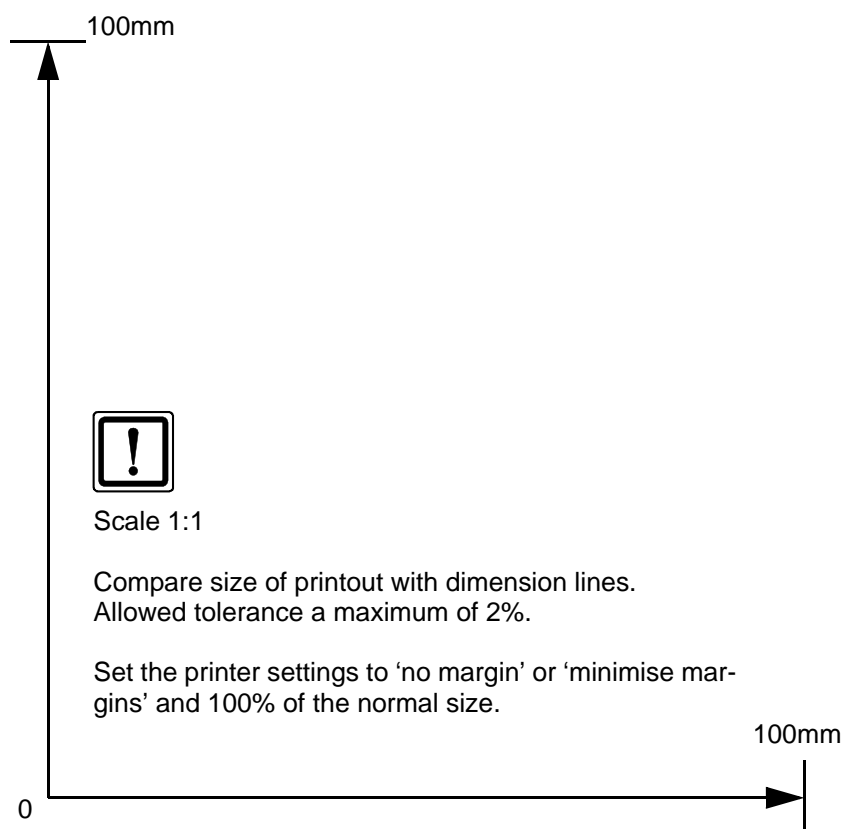
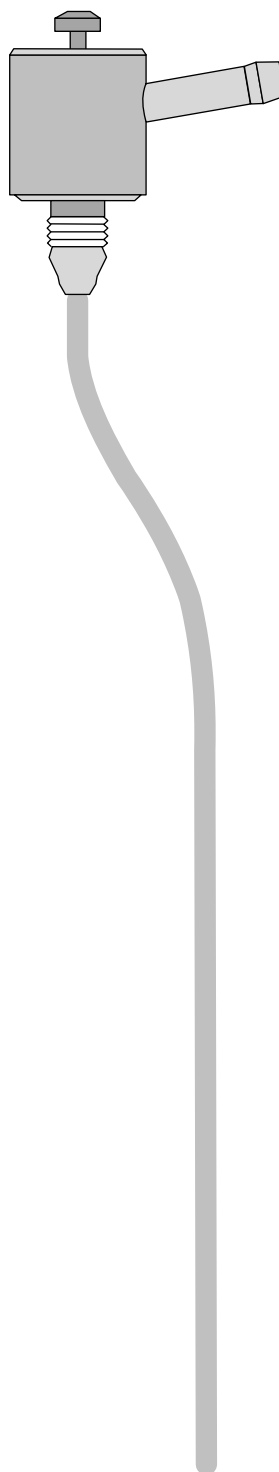
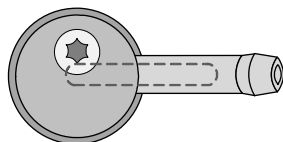

Operating Instructions for Automatic A/C

Please remove page and add to the vehicle operating instructions.

Note:

We recommend matching the heating time to the driving time.
Heating time = driving time

Example:

For a driving time of approx. 20 min. (in one direction), we recommend not exceeding a switch-on time of 20 min.

Passenger compartment monitoring, if installed, must be deactivated in addition to the vehicle settings for the heating operation.

For instructions on deactivation, please refer to the operating instructions of the vehicle.

Before parking the vehicle, make the following settings:

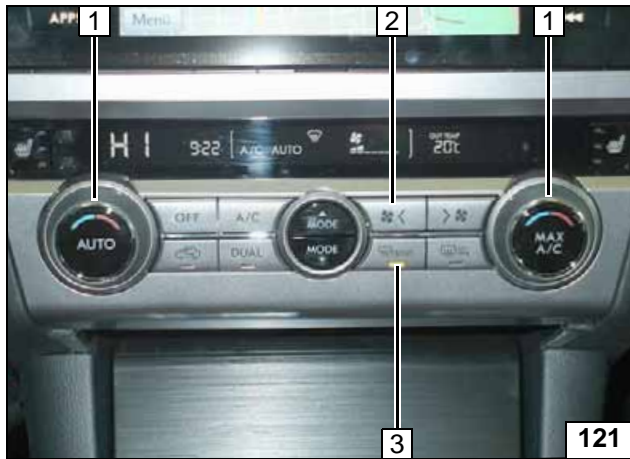

- 1 Set temperature on both sides to 'HI'
- 2 Set fan to level '2', or max. '3'
- 3 Air outlet to windscreen



A/C control panel

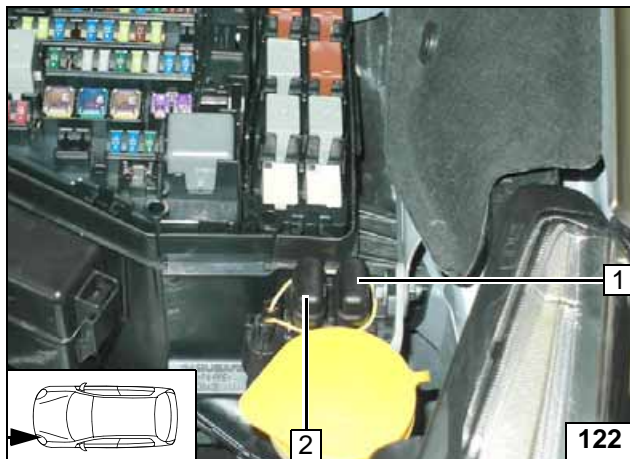

- 1 30A passenger compartment main fuse F2
- 2 20A heater fuse F1

Engine compartment fuses

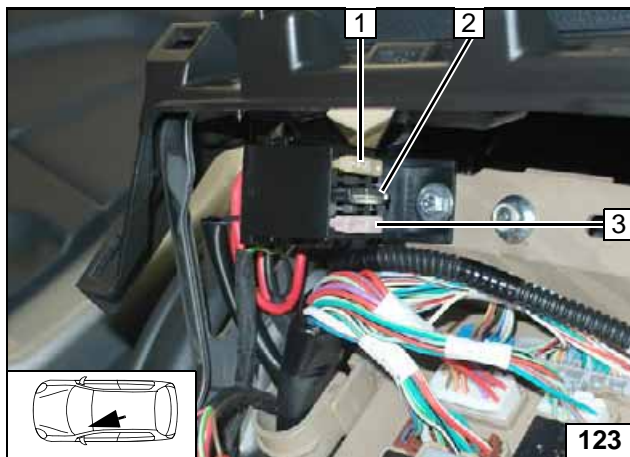

- 1 25A fan fuse F4
- 2 1A fuse F3 of heater control
- 3 3A fan fuse F5

Passenger compartment fuses

