

Water Heater

Thermo Top Evo Parking Heater



Installation Documentation Fiat 500X

Validity

Manufacturer	Model	Type	EG-BE No. / ABE
Fiat	500X	AXC1B	e3 * 2007 / 46 * 0318 ...

Motorisation	Fuel	Transmission type	Output in kW	Displacement in cm ³	Engine code
1.6 D Multijet	Diesel	SG	88	1598	

SG = manual transmission

From model year 2015
Left-hand drive vehicle

Verified equipment variants: Automatic air-conditioning
Front fog lights
Start Stop Function
2WD / 4WD

Not verified: Manual air-conditioning
Passenger compartment monitoring

Exclusion: 2.0 D Multijet

Total installation time: approx. 8 hours

Table of Contents

Validity	1	Preparing Bracket	15
Necessary Components	2	Preparing Installation Location	15
Installation Overview	2	Preparing Heater	16
Information on Total Installation Time	2	Installing Heater	17
Information on Operating and Installation Instructions	3	Combustion Air	19
Information on Validity	4	Fuel	20
Technical Information	4	Coolant Circuit	23
Explanatory Notes on Document	4	Exhaust Gas	27
Preliminary Work	5	Final Work	29
Heater Installation Location	5	Fuel Standpipe Template	30
Preparing Electrical System	6	Operating Instructions	31
Electrical System	9		
Fan Controller	10		
MultiControl CAR Option	12		
Remote Option (Telestart)	12		
Thermo Call Option	14		

Necessary Components

- Basic delivery scope of Thermo Top Evo based on price list
- Installation kit for Fiat 500X 2015 Diesel: **1324274A**
- Heater control in accordance with price list and upon consultation with end customer
- In case of Telestart, indicator lamp in accordance with price list and in consultation with end customer

Installation instructions:

- Arrange for the vehicle to be delivered with the tank only about $\frac{1}{4}$ full.
- The installation location of the push button in case of Telestart or Thermo Call should be confirmed with the end customer.
- Depending on the space required and the vehicle manufacturer's instructions, we recommend the use of a vehicle battery with a higher electrical capacity.

Installation Overview

Legend:

1. Heater
2. Engine compartment fuse holder
3. Passenger compartment relay and fuse holder
4. PWM GW
5. Circulating pump
6. MultiControl CAR
7. Metering pump

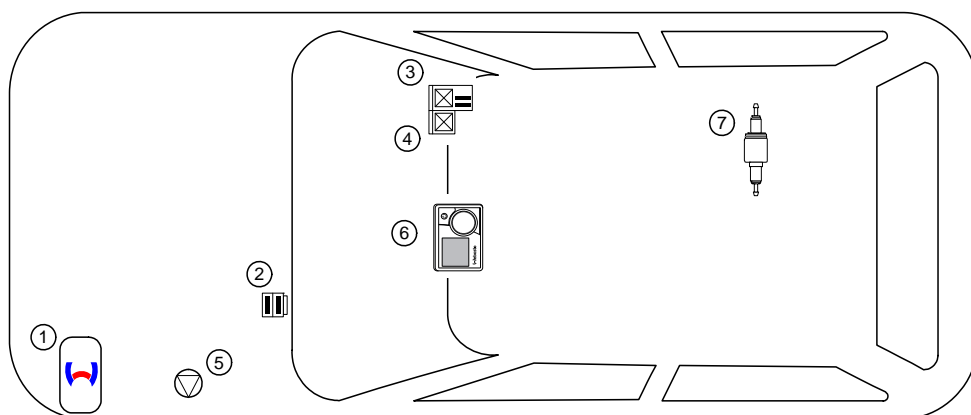

Information on Total Installation Time

The total installation time includes the time needed for mounting and demounting the vehicle-specific components, the heater specific installation time and all other times required for the system integration and initial start-up of the heater. The total installation time may vary for vehicle equipment other than provided.

Information on Operating and Installation Instructions

1 Important information (not complete)

1.1 Installation and repair



The improper installation or repair of Webasto heating and cooling systems can cause fire or the leakage of deadly carbon monoxide, leading to serious injury or death.



To install and repair Webasto heating and cooling systems you need to have completed a special company training course and have the appropriate technical documentation, special tools and special equipment.



Installation and repair may ONLY be carried out by persons trained and certified in a Webasto training course. NEVER try to install or repair Webasto heating or cooling systems if you have not completed a Webasto training course, you do not have the necessary technical skills and you do not have the technical documentation, tools and equipment available to ensure that you can complete the installation and repair work properly.

Only use genuine Webasto parts. See the Webasto air and water heaters accessories catalogue for this purpose.

1.2 Operation

To ensure safe operation, we recommend having the heater checked every two years by an authorised Webasto dealer, especially when used over a long period and/or under extreme environmental conditions.

Do not operate the heater in closed rooms due to the danger of poisoning and suffocation.

Always switch off the heater before refuelling.

The heater may only be used with the prescribed fuel diesel (DIN EN 590) or petrol (DIN EN 228).

The heater may not be cleaned with a high-pressure cleaner.

1.3 Please note

ALWAYS follow all Webasto installation and operating instructions and observe all warnings.

To become familiar with and understand all functions and properties of the heater, the operating instructions must be read carefully and observed at all times.

For proper, safe installation and repair work, the installation instructions with all warnings and safety information must be carefully read and observed at all times. Please always contact a workshop authorised by Webasto for all installation and repair work.

Important

Webasto shall assume no liability for defects, damage and injuries resulting from a failure to observe the installation, repair and operating instructions of the information contained in them.

This liability exclusion particularly applies to improper installations and repairs, installations and repairs by untrained persons or in the case of a failure to use genuine spare parts.

The liability due to culpable disregard to life, limb or health and due to damage or injuries caused by a wilful or reckless breach of duty remain unaffected, as does the obligatory product liability.

Installation should be carried out according to the general, standard rules of technology. Unless specified otherwise, fasten hoses, lines and wiring harnesses to original vehicle lines and wiring harnesses using cable ties. Insulate loose wire ends and tie back. Connectors on electronic components have to audibly click into place during installation.

Sharp edges should be fitted with rub protection. Spray unfinished body areas, e.g. drilled holes, with anti-corrosion wax (Tectyl 100K).

Observe the instructions and guidelines of the respective vehicle manufacturer for demounting and mounting vehicle specific components!

The initial startup is to be executed with the Webasto Thermo Test Diagnosis.

When installing a programmable control module (e.g. a PWM Gateway), the corresponding settings must be checked or adjusted.

2 Statutory regulations governing installation

Guidelines	Thermo Top Evo
Heating Directive ECE R122	E1 00 0258
EMC Directive ECE R10	E1 04 5627

Note

The regulations of these guidelines are binding in the scope of the Directive 70/156/EEC and/or 2007/46/EC (for new vehicle models from 29/04/2009) and should also be observed in countries in which there are no special regulations.

Important

Failure to follow the installation instructions will result in the invalidation of the type approval for the heater and therefore invalidation of the general **homologation of the vehicle**.

Note

The heater is licensed in accordance with paragraph 19, section 3, No. 2b of the StVZO (German Road Traffic Licensing Authority).

2.1 Excerpt from ECE regulation 122 (heating system) paragraph 5 for the installation of the heater

Beginning of excerpt.

ANNEX VII

REQUIREMENTS FOR COMBUSTION HEATERS AND THEIR INSTALLATION

1. GENERAL REQUIREMENTS

1.7.1. A clearly visible tell-tale in the operator's field of view shall inform when the combustion heater is switched on or off.

2. VEHICLE INSTALLATION REQUIREMENTS

2.1. Scope

2.1.1. Subject to paragraph 2.1.2, combustion heaters shall be installed according to the requirements of this Annex.

2.1.2. Vehicles of category O having liquid fuel heaters are deemed to comply with the requirements of this Annex.

2.2. Positioning of heater

2.2.1. Body sections and any other components in the vicinity of the heater must be protected from excessive heat and the possibility of fuel or oil contamination.

2.2.2. The combustion heater shall not constitute a risk of fire, even in the case of overheating. This requirement shall be deemed to be fulfilled if the installation ensures an adequate distance to all parts and suitable ventilation, by the use of fire resistant materials or by the use of heat shields.

2.2.3. In the case of M2 and M3 vehicles, the heater must not be positioned in the passenger compartment. However, an installation in an effectively sealed envelope which also complies with the conditions in paragraph 2.2.2 may be used.

2.2.4. The label referred to in paragraph 1.4 or a duplicate, must be positioned so that it can be easily read when the heater is installed in the vehicle.

2.2.5. Every reasonable precaution should be taken in positioning the heater to minimise the risk of injury and damage to personal property.

2.3. Fuel supply

2.3.1. The fuel filler must not be situated in the passenger compartment and must be provided with an effective cap to prevent fuel spillage.

2.3.2. In the case of liquid fuel heaters, where a supply separate to that of the vehicle is provided, the type of fuel and its filler point must be clearly labelled.

2.3.3. A notice, indicating that the heater must be shut down before refuelling, must be affixed to the fuelling point. In addition a suitable instruction must be included in the manufacturer's operating manual.

2.4. Exhaust system

2.4.1. The exhaust outlet must be located so as to prevent emissions from entering the vehicle through ventilators, heated air inlets or opening windows.

2.5. Combustion air inlet

2.5.1. The air for the combustion chamber of the heater must not be drawn from the passenger compartment of the vehicle.

2.5.2. The air inlet must be so positioned or guarded that blocking by rubbish or luggage is unlikely.

2.6. Heating air inlet

2.6.1. The heating air supply may be fresh or recirculated air and must be drawn from a clean area not likely to be contaminated by exhaust fumes emitted either by the propulsion engine, the combustion heater or any other vehicle source.

2.6.2. The inlet duct must be protected by mesh or other suitable means.

2.7. Heating air outlet

2.7.1. Any ducting used to route the hot air through the vehicle must be so positioned or protected that no injury or damage could be caused if it were to be touched.

2.7.2. The air outlet must be so positioned or guarded that blocking by rubbish or luggage is unlikely.

End of excerpt.

In multilingual versions the German language is binding.

Fiat 500X

Information on Validity

This installation documentation applies to Fiat 500X Diesel vehicles - for validity, see page 1 - from model year 2015 and later, assuming technical modifications to the vehicle do not affect installation, any liability claims excluded. Depending on the vehicle version and equipment, modifications may be necessary during installation with respect to this 'installation documentation'.

Vehicle and engine types, equipment variants and other specifications not listed in this installation documentation have not been tested. However, installation according to this installation documentation may be possible.

Technical Information

Special Tools

- Hose clamp pliers for auto-tightening hose clamps
- Hose clamp pliers for Clic hose clamps of type W
- Automatic wire stripper 0.2 - 6mm²
- Crimping pliers for cable lug / tab connector 0.5 - 6mm²
- Torque wrench for 2.0 - 10 Nm
- Hose clamping pliers
- Metric thread-setter kit
- Deep-hole marker
- Webasto Thermo Test Diagnosis with current software

Dimensions

- All dimensions are in mm.

Tightening torque values

- Tightening torque values of 5x13 heater bolts and 5x11 heater stud bolts = 8 Nm.
- Tightening torque value of 5x15 water connection piece retaining plate bolt = 7Nm.
- Tighten other bolt connections in accordance with manufacturer's instructions or in accordance with state-of-the-art technology.

Explanatory Notes on Document

You will find an identification mark on the outside top right corner of the page in question to provide you with a quick overview of the individual working steps.

Special features are highlighted using the following symbols:

Mechanical System



Electrical System



Coolant Circuit



Combustion Air



Fuel



Exhaust Gas



Software



Specific risk of injury or fatal accidents.



Specific risk due to electrical voltage.



Specific risk of damage to components.



Specific risk of fire and explosion.



Reference to general installation instructions of the Webasto components or to the manufacturer's vehicle-specific documents.



Reference to a special technical feature.



The arrow in the vehicle icon indicates the position on the vehicle and the viewing angle.



Tightening torque according to the manufacturer's vehicle-specific documents.



Preliminary Work

Vehicle



- Open the fuel tank cap.
- Ventilate the fuel tank.
- Close the fuel tank cap again.
- Depressurise the cooling system.
- Disconnect the battery and remove completely, including the carrier.
- Remove the windscreen wiper.
- Remove the windscreen wiper system.
- Remove the coolant reservoir cap.
- Remove the wiring harness pass through trim for the firewall on the left (5x clipped on).
- Remove the engine cover.
- Remove the bumper.
- Remove the left-hand headlight.
- Remove the right-hand underbody trim.
- Remove the side trim of the instrument panel on the left and on the right.
- Remove the footwell trim on the driver's and front passenger's side.
- Remove the glove box.
- Remove the rear bench seat.
- Open the right-hand tank-fitting service lid.

Heater

- Remove years that do not apply from the type and duplicate label.
- Attach the duplicate label (type label) visibly in the appropriate place in the engine compartment.

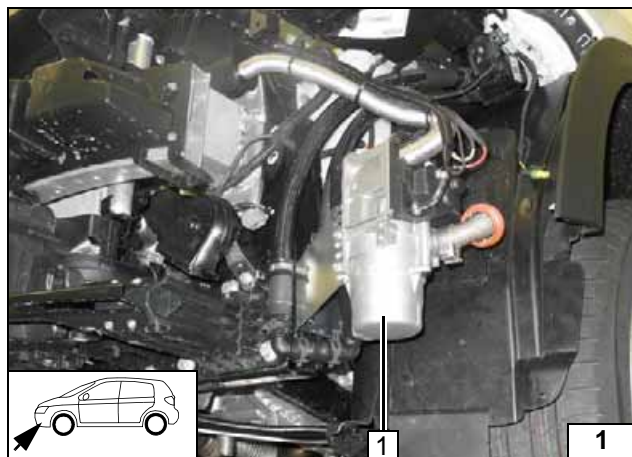

Heater Installation Location

- 1 Heater

Installation
location

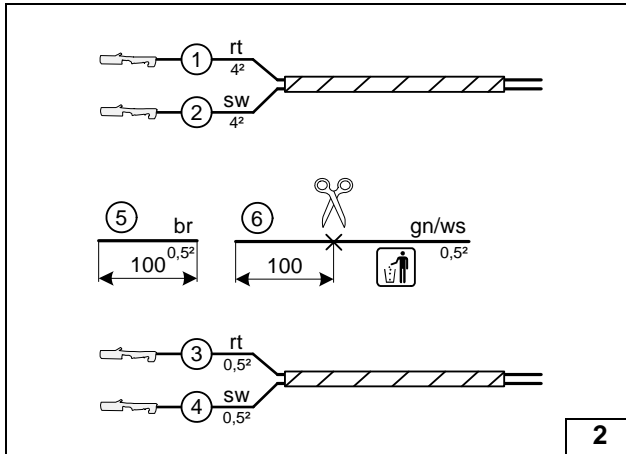
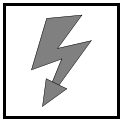

Preparing Electrical System

Wire sections retain their numbering in the entire document.

Produce all following electrical connections as shown in the wiring diagram.

- ① Red (rt) wire of fan wiring harness
- ② Black (sw) wire of fan wiring harness
- ③ Red (rt) wire from wiring harness of PWM control
- ④ Black (sw) wire from wiring harness of PWM control

Cutting to length / assigning wires

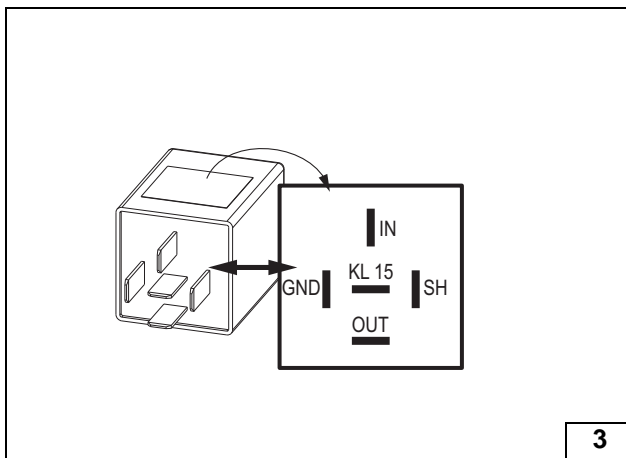

Check the PWM Gateway settings when starting up the heater and adjust if necessary.

Settings:

- Duty cycle: 35%
- Frequency: 1200Hz
- Voltage: 4.2V
- Function: High side

View of PWM-GW

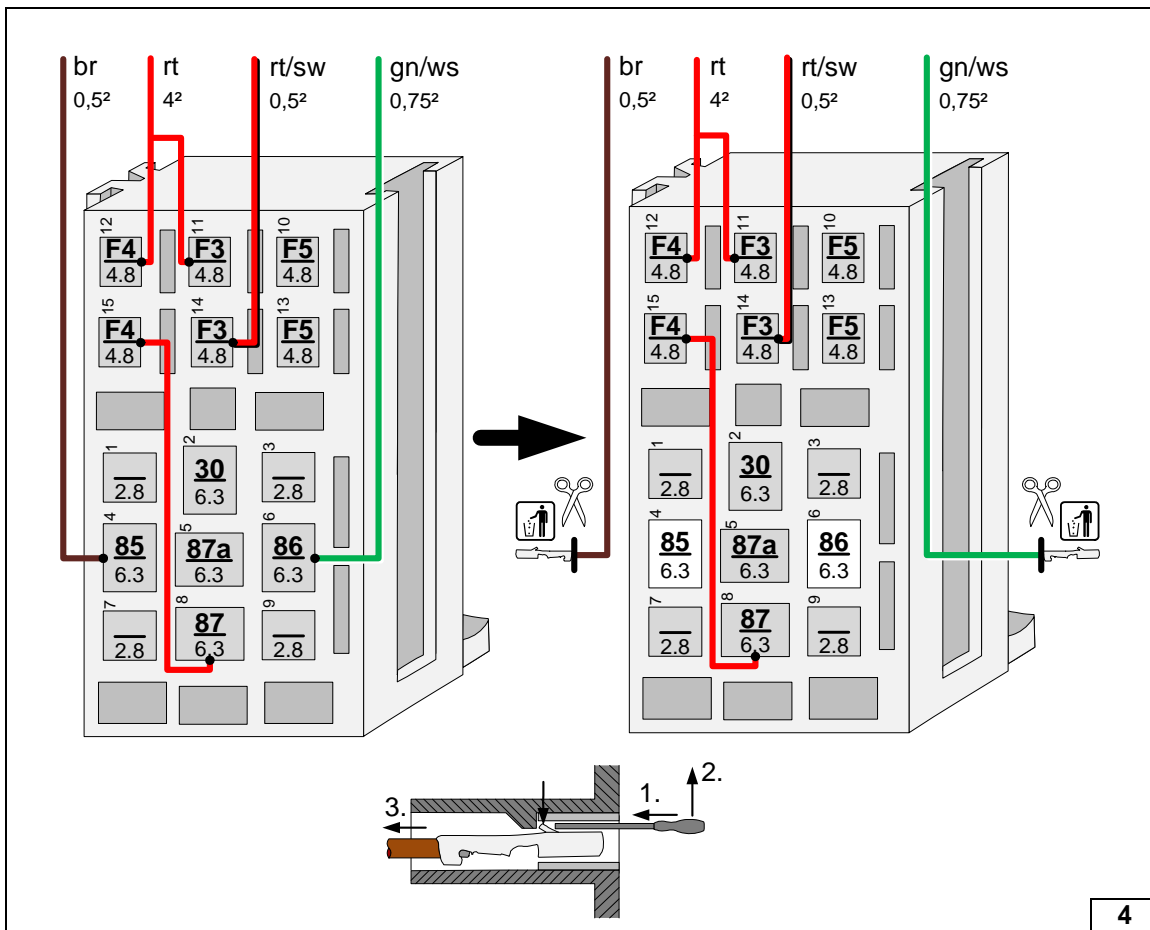

Preparing passenger compartment relay and fuse holder

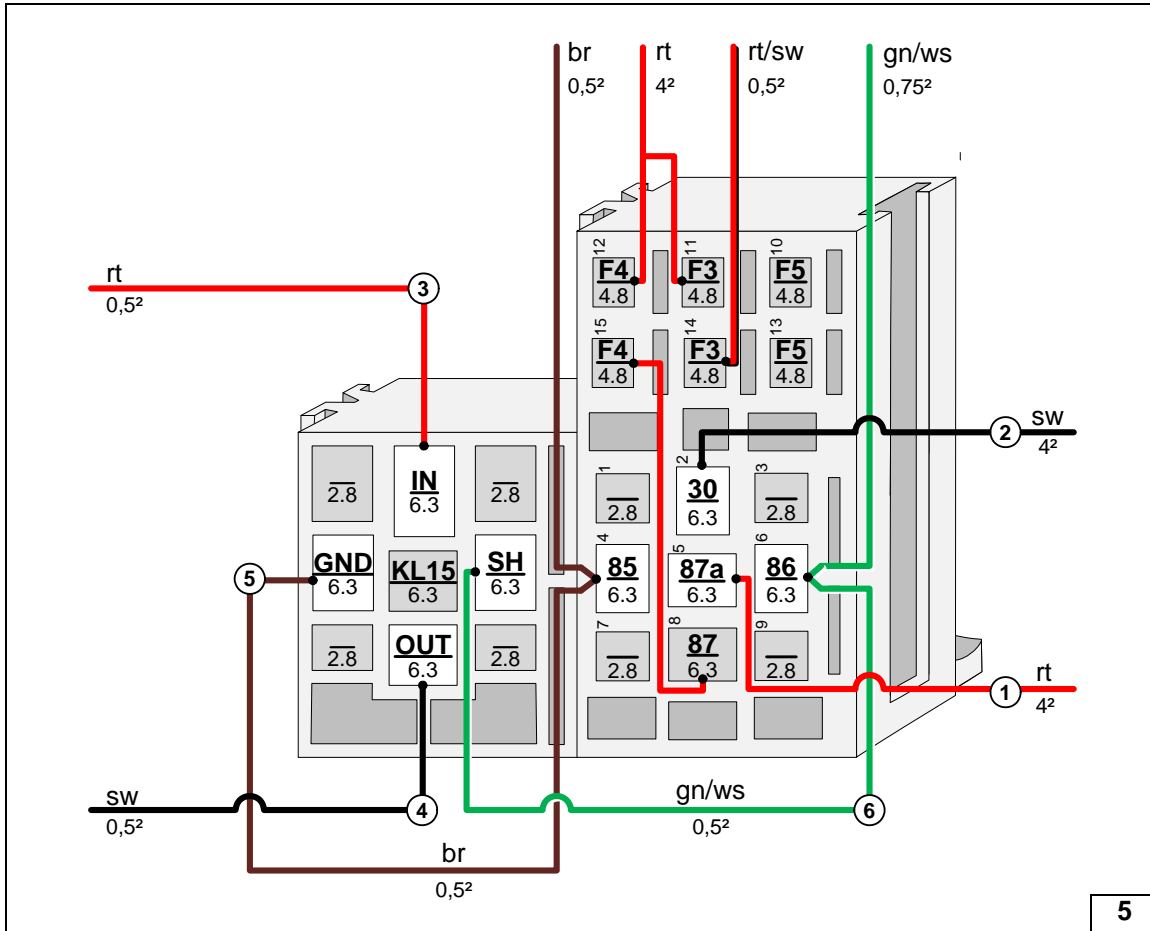

Connecting wires to sockets of PWM GW and passenger compartment relay and fuse holder, interlocking sockets

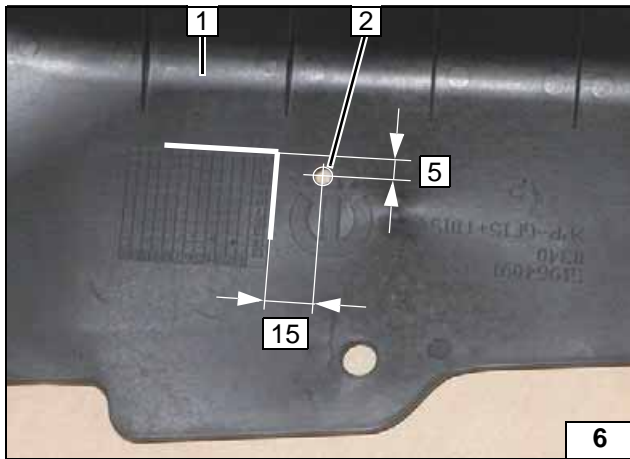

- 1 Trim of wiring harness pass through for the firewall
- 2 5mm dia. hole

Hole for engine compartment fuse holder

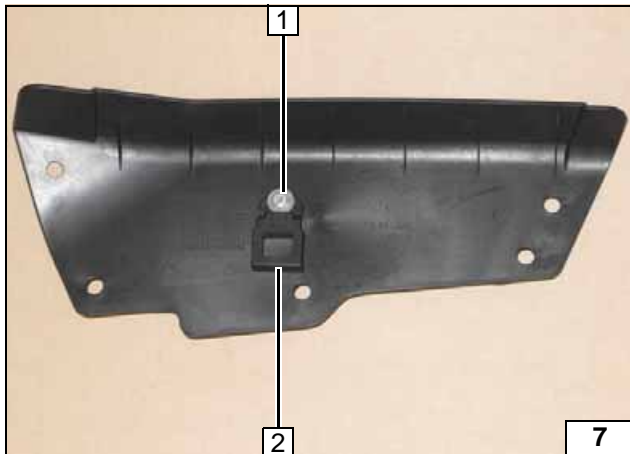

- 1 M5x16 bolt, large diameter washer [2x], nut
- 2 Retaining plate of fuse holder

Installing fuse holder retaining plate

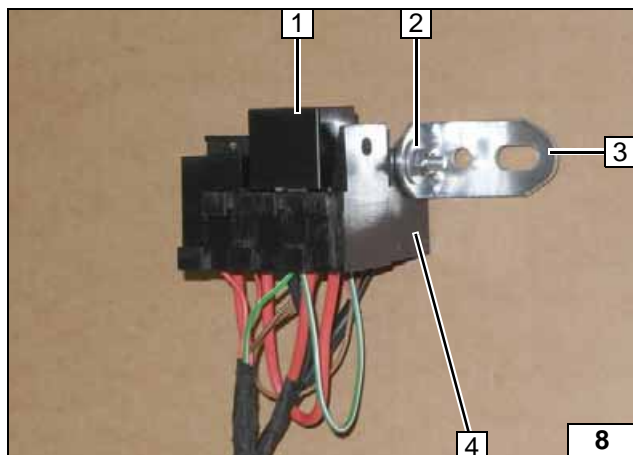

- 1 K1 relay inserted
- 2 M5x16 bolt, large diameter washer [2x], nut
- 3 Angle bracket
- 4 PWM GW socket

Installing angle bracket

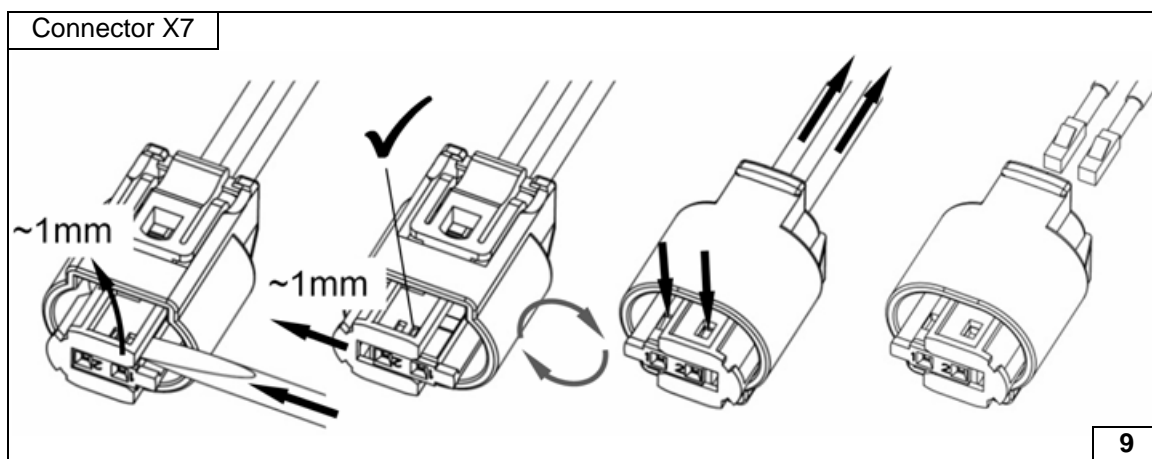

Dismantling metering pump connector



Electrical System



Engine compartment fuse holder

Route heater wiring harness **3** and heater control through original vehicle wiring duct **2** in the coolant reservoir.

- 1 Trim of wiring harness pass through for the firewall, mounted
- 4 Cable tie
- 5 Fuses F1-2

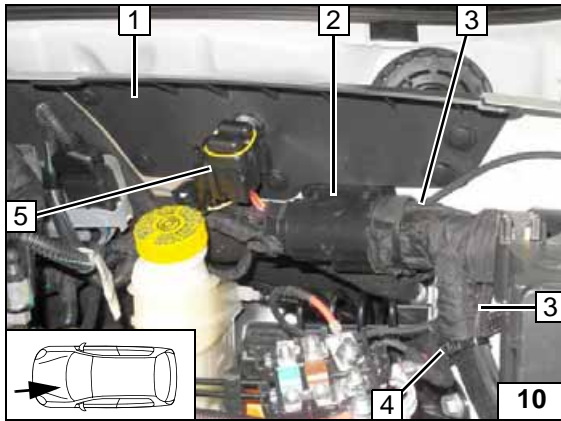

Wiring harness pass through

- 1 Wiring harness of heater, heater control
- 2 Protective rubber plug
- 3 Original vehicle wiring duct

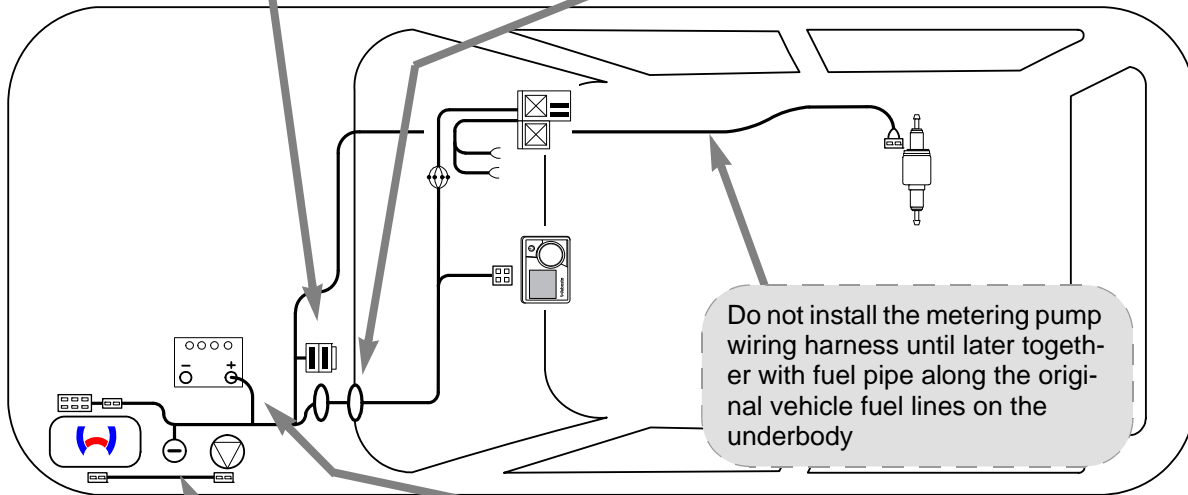
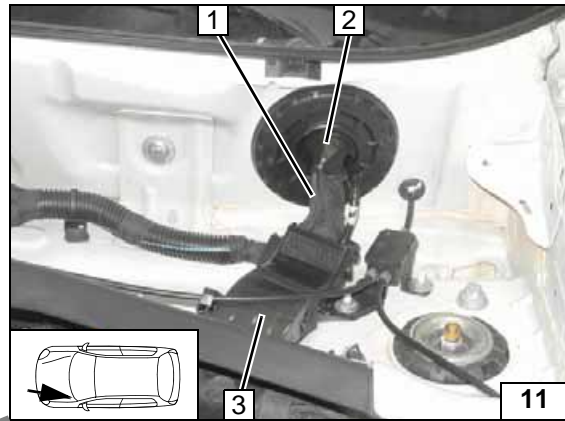

Wiring harness routing diagram

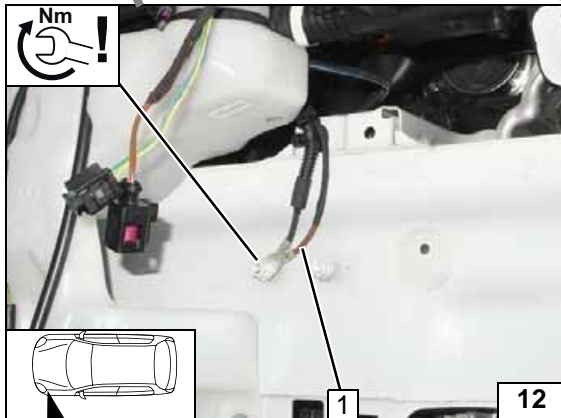

Earth wire

- 1 Earth wire on original vehicle earth support point

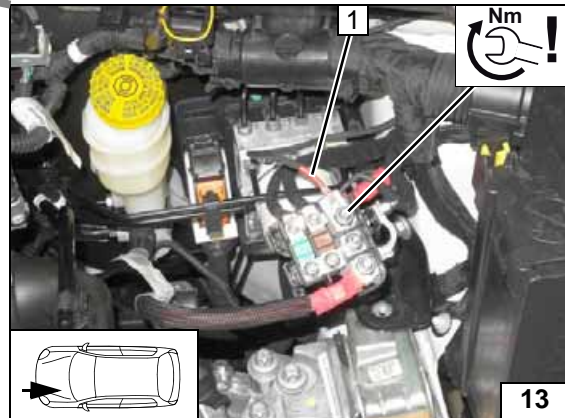

Positive wire

- 1 Positive wire on positive battery distributor



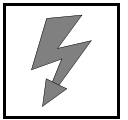

Fan Controller



Wiring diagram

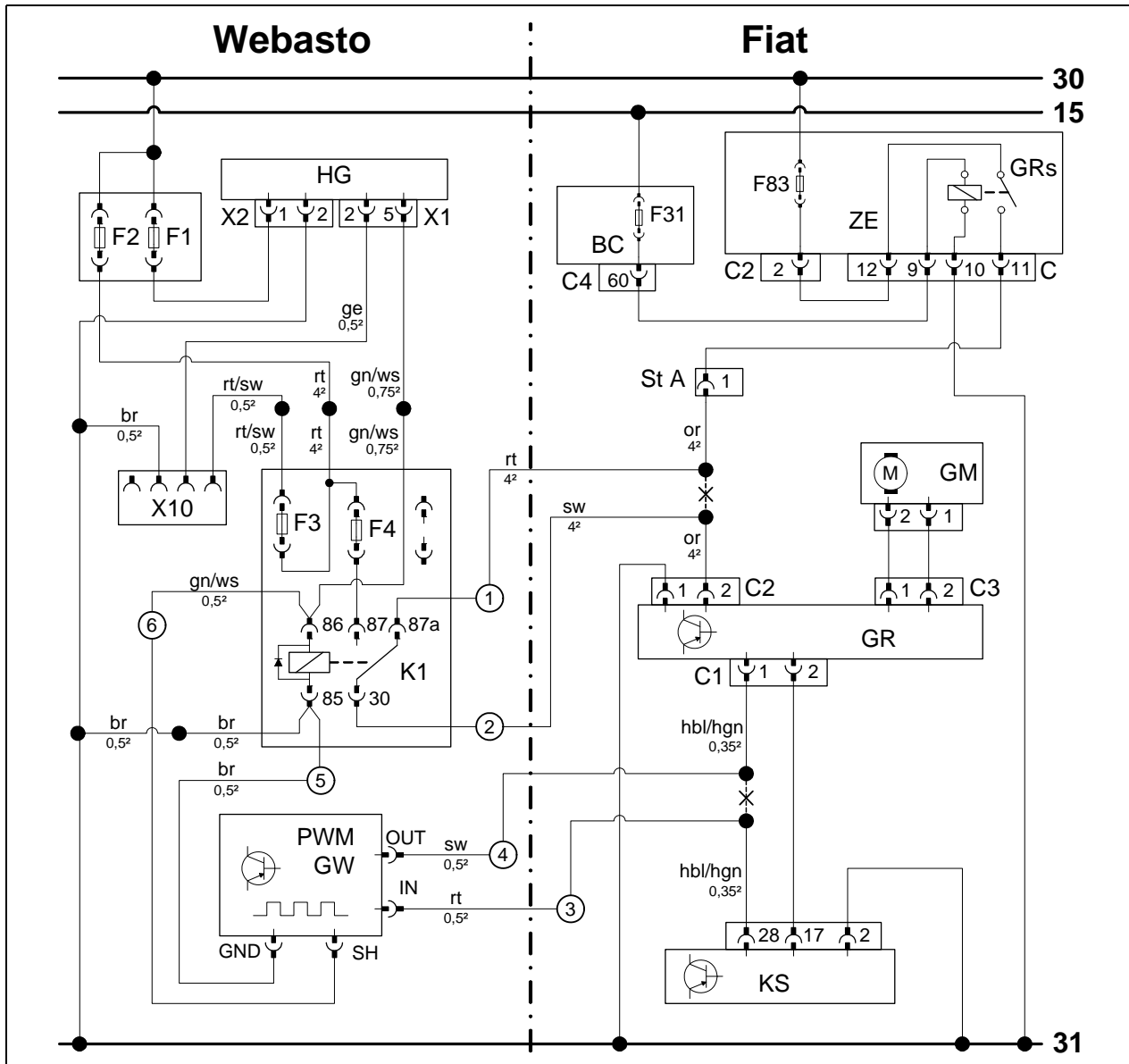

Webasto components		Vehicle components		Colours and symbols	
HG	TT-Evo heater	ZE	Central electrical box	rt	red
X1	6-pin heater connector	GRs	Fan relay	sw	black
X2	2-pin heater connector	F83	40A fuse	ge	yellow
F1	20A fuse	C2	Connector of ZE	gn	green
F2	30A fuse	C	Connector of ZE	or	orange
X10	4-pin heater control connector	BC	Body computer	ws	white
F3	1A fuse	F31	7.5A fuse	br	brown
F4	25A fuse	C4	Connector of BC	hbl	light blue
K1	Fan relay	St A	Connector	hgn	light green
PWM GW	Pulse width modulator	GM	Fan motor		
		GR	Fan controller		
		C1	2-pin connector of GR		
		C2	2-pin connector of GR		
		C3	2-pin connector of GR		
		KS	A/C control unit		
Settings of PWM GW:				X	Cutting point
Duty cycle:	35%				
Frequency:	1200Hz				
Voltage:	4.2V				
Function:	High side				Wiring colours may vary.

Legend

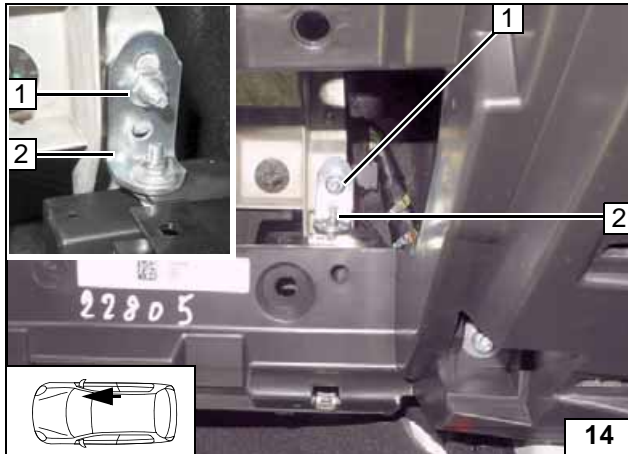
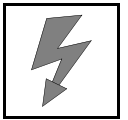

- 1 M6 flanged nut on original vehicle stud bolt
- 2 Angle bracket

Installing passenger compartment relay and fuse holder

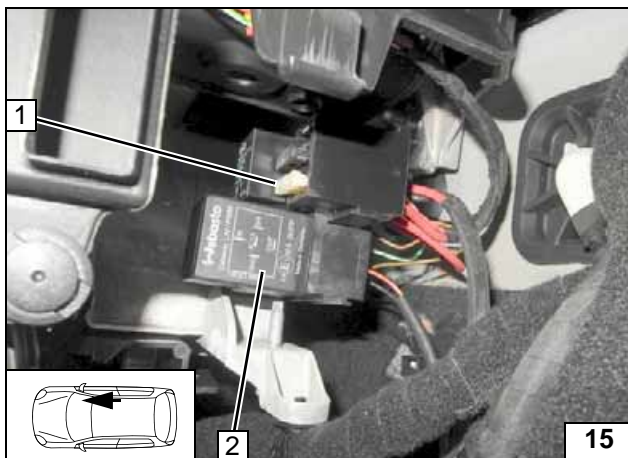

- 1 25A fuse F4
- 2 PWM GW

Installing fuse F4 and PWM GW

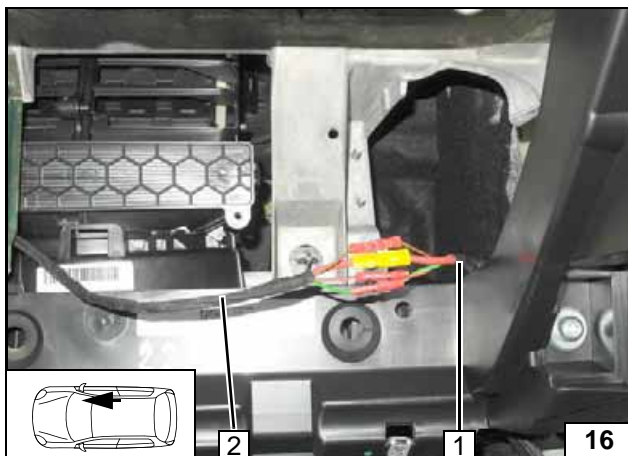

- 1 Wiring harness of passenger compartment relay and fuse holder
- 2 Heater wiring harness

Connecting same colour wires of wiring harnesses

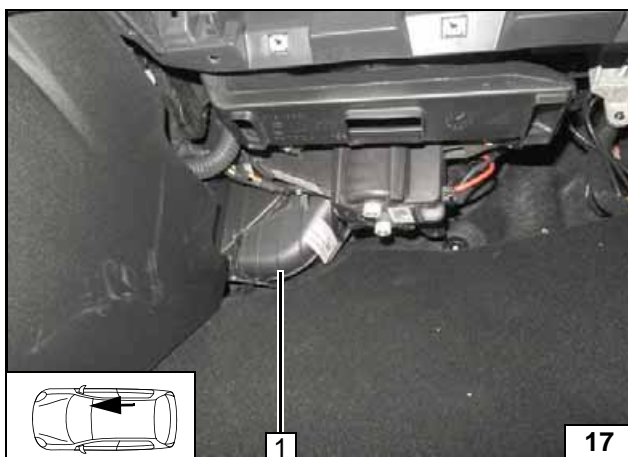

- 1 Remove cover of fan controller

Removing cover

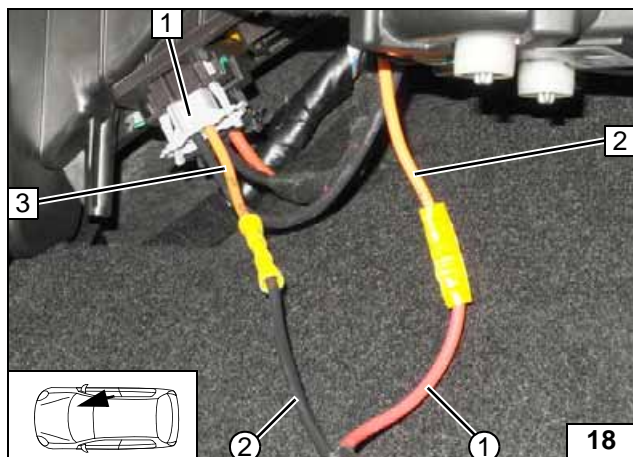

- 1 2-pin grey connector C2 of fan controller
- 2 Orange (or) wire of connector C from ZE, pin 11
- 3 Orange (or) wire of C2 connector, pin 2
- ① Red (rt) wire of K1/87a, fan wiring harness
- ② Black (sw) wire of K1/30, fan wiring harness

**Connect-
ing fan con-
troller**

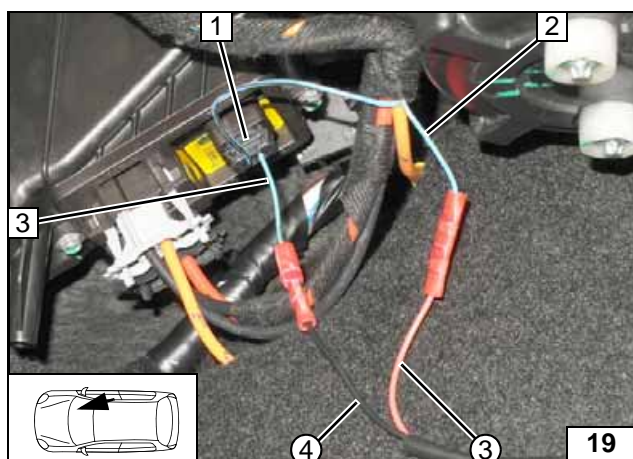

- 1 2-pin black connector C1 of fan controller
- 2 Light blue/light green (hbl/hgn) wire of KS, pin 28
- 3 Light blue/light green (hbl/hgn) wire of connector C1, pin 1
- ③ Red (rt) wire of PWM GW/IN, PWM control wiring harness
- ④ Black (sw) wire of PWM GW/OUT, PWM control wiring harness

**Connect-
ing fan con-
troller**

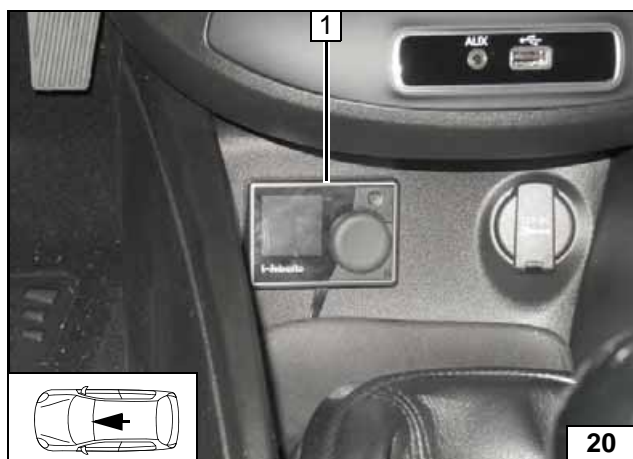

MultiControl CAR Option

- 1 MultiControl CAR



**Installing
MultiControl
CAR**



Remote Option (Telestart)

Version 1

Fasten receiver 1 with double-sided adhesive tape.



**Installing
receiver**

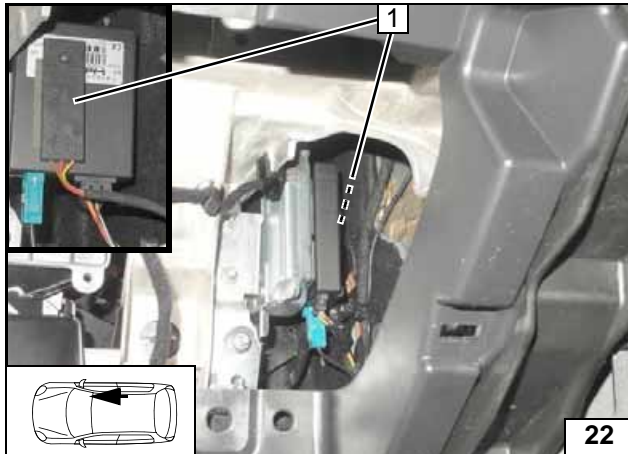
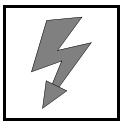

Temperature sensor T100 HTM

Fasten temperature sensor 1 with double-sided adhesive tape.



Installing temperature sensor

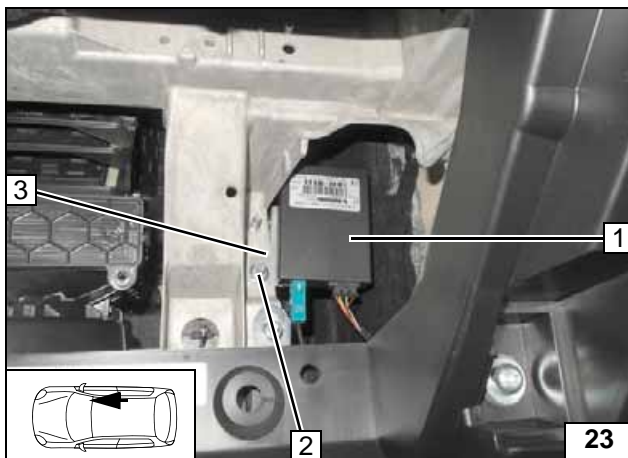

Version 2

- 1 Receiver
- 2 M6 flanged nut on original vehicle stud bolt
- 3 Bracket of receiver



Installing receiver

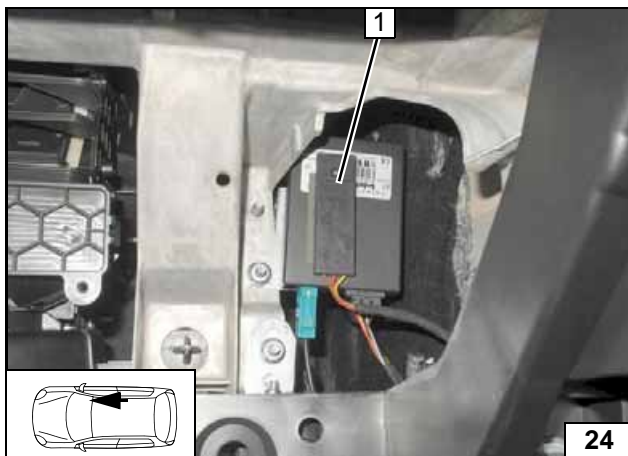

Temperature sensor T100 HTM

Fasten temperature sensor 1 with double-sided adhesive tape.



Installing temperature sensor

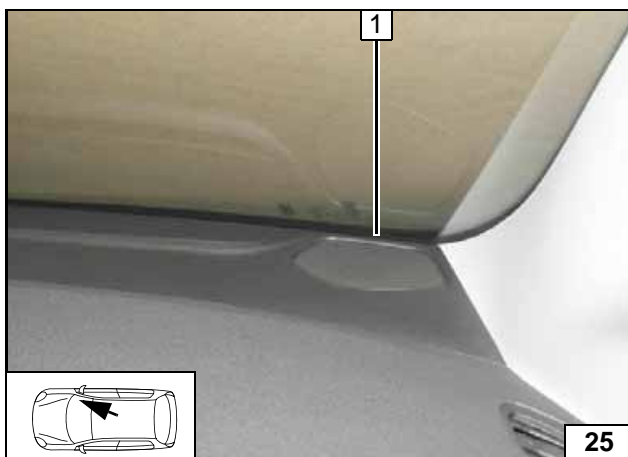

All versions

- 1 Aerial



Installing aerial

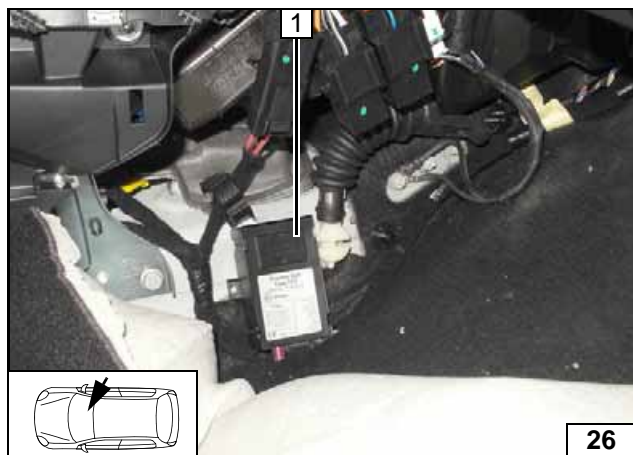

Thermo Call Option

Fold back floor covering.
Fasten receiver 1 with double-sided adhesive tape.



Installing receiver

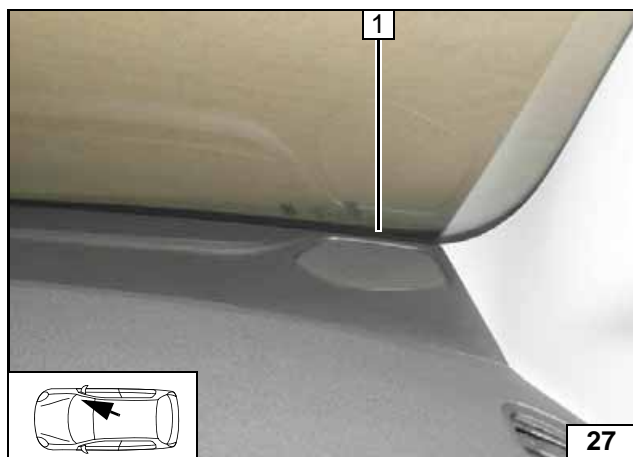

1 Aerial

Installing aerial

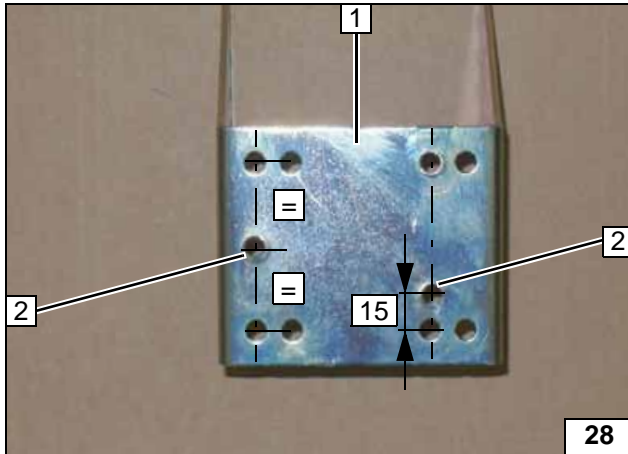
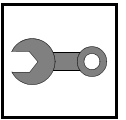

Preparing Bracket

- 1 Bracket
- 2 Copy hole pattern, drill 7 mm dia. hole [2x]

Copying hole pattern

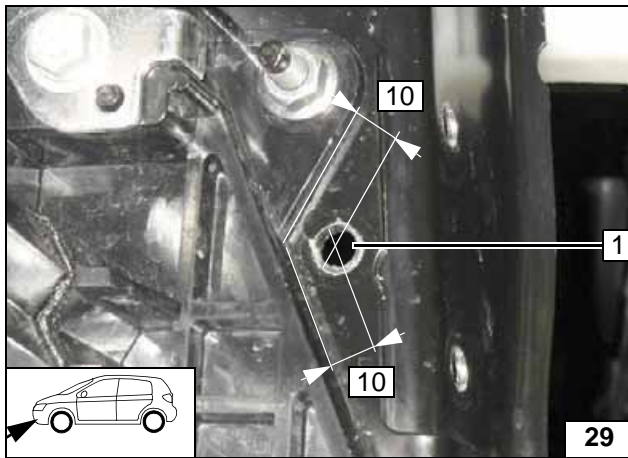

Preparing Installation Location

- 1 Copy hole pattern, 7 mm dia. hole

Copying hole pattern

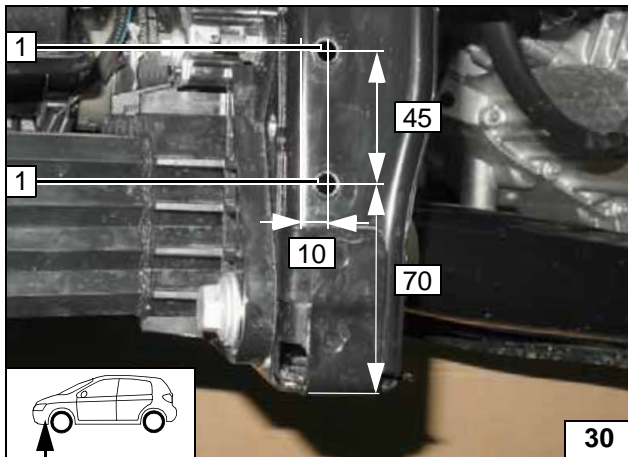

- 1 Copy hole pattern, drill 7 mm dia. hole [2x]

Copying hole pattern

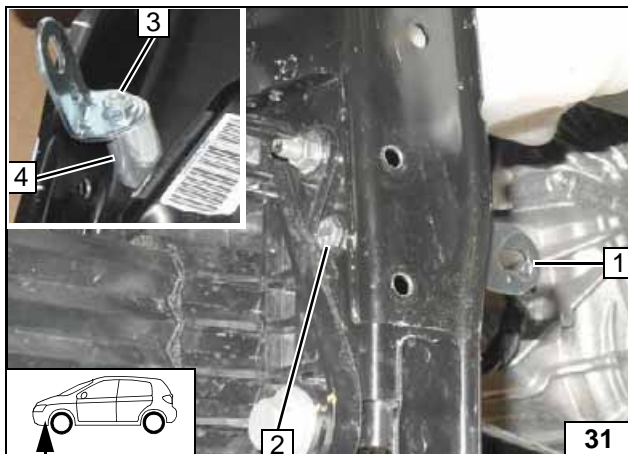

- 1 Angle bracket
- 2 M6x50 bolt
- 3 Flanged nut
- 4 30 mm shim

Installing angle bracket

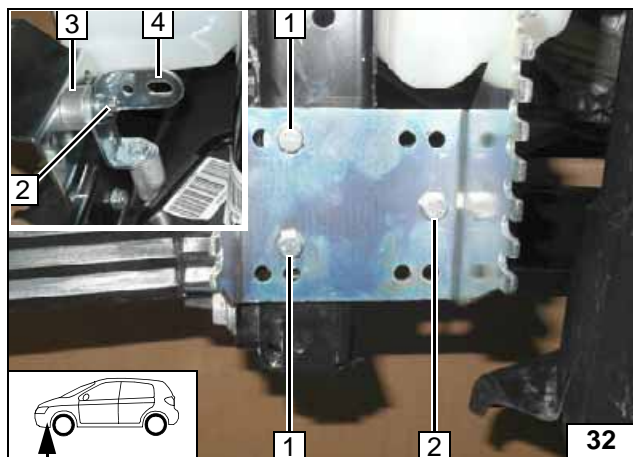
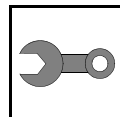

Insert one shim each [2x] between vehicle and bracket at position 1 .

- 1 M6x20 bolt, 10 mm shim, flanged nut [2x each]
- 2 M6x30 bolt, 15 mm shim, flanged nut
- 3 15 mm shim
- 4 Angle bracket for exhaust gas



Installing bracket

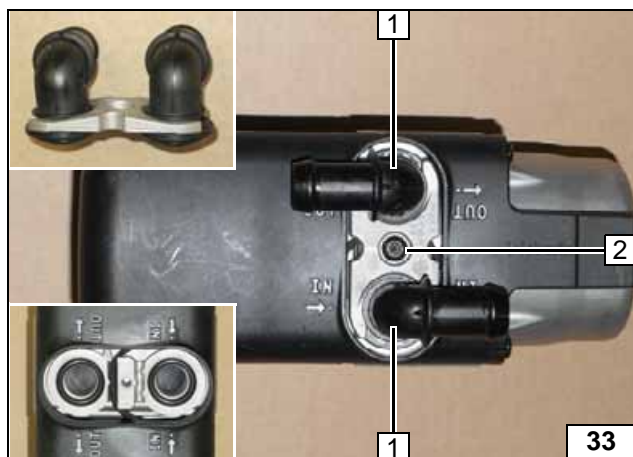

Preparing Heater

- 1 Water connection piece, sealing ring [2x each]
- 2 5x15 self-tapping bolt, retaining plate of water connection piece



Installing water connection piece

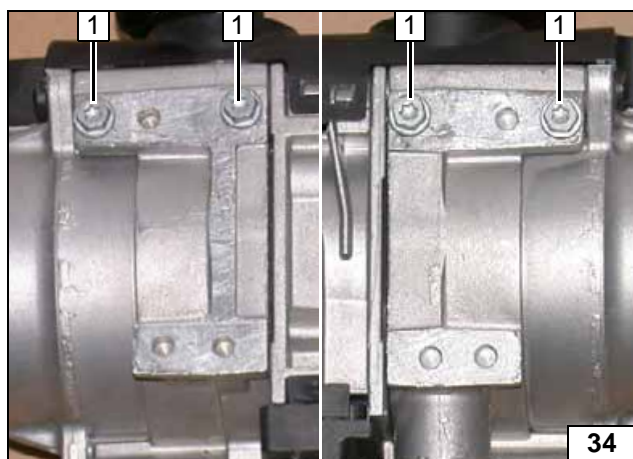

Screw 5x13 self-tapping bolts 1 [4x] into existing holes by a maximum of 3 thread turns.



Premounting bolts loosely

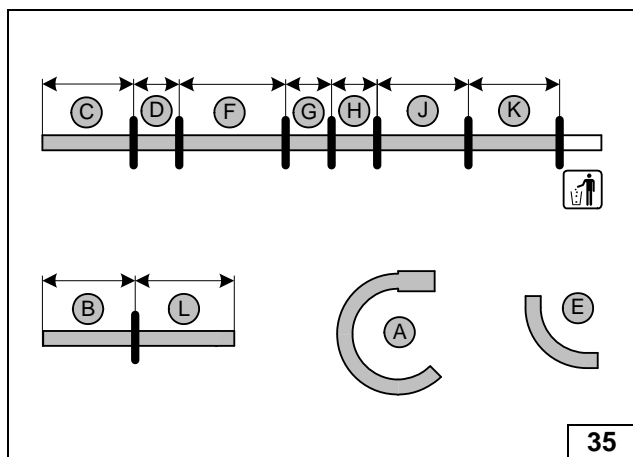

- A = 180°, 15x20mm dia.
- B = 300
- C = 360
- D = 105
- E = 90°, 18x18mm dia.
- F = 590
- G = 60
- H = 80
- J = 320
- K = 360
- L = 300



Cutting hoses to length

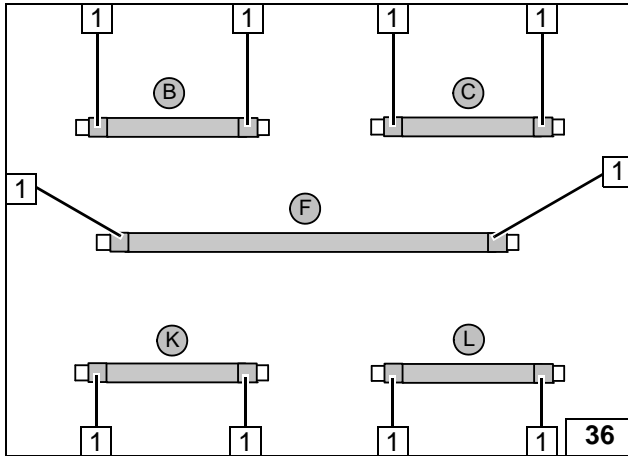
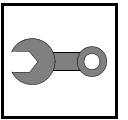

Braided protection hoses onto hose **B, C, F, K** and **L** and cut to length. Cut heat shrink plastic tubing to size.

- 1 50 mm long heat shrink plastic tubing [10x]



Preparing hoses

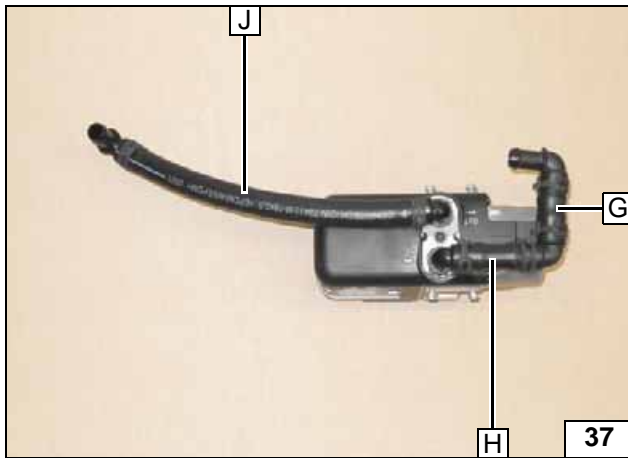

All spring clips 25 mm dia.
All connecting pipes 90°, 18x18 mm



Premounting hoses

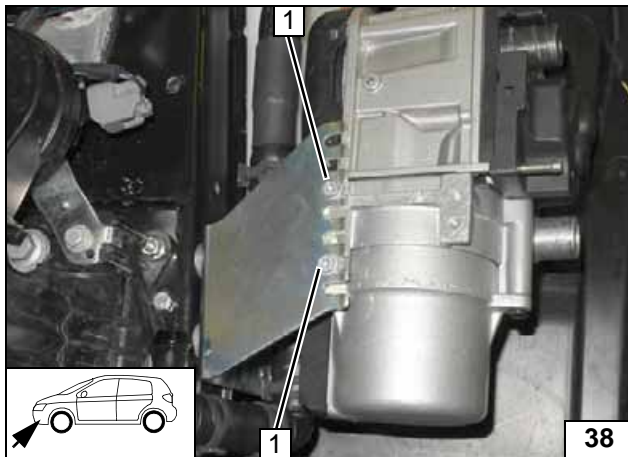

Installing Heater

- 1 5x13 self-tapping bolt [2x]

Installing heater

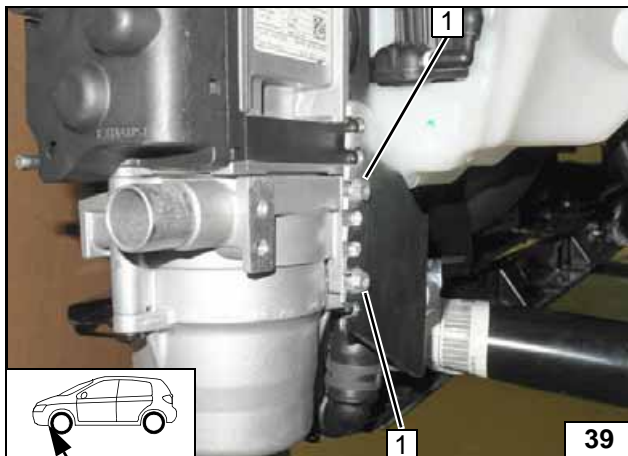

- 1 5x13 self-tapping bolt [2x]

Installing heater

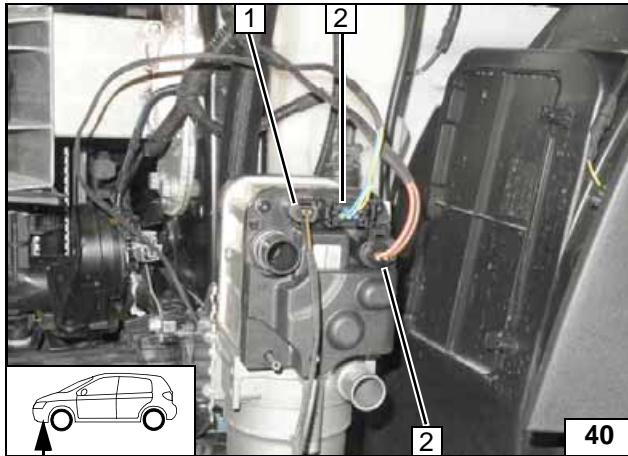
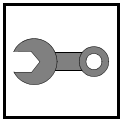

- 1 Connector of circulating pump wiring harness
- 2 Connector of heater wiring harness [2x]

Installing wiring harnesses

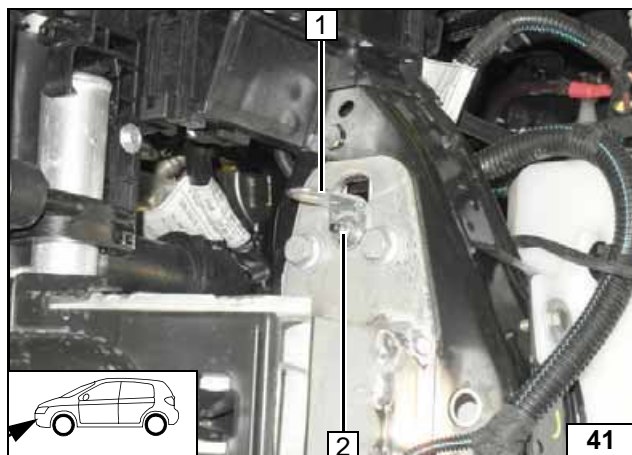
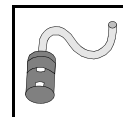

Combustion Air

- 1 Angle bracket
- 2 Original vehicle stud bolt and nut

Installing angle bracket

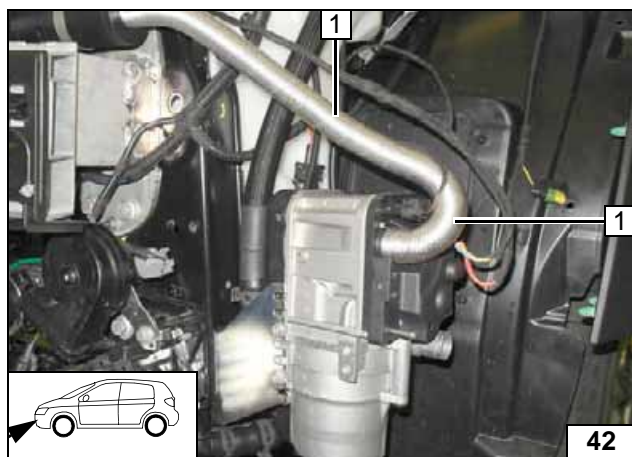

- 1 Combustion air pipe



Installing combustion air pipe

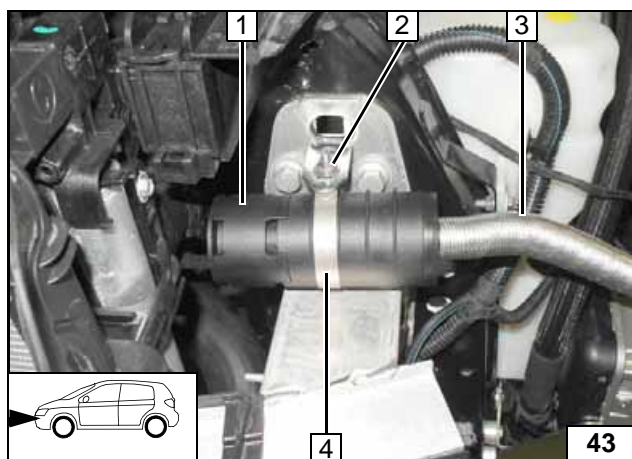

- 1 Silencer
- 2 M5x16 bolt, large diameter washer, flanged nut
- 3 Combustion air pipe
- 4 51 mm dia. clamp



Installing silencer

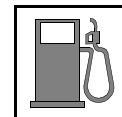

Fuel



Open the vehicle's fuel tank cap, ventilate the tank and then re-close the tank lock.

Catch any fuel running off in an appropriate container.



Route fuel line and metering pump wiring harness so that they are protected against stone impact. Unless specified otherwise, always fasten using cable ties.

Provide rub protection for fuel line and wiring harness in areas where there are sharp edges.

The fuel line and wiring harness are routed to the metering pump as shown in the wiring harness routing diagram.

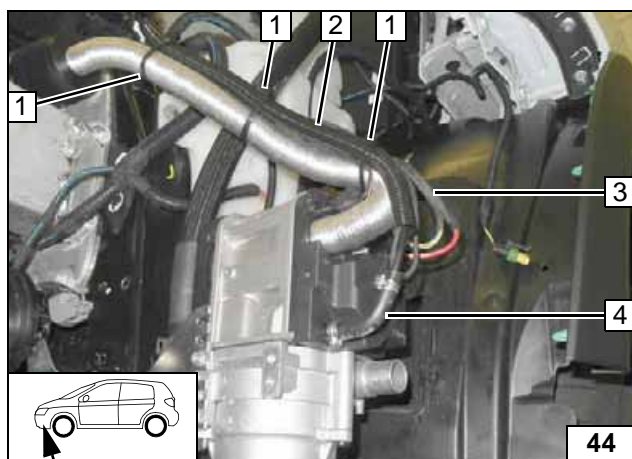

Pull fuel line and wiring harness of metering pump in 10mm dia. corrugated tube **2** and route in the engine compartment. Secure corrugated tube and heater wiring harness **3** to combustion air pipe with cable tie **1**.

4 Fuel line, 90° moulded hose, 10mm dia. clamp [2x]



**Connect-
ing heater**



Route fuel line and wiring harness of metering pump in 10mm dia. corrugated tube **1** on original vehicle wiring harness to the right vehicle side (see marking) and further along original vehicle lines to the underbody.



**Routing
lines**

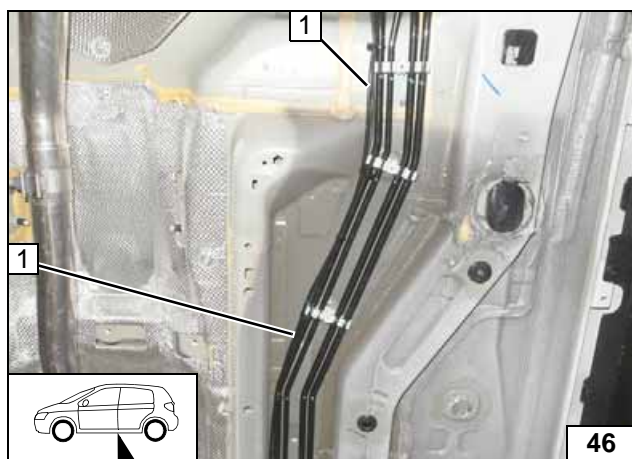

Route fuel line and wiring harness of metering pump **1** along original vehicle fuel lines to the installation location of the metering pump.



**Routing
lines**

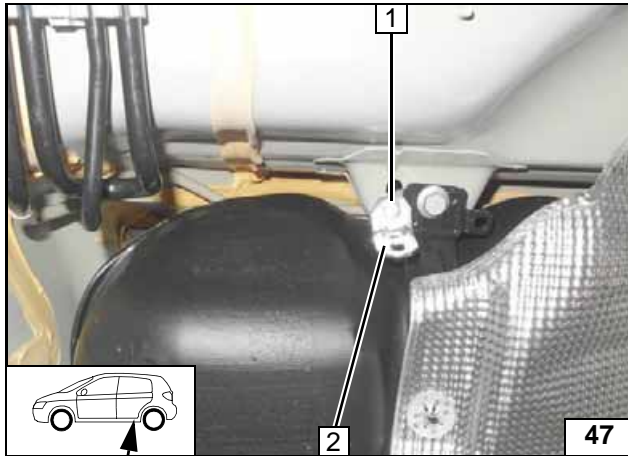

- 1 M6x16 bolt, flanged nut, existing hole
- 2 Angle bracket

Installing angle bracket

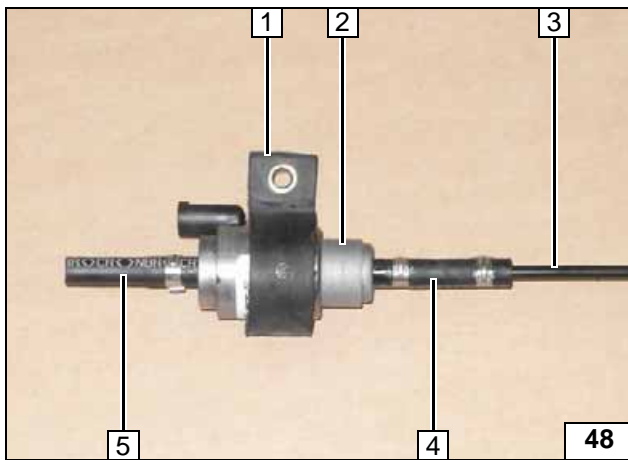

Cut 800 mm from fuel line.

- 1 Metering pump mount
- 2 Metering pump
- 3 800 mm long fuel line
- 4 Hose section, 10mm dia. clamp [2x]
- 5 Hose section, 10 mm dia. clamp

Premounting metering pump

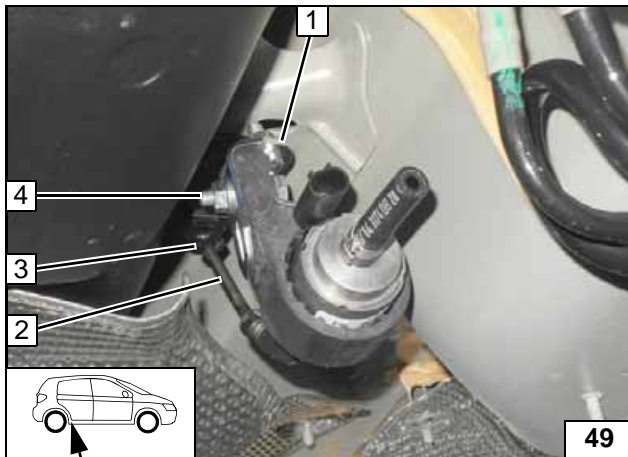

Route fuel line 2 upwards to the fuel tank sending unit and fasten with cable tie 3 using existing hole.

- 1 Angle bracket
- 4 M6x25 bolt, flanged nut

Installing metering pump

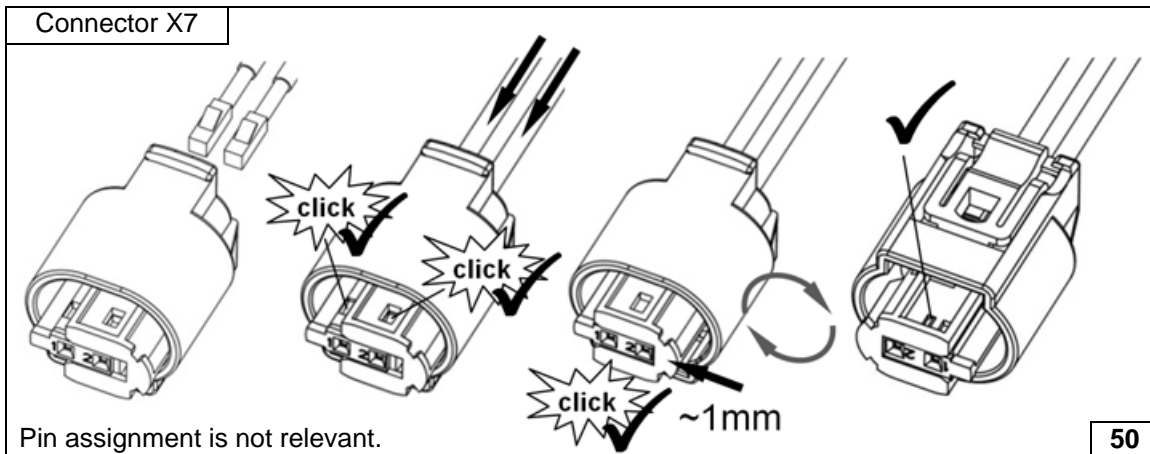

Pin assignment is not relevant.

Completing metering pump connector

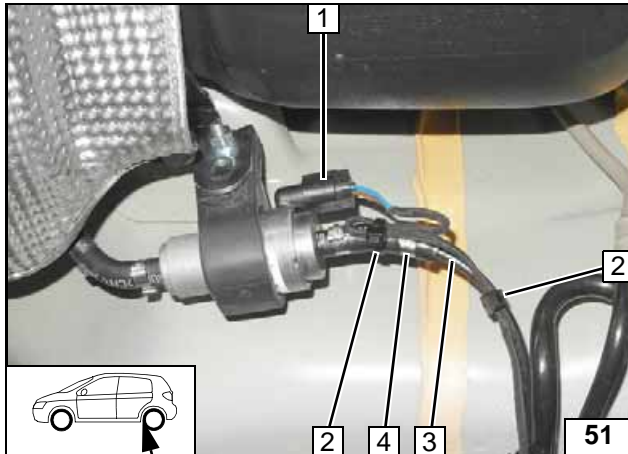
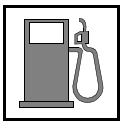

- 1 Wiring harness of metering pump, connector X7 mounted
- 2 Cable tie [2x]
- 3 Fuel line of heater
- 4 10mm dia. clamp



Installing metering pump

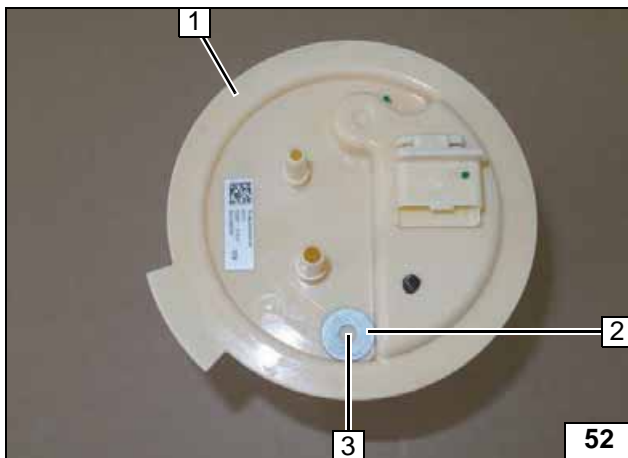

Remove fuel tank sending unit 1 in accordance with manufacturer's instructions.

- 2 Large diameter washer with outer dia. d_a 21.6 mm
- 3 Copy hole pattern, 6mm dia. hole



Copying hole pattern

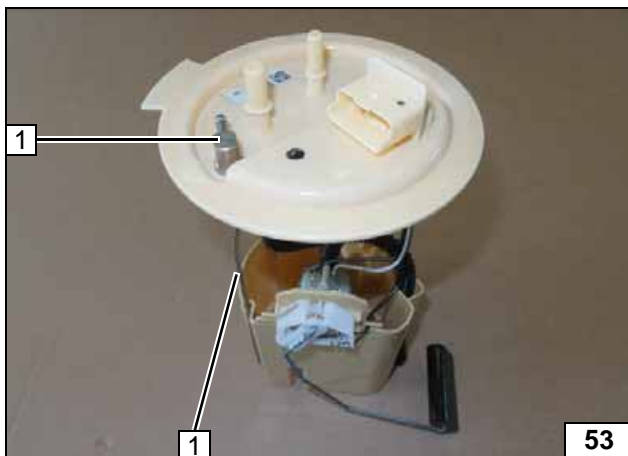

Bend fuel standpipe 1 according to template and cut it to length.



Installing fuel standpipe

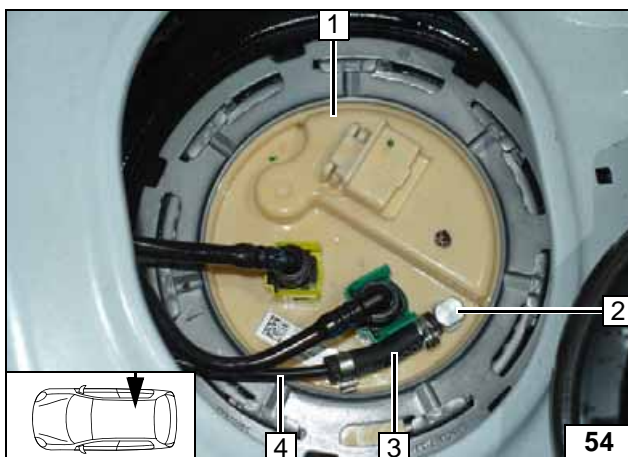

Install fuel tank sending unit 1 in accordance with manufacturer's instructions.

- 2 Fuel standpipe
- 3 Moulded hose, 10 mm dia. clamp [2x]
- 4 Fuel line



Connecting fuel line



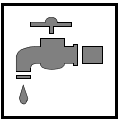

Coolant Circuit





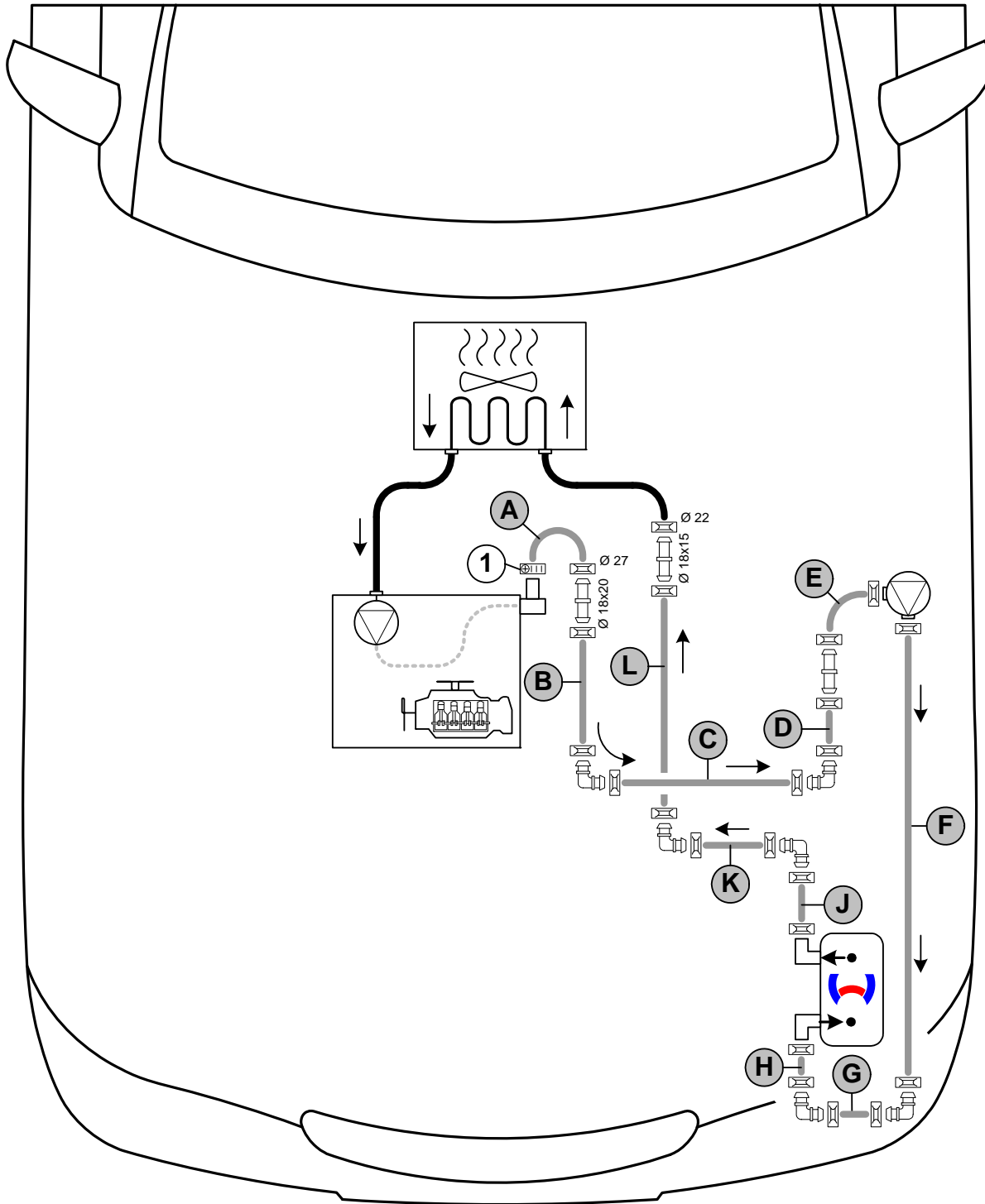

Any coolant running off should be collected in an appropriate container. Route hoses kink-free. Unless specified otherwise, always fasten using cable ties. Position clamps so that other hoses cannot be damaged. The heater must be filled with coolant when installing the hoses.

The connection should be modelled on an 'inline' circuit and based on the following diagram:



Hose routing diagram

All spring clips without a specific designation  = 25mm dia.
 All connecting pipes without a specific designation  and  = 18x18mm dia.
 1 = Hose clamp  = 16-27 mm dia.



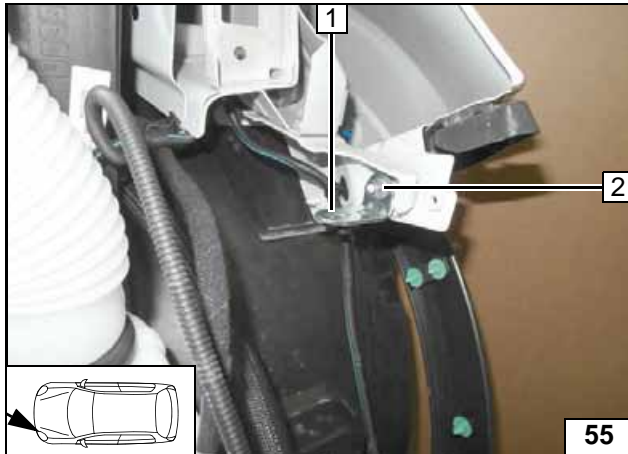

- 1 Angle bracket
- 2 Original vehicle bolt, flanged nut

Installing angle bracket

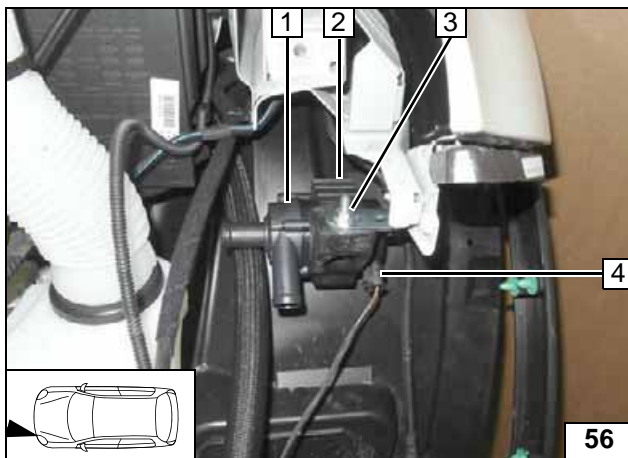

- 1 Circulating pump
- 2 Circulating pump mount
- 3 M6x25 bolt, flanged nut
- 4 Connector of circulating pump wiring harness

Installing circulating pump

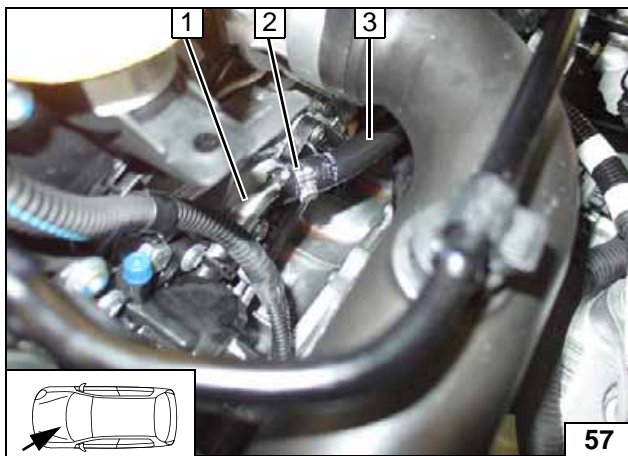

Pull hose to engine outlet / heat exchanger inlet 3 off pipe of engine outlet 1. Remove original vehicle clamp 2 and discard.



Cutting point

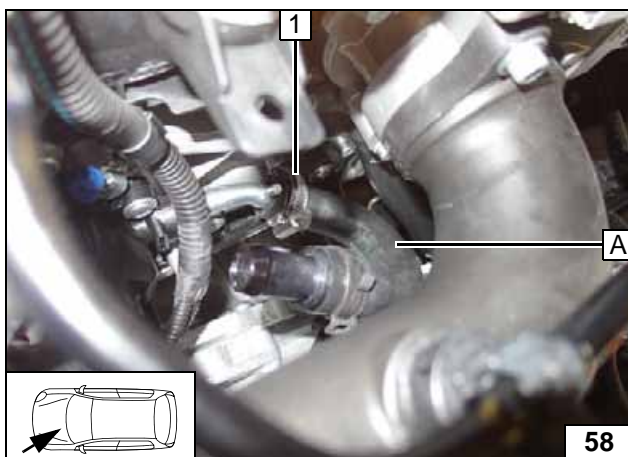

Mount hose A with 15 mm dia. side onto pipe of engine outlet.

- 1 16-27 mm dia. hose clamp



Connection of hose A

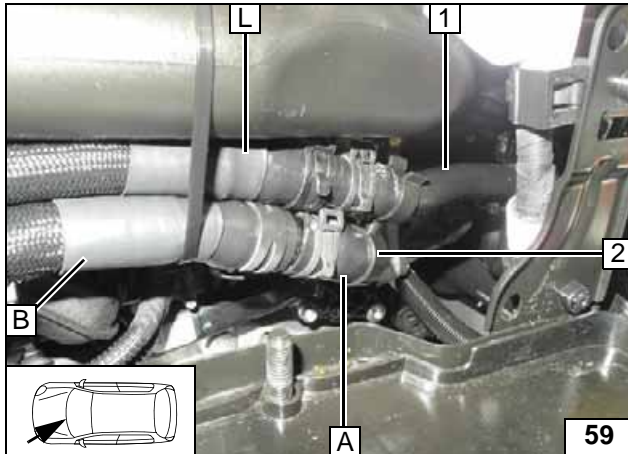

- 1 Hose of heat exchanger inlet
- 2 20-22 mm hose bracket between hose A and hose of heat exchanger inlet

Connecting engine outlet / heat exchanger inlet

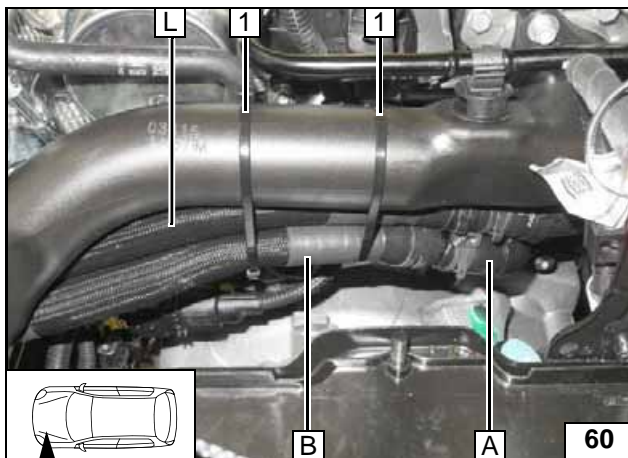

- 1 Cable tie around charge-air tube and hose B and L [2x]

Routing in engine compartment

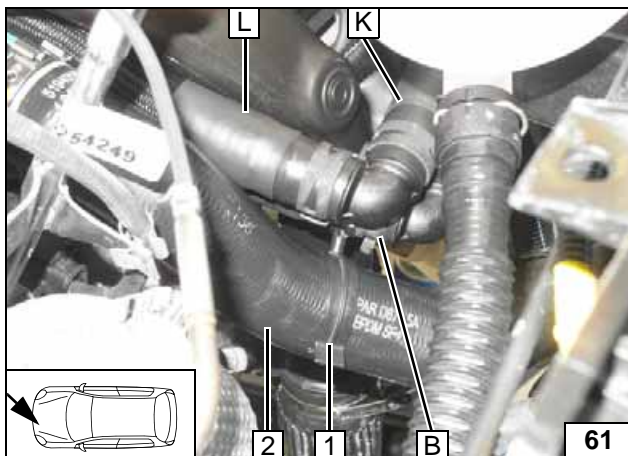

Install 25-37 mm dia. hose bracket 1 between hose B and original vehicle hose 2.



Installing hose bracket

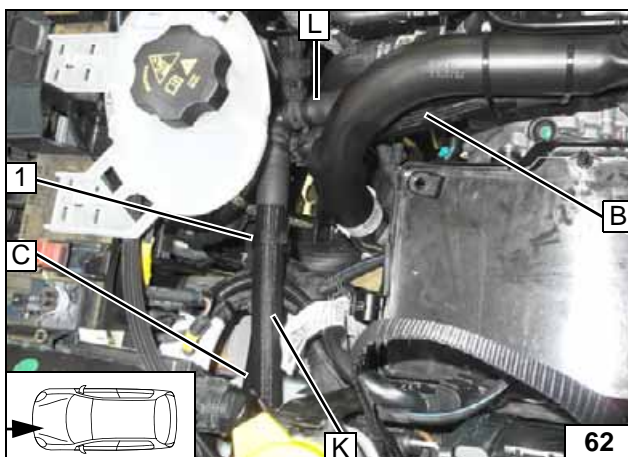

- 1 20-22 mm hose bracket between hose C and K

Routing in engine compartment

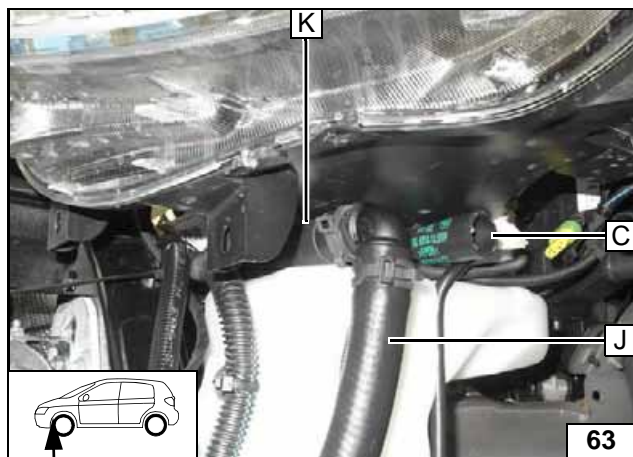

Conne-
ction of hose
J

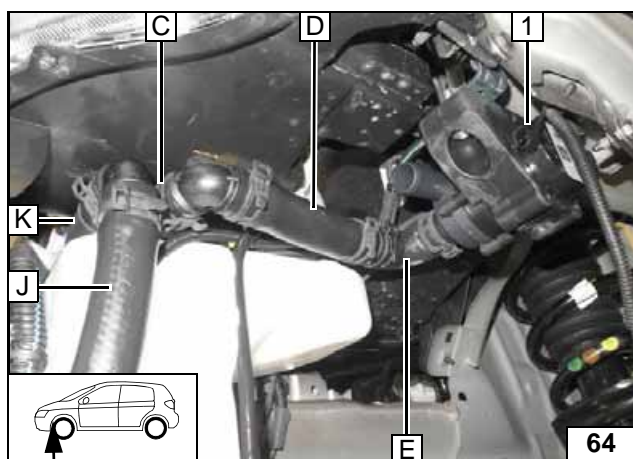

1 Circulating pump

Connect-
ing hoses D
and E

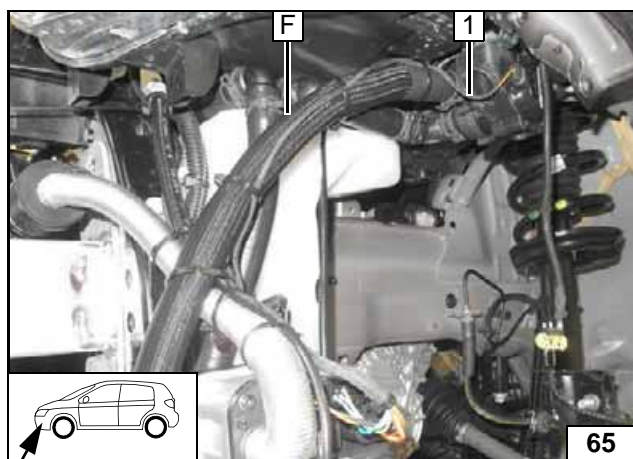

Fill hose F with coolant before installation. Align hoses. Ensure sufficient distance from neighbouring components, correct if necessary.



1 Circulating pump wiring harness with cable tie fastened on hose F

Conne-
ction of hose
F

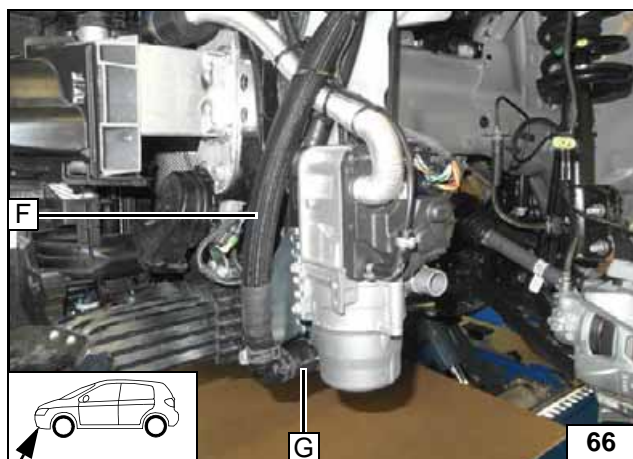

Conne-
ction of hose
F

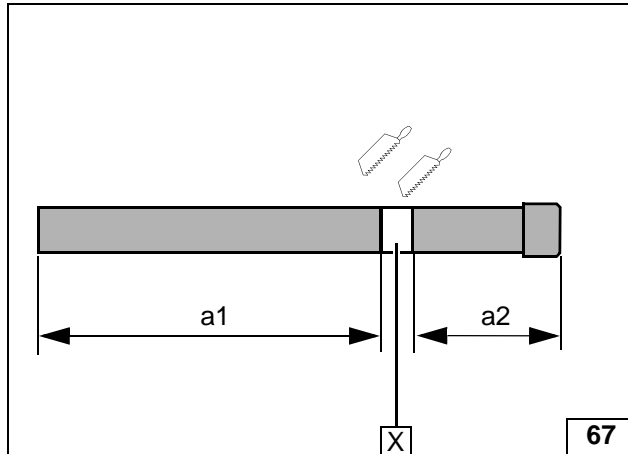
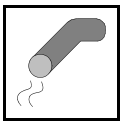

Exhaust Gas

a1 = 590
a2 = 100

X =



Preparing exhaust pipe

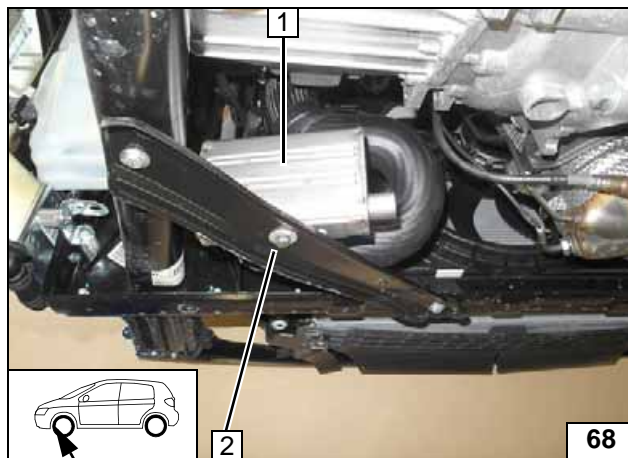

- 1 Silencer
- 2 M6x16 bolt, spring lockwasher, large diameter washer with outer dia. $d_a = 17.4\text{mm}$; original vehicle hole

Installing silencer

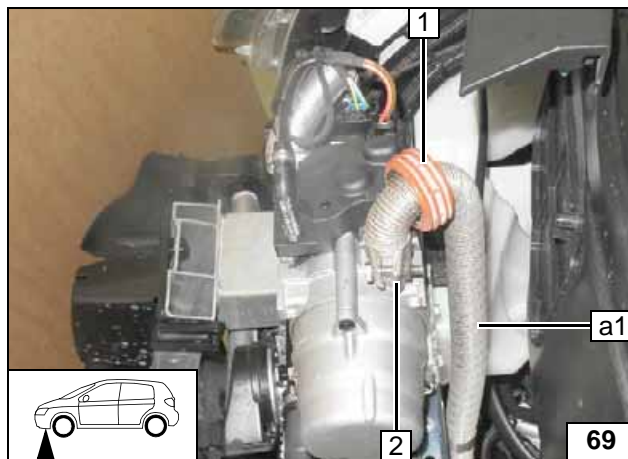

- 1 Spacer bracket
- 2 Hose clamp

Installing exhaust pipe a1

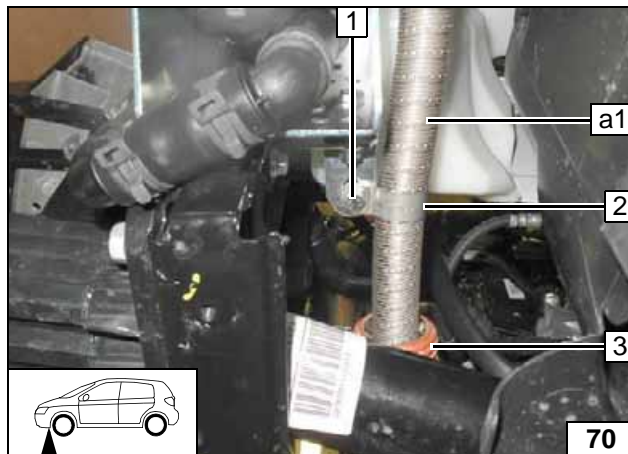

- 1 M6x20 bolt, flanged nut
- 2 Pipe clamp
- 3 Spacer bracket

Installing exhaust pipe a1

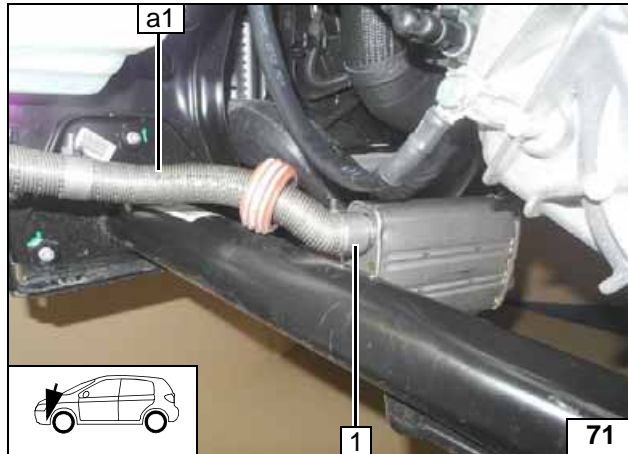
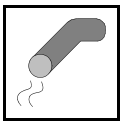

1 Hose clamp

Installing exhaust pipe a1



Exhaust system routing

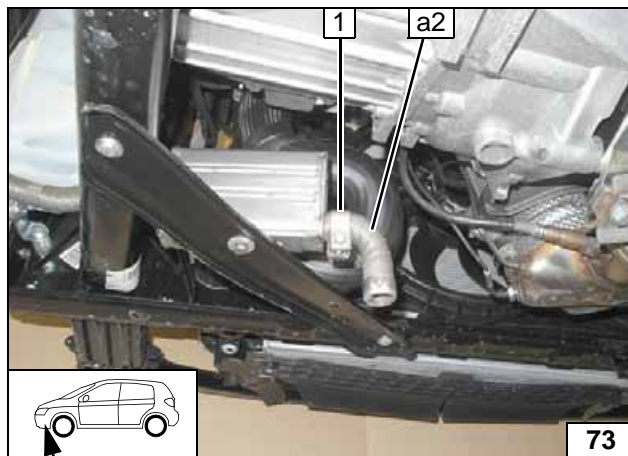

1 Hose clamp



Installing exhaust pipe a2

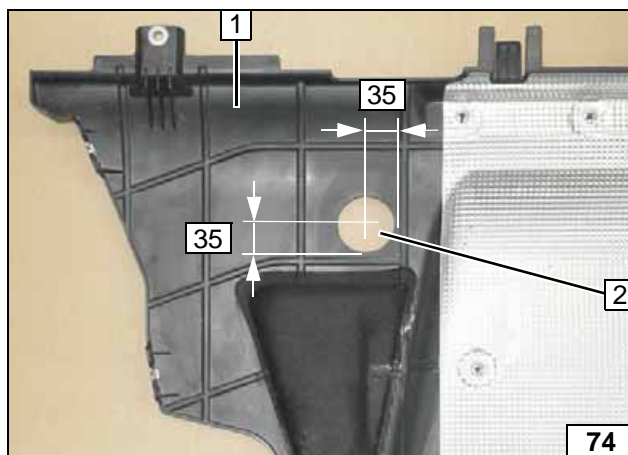

1 Underride protection
2 60 mm dia. hole



Processing underide protection

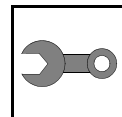

Final Work



Reassemble the components in reverse order. Check all hoses, clamps and all electrical connections for firm seating. Insulate and tie back all loose lines. Only use manufacturer-approved coolant. Spray the heater components with anti-corrosion wax (Tectyl 100K).

- **Connect the battery.**
- **Fill and bleed the coolant circuit according to the vehicle manufacturer's specifications.**
- **Program MultiControl CAR, teach Telearstart transmitter.**
- **Make settings on A/C control panel according to the 'Operating Instructions for End Customer'.**
- **Place the 'Switch off parking heater before refuelling' caution label near the filler neck.**
- **For initial startup and function check, please see installation instructions.**

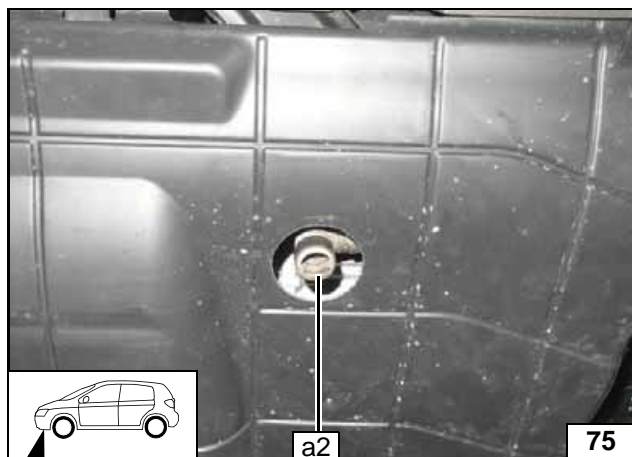

Align exhaust pipe **a2** with the centre of the hole and flush with the underride protection. Ensure sufficient distance from neighbouring components, correct if necessary.



Aligning exhaust pipe a2



Fuel Standpipe Template

Top view

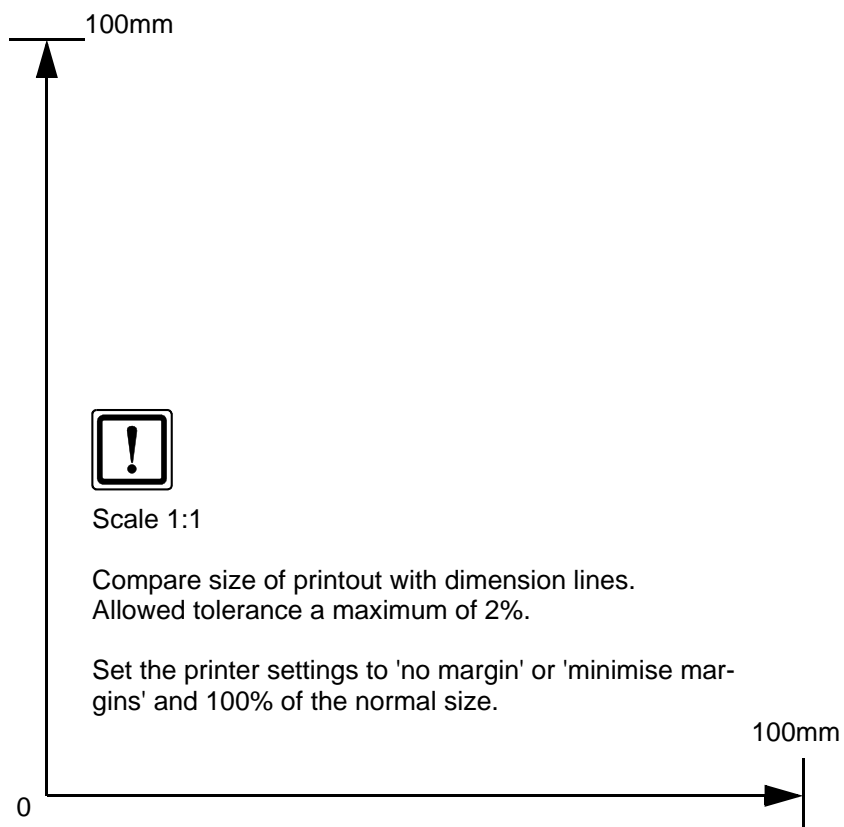
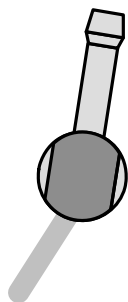

Operating Instructions

Please remove page and add to the vehicle operating instructions.

Note:

We recommend matching the heating time to the driving time.

Heating time = driving time

Example:

For a driving time of approx. 20 min. (in one direction), we recommend not exceeding a switch-on time of 20 min.

Passenger compartment monitoring, if installed, must be deactivated in addition to the vehicle settings for the heating operation.

For instructions on deactivation, please refer to the operating instructions of the vehicle.

Before parking the vehicle, make the following settings:

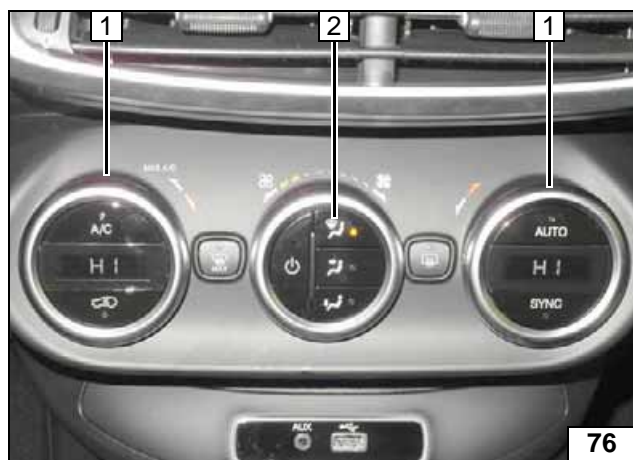

- 1 Set temperature on both sides to 'HI'
- 2 Air outlet to windscreen

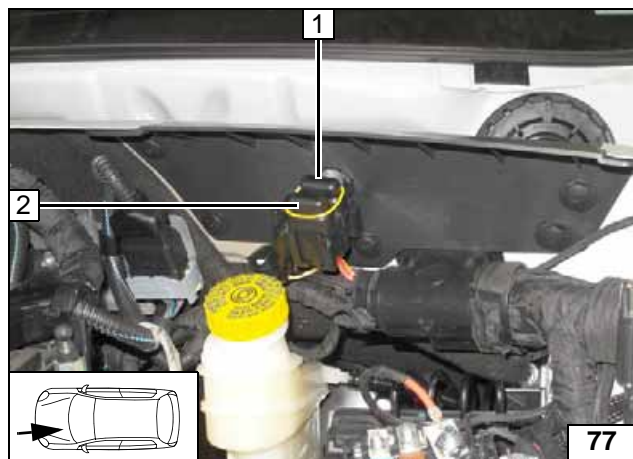

- 1 30A main fuse F2 of passenger compartment
- 2 20A heater fuse F1

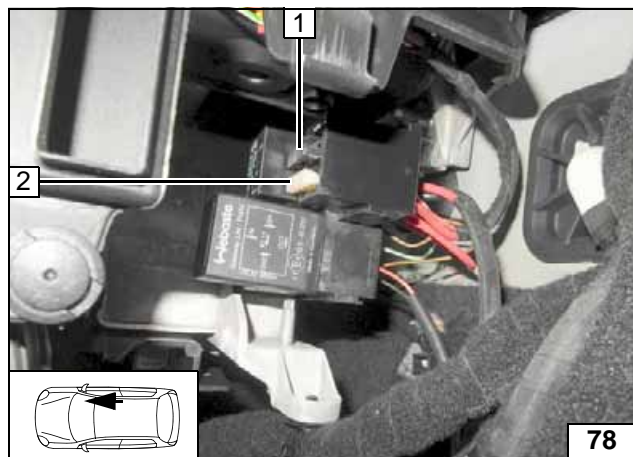

- 1 1A fuse F3 of heater control
- 2 25A fan fuse F4



A/C control panel

Engine compartment fuses

Passenger compartment fuses

