



Water Heater

Thermo Top Evo Parking Heater
'Island based circuit'



With FuelFix

Installation Documentation Citroen C4

Validity

Manufacturer	Model	Type	EG BE No. / ABE
Citroen	C4	NC	e2 * 2007 / 46 * 0040

Motorisation	Fuel	Transmission type	Output in kW	Displacement in cm ³	Engine code
1.2 P Pure Tech 130	Petrol	6-gear SG	96	1199	HN02

SG = manual transmission

From model year 2015
Left-hand drive vehicle

Verified equipment variants: Automatic air-conditioning
Front fog lights
Automatic Start-Stop system
Headlight washer system

Not verified: Manual air-conditioning
Passenger compartment monitoring

Total installation time: approx. 8 hours

Citroen C4

Table of Contents

Validity	1	Preparing Installation Location	15
Necessary Components	2	Preparing Heater	17
Installation Overview	2	Installing Heater	19
Information on Total Installation Time	2	Combustion Air	20
Information on Operating and Installation Instructions	3	Fuel	21
Information on Validity	4	Installing FuelFix	23
Technical Information	4	Coolant Circuit	26
Explanatory Notes on Document	4	Exhaust Gas	31
Preliminary Work	5	Final Work	33
Heater Installation Location	5	FuelFix Template	34
Preparing Electrical System	6	Operating Instructions for Automatic A/C	35
Electrical System	9		
Fan Controller	10		
MultiControl CAR Option	13		
Remote Option (Telestart)	13		
ThermoCall Option	14		

Necessary Components

- Basic delivery scope of Thermo Top Evo in accordance with price list
- Installation kit with FuelFix for Citroen C4 2015 Petrol: **1324342A**
- Heater control in accordance with price list and upon consultation with end customer
- In case of Telestart, indicator lamp in accordance with price list and in consultation with end customer

Installation instructions:

- Arrange for the vehicle to be delivered with the tank only about ¼ full.
- The installation location of the push button in case of Telestart or ThermoCall should be confirmed with the end customer.
- Depending on the space required and the vehicle manufacturer's instructions, we recommend the use of a vehicle battery with a higher electrical capacity.
- Integration in the coolant circuit is based on the island circuit model. In parking heating mode there will be **no** engine pre-heating.

Installation Overview

Legend:

1. Heater
2. Engine compartment fuse holder
3. Passenger compartment relay and fuse holder
4. PWM-Gateway
5. Relay K2
6. Circulating pump
7. MultiControl CAR
8. Metering pump
9. FuelFix

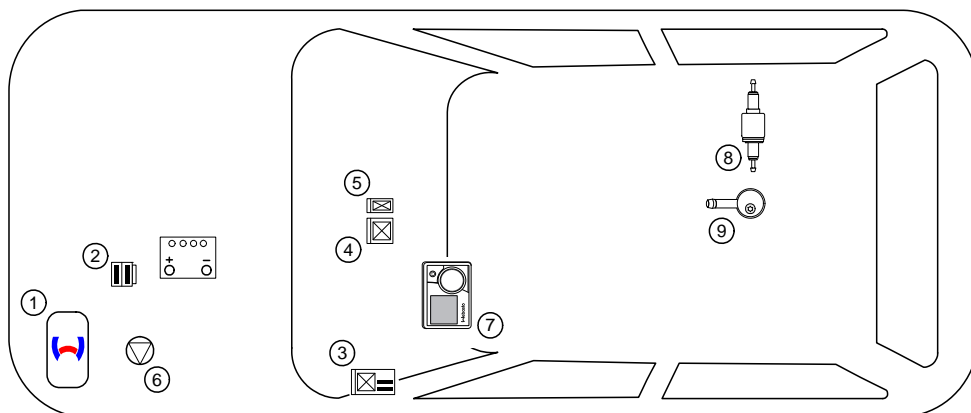

Information on Total Installation Time

The total installation time includes the time needed for mounting and demounting the vehicle-specific components, the heater specific installation time and all other times required for the system integration and initial start-up of the heater. The total installation time may vary for vehicle equipment other than provided.

Information on Operating and Installation Instructions

1 Important information (not complete)

1.1 Installation and repair



The improper installation or repair of Webasto heating and cooling systems can cause fire or the leakage of deadly carbon monoxide, leading to serious injury or death.



To install and repair Webasto heating and cooling systems you need to have completed a special company training course and have the appropriate technical documentation, special tools and special equipment.



Installation and repair may ONLY be carried out by persons trained and certified in a Webasto training course. NEVER try to install or repair Webasto heating or cooling systems if you have not completed a Webasto training course, you do not have the necessary technical skills and you do not have the technical documentation, tools and equipment available to ensure that you can complete the installation and repair work properly.

Only use genuine Webasto parts. See the Webasto air and water heaters accessories catalogue for this purpose.

1.2 Operation

To ensure safe operation, we recommend having the heater checked every two years by an authorised Webasto dealer, especially when used over a long period and/or under extreme environmental conditions.

Do not operate the heater in closed rooms due to the danger of poisoning and suffocation.

Always switch off the heater before refuelling.

The heater may only be used with the prescribed fuel diesel (DIN EN 590) or petrol (DIN EN 228).

The heater may not be cleaned with a high-pressure cleaner.

1.3 Please note

ALWAYS follow all Webasto installation and operating instructions and observe all warnings.

To become familiar with and understand all functions and properties of the heater, the operating instructions must be read carefully and observed at all times.

For proper, safe installation and repair work, the installation instructions with all warnings and safety information must be carefully read and observed at all times. Please always contact a workshop authorised by Webasto for all installation and repair work.

Important

Webasto shall assume no liability for defects, damage and injuries resulting from a failure to observe the installation, repair and operating instructions of the information contained in them.

This liability exclusion particularly applies to improper installations and repairs, installations and repairs by untrained persons or in the case of a failure to use genuine spare parts.

The liability due to culpable disregard to life, limb or health and due to damage or injuries caused by a wilful or reckless breach of duty remain unaffected, as does the obligatory product liability.

Installation should be carried out according to the general, standard rules of technology. Unless specified otherwise, fasten hoses, lines and wiring harnesses to original vehicle lines and wiring harnesses using cable ties. Insulate loose wire ends and tie back. Connectors on electronic components must audibly snap into place during assembly.

Sharp edges should be fitted with rub protection. Spray unfinished body areas, e.g. drilled holes, with anti-corrosion wax (Tectyl 100K).

Observe the instructions and guidelines of the respective vehicle manufacturer for demounting and mounting vehicle specific components!

The initial startup is to be executed with the Webasto Thermo Test Diagnosis.

When installing a programmable control module (e.g. a PWM Gateway), the corresponding settings must be checked or adjusted.

2 Statutory regulations governing installation

Guidelines	Thermo Top Evo
Heating Directive ECE R122	E1 00 0258
EMC Directive ECE R10	E1 04 5627

Note

The regulations of these guidelines are binding in the scope of the Directive 70/156/EEC and/or 2007/46/EC (for new vehicle models from 29/04/2009) and should also be observed in countries in which there are no special regulations.

Important

Failure to follow the installation instructions will result in the invalidation of the type approval for the heater and therefore invalidation of the general **homologation of the vehicle**.

Note

The heater is licensed in accordance with paragraph 19, section 3, No. 2b of the StVZO (German Road Traffic Licensing Authority).

2.1 Excerpt from ECE regulation 122 (heating system) paragraph 5 for the installation of the heater

Beginning of excerpt.

ANNEX VII

REQUIREMENTS FOR COMBUSTION HEATERS AND THEIR INSTALLATION

1. GENERAL REQUIREMENTS

1.7.1. A clearly visible tell-tale in the operator's field of view shall inform when the combustion heater is switched on or off.

2. VEHICLE INSTALLATION REQUIREMENTS

2.1. Scope

2.1.1. Subject to paragraph 2.1.2, combustion heaters shall be installed according to the requirements of this Annex.

2.1.2. Vehicles of category O having liquid fuel heaters are deemed to comply with the requirements of this Annex.

2.2. Positioning of heater

2.2.1. Body sections and any other components in the vicinity of the heater must be protected from excessive heat and the possibility of fuel or oil contamination.

2.2.2. The combustion heater shall not constitute a risk of fire, even in the case of overheating. This requirement shall be deemed to be fulfilled if the installation ensures an adequate distance to all parts and suitable ventilation, by the use of fire resistant materials or by the use of heat shields.

2.2.3. In the case of M2 and M3 vehicles, the heater must not be positioned in the passenger compartment. However, an installation in an effectively sealed envelope which also complies with the conditions in paragraph 2.2.2 may be used.

2.2.4. The label referred to in paragraph 1.4 or a duplicate, must be positioned so that it can be easily read when the heater is installed in the vehicle.

2.2.5. Every reasonable precaution should be taken in positioning the heater to minimise the risk of injury and damage to personal property.

2.3. Fuel supply

2.3.1. The fuel filler must not be situated in the passenger compartment and must be provided with an effective cap to prevent fuel spillage.

2.3.2. In the case of liquid fuel heaters, where a supply separate to that of the vehicle is provided, the type of fuel and its filler point must be clearly labelled.

2.3.3. A notice, indicating that the heater must be shut down before refuelling, must be affixed to the fuelling point. In addition a suitable instruction must be included in the manufacturer's operating manual.

2.4. Exhaust system

2.4.1. The exhaust outlet must be located so as to prevent emissions from entering the vehicle through ventilators, heated air inlets or opening windows.

2.5. Combustion air inlet

2.5.1. The air for the combustion chamber of the heater must not be drawn from the passenger compartment of the vehicle.

2.5.2. The air inlet must be so positioned or guarded that blocking by rubbish or luggage is unlikely.

2.6. Heating air inlet

2.6.1. The heating air supply may be fresh or recirculated air and must be drawn from a clean area not likely to be contaminated by exhaust fumes emitted either by the propulsion engine, the combustion heater or any other vehicle source.

2.6.2. The inlet duct must be protected by mesh or other suitable means.

2.7. Heating air outlet

2.7.1. Any ducting used to route the hot air through the vehicle must be so positioned or protected that no injury or damage could be caused if it were to be touched.

2.7.2. The air outlet must be so positioned or guarded that blocking by rubbish or luggage is unlikely.

End of excerpt.

In multilingual versions the German language is binding.

Citroen C4

Information on Validity

This installation documentation applies to Citroen C4 Petrol vehicles - for validity, see page 1 - from model year 2015 and later, assuming technical modifications to the vehicle do not affect installation, any liability claims excluded. Depending on the vehicle version and equipment, modifications may be necessary during installation with respect to this 'installation documentation'.

Vehicle and engine types, equipment variants and other specifications not listed in this installation documentation have not been tested. However, installation according to this installation documentation may be possible.

Technical Information

Special Tools

- Hose clamp pliers for auto-tightening hose clamps
- Hose clamp pliers for Clic hose clamps of type W
- Automatic wire stripper 0.2 - 6mm²
- Crimping pliers for cable lug / tab connector 0.5 - 6mm²
- Torque wrench for 2.0 - 10 Nm
- Hose clamping pliers
- Metric thread-setter kit
- Deep-hole marker
- Webasto Thermo Test Diagnosis with current software

Dimensions

- All dimensions are in mm.

Tightening torque values

- Tightening torque values of 5x13 heater bolts and 5x11 heater stud bolts = 8Nm.
- Tightening torque value of 5x15 water connection piece retaining plate bolt = 7Nm.
- Tighten other bolt connections in accordance with manufacturer's instructions or in accordance with state-of-the-art technology.

Explanatory Notes on Document

You will find an identification mark on the outside top right corner of the page in question to provide you with a quick overview of the individual working steps.

Special features are highlighted using the following symbols:

Mechanical System



Electrical System



Coolant Circuit



Combustion Air



Fuel



Exhaust Gas



Software



Specific risk of damage to components.



Specific risk due to electrical voltage.



Specific risk of injury or fatal accidents.



Specific risk of fire or explosion.



Reference to the manufacturer's vehicle-specific documents or to the general installation instructions of Webasto components.



Reference to a special technical feature.



The arrow in the vehicle icon indicates the position on the vehicle and the viewing angle.



Tightening torque according to the manufacturer's vehicle-specific documents.



Preliminary Work

Vehicle



- Open the fuel tank cap.
- Ventilate the fuel tank.
- Close the fuel tank cap again.
- Depressurise the cooling system.
- Remove the underride protection.
- Remove the right lower fuel tank cover.
- Detach the left-hand wheel well trim (for battery carrier bolts).
- Completely remove the battery together with the carrier.
- Remove the air filter completely, together with the intake hose.
- Remove the bracket of the air filter.
- Remove the windscreen wipers.
- Remove the coolant reservoir cap.
- Remove the rear bench seat. Remove the middle air nozzle in the instrument panel.
- Remove the multifunction display frame.
- Remove the multifunction display.
- Remove the A/C control panel in accordance with the manufacturer's instructions.
- Remove the radio with shaft.
- Remove the lower and left instrument panel trim on the driver's side.
- Remove the OBD socket cover.

Heater

- Remove years that do not apply from the type and duplicate label.
- Attach the duplicate label (type label) visibly in the appropriate place in the engine compartment.



Heater Installation Location

- 1 Heater

Installation location

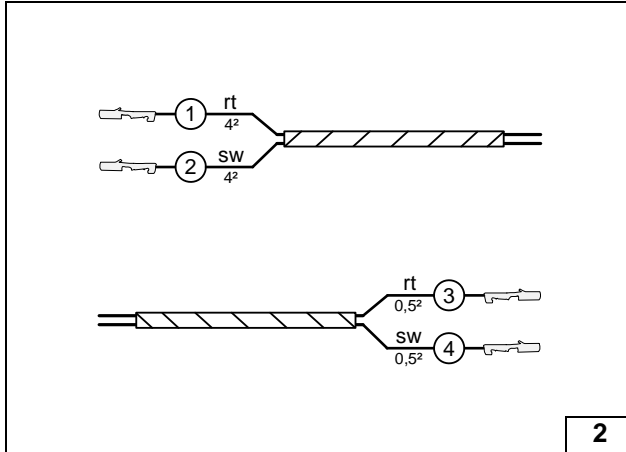

Preparing Electrical System

Wire sections retain their numbering in the entire document.

Produce all following electrical connections as shown in the wiring diagram.

- ① Red (rt) wire of fan wiring harness
- ② Black (sw) wire of fan wiring harness
- ③ Red (rt) wire from wiring harness of PWM control
- ④ Black (sw) wire from wiring harness of PWM control



Cutting to length / assigning wires

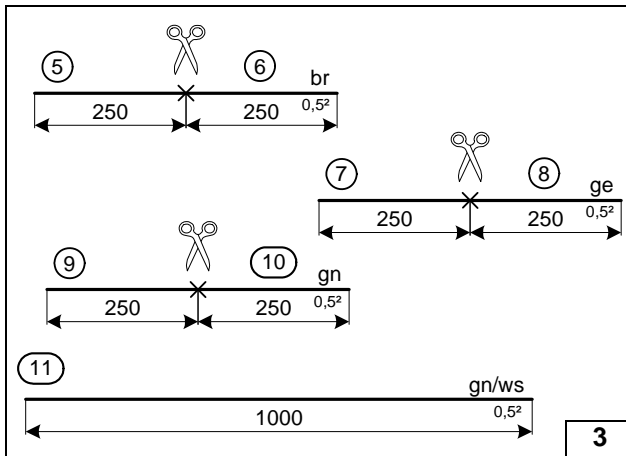

Cutting to length / assigning wires

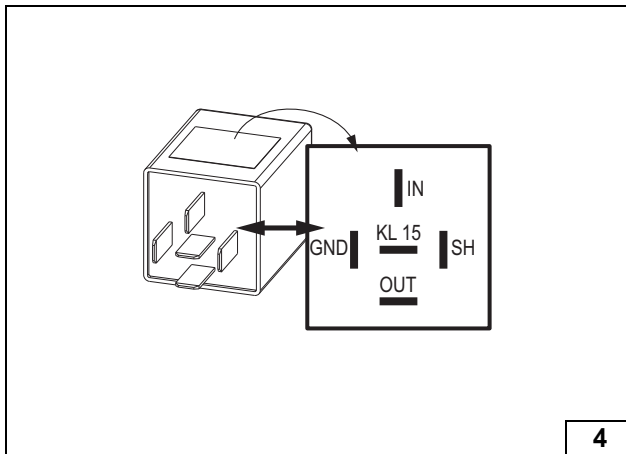

Check the PWM Gateway settings when starting up the heater and adjust if necessary.

Settings:

- Duty cycle: 70%
- Frequency: 400
- Voltage: not relevant
- Function: Low side



View of PWM GW

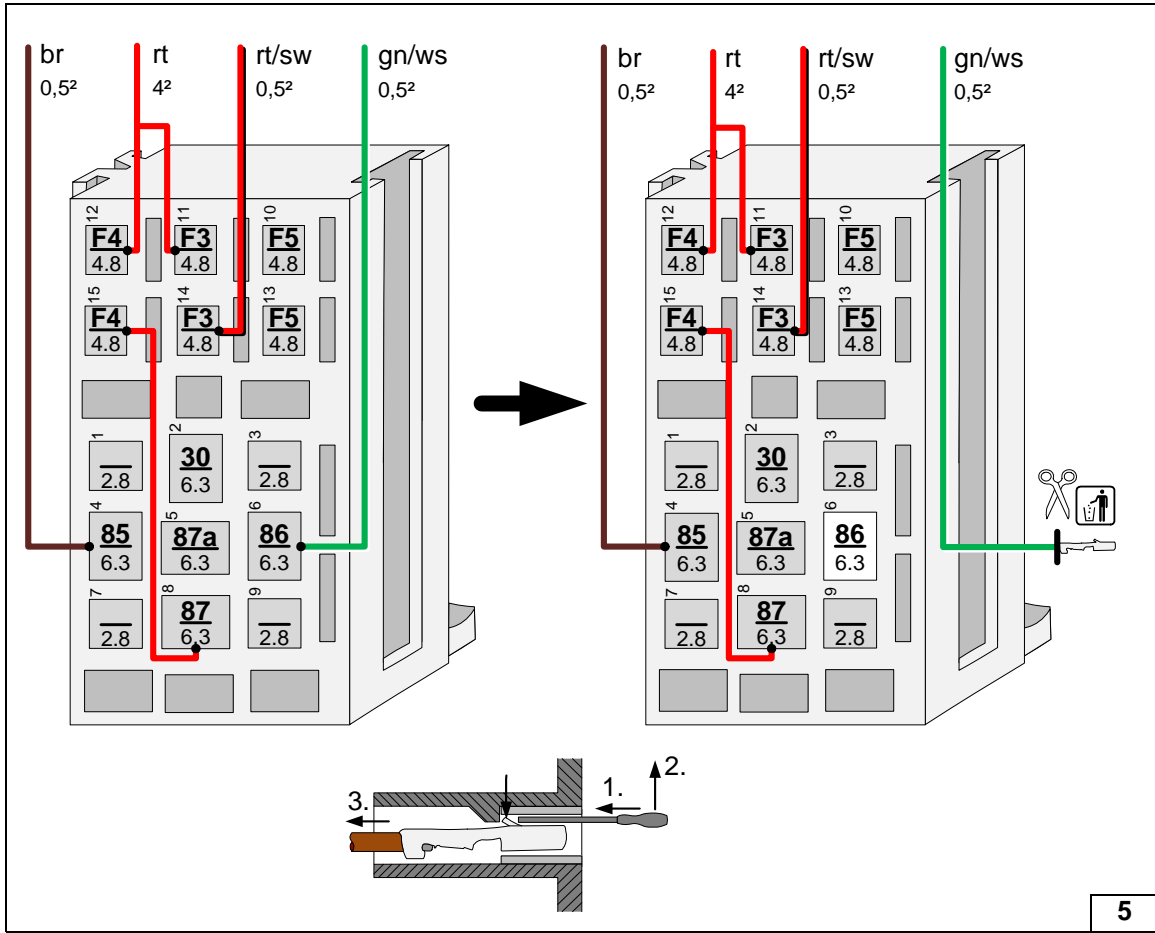

Preparing passenger compartment relay and fuse holder

5

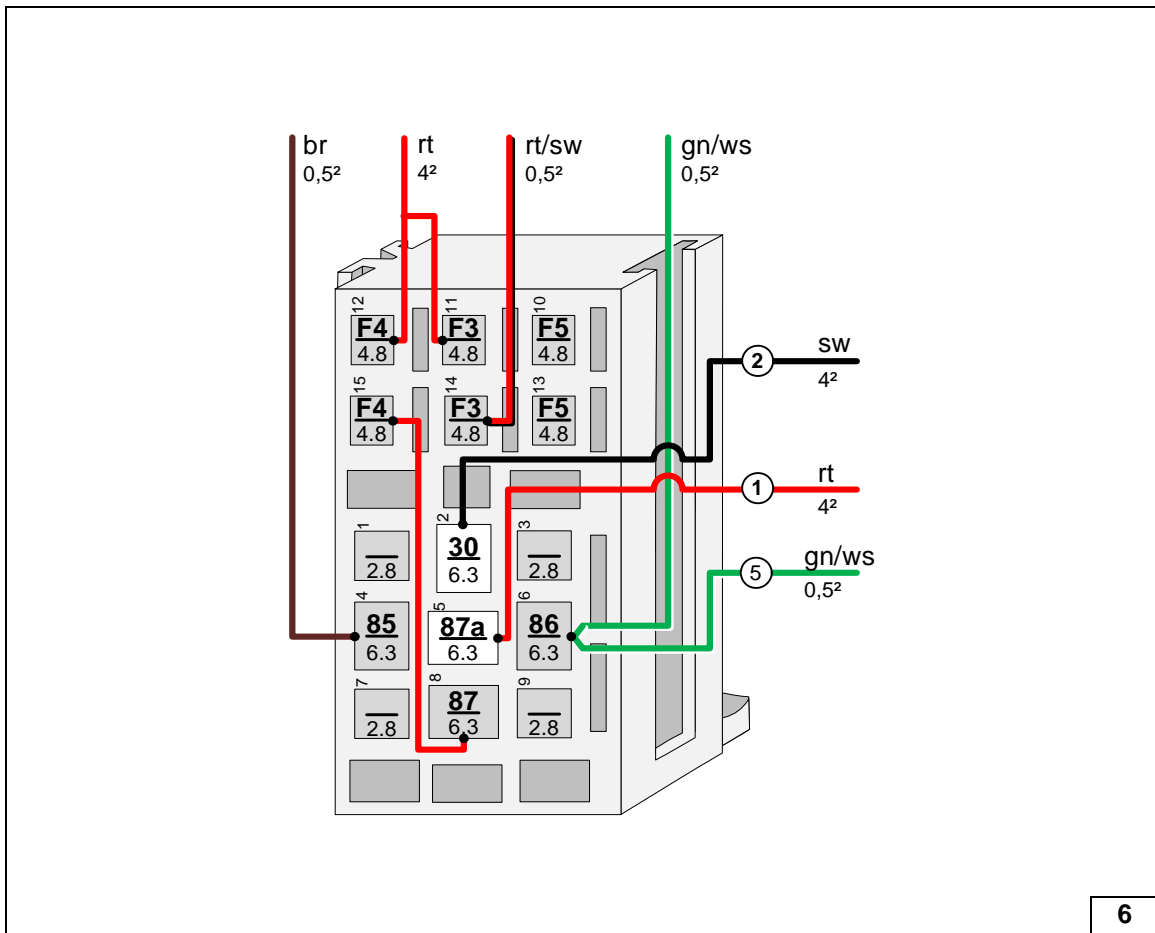

Connecting wires to passenger compartment relay and fuse holder

6

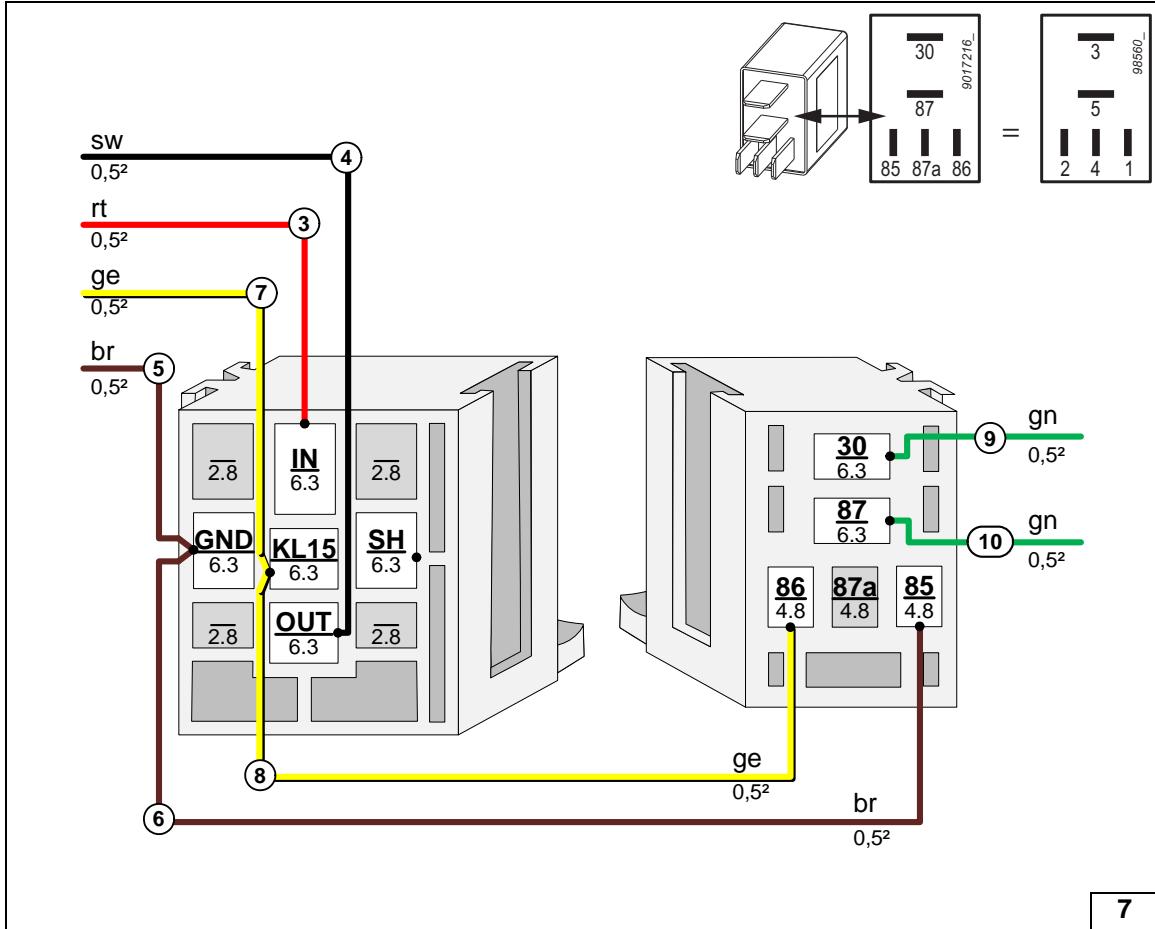

Connecting wires to socket of relay K2 and to PWM GW

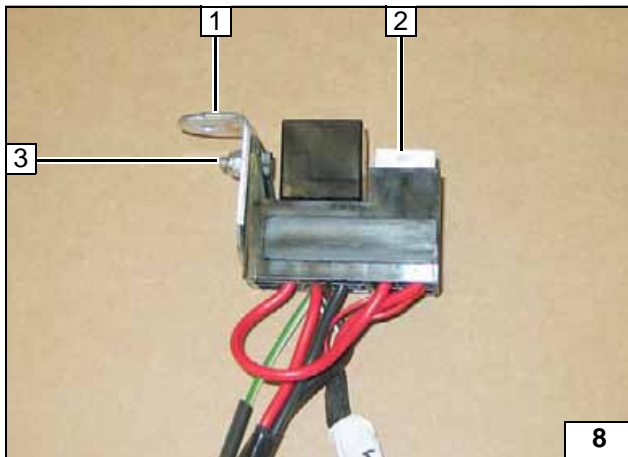

- 1 Angle bracket
- 2 25A fuse F4
- 3 M5x16 bolt, large diameter washer [2x], nut

Installing angle bracket



Electrical System



Earth wire

- 1 Earth wire on original vehicle earth support point

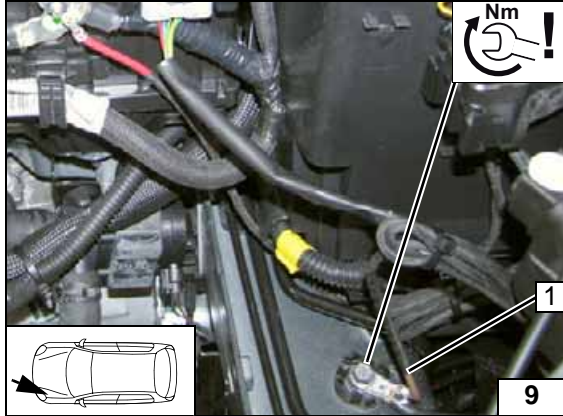

Positive wire

- 1 Positive wire on positive battery distributor

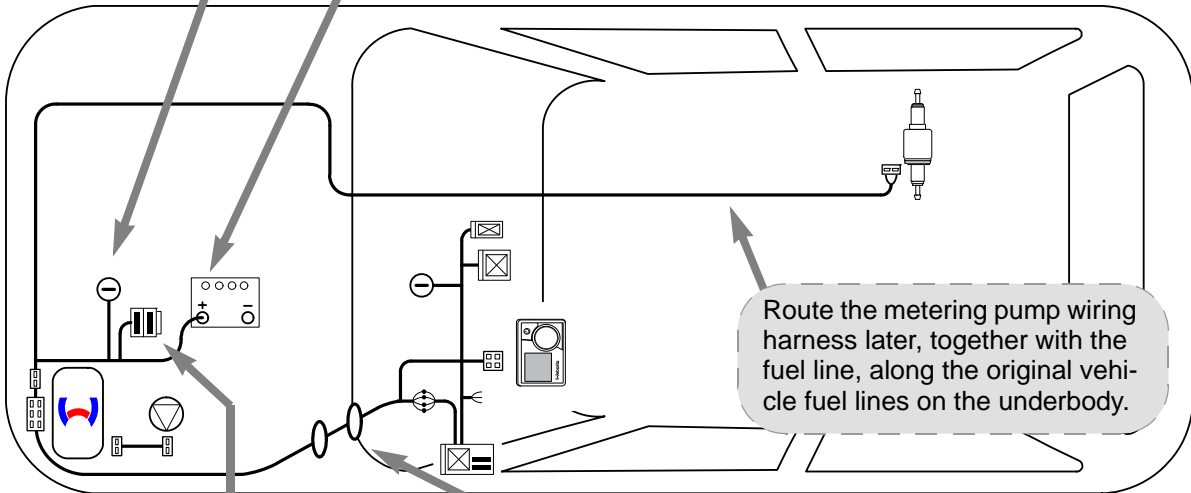
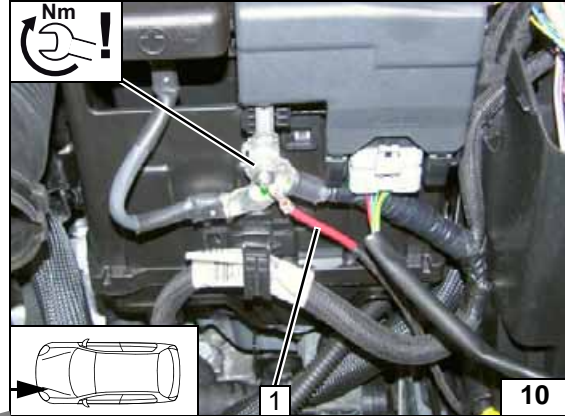

Wiring harness routing diagram

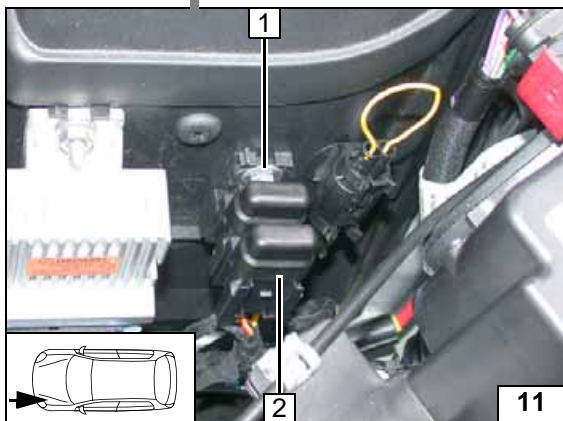

Engine compartment fuse holder

- 1 5.5 mm dia. hole; M5x16 bolt, washer [2x], retaining plate of fuse holder, nut
- 2 Fuses F1-2

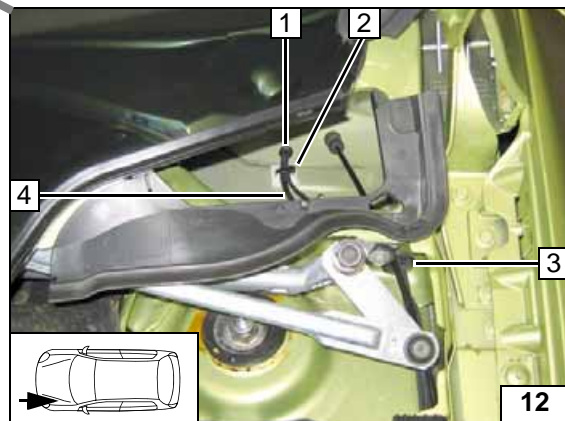

Wiring harness pass through

- 1 Protective rubber plug
- 2 Adhesive base with cable tie
- 3 Protective rubber plug
- 4 Wiring harnesses of heater, heater controls

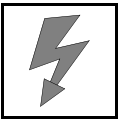

Fan Controller

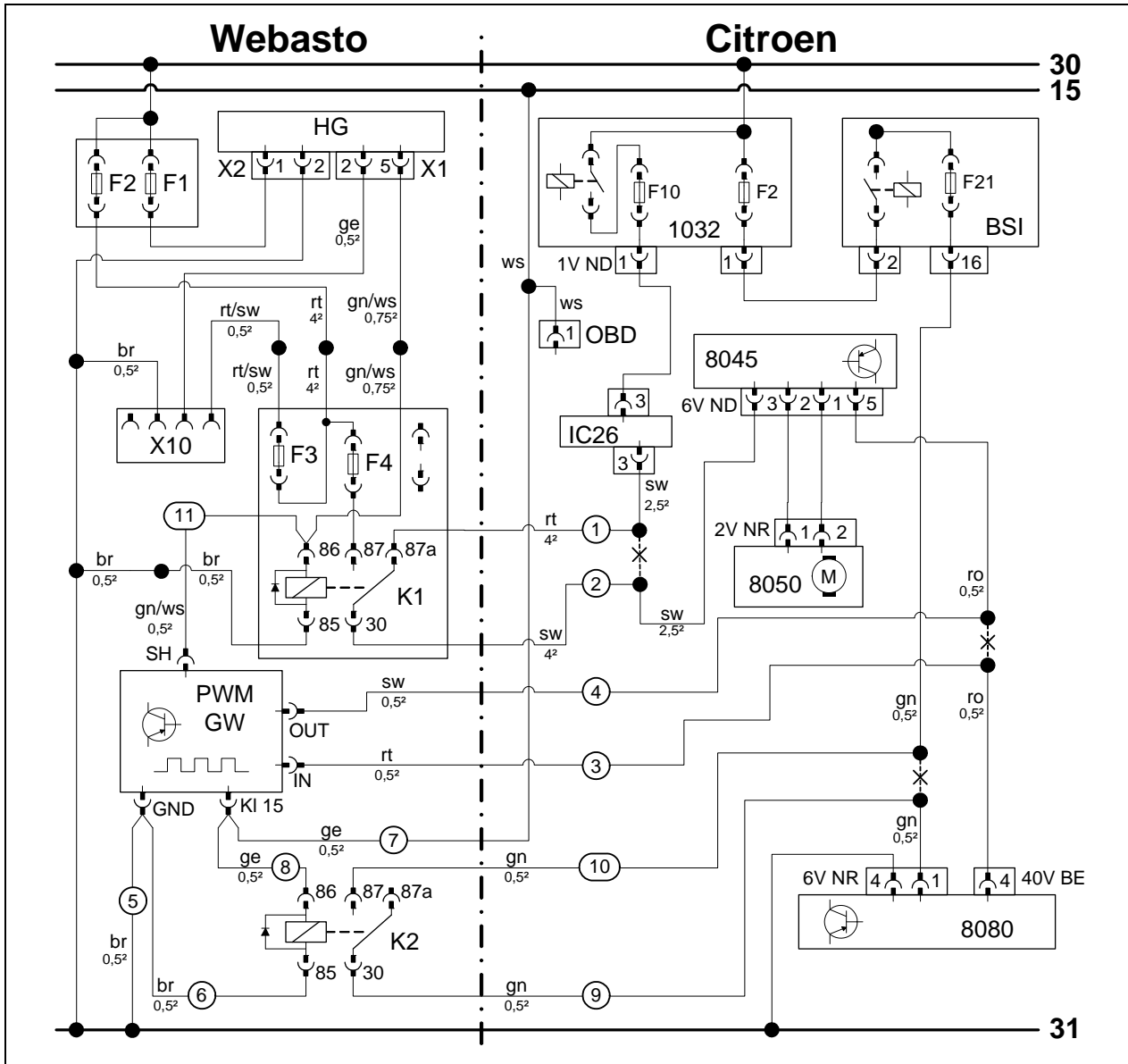

Wiring diagram

Webasto components		Vehicle components		Colours and symbols	
HG	TT-Evo heater	1032	Main power supply	rt	red
X1	6-pin heater connector	F10	Fuse	sw	black
X2	2-pin heater connector	F2	Fuse	ge	yellow
F1	20A fuse	1V ND	Connector 1032	gn	green
F2	30A fuse	BSI	Central electrical box for passenger compartment	ws	white
X10	4-pin connector of heater control	F21	Fuse	br	brown
F3	1A fuse	OBD	OBD connector	gn/ws	green/white
F4	25A fuse	8045	Fan controller	rt/sw	red/black
K1	Fan relay	6V ND	6-pin connector 8045	ro	pink
PWM GW	PWM Gateway	IC26	6-pin connector		
K2	Additional relay	2V NR	2-pin connector 8050		
PWM GW settings:		8050	Fan motor		
Duty cycle:	70%	6V NR	6-pin connector 8080		
Frequency:	400Hz	40V BE	40-pin connector 8080		
Voltage:	not relevant	8080	A/C control unit		
Function:	Low side			X	Cutting point
				Wiring colours may vary.	

Legend

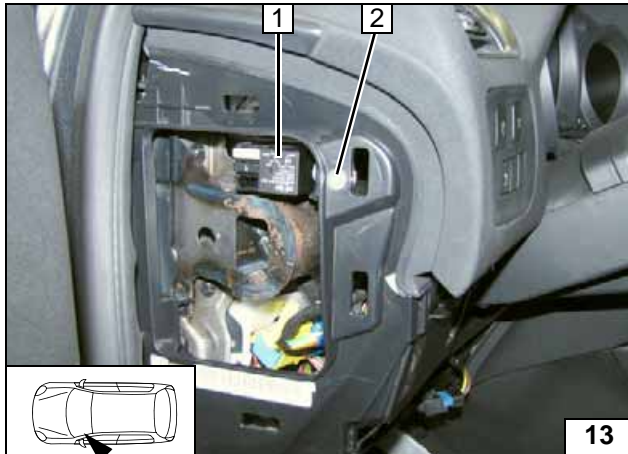

Countersink 6.5 mm dia. hole at position 2.



- 1 Passenger compartment relay and fuse holder
- 2 M6x12 countersunk head screw, large diameter washer, flanged nut

Installing passenger compartment relay and fuse holder

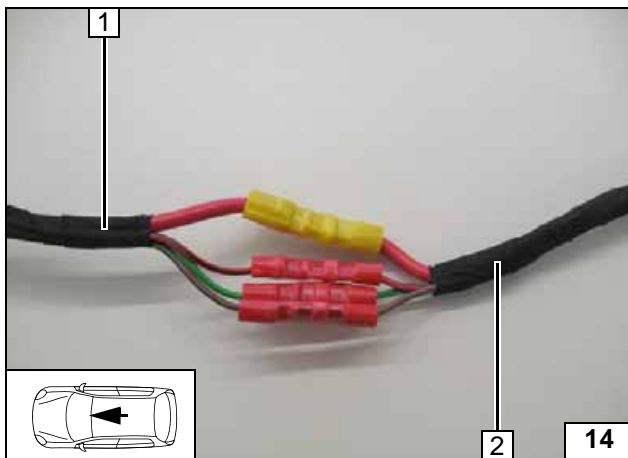

- 1 Passenger compartment relay and fuse holder wiring harness
- 2 Heater wiring harness

Connecting same colour wires of wiring harnesses

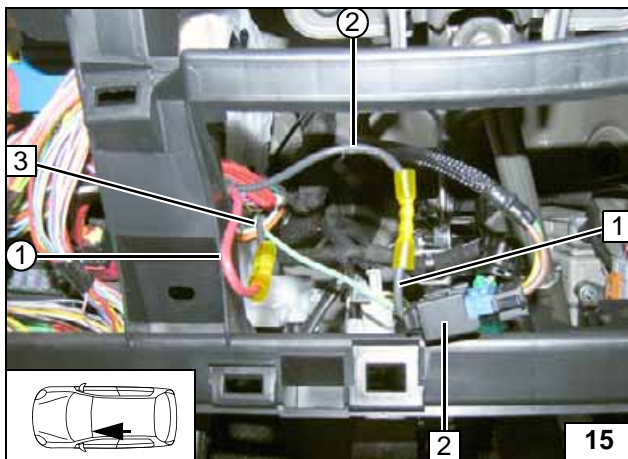

Connection on 6-pin connector 2.



- 1 Black (sw) wire of 6-pin connector
- 3 Black (sw) wire of fuse F10
- ① Red (rt) wire of K1/87a, fan wiring harness
- ② Black (sw) wire of K1/30, fan wiring harness

Connection of connector

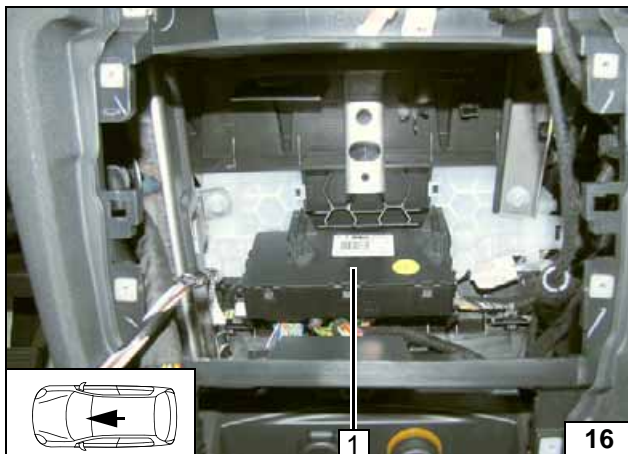

Pull off A/C control unit 1.



Detaching A/C control unit

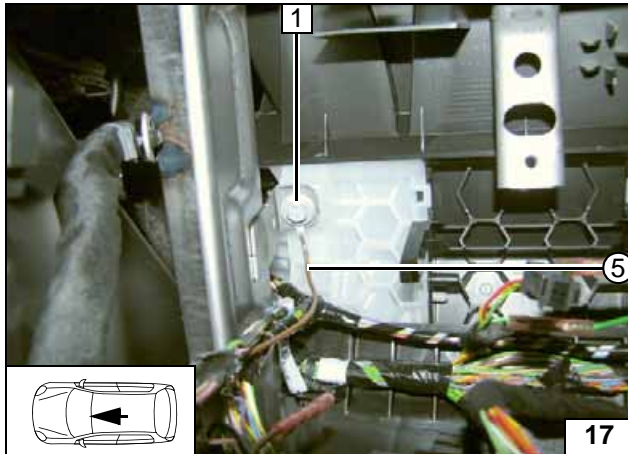

- 1 Original vehicle bolt
- ⑤ Brown (br) wire of PWM GW

**PWM GW
earth con-
nection**

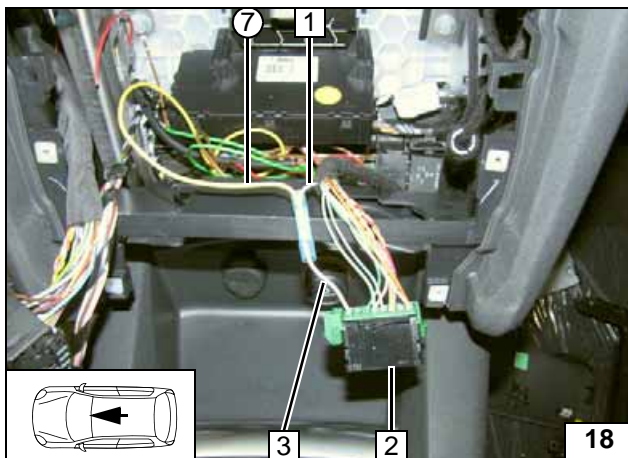

Connection to OBD socket outlet 2.

- 1 White (ws) wire of Terminal 15
- 3 White (ws) wire of OBD socket outlet, pin 1
- ⑦ Yellow (ge) wire of PWM GW/KL15

**Connect-
ing terminal
15**

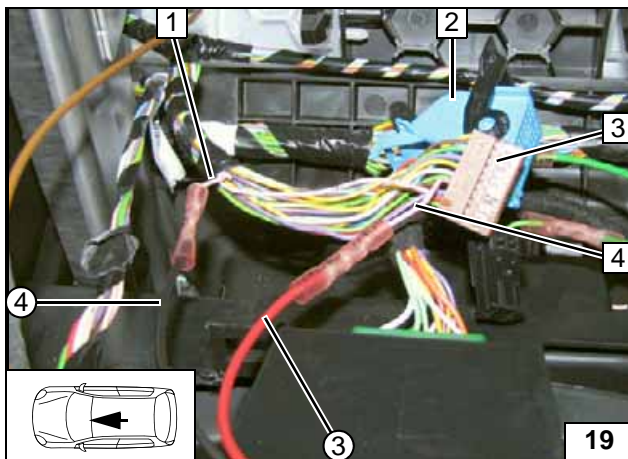

Connection to A/C control unit.
Detach brown (br) connector half 3 (20-pin, pin1-20) from connector 40V BE 2 of A/C control unit.

- 1 Pink (ro) wire of fan controller, Pin 5
- 4 Pink (ro) wire of brown (br) connector, pin 4
- ③ Red (rt) wire from wiring harness of PWM control
- ④ Black (sw) wire from wiring harness of PWM control

**Connecting
A/C control
unit**

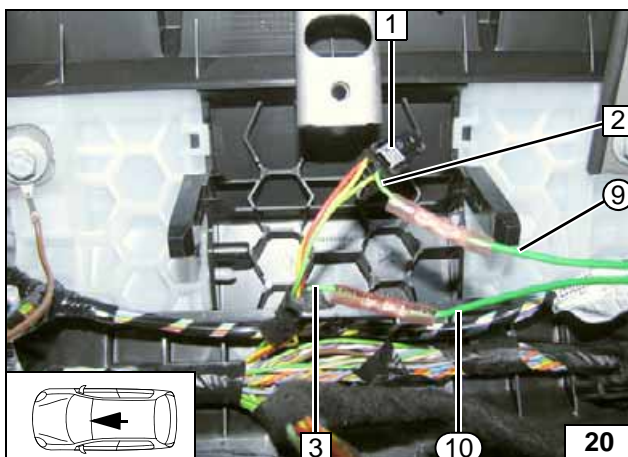

Connection to 6-pin connector 6V NR 1 from A/C control unit.

- 2 Green (gn) wire of 6-pin connector, pin 1
- 3 Green (gn) wire of fuse F21
- ⑨ Green (gn) wire of K2/30
- ⑩ Green (gn) wire of K2/87

**Connecting
A/C control
unit**

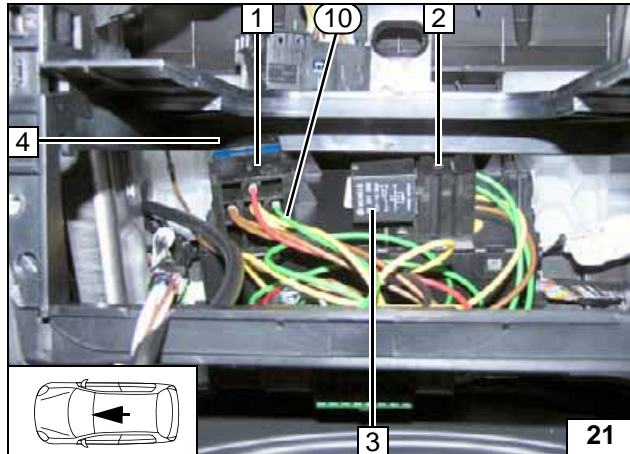
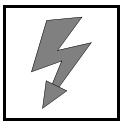

Install radio duct.
Mount A/C control unit.
Connect green/white (gn/ws) wire (10) to PWM GW/SH socket.
Fasten PWM GW socket 1 and relay K2 socket 2 with adhesive tape on A/C control unit.

- 3 Relay K2
- 4 PWM GW



Installing PWM GW and relay K2

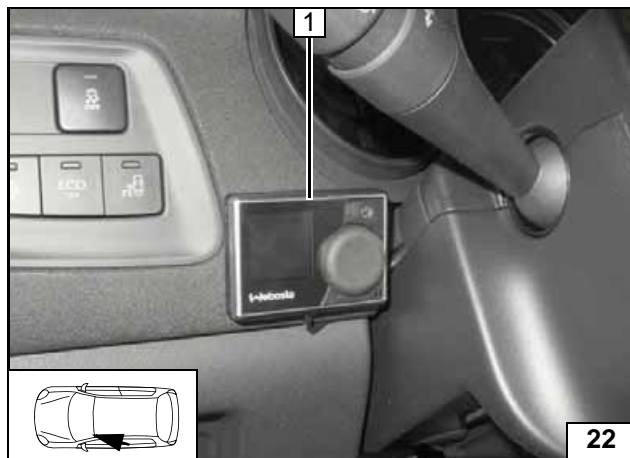

MultiControl CAR Option

- 1 MultiControl CAR



Installing MultiControl CAR

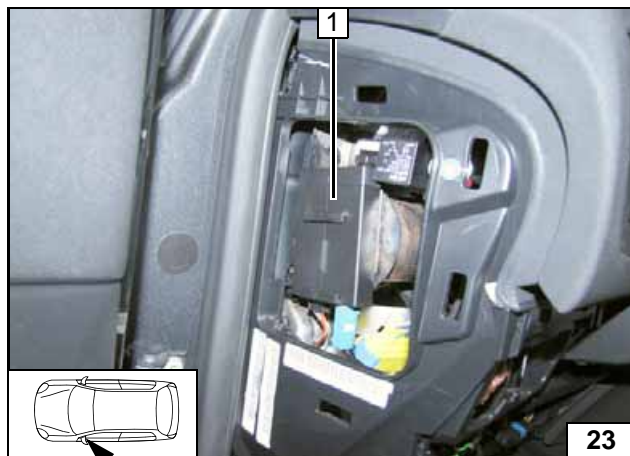

Remote Option (Telestart)

Fasten receiver 1 with double-sided adhesive tape.



Installing receiver

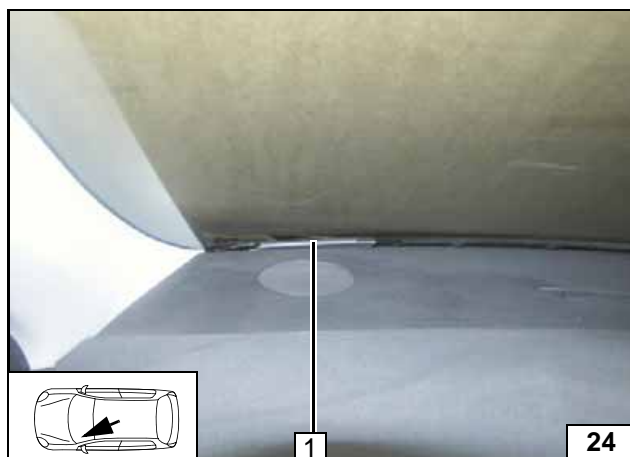

- 1 Aerial

Installing aerial

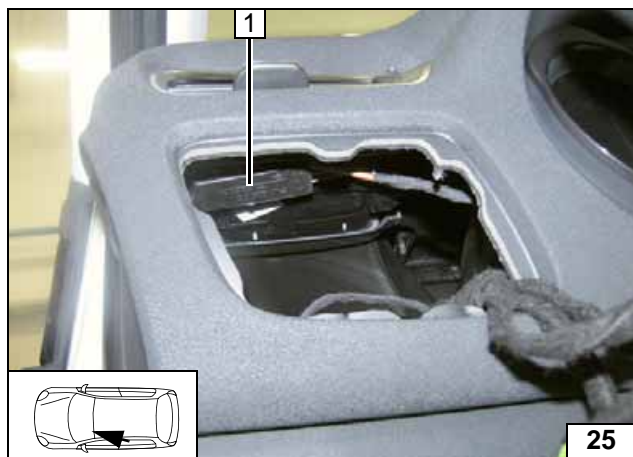

Temperature sensor T100 HTM

Fasten temperature sensor 1 with double-sided adhesive tape.



Installing temperature sensor

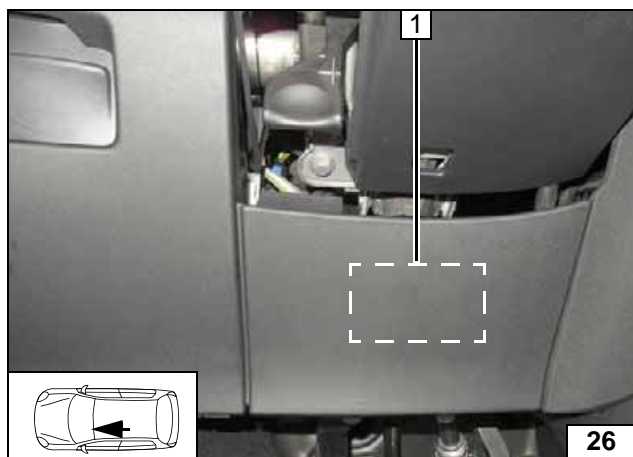

ThermoCall Option

Fasten receiver 1 with double-sided adhesive tape from behind.



Installing receiver

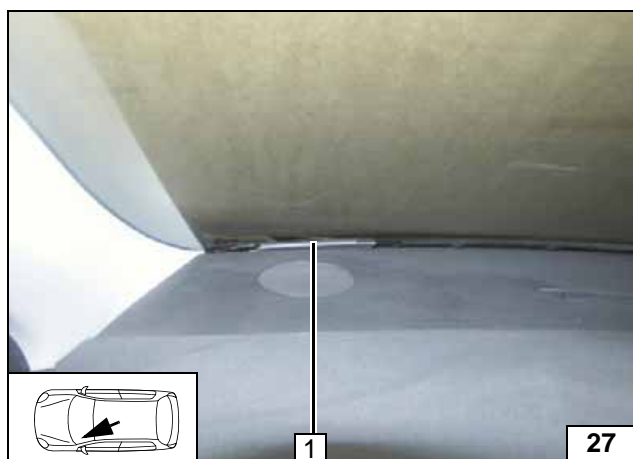

1 Aerial (optional)

Installing aerial

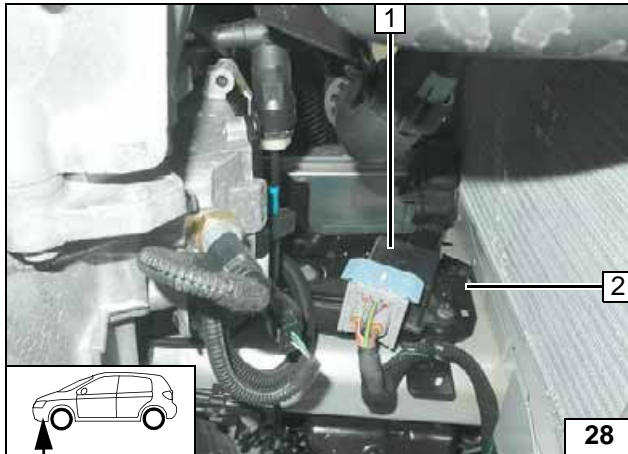
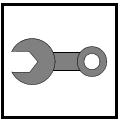

Preparing Installation Location

- 1 Remove relay
- 2 Remove original vehicle bracket

Removing original vehicle relay and bracket

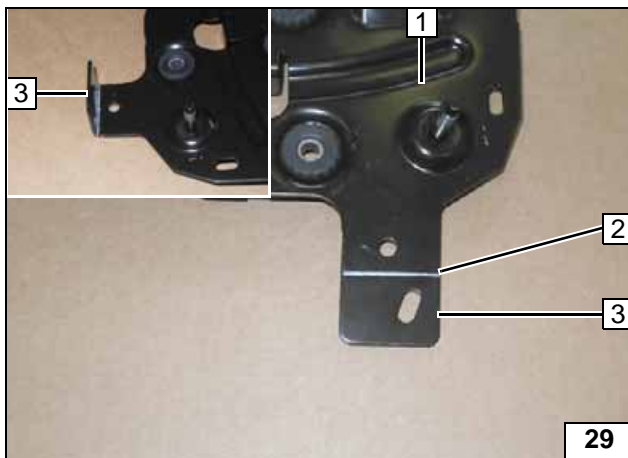

Bend tab 3 of original vehicle bracket 1 by 90° upwards at bending line 2 .



Preparing original vehicle bracket

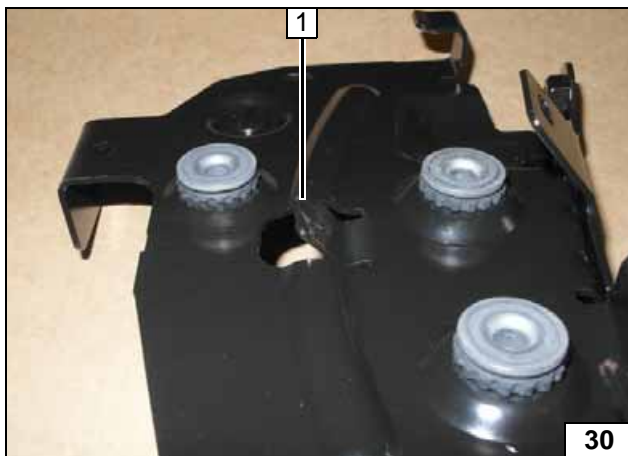

Bend tab 1 as shown.



Preparing original vehicle bracket

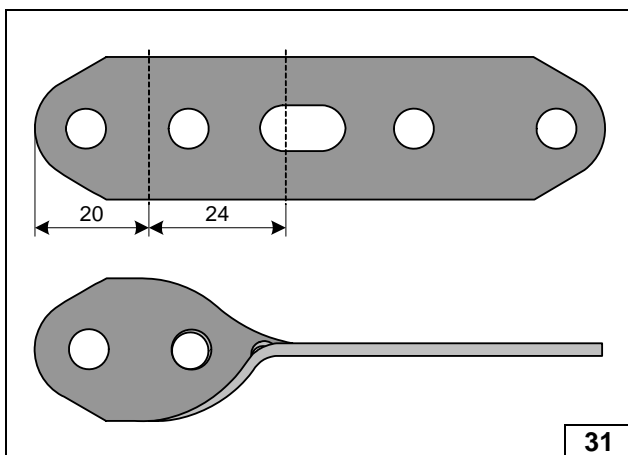

Twisting perforated bracket in longitudinal axis

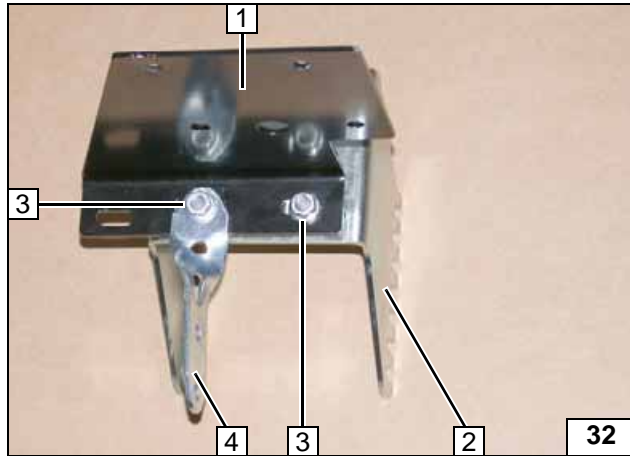
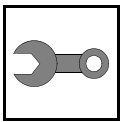

- 1 Retaining plate
- 2 Bracket
- 3 M6x16 bolt, flanged nut [2x each]
- 4 Perforated bracket

Premounting bracket

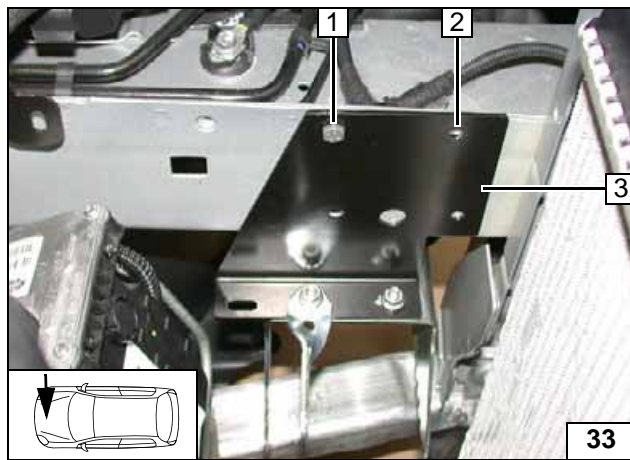

- 1 M6x20 bolt, existing threaded hole
- 2 Copy hole pattern
- 3 Install retaining plate with bracket loosely

Copying hole pattern

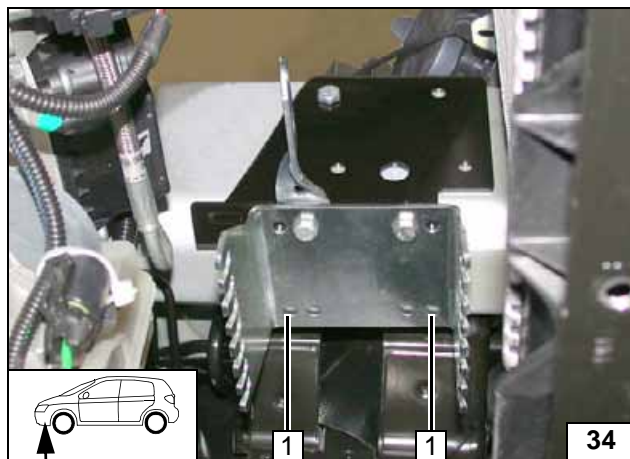

- 1 Copy hole pattern [2x]

Copying hole pattern

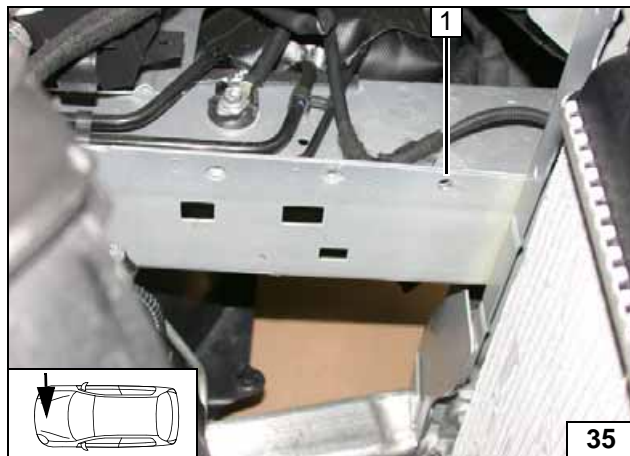

Remove retaining plate with bracket.

- 1 7 mm dia. hole



Hole in frame side member

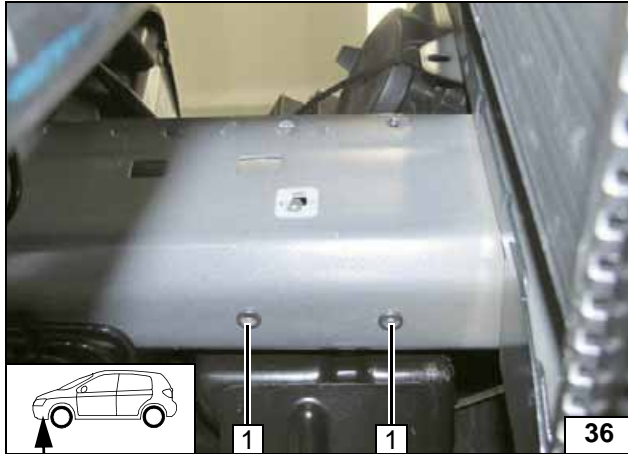
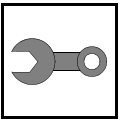

- 1 9.1mm dia. hole; rivet nut [2x each]

Installing rivet nut

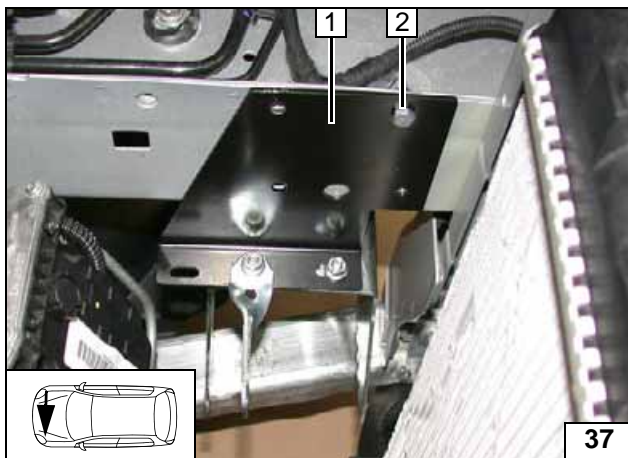

- 1 Retaining plate with bracket
- 2 M6x20 bolt, flanged nut

Installing bracket

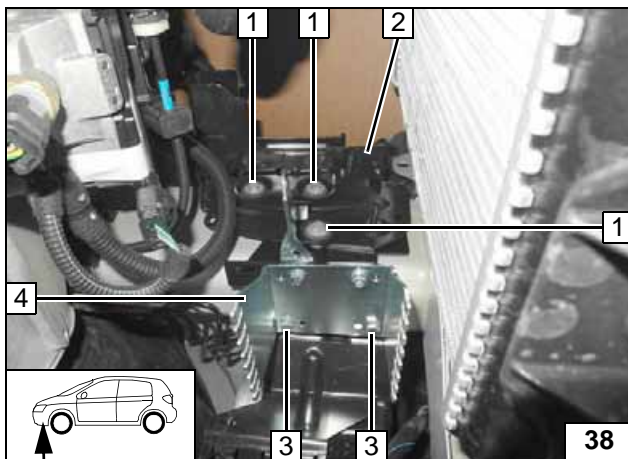

Insert one 20 mm shim each between bracket 4 and frame side member at position 3.

- 1 Original vehicle bolt [3x]
- 2 Original vehicle bracket
- 3 M6x35 bolt, spring lockwasher



Installing original vehicle bracket

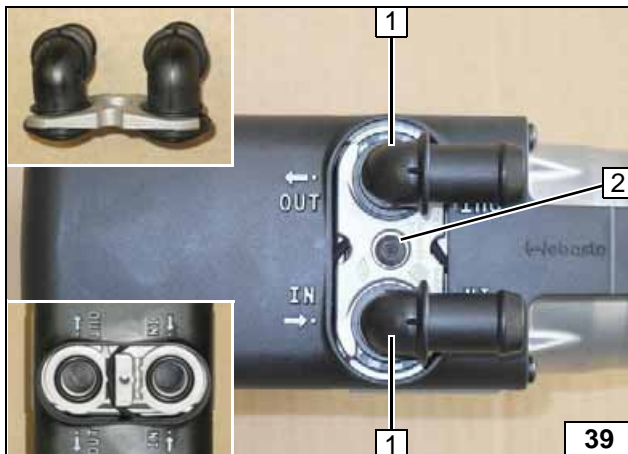

Preparing Heater

- 1 Water connection piece, sealing ring [2x each]
- 2 5x15 self-tapping bolt, retaining plate of water connection piece



Installing water connection piece

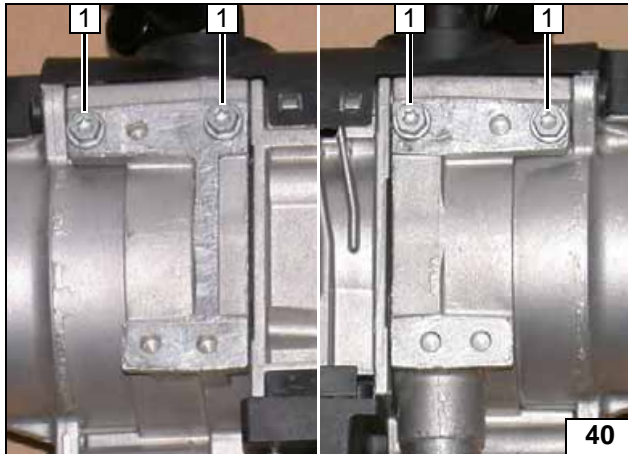
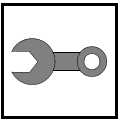

Screw 5x13 self-tapping bolts **1** [4x] into existing holes by a maximum of 3 thread turns.



Premounting bolts loosely

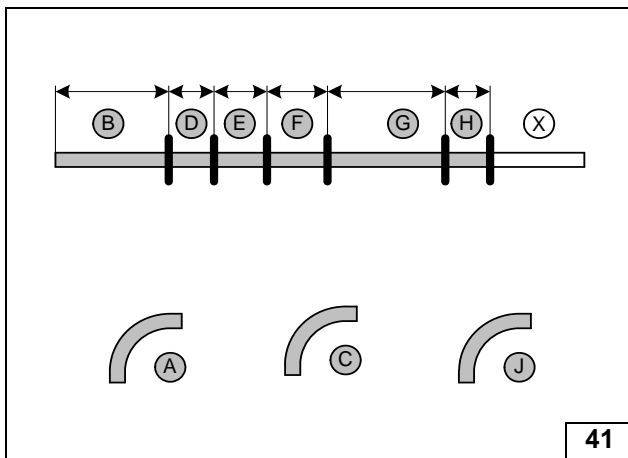

Discard section **X**.
Hoses **A**, **C** and **J** = 90°, 18mm dia. moulded hose.



Cutting hoses to length

- B** = 600
- D** = 60
- E** = 80
- F** = 100
- G** = 700
- H** = 60

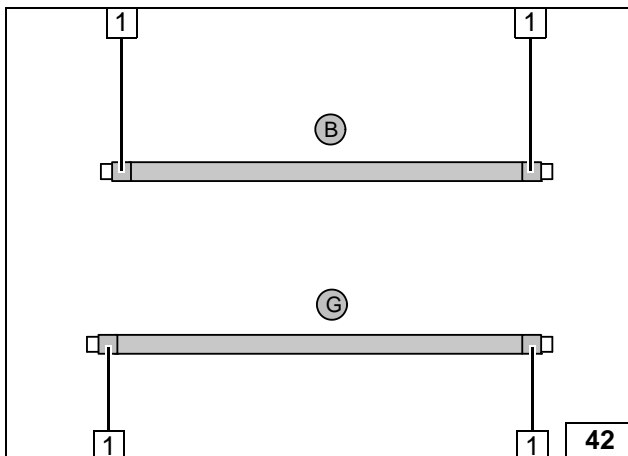

Push braided protection hoses onto hose **B** and **G** and cut to length. Cut heat shrink plastic tubing to size.



Preparing hoses

- 1** 50 mm long heat shrink plastic tubing [4x]

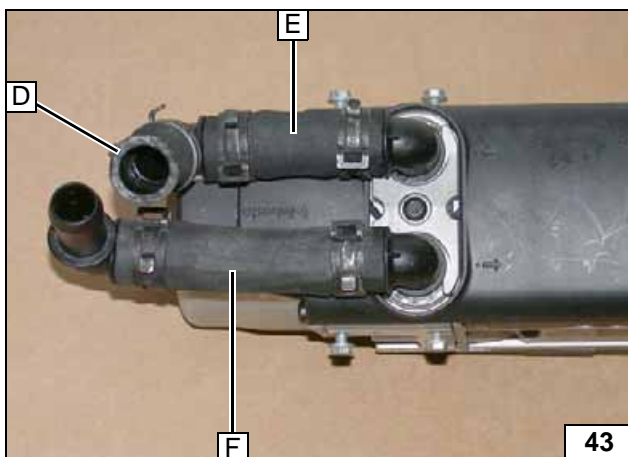

All spring clips = 25mm dia.!
All 90° connecting pipes 18x18 mm.



Premounting hoses

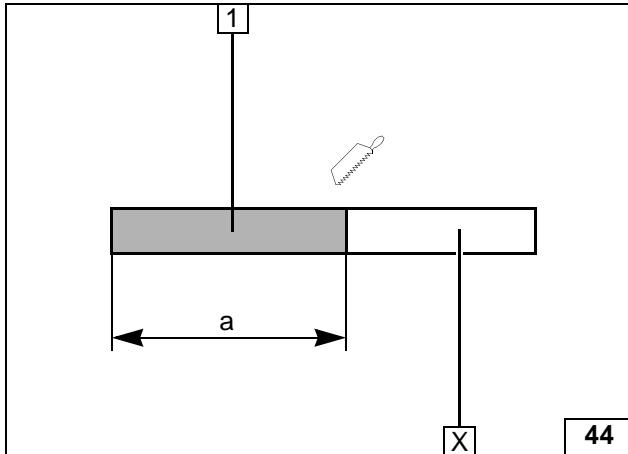
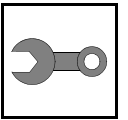

Discard section X.

- 1 Combustion air pipe
a = 260

Cutting combustion air pipe to length

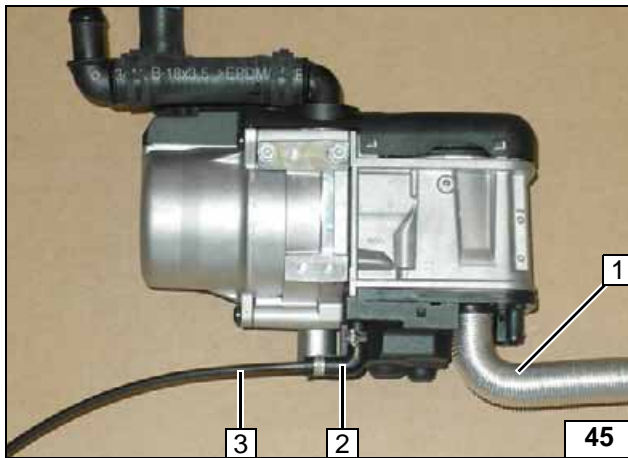

- 1 Combustion air pipe
- 2 90° moulded hose, 10mm dia. clamp [2x]
- 3 Fuel line

Installing combustion air pipe

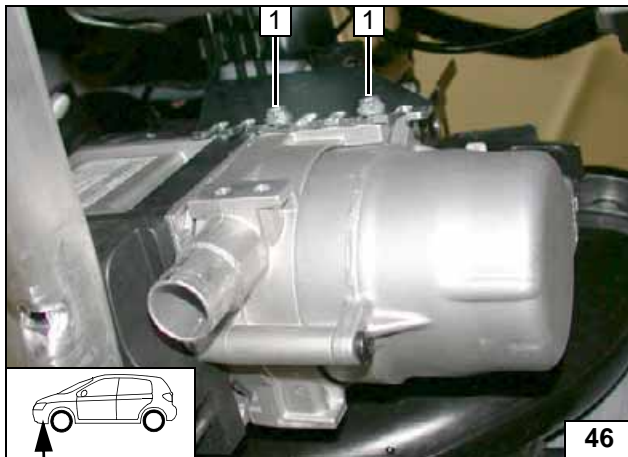

Installing Heater

- 1 Tighten 5x13 self-tapping bolt [2x]

Installing heater

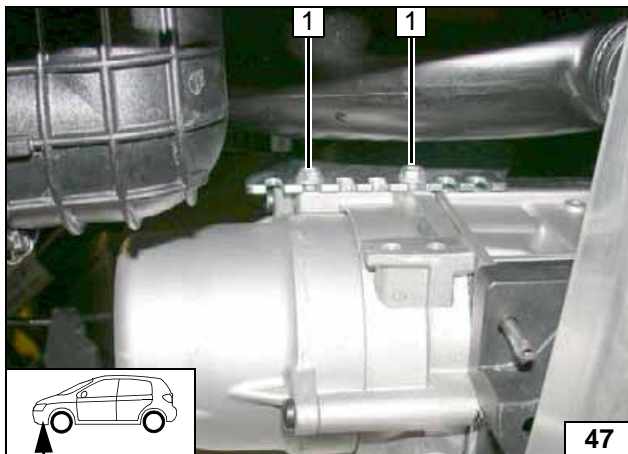

- 1 Tighten 5x13 self-tapping bolt [2x]

Installing heater

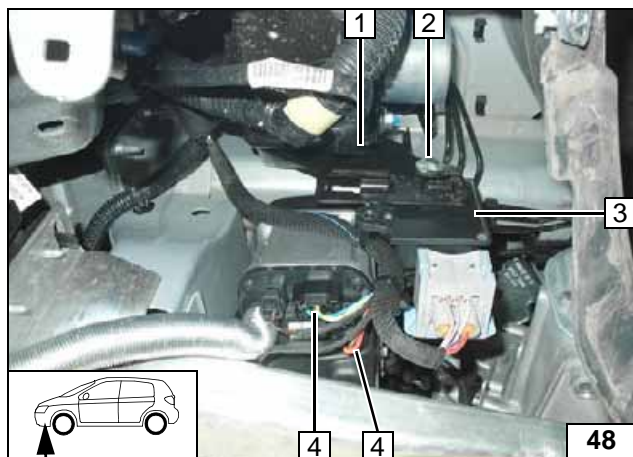
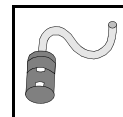

Combustion Air

- 1 ABS bracket
- 2 M6x20 bolt, large diameter washer, original vehicle hole, flanged nut
- 3 Relay
- 4 Insert heater wiring harness connector [2x]

Installing relay

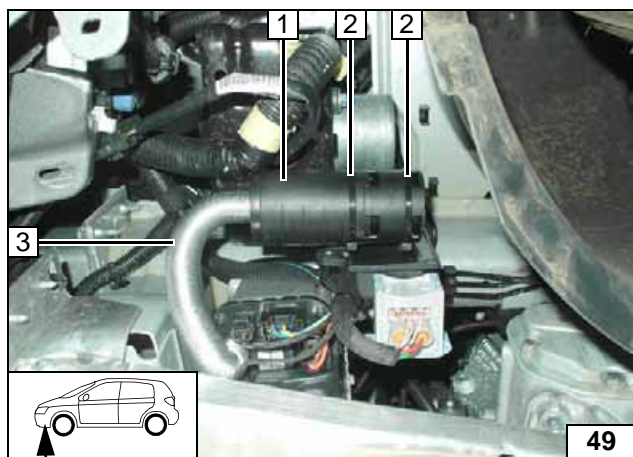

Attach silencer 1 to ABS bracket.

- 2 Cable tie [2x]
- 3 Combustion air pipe



Installing silencer



Fuel



Open the vehicle's fuel tank cap, ventilate the tank and then re-close the tank lock.

Catch any fuel running off in an appropriate container.



Route fuel line and metering pump wiring harness so that they are protected against stone impact. Unless specified otherwise, always fasten using cable ties.

Provide rub protection for fuel line and wiring harness in areas where there are sharp edges.

The fuel line and wiring harness are routed to the metering pump as shown in the wiring harness routing diagram.

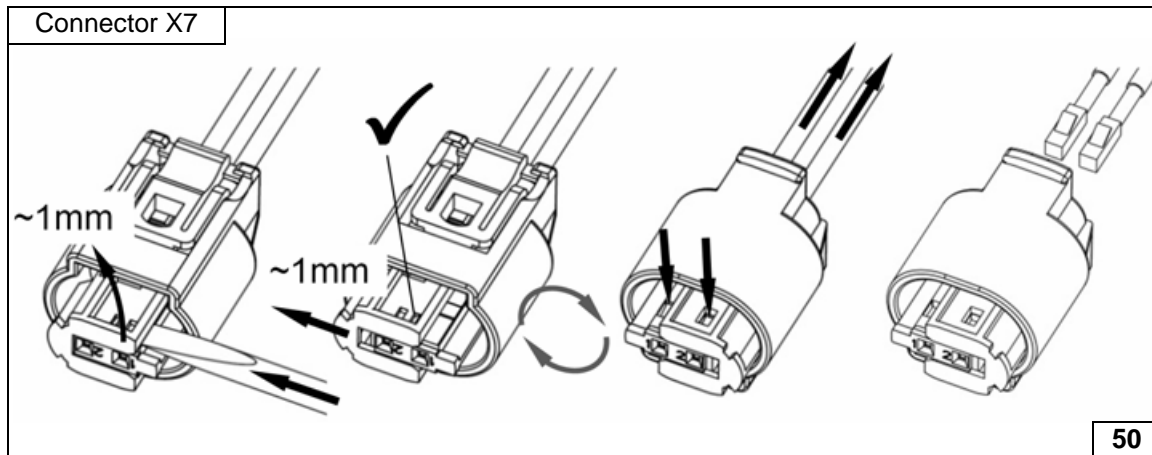

Dismantling metering pump connector

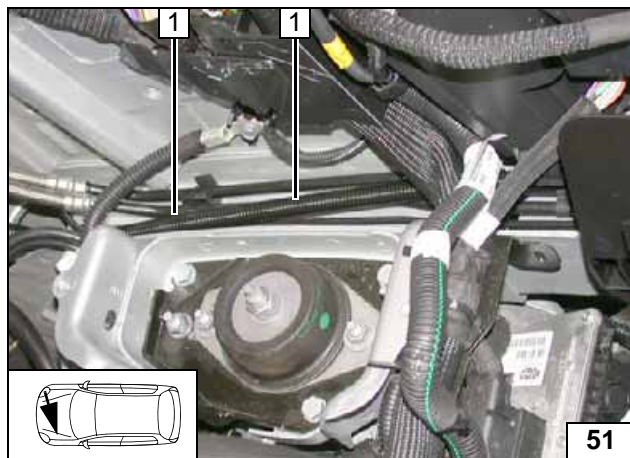

Route fuel line and wiring harness of metering pump into 2100mm corrugated tube 1 to the firewall and to the right side of the vehicle.



Routing lines

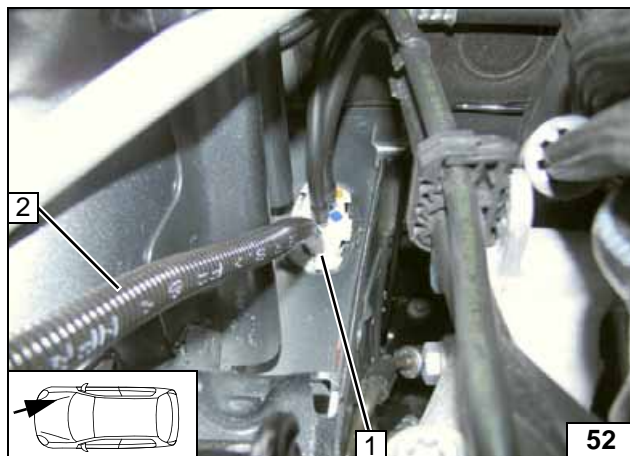

Route fuel line and wiring harness of metering pump in original vehicle line duct to the underbody.

- 1 Original vehicle pass through
- 2 Fuel line and wiring harness of metering pump in corrugated tube



Routing lines

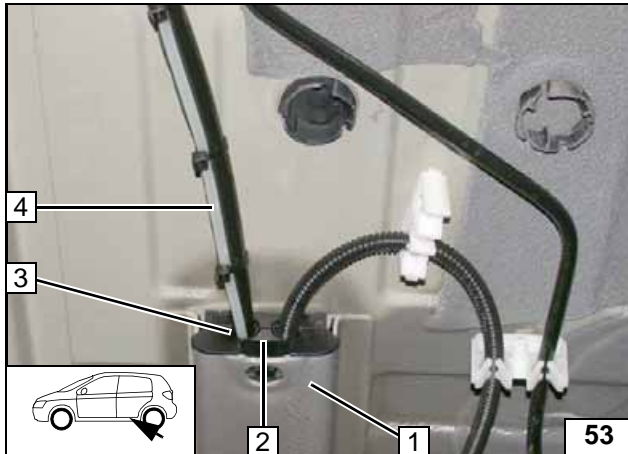

8mm dia. hole at position 3 in original vehicle sealing 2!

- 1 Original vehicle line duct
- 4 Fuel line, metering pump wiring harness

Routing lines

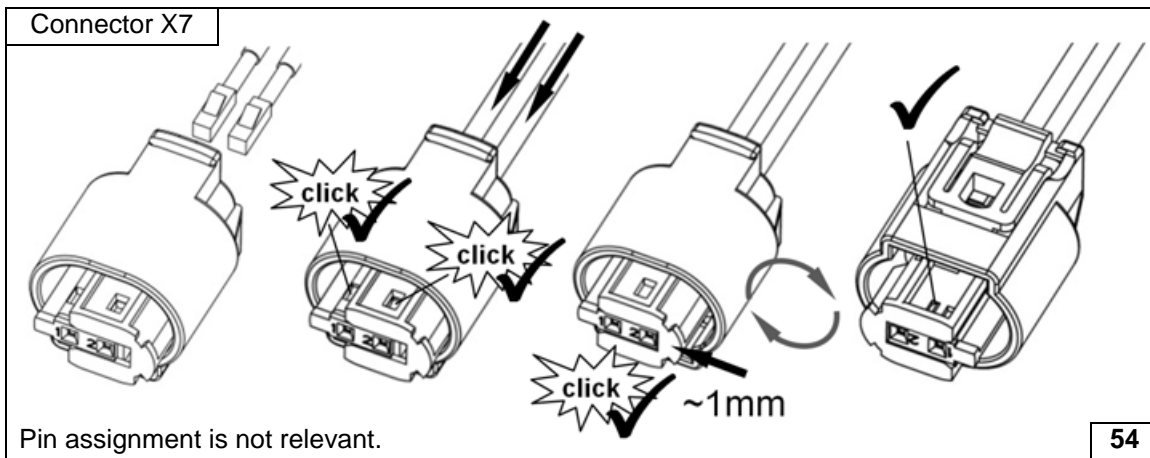

Pin assignment is not relevant.

54

Completing metering pump connector

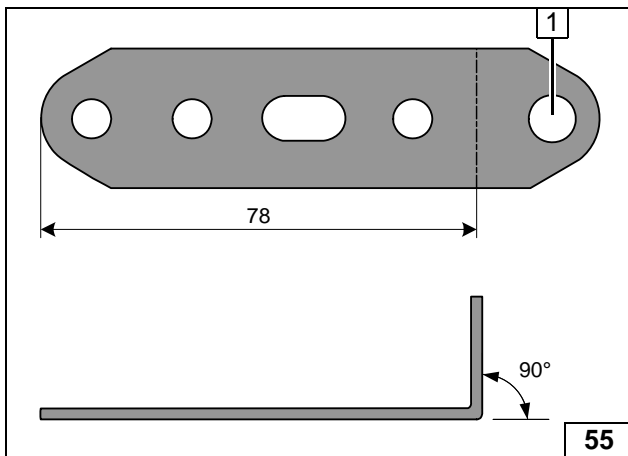

- 1 Drill out hole to 9 mm dia.

Preparing perforated bracket

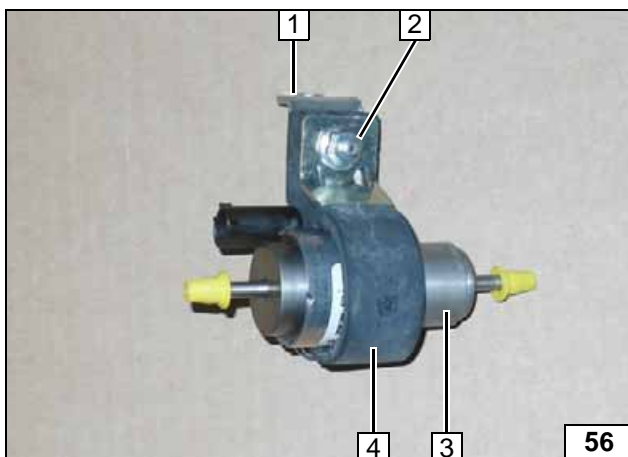

- 1 Perforated bracket
- 2 M6x25 bolt, support angle bracket, flanged nut
- 3 Metering pump
- 4 Metering pump mount

Premounting metering pump

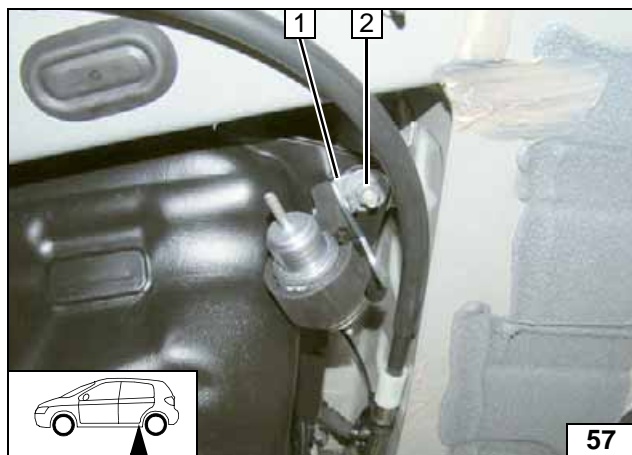
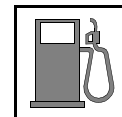

- 1 Perforated bracket
- 2 Original vehicle nut



Installing metering pump

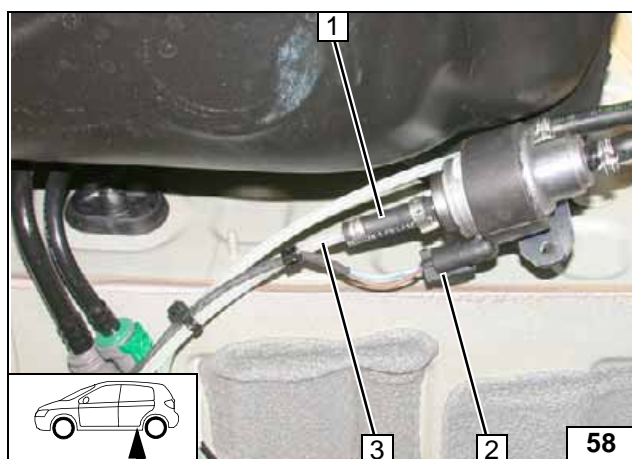

- 1 Hose section, 10mm dia. clamp [2x]
- 2 Metering pump wiring harness, connector mounted
- 3 Fuel line of heater

Connecting metering pump

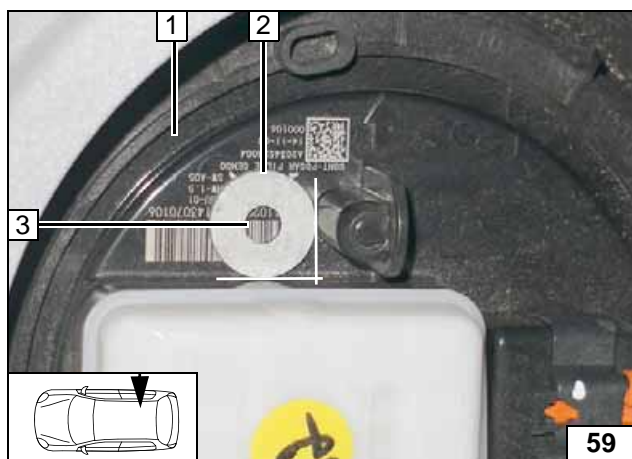

Installing FuelFix

Work steps F1 and F2.

- 1 Fuel tank sending unit
- 2 Position washer with outer dia. $d_a = 21.6\text{mm}$ as template against the raised parts.
- 3 Hole pattern



Copying hole pattern

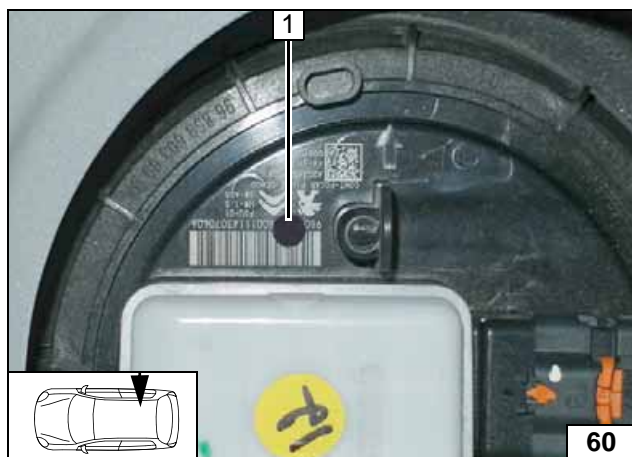

Work step F3.

- 1 Hole made with provided drill

Hole for FuelFix

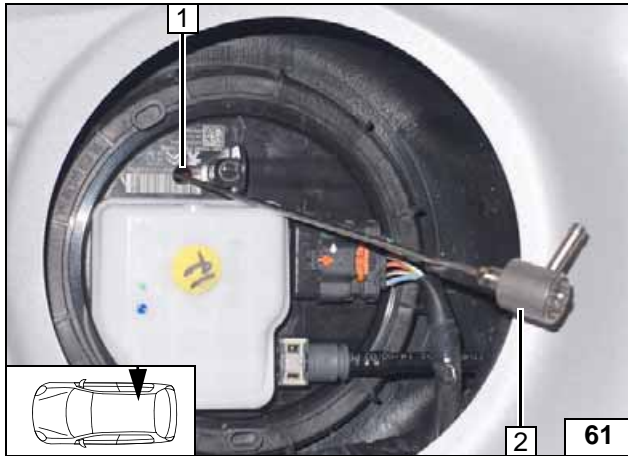

Work steps F4 and F5.

Bend FuelFix 2 according to template and cut to length. Insert into hole 1.



Inserting FuelFix

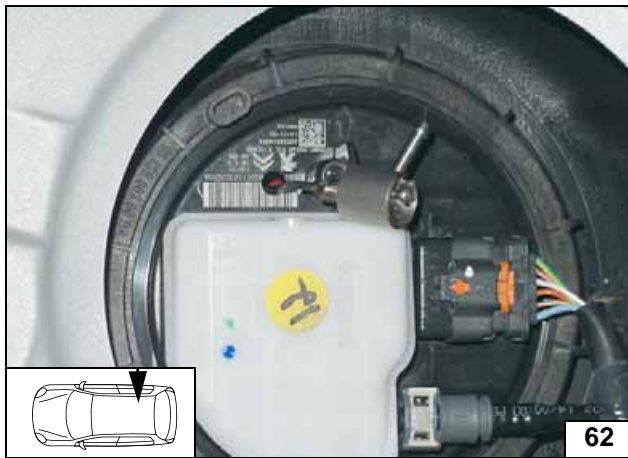

Work step F5.

Inserting FuelFix

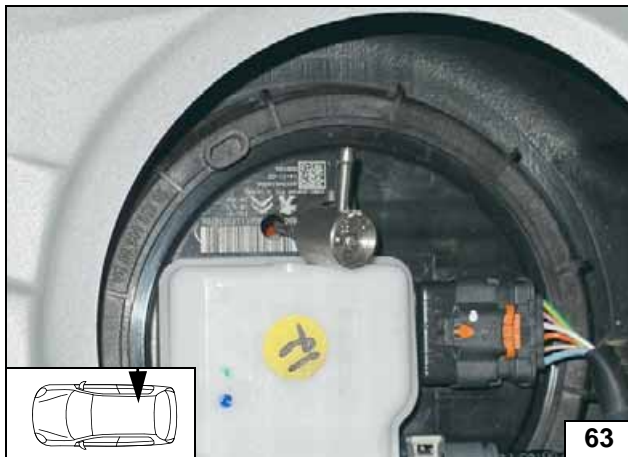

Inserting FuelFix

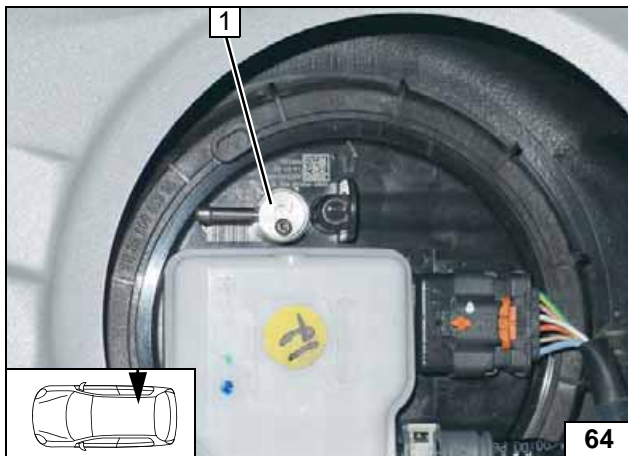

Work steps F5.3 and F5.4.

Align FuelFix 1 as shown.



Aligning FuelFix

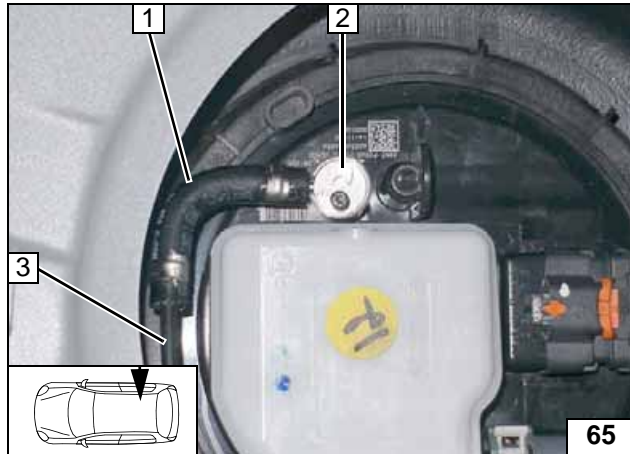

Work step F6.

- 1 90° moulded hose, 10mm dia. clamp [2x]
- 2 FuelFix
- 3 Fuel line

Connect-
ing fuel line

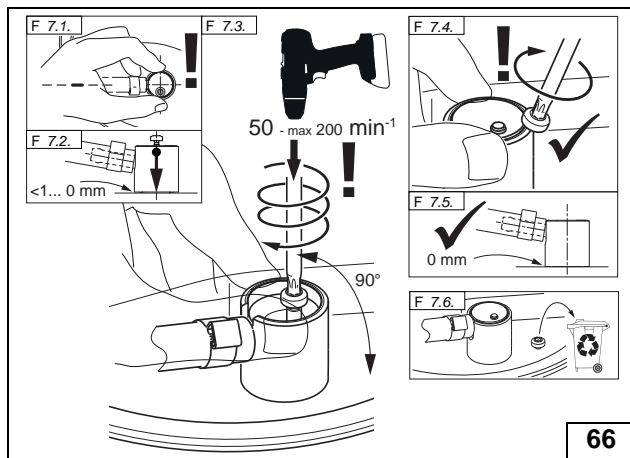

Work step F7.



Installing
FuelFix

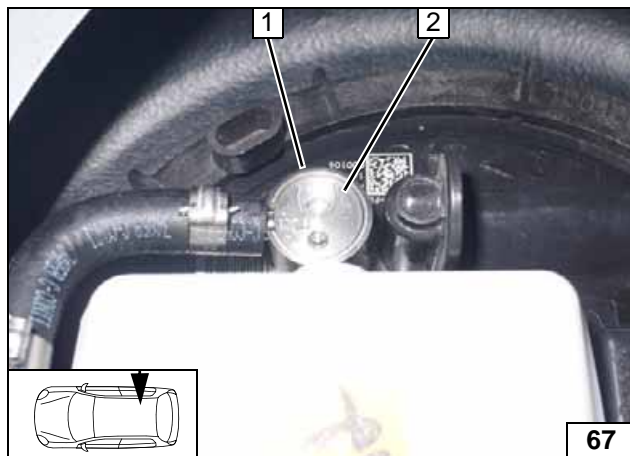

Work step F8.

Ensuring
firm seating
of FuelFix

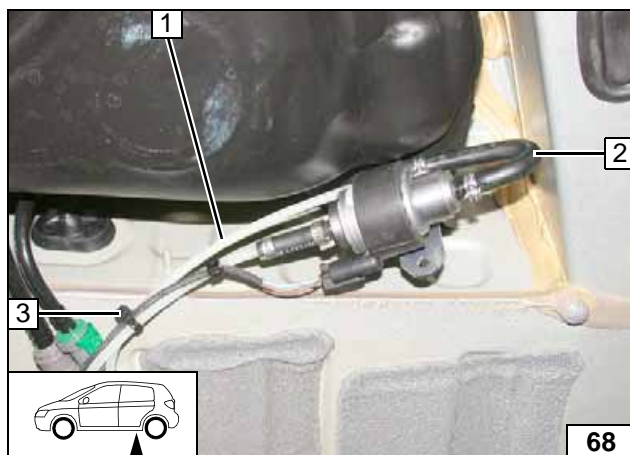

Ensure sufficient distance from neighbour-
ing components, correct if necessary.

- 1 Fuel line of FuelFix
- 2 180° moulded hose, 10mm dia. clamp [2x]
- 3 Cable tie as tension relief



Connect-
ing meter-
ing pump

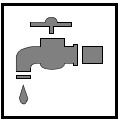

Coolant Circuit







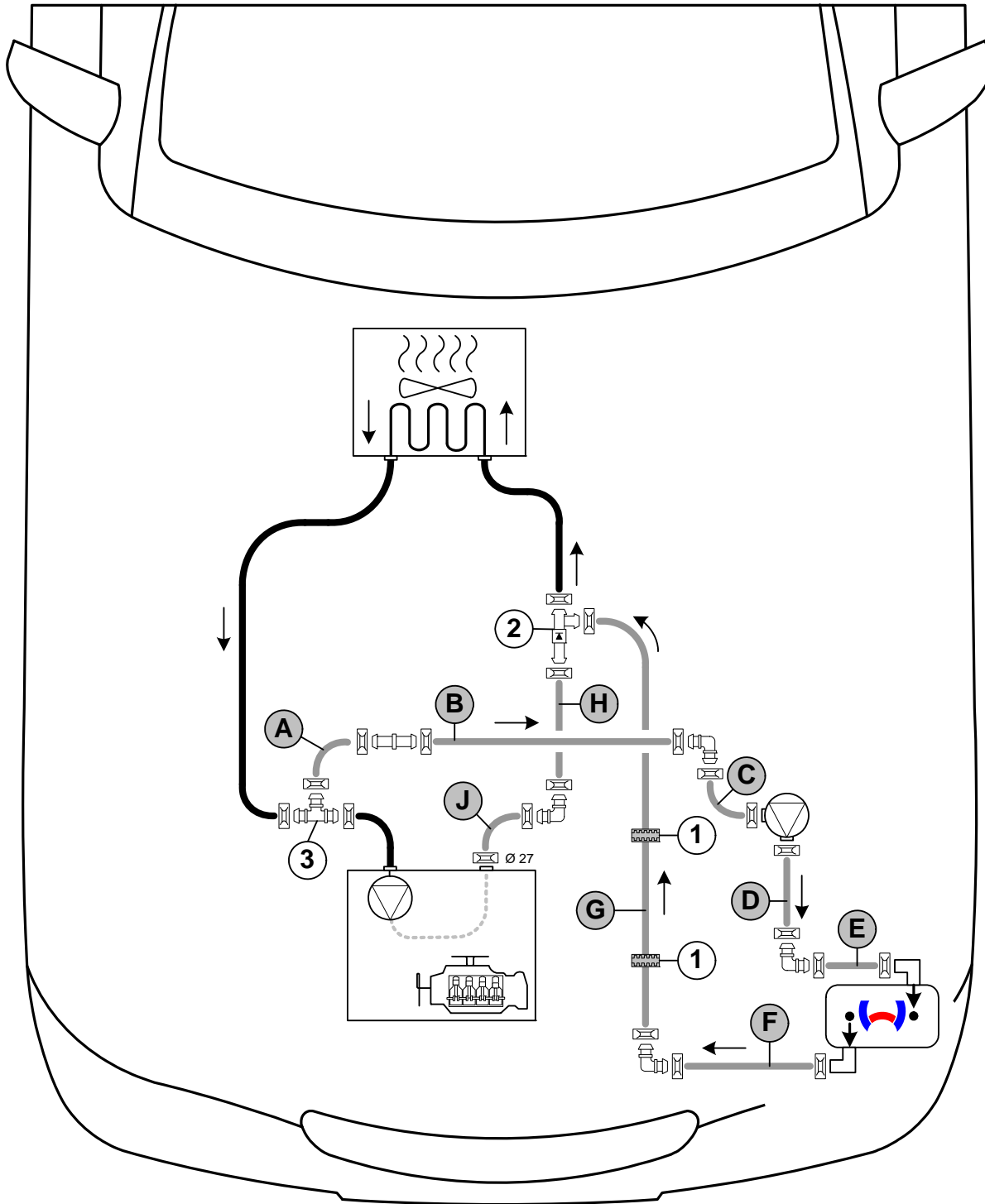

Any coolant running off should be collected in an appropriate container. Route hoses kink-free. Unless specified otherwise, always fasten using cable ties. Position clamps so that other hoses cannot be damaged. The heater must be filled with coolant when installing the hoses.

The connection should be modelled on an 'inline' circuit and based on the following diagram:



Hose routing diagram

All spring clips without a specific designation  = 25 mm dia. 27! 1 = Black (sw) rubber isolator .

All connecting pipes  and  = 18x18 mm dia. 2 = check valve . 3 = T-piece .



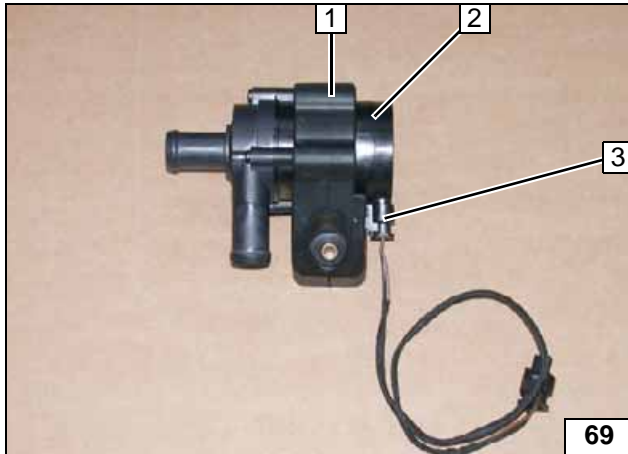

- 1 Circulating pump mount
- 2 Circulating pump
- 3 Connector of circulating pump wiring harness

Premounting circulating pump

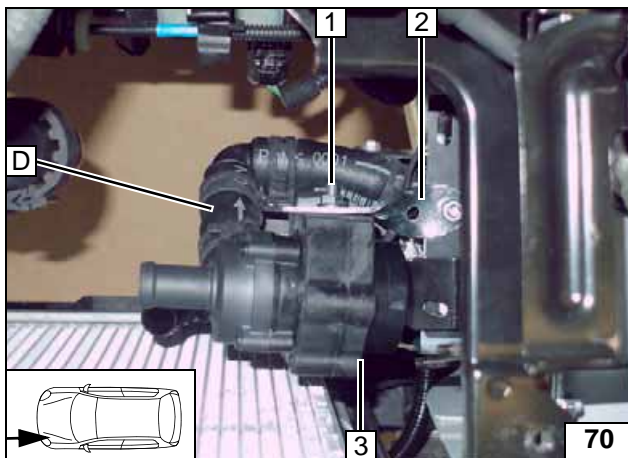

- 1 M6x25 bolt, flanged nut
- 2 Perforated bracket
- 3 Circulating pump mount

Installing circulating pump

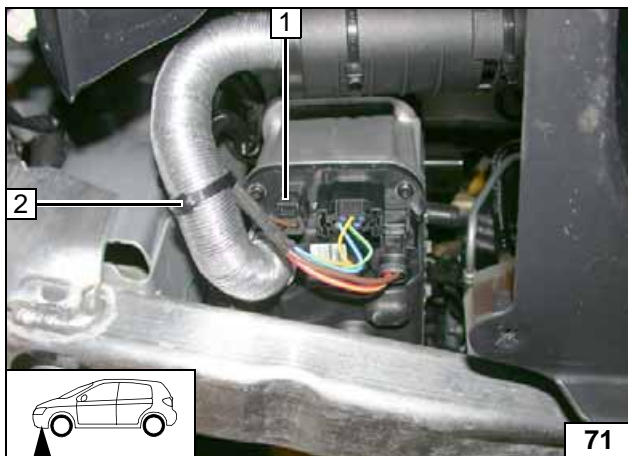

- 1 Circulating pump wiring harness
- 2 Cable tie

Mounting wiring harness

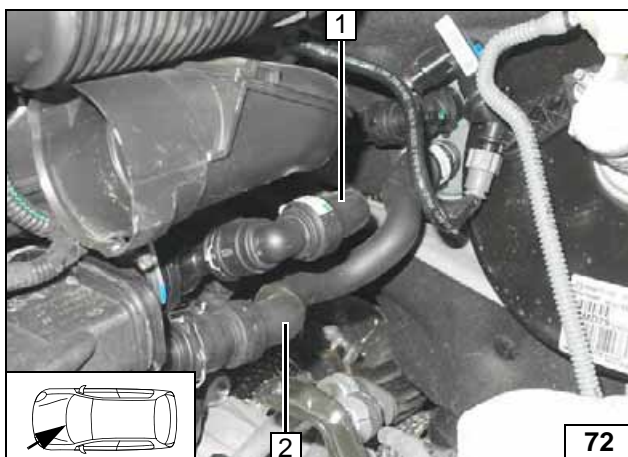

- 1 Remove hose of heat exchanger outlet / engine inlet
- 2 Remove hose of engine outlet / heat exchanger inlet

Removing hoses

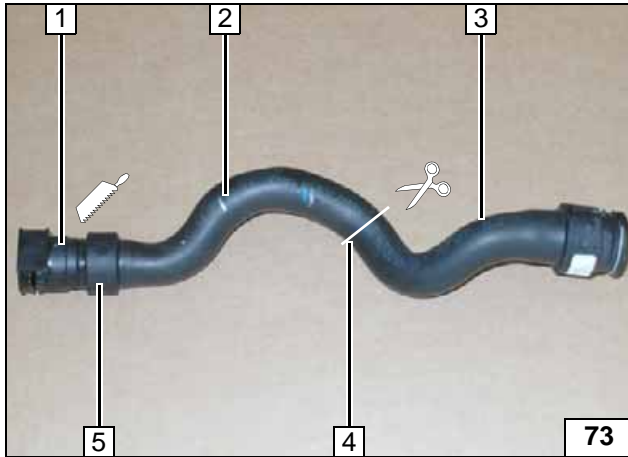

- 1 Coupling piece of engine outlet
- 2 Discard hose section
- 3 Heat exchanger inlet hose section
- 4 Cutting point
- 5 Open plastic ring carefully and discard

Cutting hose of engine outlet / heat exchanger inlet

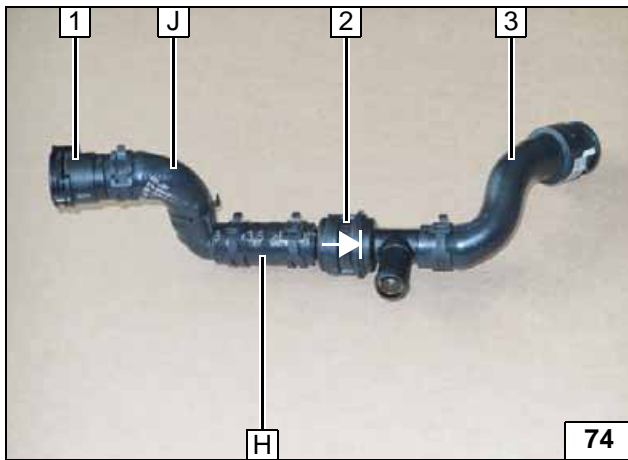

- 1 Coupling piece of engine outlet
- 2 18x18x18 check valve
- 3 Heat exchanger inlet hose section

Premounting check valve

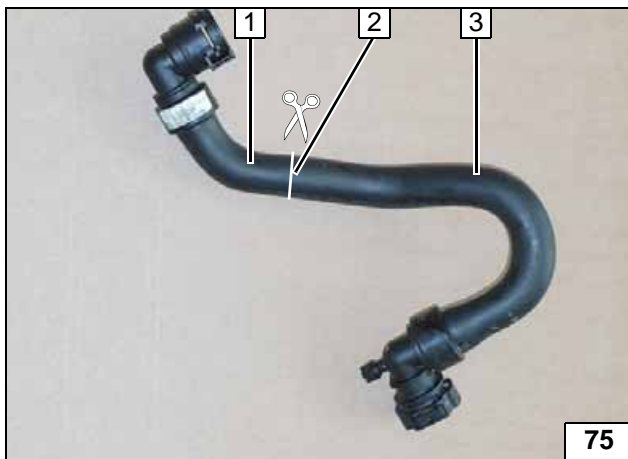

- 1 Engine inlet hose section
- 2 Cutting point
- 3 Heat exchanger inlet hose section

Cutting hose of heat exchanger outlet / engine inlet



- 1 Engine inlet hose section
- 2 18x18x18 T-piece
- 3 Heat exchanger inlet hose section

Premounting T-piece

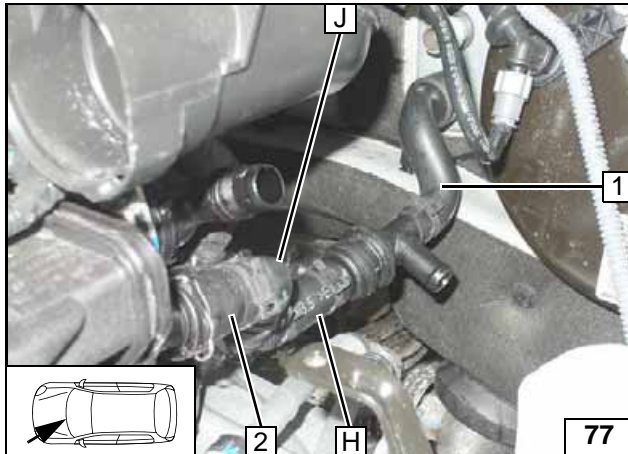

- 1 Heat exchanger inlet hose section
- 2 Coupling piece of engine outlet

Connect-
ing engine
outlet / heat
exchanger
inlet

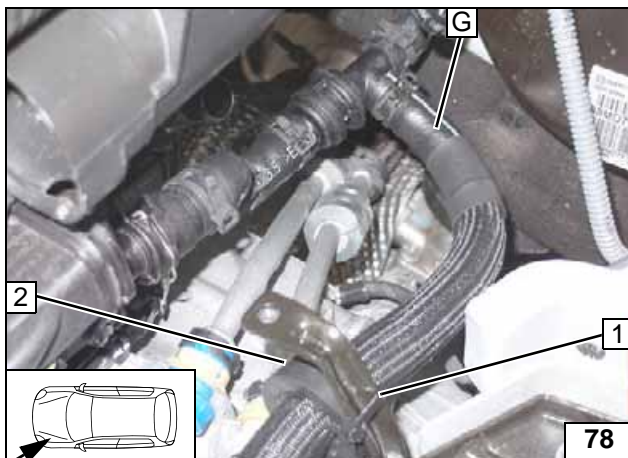

- 1 Cable tie
- 2 Black (sw) rubber isolator

Connect-
ing hose G

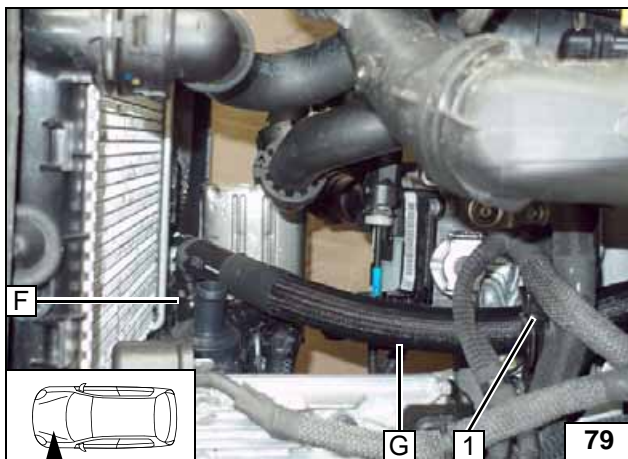

- 1 Cable tie and black (sw) rubber isola-
tor on strut

Routing in
engine
compartment
and
connection
of hose G

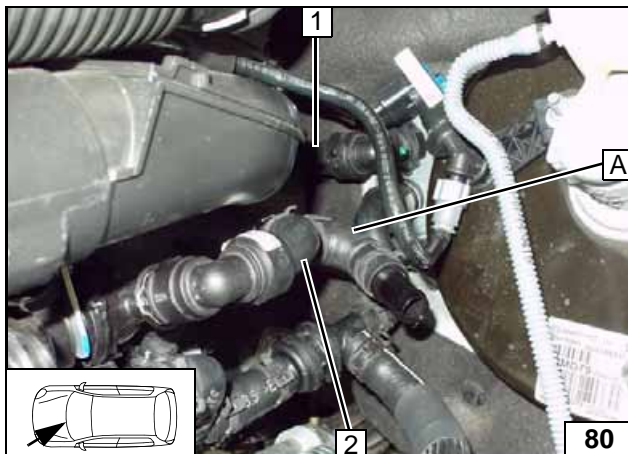

- 1 Heat exchanger outlet hose section
- 2 Engine inlet hose section

Connec-
tion of heat
exchanger
outlet / en-
gine inlet

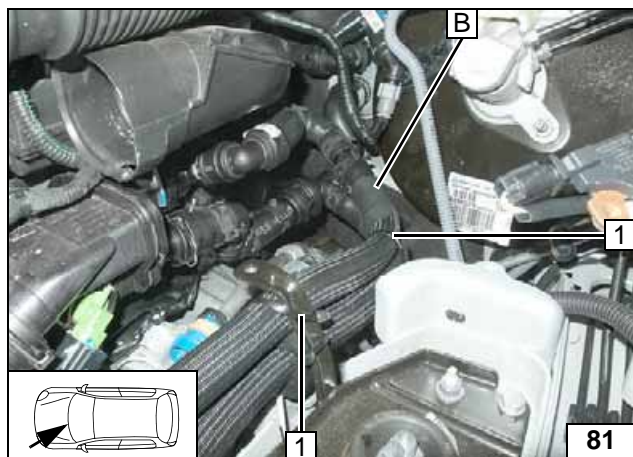

- 1 Black (sw) rubber isolator [2x]
- 2 Hose bracket
- 3 Cable tie

Connect-
ing hose B

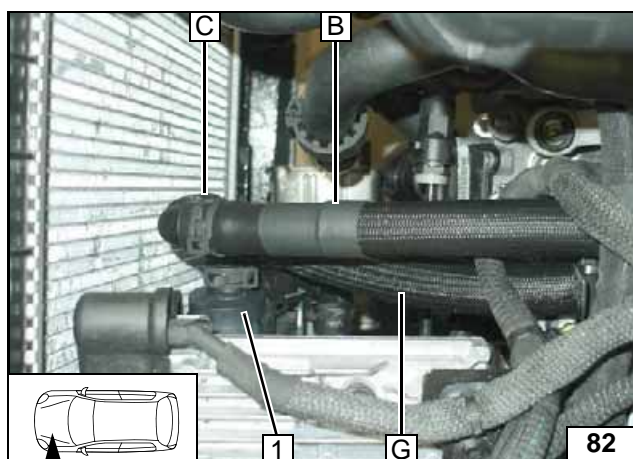

- 1 Circulating pump

Routing in
engine
compartment
and
connection
of hoses B
and C

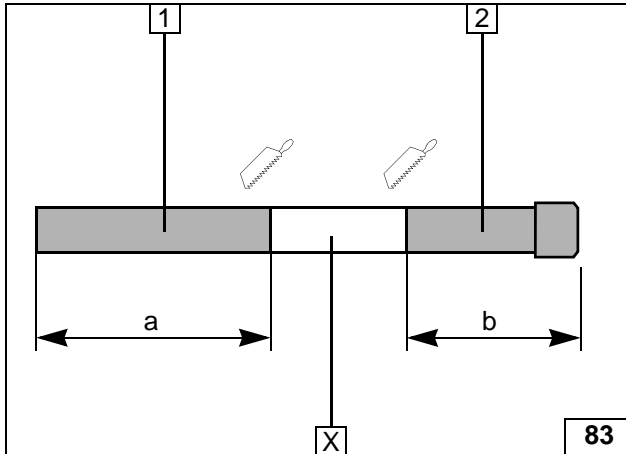
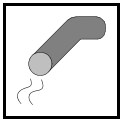

Exhaust Gas

Discard section X.

- 1 Exhaust pipe
a = 160
- 2 Exhaust end section
b = 135



Preparing exhaust pipe

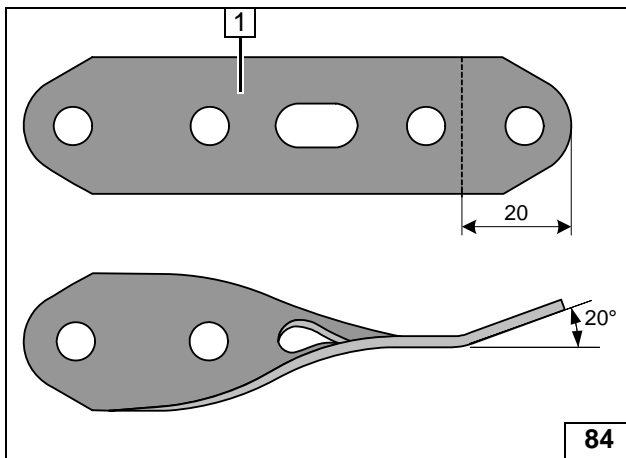

Twist perforated bracket 1 by 90° in the longitudinal axis and angle down.



Preparing perforated bracket of exhaust end section

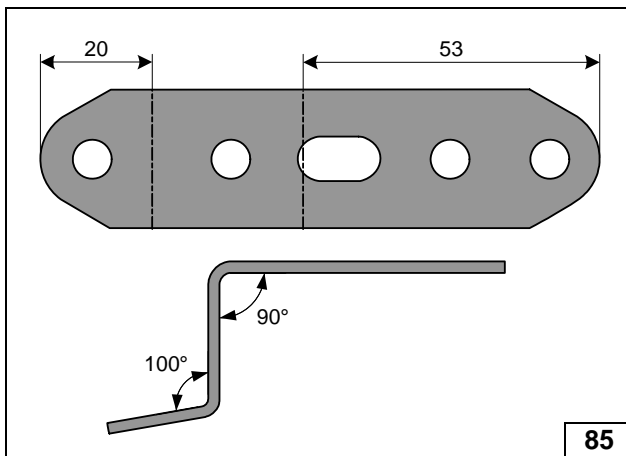

Angling down perforated bracket of silencer

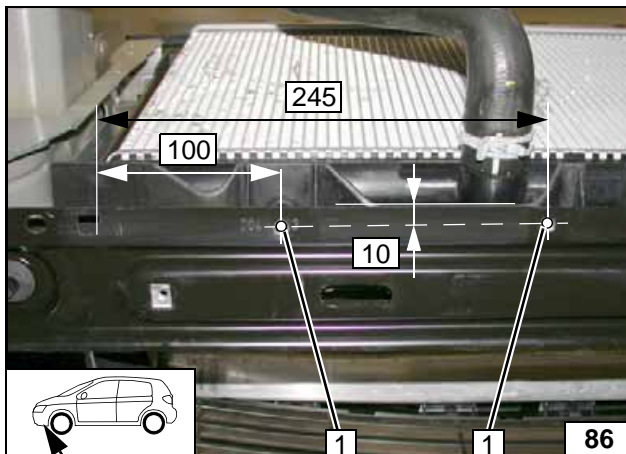

1 7mm dia. hole [2x]

Holes in cross member

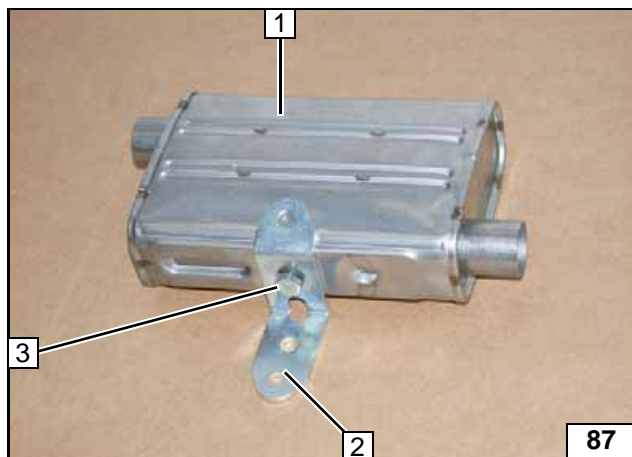
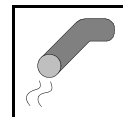

- 1 Silencer
- 2 Perforated bracket
- 3 M6x16 bolt, spring lockwasher

Premounting silencer

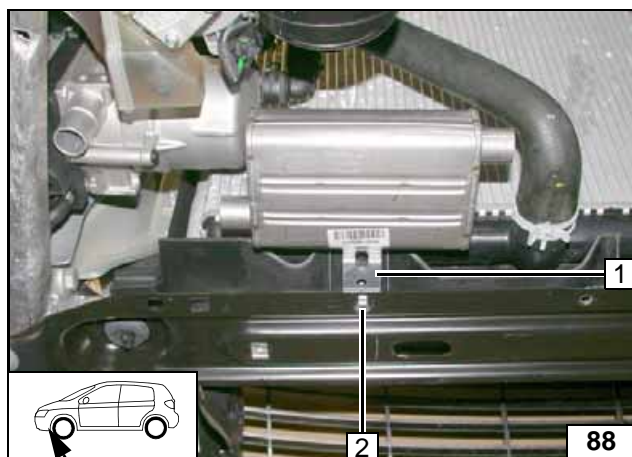

- 1 Perforated bracket
- 2 M6x12 bolt, flanged nut

Installing silencer

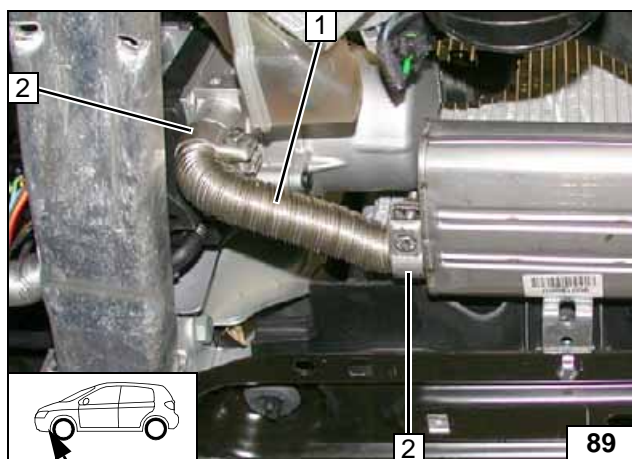

- 1 Exhaust pipe
- 2 Hose clamp [2x]

Installing exhaust pipe

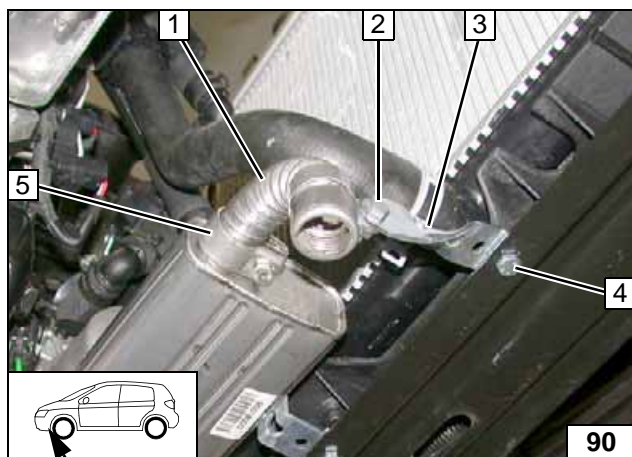

Ensure sufficient distance from neighbouring components, correct if necessary.



- 1 Exhaust end section
- 2 M6x20 bolt, p-clamp, flanged nut
- 3 Perforated bracket
- 4 M6x12 bolt, flanged nut
- 5 Hose clamp

Hole in underide protection



Final Work



Reassemble the components in reverse order. Check all hoses, clamps and all electrical connections for firm seating. Insulate and tie back all loose lines. Only use manufacturer-approved coolant. Spray the heater components with anti-corrosion wax (Tectyl 100K).

- Connect the battery.
- Fill and bleed the coolant circuit according to the vehicle manufacturer's instructions.
- Program MultiControl CAR, teach Telearstart transmitter.
- Make settings on the A/C control panel according to the 'operating instructions'.
- Place the 'Switch off parking heater before refuelling' caution label near the filler neck.
- For initial startup and function check, please see installation instructions.

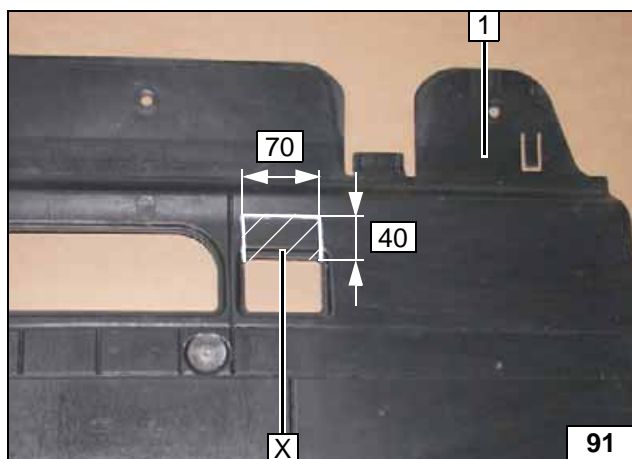

Discard section X.

1 Underride protection

**Cutting out
underride
protection**

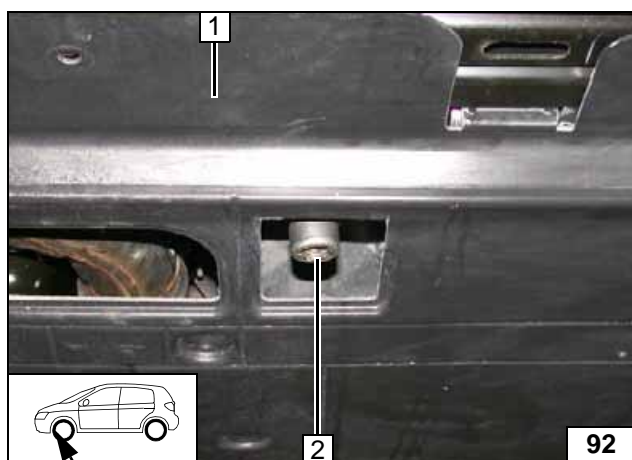

When installing underride protection 1, ensure sufficient distance from silencer, correct if necessary. Align exhaust end section 2 centrally in the recess of underride protection 1.



**Aligning ex-
haust end
section**

Webasto Thermo & Comfort SE
Postfach 1410
82199 Gilching
Germany
Internet: www.webasto.com
Technical Extranet:
<http://dealers.webasto.com>



FuelFix Template

Top view

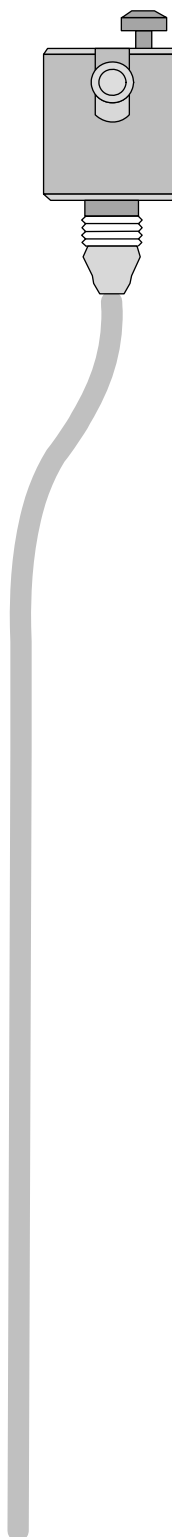
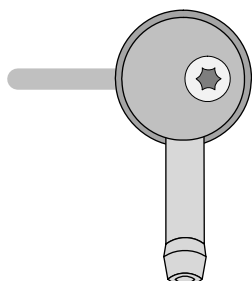

100mm



Scale 1:1

Compare size of printout with dimension lines.
Allowed tolerance a maximum of 2%.

Set the printer settings to 'no margin' or 'minimise margins' and 100% of the normal size.

100mm

0

Operating Instructions for Automatic A/C

Please remove page and add to the vehicle operating instructions.

Note:

We recommend matching the heating time to the driving time.
 Heating time = driving time

Example:

For a driving time of approx. 20 min. (in one direction), we recommend not exceeding a switch-on time of 20 min.

Passenger compartment monitoring, if installed, must be deactivated in addition to the vehicle settings for the heating operation.

For instructions on deactivation, please refer to the operating instructions of the vehicle.

Before parking the vehicle, make the following settings:



- 1 Air outlet faces upward
- 2 Set temperature on both sides to 'HI'



A/C control panel

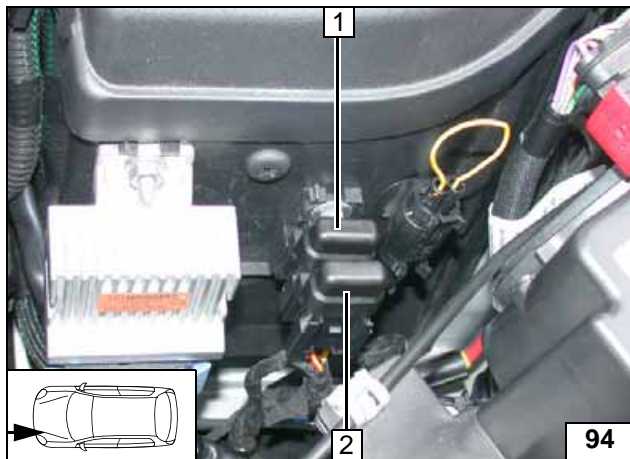

- 1 30A main fuse F2
- 2 20A heater fuse F1

Engine compartment fuses

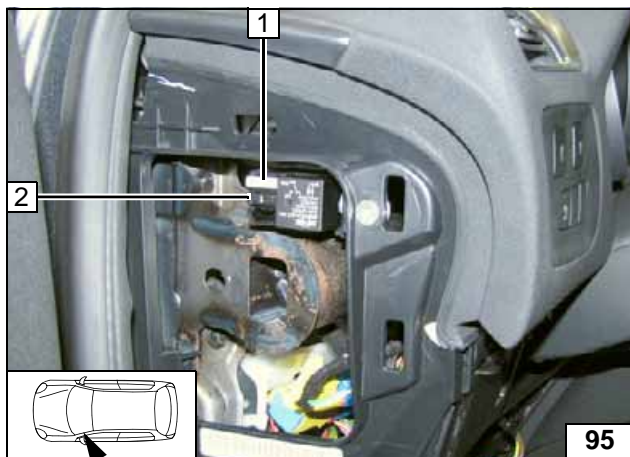

- 1 25A fan fuse F4
- 2 1A heater control fuse F3

Passenger compartment fuses

