



# Water Heater

Thermo Top Evo Parking Heater



## Installation Documentation Renault Kadjar

### Validity

Manufacturer	Model	Type	EG-BE No. / ABE
Renault	Kadjar	RFE	e2 * 2007 / 46 * 0475 *...

Motorisation	Fuel	Transmission type	Output in kW	Displacement in cm <sup>3</sup>	Engine code
1.5 D	Diesel	6-gear EDC	81	1461	K9K

EDC = dual clutch transmission

**From model year 2015**  
**Left-hand drive vehicle**

**Verified equipment variants:** 2 zone automatic air-conditioning  
2 WD  
LED main headlights  
LED daytime running lights  
Halogen front fog lights  
Start button  
Start / Stop  
Euro 6 Emission standard

**Not verified:** Manual air-conditioning  
Passenger compartment monitoring  
Headlight washer system

**Total installation time:** approx. 7 hours without A/C control  
approx. 8 hours with A/C control 'Standard' or 'Comfort'

# Renault Kadjar

## Table of Contents

Validity	1	Thermo Call Option	10
Necessary Components	2	Preparing Installation Location	11
Installation Overview	2	Preparing Heater	13
Information on Total Installation Time	2	Installing Heater	14
Information on Operating and Installation Instructions	3	Fuel	15
Information on Validity	4	Coolant Circuit	18
Technical Information	4	Exhaust Gas	23
Explanatory Notes on Document	4	Installing Relay Box	26
Preliminary Work	5	Final Work	32
Heater Installation Location	5	Template for Fuel Standpipe	33
Preparing Electrical System	6		
Electrical System	7		
Air-Conditioning Control	8		
MultiControl CAR Option	9		
Remote Option (Telestart)	9		

## Necessary Components

- Basic delivery scope of Thermo Top Evo based on price list
- Installation kit for Renault Kadjar 2015 Diesel: **1324574A**
- Additional kit A/C control for automatic air-conditioning: 'Standard': **1324475\_**  
or  
Additional kit A/C control for automatic air-conditioning: 'Comfort': **1324068\_**
- Heater control in accordance with price list and upon consultation with end customer
- In case of Telestart, indicator lamp in accordance with price list and in consultation with end customer

## Installation instructions:

- Arrange for the vehicle to be delivered with the tank only about ¼ full.
- The installation location of the push button in case of Telestart or Thermo Call should be confirmed with the end customer.
- Depending on the available space and manufacturer's instructions, we recommend the use of a vehicle battery with more electrical capacity.

## Installation Overview

### Legend:

1. Heater
2. Engine compartment fuse holder
3. Circulating pump
4. MultiControl CAR
5. Metering pump

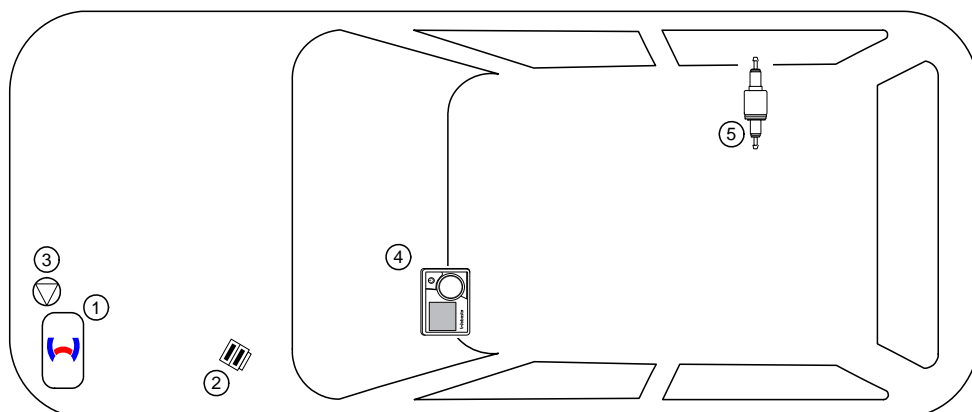

## Information on Total Installation Time

The total installation time includes the time needed for mounting and demounting the vehicle-specific components, the heater specific installation time and all other times required for the system integration and initial start-up of the heater. The total installation time may vary for vehicle equipment other than provided.

## Information on Operating and Installation Instructions

### 1 Important information (not complete)

#### 1.1 Installation and repair



The improper installation or repair of Webasto heating and cooling systems can cause fire or the leakage of deadly carbon monoxide, leading to serious injury or death.



To install and repair Webasto heating and cooling systems you need to have completed a special company training course and have the appropriate technical documentation, special tools and special equipment.



Installation and repair may ONLY be carried out by persons trained and certified in a Webasto training course. NEVER try to install or repair Webasto heating or cooling systems if you have not completed a Webasto training course, you do not have the necessary technical skills and you do not have the technical documentation, tools and equipment available to ensure that you can complete the installation and repair work properly.

Only use genuine Webasto parts. See the Webasto air and water heaters accessories catalogue for this purpose.

#### 1.2 Operation

To ensure safe operation, we recommend having the heater checked every two years by an authorised Webasto dealer, especially when used over a long period and/or under extreme environmental conditions.

Do not operate the heater in closed rooms due to the danger of poisoning and suffocation.

Always switch off the heater before refuelling.

The heater may only be used with the prescribed fuel diesel (DIN EN 590) or petrol (DIN EN 228).

The heater may not be cleaned with a high-pressure cleaner.

#### 1.3 Please note

ALWAYS follow all Webasto installation and operating instructions and observe all warnings.

To become familiar with and understand all functions and properties of the heater, the operating instructions must be read carefully and observed at all times.

For proper, safe installation and repair work, the installation instructions with all warnings and safety information must be carefully read and observed at all times. Please always contact a workshop authorised by Webasto for all installation and repair work.

#### Important

**Webasto shall assume no liability for defects, damage and injuries resulting from a failure to observe the installation, repair and operating instructions of the information contained in them.**

**This liability exclusion particularly applies to improper installations and repairs, installations and repairs by untrained persons or in the case of a failure to use genuine spare parts.**

**The liability due to culpable disregard to life, limb or health and due to damage or injuries caused by a wilful or reckless breach of duty remain unaffected, as does the obligatory product liability.**

Installation should be carried out according to the general, standard rules of technology. Unless specified otherwise, fasten hoses, lines and wiring harnesses to original vehicle lines and wiring harnesses using cable ties. Insulate loose wire ends and tie back. Connectors on electronic components have to audibly click into place during installation.

Sharp edges should be fitted with rub protection. Spray unfinished body areas, e.g. drilled holes, with anti-corrosion wax (Tectyl 100K).

Observe the instructions and guidelines of the respective vehicle manufacturer for demounting and mounting vehicle specific components!

The initial startup is to be executed with the Webasto Thermo Test Diagnosis.

When installing a programmable control module (e.g. a PWM Gateway), the corresponding settings must be checked or adjusted.

### 2 Statutory regulations governing installation

Guidelines	Thermo Top Evo
Heating Directive ECE R122	E1 00 0258
EMC Directive ECE R10	E1 04 5627

#### Note

The regulations of these guidelines are binding in the scope of the Directive 70/156/EEC and/or 2007/46/EC (for new vehicle models from 29/04/2009) and should also be observed in countries in which there are no special regulations.

#### Important

Failure to follow the installation instructions will result in the invalidation of the type approval for the heater and therefore invalidation of the general **homologation of the vehicle**.

#### Note

The heater is licensed in accordance with paragraph 19, section 3, No. 2b of the StVZO (German Road Traffic Licensing Authority).

### 2.1 Excerpt from ECE regulation 122 (heating system) paragraph 5 for the installation of the heater

Beginning of excerpt.

#### ANNEX VII

#### REQUIREMENTS FOR COMBUSTION HEATERS AND THEIR INSTALLATION

##### 1. GENERAL REQUIREMENTS

1.7.1. A clearly visible tell-tale in the operator's field of view shall inform when the combustion heater is switched on or off.

##### 2. VEHICLE INSTALLATION REQUIREMENTS

###### 2.1. Scope

2.1.1. Subject to paragraph 2.1.2, combustion heaters shall be installed according to the requirements of this Annex.

2.1.2. Vehicles of category O having liquid fuel heaters are deemed to comply with the requirements of this Annex.

###### 2.2. Positioning of heater

2.2.1. Body sections and any other components in the vicinity of the heater must be protected from excessive heat and the possibility of fuel or oil contamination.

2.2.2. The combustion heater shall not constitute a risk of fire, even in the case of overheating. This requirement shall be deemed to be fulfilled if the installation ensures an adequate distance to all parts and suitable ventilation, by the use of fire resistant materials or by the use of heat shields.

2.2.3. In the case of M2 and M3 vehicles, the heater must not be positioned in the passenger compartment. However, an installation in an effectively sealed envelope which also complies with the conditions in paragraph 2.2.2 may be used.

2.2.4. The label referred to in paragraph 1.4 or a duplicate, must be positioned so that it can be easily read when the heater is installed in the vehicle.

2.2.5. Every reasonable precaution should be taken in positioning the heater to minimise the risk of injury and damage to personal property.

###### 2.3. Fuel supply

2.3.1. The fuel filler must not be situated in the passenger compartment and must be provided with an effective cap to prevent fuel spillage.

2.3.2. In the case of liquid fuel heaters, where a supply separate to that of the vehicle is provided, the type of fuel and its filler point must be clearly labelled.

2.3.3. A notice, indicating that the heater must be shut down before refuelling, must be affixed to the fuelling point. In addition a suitable instruction must be included in the manufacturer's operating manual.

###### 2.4. Exhaust system

2.4.1. The exhaust outlet must be located so as to prevent emissions from entering the vehicle through ventilators, heated air inlets or opening windows.

###### 2.5. Combustion air inlet

2.5.1. The air for the combustion chamber of the heater must not be drawn from the passenger compartment of the vehicle.

2.5.2. The air inlet must be so positioned or guarded that blocking by rubbish or luggage is unlikely.

###### 2.6. Heating air inlet

2.6.1. The heating air supply may be fresh or recirculated air and must be drawn from a clean area not likely to be contaminated by exhaust fumes emitted either by the propulsion engine, the combustion heater or any other vehicle source.

2.6.2. The inlet duct must be protected by mesh or other suitable means.

###### 2.7. Heating air outlet

2.7.1. Any ducting used to route the hot air through the vehicle must be so positioned or protected that no injury or damage could be caused if it were to be touched.

2.7.2. The air outlet must be so positioned or guarded that blocking by rubbish or luggage is unlikely.

End of excerpt.

In multilingual versions the German language is binding.

# Renault Kadjar

## Information on Validity

This installation documentation applies to Renault Kadjar Diesel vehicles - for validity, see page 1 - from model year 2015 and later, assuming technical modifications to the vehicle do not affect installation, any liability claims excluded. Depending on the vehicle version and equipment, modifications may be necessary during installation with respect to this 'installation documentation'.

Vehicle and engine types, equipment variants and other specifications not listed in this installation documentation have not been tested. However, installation according to this installation documentation may be possible.

## Technical Information

### Special Tools

- Hose clamp pliers for auto-tightening hose clamps
- Hose clamp pliers for Clic hose clamps of type W
- Automatic wire stripper, 0.2 - 6mm<sup>2</sup>
- Crimping pliers for cable lug / tab connector, 0.5 - 6mm<sup>2</sup>
- Torque wrench for 2.0 - 10 Nm
- Hose clamping pliers
- Metric thread-setter kit
- Deep-hole marker
- Webasto Thermo Test Diagnosis with current software

### Dimensions

- All dimensions are in mm.

### Tightening torque values

- Tightening torque values of 5x13 heater bolts and 5x11 heater stud bolts = 8Nm.
- Tightening torque value of 5x15 water connection piece retaining plate bolt = 7Nm.
- Tighten other bolt connections in accordance with manufacturer's instructions or in accordance with state-of-the-art technology.

## Explanatory Notes on Document

You will find an identification mark on the outside top right corner of the page in question to provide you with a quick overview of the individual working steps.

Special features are highlighted using the following symbols:

**Mechanical System**



**Electrical System**



**Coolant Circuit**



**Combustion Air**



**Fuel**



**Exhaust Gas**



**Software**



**Specific risk of damage to components.**



**Specific risk due to electrical voltage.**



**Specific risk of injury or fatal accidents.**



**Specific risk of fire or explosion.**



**Reference to the manufacturer's vehicle-specific documents or to the general installation instructions of Webasto components.**



**Reference to a special technical feature.**



**The arrow in the vehicle icon indicates the position on the vehicle and the viewing angle.**



**Tightening torque according to the manufacturer's vehicle-specific documents.**



## Preliminary Work

### Vehicle



- Open the fuel tank cap.
- Ventilate the fuel tank.
- Close the fuel tank cap again.
- Depressurise the cooling system.
- When a 'Standard' additional kit is used, carry out all the preliminary work as explained in the 'Standard additional kit' installation documentation before disconnecting the battery!
- Disconnect and completely remove the battery, including the carrier.
- Remove the air filter completely up to the engine, together with the intake hose.
- Remove the left front wheel.
- Detach the wheel well trim on the front right side.
- Remove the front left wheel well trim.
- Remove the bumper trim.
- Remove the underride protection of the engine.
- Remove the right underbody underride protection.
- Remove the rear seats.



Only carry out the following steps during the corresponding installation sequence:



- Open the tank-fitting service lid.
- Remove the fuel tank sending unit in accordance with the manufacturer's instructions.

### Heater

- Remove years that do not apply from the type and duplicate label.
- Attach the duplicate label (type label) visibly in the appropriate place in the engine compartment.



### Heater Installation Location

- 1 Heater



Installation location



### Preparing Electrical System

1 Drill out hole to 8.5 mm dia.

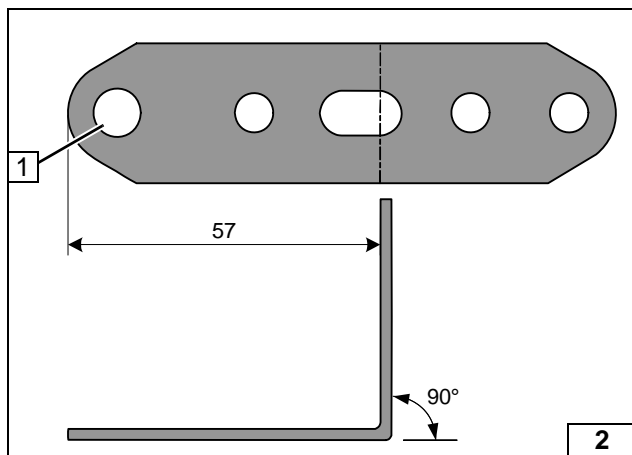

Preparing perforated bracket for engine compartment fuse holder



Connector X7

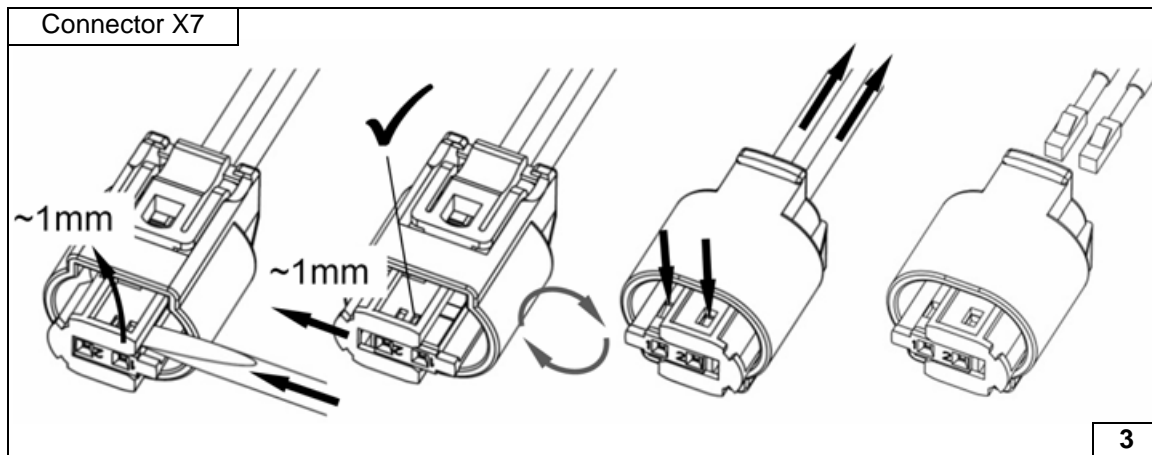

Dismantling metering pump connector



**Electrical System**



**Positive wire**

- 1 Positive wire on positive distributor

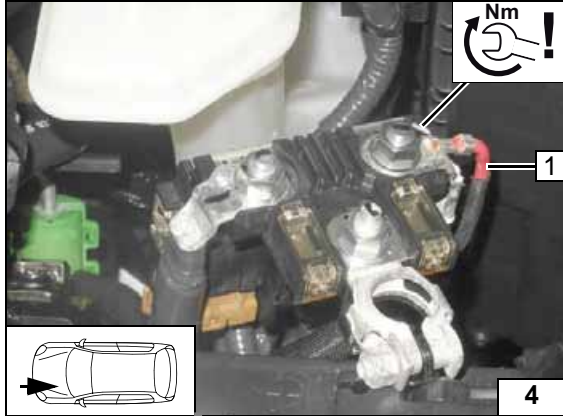

**Wiring harness pass through**

- 1 Protective rubber plug
- 2 Heater wiring harnesses, heater control

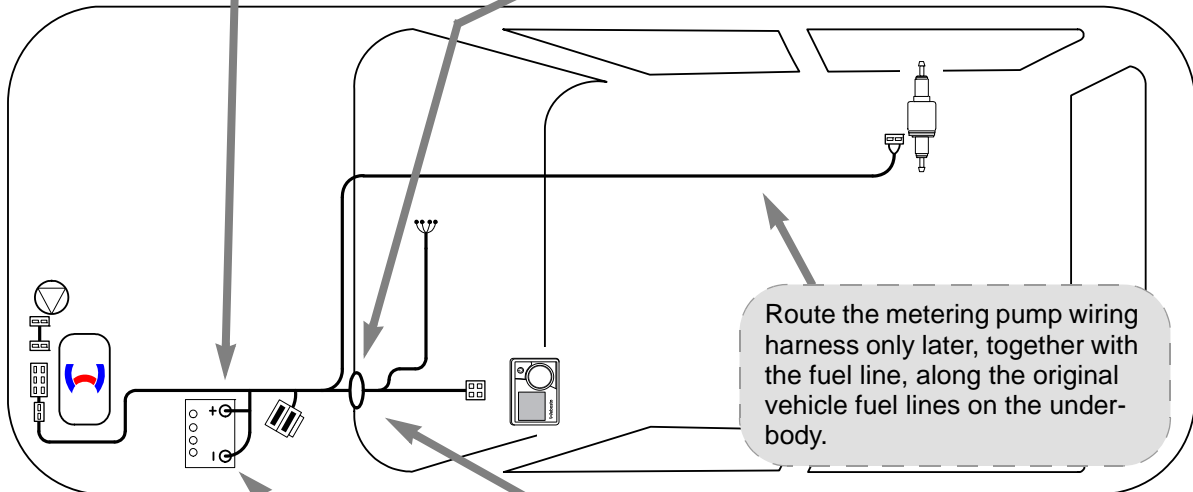
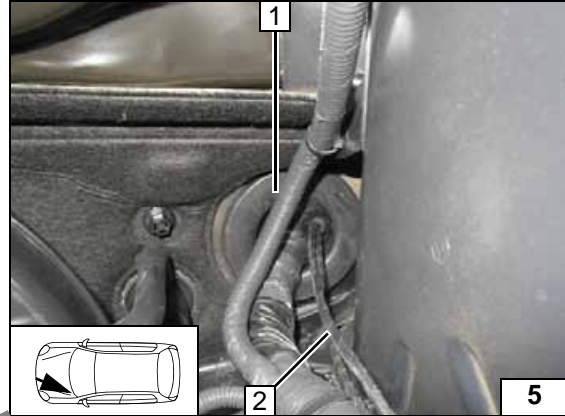

**Wiring harness routing diagram**

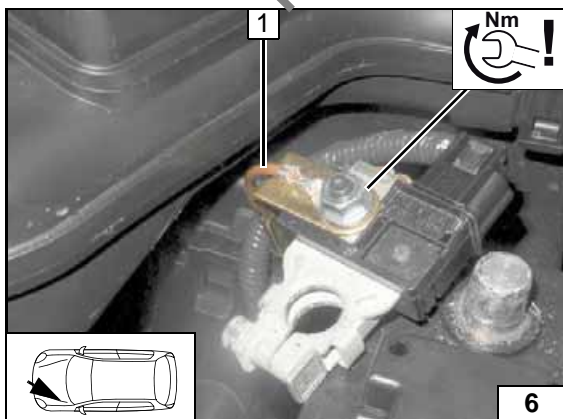

**Earth wire**

- 1 Earth wire on negative battery terminal

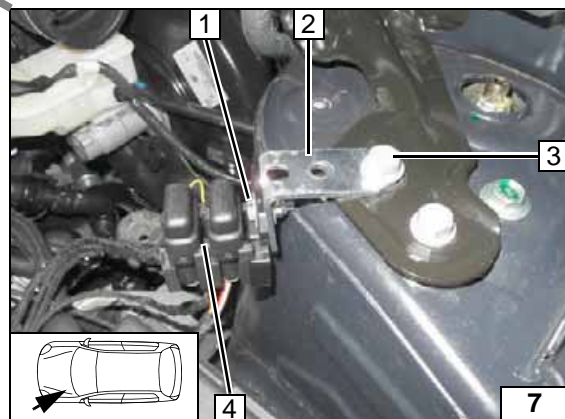

**Engine compartment fuse holder**

- 1 M5x16 bolt, large diameter washer [2x], retaining plate of fuse holder, nut
- 2 Prepared perforated bracket
- 3 Original vehicle bolt
- 4 Fuses F1-2





## Air-Conditioning Control



Integrate the A/C control as explained in the separate installation documentation:

Installation documentation of AC and AAC air-conditioning control for Renault Kadjar '**Standard**'

or

Installation documentation of AAC air-conditioning control for Renault Kadjar '**Comfort**'





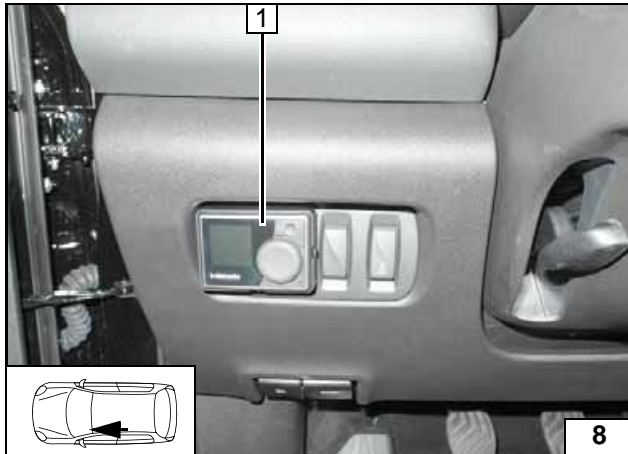
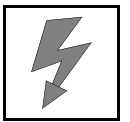

### MultiControl CAR Option

- 1 MultiControl CAR with installation frame



### Installing MultiControl CAR

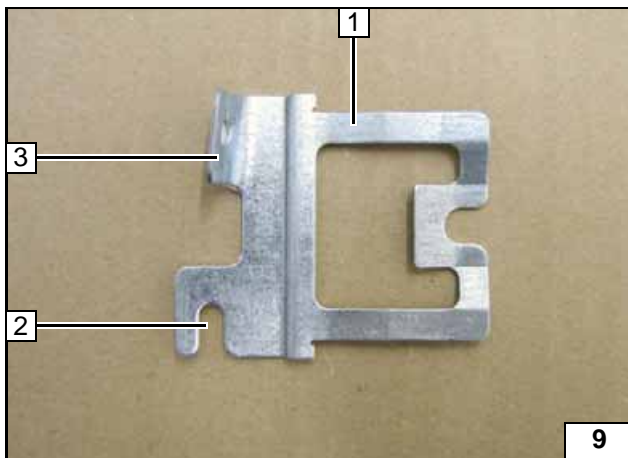

### Remote Option (Telestart)

- 1 Bracket
- 2 Enlarge slot to 6mm
- 3 Bend tab by 90°

### Preparing bracket

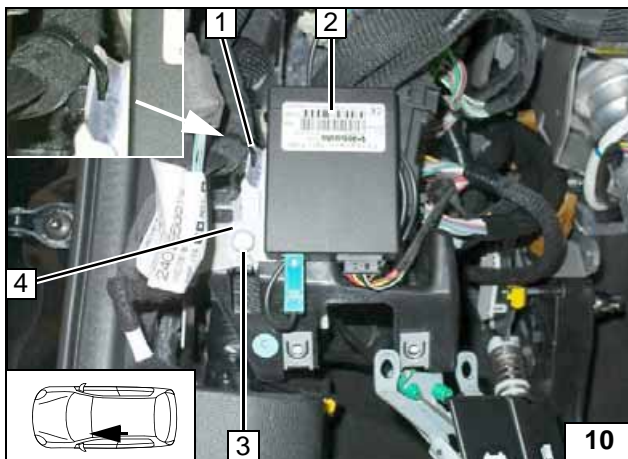

- 1 Cable tie
- 2 Receiver
- 3 Original vehicle bolt
- 4 Bracket



### Installing receiver

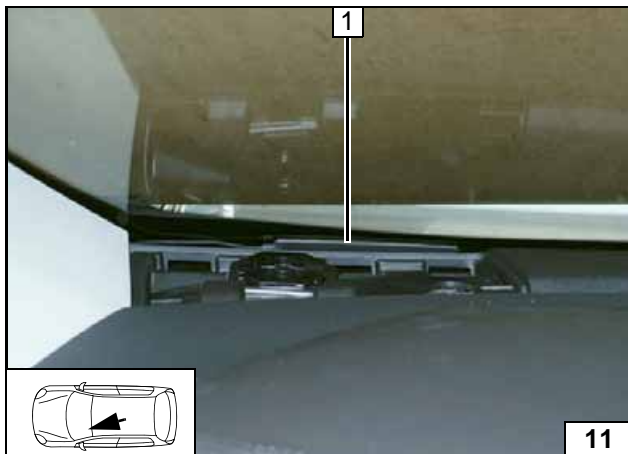

For windcreens with a special coating or heater, use only the area recommended by the manufacturer to assemble aerial.

- 1 Aerial



### Installing aerial

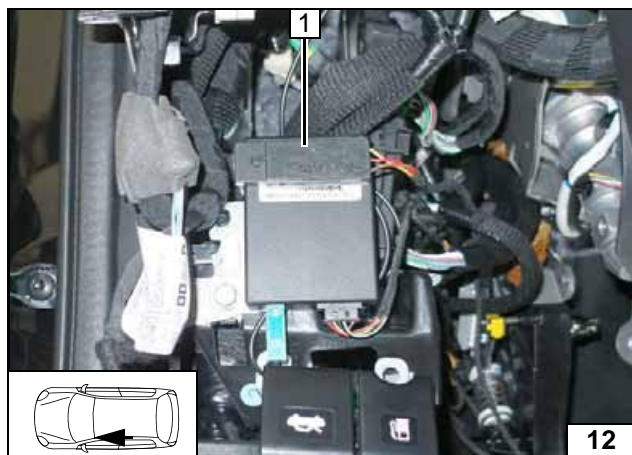

### Temperature sensor T100 HTM

Fasten temperature sensor 1 with double-sided adhesive tape



Installing temperature sensor

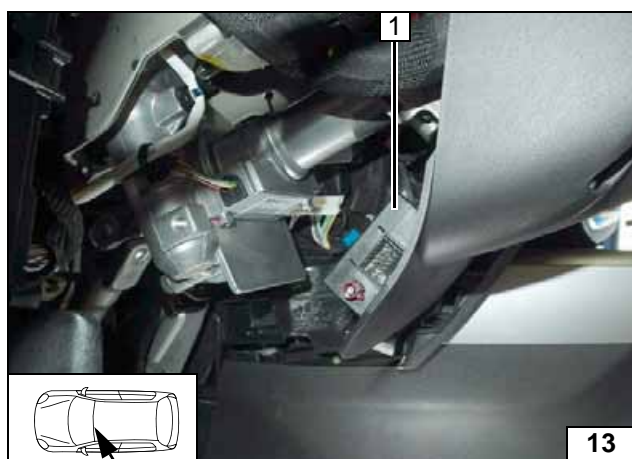

### Thermo Call Option

Secure receiver 1 using double-sided adhesive tape.



Installing receiver

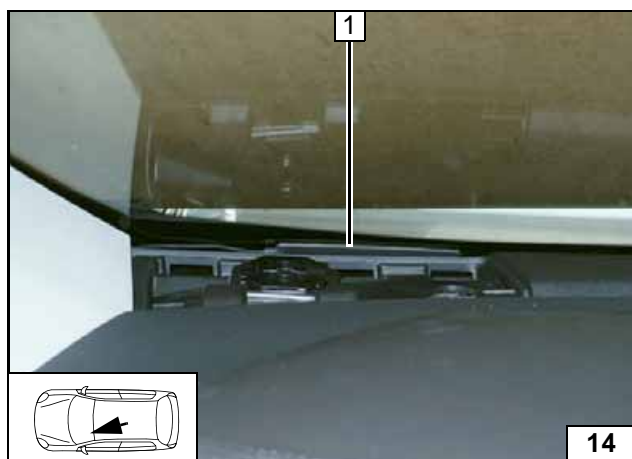

For windscreens with a special coating or heater, use only the area recommended by the manufacturer to assemble aerial.

1 Aerial



Installing aerial

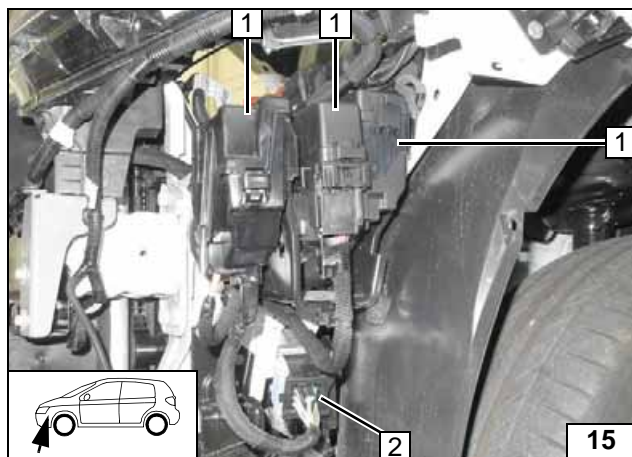
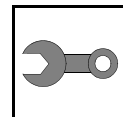

### Preparing Installation Location

Remove relay box 1 [3x] with bracket as well as original vehicle glow plug control element 2 and put aside.



### Preparing installation location

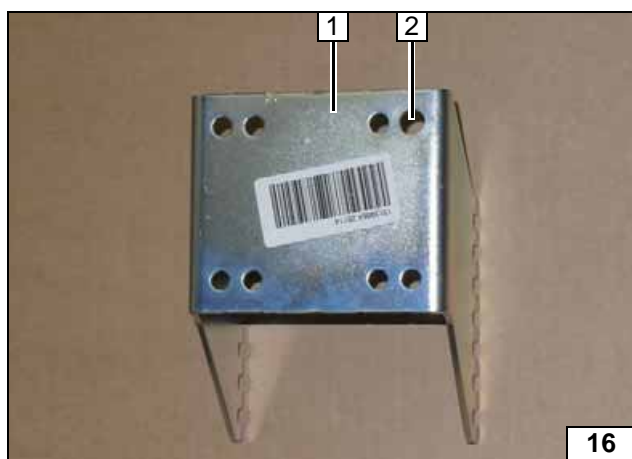

- 1 Bracket
- 2 Drill out hole to 9mm dia.

### Preparing bracket

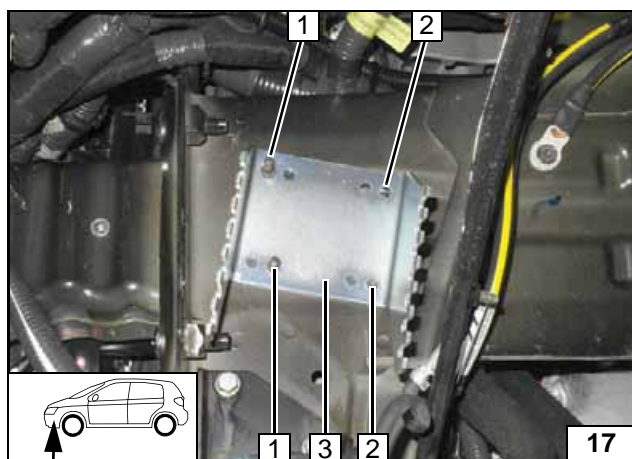

Install bracket 3 on original vehicle stud bolts 1 [2x].

- 2 Copy hole pattern [2x]



### Copying hole pattern

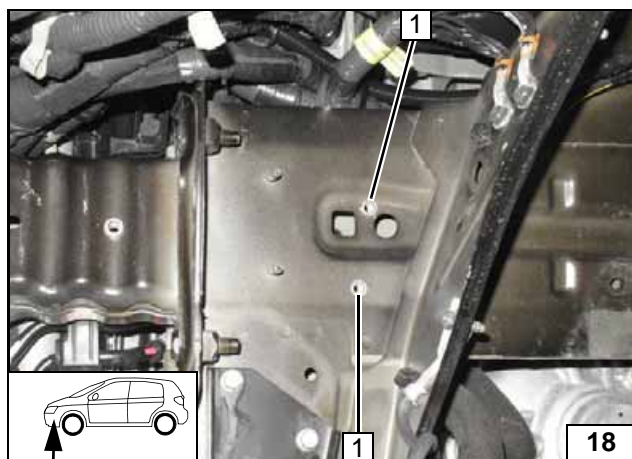

Take off bracket!

- 1 9.1 mm dia. hole, rivet nut [2x each]



### Installing rivet nut



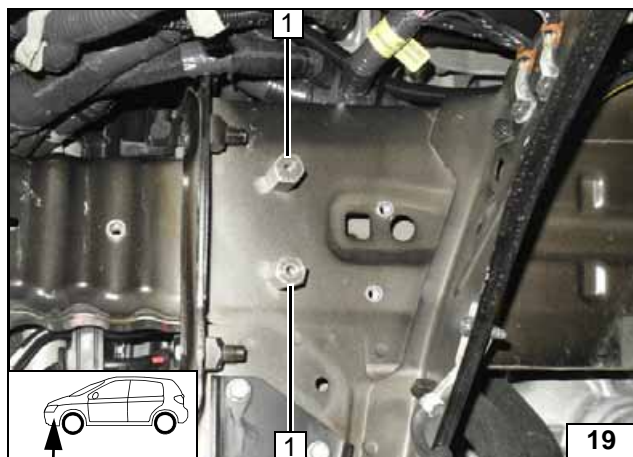
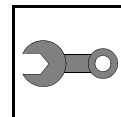

- 1 M6x30 spacer nut [2x] on original vehicle stud bolt

Installing spacer nut

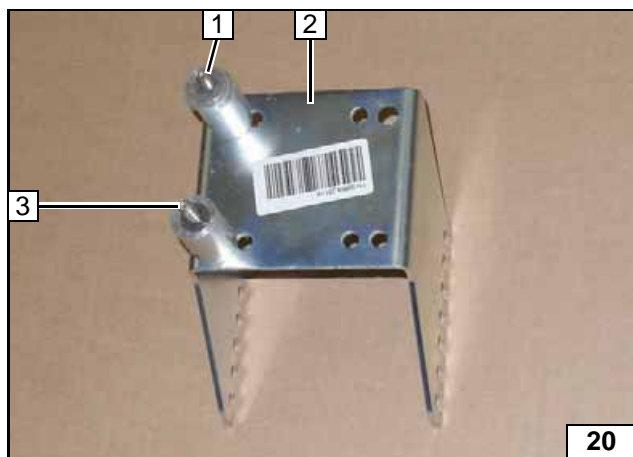

- 1 M6x60 bolt, spring lockwasher, 30mm shim, 5mm shim, pin lock
- 2 Bracket
- 3 M6x60 bolt, spring lockwasher, 30mm shim, pin lock

Premounting bracket

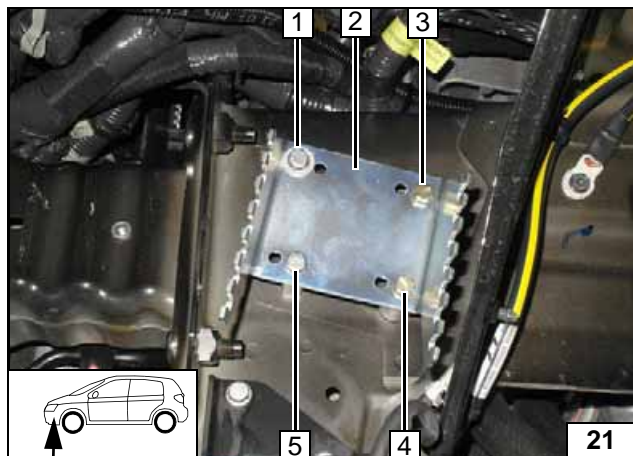

- 1 M6x16 bolt, spring lockwasher, large diameter washer
- 2 Bracket
- 3 M6x60 bolt on rivet nut
- 4 M6x60 bolt on rivet nut
- 5 M6x16 bolt, spring lockwasher

Installing bracket

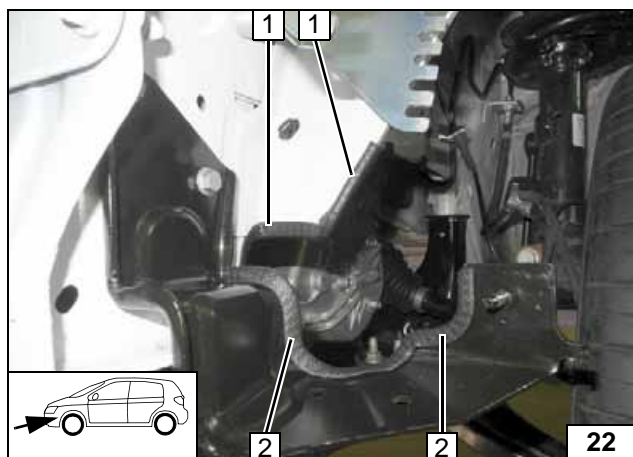

- 1 150 mm edge protection
- 2 200 mm edge protection

Preparing installation area of circulating pump

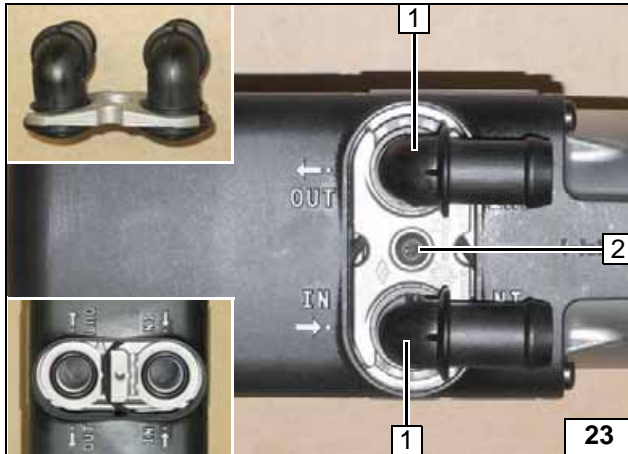
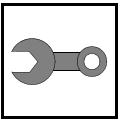

**Preparing Heater**

- 1 Water connection piece, sealing ring [2x each]
- 2 5x15 self-tapping bolt, retaining plate of water connection piece



**Installing water connection piece**

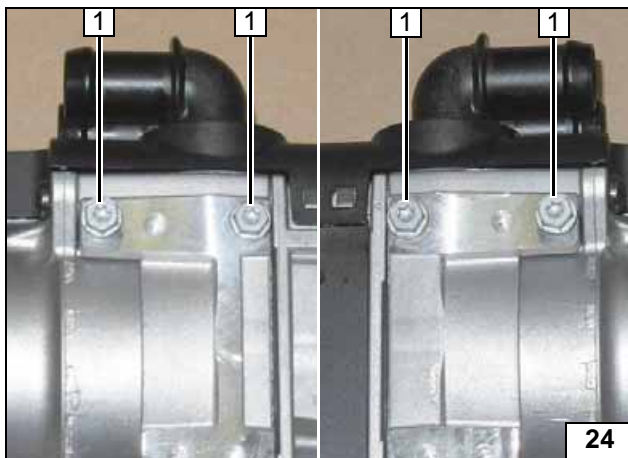

Screw 5x13 self-tapping bolts 1 [4x] into existing holes by a maximum of 3 thread turns.



**Premounting bolts loosely**

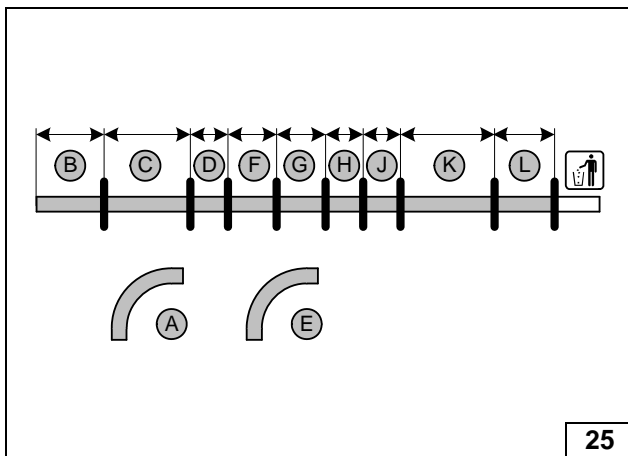

- A = 90°, 18mm dia.
- B = 290
- C = 500
- D = 90
- E = 90°, 18mm dia.
- F = 150
- G = 120
- H = 80
- J = 70
- K = 490
- L = 240

**Cutting hoses to length**

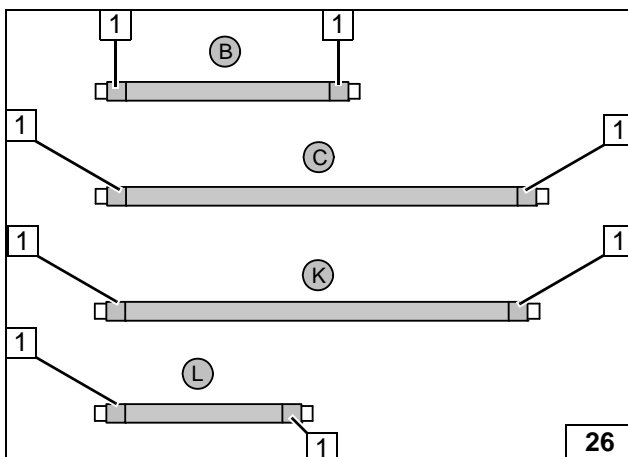

Slide braided protection hoses onto hoses B, C, K and L and cut to length. Cut heat shrink plastic tubing to length.

- 1 Heat shrink plastic tubing, 60 mm long [8x]



**Preparing hoses**

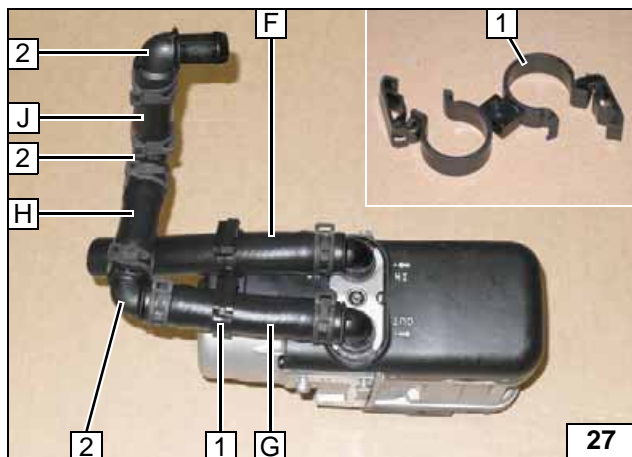
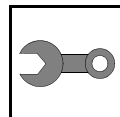

All spring clips = 25 mm dia.

- 1 25x25 hose bracket
- 2 90°, 18x18mm dia. connecting pipe [3x]

Premounting hoses

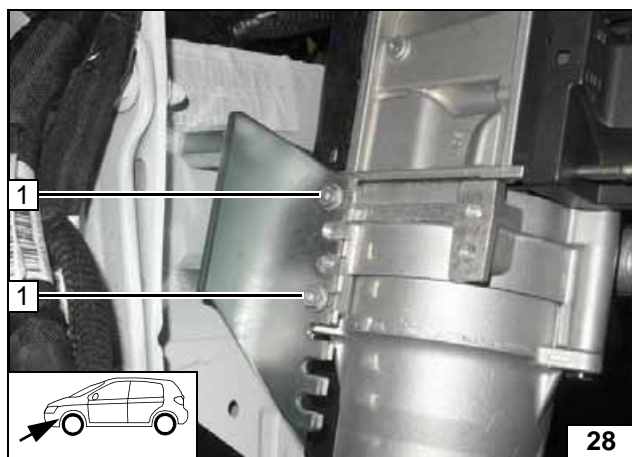

**Installing Heater**

- 1 Tighten 5x13 mm self-tapping bolt [2x]

Installing heater

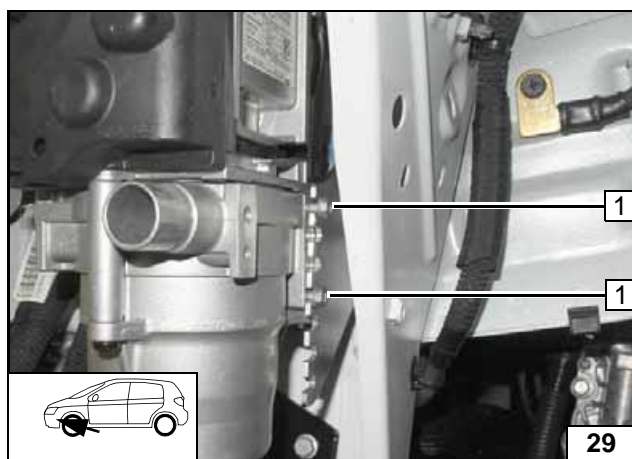

- 1 Tighten 5x13 mm self-tapping bolt [2x]

Installing heater

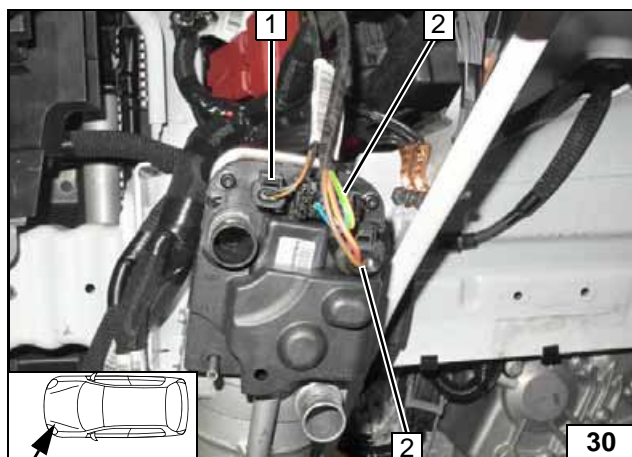

- 1 Connector of circulating pump wiring harness
- 2 Heater wiring harness connector [2x]

Installing wiring harnesses

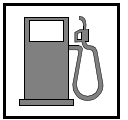

**Fuel**



Open the vehicle's fuel tank cap, ventilate the tank and then re-close the tank lock.

Catch any fuel running off in an appropriate container.



Route fuel line and metering pump wiring harness so that they are protected against stone impact. Unless specified otherwise, always fasten using cable ties.

Provide rub protection for fuel line and wiring harness in areas where there are sharp edges.

The fuel line and wiring harness are routed to the metering pump as shown in the wiring harness routing diagram.

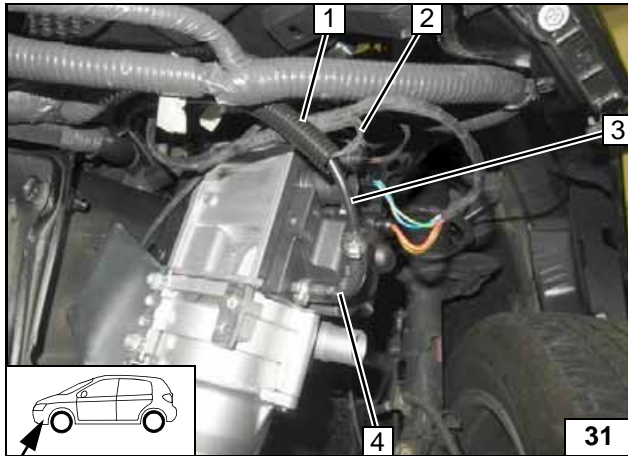

Route fuel line **3** and metering pump wiring harness **2** in 10mm dia. corrugated tube **1** in the engine compartment.

**4** 90° moulded hose, 10 mm dia. clamp [2x]

**Connect-  
ing heater**

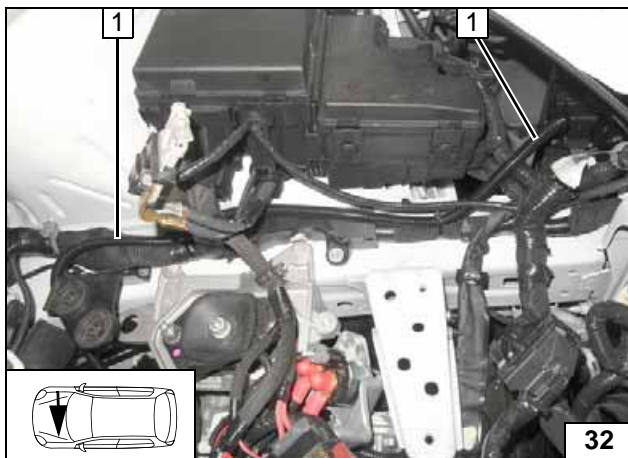

Route fuel line and metering pump wiring harness in 10mm dia. corrugated tube **1** to the firewall and further along the original vehicle lines to the underbody.



**Routing  
lines**

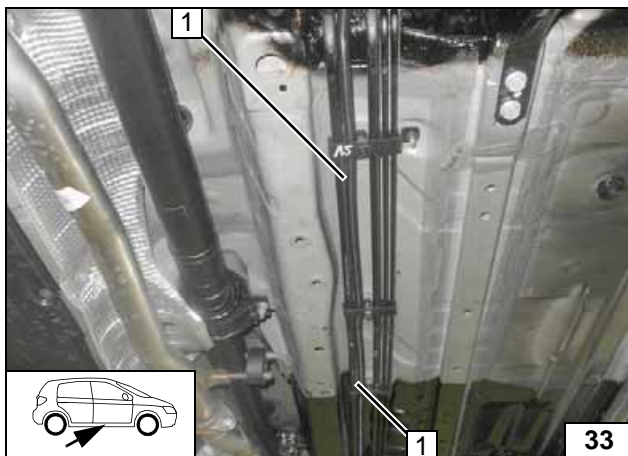

Route fuel line and metering pump wiring harness in 10mm dia. corrugated tube **1** on original vehicle lines to the installation location of the metering pump.



**Routing  
lines**



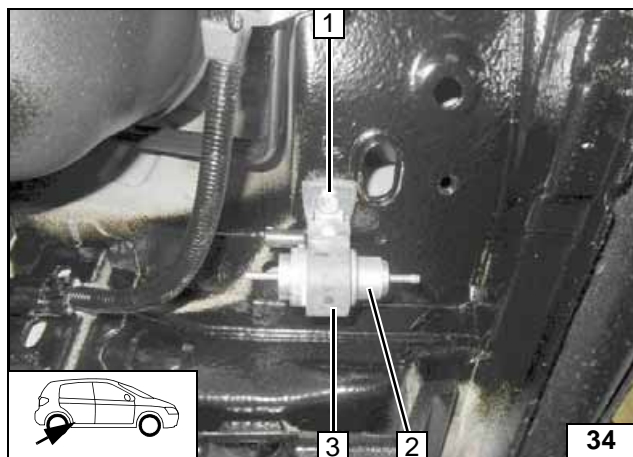

- 1 M6x25 bolt, support angle bracket, original vehicle threaded hole
- 2 Metering pump
- 3 Metering pump mount



**Installing metering pump**

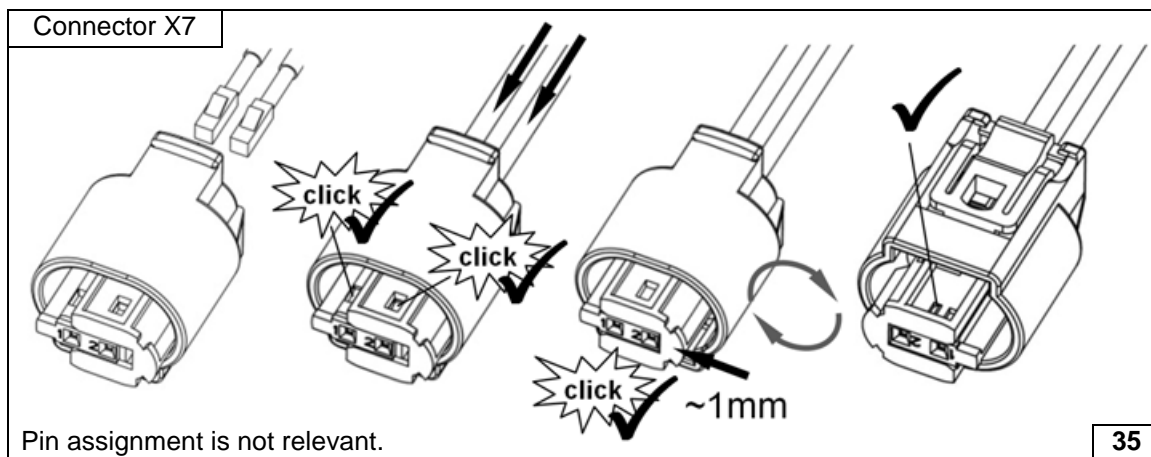

**Completing metering pump connector**

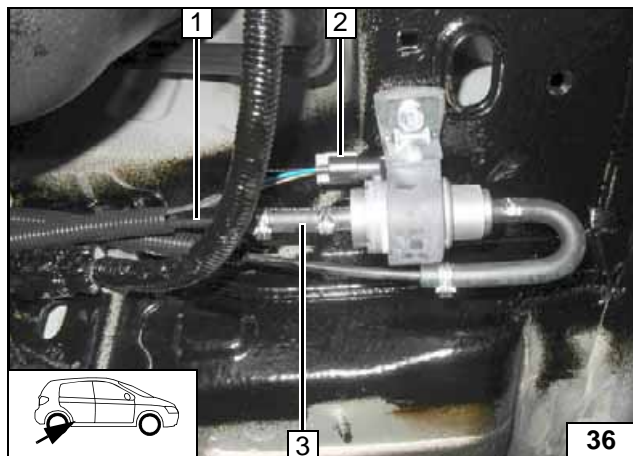

- 1 Fuel line of heater
- 2 Wiring harness of metering pump, connector X7 mounted
- 3 Hose section, 10mm dia. clamp [2x]



**Connecting metering pump**

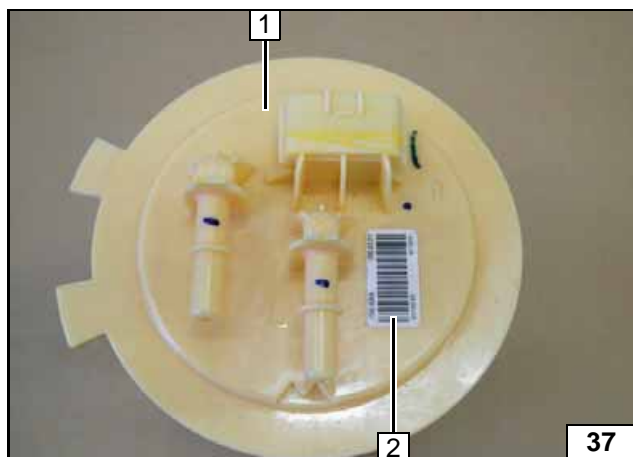

Remove the fuel tank sending unit 1 according to the manufacturer's instructions. Detach sticker 2 and reattach as shown in the next figure.



**Fuel extraction**



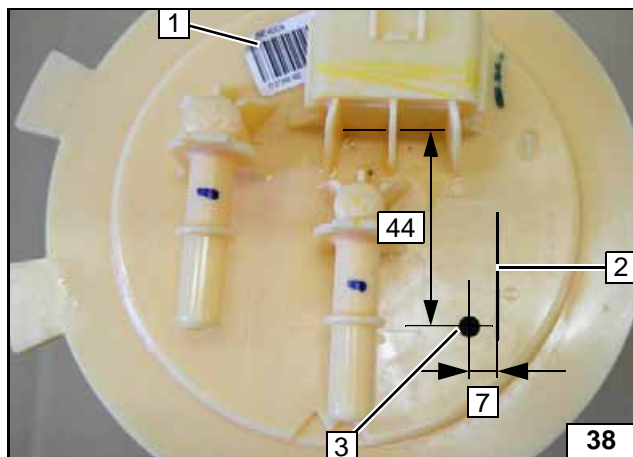
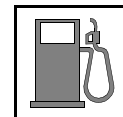

- 1 Sticker, moved
- 2 Existing formed ridge
- 3 Copy hole pattern, 6 mm dia. hole



**Fuel extraction**

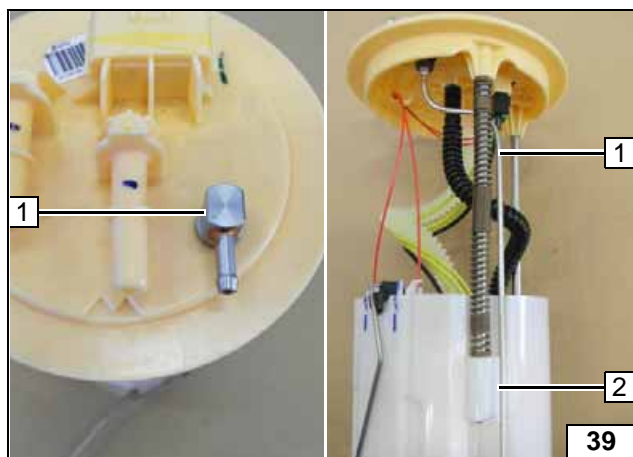

Bend fuel standpipe 1 according to template and cut to length.  
Engage fuel standpipe 1 in existing groove at position 2.



**Installing fuel standpipe**

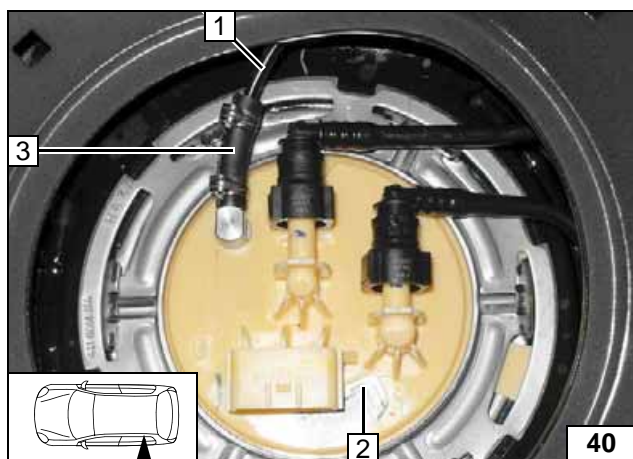

Install fuel tank sending unit 2 and connect in accordance with manufacturer's instructions.

- 1 Fuel line
- 3 Hose section, 10mm dia. clamp [2x]



**Connecting fuel line**

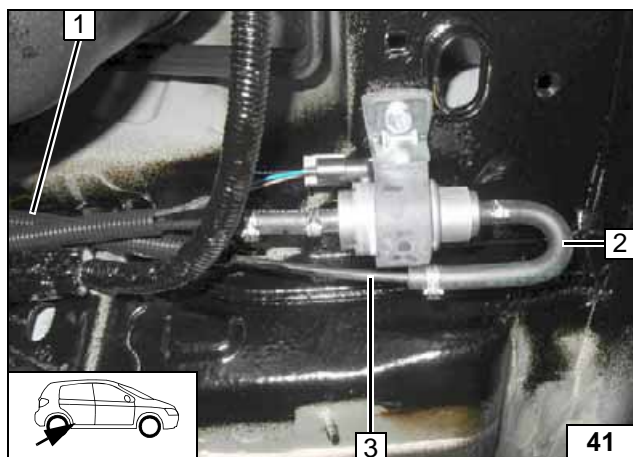

Slide 10mm dia. corrugated tube 1 onto fuel line of fuel standpipe 3.  
Ensure sufficient distance from neighbouring components, correct if necessary.

- 2 180° moulded hose, 10 mm dia. clamp [2x]



**Connecting metering pump**



### Coolant Circuit





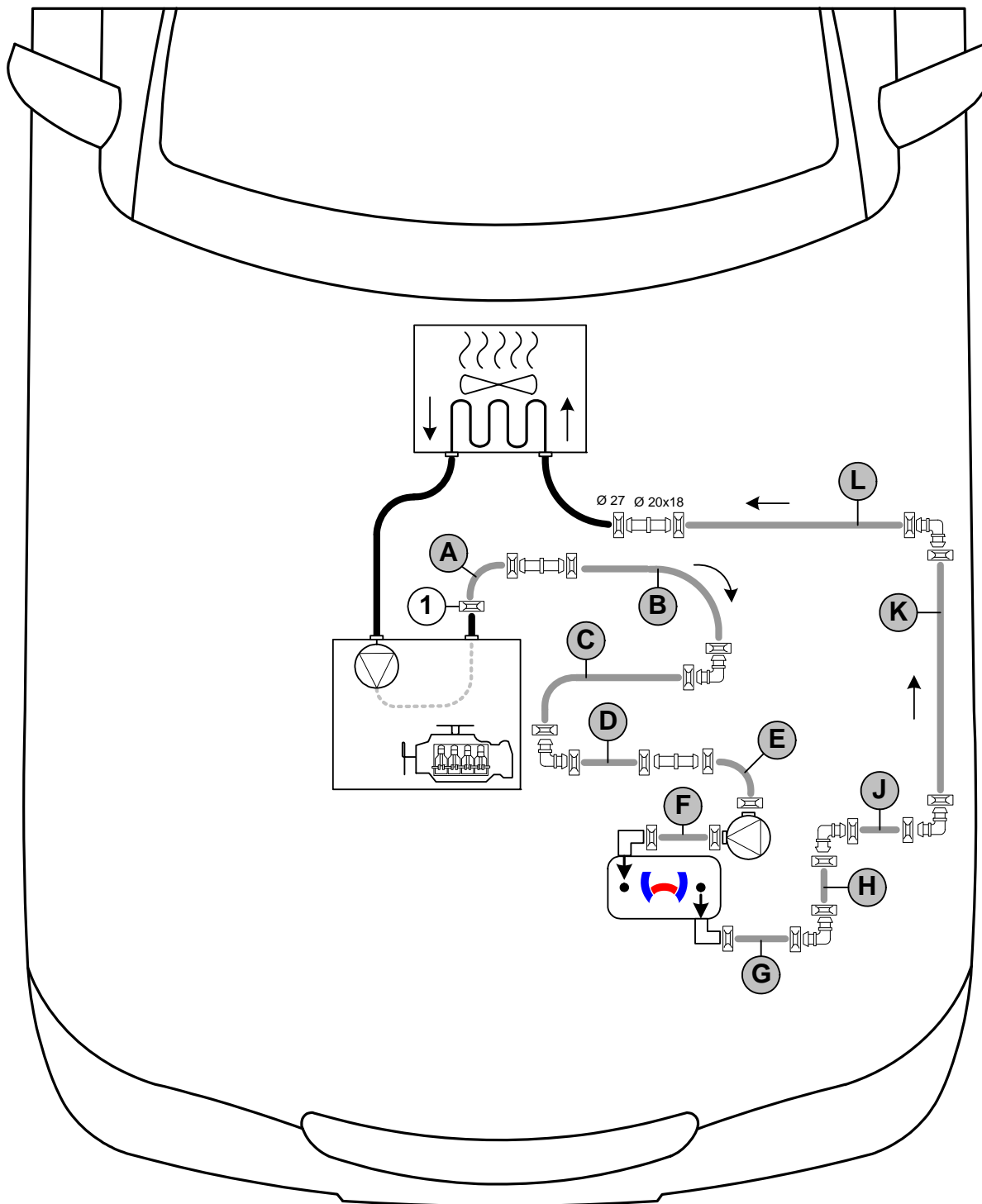

Any coolant running off should be collected in an appropriate container. Route hoses kink-free. Unless specified otherwise, always fasten using cable ties. Position clamps so that other hoses cannot be damaged. The heater must be filled with coolant when installing the hoses.

The connection should be modelled on an 'inline' circuit and based on the following diagram:



Hose routing diagram

All spring clips without a specific designation  = 25 mm dia.  
 All connecting pipes without a specific designation  and  = 18x18mm dia.  
 1 = Original vehicle spring clip .



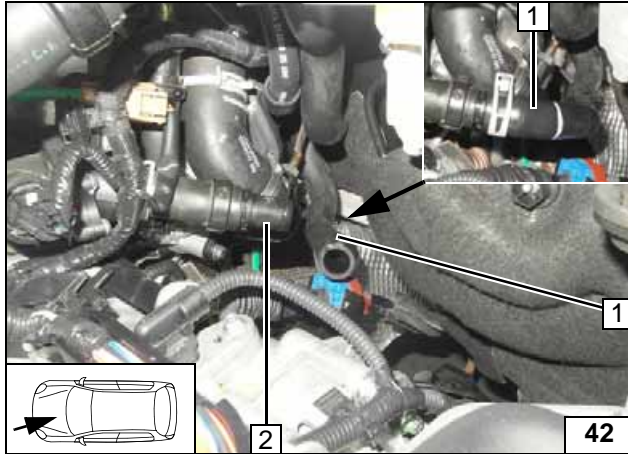

Pull hose of engine outlet / heat exchanger inlet **1** off connection piece of engine outlet **2**. Original vehicle spring clip will be reused.

**Cutting point**

**1** Original vehicle spring clip

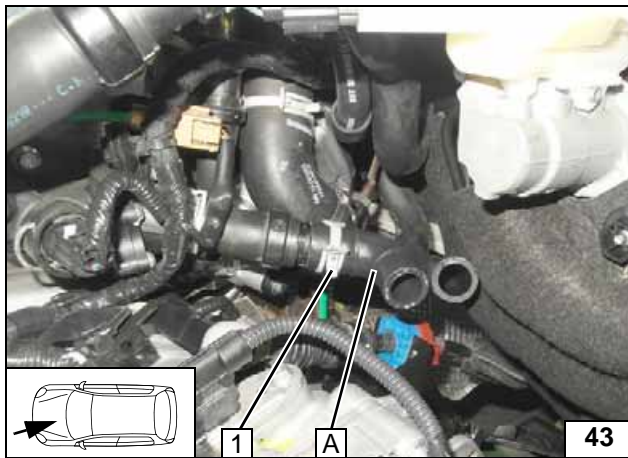

**Connect-  
ing engine  
outlet**

**1** Clip-type cable tie [3x]

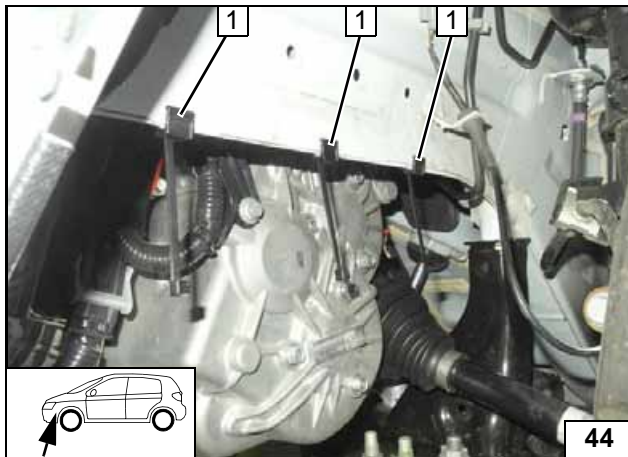

**Fastening  
clip-type  
cable tie**

**1** Drill out hole to 8.5 mm dia.

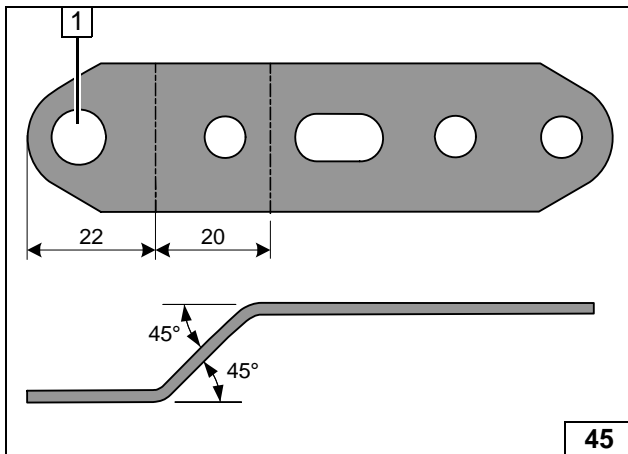

**Preparing per-  
forated brack-  
et for hose  
fastening**

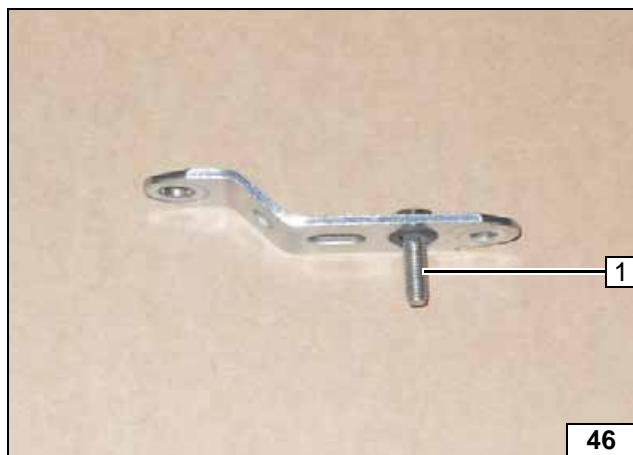
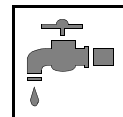

1 M6x20 bolt, pin lock

Premounting perforated bracket

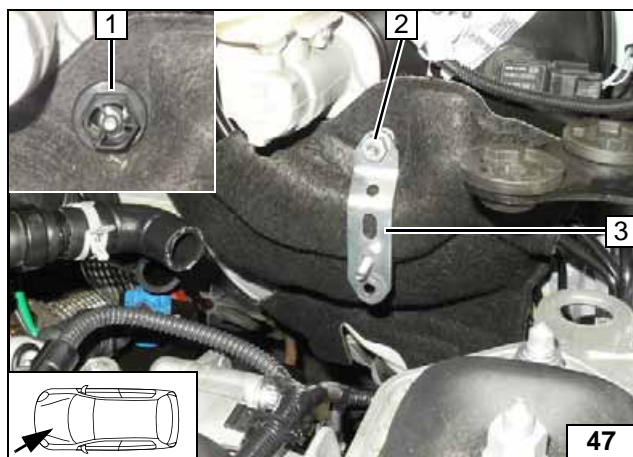

1 Remove original vehicle nut  
2 Loosely mount M8 flanged nut  
3 Perforated bracket

Loosely installing perforated bracket

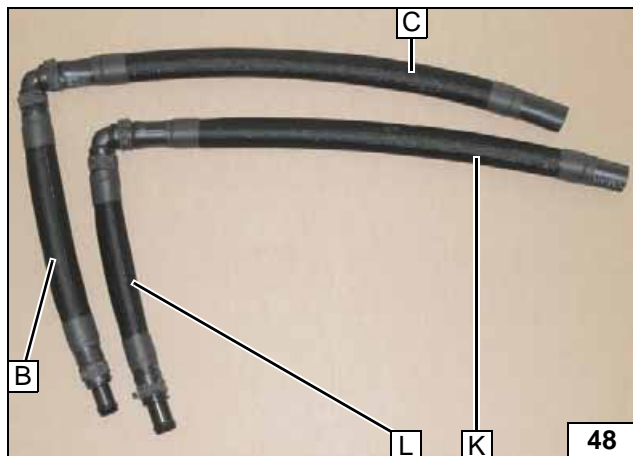

Premounting hoses

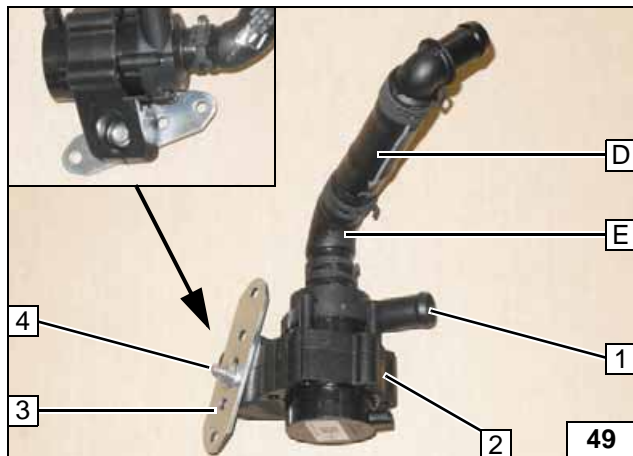

1 Circulating pump  
2 Circulating pump mount  
3 Perforated bracket  
4 M6x25 bolt, flanged nut

Premounting circulating pump



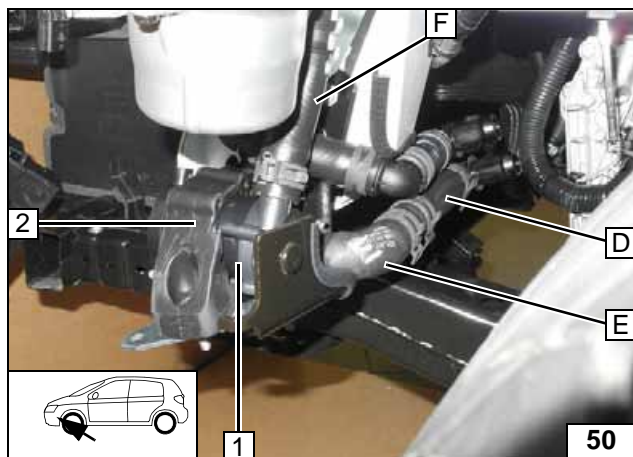

- 1 Circulating pump
- 2 Circulating pump mount

**Installing circulating pump**

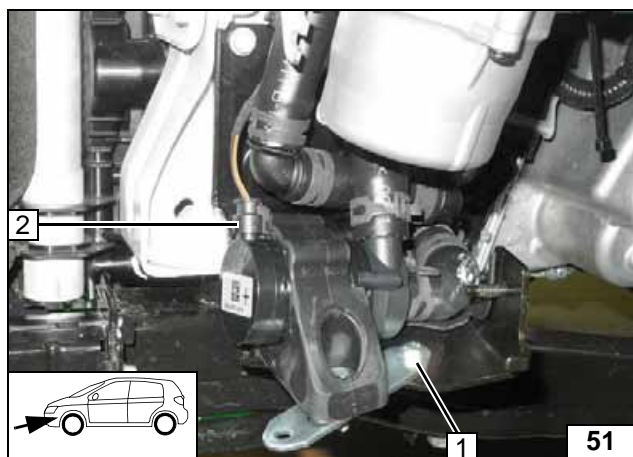

- 1 M6x20 bolt, original vehicle hole, flanged nut
- 2 Connector of circulating pump wiring harness

**Installing circulating pump**

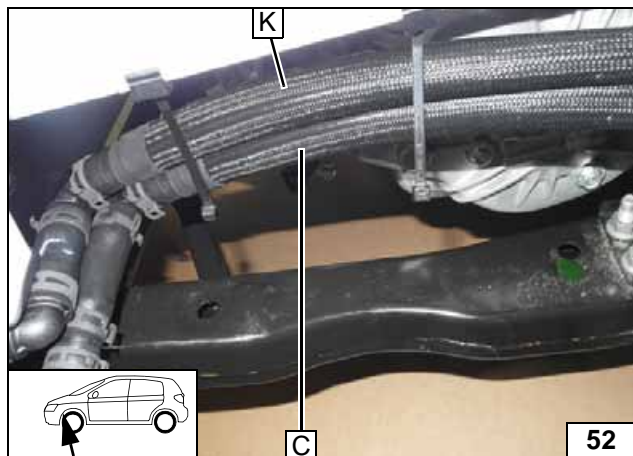

**Connection of pre-mounted hoses**

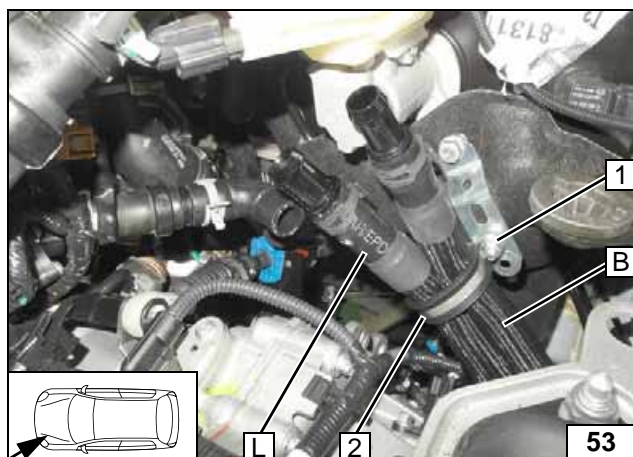

Route hoses **B** and **L** upwards in the engine compartment. Install 38mm dia. rubber-coated p-clamp **2**.

- 1 Loosely mount M6 flanged nut



**Routing of pre-mounted hoses**

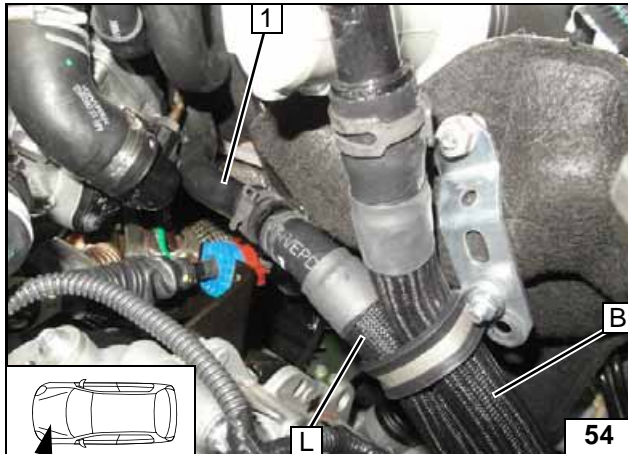

1 Hose section on heat exchanger inlet

Connect-  
ing heat ex-  
changer  
inlet

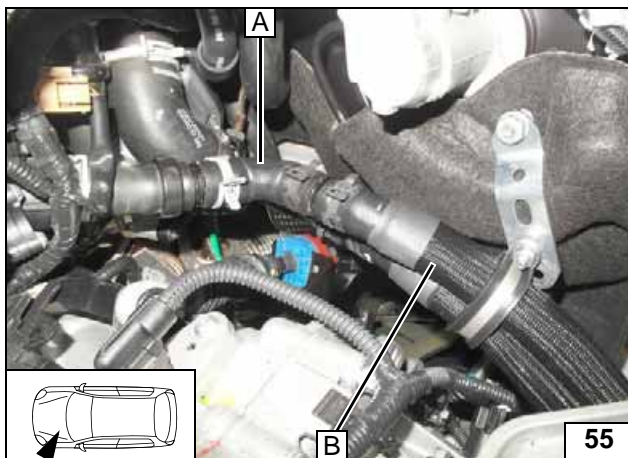

Connect-  
ing engine  
outlet

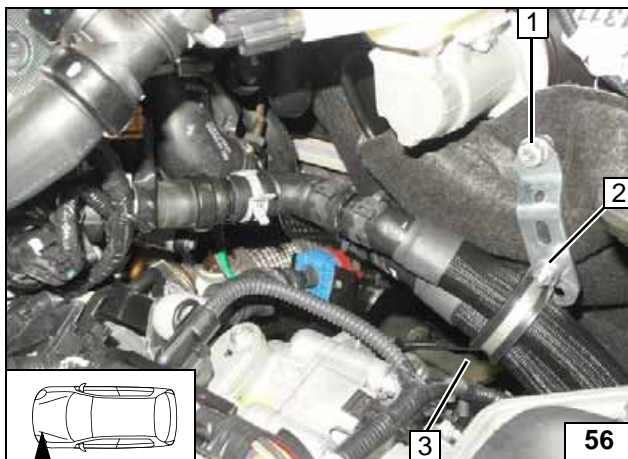

Align hoses. Tighten M8 flanged nut 1 and M6 flanged nut 2. Ensure sufficient distance from transmission at position 3, correct if necessary.



Aligning  
hoses

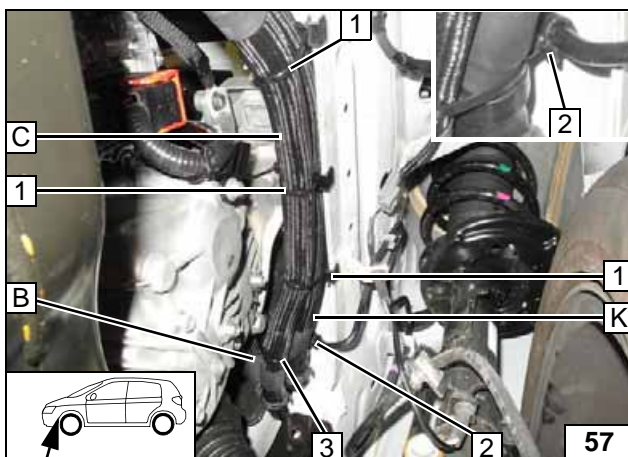

Close clip-type cable tie 1 [3x] around hoses C and K .

- 2 8x25 hose bracket between hose K and original vehicle brake line
- 3 Cable tie



Aligning  
hoses

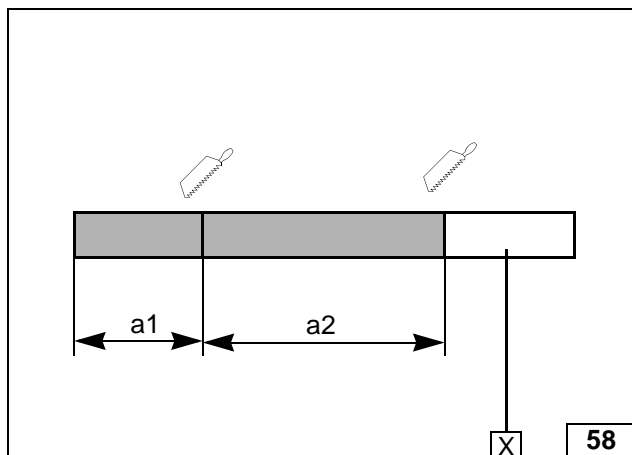
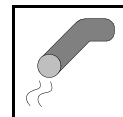

**Exhaust Gas**

a1 = 140

a2 = 300

X =

Preparing exhaust pipe

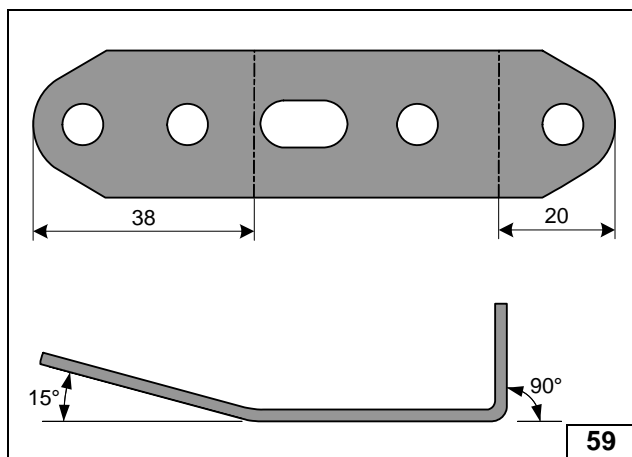

Preparing perforated bracket

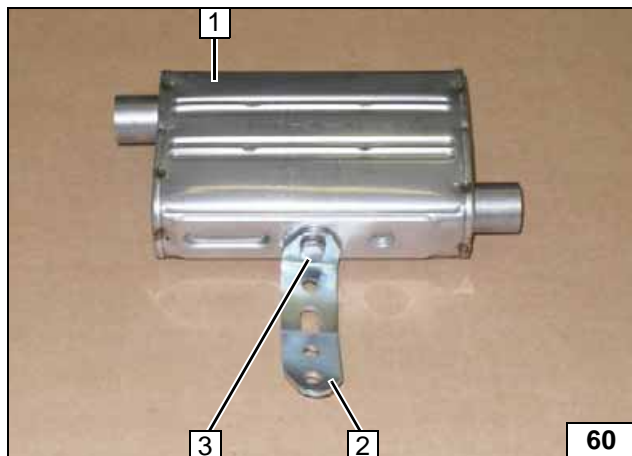

- 1 Silencer
- 2 Perforated bracket
- 3 M6x16 bolt, spring lockwasher

Premounting silencer

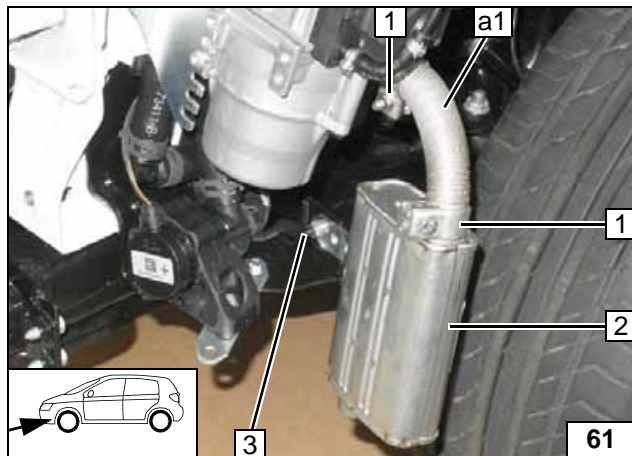

- 1 Hose clamp [2x]
- 2 Silencer
- 3 M6 flanged nut on original vehicle stud bolt

Installing exhaust pipe a1 / silencer



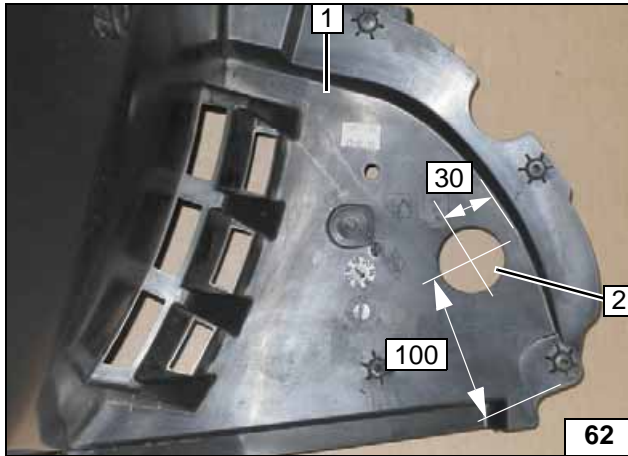
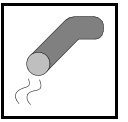

- 1 Wheel well trim
- 2 Hole (as per work step 1 of the installation instructions)



Hole in wheel well trim

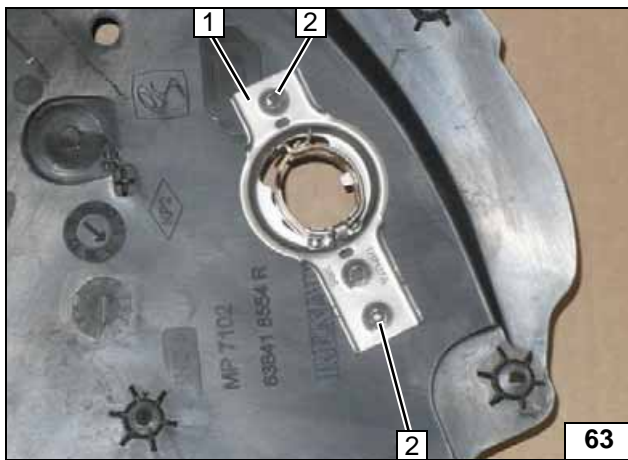

Position exhaust end fastener 1 as per work step 3 of the installation instructions and copy hole pattern 2 [2x].



Copying hole pattern



Hole 1 [2x] as per work step 4 of the installation instructions.



Holes in wheel well trim

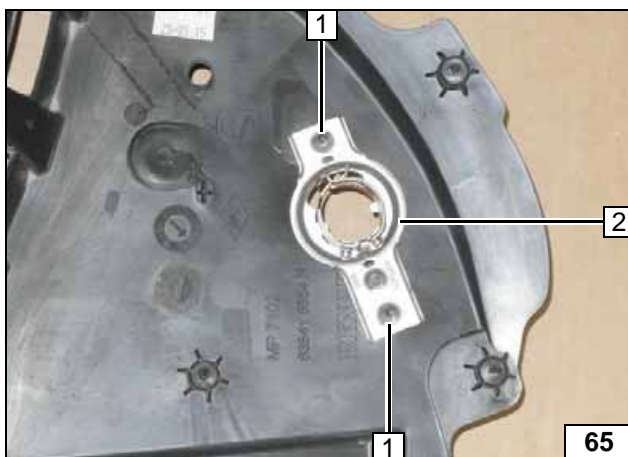

- 1 5x13 self-tapping screw [2x] as per work step 5 of the installation instructions
- 2 Exhaust end fastener

Installing exhaust end fastener



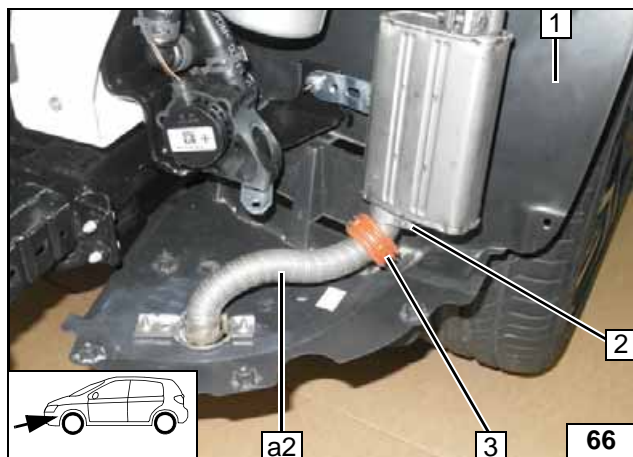
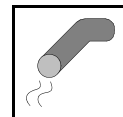

Mount wheel well trim **1**. Install exhaust pipe **a2** as per work steps 6 - 8 of the installation instructions.

- 2** Hose clamp
- 3** Spacer bracket

**Installing wheel well trim / exhaust pipe a2**

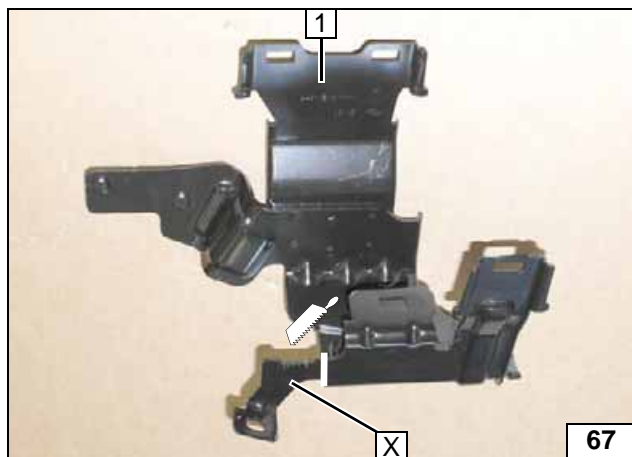
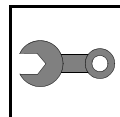

### Installing Relay Box

1 Relay box bracket

X =

Preparing bracket of relay box

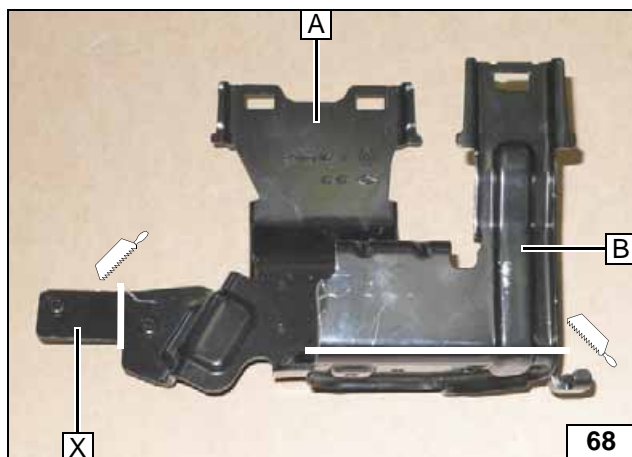

A Bracket section will be re-used  
B Bracket section will be re-used

X =

Cutting bracket

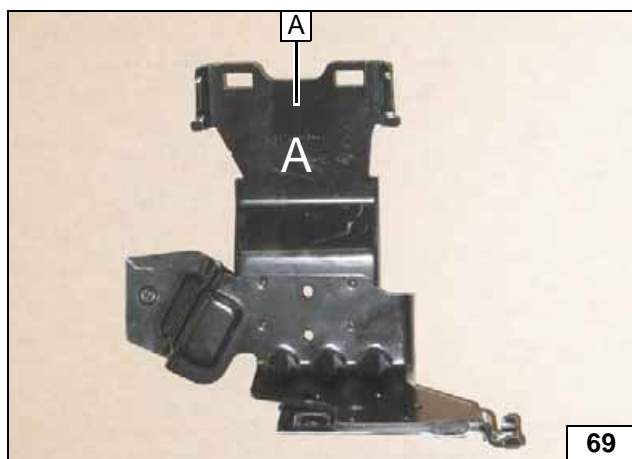

Identify bracket section A.



View of bracket section A

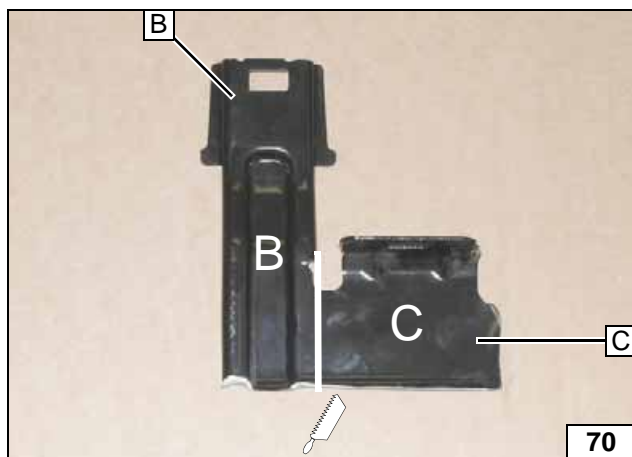

Identify bracket sections B and C.

B Bracket section will be re-used  
C Bracket section will be re-used



Cutting bracket

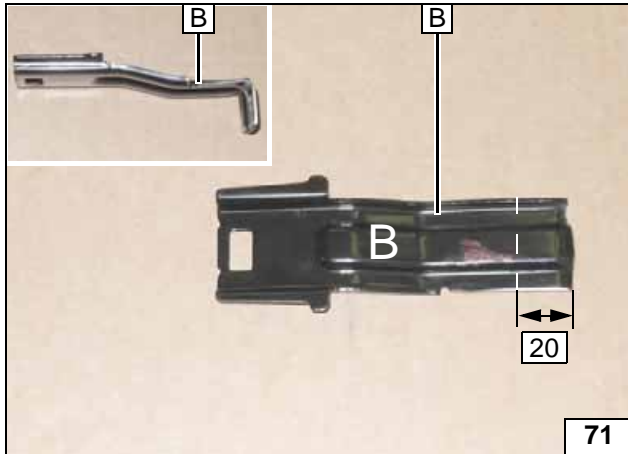
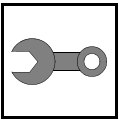

Bending  
bracket  
section B

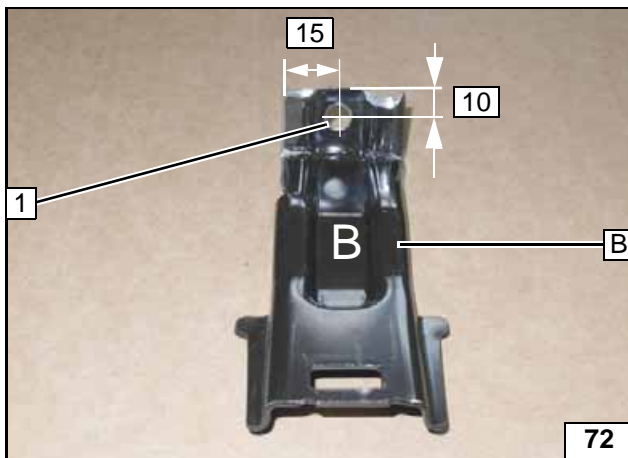

1 7 mm dia. hole



Apply anti-corrosion agent on bracket section B.

Hole in  
bracket  
section B

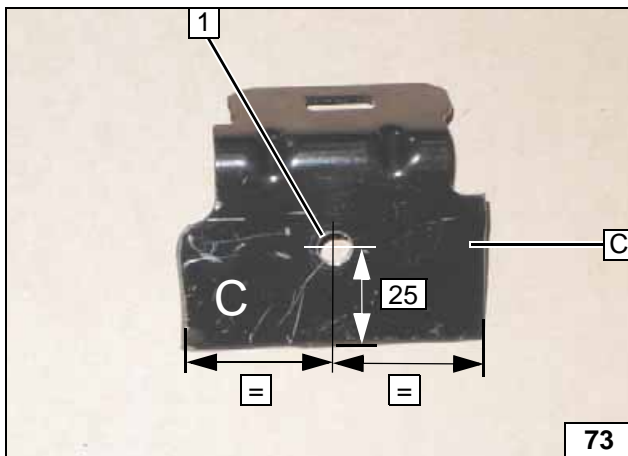

1 7 mm dia. hole

Hole in  
bracket  
section C

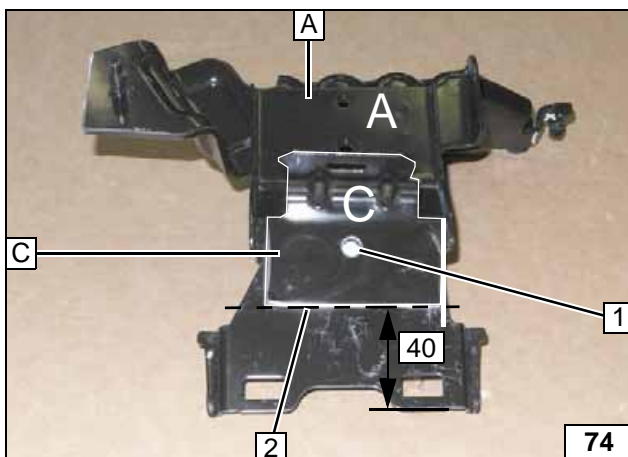

Position bracket section C at guide line 2 as shown. Copy hole pattern 1.



Apply anti-corrosion agent on bracket sections A and C.

Premounting  
bracket sections A and C

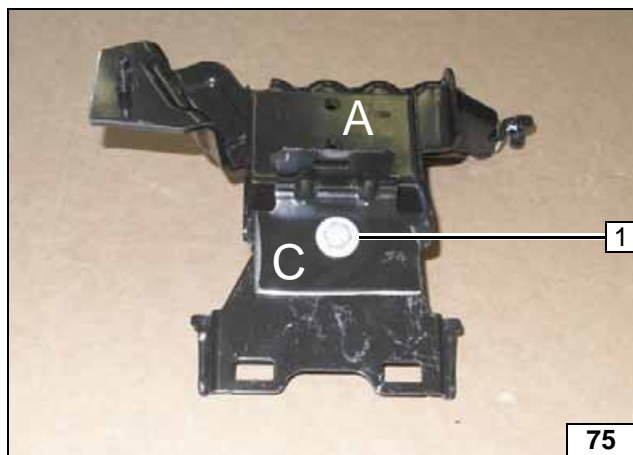
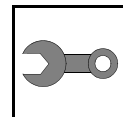

- 1 M6x12 bolt, flanged nut, large diameter washer

Premounting bracket sections A and C

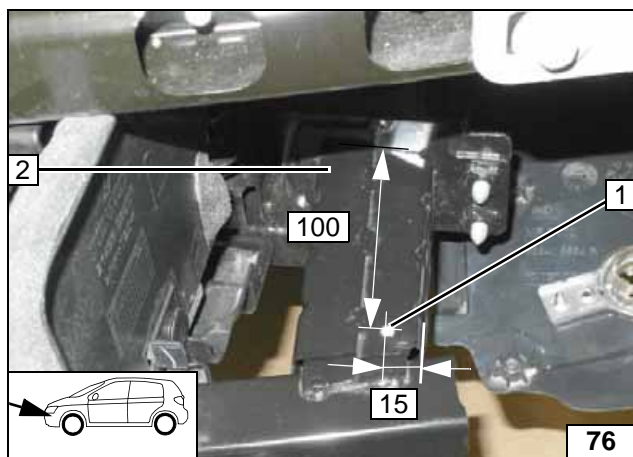

- 1 9.1mm dia. hole
- 2 Impact absorber

Preparing installation area of relay box

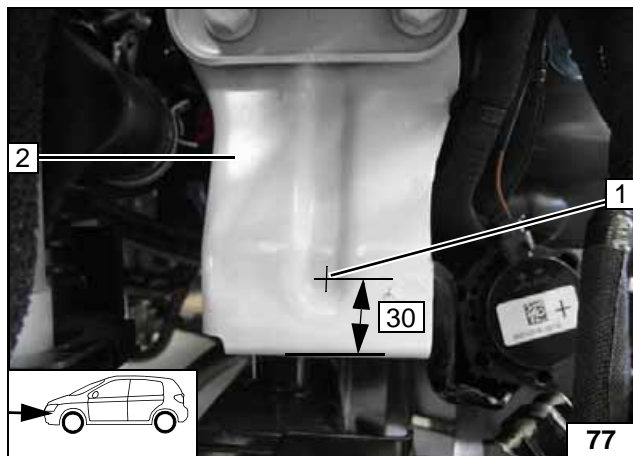

- 1 9.1mm dia. hole
- 2 Frame side member

Preparing installation area of relay box

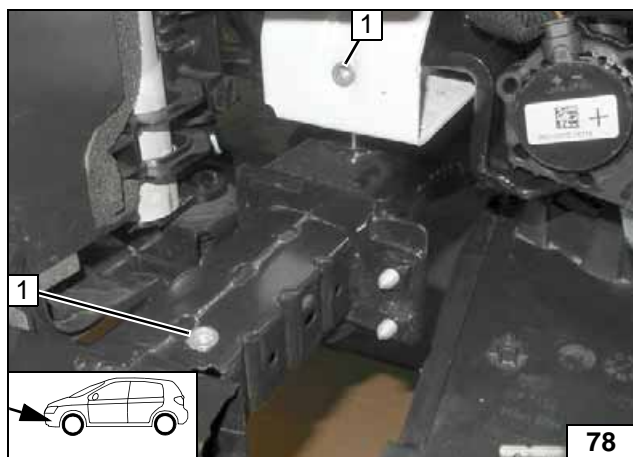

- 1 Insert rivet nut [2x]

Preparing installation area of relay box

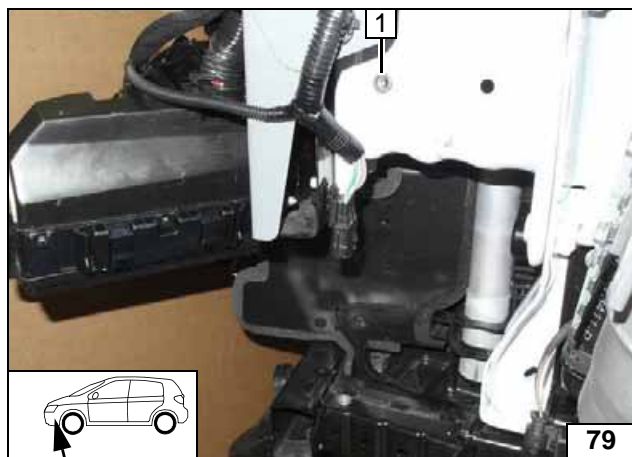
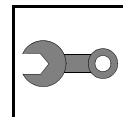

1 Rivet nut, existing hole

Inserting rivet nut for bracket section A

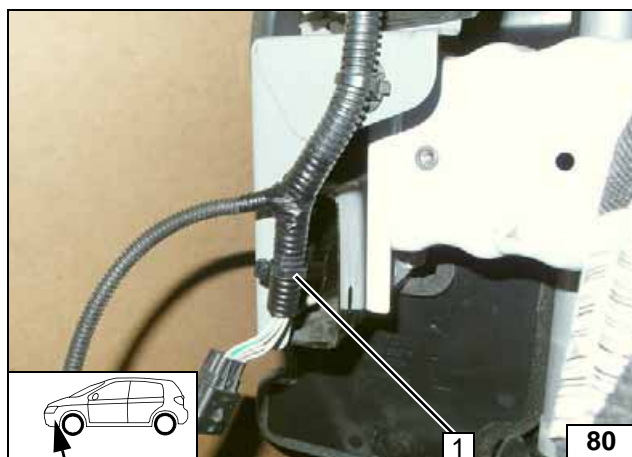

1 Clip-type cable tie

Fastening original vehicle connector to bumper

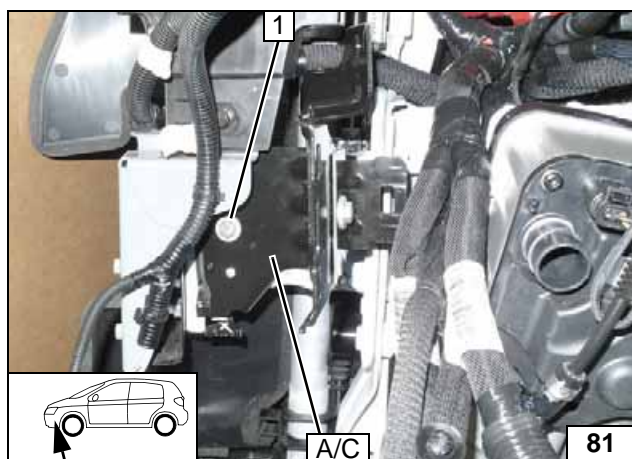

1 M6x20 bolt, spring lockwasher, large diameter washer

Installing bracket section A/C

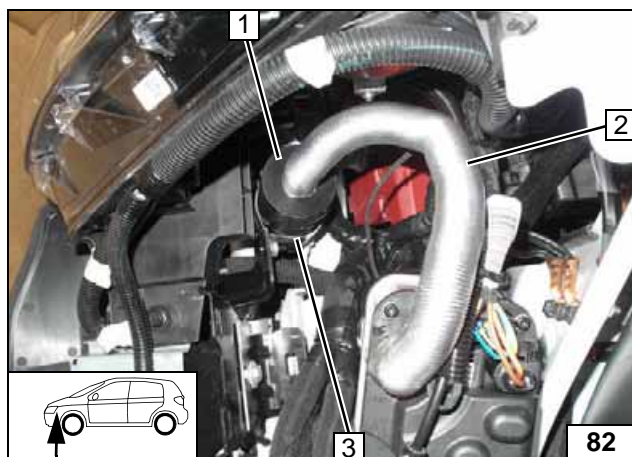

1 Silencer  
2 Combustion air pipe  
3 52 mm dia. clamp



Installing combustion air pipe



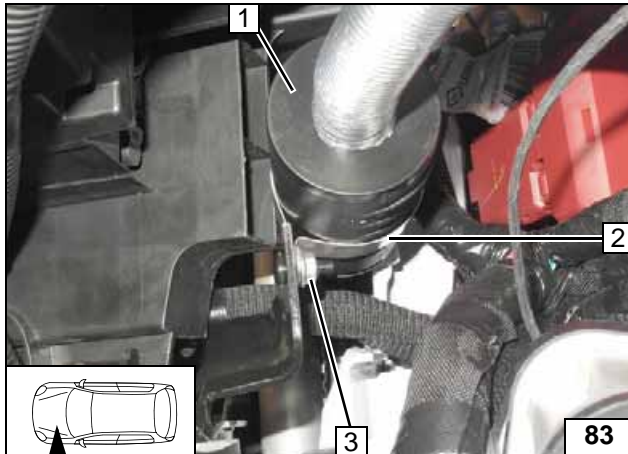
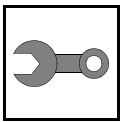

- 1 Silencer
- 2 52 mm dia. clamp
- 3 Stud bolt on original vehicle bracket  
A, M6 flanged nut

**Installing silencer**

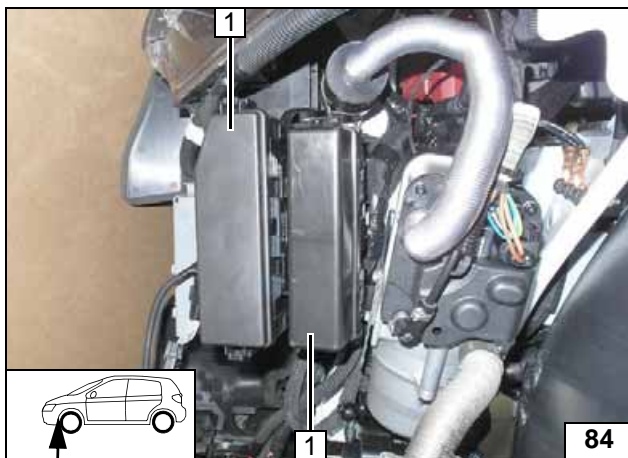

- 1 Relay box [2x]

**Installing relay box onto bracket section A/C**

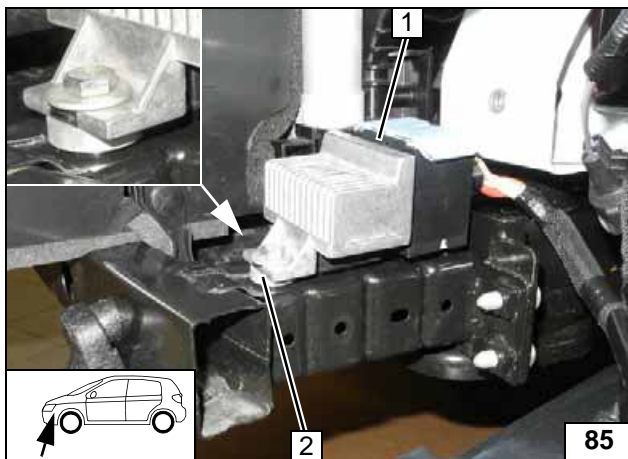

- 1 Original vehicle glow plug control element
- 2 M6x35 bolt, spring lockwasher, large diameter washer, 10mm shim

**Installing original vehicle control element**

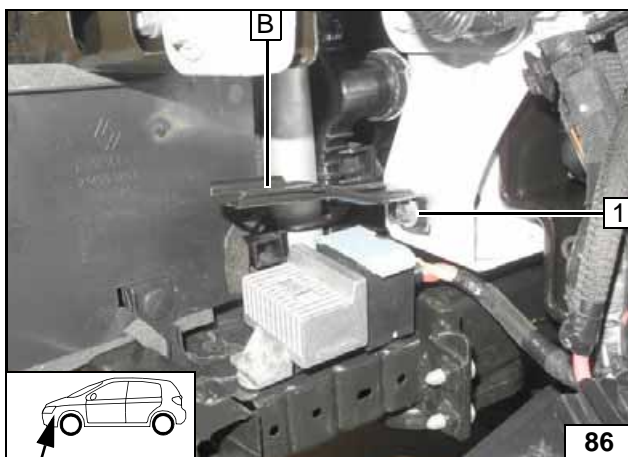

- 1 M6x35 bolt, spring lockwasher, large diameter washer, 5mm shim

**Installing bracket section B**

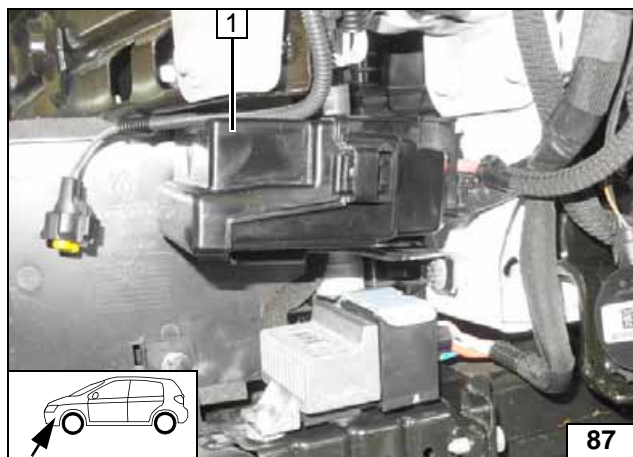
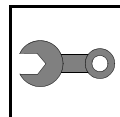

1 Relay box

Installing re-  
lay box onto  
bracket sec-  
tion B

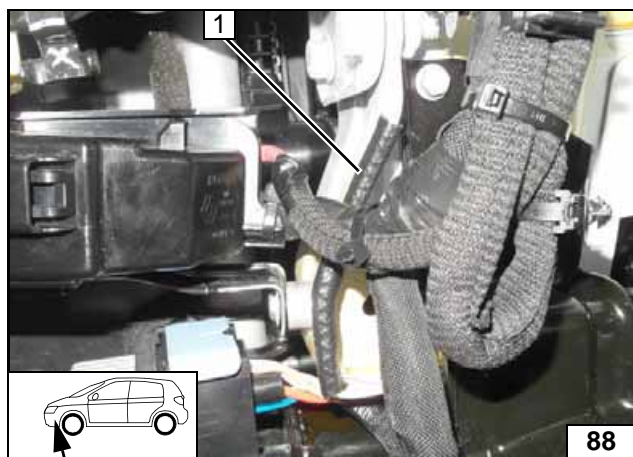

1 150mm edge protection

Installing  
edge protec-  
tion

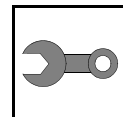

## Final Work



Reassemble the components in reverse order. Check all hoses, clamps and all electrical connections for firm seating. Insulate loose wire ends and tie back.  
Only use manufacturer-approved coolant. Spray the heater components with anti-corrosion wax (Tectyl 100K).

- Connect the battery.
- Fill and bleed the coolant circuit according to the vehicle manufacturer's instructions.
- Program MultiControl CAR, teach Telearstart transmitter.
- Make A/C control panel settings according to the 'operating instructions' (see the installation documentation of the relevant A/C control)
- Place the 'Switch off parking heater before refuelling' caution label near the filler neck.
- For initial startup and function check, please see installation instructions.

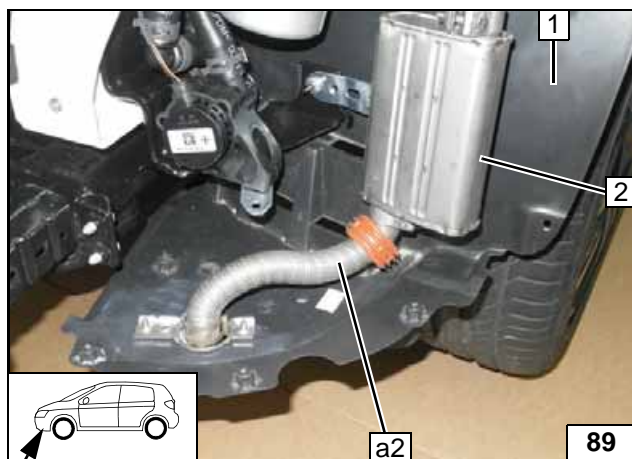

Ensure sufficient distance between wheel well trim **1** and exhaust silencer **2** as well as exhaust pipe **a2** (at least 20mm); correct if necessary.



Checking distance

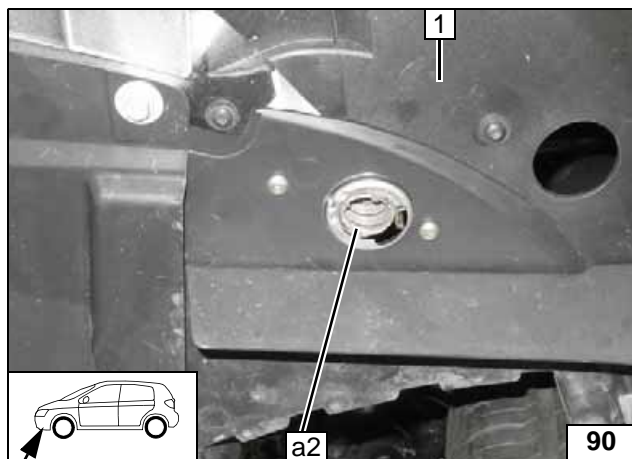

Install bumper **1**. Ensure that exhaust pipe **a2** is fitted correctly in exhaust end fastener.



Checking exhaust pipe a2

Webasto Thermo & Comfort SE  
Postfach 1410  
82199 Gilching  
Germany  
Internet: [www.webasto.com](http://www.webasto.com)  
Technical Extranet:  
<http://dealers.webasto.com>





### Template for Fuel Standpipe

Top view

