



Water Heater

Thermo Top Evo Parking Heater
"Island based circuit"



With FuelFix

Installation Documentation Kia cee`d

Validity

Manufacturer	Model	Type	EG-BE-No. / ABE
Kia	cee`d	JD	e4 * 2007 / 46 * 0496

Motorisation	Fuel	Transmission type	Output in kW	Displacement in cm ³	Engine code
1.0 GDI	Petrol	6-speed SG	88	998	G3LC

SG = manual transmission

From model year 2015
Left-hand drive vehicle

Verified equipment variants: Automatic air-conditioning
Front fog lights
LED daytime running lights
Halogen front fog lights

Not verified: Manual air-conditioning
Cornering light

Total installation time: approx. 8.5 hours

Table of Contents

Validity	1	Preparing Installation Location	12
Necessary Components	2	Preparing Heater	13
Installation Overview	2	Installing Heater	15
Information on Total Installation Time	2	Coolant Circuit	16
Information on Operating and Installation Instructions	3	Fuel	21
Information on Validity	4	Installing FuelFix	23
Technical Information	4	Combustion Air	27
Explanatory Notes on Document	4	Installing exhaust end fastener	30
Preliminary Work	5	Final Work	32
Heater Installation Location	5	FuelFix Template	34
Preparing Electrical System	6	Operating Instructions for Automatic Air-Conditioning	35
Electrical System	7		
Fan Controller for Automatic Air-Conditioning	8		
MultiControl CAR Option	10		
Remote Option (Telestart)	10		
ThermoCall Option	11		

Necessary Components

- Basic delivery scope of Thermo Top Evo in accordance with price list
- Installation kit with FuelFix Kia cee`d 2015 Petrol: **1324577A**
- Heater control in accordance with price list and upon consultation with end customer
- In case of MultiControl CAR installation: Digital timer wire extension: **1319724_**
- In case of Telestart, indicator lamp in accordance with price list and in consultation with end customer

Installation instructions:

- Arrange for the vehicle to be delivered with the tank only about ¼ full.
- The installation location of the push button in case of Telestart or Thermo Call should be confirmed with the end customer.
- Depending on the space required and the vehicle manufacturer's instructions, we recommend the use of a vehicle battery with a higher electrical capacity.
- Integration in the coolant circuit is based on the island circuit model. In parking heating mode there will be **no** engine pre-heating.

Installation Overview

Legend:

1. Heater
2. Engine compartment fuse holder
3. Passenger compartment relay and fuse holder
4. Circulating pump
5. MultiControl CAR
6. Metering pump
7. FuelFix

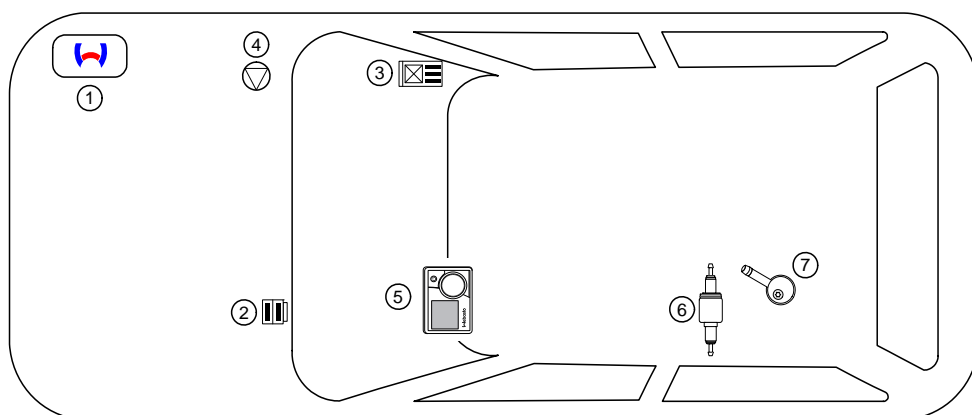

Information on Total Installation Time

The total installation time includes the time needed for mounting and demounting the vehicle-specific components, the heater specific installation time and all other times required for the system integration and initial start-up of the heater. The total installation time may vary for vehicle equipment other than provided.

Information on Operating and Installation Instructions

1 Important information (not complete)

1.1 Installation and repair



The improper installation or repair of Webasto heating and cooling systems can cause fire or the leakage of deadly carbon monoxide, leading to serious injury or death.



To install and repair Webasto heating and cooling systems you need to have completed a special company training course and have the appropriate technical documentation, special tools and special equipment.



Installation and repair may **ONLY** be carried out by persons trained and certified in a Webasto training course. **NEVER** try to install or repair Webasto heating or cooling systems if you have not completed a Webasto training course, you do not have the necessary technical skills and you do not have the technical documentation, tools and equipment available to ensure that you can complete the installation and repair work properly.

Only use genuine Webasto parts. See the Webasto air and water heaters accessories catalogue for this purpose.

1.2 Operation

To ensure safe operation, we recommend having the heater checked every two years by an authorised Webasto dealer, especially when used over a long period and/or under extreme environmental conditions.

Do not operate the heater in closed rooms due to the danger of poisoning and suffocation.

Always switch off the heater before refuelling.

The heater may only be used with the prescribed fuel diesel (DIN EN 590) or petrol (DIN EN 228).

The heater may not be cleaned with a high-pressure cleaner.

1.3 Please note

ALWAYS follow all Webasto installation and operating instructions and observe all warnings.

To become familiar with and understand all functions and properties of the heater, the operating instructions must be read carefully and observed at all times.

For proper, safe installation and repair work, the installation instructions with all warnings and safety information must be carefully read and observed at all times. Please always contact a workshop authorised by Webasto for all installation and repair work.

Important

Webasto shall assume no liability for defects, damage and injuries resulting from a failure to observe the installation, repair and operating instructions of the information contained in them.

This liability exclusion particularly applies to improper installations and repairs, installations and repairs by untrained persons or in the case of a failure to use genuine spare parts.

The liability due to culpable disregard to life, limb or health and due to damage or injuries caused by a wilful or reckless breach of duty remain unaffected, as does the obligatory product liability.

Installation should be carried out according to the general, standard rules of technology. Unless specified otherwise, fasten hoses, lines and wiring harnesses to original vehicle lines and wiring harnesses using cable ties. Insulate loose wire ends and tie back. Connectors on electronic components have to audibly click into place during installation.

Sharp edges should be fitted with rub protection. Spray unfinished body areas, e.g. drilled holes, with anti-corrosion wax (Tectyl 100K).

Observe the instructions and guidelines of the respective vehicle manufacturer for demounting and mounting vehicle specific components!

The initial startup is to be executed with the Webasto Thermo Test Diagnosis.

When installing a programmable control module (e.g. a PWM Gateway), the corresponding settings must be checked or adjusted.

2 Statutory regulations governing installation

Guidelines	Thermo Top Evo
Heating Directive ECE R122	E1 00 0258
EMC Directive ECE R10	E1 04 5627

Note

The regulations of these guidelines are binding in the scope of the Directive 70/156/EEC and/or 2007/46/EC (for new vehicle models from 29/04/2009) and should also be observed in countries in which there are no special regulations.

Important

Failure to follow the installation instructions will result in the invalidation of the type approval for the heater and therefore invalidation of the general **homologation of the vehicle**.

Note

The heater is licensed in accordance with paragraph 19, section 3, No. 2b of the StVZO (German Road Traffic Licensing Authority).

2.1 Excerpt from ECE regulation 122 (heating system) paragraph 5 for the installation of the heater

Beginning of excerpt.

ANNEX VII

REQUIREMENTS FOR COMBUSTION HEATERS AND THEIR INSTALLATION

1. GENERAL REQUIREMENTS

1.7.1. A clearly visible tell-tale in the operator's field of view shall inform when the combustion heater is switched on or off.

2. VEHICLE INSTALLATION REQUIREMENTS

2.1. Scope

2.1.1. Subject to paragraph 2.1.2, combustion heaters shall be installed according to the requirements of this Annex.

2.1.2. Vehicles of category O having liquid fuel heaters are deemed to comply with the requirements of this Annex.

2.2. Positioning of heater

2.2.1. Body sections and any other components in the vicinity of the heater must be protected from excessive heat and the possibility of fuel or oil contamination.

2.2.2. The combustion heater shall not constitute a risk of fire, even in the case of overheating. This requirement shall be deemed to be fulfilled if the installation ensures an adequate distance to all parts and suitable ventilation, by the use of fire resistant materials or by the use of heat shields.

2.2.3. In the case of M2 and M3 vehicles, the heater must not be positioned in the passenger compartment. However, an installation in an effectively sealed envelope which also complies with the conditions in paragraph 2.2.2 may be used.

2.2.4. The label referred to in paragraph 1.4 or a duplicate, must be positioned so that it can be easily read when the heater is installed in the vehicle.

2.2.5. Every reasonable precaution should be taken in positioning the heater to minimise the risk of injury and damage to personal property.

2.3. Fuel supply

2.3.1. The fuel filler must not be situated in the passenger compartment and must be provided with an effective cap to prevent fuel spillage.

2.3.2. In the case of liquid fuel heaters, where a supply separate to that of the vehicle is provided, the type of fuel and its filler point must be clearly labelled.

2.3.3. A notice, indicating that the heater must be shut down before refuelling, must be affixed to the fuelling point. In addition a suitable instruction must be included in the manufacturer's operating manual.

2.4. Exhaust system

2.4.1. The exhaust outlet must be located so as to prevent emissions from entering the vehicle through ventilators, heated air inlets or opening windows.

2.5. Combustion air inlet

2.5.1. The air for the combustion chamber of the heater must not be drawn from the passenger compartment of the vehicle.

2.5.2. The air inlet must be so positioned or guarded that blocking by rubbish or luggage is unlikely.

2.6. Heating air inlet

2.6.1. The heating air supply may be fresh or recirculated air and must be drawn from a clean area not likely to be contaminated by exhaust fumes emitted either by the propulsion engine, the combustion heater or any other vehicle source.

2.6.2. The inlet duct must be protected by mesh or other suitable means.

2.7. Heating air outlet

2.7.1. Any ducting used to route the hot air through the vehicle must be so positioned or protected that no injury or damage could be caused if it were to be touched.

2.7.2. The air outlet must be so positioned or guarded that blocking by rubbish or luggage is unlikely.

End of excerpt.

In multilingual versions the German language is binding.

Information on Validity

This installation documentation applies to Kia cee`d Petrol vehicles - for validity, see page 1 - from model year 2015 and later, assuming technical modifications to the vehicle do not affect installation, any liability claims excluded. Depending on the vehicle version and equipment, modifications may be necessary during installation with respect to this 'installation documentation'.

Vehicle and engine types, equipment variants and other specifications not listed in this installation documentation have not been tested. However, installation according to this installation documentation may be possible.

Technical Information

Special Tools

- Hose clamp pliers for auto-tightening hose clamps
- Hose clamp pliers for Clic hose clamps of type W
- Automatic wire stripper 0.2 - 6mm²
- Crimping pliers for cable lug / tab connector 0.5 - 6mm²
- Torque wrench for 2.0 - 10 Nm
- Hose clamping pliers
- Metric thread-setter kit
- Deep-hole marker
- Webasto Thermo Test Diagnosis with current software

Dimensions

- All dimensions are in mm.

Tightening torque values

- Tightening torque values of 5x13 heater bolts and 5x11 heater stud bolts = 8Nm.
- Tightening torque value of 5x15 water connection piece retaining plate bolt = 7Nm.
- Tighten other bolt connections in accordance with manufacturer's instructions or in accordance with state-of-the-art technology.

Explanatory Notes on Document

You will find an identification mark on the outside top right corner of the page in question to provide you with a quick overview of the individual working steps.

Special features are highlighted using the following symbols:

Mechanical System



Electrical System



Coolant Circuit



Combustion Air

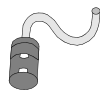

Fuel



Exhaust Gas



Software



Specific risk of damage to components.



Specific risk due to electrical voltage.



Specific risk of injury or fatal accidents.



Specific risk of fire or explosion.



Reference to the manufacturer's vehicle-specific documents or to the general installation instructions of Webasto components.



Reference to a special technical feature.



The arrow in the vehicle icon indicates the position on the vehicle and the viewing angle.



Tightening torque according to the manufacturer's vehicle-specific documents.



Preliminary Work

Vehicle



- Open the fuel tank cap.
- Ventilate the fuel tank.
- Close the fuel tank cap again.
- Depressurise the cooling system.
- Disconnect and remove the battery.
- Remove the air filter box.
- Remove the engine control unit.
- Remove the left underide protection.
- Remove the bumper trim.
- Remove the right wheel-well inner panel.
- Remove the lateral engine compartment trim on the right.
- Remove the lateral instrument panel trim on the right.
- Remove the glove box.
- Remove the glove box frame.
- Remove the lower instrument panel trim on the right and on the left.
- Remove the instrument panel trim on the left.
- Remove the A/C control panel (only with automatic air-conditioning).
- Fold up the rear bench seat.
- Open the tank-fitting service lid.

Heater

- Remove years that do not apply from the type and duplicate label.
- Attach the duplicate label (type label) visibly in the appropriate place in the engine compartment.

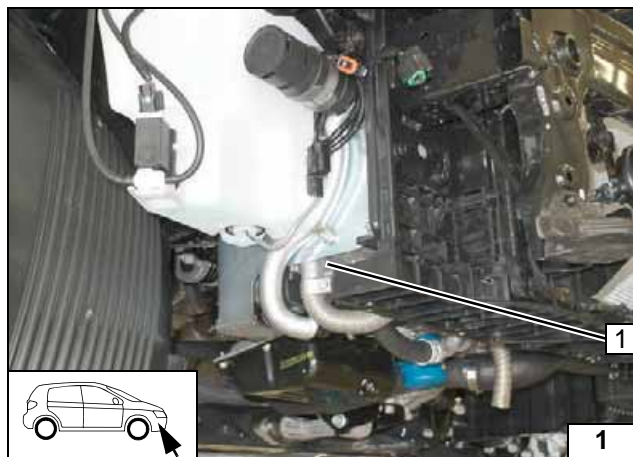

Heater Installation Location

- 1 Heater

Installation location

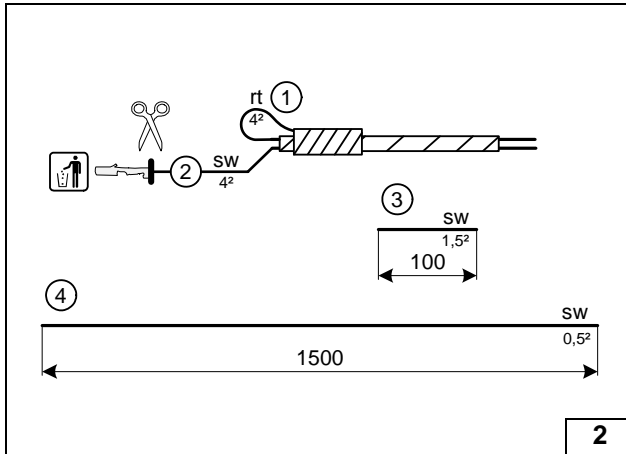
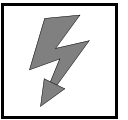

Preparing Electrical System

Wire sections retain their numbering throughout the entire document.

Produce all following electrical connections as shown in the wiring diagram.

Pull wire ④ into provided protective sleeving.

- ① Insulate red (rt) wire of fan wiring harness and tie back.
- ② Black (sw) wire of fan wiring harness



Cutting to length / assigning wires

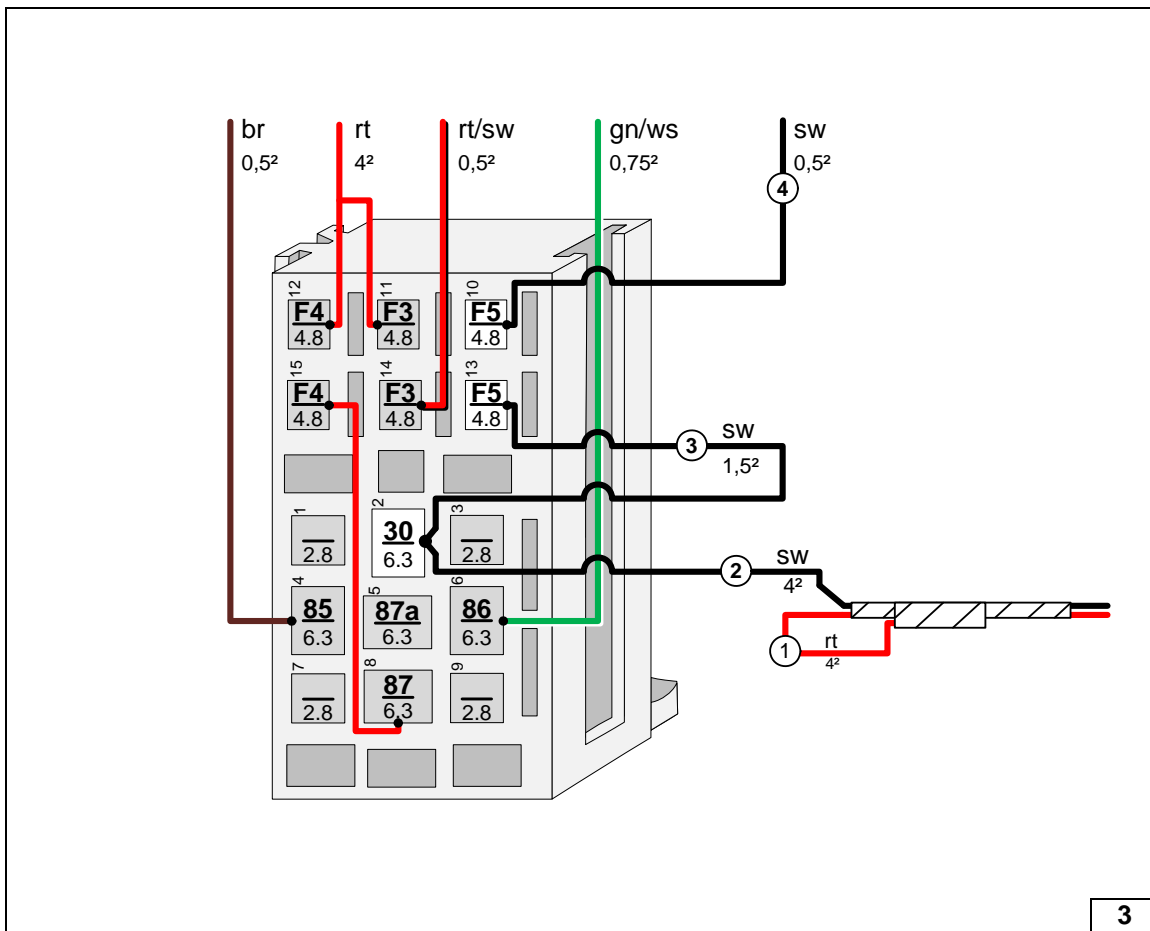

Connecting wires to passenger compartment relay and fuse holder

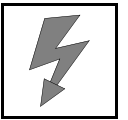

Electrical System



Wiring harness pass through

- 1 Protective rubber plug
- 2 Wiring harnesses of heater and heater control

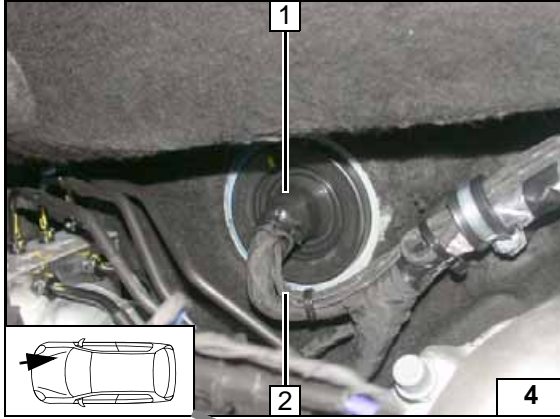

Passenger compartment relay and fuse holder

- 1 M5x16 bolt, large diameter washer [2x], retaining plate for fuse holder, nut
- 2 Angle bracket
- 3 Original vehicle bolt, flanged nut
- 4 Fuses F3-5

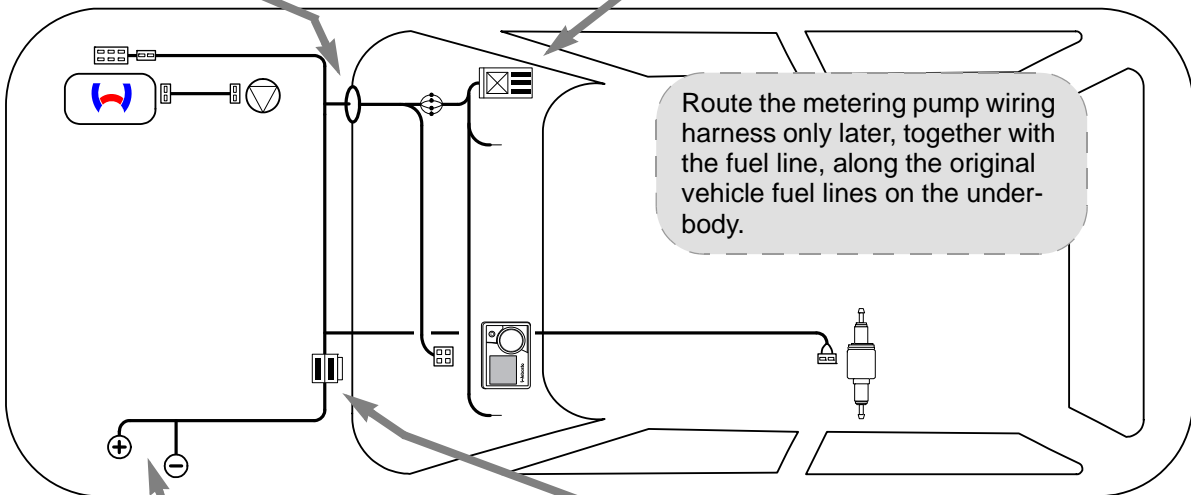
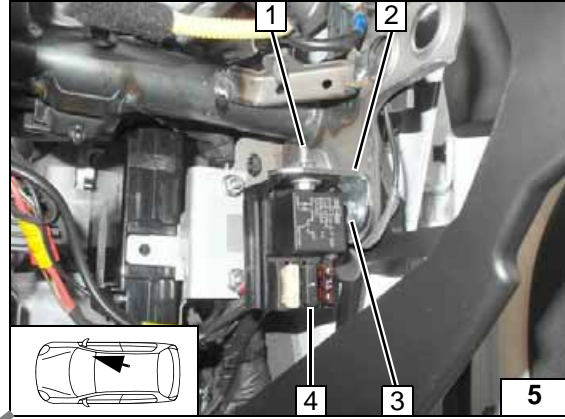

Wiring harness routing diagram

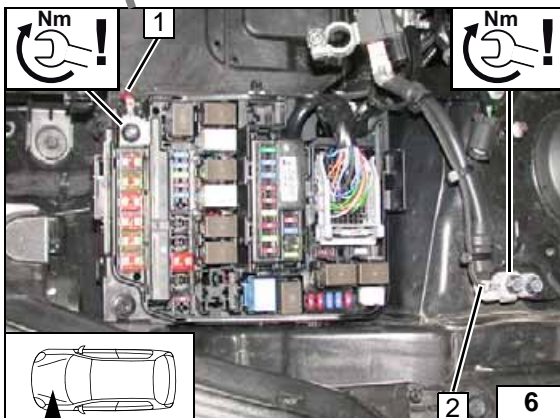

Positive and earth wire

- 1 Positive wire on original vehicle positive distributor
- 2 Earth wire on original vehicle earth support point

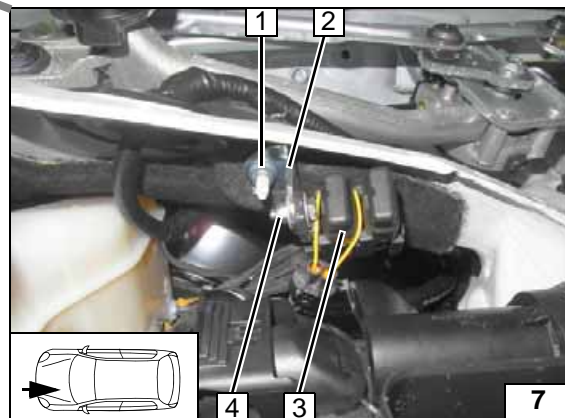

Engine compartment fuse holder

- Remove plastic nut at position 1.
- 1 M6 flanged nut, original vehicle stud bolt
 - 2 Angle bracket
 - 3 M5x16 bolt, washer [2x], retaining plate for fuse holder, nut
 - 4 Fuses F1-2





Fan Controller for Automatic Air-Conditioning

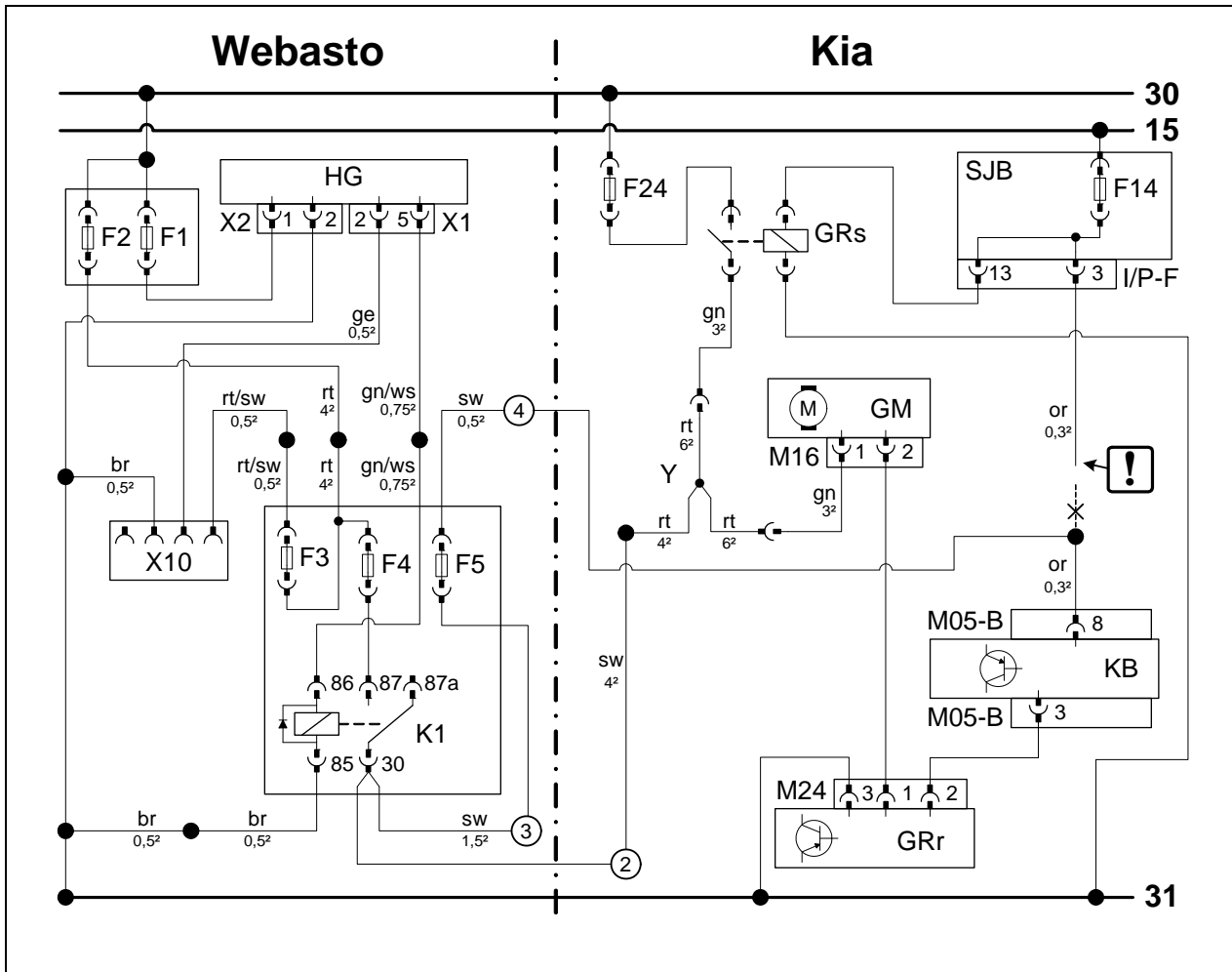

Wiring diagram

Webasto components		Vehicle components		Colours and symbols	
X1	6-pin heater connector	SJB	Smart Junction Box	rt	red
X2	2-pin heater connector	I/P-F	32-pin connector SJB	sw	black
F1	20A fuse	F14	7.5A fuse	br	brown
F2	30A fuse	GRs	Fan relay	gn	green
X10	4-pin connector of heater control	F24	40A fuse	or	orange
F3	1A fuse	GM	Fan motor	ws	white
F4	25A fuse	M16	2-pin connector of GM	gn/ws	green/white
F5	7.5A fuse	KB	A/C control panel	rt/sw	red/black
K1	Fan relay	M05	Connector of KB		
Y	Power adapter	KB	A/C control panel		
		M05-B	Connector for A/C control panel		
		GRr	Fan controller		
		M24	4-pin connector of GRr		
					Insulate wire end and tie back
				X	Cutting point
					Wiring colours may vary.

Legend

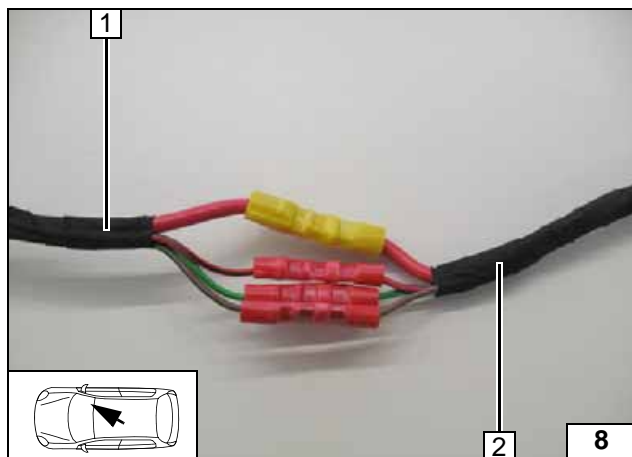
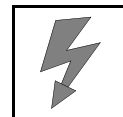

- 1 Wiring harness of passenger compartment relay and fuse holder
- 2 Wiring harness of heater

Connecting same colour wires of wiring harnesses

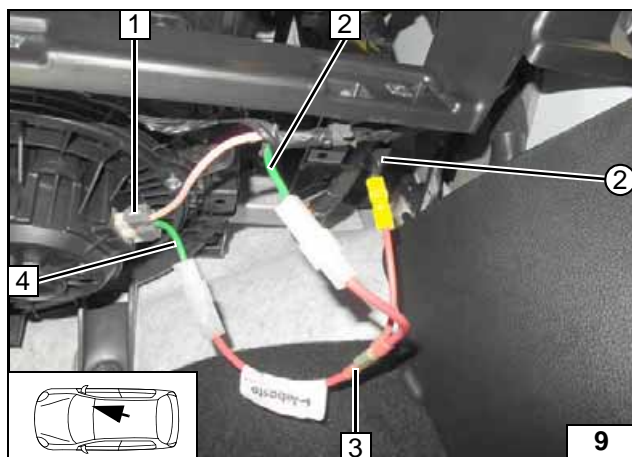

Connection to 2-pin M16 connector 1 from fan motor.



- 2 Green (gn) wire from GRs
- 3 Y power adapter
- 4 Green (gn) wire of 2-pin connector M16
- ② Black (sw) wire of K1/30, fan wiring harness

Connecting fan motor

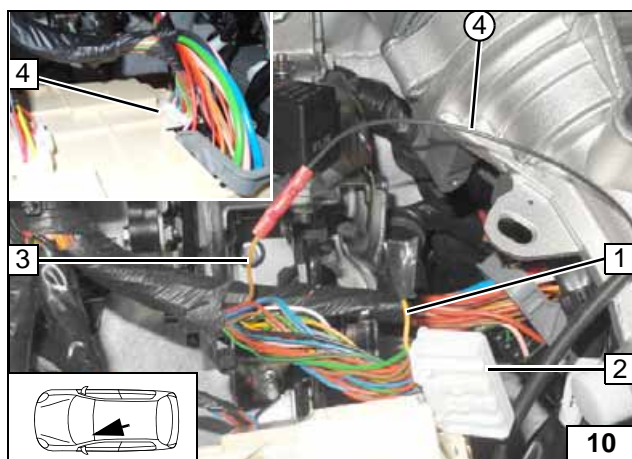

Connection to 32-pin connector I/P-F 2 of Smart Junction Box.



- 1 Insulate and tie back orange (or) wire of connector I/P-F, pin 3
- 3 Orange (or) wire from connector M05-B, pin 8
- 4 Position of connector I/P-F
- ④ Black (sw) wire of fuse F5

Connecting A/C control panel

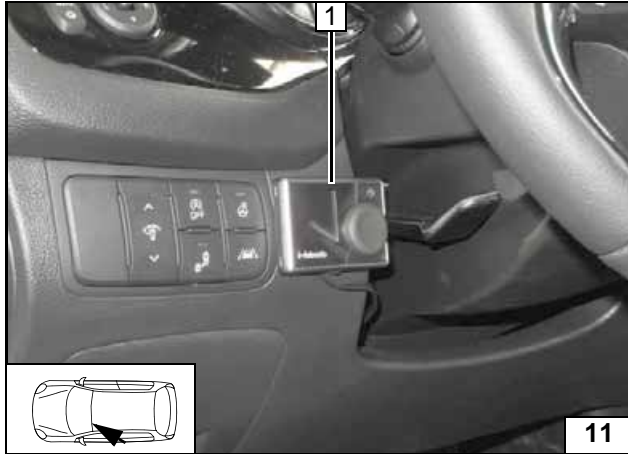
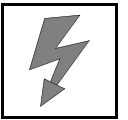

MultiControl CAR Option

1 MultiControl CAR



Installing MultiControl CAR

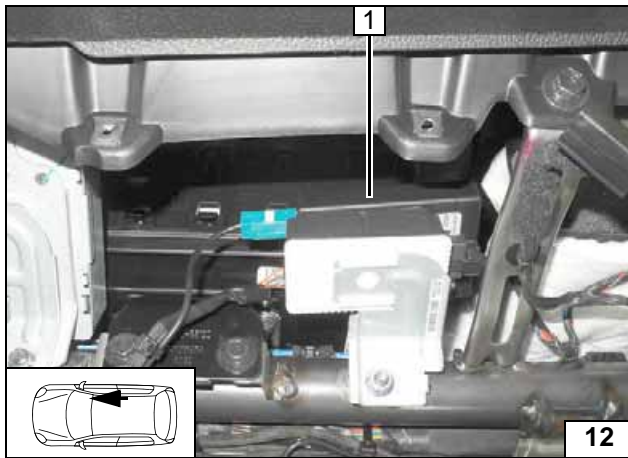

Remote Option (Telestart)

Fasten receiver 1 with double-sided adhesive tape.



Installing receiver

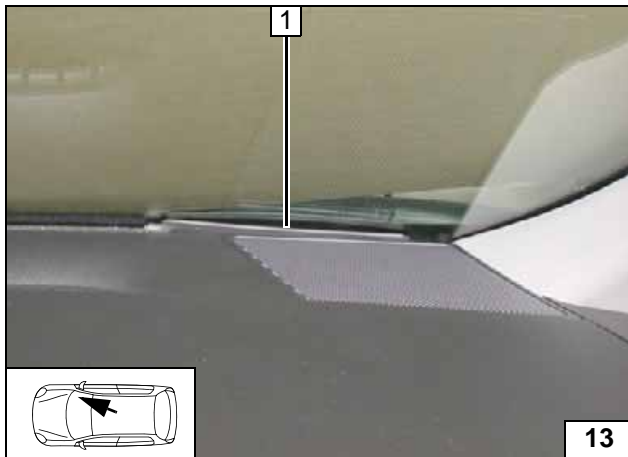

1 Aerial

Installing aerial

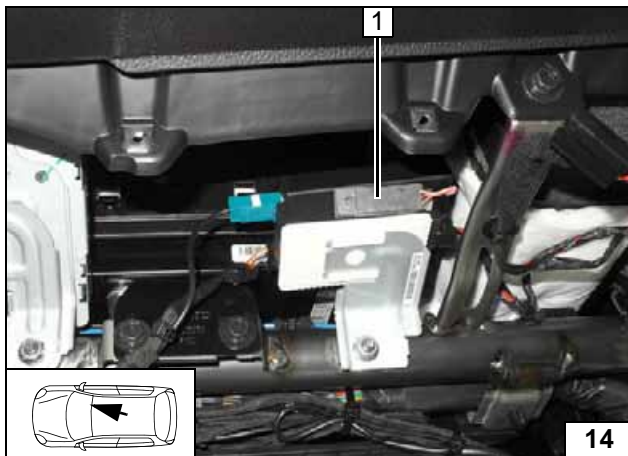

Temperature sensor T100 HTM

Fasten temperature sensor 1 using double-sided adhesive tape.



Installing temperature sensor

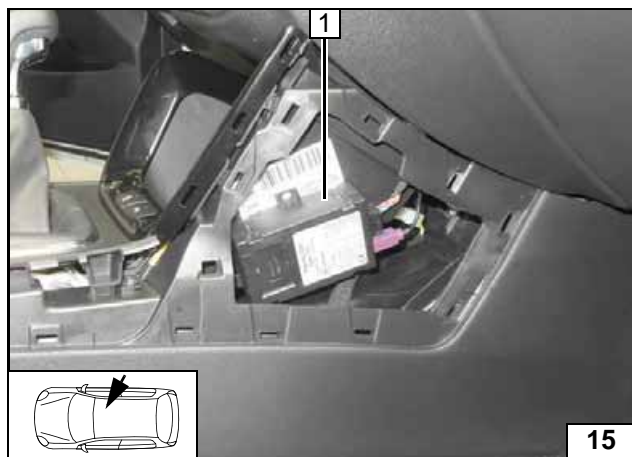
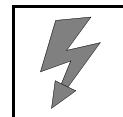

ThermoCall Option

Fasten receiver 1 with double-sided adhesive tape.



Installing receiver

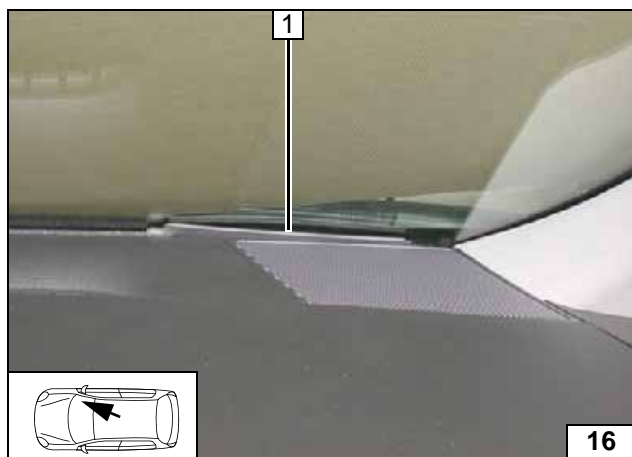

1 Aerial (optional)

Installing aerial

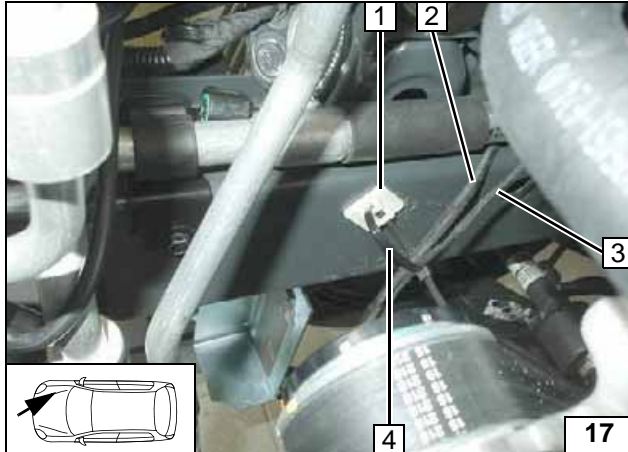
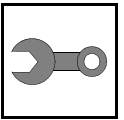

Preparing Installation Location



Install cable tie 4 loosely, will be tightened later.

- 1 Self-adhesive socket
- 2 Wiring harness of heater
- 3 Metering pump wiring harness

Routing wiring harness

- 1 Rivet nut, existing hole

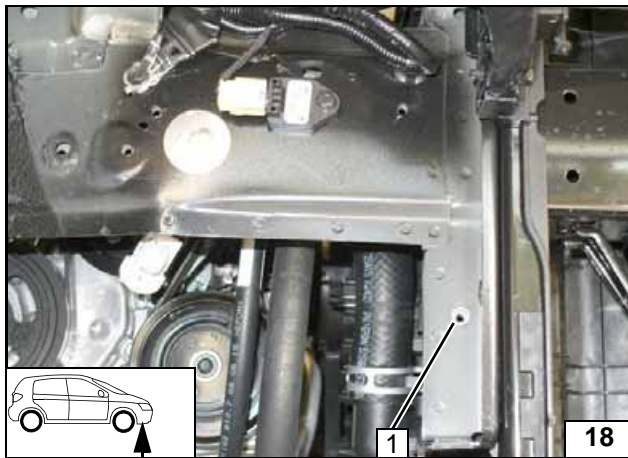

Installing rivet nut

Align bracket 1.



- 2 Copy hole pattern [3x]
- 3 M6x20 bolt

Copying hole pattern

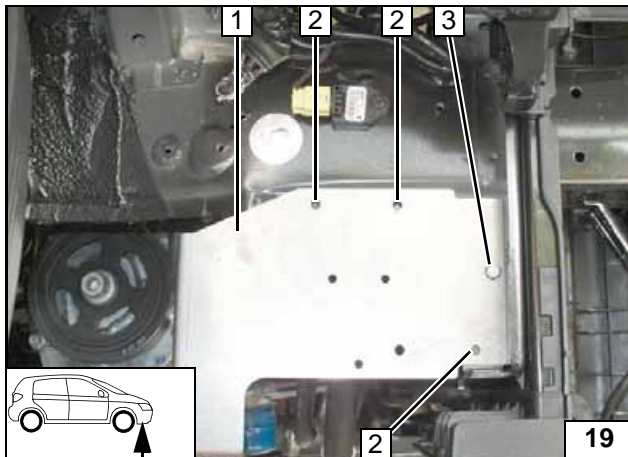

- 1 8mm dia. hole [3x]

Drilling hole

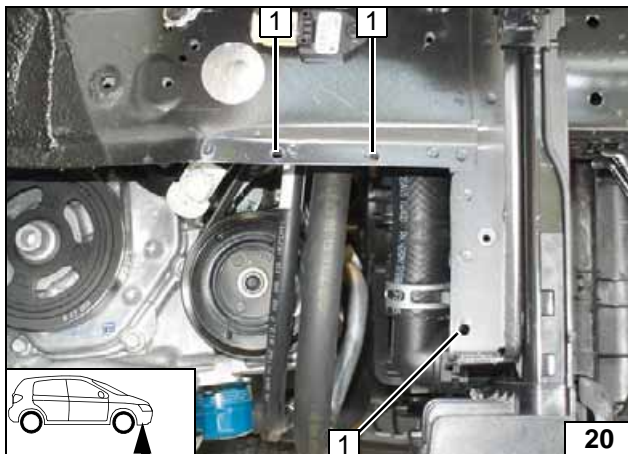

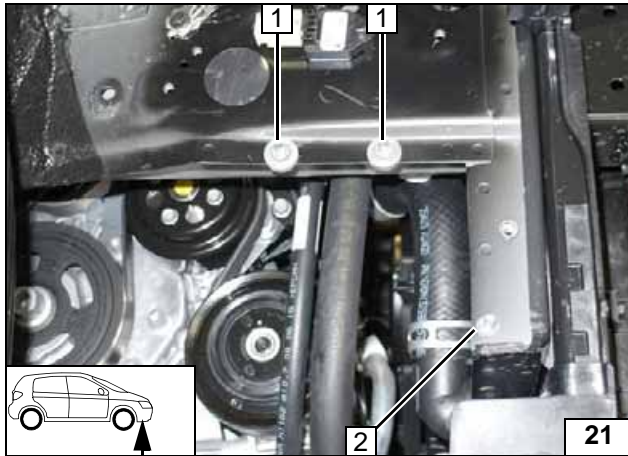
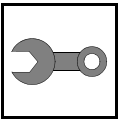

- 1 M6x20 bolt, 5mm spacer, pin lock
- 2 M6x20 bolt, pin lock

Preparing bracket assembly

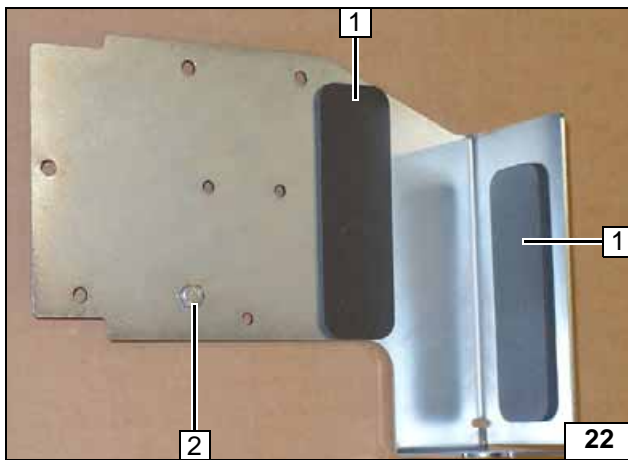

- 1 Self-adhesive foam [2x]
- 2 M6x16 bolt, pin lock

Preparing bracket

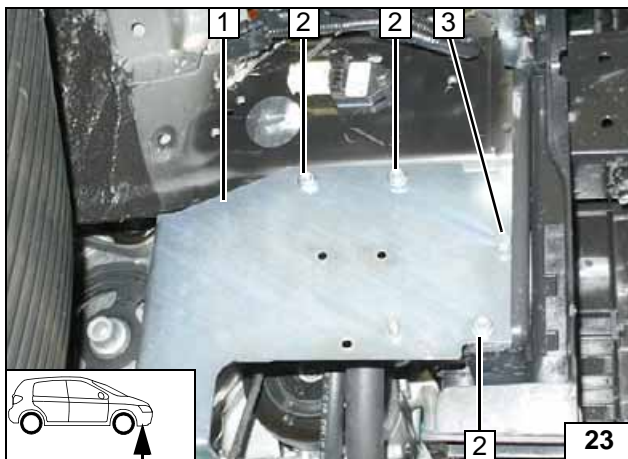

Install bracket 1 loosely.

- 2 Flanged nut [3x]
- 3 M6x20 bolt, spring lockwasher



Installing bracket

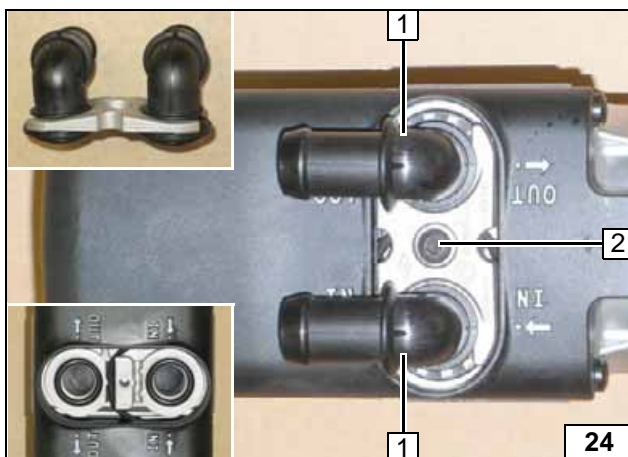

Preparing Heater

- 1 Water connection piece, sealing ring [2x each]
- 2 5x15 self-tapping bolt, retaining plate of water connection piece



Installing water connection piece

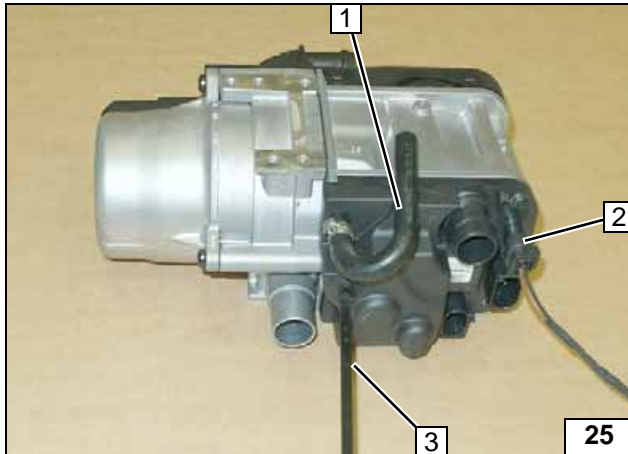
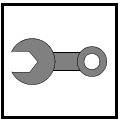

- 1 180° moulded hose, 10mm dia. clamp
- 2 Connector of circulating pump wiring harness
- 3 Cable tie for 6mm dia. hole

Installing circulating pump wiring harness

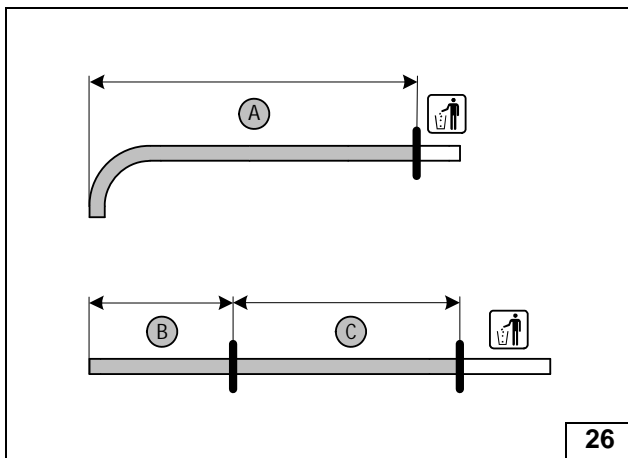

A = 90°, 18mm dia. moulded hose

- A = 390
- B = 650
- C = 1050

Cutting hoses to length

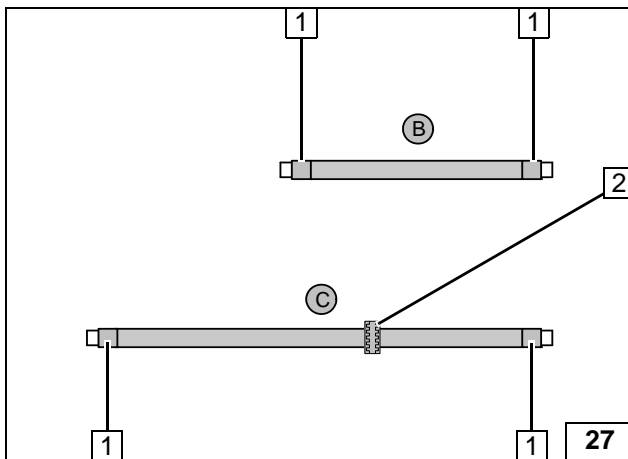

Push braided protection hoses onto hoses **B** and **C** and cut to length. Cut heat shrink plastic tubing to size.

- 1 50 mm long heat shrink plastic tubing [4x]
- 2 Black (sw) rubber isolator



Preparing hoses

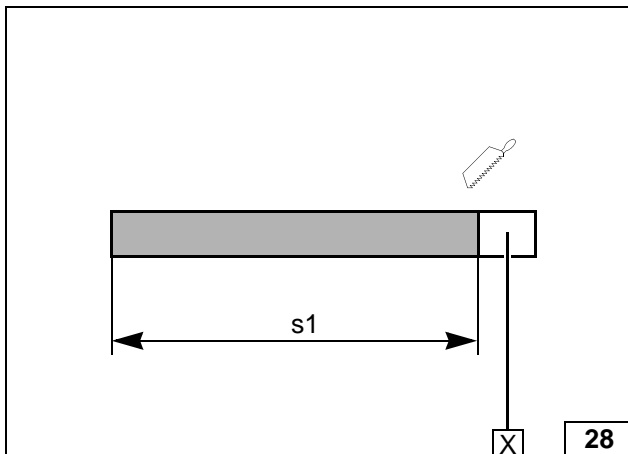

s1 = 460

X =

Cutting combustion air pipe to length

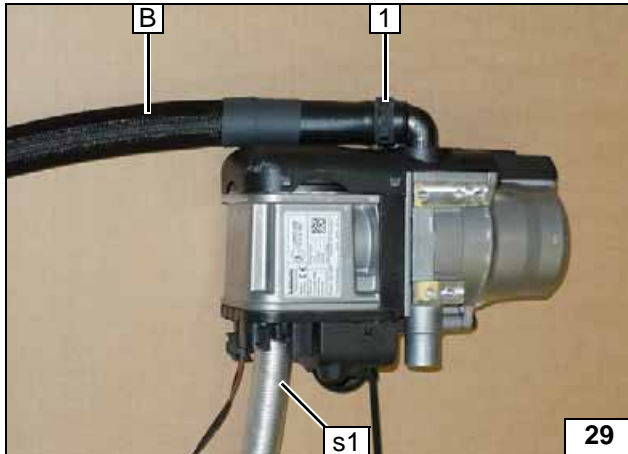
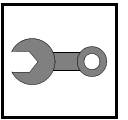

- 1 25mm dia. spring clip



Premounting hose B and combustion air pipe s1

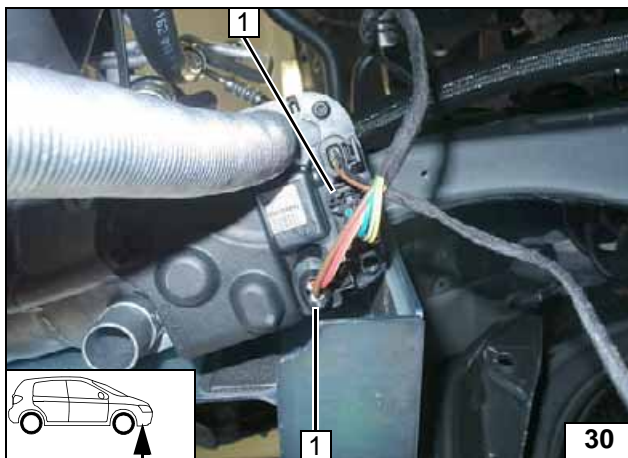

Installing Heater

- 1 Heater wiring harness connector [2x]

Installing wiring harness

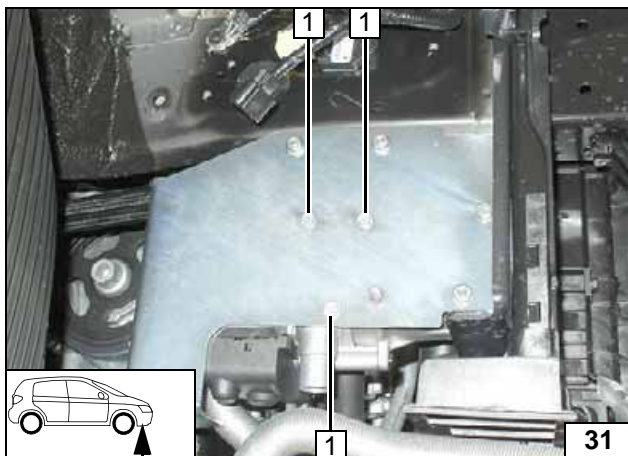

Tighten all screw connections!

- 1 5x13 self-tapping bolt [3x]



Installing heater

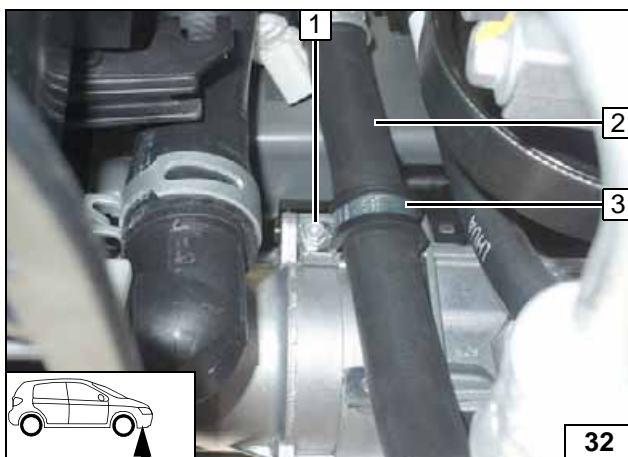

- 1 5x13 self-tapping bolt
- 2 Original vehicle A/C line
- 3 25 mm dia. rubber-coated p-clamp

Securing A/C line

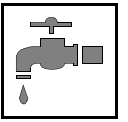

Coolant Circuit





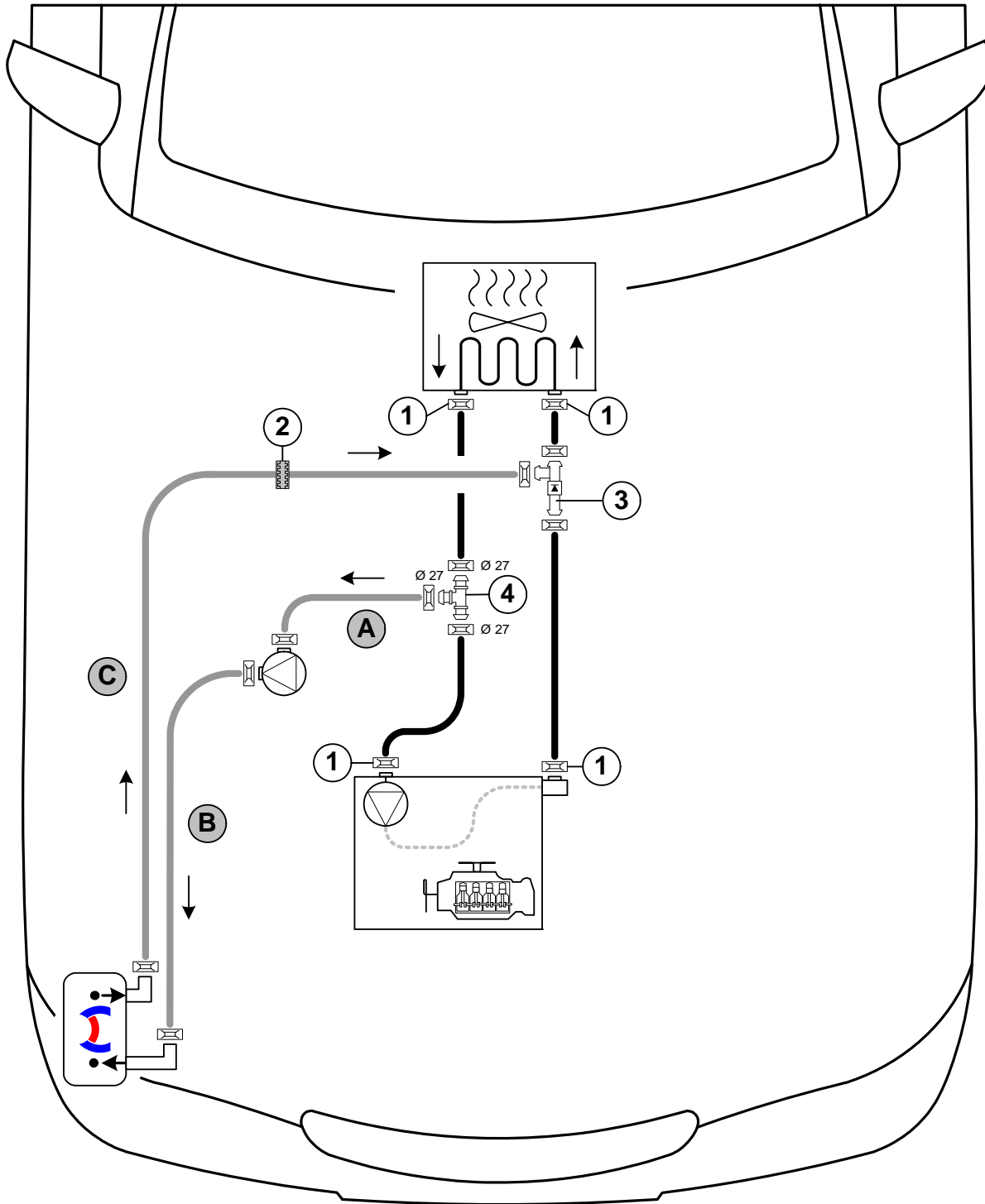

Any coolant running off should be collected in an appropriate container. Route hoses kink-free. Unless specified otherwise, always fasten using cable ties. Position clamps so that other hoses cannot be damaged. The heater must be filled with coolant when installing the hoses.

The connection should be modelled on an 'island' circuit and based on the following diagram:



Hose routing diagram

All spring clips without a specific designation  = 25 mm dia. 1 = Original vehicle spring clip .
 2 = Black (sw) rubber isolator . 3 = check valve . 4 = T-piece .



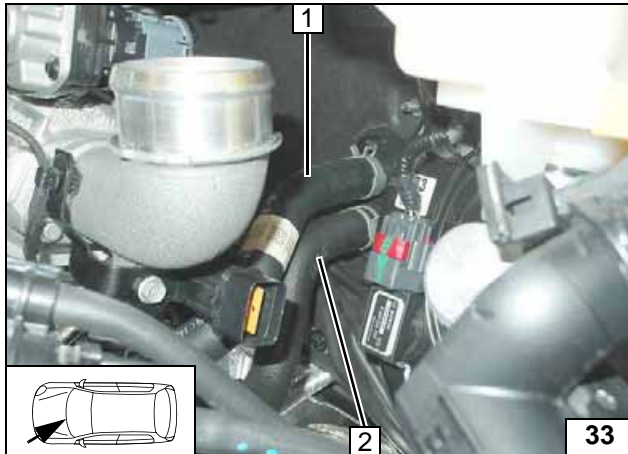

Remove hose of heat exchanger outlet/engine inlet **1** and hose of engine outlet/heat exchanger inlet **2**. Spring clips will be reused!



Removing hose

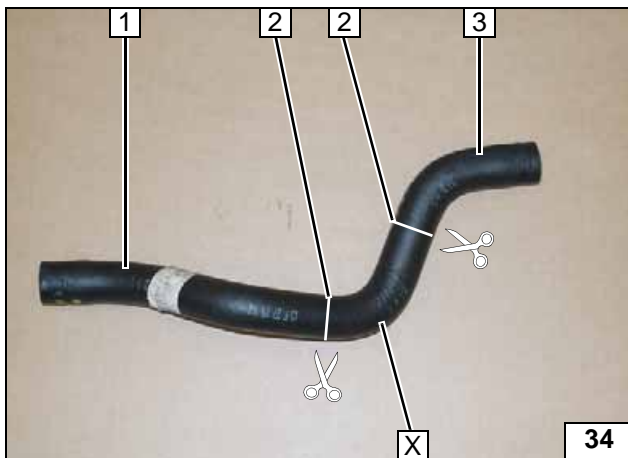

Cut hose of engine outlet / heat exchanger inlet at marking **2** [2x].

- 1** Engine outlet hose section
- 3** Hose section of heat exchanger inlet

X =



Cutting hose of engine outlet / heat exchanger inlet



- 1** Engine outlet hose section
- 2** 18x18x18 check valve
- 3** Hose section of heat exchanger inlet
- 4** Original vehicle spring clip [2x]



Premounting check valve

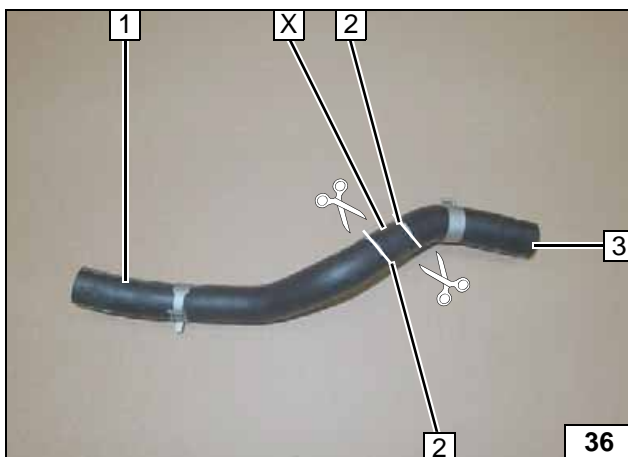

Cut hose of heat exchanger outlet / engine inlet at marking **2** [2x].

- 1** Engine inlet hose section
- 3** Hose section of heat exchanger outlet

X =



Cutting hose of heat exchanger outlet / engine inlet

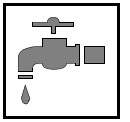

- 1 Engine inlet hose section
- 2 20x20x20 T-piece
- 3 Original vehicle spring clip [2x]
- 4 Hose section of heat exchanger outlet



Premounting T-piece

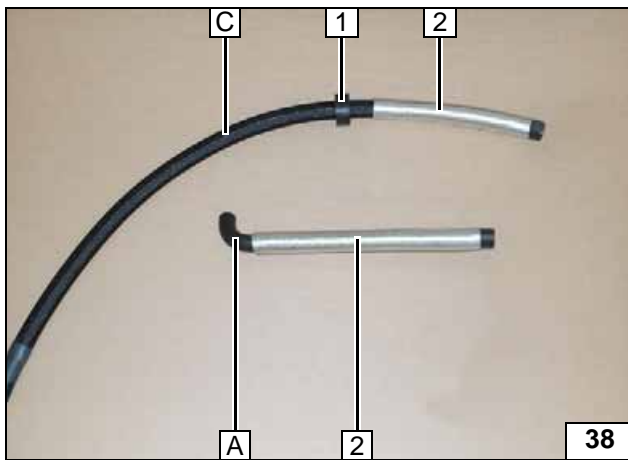

Cut provided 600mm long heat protection tube in half.

- 1 Black (sw) rubber isolator
- 2 300mm long heat protection tube [2x]



Premounting hoses

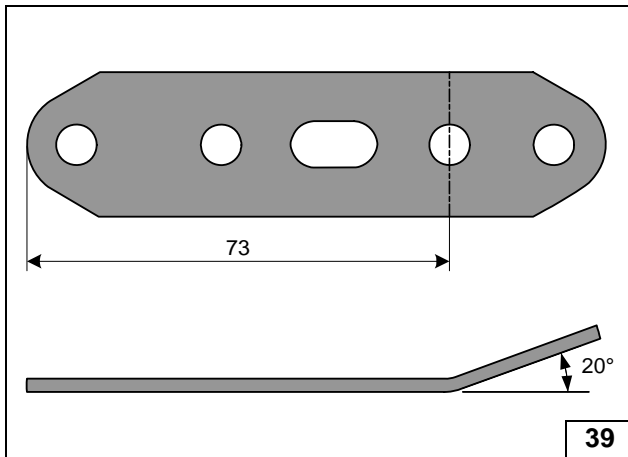

Angling down perforated bracket

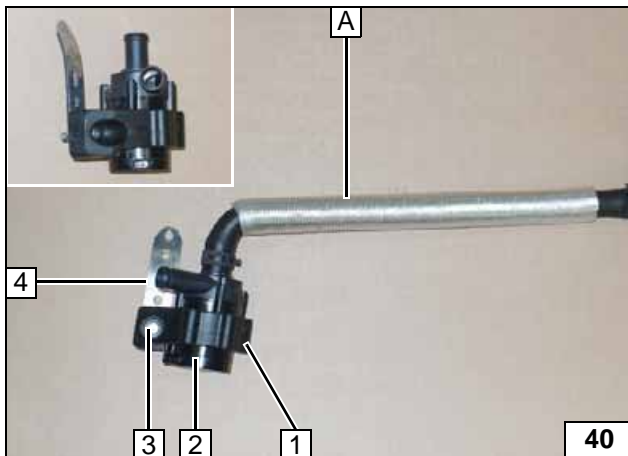

- 1 Circulating pump mount
- 2 Circulating pump
- 3 M6x25 bolt, flanged nut
- 4 Perforated bracket

Premounting circulating pump

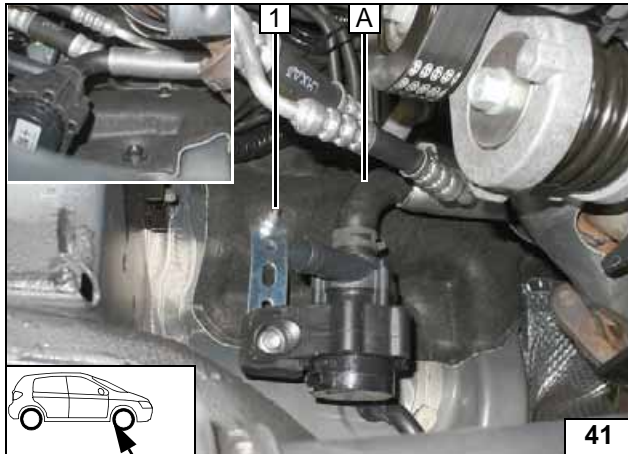
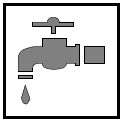

- 1 Original vehicle stud bolt, flanged nut

Installing circulating pump

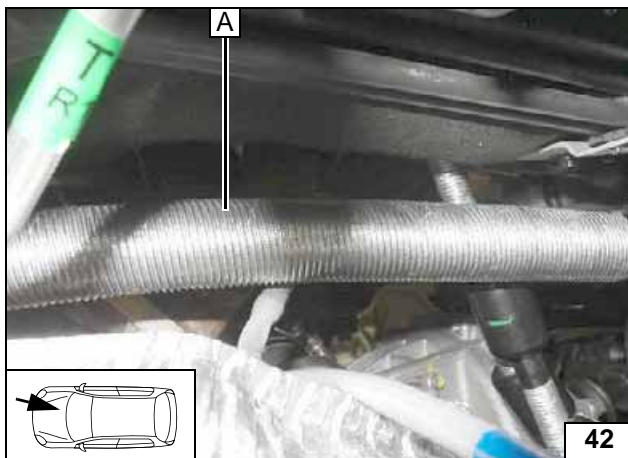

Routing of hose A

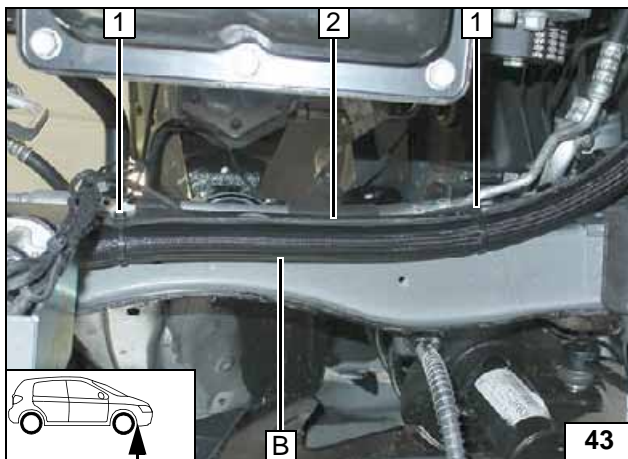

- 1 Cable tie [2x]
- 2 Wiring harness of circulating pump

Routing of hose B in engine compartment

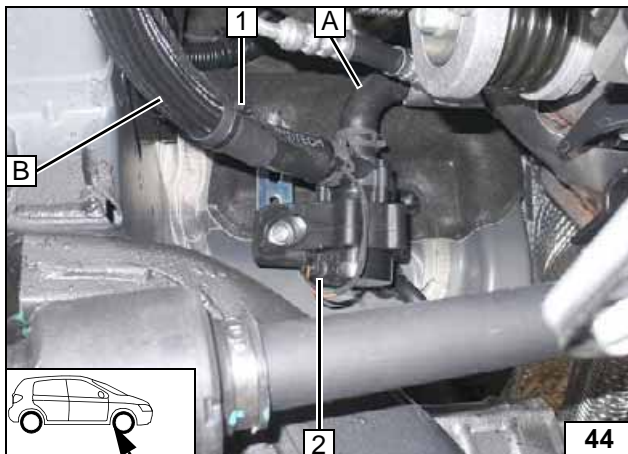

- 1 Cable tie [2x]
- 2 Connector of circulating pump wiring harness

Connecting circulating pump

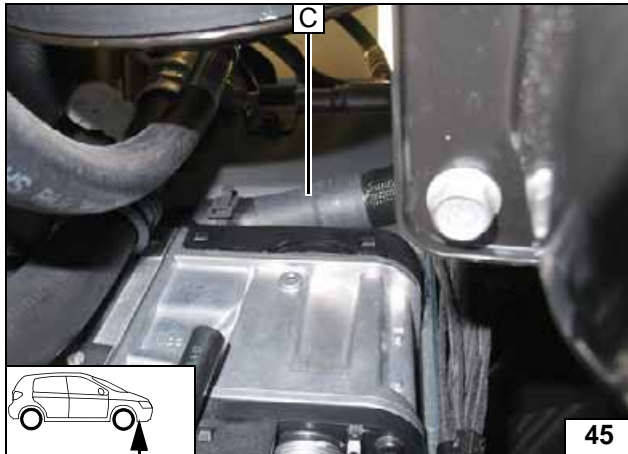
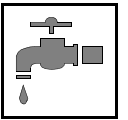

**Connect-
ing hose C
to heater**

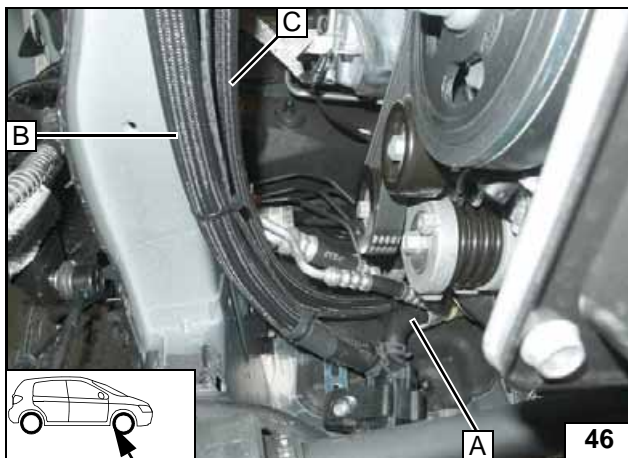

**Routing in
engine
compartment**

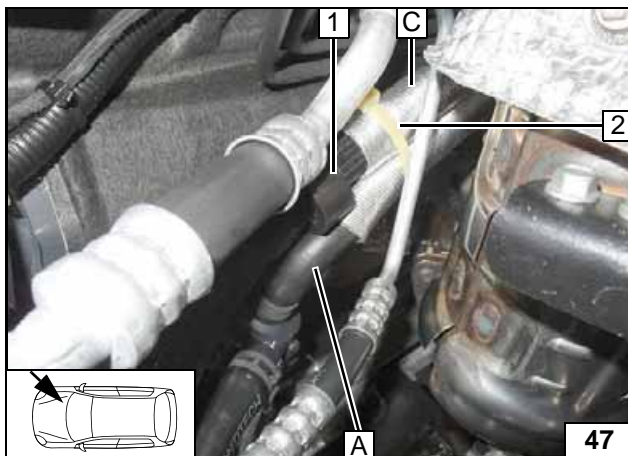

- 1 Position black (sw) rubber isolator
- 2 Long cable tie

**Routing in
engine
compartment**

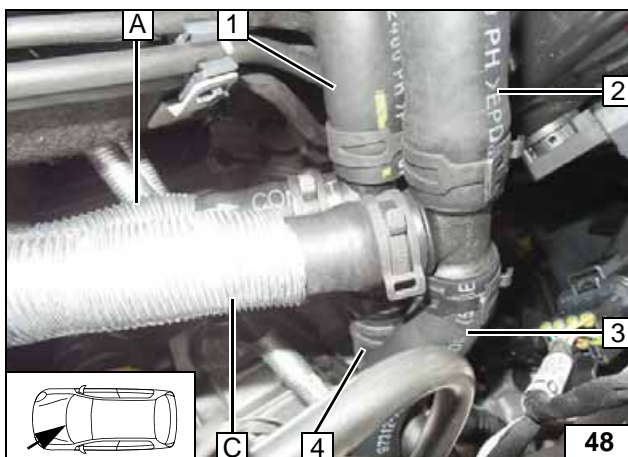

Align hoses. Ensure sufficient distance from neighbouring components, correct if necessary.



- 1 Hose section of heat exchanger inlet
- 2 Hose section of heat exchanger outlet
- 3 Engine inlet hose section
- 4 Engine outlet hose section

**Connecting
check valve
and T-piece**

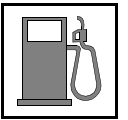

Fuel



Open the vehicle's fuel tank cap, ventilate the tank and then re-close the tank lock.

Catch any fuel running off in an appropriate container.

Route fuel line and metering pump wiring harness so that they are protected against stone impact. Unless specified otherwise, always fasten using cable ties.



Provide rub protection for fuel line and wiring harness in areas where there are sharp edges.

The fuel line and wiring harness are routed to the metering pump as shown in the wiring harness routing diagram.

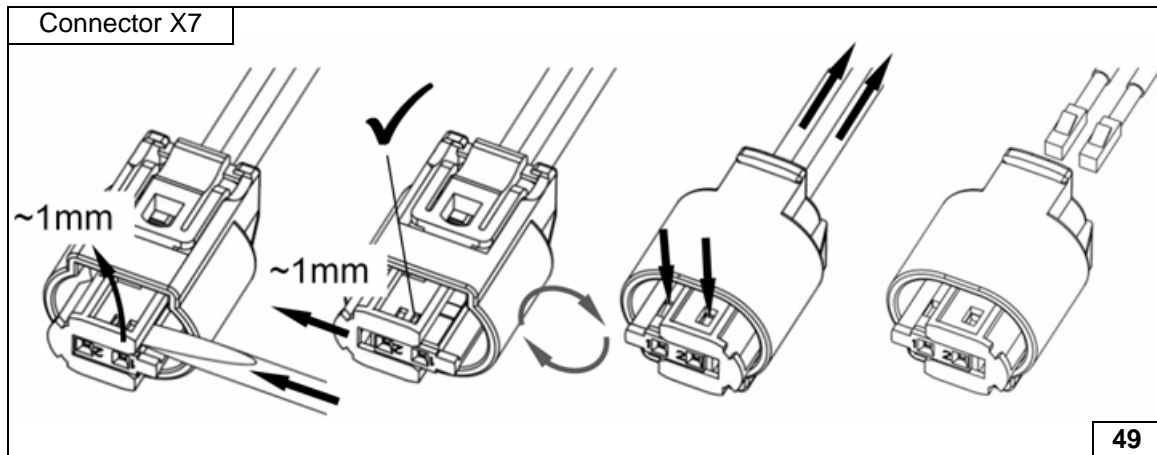

Dismantling metering pump connector

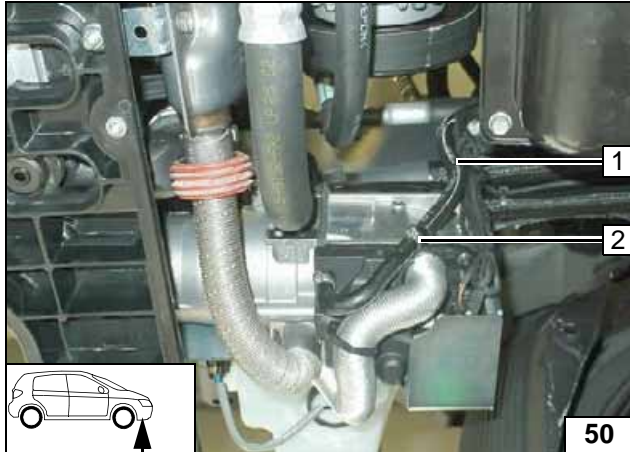

- 1 Fuel line in 10 mm dia., 250mm long corrugated tube
- 2 10mm dia. clamp

Connect-ing heater

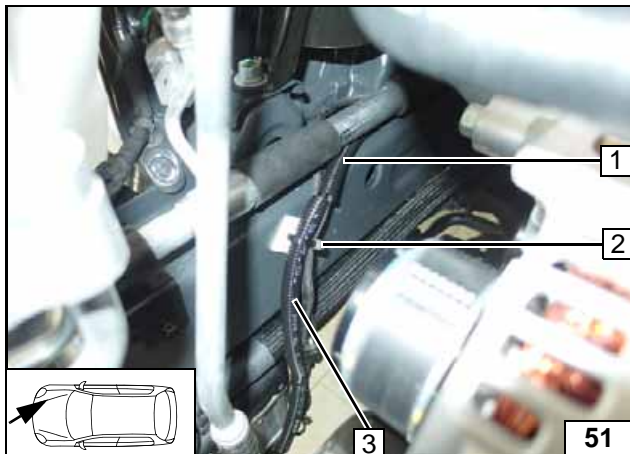

- 1 Fuel line and wiring harness of metering pump in 10mm dia. corrugated tube
- 2 Tighten cable tie
- 3 Fuel line in 250mm long corrugated tube

Routing lines

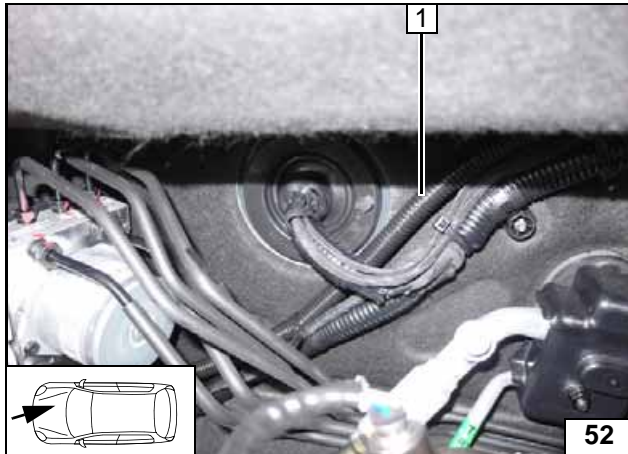
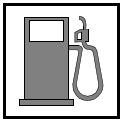

Route fuel line and wiring harness of metering pump in 10mm dia. corrugated tube 1 along original vehicle wiring harness to the right side of the vehicle.



Routing lines



Route wiring harness of metering pump and fuel line in 10mm dia. corrugated tube 1 to the underbody along original vehicle lines.



Routing lines

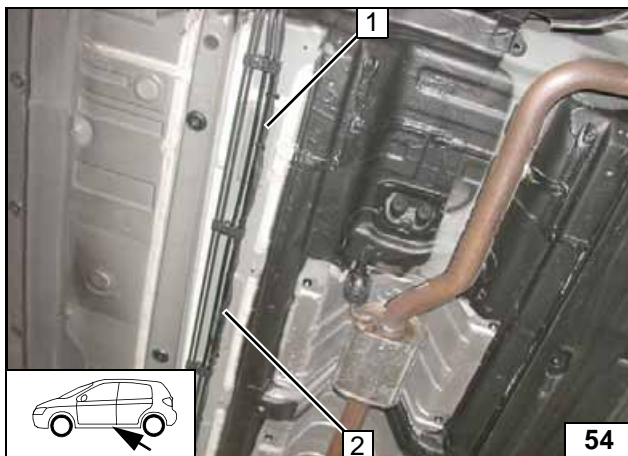

- 1 Fuel line
- 2 Metering pump wiring harness

Routing lines

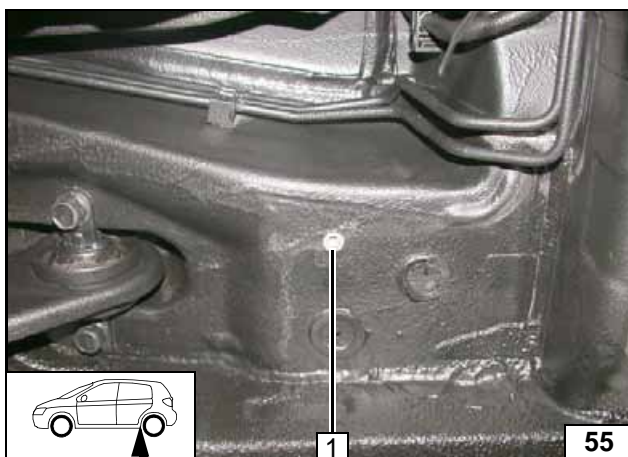

- 1 Rivet nut, existing hole

Installing rivet nut

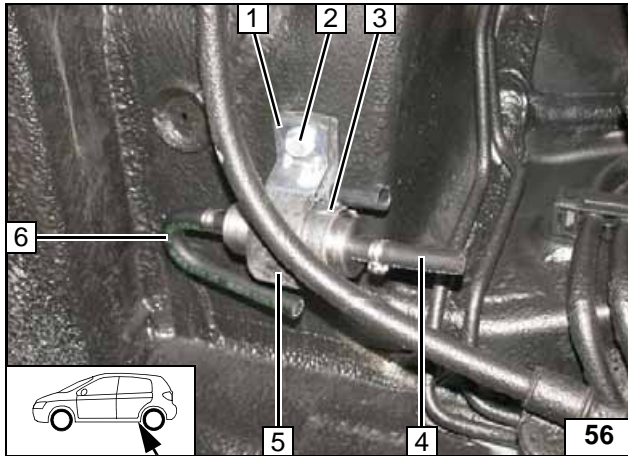
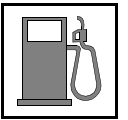

- 1 Support angle bracket
- 2 M6x25 bolt
- 3 Metering pump
- 4 Hose section, 10mm dia. clamp
- 5 Metering pump mount
- 6 180° moulded hose, 10mm dia. clamp



Installing metering pump

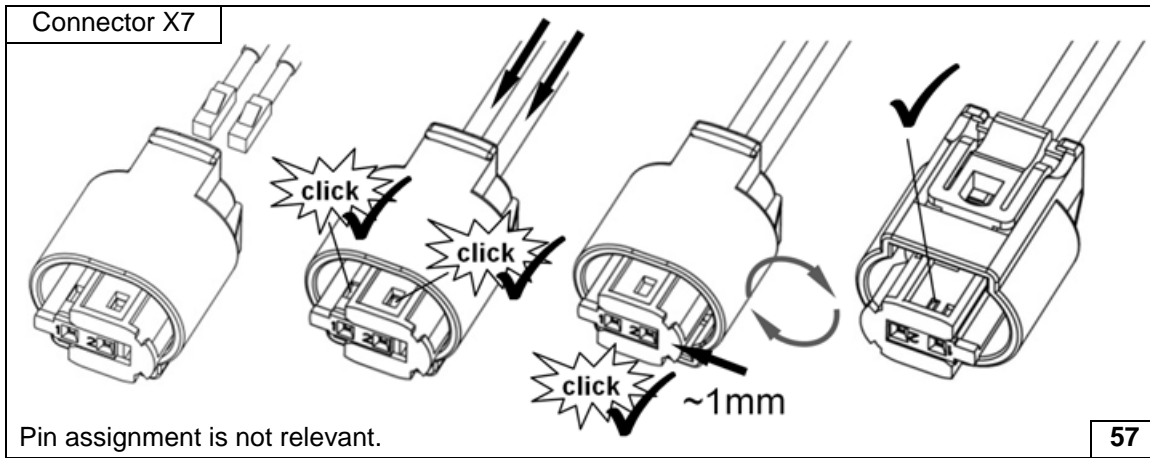

Pin assignment is not relevant.

Completing metering pump connector

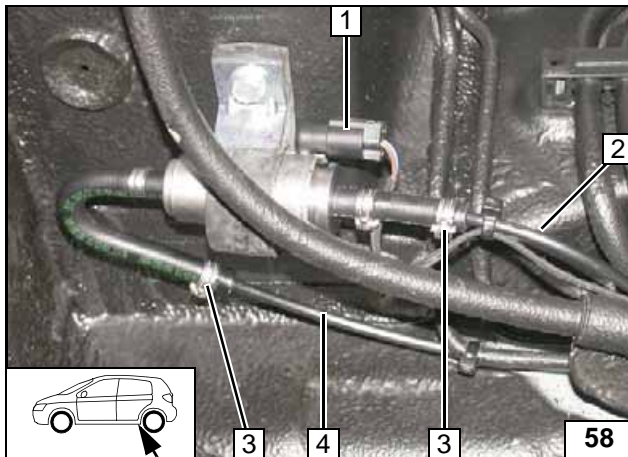

Check the position of the components; adjust if necessary. Check that they have freedom of movement.

- 1 Wiring harness of metering pump, connector X7 mounted
- 2 Fuel line of heater
- 3 10mm dia. clamp [2x]
- 4 Fuel line of FuelFix



Connecting metering pump

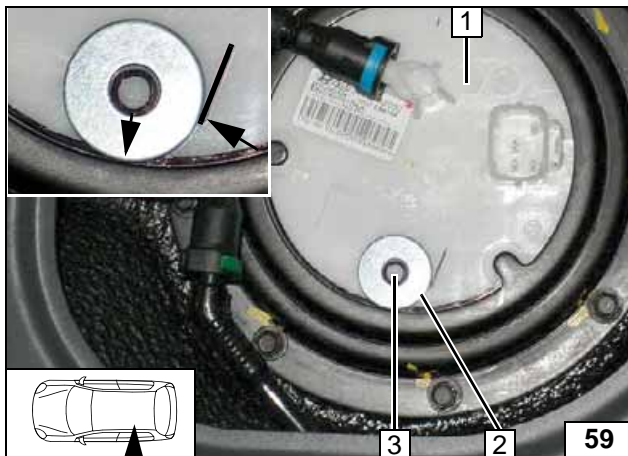

Installing FuelFix

Work steps F1 and F2.

- 1 Fuel tank sending unit
- 2 Position washer with outer dia. $d_a = 21.6\text{mm}$ as template against the raised parts.
- 3 Hole pattern



Copying hole pattern

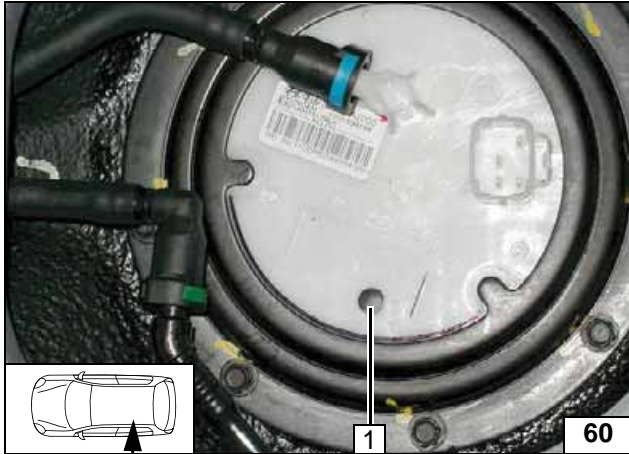
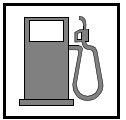

Work step F3.

- 1 Hole made with provided drill

Hole for FuelFix

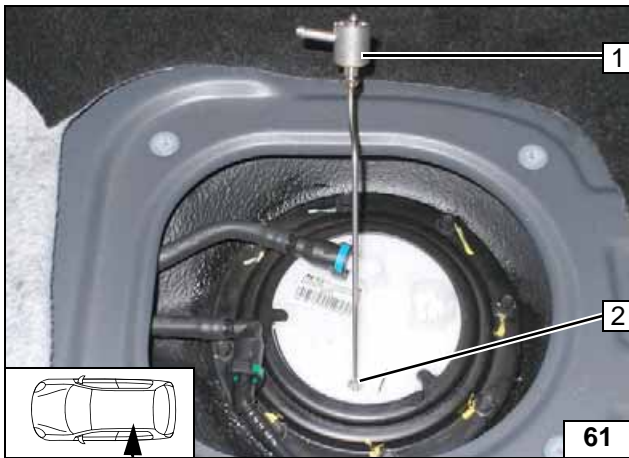

Work steps F4 and F5.

Bend FuelFix 1 according to template and cut to length. Insert into hole 2.



Inserting FuelFix



Work step F5.

Inserting FuelFix



Inserting FuelFix

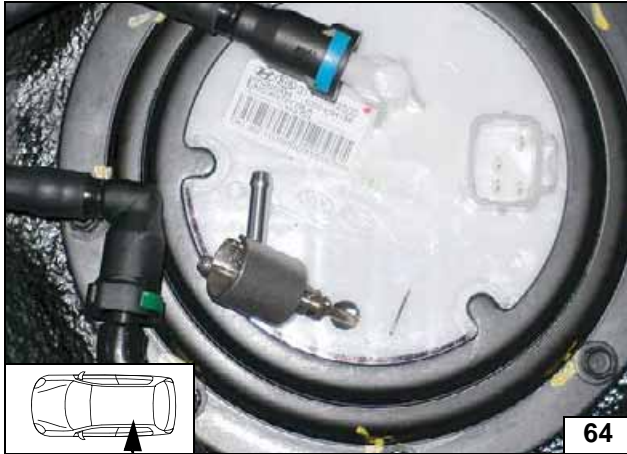
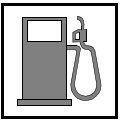

Inserting FuelFix

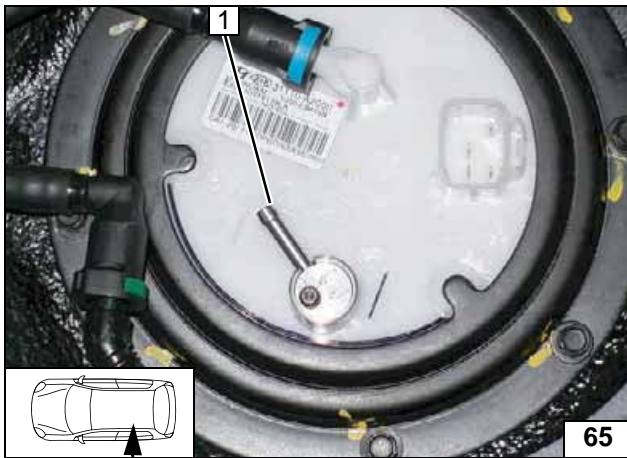

Work steps F5.3 and F5.4.

Align FuelFix 1 as shown.



Aligning FuelFix

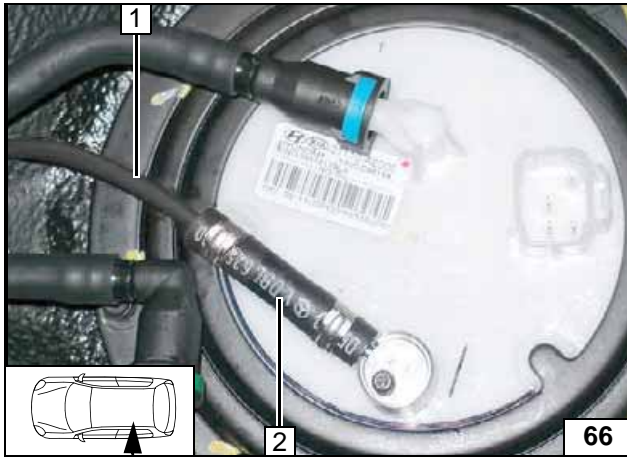

Work step F6.

- 1 Fuel line
- 2 Hose section, 10mm dia. clamp [2x]

Connecting fuel line

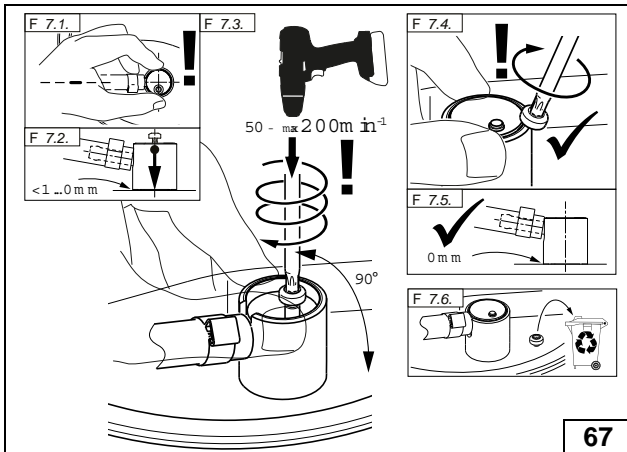

Work step F7.

Installing FuelFix

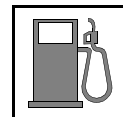

Work step F8.

Checking
firm seating
of FuelFix

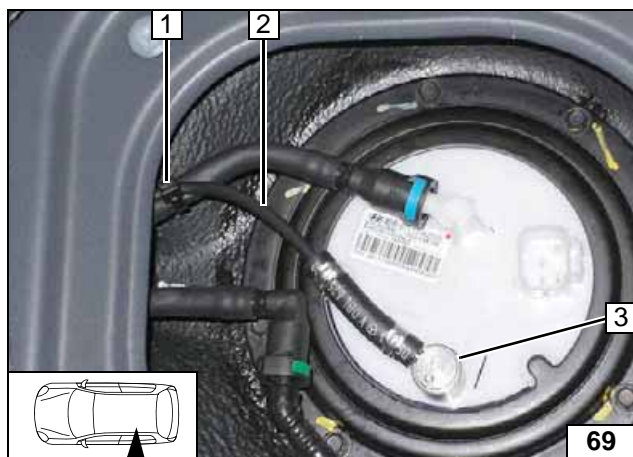

- 1 Cable tie as tension relief
- 2 Fuel line of FuelFix
- 3 FuelFix mounted

Securing
fuel line

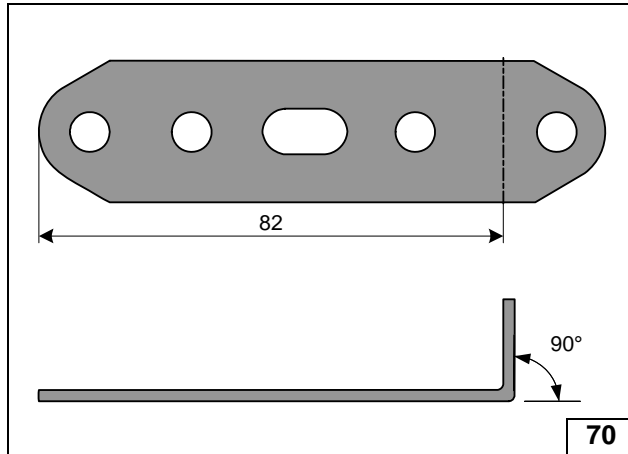
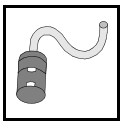

Combustion Air



Bending perforated bracket



- 1 Silencer
- 2 Self-adhesive foam

Preparing silencer



- 1 P-clamp, flanged nut

Routing combustion air pipe s1

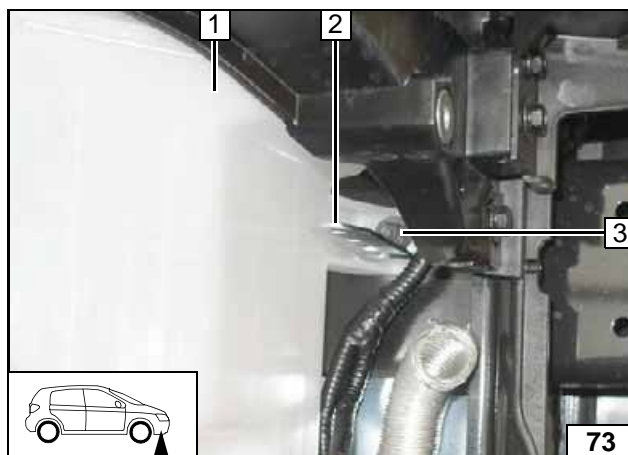

Install washer reservoir 1.

- 2 Perforated bracket
- 3 Original vehicle bolt



Installing perforated bracket

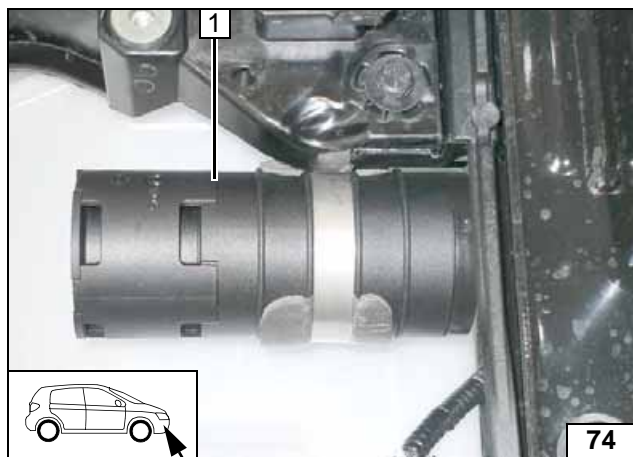
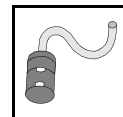

Install silencer 1 onto combustion air pipe s1.

- 1 Silencer



Installing combustion air pipe

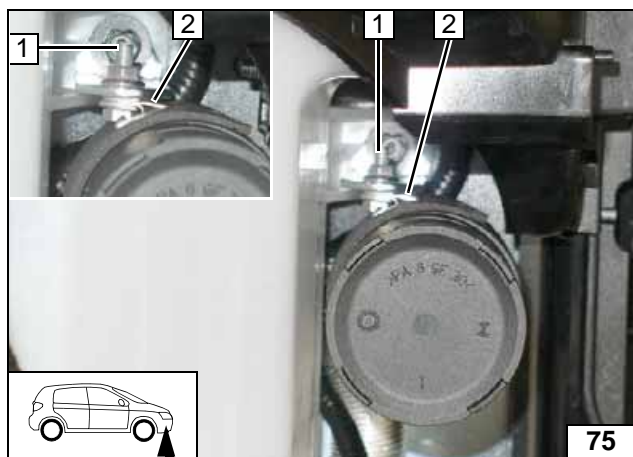

- 1 M6x20 bolt, flanged nut
- 2 51mm dia. clamp



Installing silencer

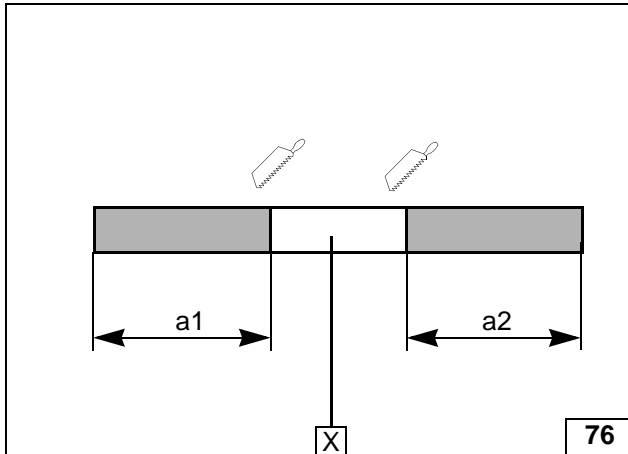
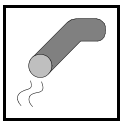

$a1 = 200$
 $a2 = 210$

X=

Preparing exhaust pipe

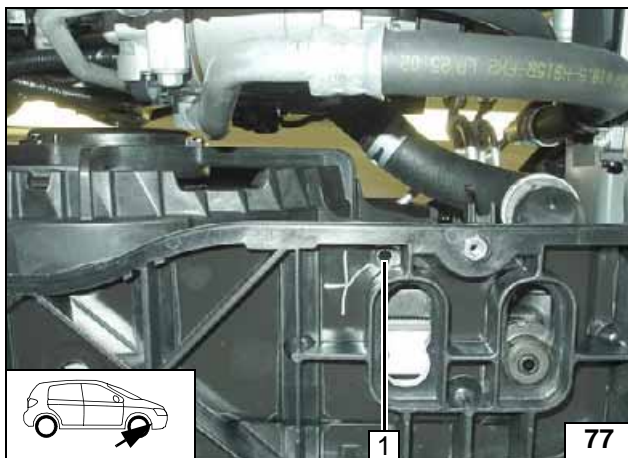

1 7mm dia. hole

Premounting silencer assembly

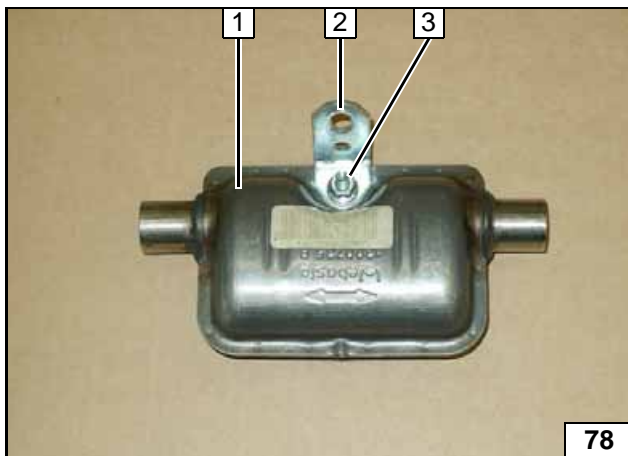

1 Silencer
 2 Angle bracket
 3 M6x16 bolt, flanged nut

Premounting silencer

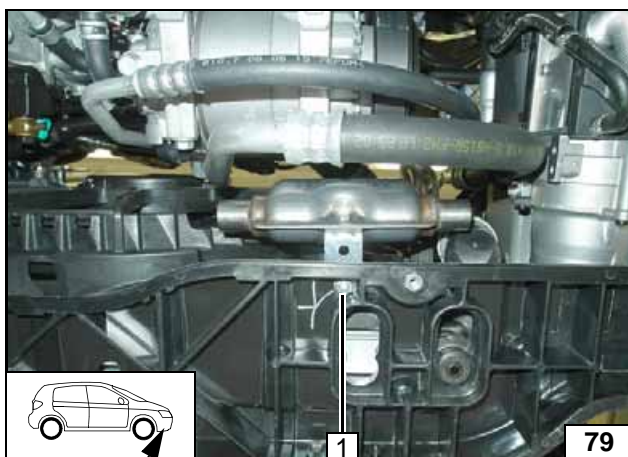

1 M6x20 bolt, flanged nut

Installing silencer

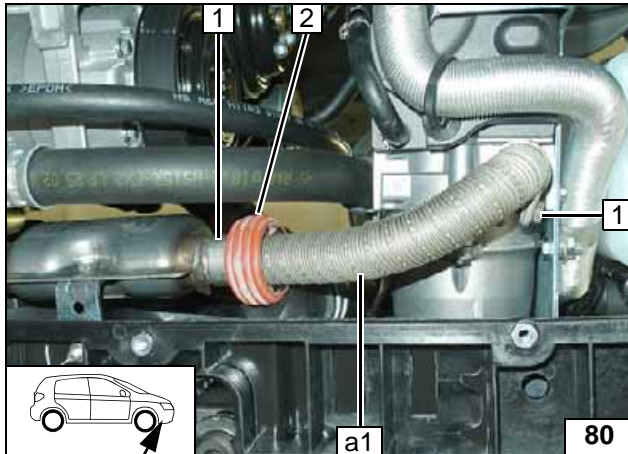
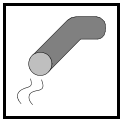

- 1 Hose clamp [2x]
- 2 Spacer bracket

Installing exhaust pipe a1

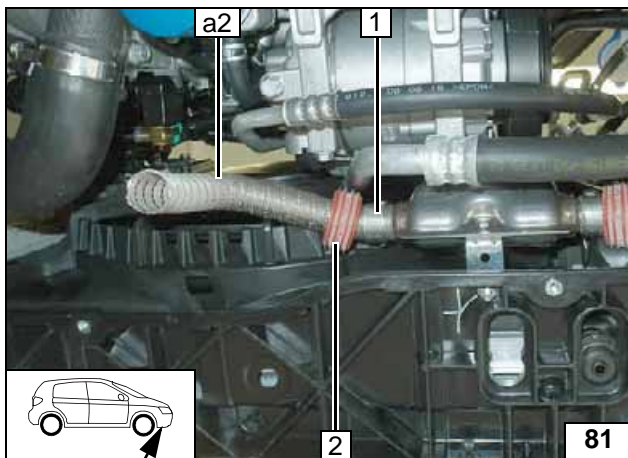

- 1 Hose clamp
- 2 Spacer bracket

Installing exhaust pipe a2

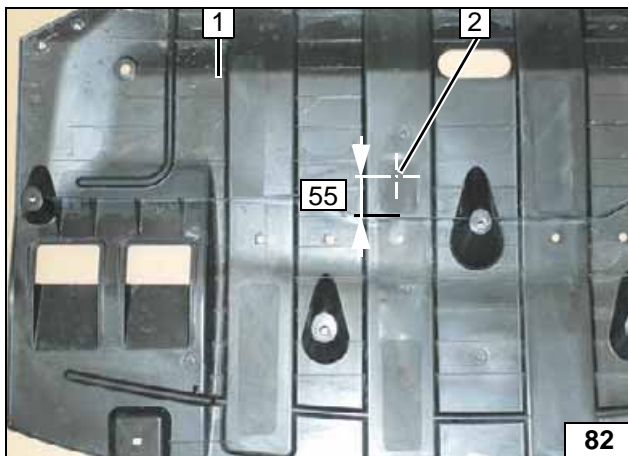

Installing exhaust end fastener

- 1 Underride protection
- 2 Hole (as per work step 1 of the installation instructions)



Hole in underbody protection

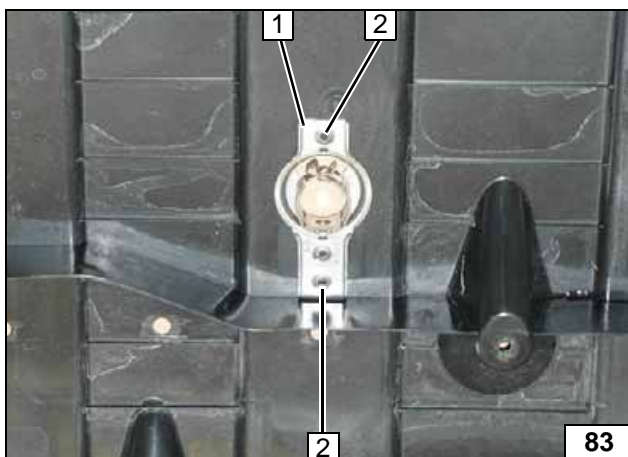

Position exhaust end fastener 1 as per work step 3 of the installation instructions and copy hole pattern 2 [2x]. Hole [2x] as per work step 4 of the installation instructions.



Copying hole pattern

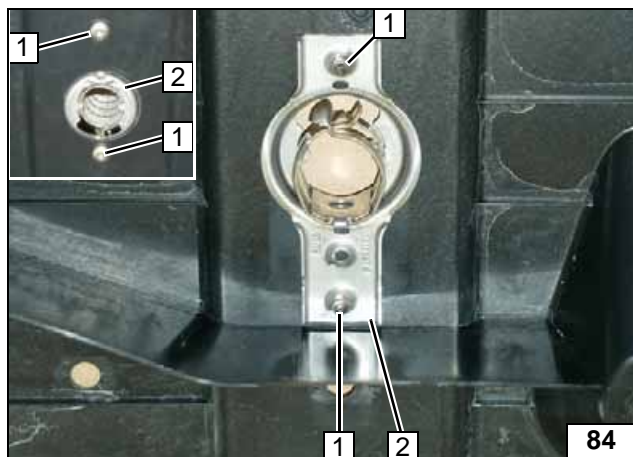
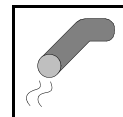

- 1 5x13 self-tapping screw [2x] as per work step 5 of the installation instructions
- 2 Exhaust end fastener



Installing exhaust end fastener

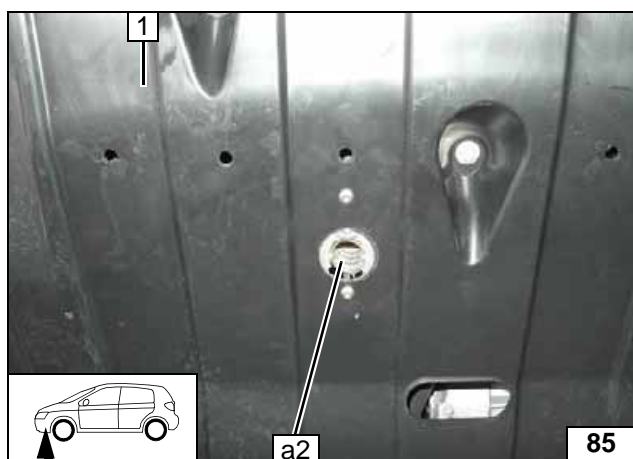

Install bumper. Install underride protection
1. Exhaust pipe a2 as per work steps 6 - 8 of the installation instructions.



Installing exhaust pipe a2

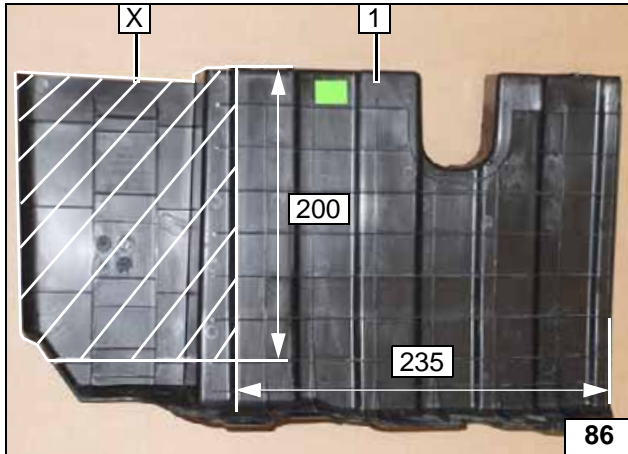
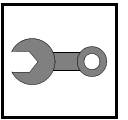

Final Work

1 Lateral engine compartment trim on the right

X =



Cutting out engine compartment trim

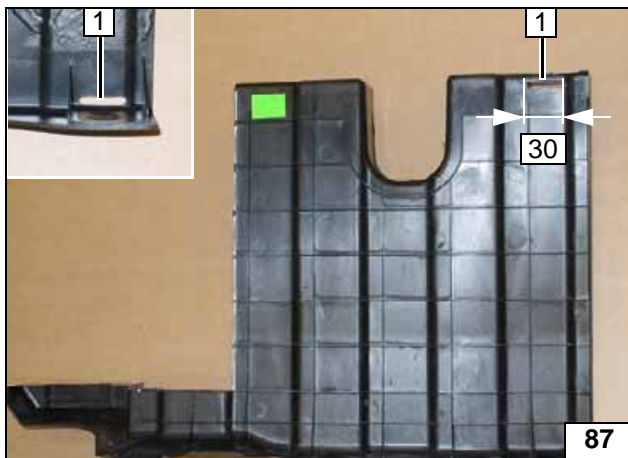

Make a slot for the perforated bracket at position 1 as shown.



Making oblong hole

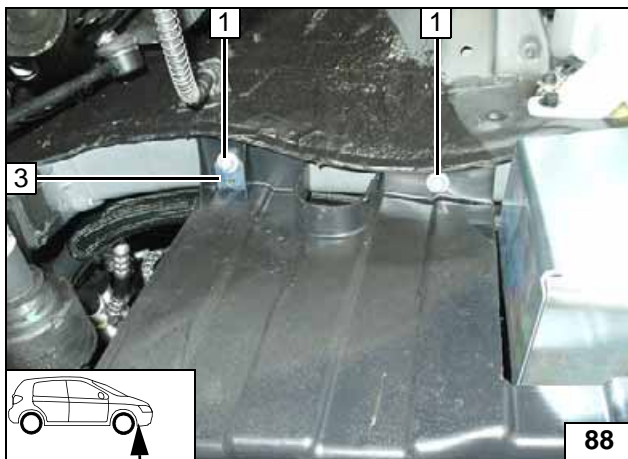

Install perforated bracket 3 at position 1 (see next figure).

1 Original vehicle bolt [2x]



Installing engine compartment trim

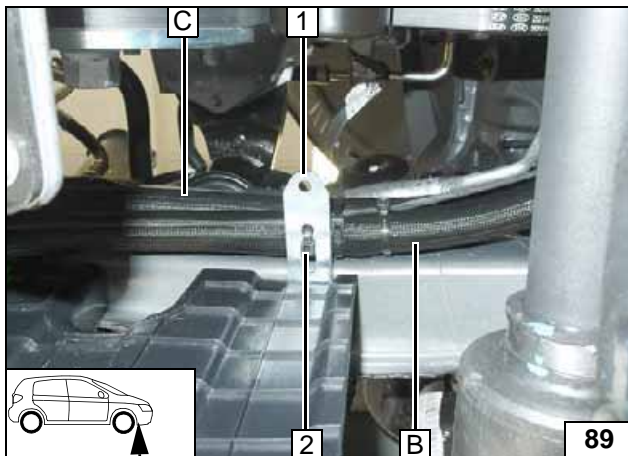

1 Perforated bracket
2 Cable tie

Securing hoses B and C

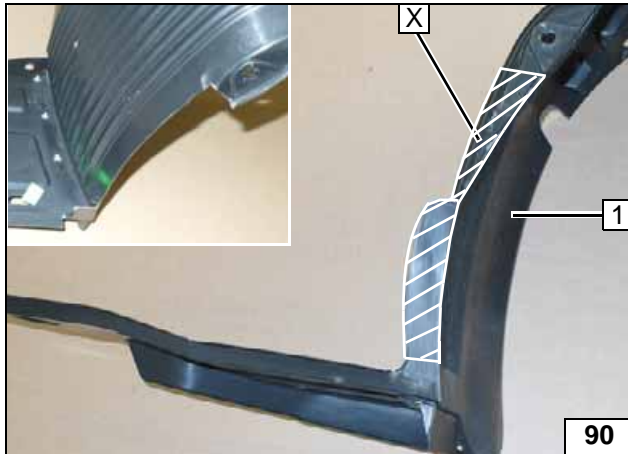
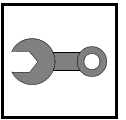

1 Wheel-well inner panel on the right

X = 

**Cutting out
wheel-well
inner panel**

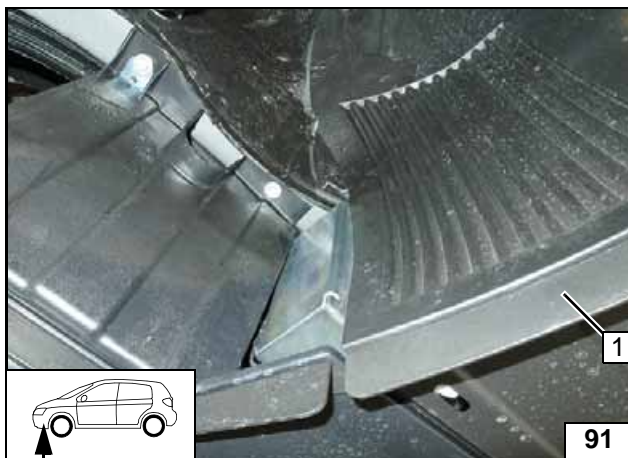

Install wheel-well inner panel on the right
1 as shown.



**Installing
wheel-well
inner panel**



Reassemble the components in reverse order. Check all hoses, clamps and all electrical connections for firm seating. Insulate and tie back all loose lines. Only use manufacturer-approved coolant. Spray the heater components with anti-corrosion wax (Tectyl 100K).

- **Connect the battery.**
- **Fill and bleed the coolant circuit according to the vehicle manufacturer's specifications.**
- **Program MultiControl CAR, teach Telestart transmitter.**
- **For initial startup and function check, please see installation instructions.**
- **Make settings on A/C control panel according to the 'Operating Instructions for End Customer'.**
- **Place the 'Switch off parking heater before refuelling' caution label near the filler neck.**



Webasto Thermo & Comfort SE
Postfach 1410
82199 Gilching
Germany
Internet: www.webasto.com
Technical Extranet:
<http://dealers.webasto.com>

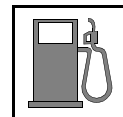

FuelFix Template

Top view

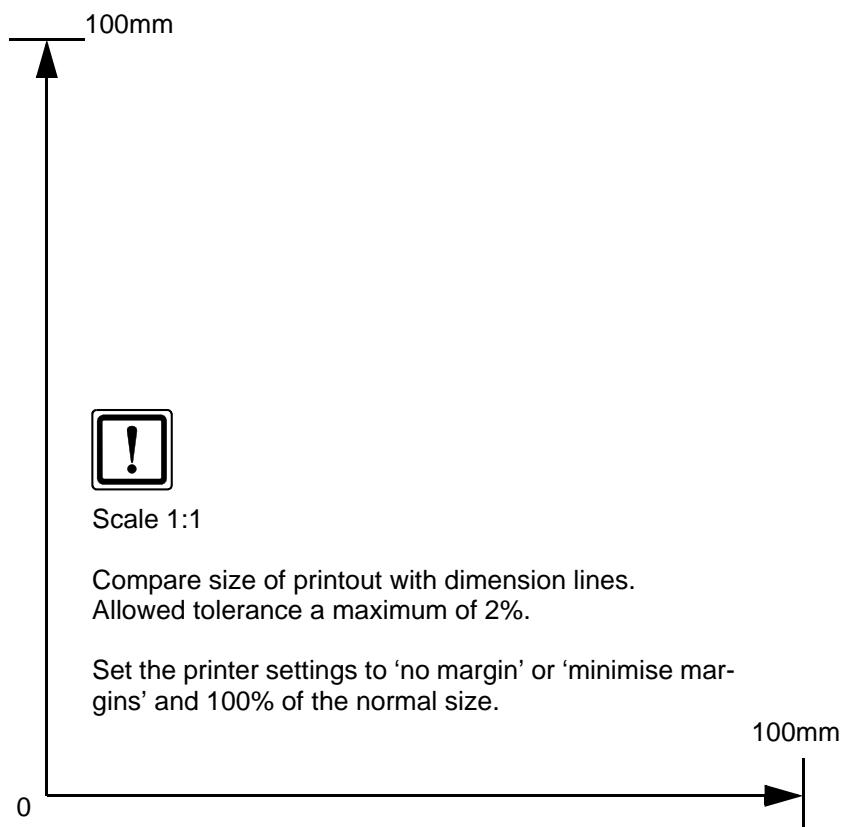
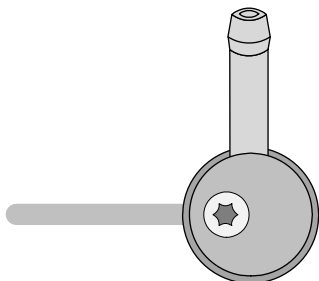

Operating Instructions for Automatic Air-Conditioning

Please remove page and add to the vehicle operating instructions.

Note:

We recommend matching the heating time to the driving time.
Heating time = driving time

Example:

For a driving time of approx. 20 min. (in one direction), we recommend not exceeding a switch-on time of 20 min.

Passenger compartment monitoring, if installed, must be deactivated in addition to the vehicle settings for the heating operation.

For instructions on deactivation, please refer to the operating instructions of the vehicle.

Before parking the vehicle, make the following settings:



- 1 Set temperature on both sides to 'HI'
- 2 Air outlet faces 'upward'
- 3 Set fan to level '2', or max.'3'



A/C control panel

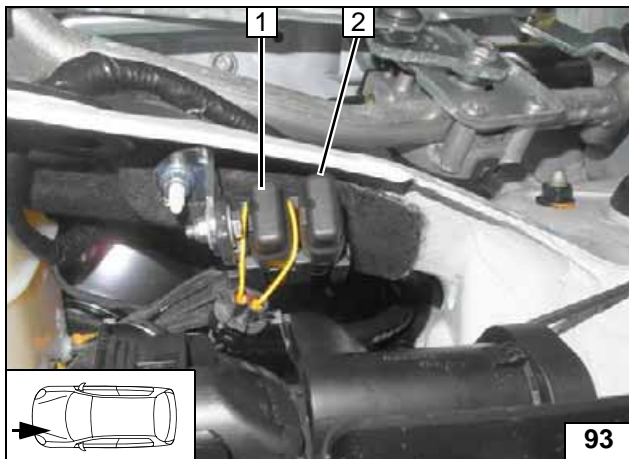

- 1 20A heater fuse F1
- 2 30A main fuse F2 of passenger compartment

Engine compartment fuses

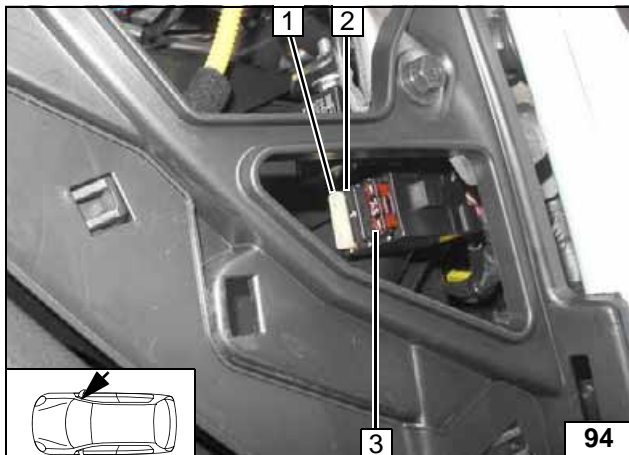

- 1 25A fan fuse F4
- 2 1A heater control fuse F3
- 3 7.5A A/C control panel fuse F5

Passenger compartment fuses