



Water Heater

Thermo Top Evo Parking Heater



With FuelFix

Installation Documentation Seat Ibiza

Validity

Manufacturer	Model	Type	EG BE No. / ABE
Seat	Ibiza	6P1	e9 * 2001 / 116 * 0067 * ...

Motorisation	Fuel	Transmission type	Output in kW	Displacement in cm ³	Engine code
1.0 MPI	Petrol	5-speed SG	55	999	CHYB
1.2 TSI	Petrol	5-speed SG	66	1197	CJZC
1.2 TSI	Petrol	6-speed SG	81	1197	CJZD
1.4 TDI	Diesel	5-speed SG	66	1422	CUSB

SG = manual transmission

From model year 2016

Left-hand drive vehicle

Verified equipment variants: Manual / automatic air-conditioning system
Halogen front fog lights
LED daytime running lights
Euro 6

Not verified: Passenger compartment monitoring
Headlight washer system
Xenon headlights
Alarm system

Total installation time: approx. 8.5 hours

Seat Ibiza

Table of Contents

Validity	1	Preparing Installation Location	16
Necessary Components	2	Preparing Heater	18
Installation Overview	2	Installing Heater	19
Information on Total Installation Time	2	Exhaust Part 1	22
Information on Operating and Installation Instructions	3	Coolant Circuit	23
Information on Validity	4	Coolant Circuit for Diesel Vehicles	30
Technical Information	4	Combustion Air	36
Explanatory Notes on Document	4	Fuel	37
Preliminary Work	5	FuelFix Installation for Petrol Vehicles	40
Heater Installation Location	5	FuelFix Installation for Diesel Vehicles	45
Preparing Electrical System	6	Exhaust Part 2	49
Electrical System	9	Final Work	54
Manual Air-Conditioning Fan Controller	10	FuelFix Template for Petrol Vehicle	55
Automatic Air-Conditioning Fan Controller	12	FuelFix Template for Diesel Vehicle	56
MultiControl CAR Option	14	Operating Instructions for Manual Air-Conditioning	57
Remote Option (Telestart)	14	Operating Instructions for Automatic Air-Conditioning	58
ThermoCall Option	15		

Necessary Components

- Basic delivery scope of Thermo Top Evo according to price list
- Installation kit with FuelFix for Seat Ibiza 2016 Petrol and diesel: **1324605A**
- Additionally required in case of automatic air-conditioning: Additional kit AAC for Skoda Fabia 2015 **1323164_**
- Heater control in accordance with price list and upon consultation with end customer
- In case of Telestart, indicator lamp in accordance with price list and in consultation with end customer
- In case of MultiControl CAR installation: MultiControl installation frame: **9030077_**

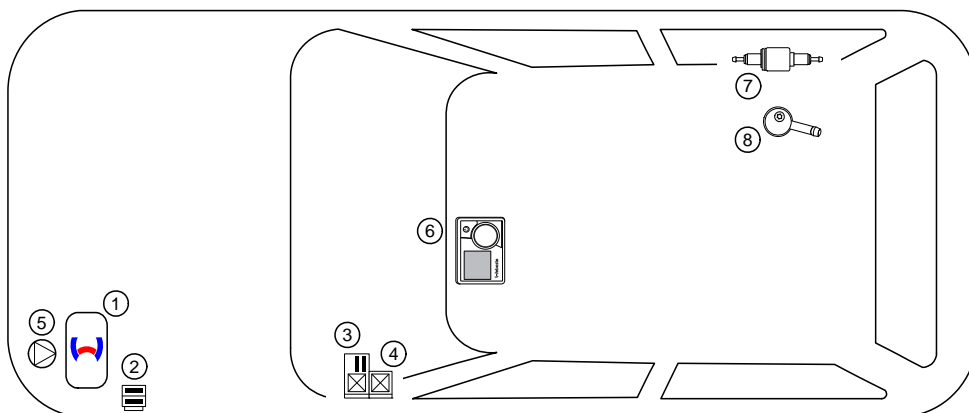
Installation instructions:

- Arrange for the vehicle to be delivered with the tank only about ¼ full.
- The installation location of the push button in case of Telestart or Thermo Call should be confirmed with the end customer.
- Depending on the space required and the vehicle manufacturer's instructions, we recommend the use of a vehicle battery with a higher electrical capacity.

Installation Overview

Legend:

1. Heater
2. Engine compartment fuse holder
3. Passenger compartment relay and fuse holder
4. PWM GW (only in case of automatic air-conditioning)
5. Circulating pump
6. MultiControl CAR
7. Metering pump
8. FuelFix



Information on Total Installation Time

The total installation time includes the time needed for mounting and demounting the vehicle-specific components, the heater specific installation time and all other times required for the system integration and initial start-up of the heater. The total installation time may vary for vehicle equipment other than provided.

Information on Operating and Installation Instructions

1 Important information (not complete)

1.1 Installation and repair



The improper installation or repair of Webasto heating and cooling systems can cause fire or the leakage of deadly carbon monoxide, leading to serious injury or death.



To install and repair Webasto heating and cooling systems you need to have completed a special company training course and have the appropriate technical documentation, special tools and special equipment.



Installation and repair may ONLY be carried out by persons trained and certified in a Webasto training course. NEVER try to install or repair Webasto heating or cooling systems if you have not completed a Webasto training course, you do not have the necessary technical skills and you do not have the technical documentation, tools and equipment available to ensure that you can complete the installation and repair work properly.

Only use genuine Webasto parts. See the Webasto air and water heaters accessories catalogue for this purpose.

1.2 Operation

To ensure safe operation, we recommend having the heater checked every two years by an authorised Webasto dealer, especially when used over a long period and/or under extreme environmental conditions.

Do not operate the heater in closed rooms due to the danger of poisoning and suffocation.

Always switch off the heater before refuelling.

The heater may only be used with the prescribed fuel diesel (DIN EN 590) or petrol (DIN EN 228).

The heater may not be cleaned with a high-pressure cleaner.

1.3 Please note

ALWAYS follow all Webasto installation and operating instructions and observe all warnings.

To become familiar with and understand all functions and properties of the heater, the operating instructions must be read carefully and observed at all times.

For proper, safe installation and repair work, the installation instructions with all warnings and safety information must be carefully read and observed at all times. Please always contact a workshop authorised by Webasto for all installation and repair work.

Important

Webasto shall assume no liability for defects, damage and injuries resulting from a failure to observe the installation, repair and operating instructions of the information contained in them.

This liability exclusion particularly applies to improper installations and repairs, installations and repairs by untrained persons or in the case of a failure to use genuine spare parts.

The liability due to culpable disregard to life, limb or health and due to damage or injuries caused by a wilful or reckless breach of duty remain unaffected, as does the obligatory product liability.

Installation should be carried out according to the general, standard rules of technology. Unless specified otherwise, fasten hoses, lines and wiring harnesses to original vehicle lines and wiring harnesses using cable ties. Insulate loose wire ends and tie back. Connectors on electronic components have to audibly click into place during installation.

Sharp edges should be fitted with rub protection. Spray unfinished body areas, e.g. drilled holes, with anti-corrosion wax (Tectyl 100K).

Observe the instructions and guidelines of the respective vehicle manufacturer for demounting and mounting vehicle specific components!

The initial startup is to be executed with the Webasto Thermo Test Diagnosis.

When installing a programmable control module (e.g. a PWM Gateway), the corresponding settings must be checked or adjusted.

2 Statutory regulations governing installation

Guidelines	Thermo Top Evo
Heating Directive ECE R122	E1 00 0258
EMC Directive ECE R10	E1 04 5627

Note

The regulations of these guidelines are binding in the scope of the Directive 70/156/EEC and/or 2007/46/EC (for new vehicle models from 29/04/2009) and should also be observed in countries in which there are no special regulations.

Important

Failure to follow the installation instructions will result in the invalidation of the type approval for the heater and therefore invalidation of the general **homologation of the vehicle**.

Note

The heater is licensed in accordance with paragraph 19, section 3, No. 2b of the StVZO (German Road Traffic Licensing Authority).

2.1 Excerpt from ECE regulation 122 (heating system) paragraph 5 for the installation of the heater

Beginning of excerpt.

ANNEX VII

REQUIREMENTS FOR COMBUSTION HEATERS AND THEIR INSTALLATION

1. GENERAL REQUIREMENTS

1.7.1. A clearly visible tell-tale in the operator's field of view shall inform when the combustion heater is switched on or off.

2. VEHICLE INSTALLATION REQUIREMENTS

2.1. Scope

2.1.1. Subject to paragraph 2.1.2, combustion heaters shall be installed according to the requirements of this Annex.

2.1.2. Vehicles of category O having liquid fuel heaters are deemed to comply with the requirements of this Annex.

2.2. Positioning of heater

2.2.1. Body sections and any other components in the vicinity of the heater must be protected from excessive heat and the possibility of fuel or oil contamination.

2.2.2. The combustion heater shall not constitute a risk of fire, even in the case of overheating. This requirement shall be deemed to be fulfilled if the installation ensures an adequate distance to all parts and suitable ventilation, by the use of fire resistant materials or by the use of heat shields.

2.2.3. In the case of M2 and M3 vehicles, the heater must not be positioned in the passenger compartment. However, an installation in an effectively sealed envelope which also complies with the conditions in paragraph 2.2.2 may be used.

2.2.4. The label referred to in paragraph 1.4 or a duplicate, must be positioned so that it can be easily read when the heater is installed in the vehicle.

2.2.5. Every reasonable precaution should be taken in positioning the heater to minimise the risk of injury and damage to personal property.

2.3. Fuel supply

2.3.1. The fuel filler must not be situated in the passenger compartment and must be provided with an effective cap to prevent fuel spillage.

2.3.2. In the case of liquid fuel heaters, where a supply separate to that of the vehicle is provided, the type of fuel and its filler point must be clearly labelled.

2.3.3. A notice, indicating that the heater must be shut down before refuelling, must be affixed to the fuelling point. In addition a suitable instruction must be included in the manufacturer's operating manual.

2.4. Exhaust system

2.4.1. The exhaust outlet must be located so as to prevent emissions from entering the vehicle through ventilators, heated air inlets or opening windows.

2.5. Combustion air inlet

2.5.1. The air for the combustion chamber of the heater must not be drawn from the passenger compartment of the vehicle.

2.5.2. The air inlet must be so positioned or guarded that blocking by rubbish or luggage is unlikely.

2.6. Heating air inlet

2.6.1. The heating air supply may be fresh or recirculated air and must be drawn from a clean area not likely to be contaminated by exhaust fumes emitted either by the propulsion engine, the combustion heater or any other vehicle source.

2.6.2. The inlet duct must be protected by mesh or other suitable means.

2.7. Heating air outlet

2.7.1. Any ducting used to route the hot air through the vehicle must be so positioned or protected that no injury or damage could be caused if it were to be touched.

2.7.2. The air outlet must be so positioned or guarded that blocking by rubbish or luggage is unlikely.

End of excerpt.

In multilingual versions the German language is binding.

Seat Ibiza

Information on Validity

This installation documentation applies to Seat Ibiza Petrol and diesel vehicles - for validity, see page 1 - from model year 2016 and later, assuming technical modifications to the vehicle do not affect installation, any liability claims excluded. Depending on the vehicle version and equipment, modifications may be necessary during installation with respect to this 'installation documentation'.

Vehicle and engine types, equipment variants and other specifications not listed in this installation documentation have not been tested. However, installation according to this installation documentation may be possible.

Technical Information

Special Tools

- Hose clamp pliers for auto-tightening hose clamps
- Hose clamp pliers for Clic hose clamps of type W
- Automatic wire stripper 0.2 - 6mm²
- Crimping pliers for cable lug / tab connector 0.5 - 6mm²
- Torque wrench for 2.0 - 10 Nm
- Hose clamping pliers
- Metric thread-setter kit
- Deep-hole marker
- Webasto Thermo Test Diagnosis with current software

Dimensions

- All dimensions are in mm.

Tightening torque values

- Tightening torque values of 5x13 heater bolts and 5x11 heater stud bolts = 8Nm.
- Tightening torque value of 5x15 water connection piece retaining plate bolt = 7Nm.
- Tighten other bolt connections in accordance with manufacturer's instructions or in accordance with state-of-the-art technology.

Explanatory Notes on Document

You will find an identification mark on the outside top right corner of the page in question to provide you with a quick overview of the individual working steps.

Special features are highlighted using the following symbols:

Mechanical System



Electrical System



Coolant Circuit



Combustion Air



Fuel



Exhaust Gas



Software



Specific risk of damage to components.



Specific risk due to electrical voltage.



Specific risk of injury or fatal accidents.



Specific risk of fire or explosion.



Reference to the manufacturer's vehicle-specific documents or to the general installation instructions of Webasto components.



Reference to a special technical feature.



The arrow in the vehicle icon indicates the position on the vehicle and the viewing angle.



Tightening torque according to the manufacturer's vehicle-specific documents.



Seat Ibiza

Preliminary Work

Vehicle



- Open the fuel tank cap.
- Ventilate the fuel tank.
- Close the fuel tank cap again.
- Depressurise the cooling system.
- Disconnect and completely remove the battery together with the carrier.
- Remove the windscreen wiper.
- Remove the coolant reservoir cap.
- Remove the partition wall of the coolant reservoir.
- Remove the windscreen wiper motor.
- Remove the air filter and intake hose (only in case of 1.2 TSI)
- Remove the left front wheel.
- Remove the wheel-well inner panel on the left.
- Remove the horn (one or two can be present) with the bracket.
- Remove the lateral instrument panel trim on the left and right.
- Completely remove the glove box.
- Remove the underride protection.
- Remove the right vehicle underbody trim.
- Fold up the seat surface of the rear bench seat.
- Open the tank-fitting service lid.



Heater

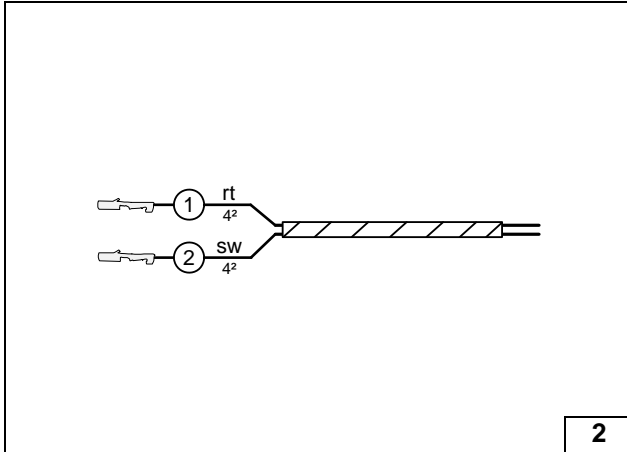
- Remove years that do not apply from the type and duplicate label.
- Attach the duplicate label (type label) visibly in the appropriate place in the engine compartment.



Heater Installation Location

- 1 Heater

Installation location



2

Preparing Electrical System

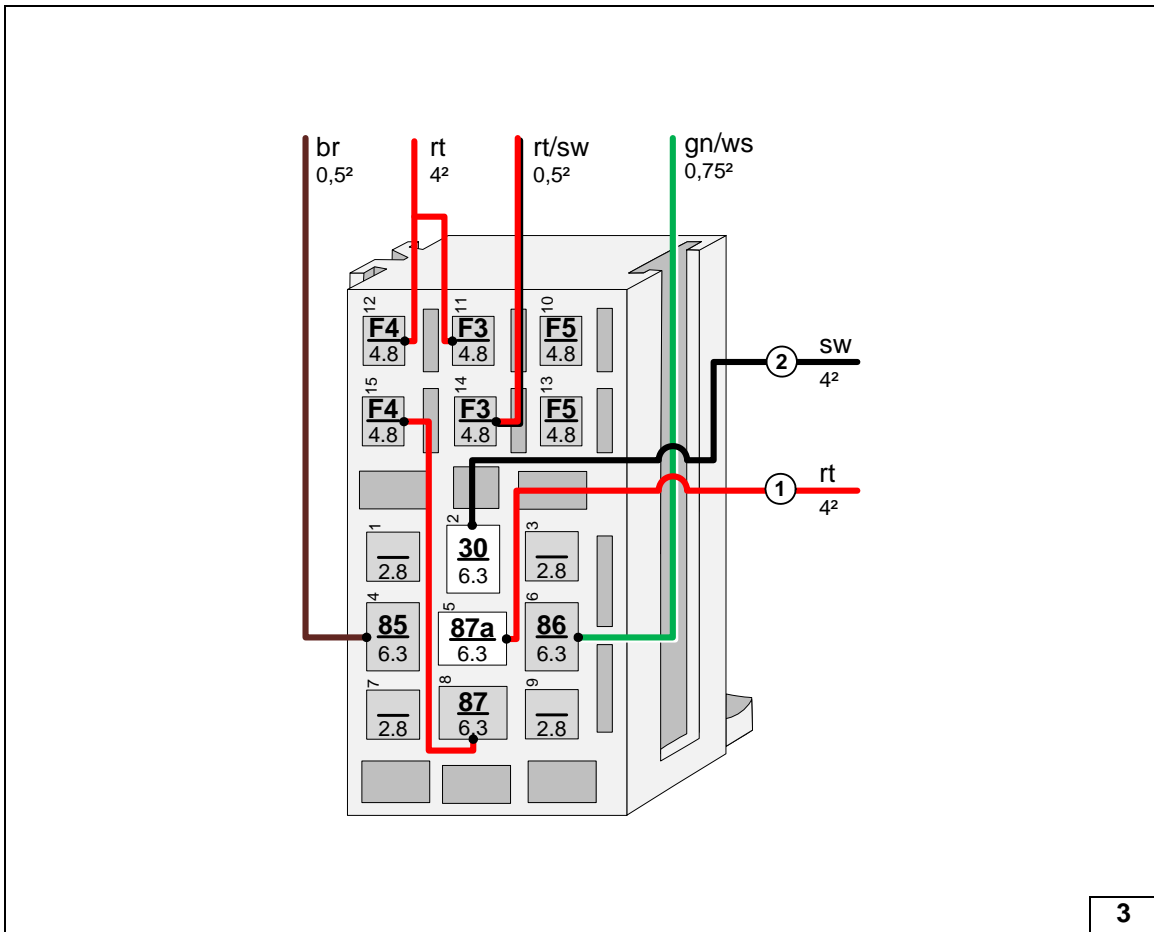
Wire sections retain their numbering in the entire document.

Produce all following electrical connections as shown in the wiring diagram.

Manual air-conditioning

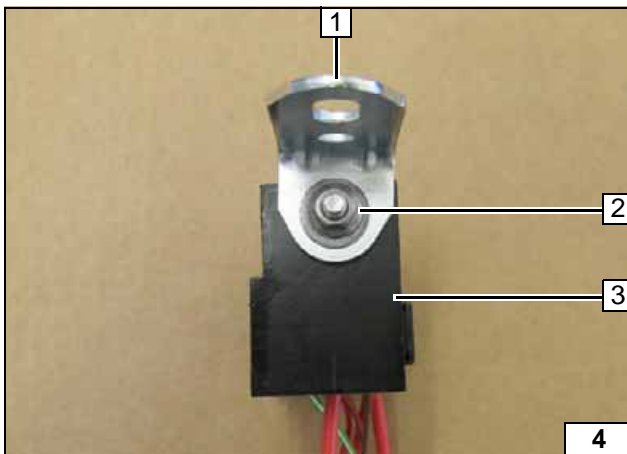
- ① Red (rt) wire of fan wiring harness
- ② Black (sw) wire of fan wiring harness

Assigning wires



3

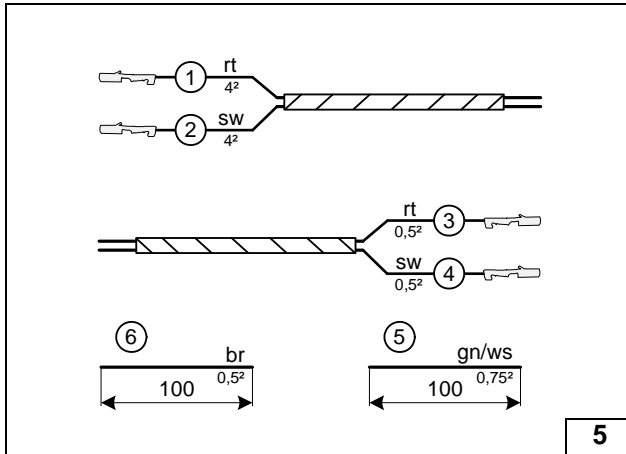
Connecting wires to passenger compartment relay and fuse holder



4

- 1 Angle bracket
- 2 Install M5x16 bolt, large diameter washer [2x], nut loosely
- 3 Passenger compartment relay and fuse holder

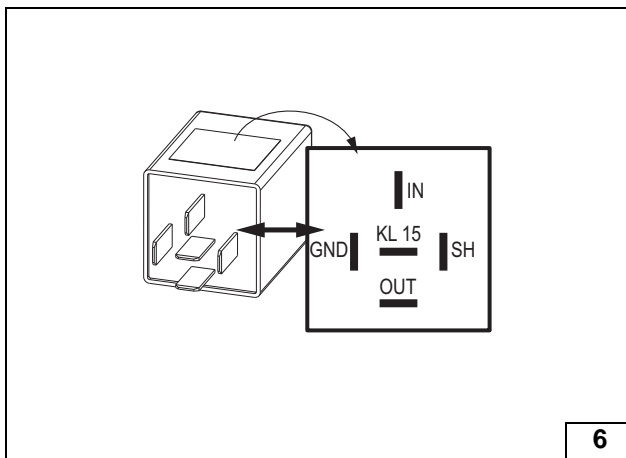
Preparing passenger compartment relay and fuse holder



Automatic air-conditioning

- ① Red (rt) wire of fan wiring harness
- ② Black (sw) wire of fan wiring harness
- ③ Red (rt) wire from wiring harness of PWM control
- ④ Black (sw) wire from wiring harness of PWM control

Assigning wires

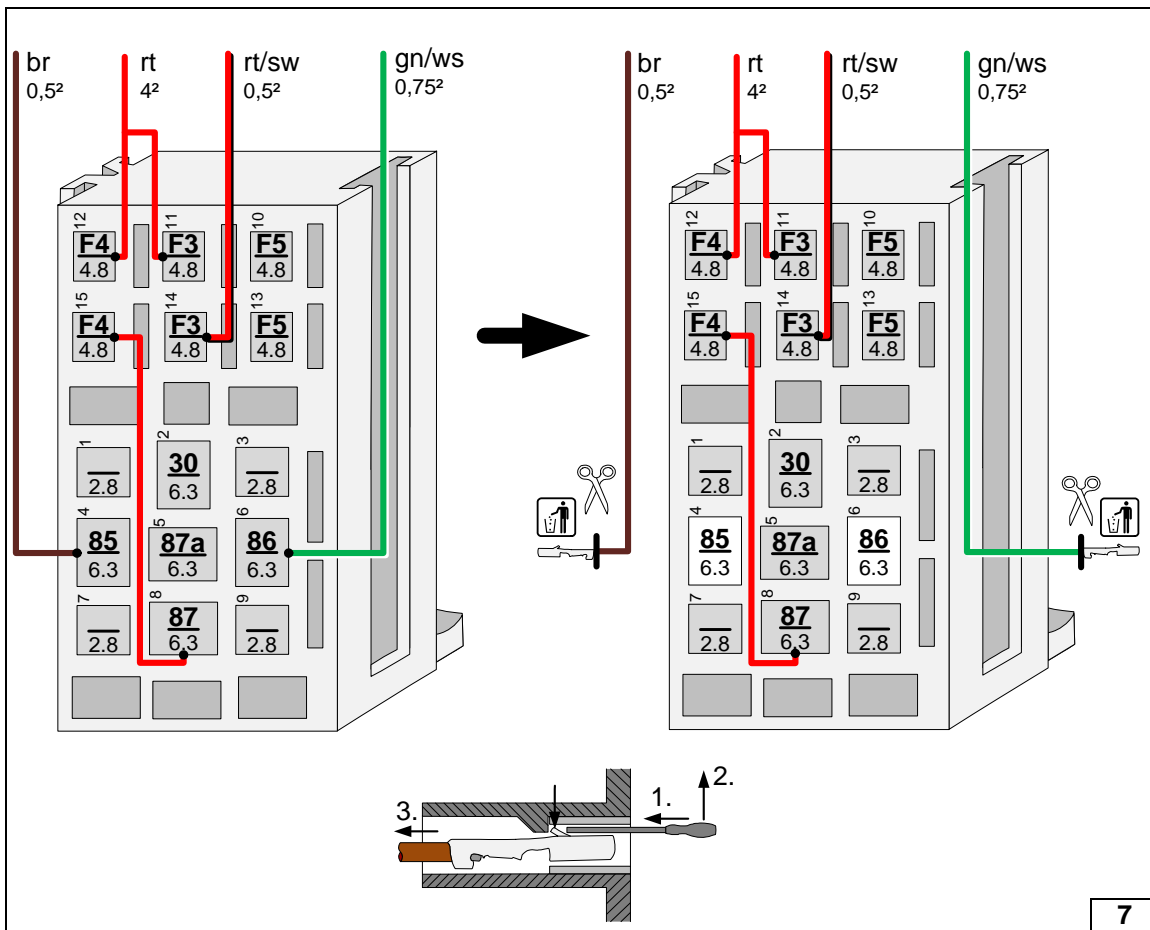


Check the PWM Gateway settings when starting up the heater and adjust if necessary.

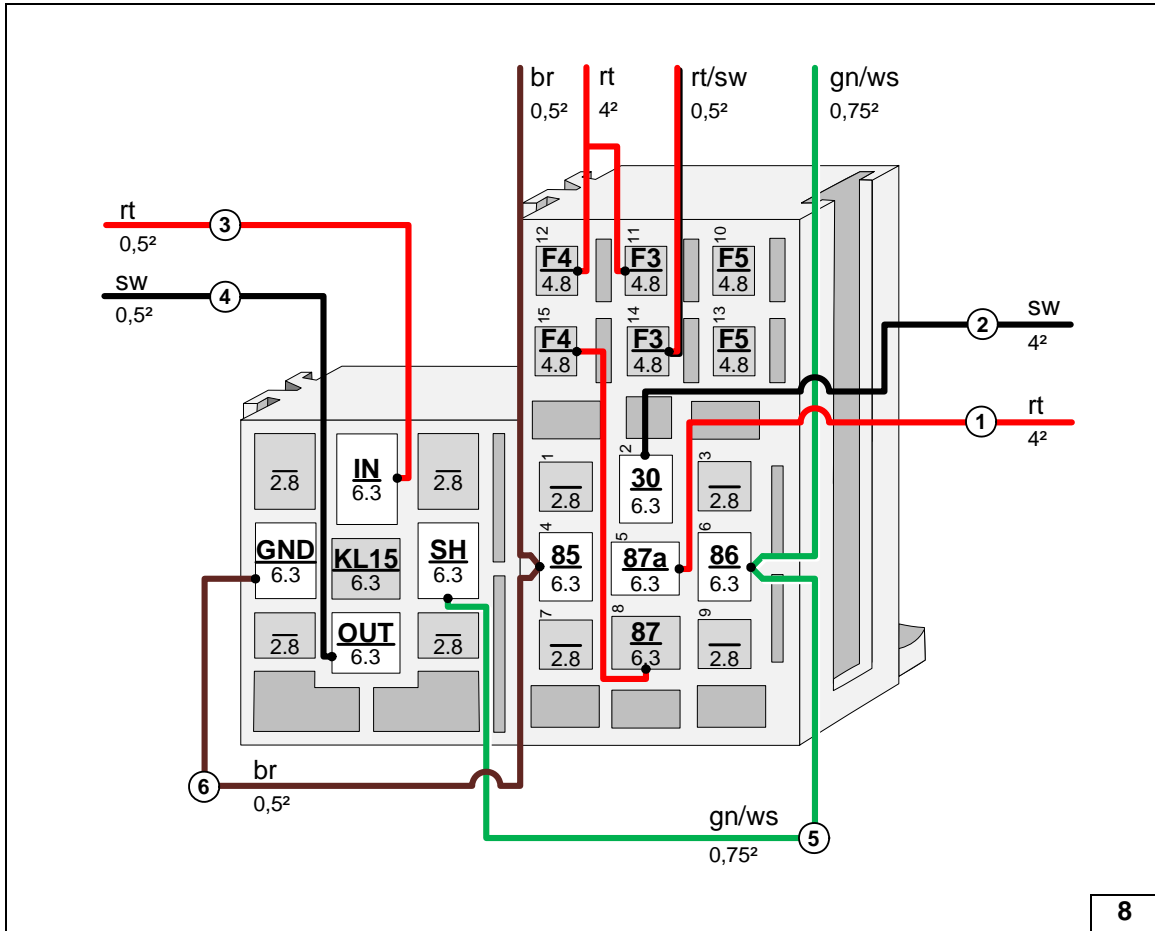
Settings:

- Duty cycle: 100% (DC)
- Frequency: not relevant
- Voltage: 3.3V
- Function: High side

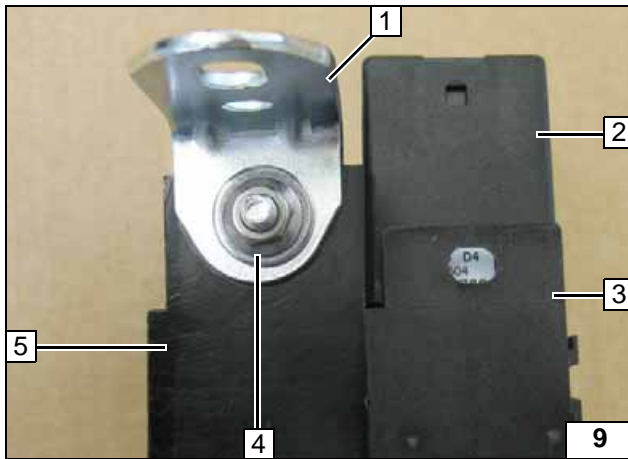
View of PWM GW



Preparing passenger compartment relay and fuse holder

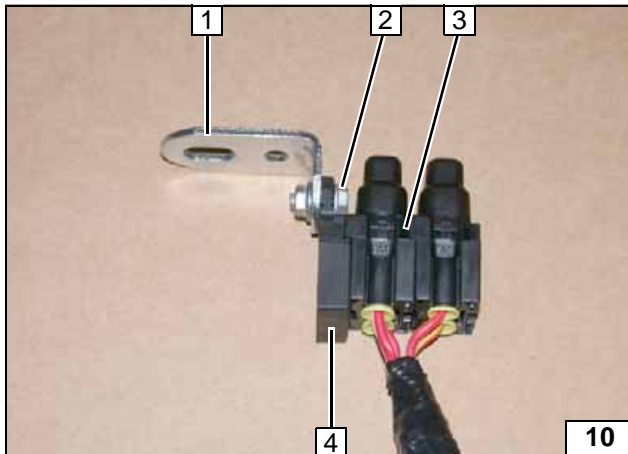


Interlocking socket of PWM GW and passenger compartment relay and fuse holder and connecting wires



- 1 Angle bracket
- 2 PWM GW inserted
- 3 PWM GW socket
- 4 Install M5x16 bolt, large diameter washer [2x], nut loosely
- 5 Passenger compartment relay and fuse holder

Preparing passenger compartment relay and fuse holder



All vehicles

- 1 Angle bracket
- 2 Install M5x16 bolt, large diameter washer [2x], nut loosely
- 3 Fuses F1-2
- 4 Retaining plate of fuse holder

Preparing engine compartment fuse holder

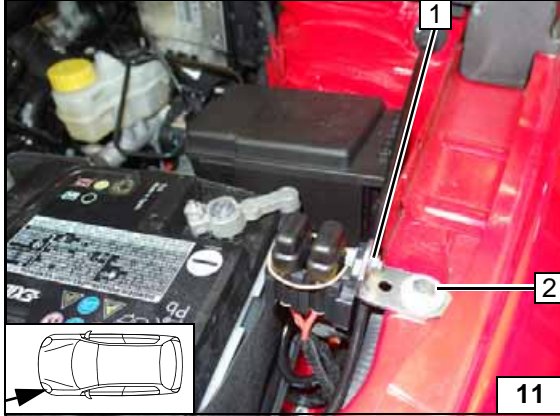


Electrical System



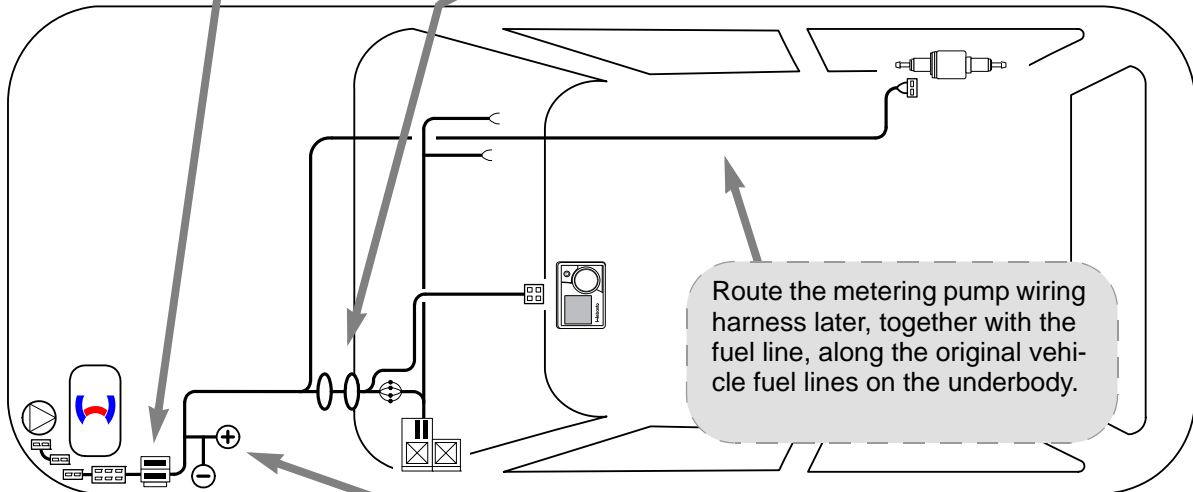
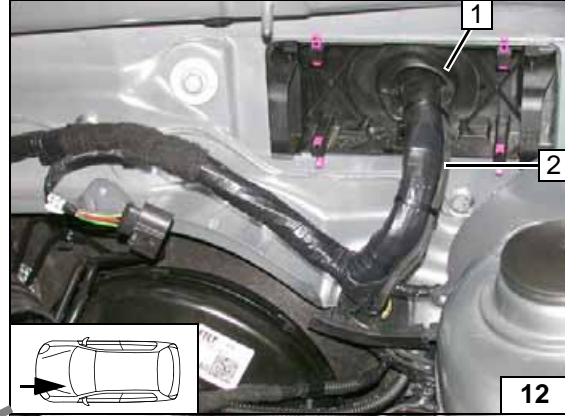
Engine compartment fuse holder

- 1 Tighten M5x16 bolt with flanged nut
- 2 M6x20 bolt, large diameter washer, original vehicle hole, flanged nut

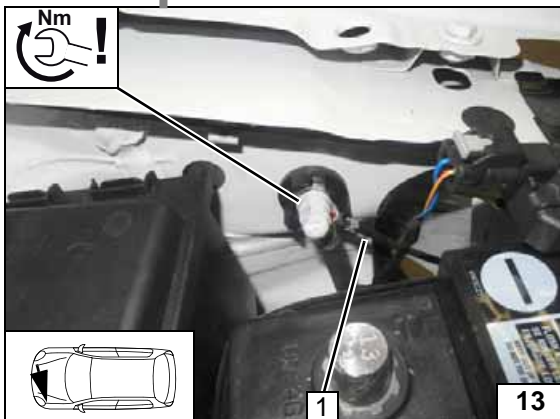


Passenger compartment wiring harness pass through

- 1 Protective rubber plug of coolant reservoir pass through
- 2 Wiring harnesses of heater, heater control

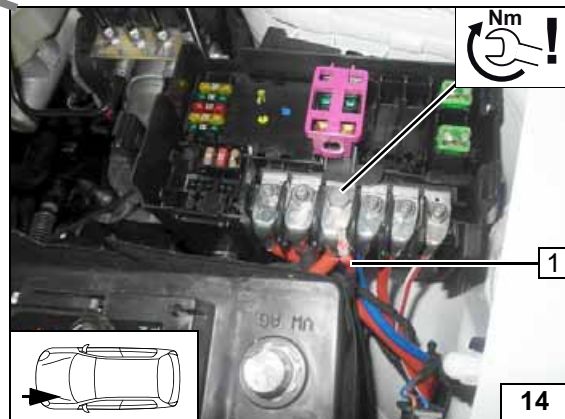


Wiring harness routing diagram



Earth wire

- 1 Earth wire on original vehicle earth support point



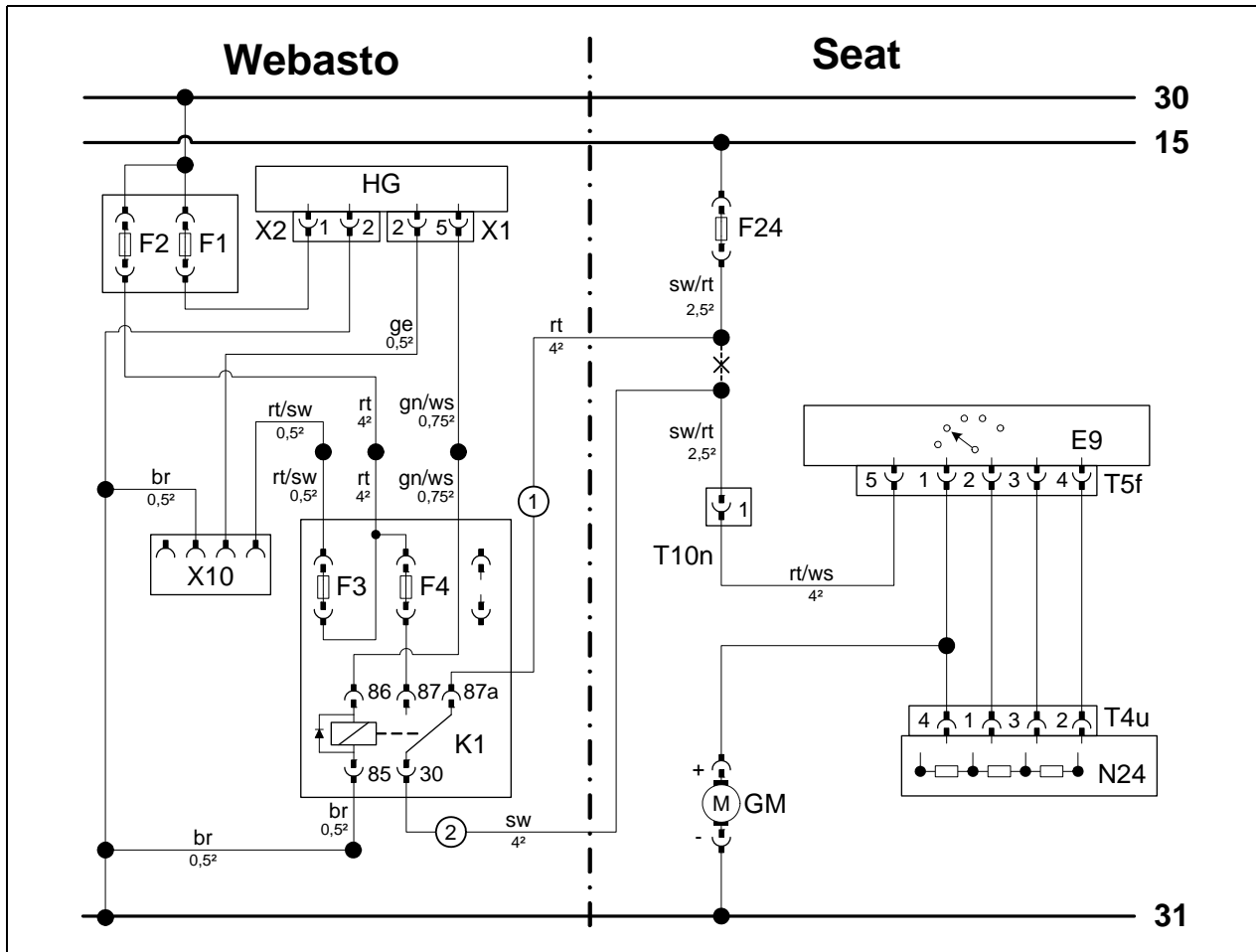
Positive wire

- 1 Positive wire on positive distributor





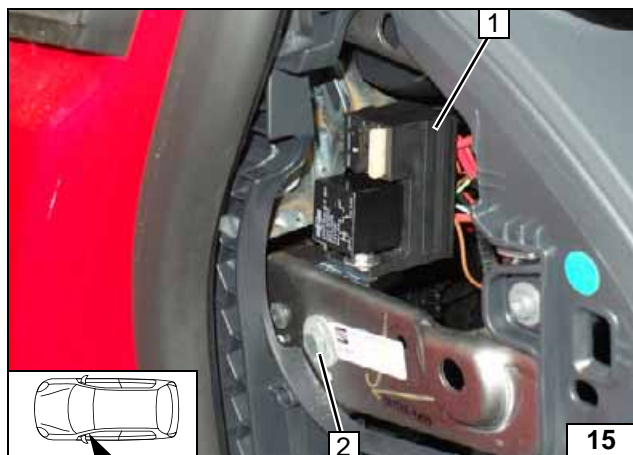
Manual Air-Conditioning Fan Controller



Wiring diagram

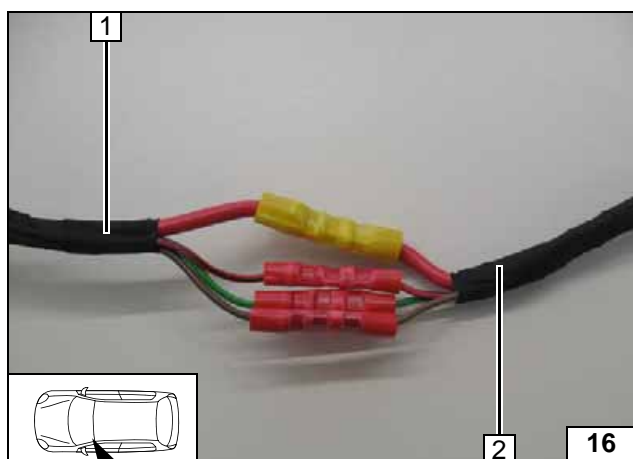
Webasto components		Vehicle components		Colours and symbols	
HG	TT-Evo heater	F24	30A fuse	rt	red
X1	6-pin heater connector	E9	Switch unit	ws	white
X2	2-pin heater connector	T5f	5-pin connector E9	sw	black
F1	20A fuse	T10n	10-pin connector	br	brown
F2	30A fuse	N24	Resistor group	gn	green
X10	4-pin connector of heater control	T4u	4-pin connector N24	ge	yellow
F3	1A fuse	GM	Fan motor		
F4	25A fuse			X	Cutting point
K1	Fan relay			Wiring colours may vary.	

Legend



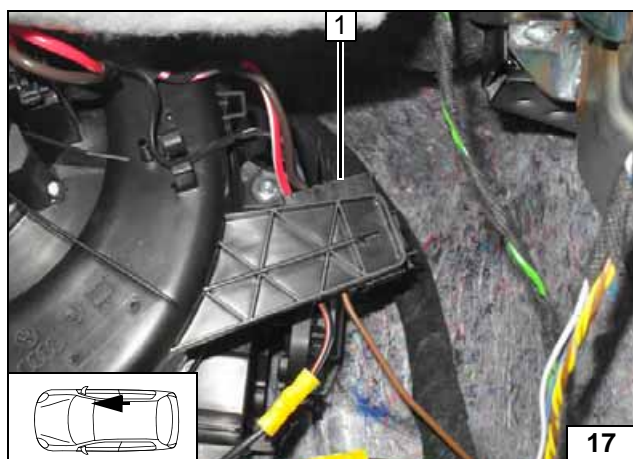
- 1 Passenger compartment relay and fuse holder
- 2 M6x20 bolt, large diameter washer [2x], original vehicle hole, flanged nut

Installing passenger compartment relay and fuse holder



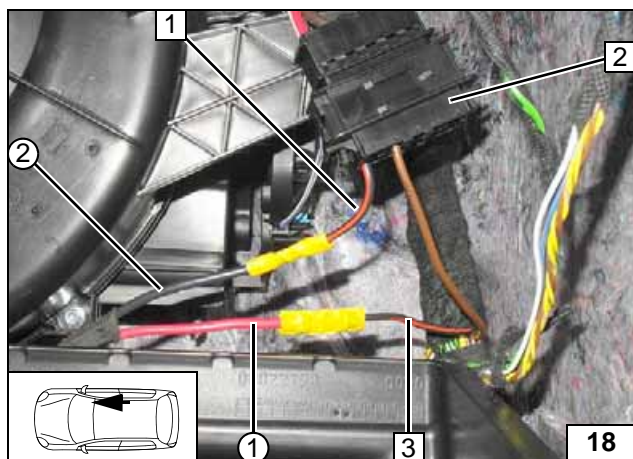
- 1 Passenger compartment relay and fuse holder wiring harness
- 2 Heater wiring harness

Connecting same colour wires of wiring harnesses



- 1 Detach connector T10n

Attaching connector T10n

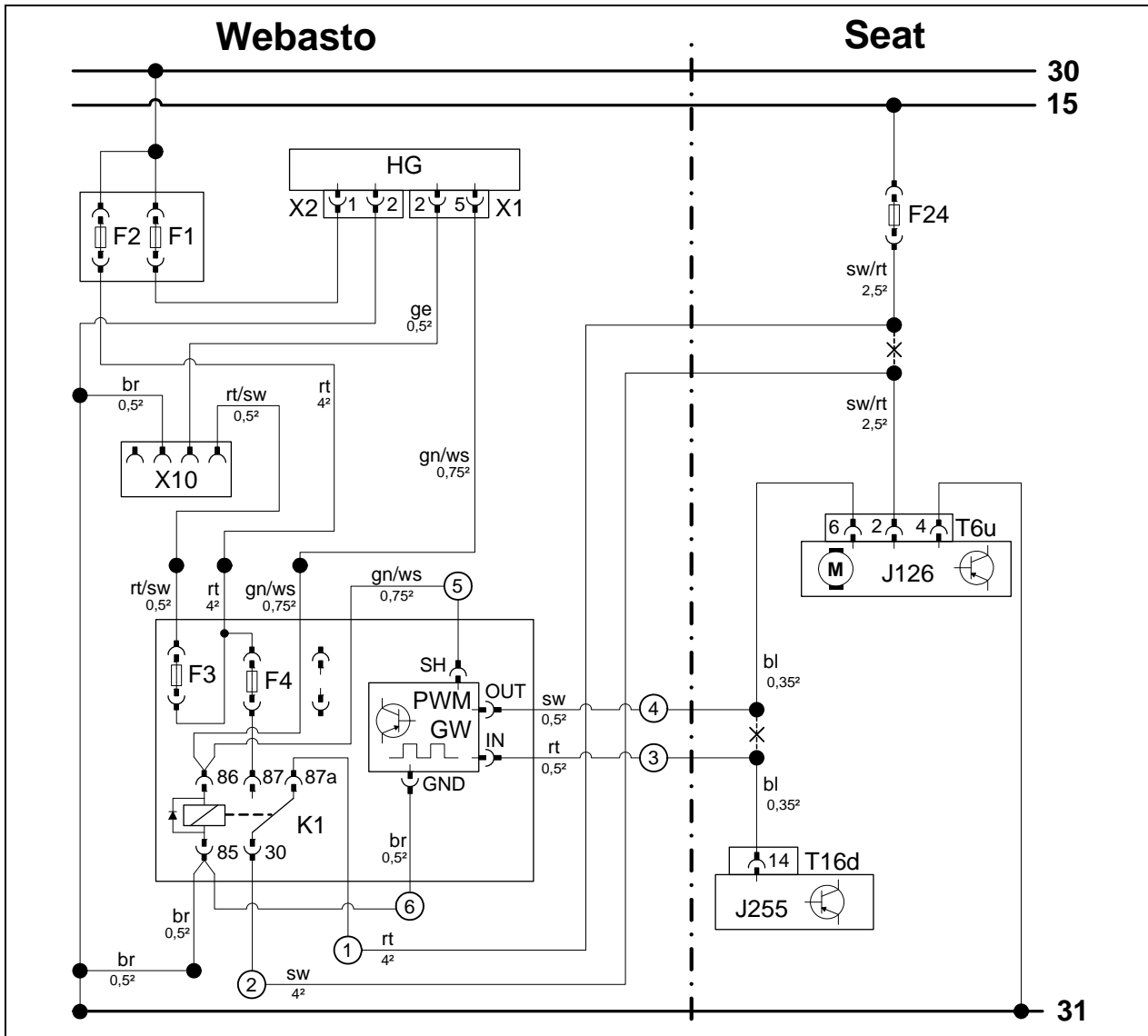


- 1 Black/red (sw/rt) wire from connector T10n / pin 1
- 2 10-pin connector T10n
- 3 Black/red (sw/rt) wire of fuse F24
- ① Red (rt) wire of K1/87a, fan wiring harness
- ② Black (sw) wire of K1/30, fan wiring harness

Attaching connector T10n



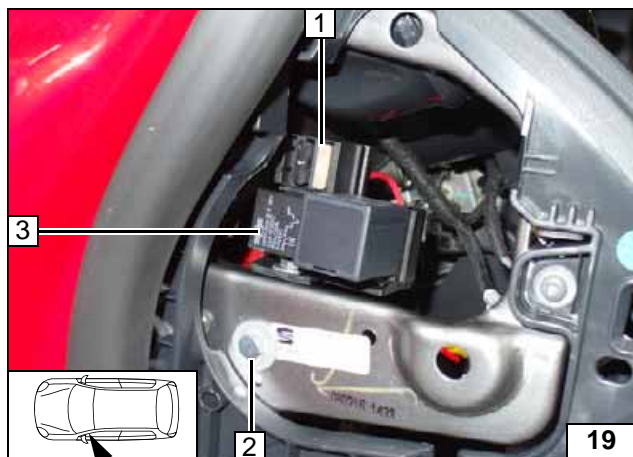
Automatic Air-Conditioning Fan Controller



Wiring diagram

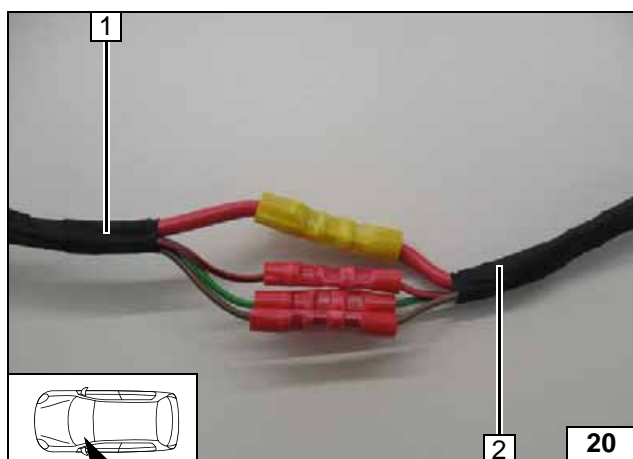
Webasto components		Vehicle components		Colours and symbols	
HG	TT-Evo heater	F24	30A fuse	rt	red
X1	6-pin heater connector	J126	Fan unit	ws	white
X2	2-pin heater connector	T6u	6-pin connector J126	sw	black
F1	20A fuse	J255	Air-conditioning control unit	br	brown
F2	30A fuse	T16d	16-pin connector J255	gn	green
X10	4-pin connector of heater control			ge	yellow
F3	1A fuse				
F4	25A fuse				
PWM GW	Pulse width modulator				
K1	Fan relay				
PWM GW settings:					
Duty cycle: 100% (DC)					
Frequency: not relevant					
Voltage: 3.3V					
Function: High side					
				X	Cutting point
Wiring colours may vary.					

Legend



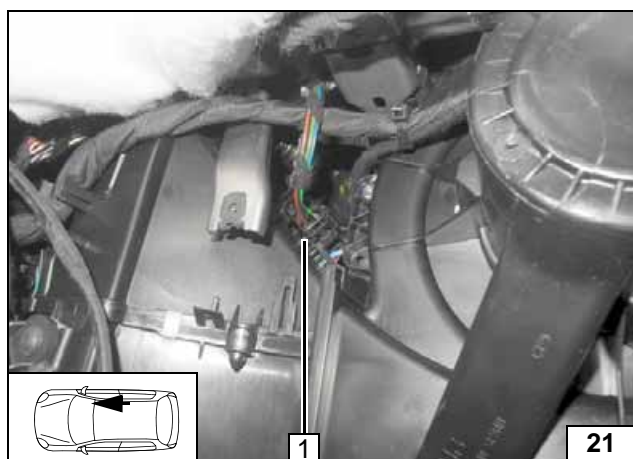
- 1 25A fuse F4
- 2 M6x20 bolt, large diameter washer, original vehicle hole, flanged nut
- 3 Relay K1

Installing passenger compartment relay and fuse holder



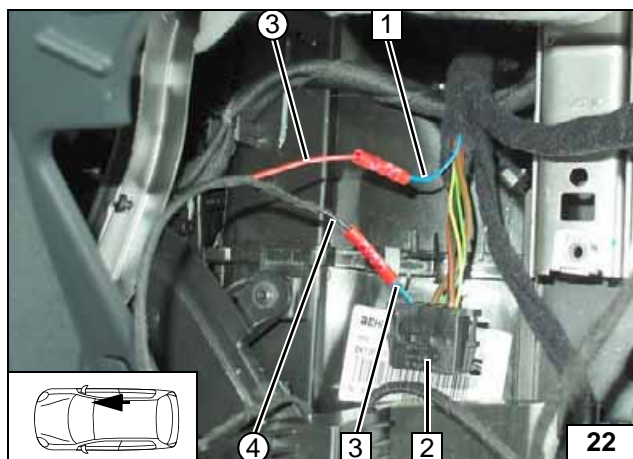
- 1 Passenger compartment relay and fuse holder wiring harness
- 2 Heater wiring harness

Connecting same colour wires of wiring harnesses



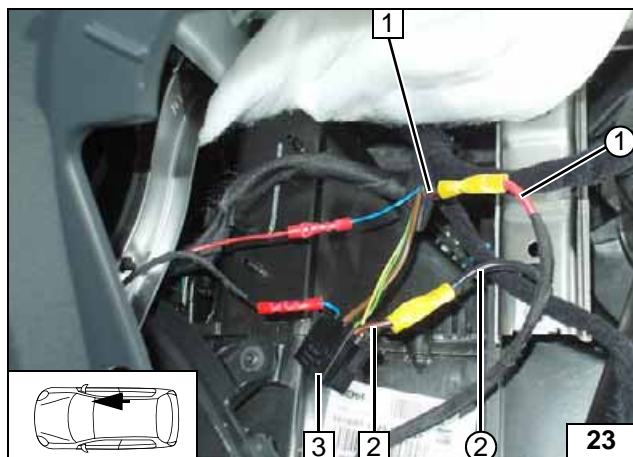
- 1 Pull off 6-pin connector T6u

Connecting fan unit



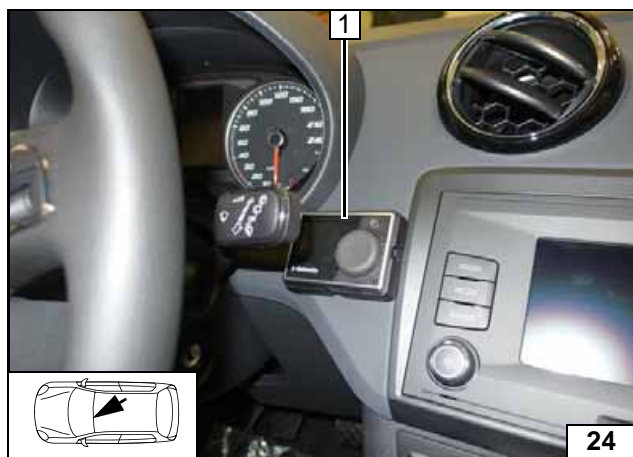
- 1 Blue (bl) wire of connector T16d / pin 14
- 2 6-pin connector T6u
- 3 Blue (bl) wire of connector T6u / pin 6
- ③ Red (rt) wire from PWM GW / IN of wiring harness of PWM control
- ④ Black (sw) wire from PWM GW / OUT of wiring harness of PWM control

Connecting fan unit



- 1 Black/red (sw/rt) wire of fuse F24
- 2 Black/red (sw/rt) wire of connector T6u / pin 2
- 3 6-pin connector T6u
- ① Red (rt) wire of K1/87a, fan wiring harness
- ② Black (sw) wire of K1/30, fan wiring harness

**Connect-
ing fan unit**

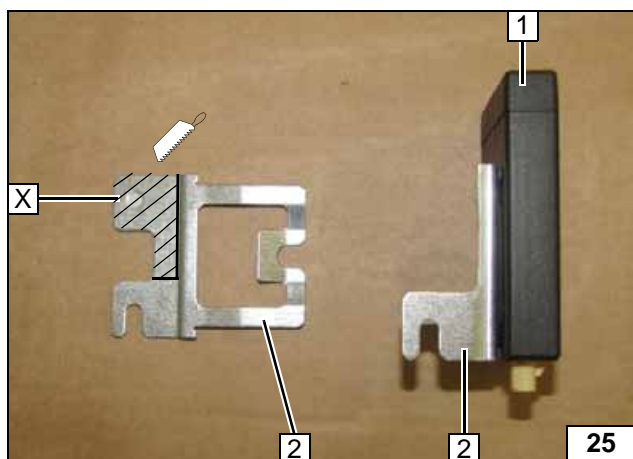


MultiControl CAR Option

- 1 MultiControl CAR with frame

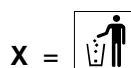


**Installing
MultiControl
CAR**

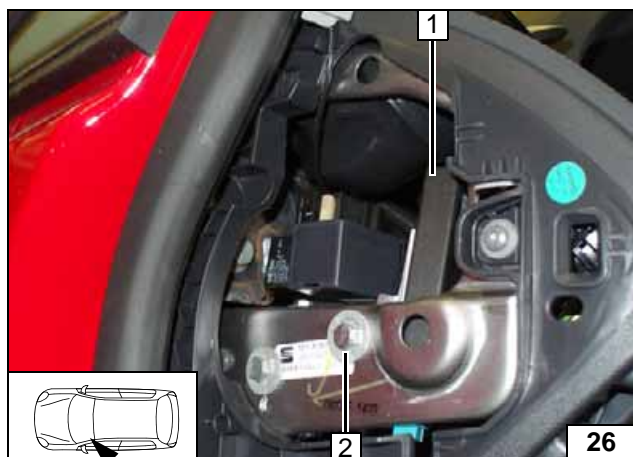


Remote Option (Telestart)

Adapt bracket 2 as shown, install on receiver 1.



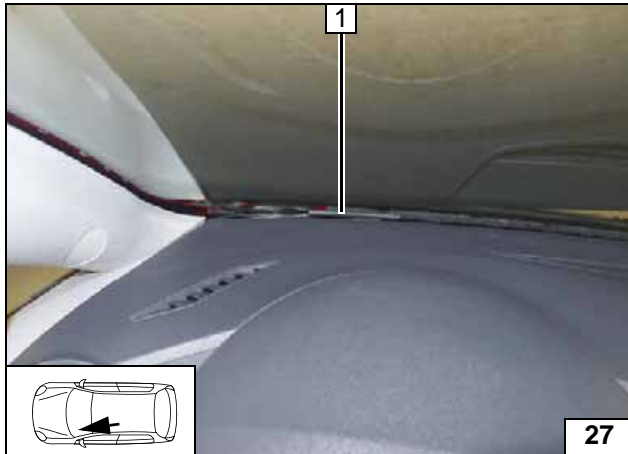
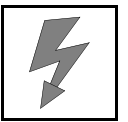
**Premount-
ing receiver**



- 1 Receiver
- 2 M6x20 bolt, large diameter washer, original vehicle hole, flanged nut

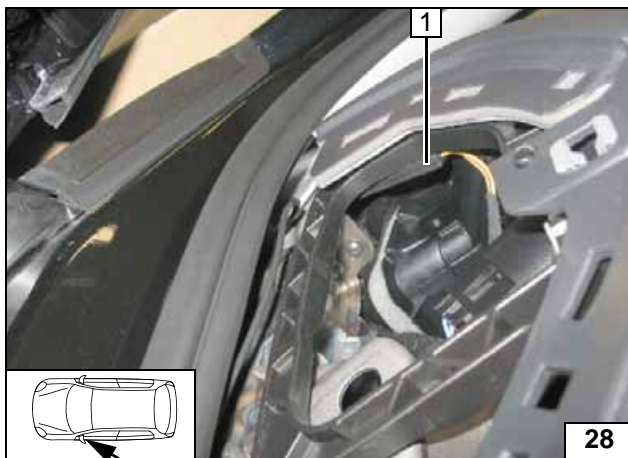


**Installing
receiver**



1 Aerial

Installing aerial

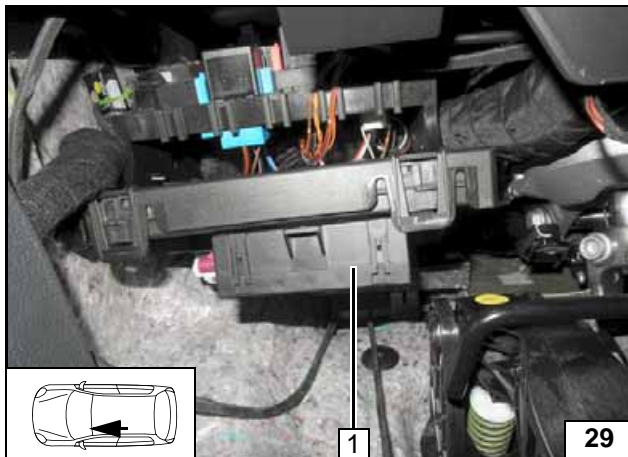


Temperature sensor T100 HTM

Fasten temperature sensor 1 with double-sided adhesive tape.



Installing temperature sensor

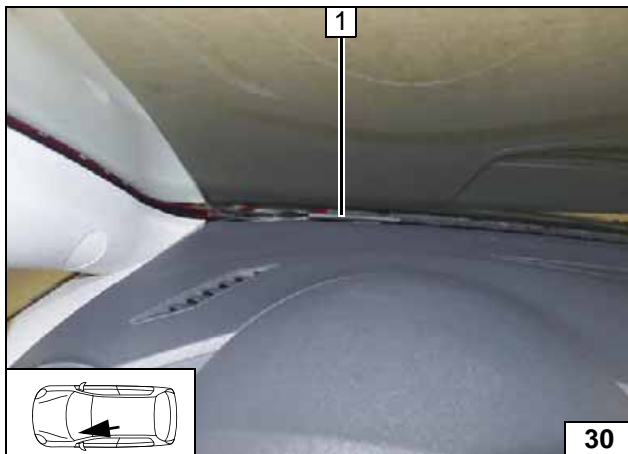


ThermoCall Option

Fasten receiver 1 with double-sided adhesive tape.

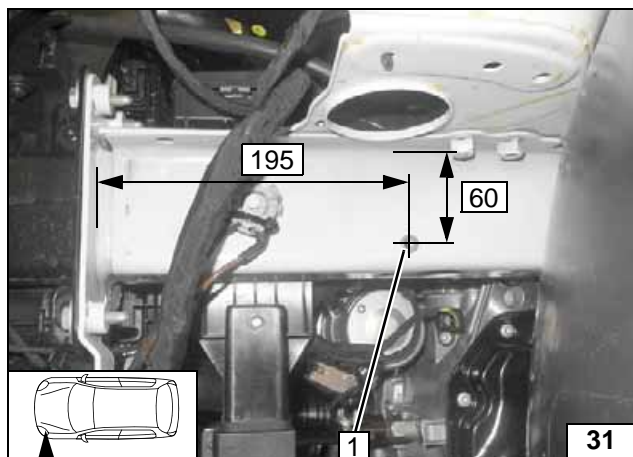
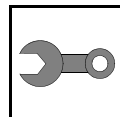


Installing receiver



1 Aerial (optional)

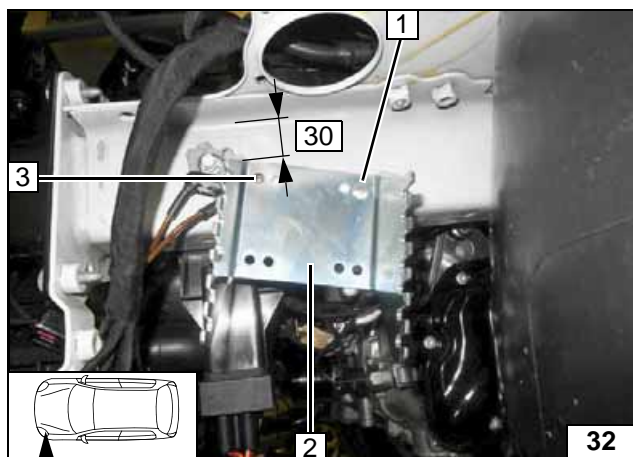
Installing aerial



Preparing Installation Location

- 1 9.1 mm dia. hole; M6 rivet nut

Installing rivet nut

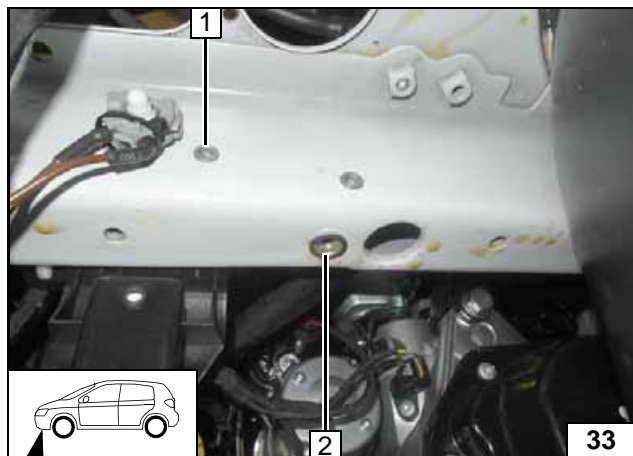


Loosely install bracket 2 and align as shown.

- 1 M6x20 bolt
- 3 Copy hole pattern



Copying hole pattern

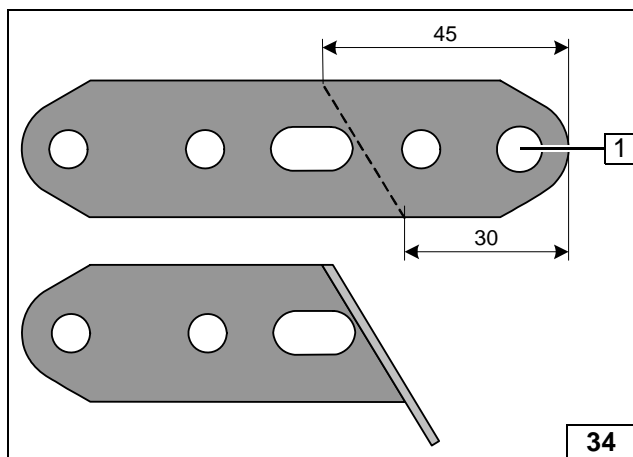


Remove bracket.

- 1 9.1 mm dia. hole; M6 rivet nut
- 2 Original vehicle hole, M10 rivet nut

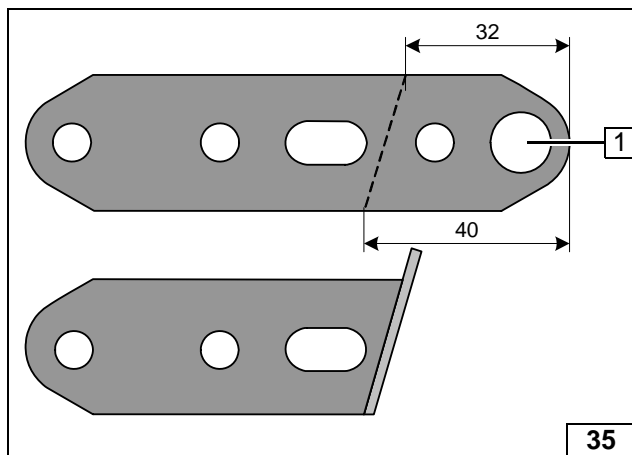


Installing rivet nuts



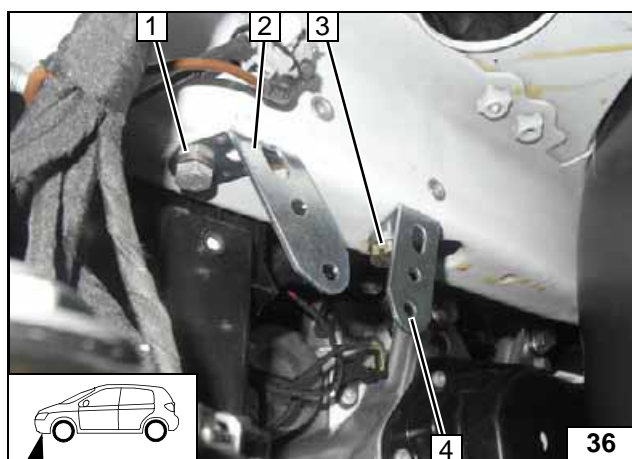
- 1 Drill out hole to 8.5 mm dia.

Angling down perforated bracket A



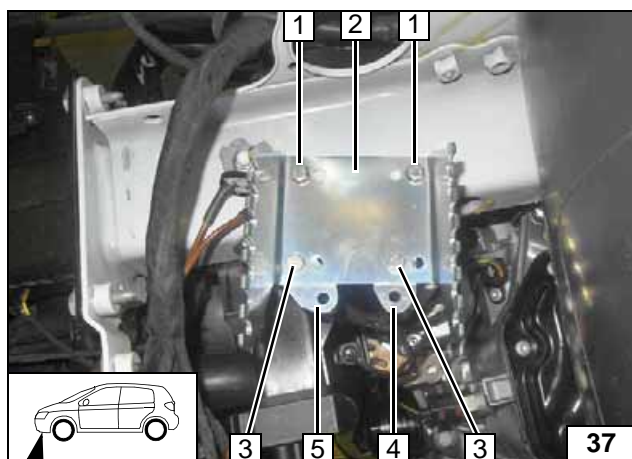
1 Drill out hole to 10.5 mm dia.

Angling down perforated bracket B



- 1 M8x20 bolt, spring lockwasher, existing threaded hole
- 2 Perforated bracket A
- 3 M10x16 bolt, spring lockwasher
- 4 Perforated bracket B

Loosely installing perforated brackets

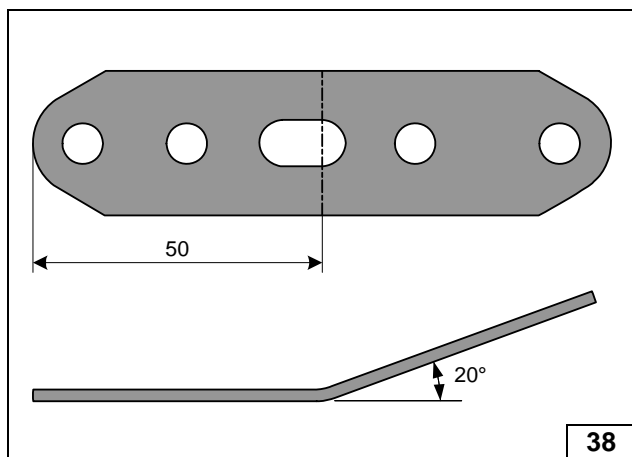


Tighten loose screw connections.

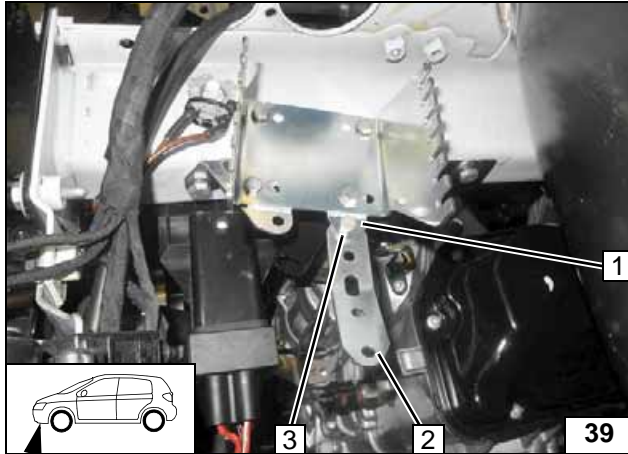
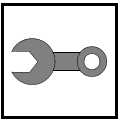
- 1 M6x20 bolt, spring lockwasher [2x each]
- 2 Bracket
- 3 M6x12 bolt, flanged nut [2x each]
- 4 Perforated bracket B
- 5 Perforated bracket A



Installing bracket

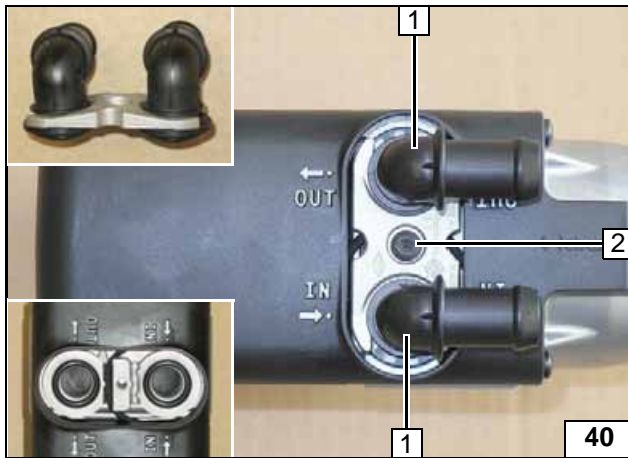


Preparing perforated bracket C



- 1 Perforated bracket **B**
- 2 Perforated bracket **C**
- 3 M6x12 bolt, flanged nut

Installing perforated bracket **C**

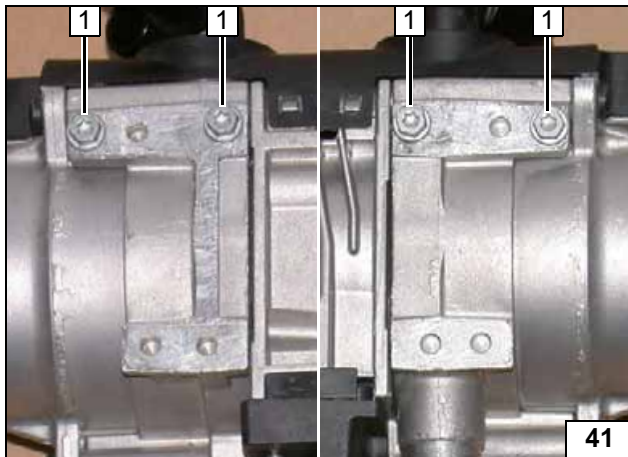


Preparing Heater

- 1 Water connection piece, sealing ring [2x each]
- 2 5x15 self-tapping bolt, retaining plate of water connection piece



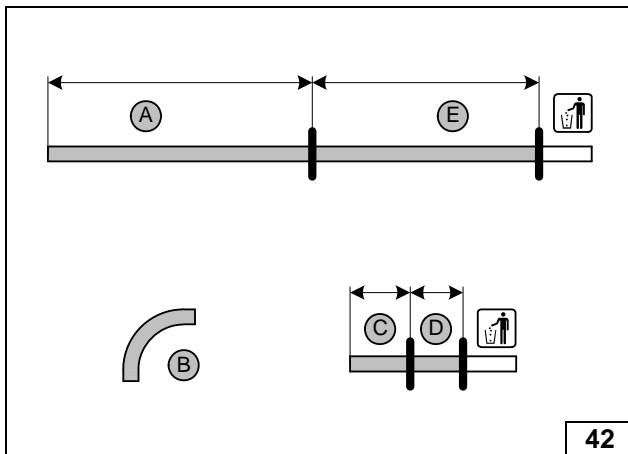
Installing water connection piece



Screw 5x13 self-tapping bolts **1** [4x] into existing holes by a maximum of 3 thread turns.



Premounting bolts loosely

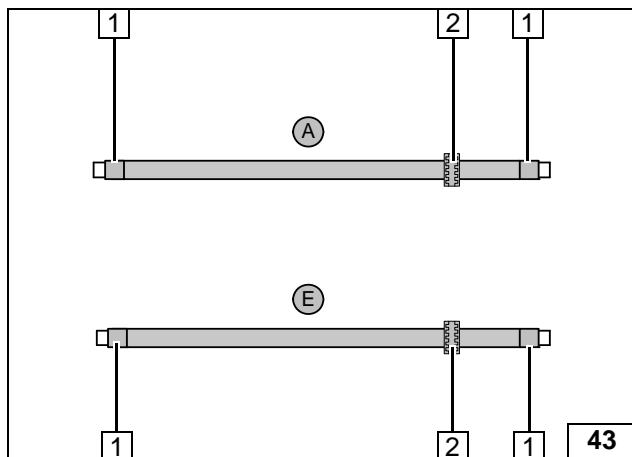


Hose **A**, **E** = 15 mm dia.
 Hose **C**, **D** = 18 mm dia.
 Hose **B** = 90°, 18 mm dia. moulded hose



Cutting hoses to length

	1.0 MPI	1.2 TSI	1.4 TDI
A =	950	900	860
C =	60	60	60
D =	85	85	85
E =	950	930	930

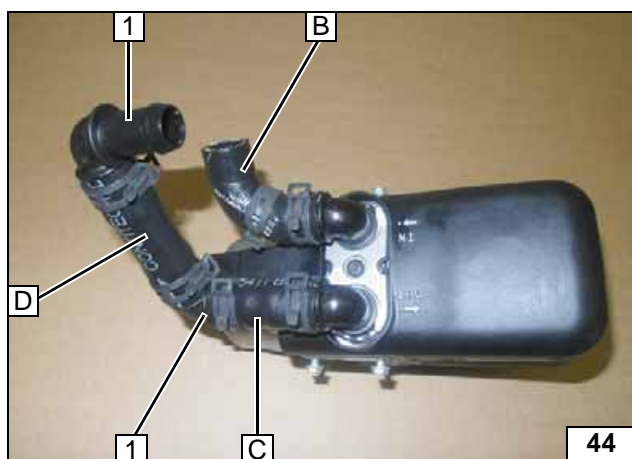


Slide on braided protection hoses and cut to length.



- 1 Cut heat shrink plastic tubing to size, 50mm long [4x]
- 2 Black (sw) rubber isolator [2x]

Installing braided protection hoses

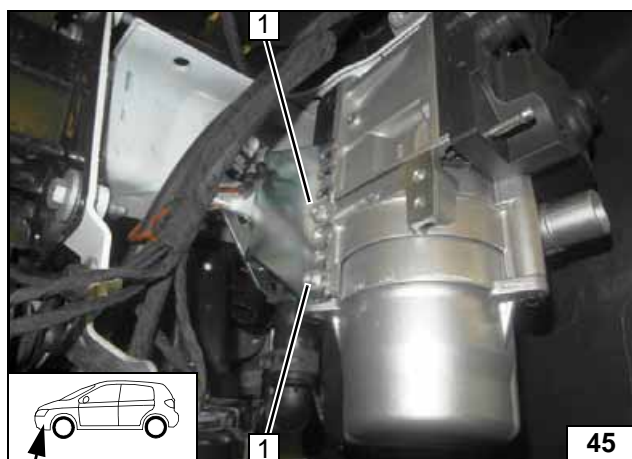


All spring clips = 25 mm dia.



- 1 90°, 18x18mm dia. connecting pipe [2x]

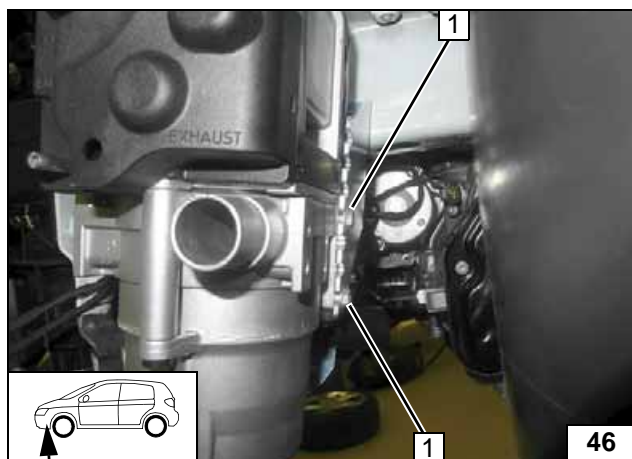
Premounting hoses



Installing Heater

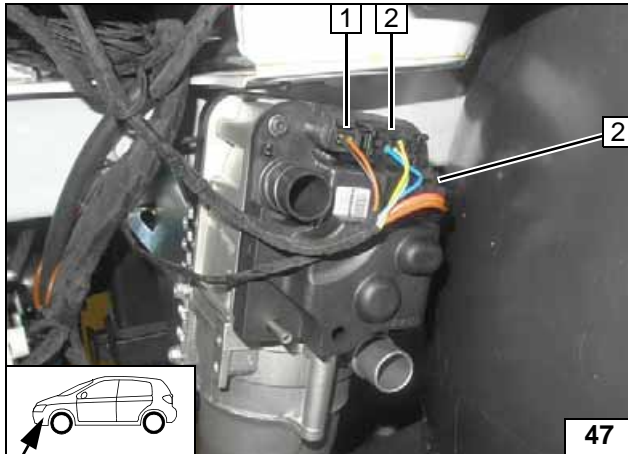
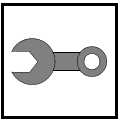
- 1 Tighten 5x13 self-tapping bolt [2x]

Installing heater



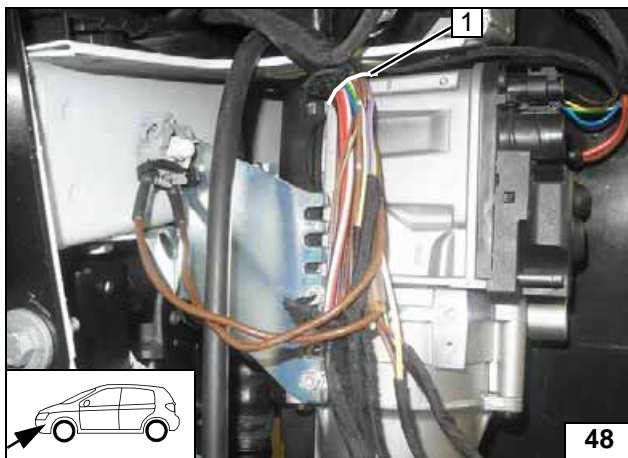
- 1 Tighten 5x13 self-tapping bolt [2x]

Installing heater



- 1 Connector of circulating pump wiring harness
- 2 Heater wiring harness connector [2x]

Installing wiring harnesses



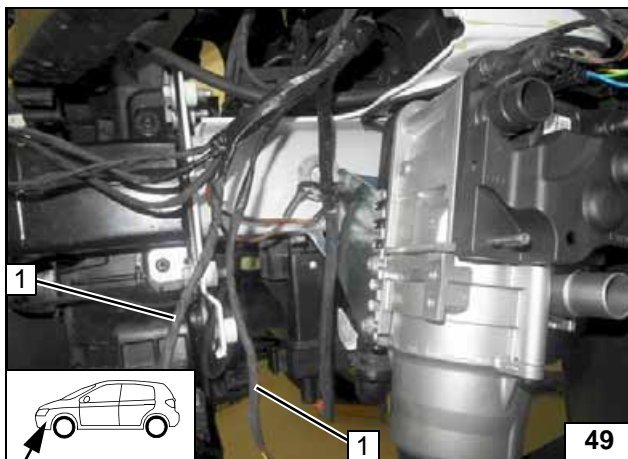
Moving the horn

Vehicles with two horns

Remove insulation of original vehicle wiring harness up to marking 1.



Preparing wiring harness

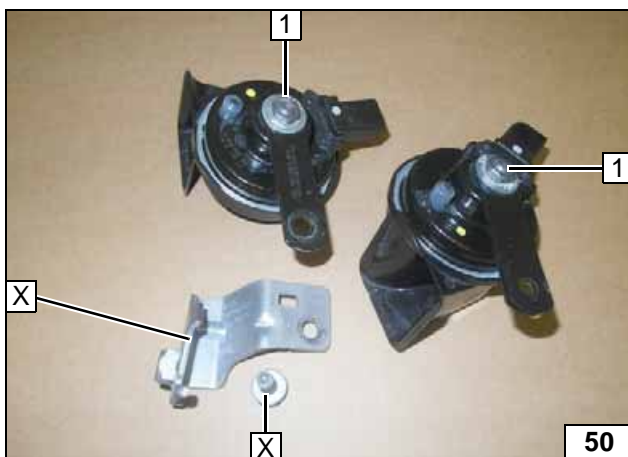


Wrap original vehicle wiring harnesses individually with new insulating tape as shown.

- 1 Wiring harness of horn [2x]



Preparing wiring harnesses

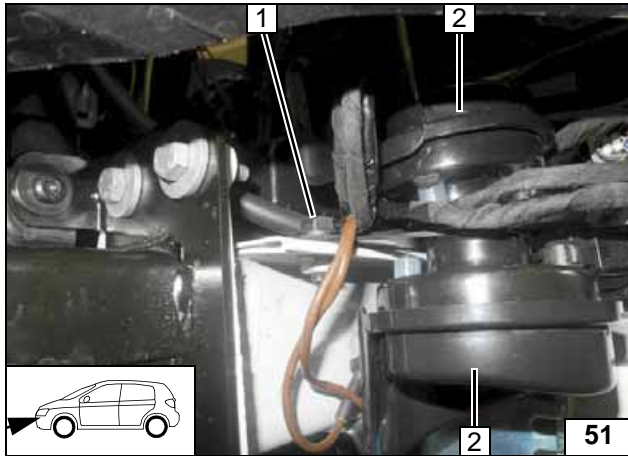
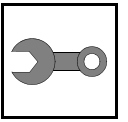


Detach screw fitting at position 1 [2x].

X =



Dismantling horns (1 to 2 pieces)



Loosely mount horn 2 [2x] with bracket.

- 1 Original vehicle bolt, flanged nut



Loosely installing horns

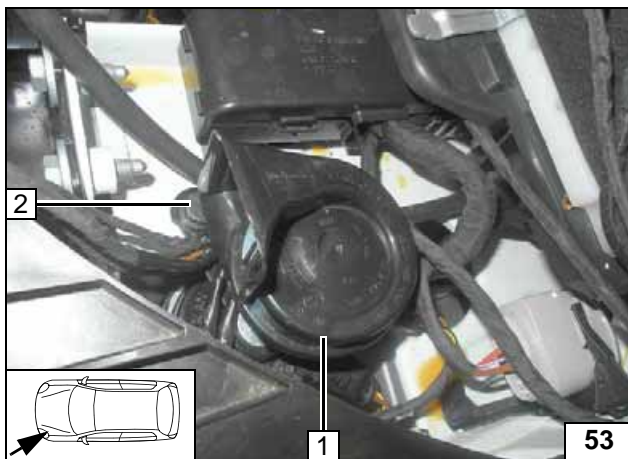


Lower horn 2, identical installation position in case of one horn, align as shown. Ensure sufficient distance from neighbouring components, correct if necessary.

- 1 Install connector of horn wiring harness [2x]



Aligning lower horn

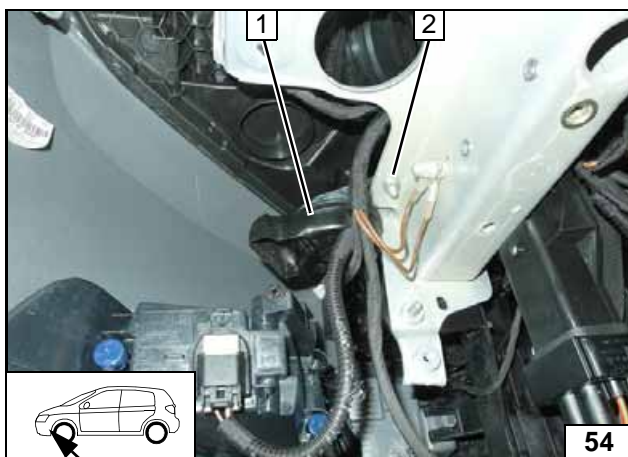


Align upper horn 1 as shown. Ensure sufficient distance from neighbouring components, correct if necessary.

- 2 Tighten original vehicle bolt



Aligning upper horn



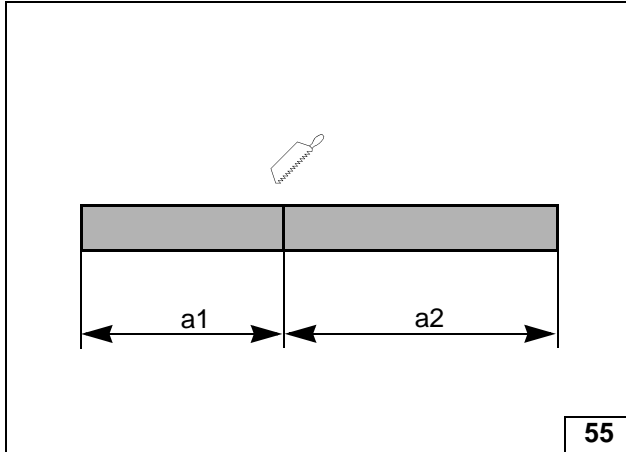
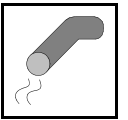
Vehicles with one horn

Install horn 1 with bracket as shown.

- 2 Original vehicle bolt, flanged nut



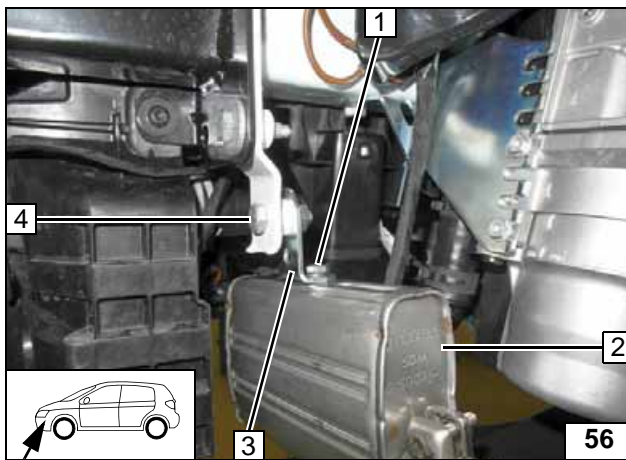
Loosely installing horn



Exhaust Part 1

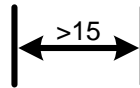
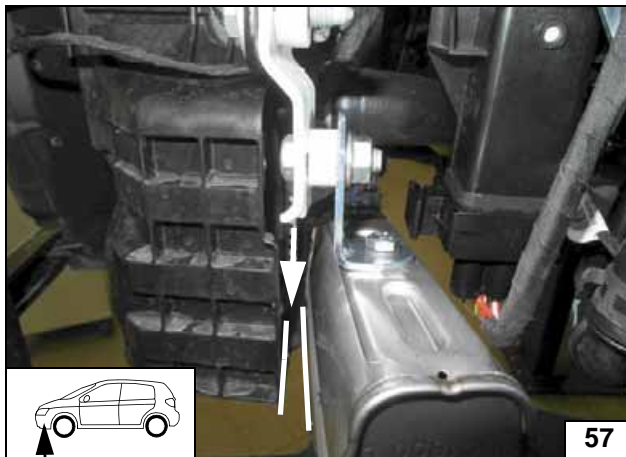
	Petrol	Diesel
a1 =	280	280
a2 =	370	160

Preparing exhaust pipe

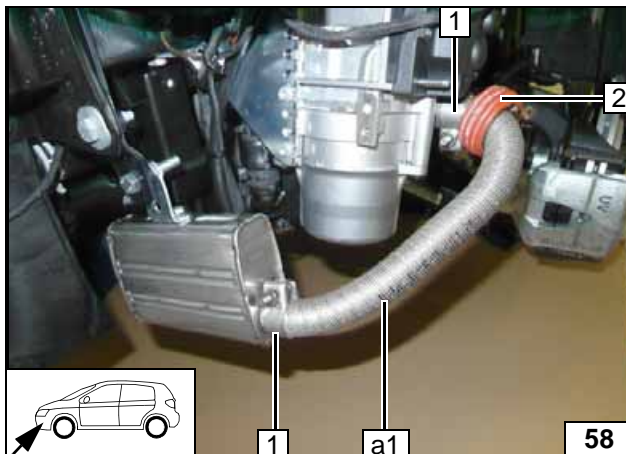


- 1 M6x16 bolt, spring lockwasher
- 2 Silencer
- 3 Angle bracket
- 4 8x30 bolt, flanged nut

Installing silencer

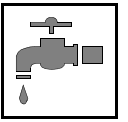


Aligning silencer



- 1 Hose clamp [2x]
- 2 Spacer bracket

Installing exhaust pipe a1

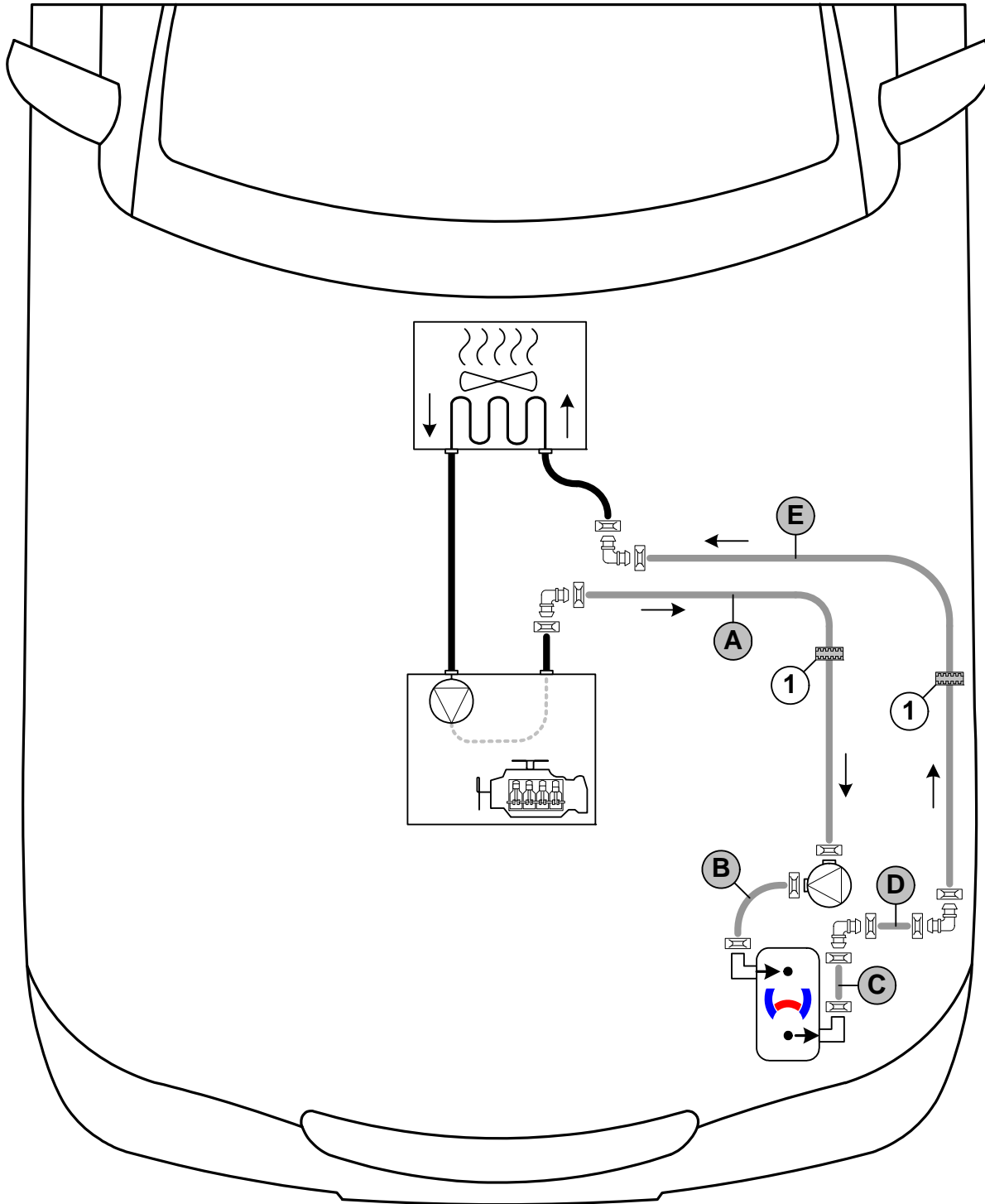


Coolant Circuit






Any coolant running off should be collected in an appropriate container. Route hoses kink-free. Unless specified otherwise, always fasten using cable ties. Position clamps so that other hoses cannot be damaged. The heater must be filled with coolant when installing the hoses.

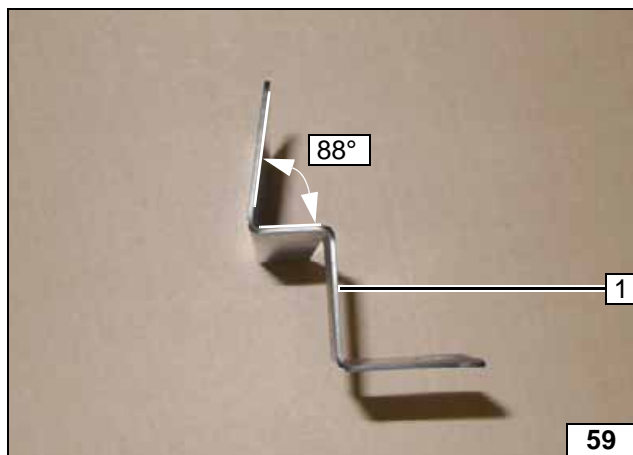
The connection should be modelled on an 'inline' circuit and based on the following diagram:



Hose routing diagram

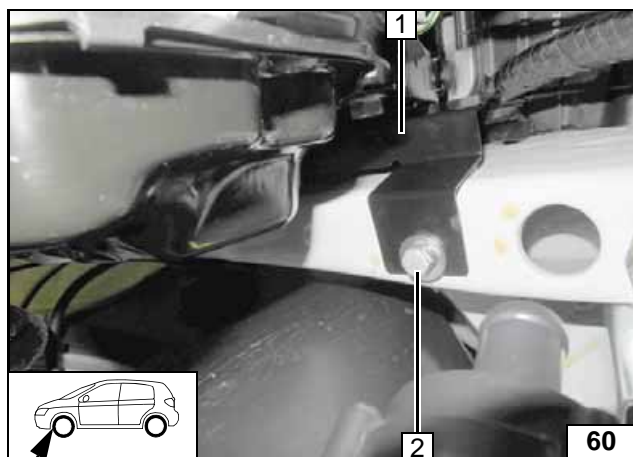
All spring clips without a specific designation  = 25 mm dia. All connecting pipes  = 18x18 mm dia.
 1 = Black (sw) rubber isolator 





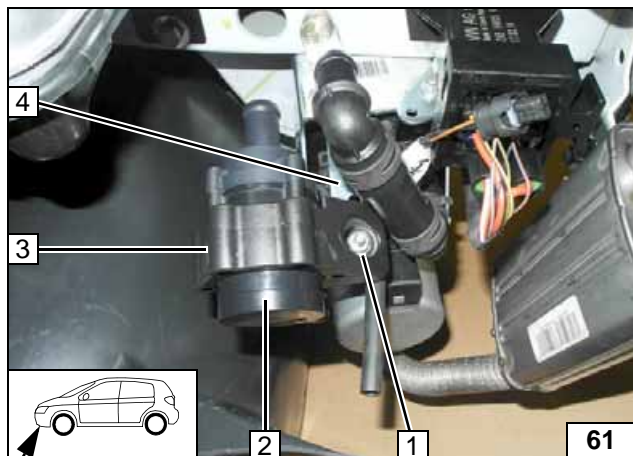
1 Guard plate

Bending guard plate



1 Guard plate
2 M8x20 bolt, spring lockwasher, large diameter washer, existing threaded hole

Installing guard plate

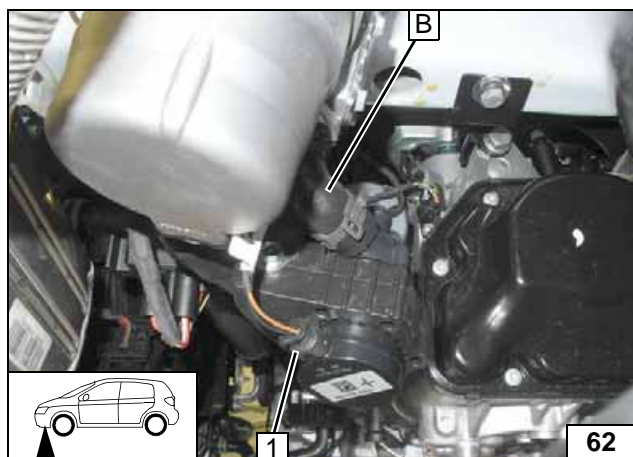


Use lower hole of perforated bracket **C 4**.



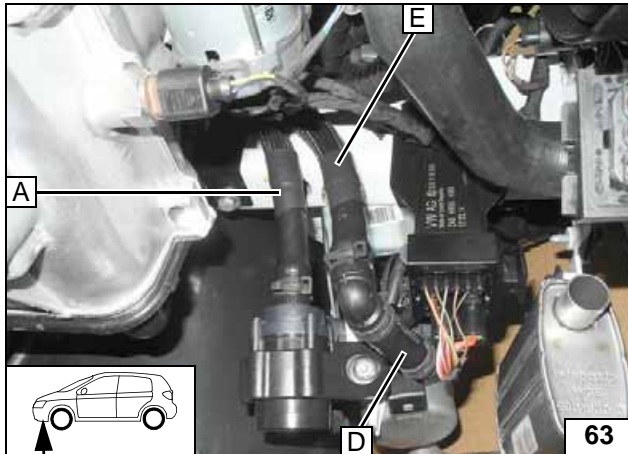
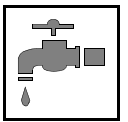
1 M6x25 bolt, flanged nut
2 Circulating pump
3 Circulating pump mount

Installing circulating pump

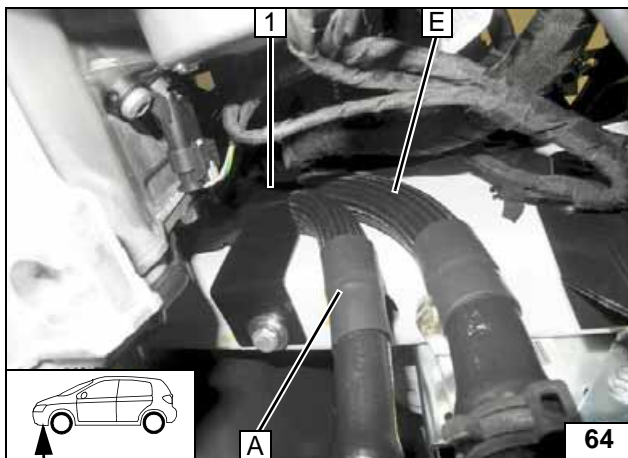


1 Connector of circulating pump wiring harness

Connecting circulating pump



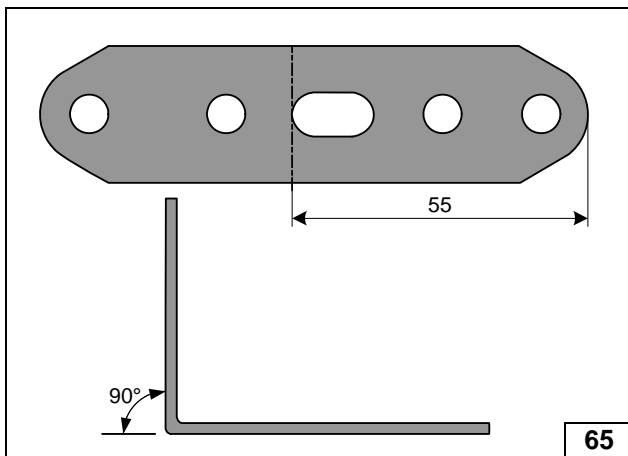
Connect-
ing heater



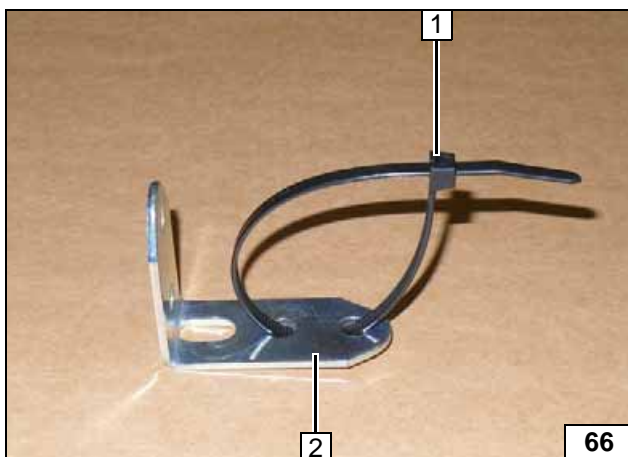
Route hose **A** and **E** on the frame side member behind guard plate 1.



Routing in
engine
compartment

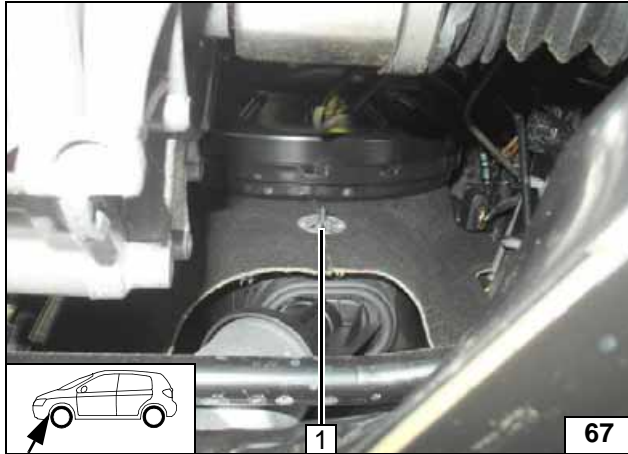


Angling
down perforated bracket



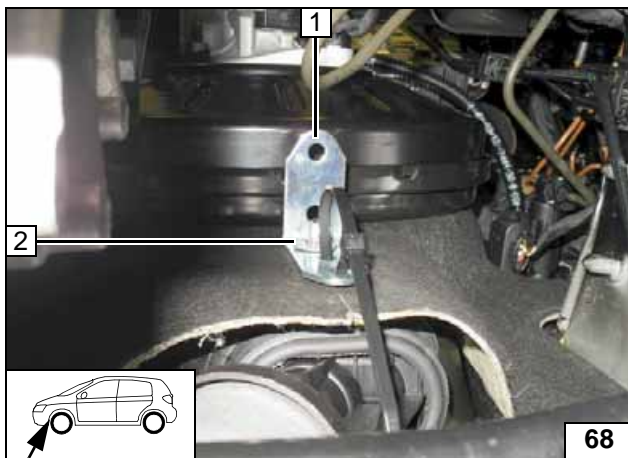
- 1 Cable tie through both holes
- 2 Perforated bracket

Preparing
perforated
bracket



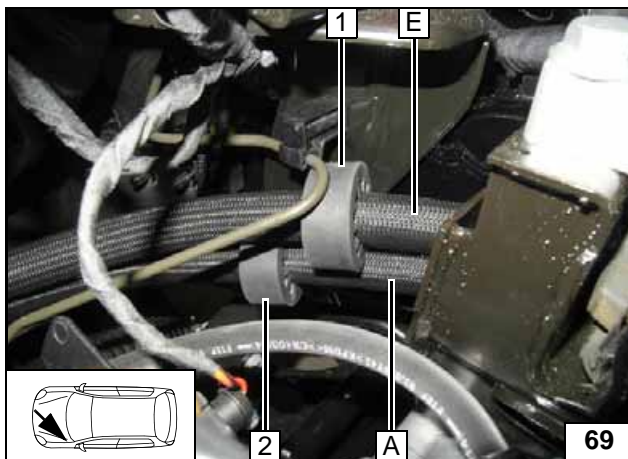
- 1 Discard retaining clamp

Removing retaining clamp



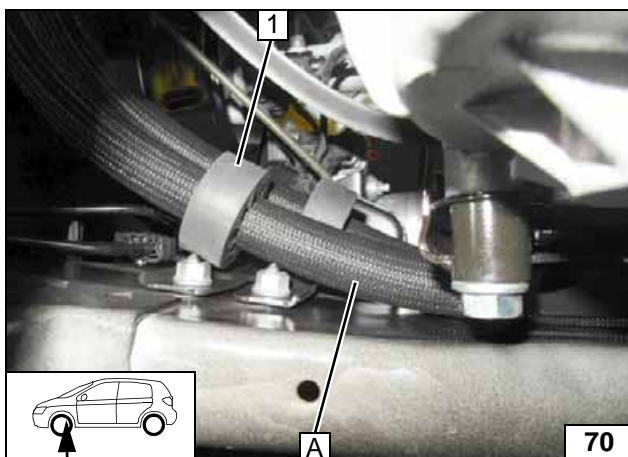
- 1 Perforated bracket
- 2 Plate nut on original vehicle stud bolt

Installing perforated bracket



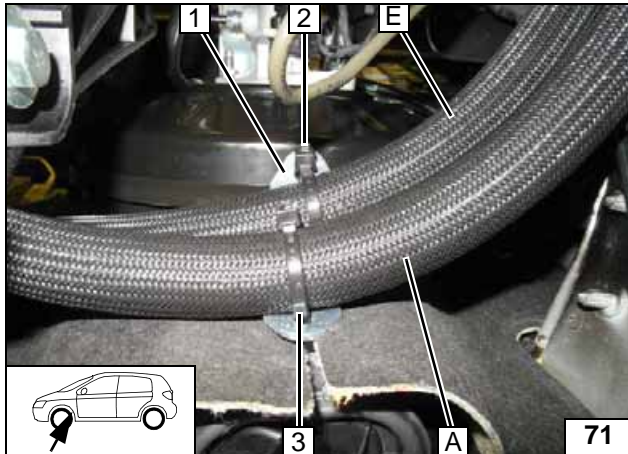
- 1 Align black (sw) rubber isolator with coupling line
- 2 Black (sw) rubber isolator

Routing in engine compartment



- 1 Align black (sw) rubber isolator with original vehicle bolt

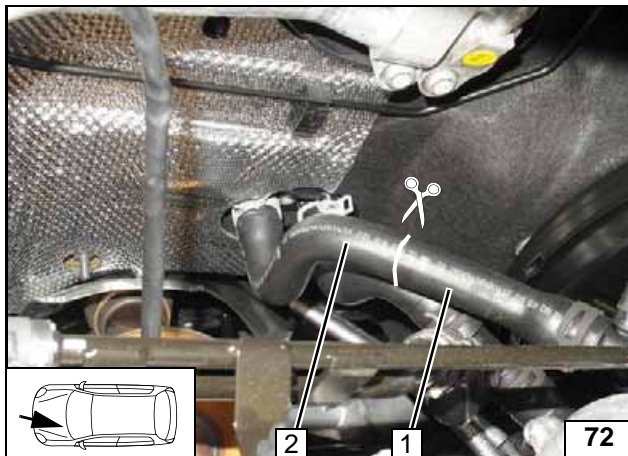
Routing in engine compartment



Insert cable tie **2** through free holes in perforated bracket **1**. Close cable tie **2** and **3**.



Routing in engine compartment



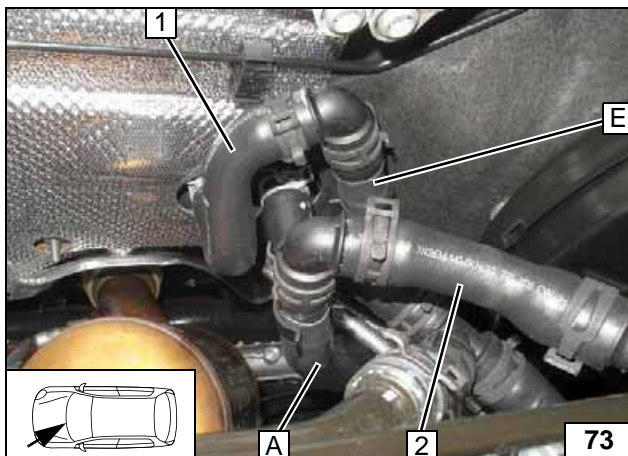
1.0 MPI

Cut off hose of engine outlet / heat exchanger inlet at the marking.

- 1 Engine outlet hose section
- 2 Heat exchanger inlet hose section

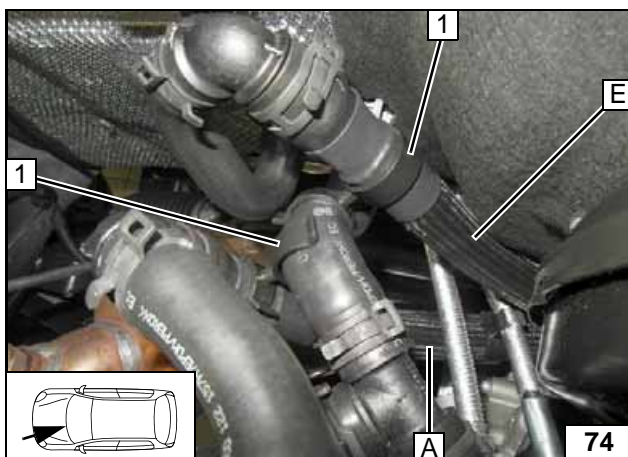


Cutting point



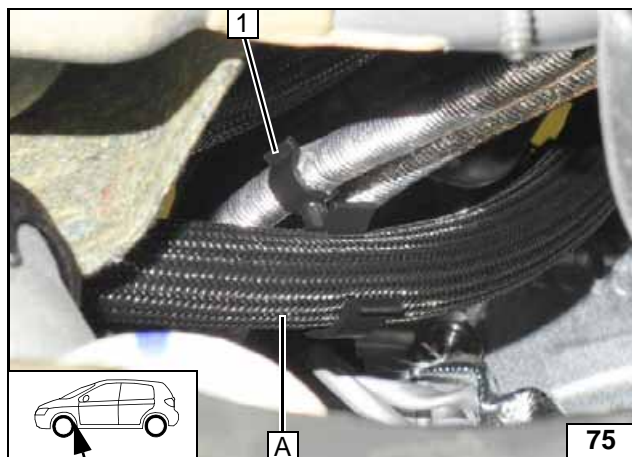
- 1 Heat exchanger inlet hose
- 2 Engine outlet hose

Connecting engine outlet / heat exchanger inlet



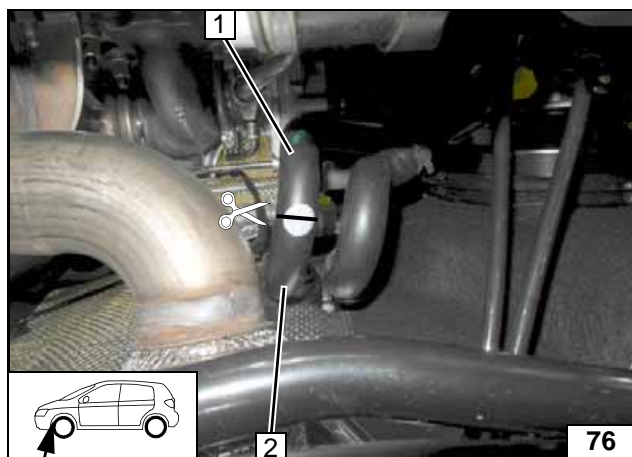
- 1 20x20 hose bracket [2x]

Installing hose bracket



- 1 10x20 hose bracket between gear-shift cable and hose A

Installing hose bracket



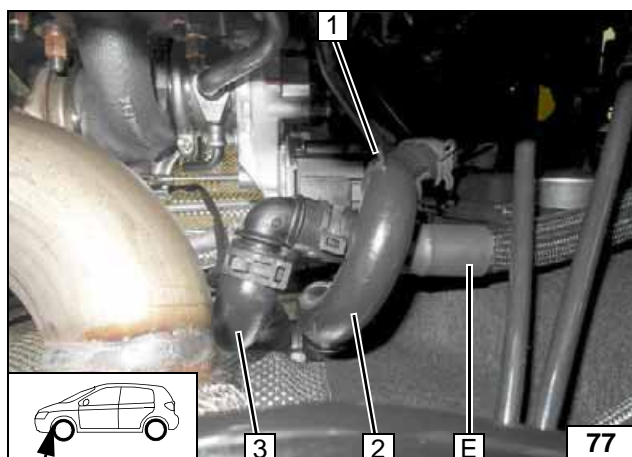
1.2 TSI

Cut off hose of engine outlet / heat exchanger inlet at the marking.

- 1 Engine outlet hose section
- 2 Heat exchanger inlet hose section

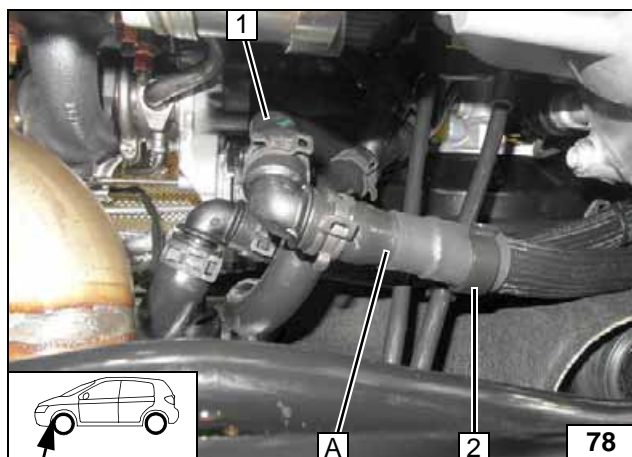


Cutting point



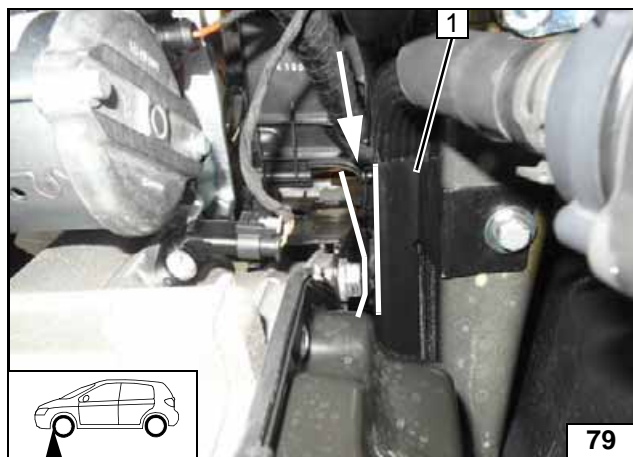
- 1 20x20 hose bracket between hose of heat exchanger outlet 2 and hose E
- 3 Heat exchanger inlet hose section

Connecting heat exchanger inlet



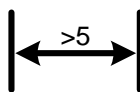
- 1 Engine outlet hose section
- 2 10x20 hose bracket between gear-shift cable and hose A

Connecting engine outlet

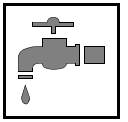


All vehicles

1 Guard plate



Aligning
guard plate

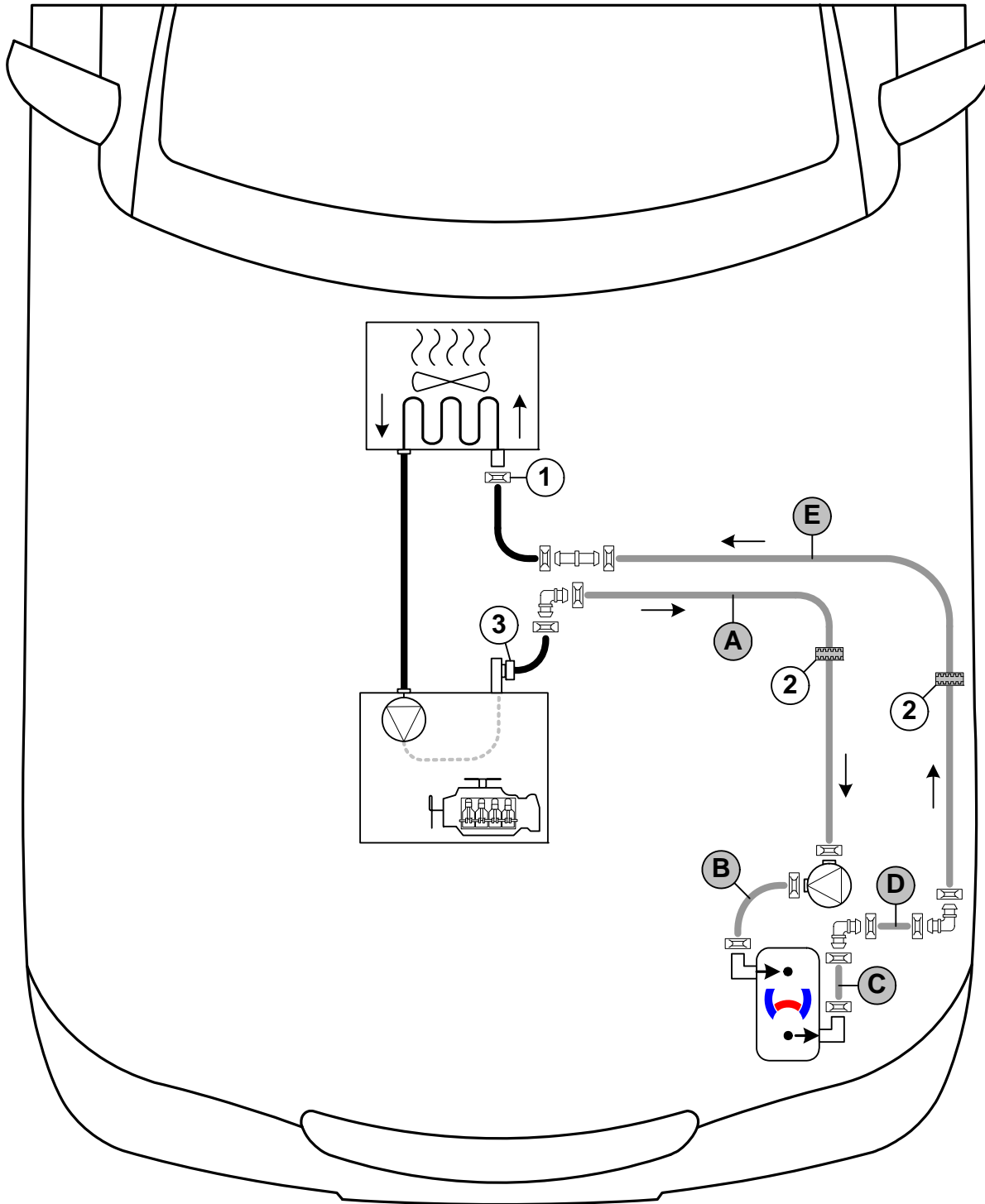


Coolant Circuit for Diesel Vehicles



Any coolant running off should be collected in an appropriate container. Route hoses kink-free. Unless specified otherwise, always fasten using cable ties. Position clamps so that other hoses cannot be damaged. The heater must be filled with coolant when installing the hoses.

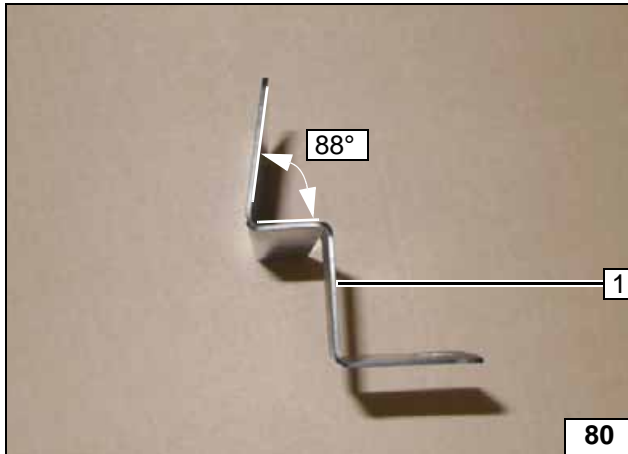
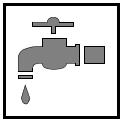
The connection should be modelled on an 'inline' circuit and based on the following diagram:



Hose routing diagram

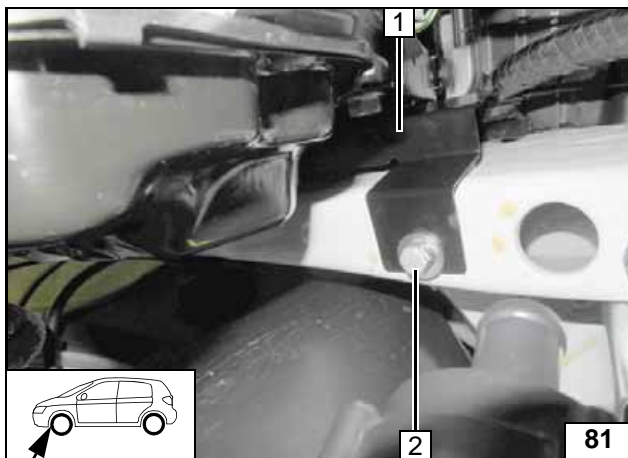
All spring clips without a specific designation = 25 mm dia. **1** = Original vehicle spring clip .
2 = Black (sw) rubber isolator **3** = Coupling piece of engine outlet
 All connecting pipes and = 18x18 mm dia.





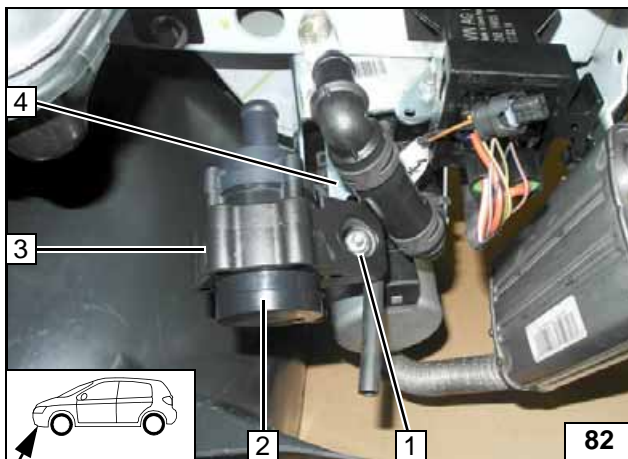
1 Guard plate

Bending guard plate



1 Guard plate
2 M8x20 bolt, spring lockwasher, large diameter washer, existing threaded hole

Installing guard plate

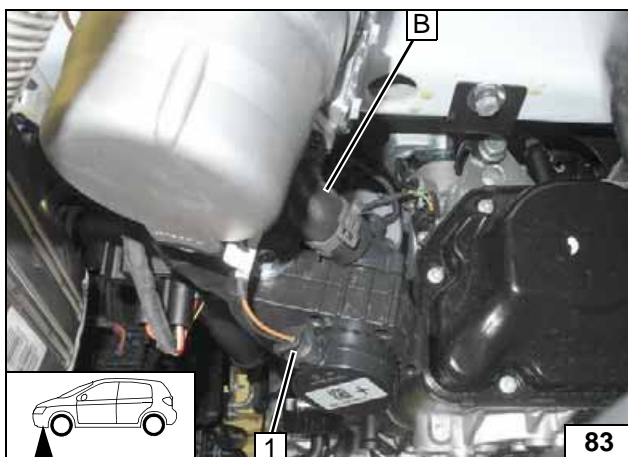


Use lower hole of perforated bracket C 4.



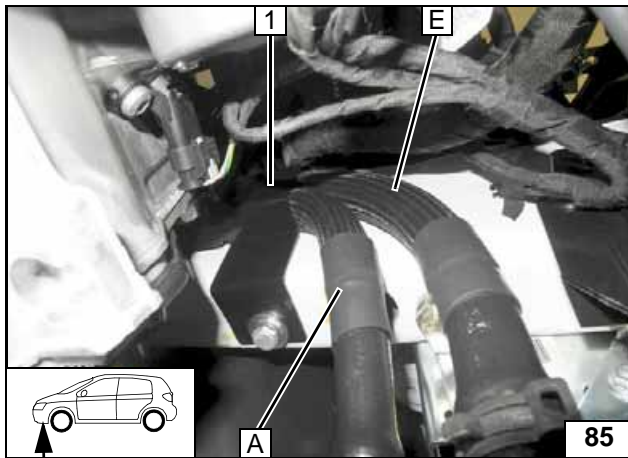
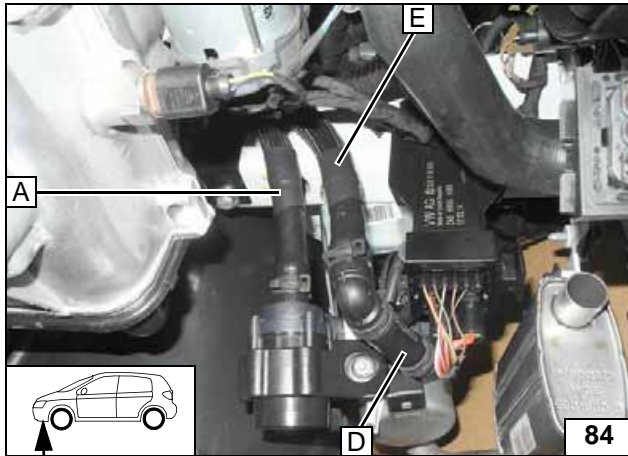
1 M6x25 bolt, flanged nut
2 Circulating pump
3 Circulating pump mount

Installing circulating pump



1 Connector of circulating pump wiring harness

Connecting circulating pump

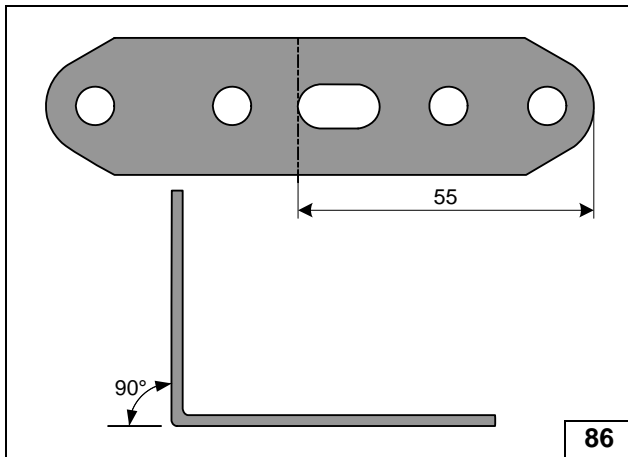


Route hose **A** and **E** on the frame side member behind guard plate 1.

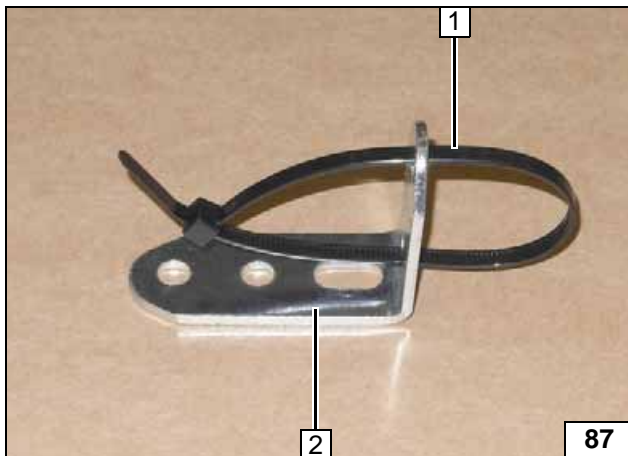


Connect-
ing heater

Routing in
engine
compartment

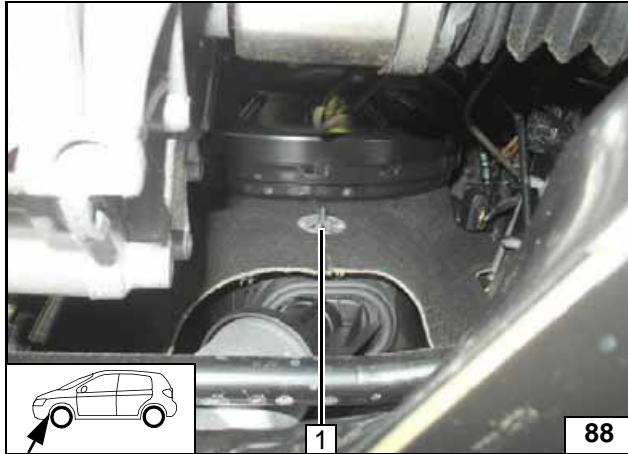
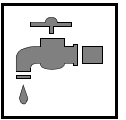


Preparing
perforated
bracket



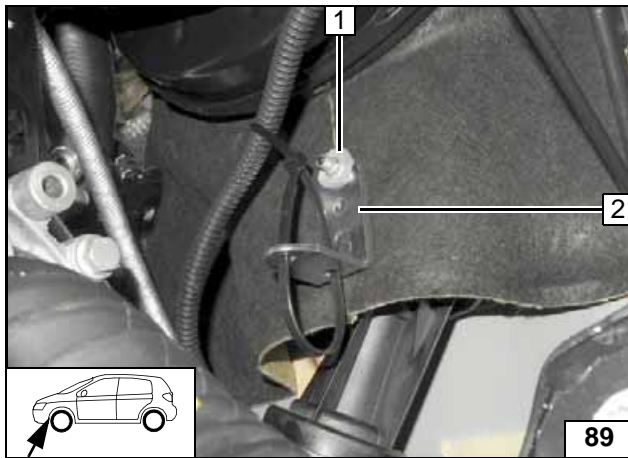
- 1 Cable tie through both holes, do not pull tight
- 2 Perforated bracket

Preparing
perforated
bracket



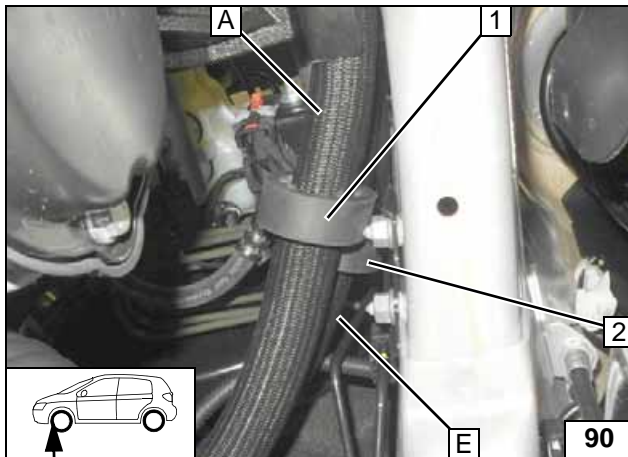
1 Discard retaining clamp

Removing retaining clamp



1 Plate nut on original vehicle stud bolt
2 Perforated bracket

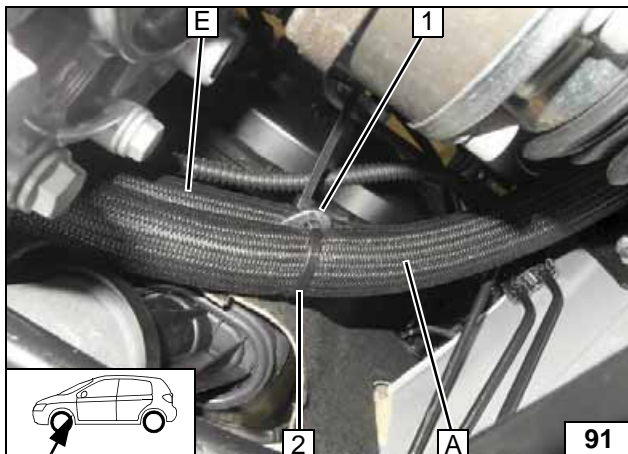
Installing perforated bracket



Slide black (sw) rubber isolator 2 onto hose E and align with coupling line. Slide black (sw) rubber isolator 1 onto hose A and align with original vehicle bolt.



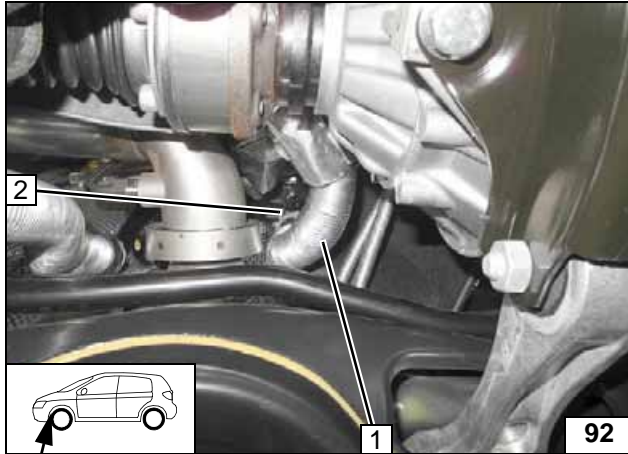
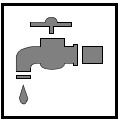
Routing in engine compartment



Route hose E above and hose A under perforated bracket 1 and through cable tie 2. Align hoses, fasten cable tie 2.



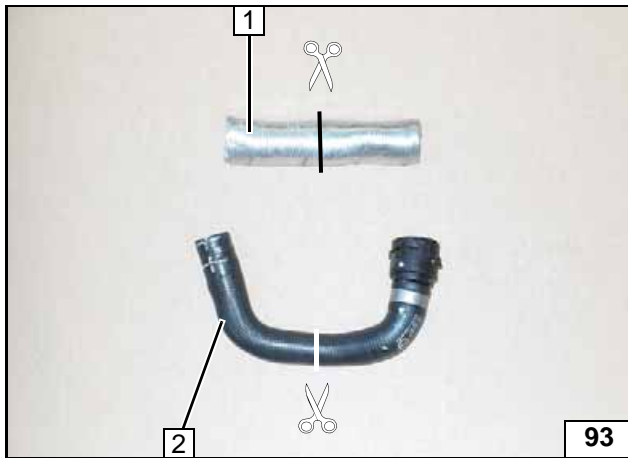
Routing in engine compartment



Remove hose from engine outlet / heat exchanger inlet **1** together with coupling piece of engine outlet. Spring clip **2** will be reused.



Cutting point



Remove heat protection hose **1** and cut at the marking.
Cut off hose on engine outlet/heat exchanger inlet **2** at the markings.

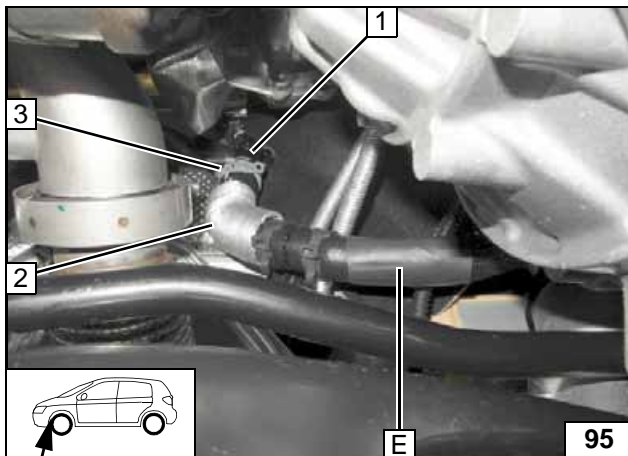


Cutting point



- 1 Hose section of engine outlet with heat protection hose
- 2 Hose section of heat exchanger inlet with heat protection hose

Cutting point

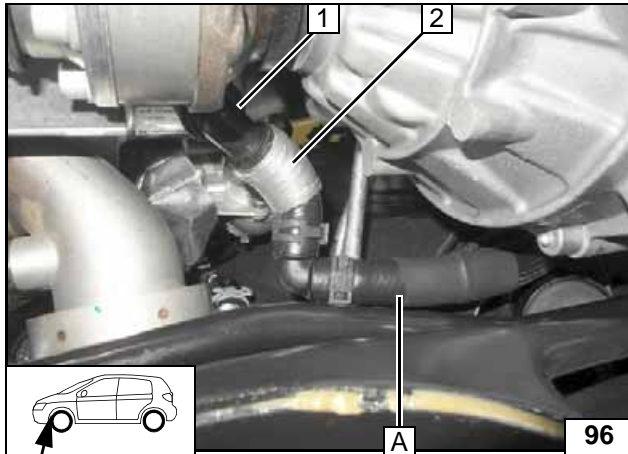


Slide heat protection hose onto hose section of heat exchanger inlet **2**.



- 1 Connection piece of heat exchanger inlet
- 3 Original vehicle spring clip

Connecting heat exchanger inlet

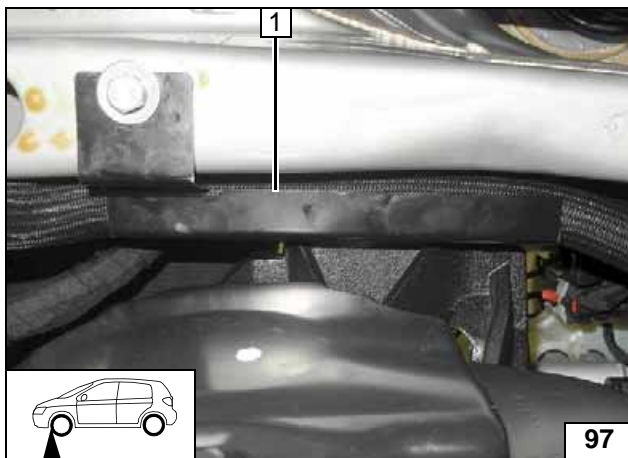


Slide heat protection hose onto hose section of engine outlet **2**. Align hoses. Ensure sufficient distance from neighbouring components, correct if necessary.



- 1 Coupling piece of engine outlet

**Connect-
ing engine
outlet**

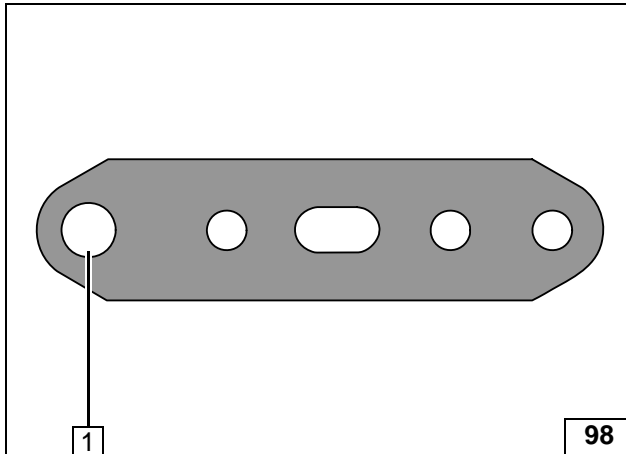
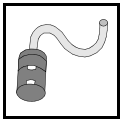


Ensure sufficient distance from neighbouring components, correct if necessary.



- 1 Hose bracket

**Aligning
hose brack-
et**

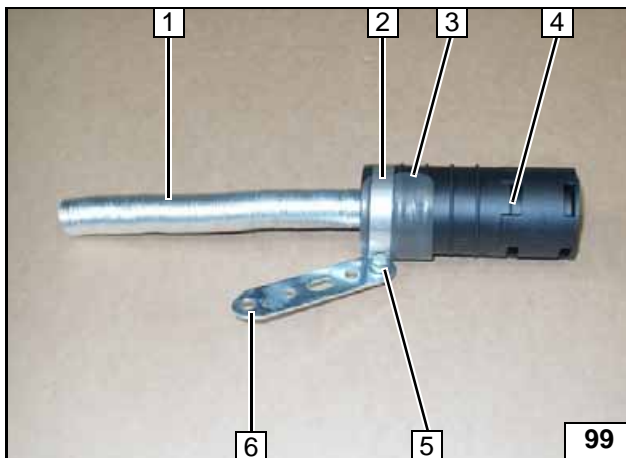


Combustion Air

- 1 Drill out hole to 8.5 mm dia.



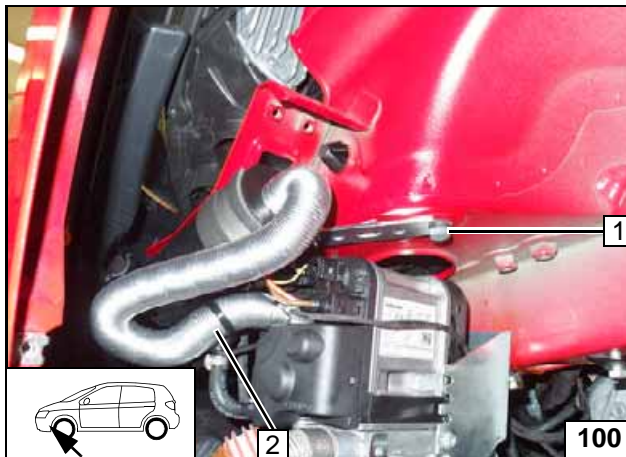
Preparing perforated bracket



- 1 Combustion air pipe
- 2 51mm dia. clamp
- 3 Self-adhesive foam strips
- 4 Silencer
- 5 M5x16 bolt, flanged nut
- 6 Perforated bracket

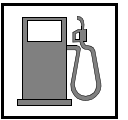


Premounting combustion air pipe and silencer



- 1 M8x20 bolt, spring lockwasher, original vehicle thread
- 2 Combustion air pipe

Installing silencer



Fuel



Open the vehicle's fuel tank cap, ventilate the tank and then re-close the tank lock.

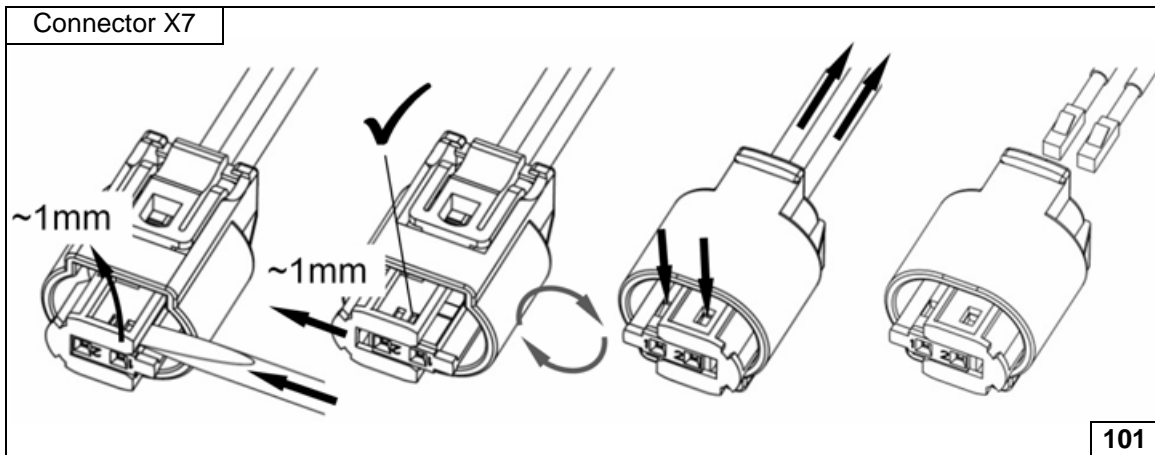
Catch any fuel running off in an appropriate container.



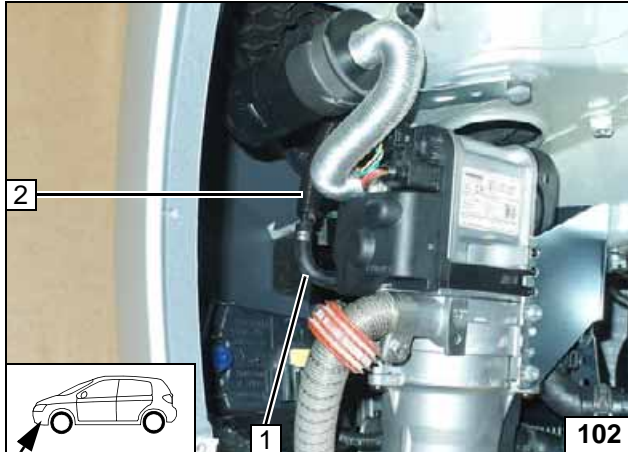
Route fuel line and metering pump wiring harness so that they are protected against stone impact. Unless specified otherwise, always fasten using cable ties.

Provide rub protection for fuel line and wiring harness in areas where there are sharp edges.

The fuel line and wiring harness are routed to the metering pump as shown in the wiring harness routing diagram.



Dismantling metering pump connector

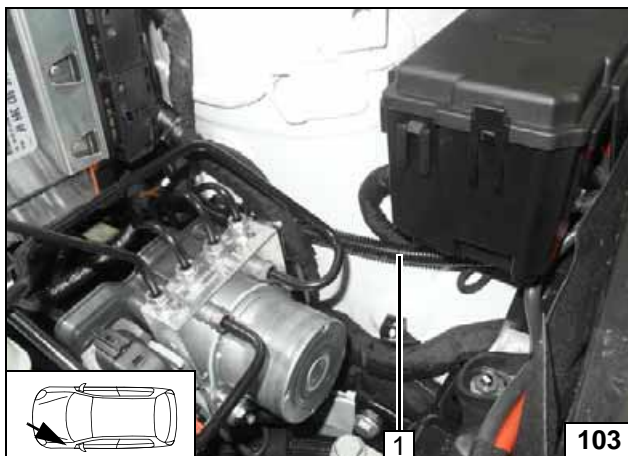


Insert fuel line and metering pump wiring harness into 10mm dia. corrugated tube **2**. Route 10 mm dia. corrugated tube **2** in the engine compartment and secure to combustion air pipe using a cable tie.

- 1** 90° moulded hose, 10mm dia. clamp [2x]

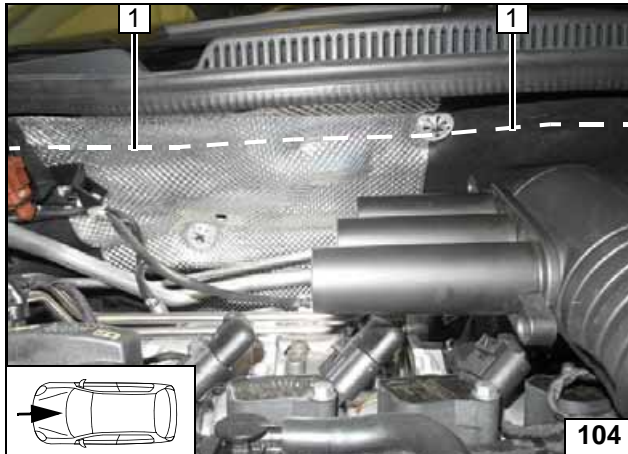


Connecting heater



- 1** Fuel line and wiring harness of metering pump in 10mm dia. corrugated tube

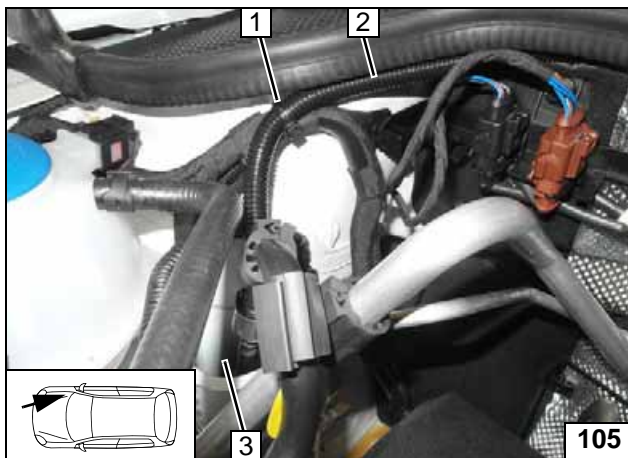
Routing lines



Install the partition wall of the coolant reservoir.
Route fuel line and metering pump wiring harness **1** along the marking behind the insulation mat to the right side of the vehicle.



Routing lines



Route fuel line and wiring harness of metering pump through original vehicle line duct **3** to underbody.



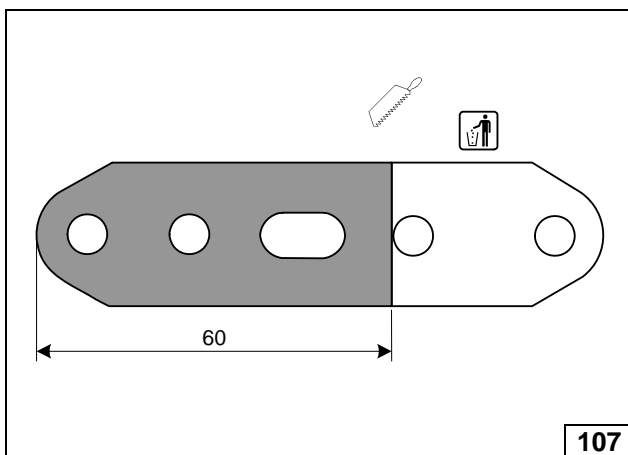
Routing lines

- 1 Cable tie
- 2 Fuel line and wiring harness of metering pump in 10mm dia. corrugated tube

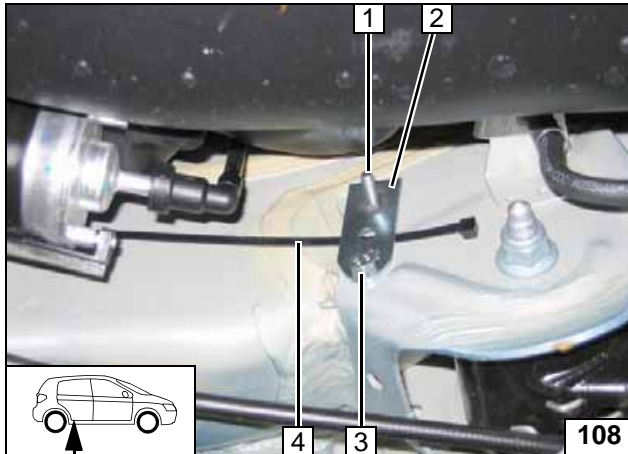


- 1 Fuel line, wiring harness of metering pump
- 2 Original vehicle pass through of fuel lines

Routing lines



Cutting perforated bracket to length

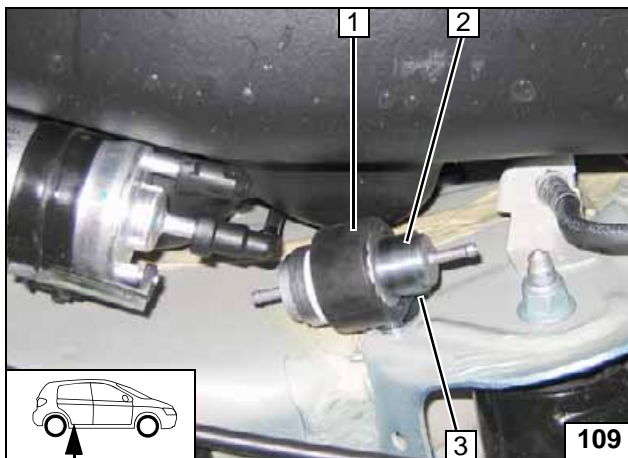


Insert cable tie **4** between perforated bracket **2** and body.

- 1 M6x25 bolt, premount pin lock
- 3 M6x20 bolt, flanged nut, original vehicle hole



Installing perforated bracket

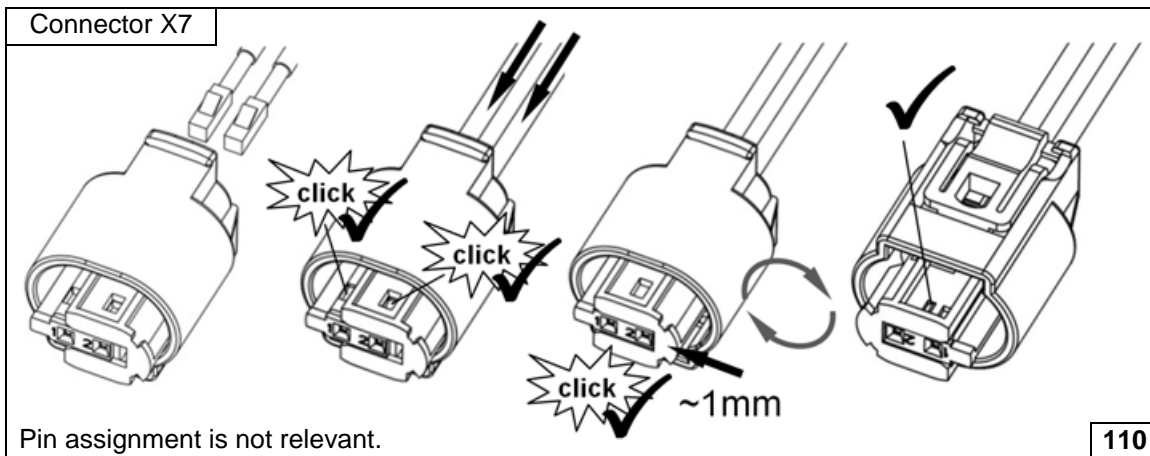


Attach metering pump mount **1** with support angle bracket and flanged nut on M6x25 bolt. Close cable tie **3** around the metering pump mount **1**.

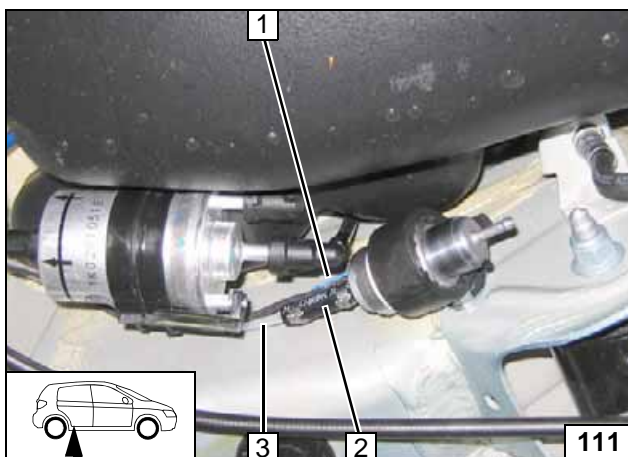
- 2 Metering pump



Installing metering pump



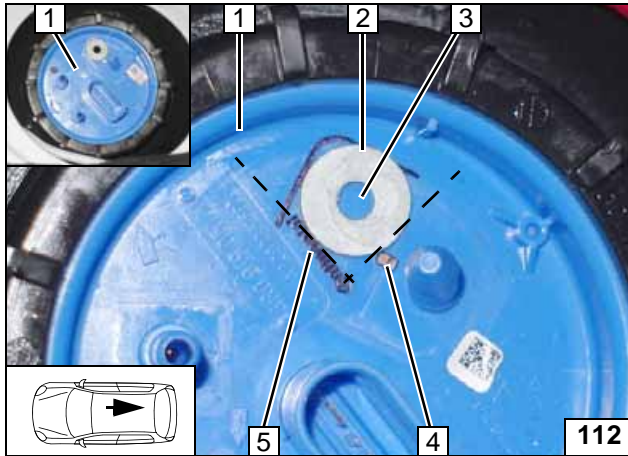
Completing metering pump connector



- 1 Metering pump wiring harness, connector X7 mounted
- 2 Hose section, 10mm dia. clamp [2x]
- 3 Fuel line of heater



Connecting metering pump



FuelFix Installation for Petrol Vehicles

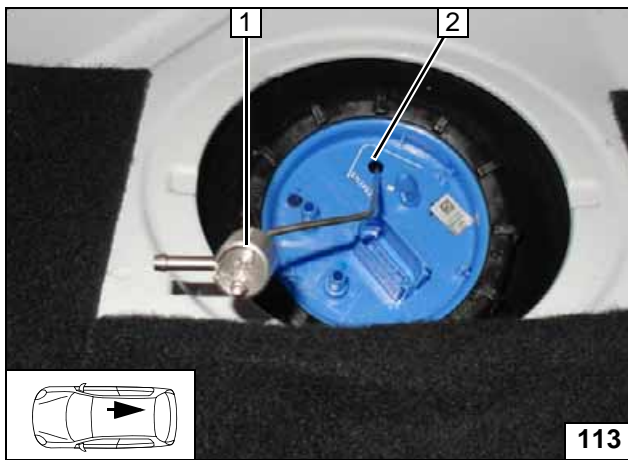
Version 1

Work steps F1, F2 and F3.

- 1 Fuel tank sending unit
- 2 Position washer with outer dia. $d_a = 21.6\text{mm}$ as template, copy hole pattern
- 3 Hole made with provided drill
- 4 Position of raised part
- 5 Position of writing (text may vary)



Hole for FuelFix

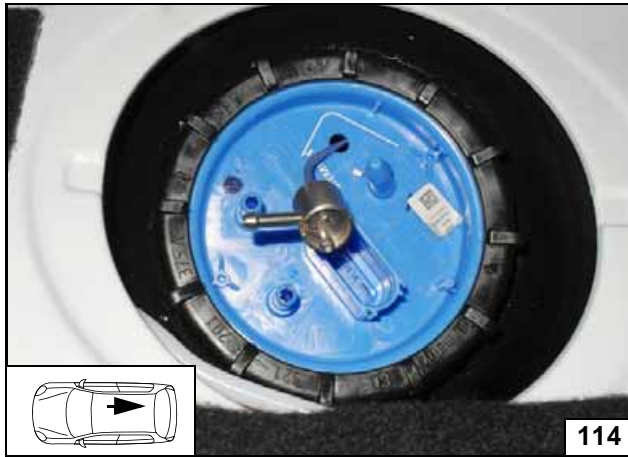


Work steps F4 and F5.

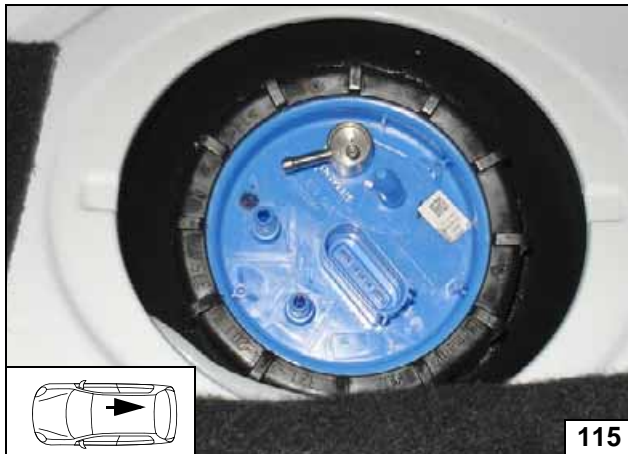
Bend FuelFix 1 according to template and cut to length.
Insert into hole 2.



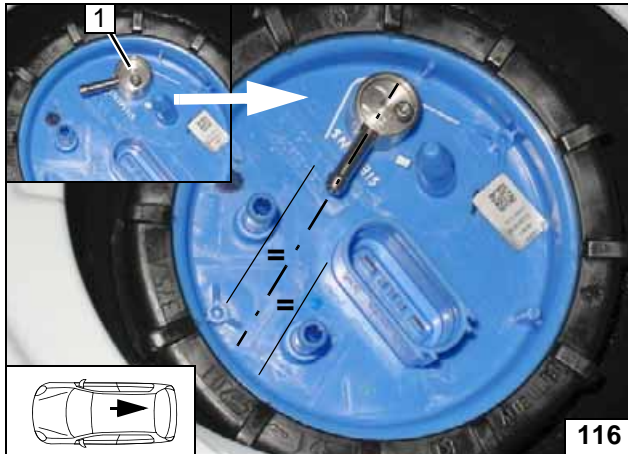
Preparing and inserting FuelFix



Inserting FuelFix



Inserting FuelFix

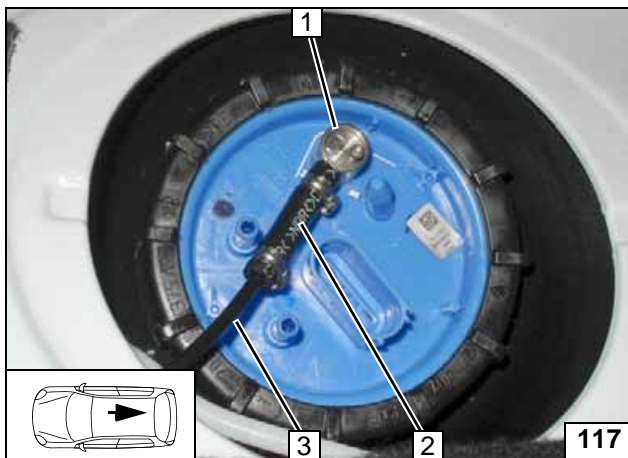


Work steps F5.3 and F5.4.

Align FuelFix as shown.



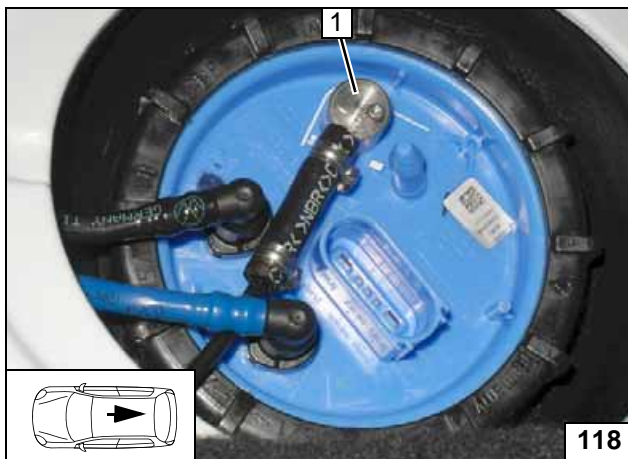
Aligning FuelFix



Work step F6.

- 1 FuelFix
- 2 Hose section, 10mm dia. clamp [2x]
- 3 Fuel line

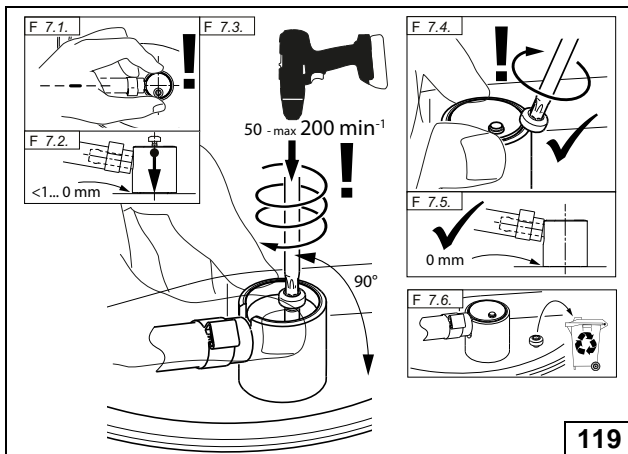
Connecting fuel line



Install original vehicle fuel lines.
Align and install FuelFix 1 as shown in the following figure.



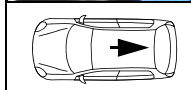
Mounting FuelFix



Work step F7.



Mounting FuelFix

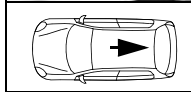
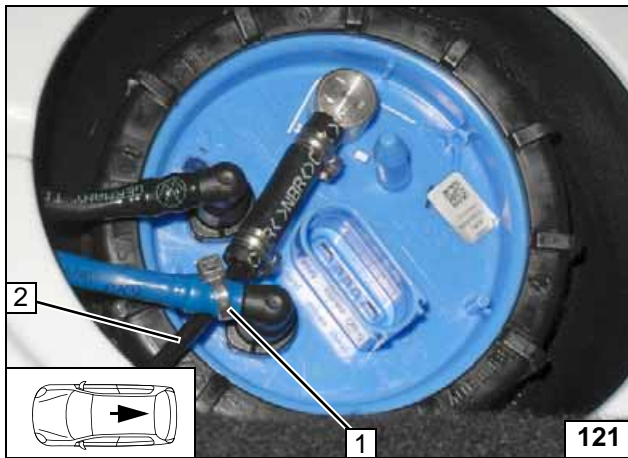


120

Ensuring firm seating of FuelFix

Work step F8.

- 1 Cable tie as tension relief
- 2 Fuel line of FuelFix



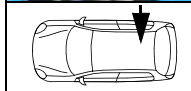
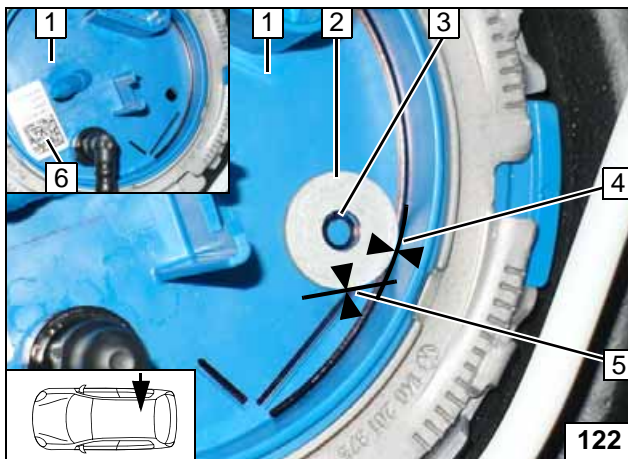
121

Securing fuel line

Version 2

Work steps F1, F2 and F3.

- 1 Fuel tank sending unit
- 2 Position washer with outer dia. $d_a = 21.6\text{mm}$ as template, copy hole pattern
- 3 Hole made with provided drill
- 4 Position at rim of fuel tank sending unit
- 5 Position at end of raised part
- 6 Barcode label, moved



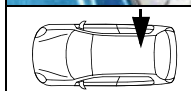
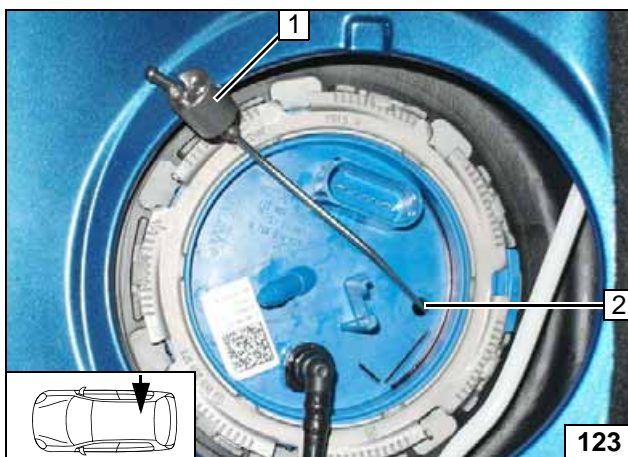
122



Hole for FuelFix

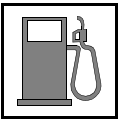
Work steps F4 and F5.

Bend FuelFix 1 according to template and cut to length. Insert into hole 2.



123

Preparing and inserting FuelFix



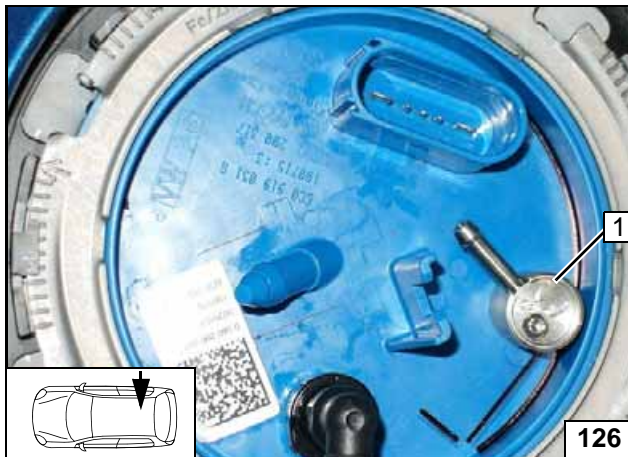
124

Inserting FuelFix



125

Inserting FuelFix



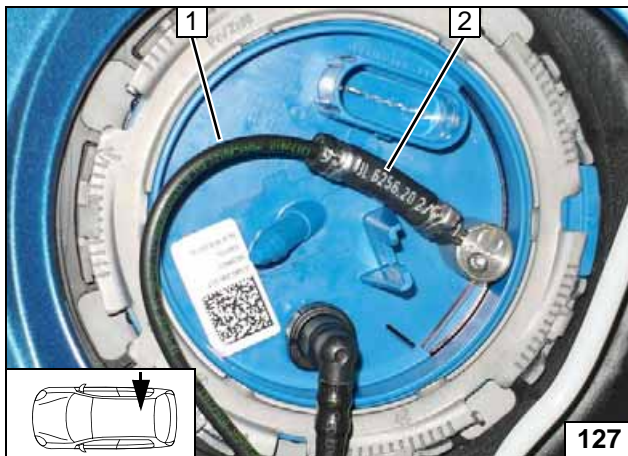
126

Work steps F5.3 and F5.4.

Align FuelFix 1 as shown.



Aligning FuelFix



127

Work step F6.

- 1 Fuel line
- 2 Hose section, 10mm dia. clamp [2x]

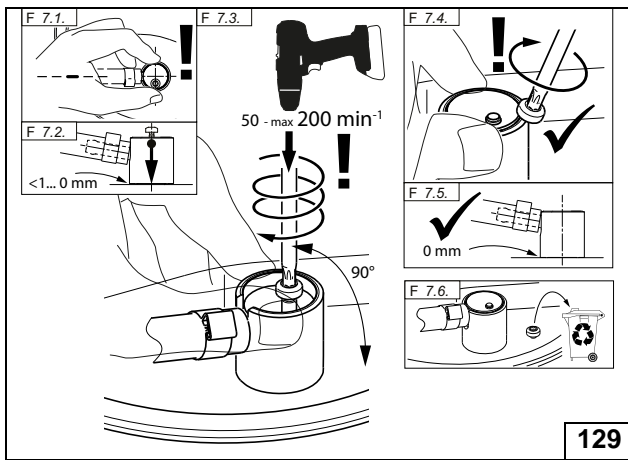
Connecting fuel line



Install original vehicle connector.
Align and install FuelFix 1 as shown in the following figure.



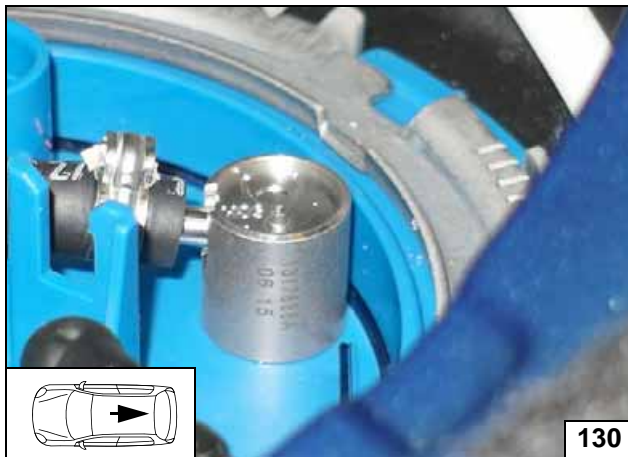
Mounting FuelFix



Work step F7.

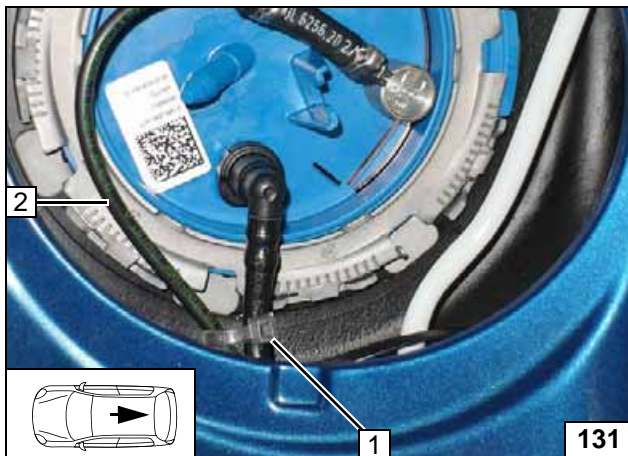


Mounting FuelFix



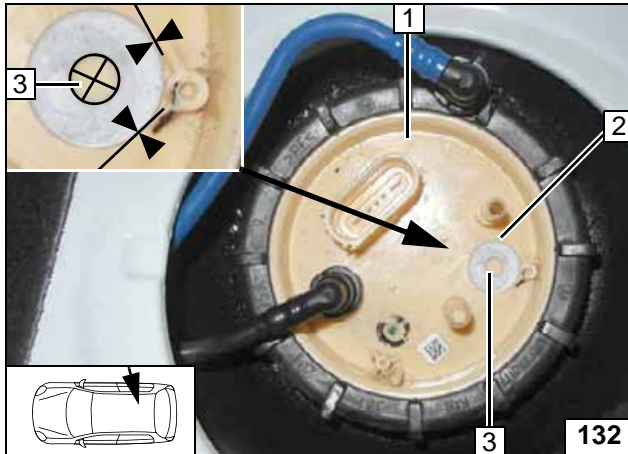
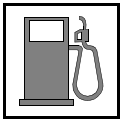
Work step F8.

Ensuring firm seating of FuelFix



- 1 Cable tie as tension relief
- 2 Fuel line of FuelFix

Securing fuel line



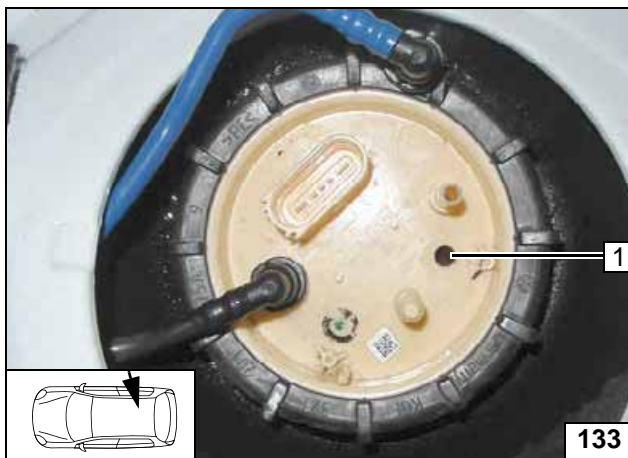
FuelFix Installation for Diesel Vehicles

Work steps F1 and F2.

- 1 Fuel tank sending unit
- 2 Position washer with outer dia. $d_a = 21.6\text{mm}$ as template against the raised parts.
- 3 Hole pattern



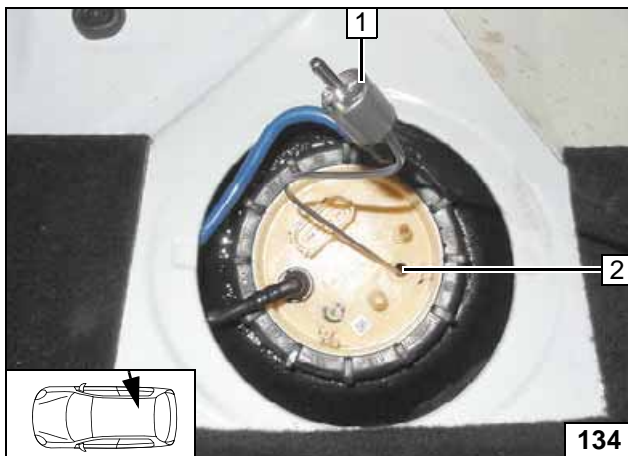
Fuel extraction



Work step F3.

- 1 Hole made with provided drill

Hole for FuelFix



Work steps F4 and F5.

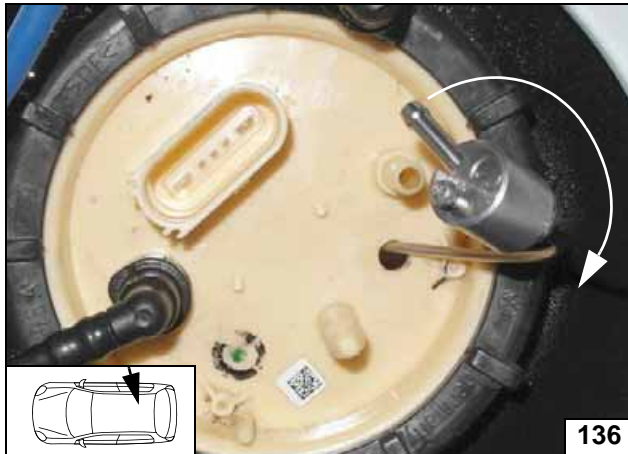
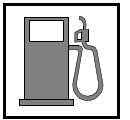
Bend FuelFix 1 according to template and cut to length.
Insert into hole 2.



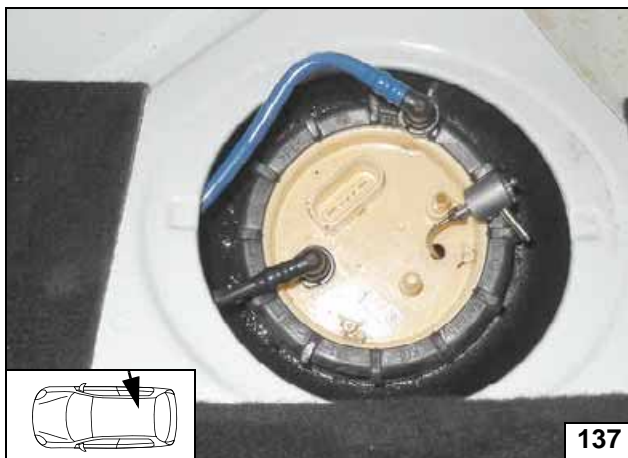
Inserting FuelFix



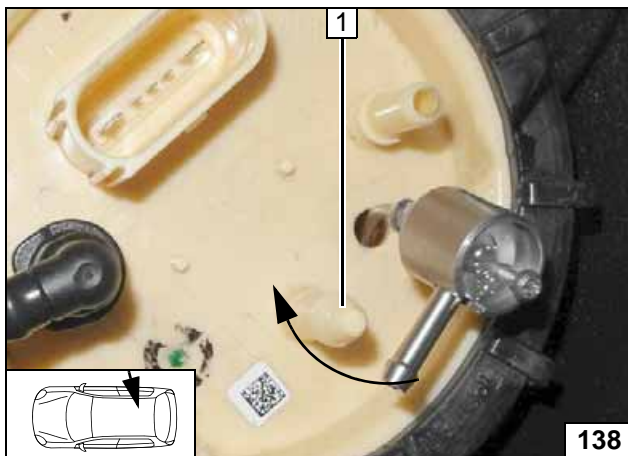
Inserting FuelFix



Inserting FuelFix



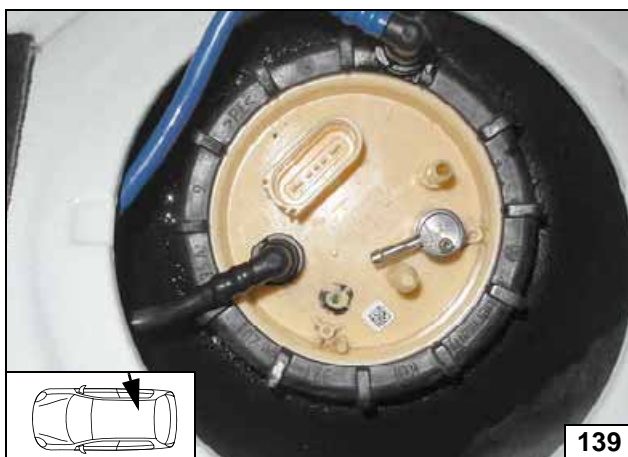
Inserting FuelFix



Move FuelFix connection piece over closed stub 1.



Inserting FuelFix

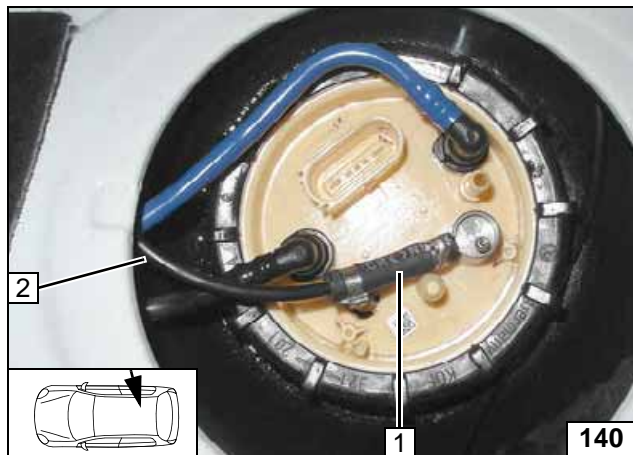


Work steps F5.3 and F5.4.

Turn FuelFix in position as shown.



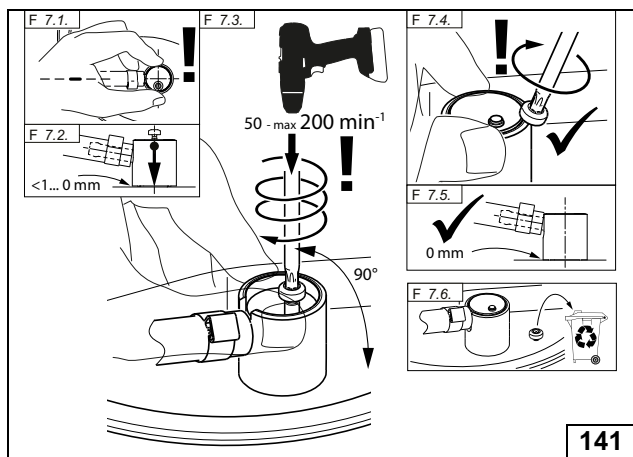
Positioning FuelFix



Work step F6.

- 1 Hose section, 10mm dia. clamp [2x]
- 2 Fuel line

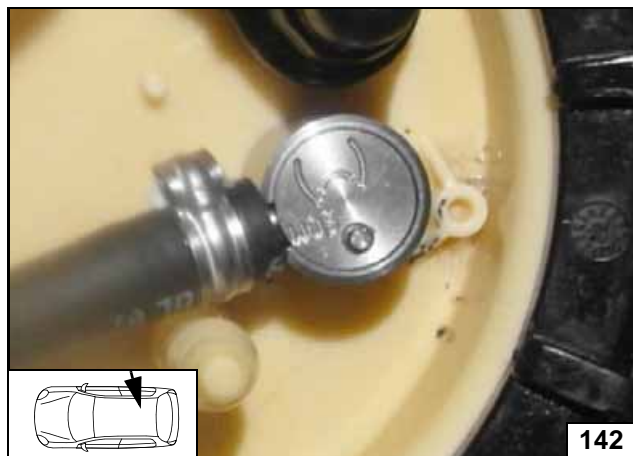
Connect-
ing fuel line



Work step F7.

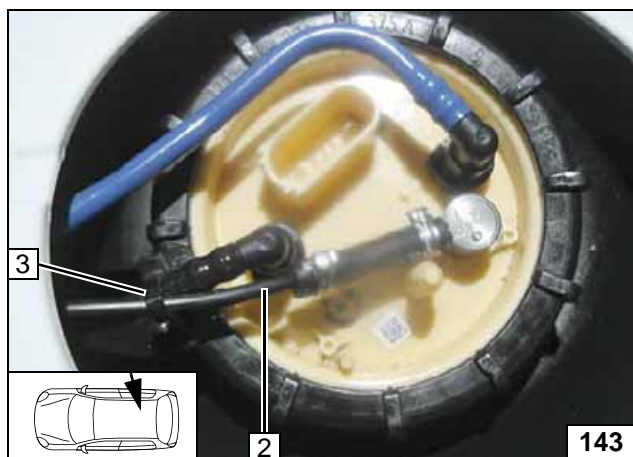


Mounting
FuelFix



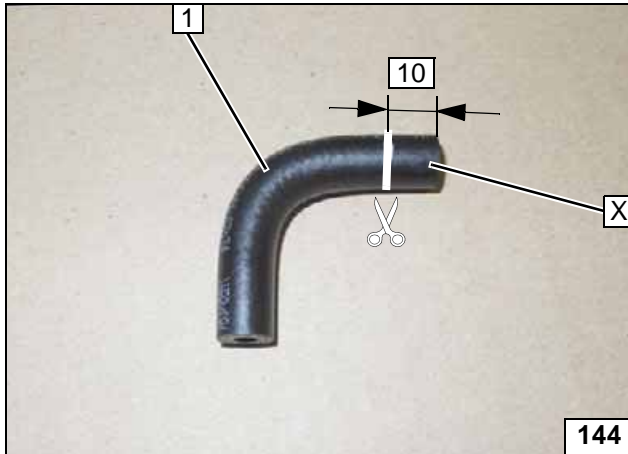
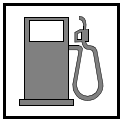
Work step F8.

Ensuring
firm seating
of FuelFix



- 1 FuelFix installed
- 2 Fuel line of FuelFix
- 3 Cable tie as tension relief

Securing
fuel line



All vehicles

- 1 90° moulded hose

X =



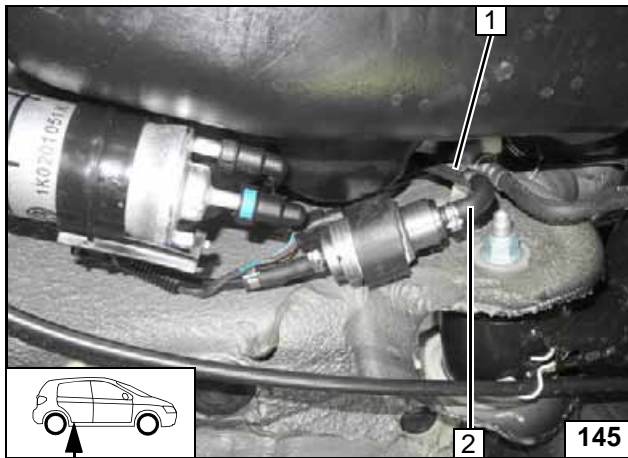
**Cutting
moulded
hose to
length**

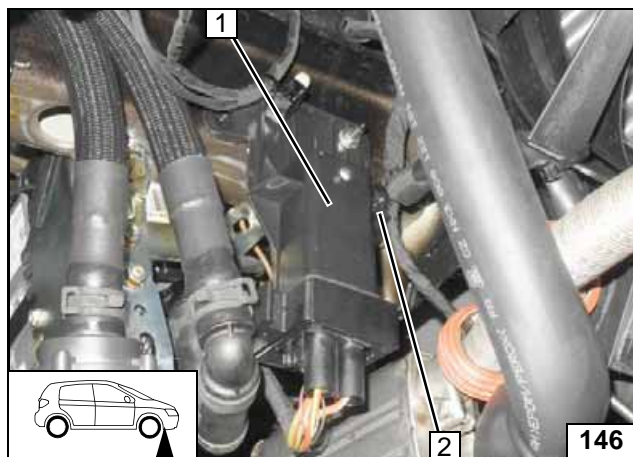
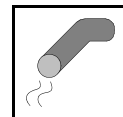
Check the position of the components; adjust if necessary. Check that they have freedom of movement.



- 1 Fuel line of FuelFix
- 2 90° moulded hose, 10mm dia. clamp [2x]

**Connect-
ing meter-
ing pump**



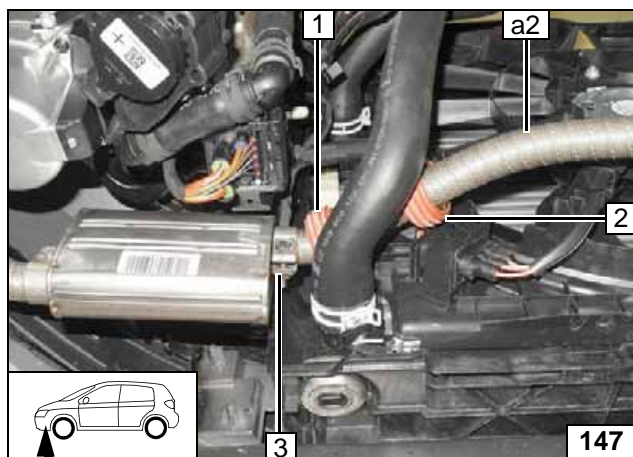


Exhaust Part 2

- 1 Re-attach original vehicle relay turned by 180°
- 2 Clip-type cable tie on relay, original vehicle wiring harness



**Re-attach-
ing relay
and wiring
harness**



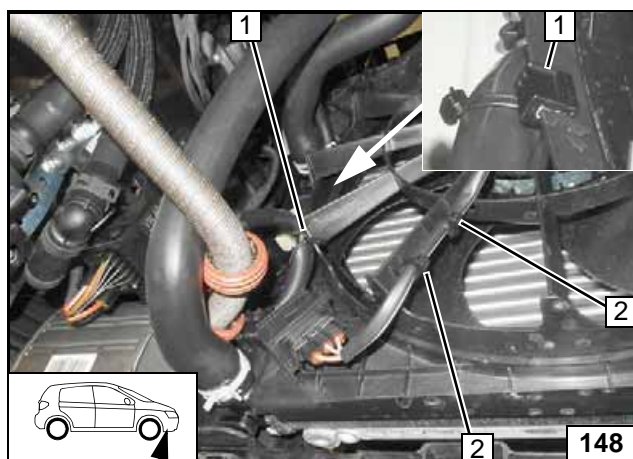
Petrol

1.0 MPi

- 1 Spacer bracket, align with coolant hose
- 2 Spacer bracket, align with connector
- 3 Hose clamp

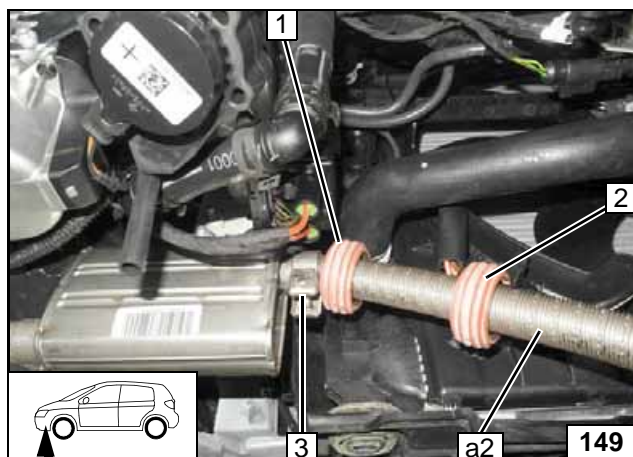


**Installing
exhaust
pipe a2**



- 1 Edge clip cable tie
- 2 Cable tie [2x]

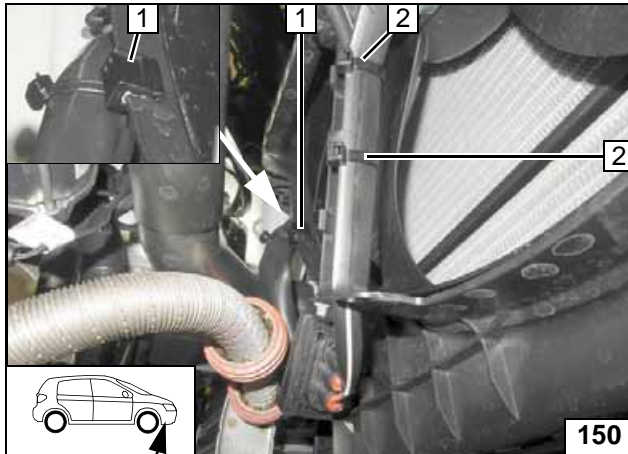
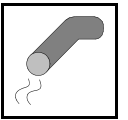
**Securing
wiring har-
ness**



1.2 TSi

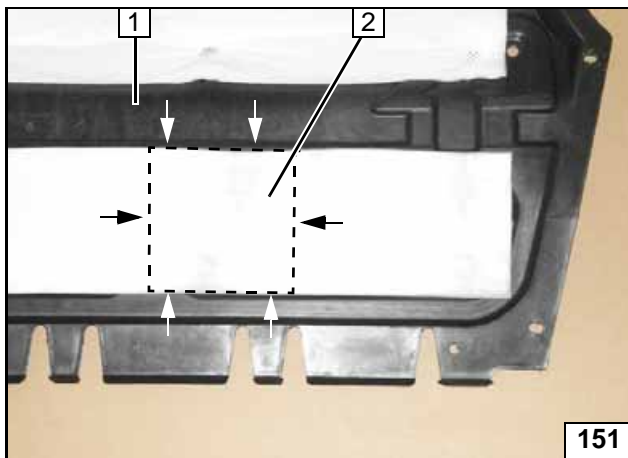
- 1 Spacer bracket, align with coolant hose
- 2 Spacer bracket, align with connector
- 3 Hose clamp

**Installing
exhaust
pipe a2**



- 1 Edge clip cable tie
- 2 Cable tie [2x]

Securing wiring harness



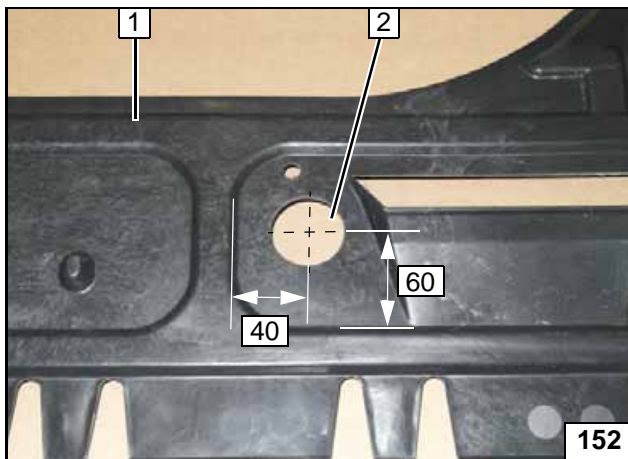
All petrol vehicles

Remove marked area of insulation mat 2 (if present).

- 1 Underride protection



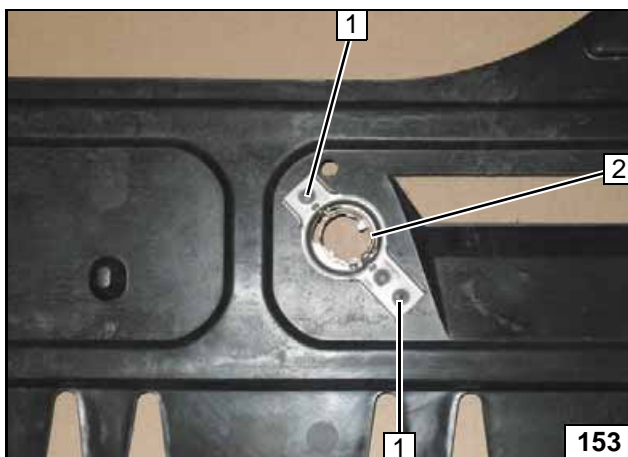
Removing insulation mat



- 1 Underride protection
- 2 Hole (as per work step 1 of the installation instructions)



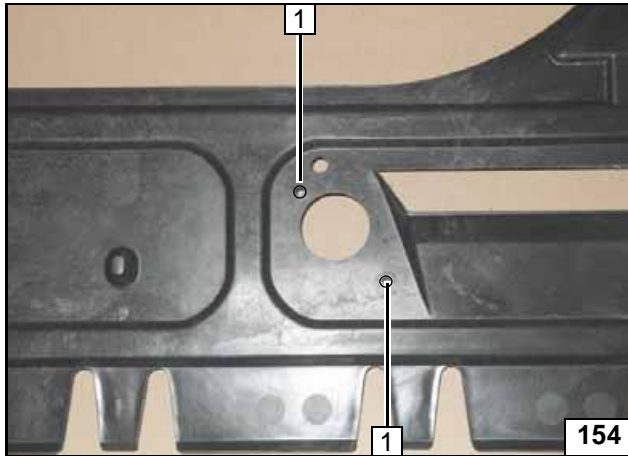
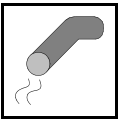
Hole in underride protection



Position exhaust end fastener 2 as per work step 3 of the installation instructions and copy hole pattern 1 [2x].



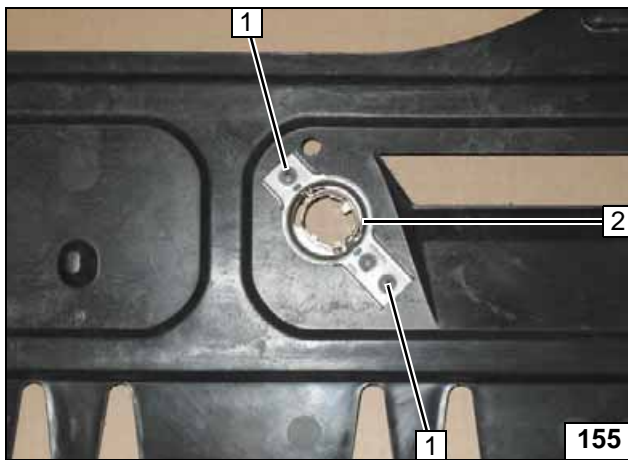
Copying hole pattern



Hole 1 [2x] as per work step 4 of the installation instructions.



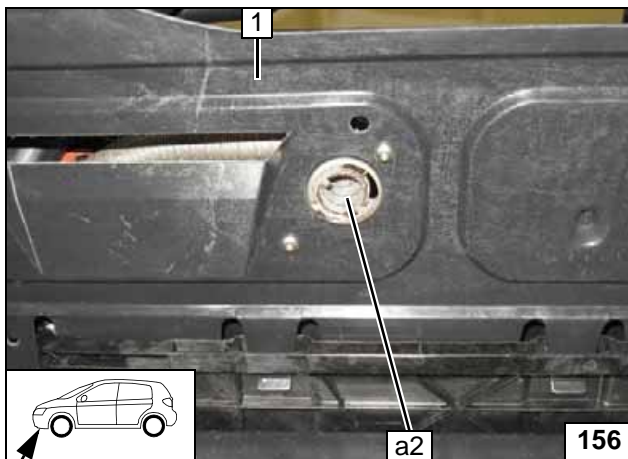
Holes in underride protection



- 1 Self-tapping screw 5x13 [2x] as per work step 5 of the installation instructions
- 2 Exhaust end fastener



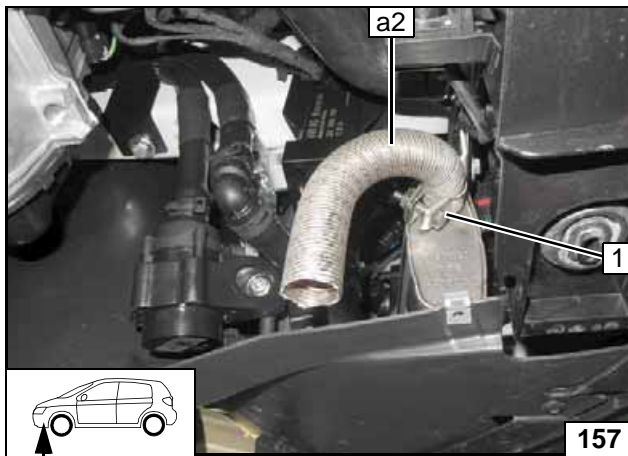
Installing exhaust end fastener



Install underride protection 1.
Install exhaust pipe a2 as per work steps 6 - 8 of the installation instructions.



Installing exhaust pipe a2

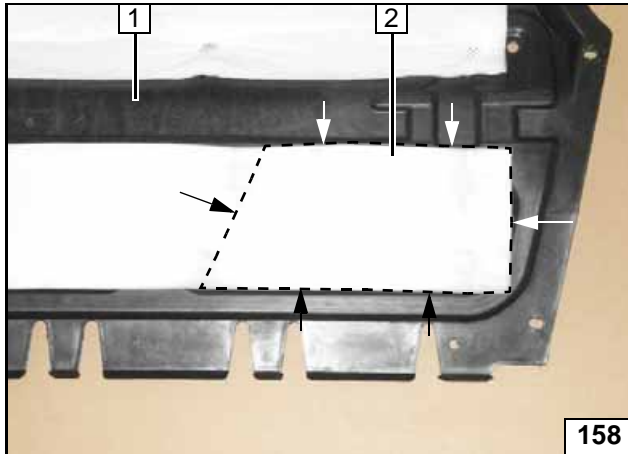
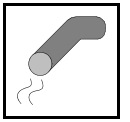


Diesel

- 1 Hose clamp



Installing exhaust pipe a2

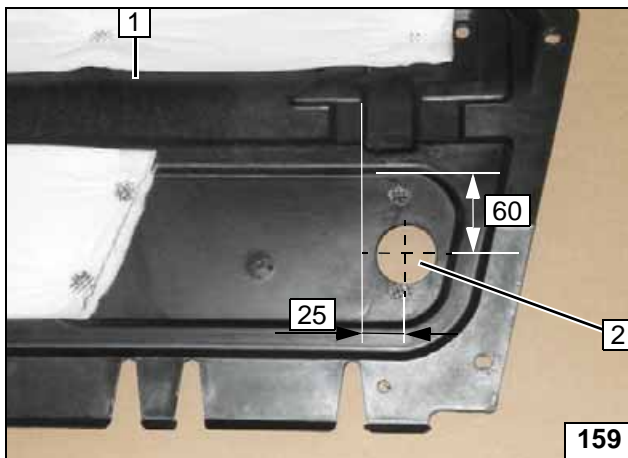


Remove marked area **2** of the insulation mat.

- 1 Underride protection



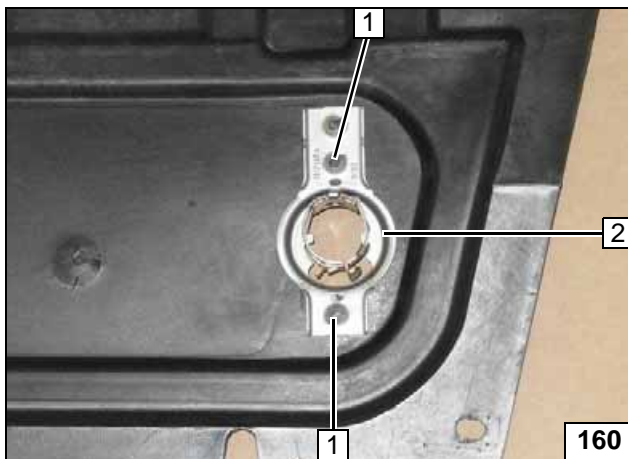
Removing insulation mat



- 1 Underride protection
- 2 Hole (as per work step 1 of the installation instructions)



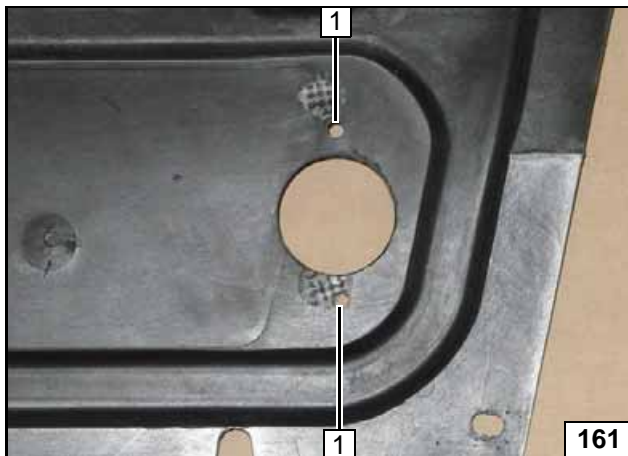
Hole in underride protection



Position exhaust end fastener **2** as per work step 3 of the installation instructions and copy hole pattern **1** [2x].



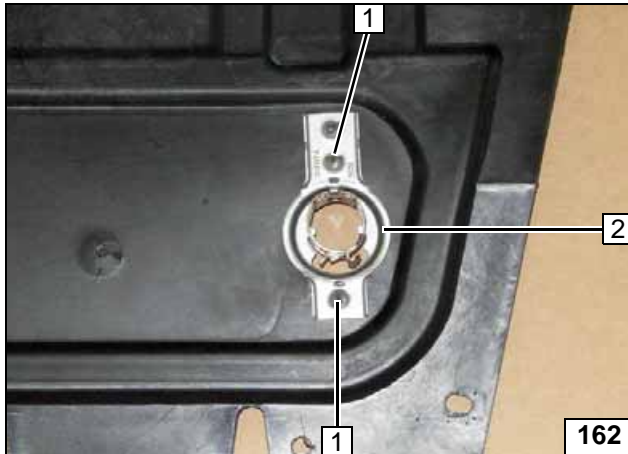
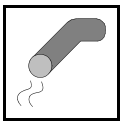
Copying hole pattern



Hole **1** [2x] as per work step 4 of the installation instructions.



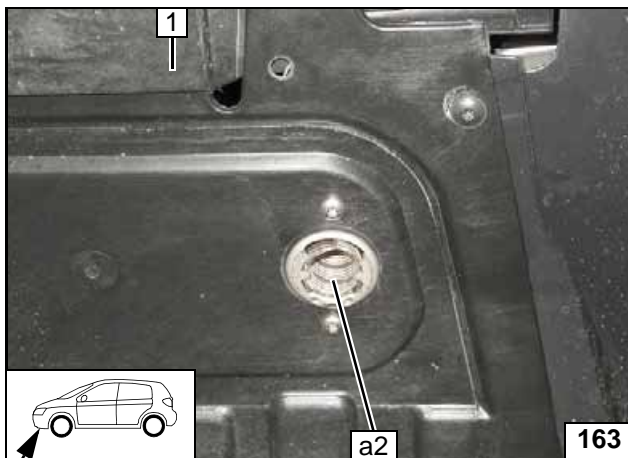
Holes in underride protection



- 1 Self-tapping screw 5x13 [2x] as per work step 5 of the installation instructions
- 2 Exhaust end fastener



Installing exhaust end fastener



Install underide protection 1. Install exhaust pipe a2 as per work steps 6 - 8 of the installation instructions.



Installing exhaust pipe a2



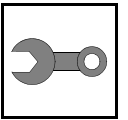
All vehicles

Cut self-adhesive heat protection film 2 in the middle, stick on as shown.

- 1 Wheel-well inner panel on the left



Sticking on heat protection film

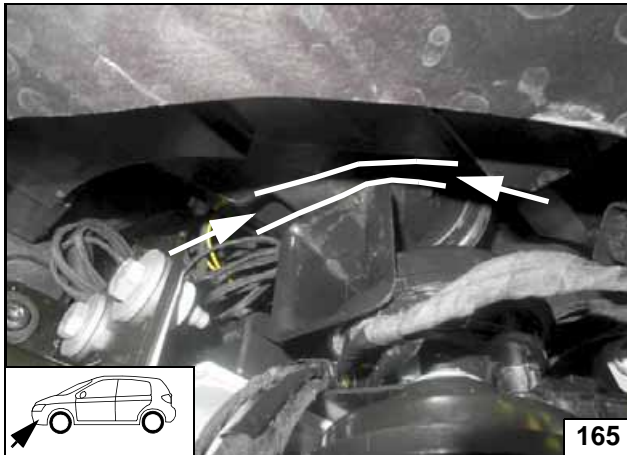


Final Work

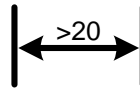


Reassemble the components in reverse order. Check all hoses, clamps and all electrical connections for firm seating. Insulate and tie back loose lines. Only use manufacturer-approved coolant. Spray the heater components with anti-corrosion wax (Tectyl 100K).

- Connect the battery.
- Fill and bleed the coolant circuit according to the vehicle manufacturer's specifications.
- Program MultiControl CAR, teach Telearstart transmitter.
- Make settings on A/C control panel according to the 'Operating Instructions for End Customer'.
- Place the 'Switch off parking heater before refuelling' caution label near the filler neck.
- For initial startup and function check, please see installation instructions.



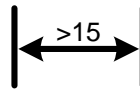
After the headlight installation, check the distance from the horn and after the bumper trim installation check the distance between the wiring harnesses of the horns as well as the front fog lights and the exhaust system, correct if necessary.



Checking distance

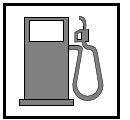


Figure shows 1.0 MPI.



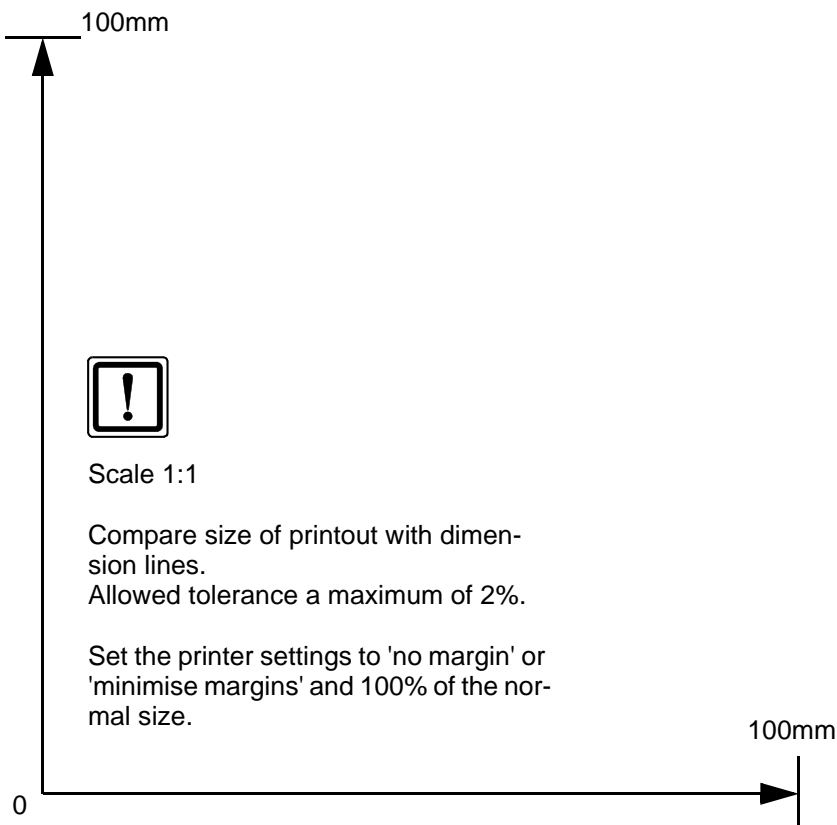
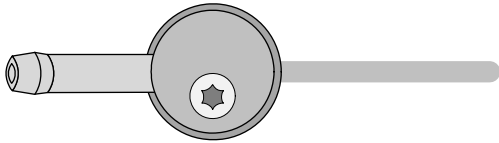
Aligning silencer

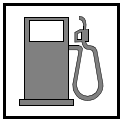
Webasto Thermo & Comfort SE
 Postfach 1410
 82199 Gilching
 Germany
 Internet: www.webasto.com
 Technical Extranet:
 http://dealers.webasto.com



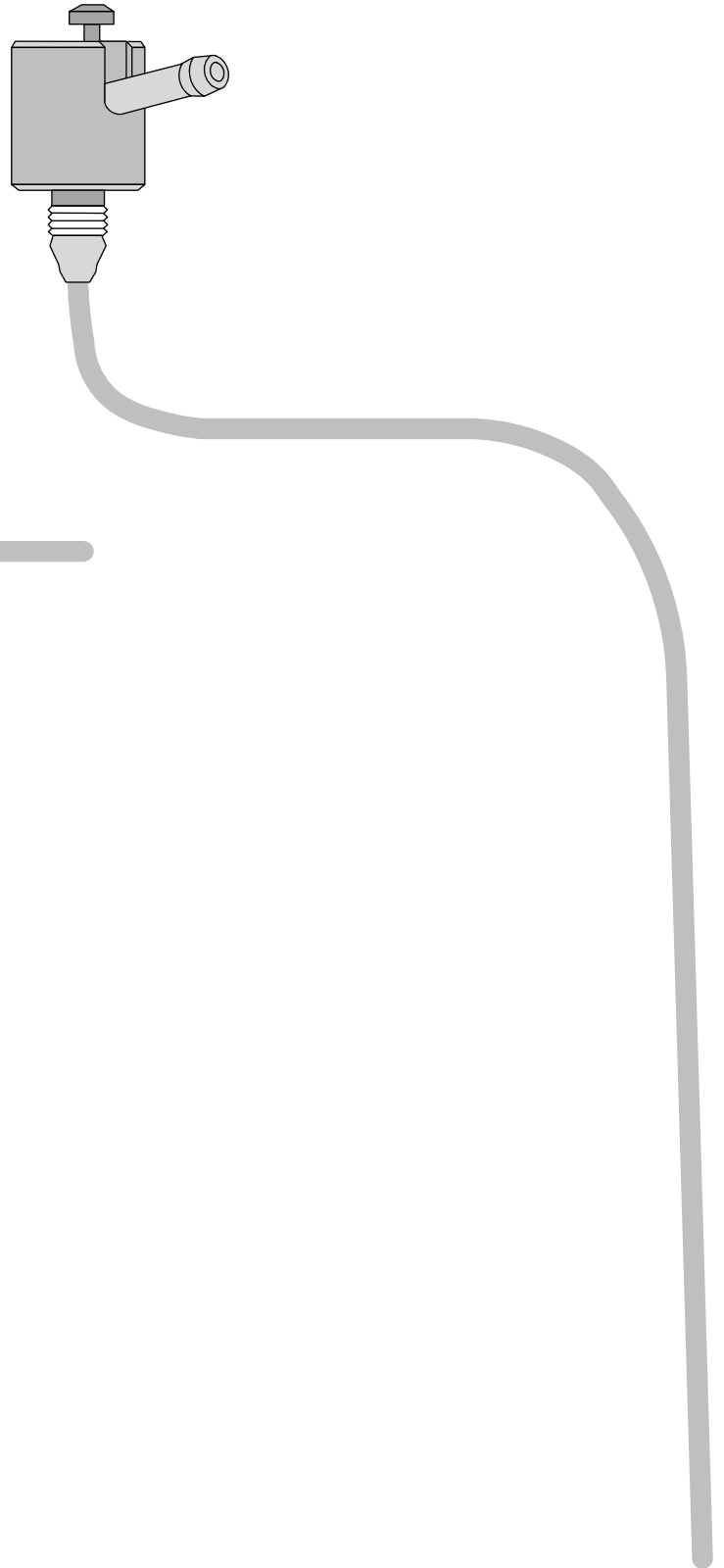
FuelFix Template for Petrol Vehicle

Top view

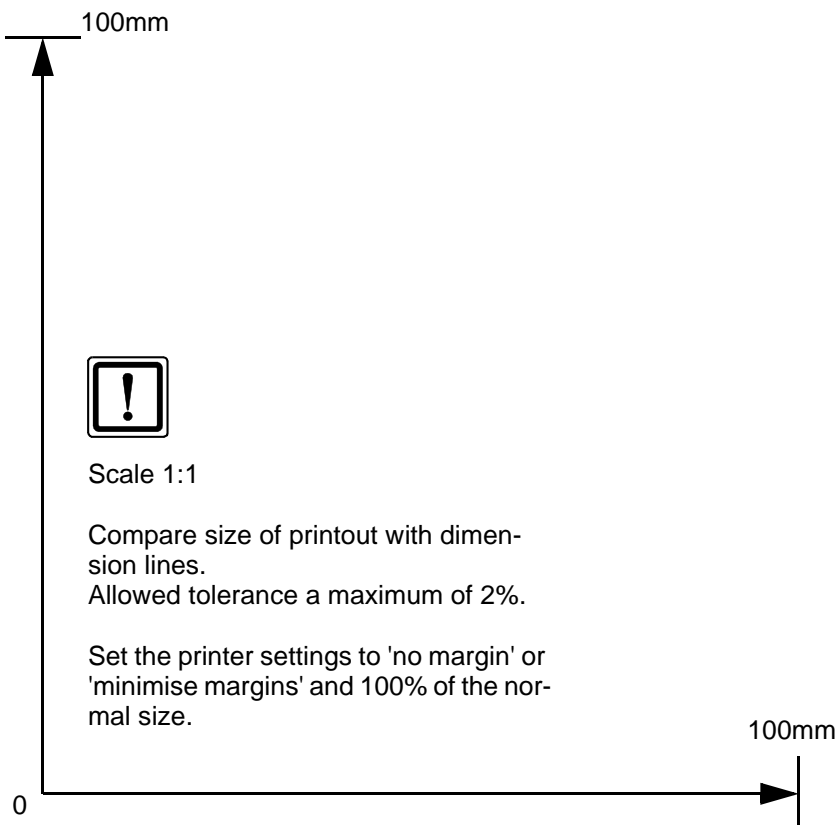




FuelFix Template for Diesel Vehicle



Top view



Operating Instructions for Manual Air-Conditioning

Please remove page and add to the vehicle operating instructions.

Note:

We recommend matching the heating time to the driving time.

Heating time = driving time

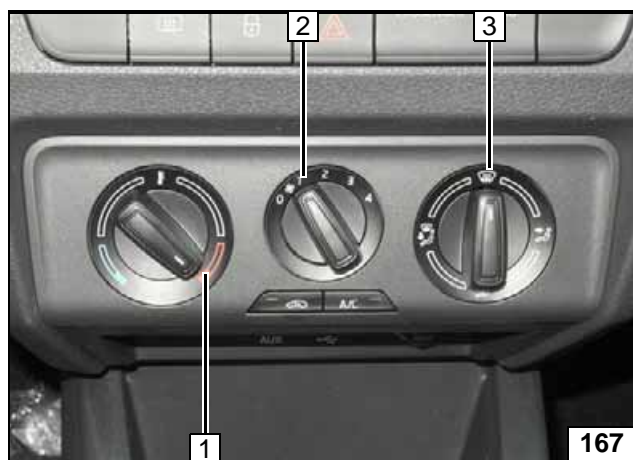
Example:

For a driving time of approx. 20 min. (in one direction), we recommend not exceeding a switch-on time of 20 min.

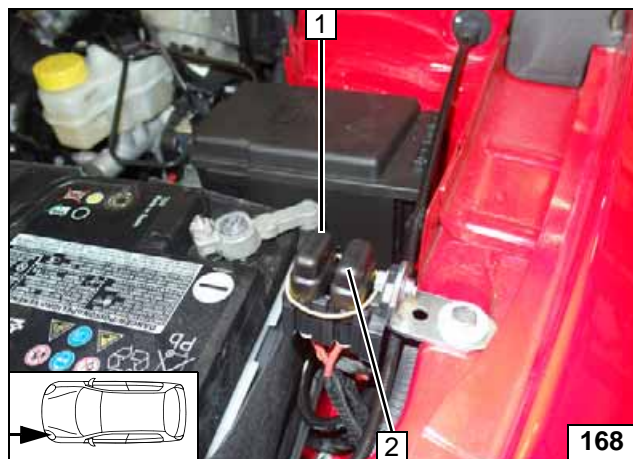
Passenger compartment monitoring, if installed, must be deactivated in addition to the vehicle settings for the heating operation.

For instructions on deactivation, please refer to the operating instructions of the vehicle.

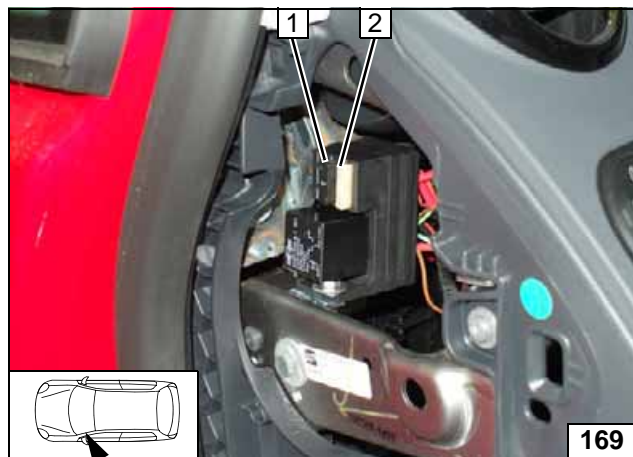
Before parking the vehicle, make the following settings:



- 1 Set temperature to 'max.'
- 2 Set fan to level '1', or max. '2'
- 3 Air outlet to windscreen



- 1 20A heater fuse F1
- 2 30A passenger compartment main fuse F2



- 1 1A heater control fuse F3
- 2 25A fan fuse F4



Air-conditioning control panel

Engine compartment fuses

Passenger compartment fuses



Operating Instructions for Automatic Air-Conditioning

Please remove page and add to the vehicle operating instructions.

Note:

We recommend matching the heating time to the driving time.

Heating time = driving time

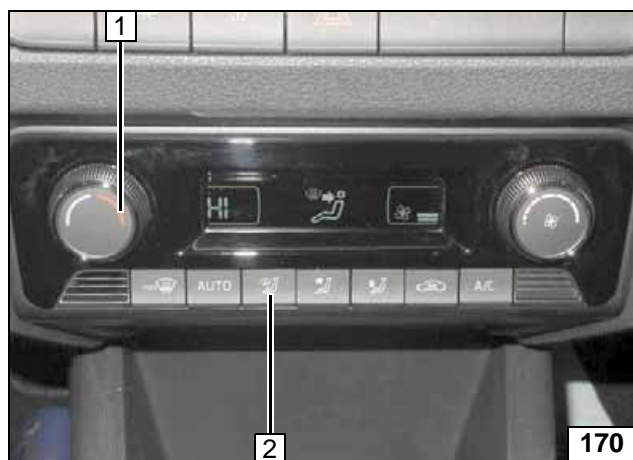
Example:

For a driving time of approx. 20 min. (in one direction), we recommend not exceeding a switch-on time of 20 min.

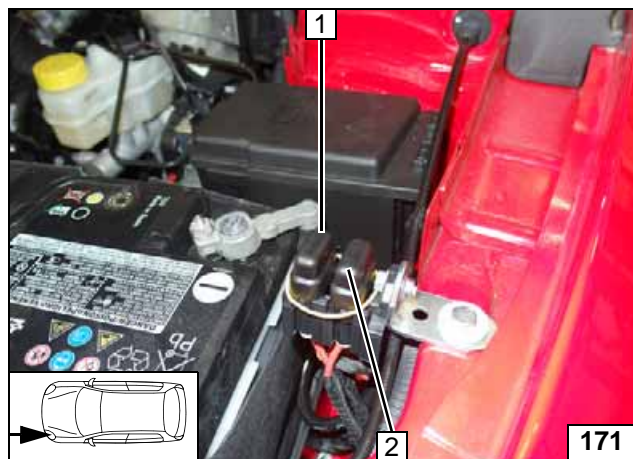
Passenger compartment monitoring, if installed, must be deactivated in addition to the vehicle settings for the heating operation.

For instructions on deactivation, please refer to the operating instructions of the vehicle.

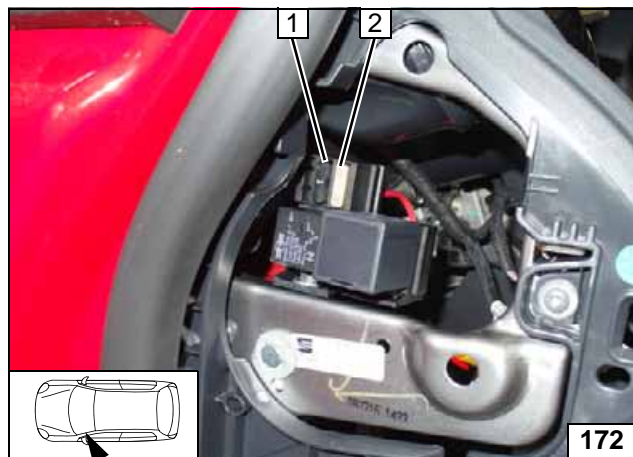
Before parking the vehicle, make the following settings:



- 1 Set temperature to 'HI'
- 2 Air outlet to windscreen



- 1 20A heater fuse F1
- 2 30A passenger compartment main fuse F2



- 1 1A heater control fuse F3
- 2 25A fan fuse F4



Air-conditioning control panel

Engine compartment fuses

Passenger compartment fuses

