



Water Heater

Thermo Top Evo Parking Heater



With FuelFix

Installation Documentation Suzuki Vitara

Validity

Manufacturer	Model	Type	EG BE No. / ABE
Suzuki	Vitara	LY	e4 * 2007 / 46 * 0928 * 02

Motorisation	Fuel	Transmission type	Output in kW	Displacement in cm ³	Engine code
1.6 D	Diesel	DKG	88	1598	D16AA

DKG = dual clutch transmission (TCSS)

From model year 2015
Left-hand drive vehicle

Verified equipment variants: Manual air-conditioning
Automatic air-conditioning
Front fog lights
Daytime running lights (LED and Halogen)
LED main headlights
Euro 6
2WD / 4WD
Keyless start
Start / Stop

Not verified: Alarm system

Total installation time: about 10 hours

Suzuki Vitara

Table of Contents

Validity	1	Preparing Installation Location	19
Necessary Components	2	Preparing Heater	22
Installation Overview	2	Installing Heater	23
Information on Total Installation Time	2	Coolant Circuit	24
Information on Operating and Installation Instructions	3	Fuel	29
Information on Validity	4	Installing FuelFix	30
Technical Information	4	Combustion Air	35
Explanatory Notes on Document	4	Exhaust Gas	36
Preliminary Work	5	Final Work	40
Heater Installation Location	5	Template for FuelFix	41
Preparing Electrical System	6	Operating Instructions for Manual Air-Conditioning	42
Electrical System	9	Operating Instructions for Automatic Air-Conditioning	43
Manual Air-Conditioning Fan Controller	11		
Automatic Air-Conditioning Fan Controller	13		
HVAC Installation Aid	14		
MultiControl CAR Option	17		
Remote Option (Telestart)	17		
ThermoCall Option	18		

Necessary Components

- Basic delivery scope of Thermo Top Evo based on price list
- Installation kit with FuelFix for Suzuki Vitara 2015 Diesel: **1324871A**
- To be ordered additionally in case of automatic A/C: Additional kit for automatic A/C: **1324331_**
- Heater control in accordance with price list and upon consultation with end customer
- In case of Telestart, indicator lamp in accordance with price list and in consultation with end customer

Installation instructions:

- Arrange for the vehicle to be delivered with the tank only about $\frac{1}{4}$ full.
- The installation location of the push button in case of Telestart or Thermo Call should be confirmed with the end customer.
- Depending on the space required and the manufacturer's instructions, we recommend the use of a vehicle battery with a higher electrical capacity.

Installation Overview

Legend:

1. Heater
2. Engine compartment fuse holder
3. Passenger compartment relay and fuse holder
4. Circulating pump
5. MultiControl CAR
6. Metering pump
7. FuelFix

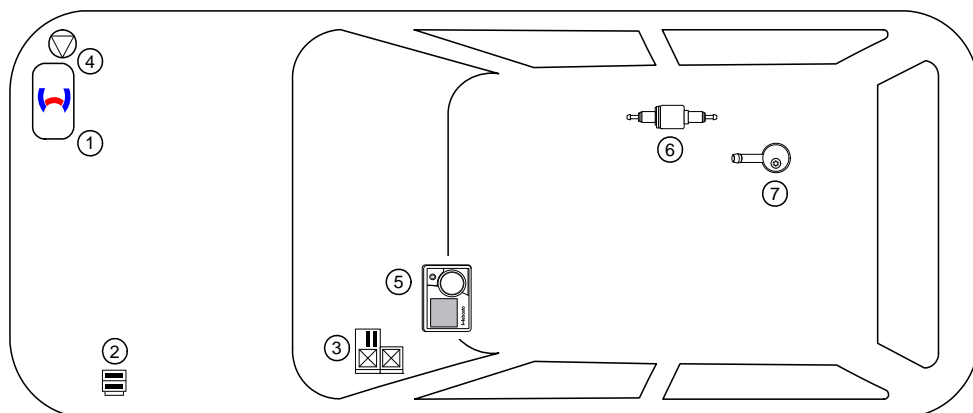

Information on Total Installation Time

The total installation time includes the time needed for mounting and demounting the vehicle-specific components, the heater specific installation time and all other times required for the system integration and initial start-up of the heater. The total installation time may vary for vehicle equipment other than provided.

Information on Operating and Installation Instructions

1 Important information (not complete)

1.1 Installation and repair



The improper installation or repair of Webasto heating and cooling systems can cause fire or the leakage of deadly carbon monoxide, leading to serious injury or death.



To install and repair Webasto heating and cooling systems you need to have completed a special company training course and have the appropriate technical documentation, special tools and special equipment.



Installation and repair may ONLY be carried out by persons trained and certified in a Webasto training course. NEVER try to install or repair Webasto heating or cooling systems if you have not completed a Webasto training course, you do not have the necessary technical skills and you do not have the technical documentation, tools and equipment available to ensure that you can complete the installation and repair work properly.

Only use genuine Webasto parts. See the Webasto air and water heaters accessories catalogue for this purpose.

1.2 Operation

To ensure safe operation, we recommend having the heater checked every two years by an authorised Webasto dealer, especially when used over a long period and/or under extreme environmental conditions.

Do not operate the heater in closed rooms due to the danger of poisoning and suffocation.

Always switch off the heater before refuelling.

The heater may only be used with the prescribed fuel diesel (DIN EN 590) or petrol (DIN EN 228).

The heater may not be cleaned with a high-pressure cleaner.

1.3 Please note

ALWAYS follow all Webasto installation and operating instructions and observe all warnings.

To become familiar with and understand all functions and properties of the heater, the operating instructions must be read carefully and observed at all times.

For proper, safe installation and repair work, the installation instructions with all warnings and safety information must be carefully read and observed at all times. Please always contact a workshop authorised by Webasto for all installation and repair work.

Important

Webasto shall assume no liability for defects, damage and injuries resulting from a failure to observe the installation, repair and operating instructions of the information contained in them.

This liability exclusion particularly applies to improper installations and repairs, installations and repairs by untrained persons or in the case of a failure to use genuine spare parts.

The liability due to culpable disregard to life, limb or health and due to damage or injuries caused by a wilful or reckless breach of duty remain unaffected, as does the obligatory product liability.

Installation should be carried out according to the general, standard rules of technology. Unless specified otherwise, fasten hoses, lines and wiring harnesses to original vehicle lines and wiring harnesses using cable ties. Insulate loose wire ends and tie back. Connectors on electronic components have to audibly click into place during installation.

Sharp edges should be fitted with rub protection. Spray unfinished body areas, e.g. drilled holes, with anti-corrosion wax (Tectyl 100K).

Observe the instructions and guidelines of the respective vehicle manufacturer for demounting and mounting vehicle specific components!

The initial startup is to be executed with the Webasto Thermo Test Diagnosis.

When installing a programmable control module (e.g. a PWM Gateway), the corresponding settings must be checked or adjusted.

2 Statutory regulations governing installation

Guidelines	Thermo Top Evo
Heating Directive ECE R122	E1 00 0258
EMC Directive ECE R10	E1 04 5627

Note

The regulations of these guidelines are binding in the scope of the Directive 70/156/EEC and/or 2007/46/EC (for new vehicle models from 29/04/2009) and should also be observed in countries in which there are no special regulations.

Important

Failure to follow the installation instructions will result in the invalidation of the type approval for the heater and therefore invalidation of the general **homologation of the vehicle**.

Note

The heater is licensed in accordance with paragraph 19, section 3, No. 2b of the StVZO (German Road Traffic Licensing Authority).

2.1 Excerpt from ECE regulation 122 (heating system) paragraph 5 for the installation of the heater

Beginning of excerpt.

ANNEX VII

REQUIREMENTS FOR COMBUSTION HEATERS AND THEIR INSTALLATION

1. GENERAL REQUIREMENTS

1.7.1. A clearly visible tell-tale in the operator's field of view shall inform when the combustion heater is switched on or off.

2. VEHICLE INSTALLATION REQUIREMENTS

2.1. Scope

2.1.1. Subject to paragraph 2.1.2, combustion heaters shall be installed according to the requirements of this Annex.

2.1.2. Vehicles of category O having liquid fuel heaters are deemed to comply with the requirements of this Annex.

2.2. Positioning of heater

2.2.1. Body sections and any other components in the vicinity of the heater must be protected from excessive heat and the possibility of fuel or oil contamination.

2.2.2. The combustion heater shall not constitute a risk of fire, even in the case of overheating. This requirement shall be deemed to be fulfilled if the installation ensures an adequate distance to all parts and suitable ventilation, by the use of fire resistant materials or by the use of heat shields.

2.2.3. In the case of M2 and M3 vehicles, the heater must not be positioned in the passenger compartment. However, an installation in an effectively sealed envelope which also complies with the conditions in paragraph 2.2.2 may be used.

2.2.4. The label referred to in paragraph 1.4 or a duplicate, must be positioned so that it can be easily read when the heater is installed in the vehicle.

2.2.5. Every reasonable precaution should be taken in positioning the heater to minimise the risk of injury and damage to personal property.

2.3. Fuel supply

2.3.1. The fuel filler must not be situated in the passenger compartment and must be provided with an effective cap to prevent fuel spillage.

2.3.2. In the case of liquid fuel heaters, where a supply separate to that of the vehicle is provided, the type of fuel and its filler point must be clearly labelled.

2.3.3. A notice, indicating that the heater must be shut down before refuelling, must be affixed to the fuelling point. In addition a suitable instruction must be included in the manufacturer's operating manual.

2.4. Exhaust system

2.4.1. The exhaust outlet must be located so as to prevent emissions from entering the vehicle through ventilators, heated air inlets or opening windows.

2.5. Combustion air inlet

2.5.1. The air for the combustion chamber of the heater must not be drawn from the passenger compartment of the vehicle.

2.5.2. The air inlet must be so positioned or guarded that blocking by rubbish or luggage is unlikely.

2.6. Heating air inlet

2.6.1. The heating air supply may be fresh or recirculated air and must be drawn from a clean area not likely to be contaminated by exhaust fumes emitted either by the propulsion engine, the combustion heater or any other vehicle source.

2.6.2. The inlet duct must be protected by mesh or other suitable means.

2.7. Heating air outlet

2.7.1. Any ducting used to route the hot air through the vehicle must be so positioned or protected that no injury or damage could be caused if it were to be touched.

2.7.2. The air outlet must be so positioned or guarded that blocking by rubbish or luggage is unlikely.

End of excerpt.

In multilingual versions the German language is binding.

Suzuki Vitara

Information on Validity

This installation documentation applies to Suzuki Vitara Diesel vehicles - for validity, see page 1 - from model year 2015 and later, assuming technical modifications to the vehicle do not affect installation, any liability claims excluded. Depending on the vehicle version and equipment, modifications may be necessary during installation with respect to this 'installation documentation'.

Vehicle and engine types, equipment variants and other specifications not listed in this installation documentation have not been tested. However, installation according to this installation documentation may be possible.

Technical Information

Special Tools

- Hose clamp pliers for auto-tightening hose clamps
- Hose clamp pliers for Clic hose clamps of type W
- Automatic wire stripper 0.2 - 6 mm²
- Crimping pliers for cable lug / tab connector 0.5 - 6 mm²
- Torque wrench for 2.0 - 10 Nm
- Hose clamping pliers
- Metric thread-setter kit
- Deep-hole marker
- Webasto Thermo Test Diagnosis with current software

Dimensions

- All dimensions are in mm.

Tightening torque values

- Tightening torque values of 5x13 heater bolts and 5x11 heater stud bolts = 8Nm.
- Tightening torque value of 5x15 water connection piece retaining plate bolt = 7Nm.
- Tighten other bolt connections in accordance with manufacturer's instructions or in accordance with state-of-the-art technology.

Explanatory Notes on Document

You will find an identification mark on the outside top right corner of the page in question to provide you with a quick overview of the individual working steps.

Special features are highlighted using the following symbols:

Mechanical System



Electrical System



Coolant Circuit



Combustion Air



Fuel



Exhaust Gas



Software



Specific risk of damage to components.



Specific risk due to electrical voltage.



Specific risk of injury or fatal accidents.



Specific risk of fire or explosion.



Reference to the manufacturer's vehicle-specific documents or to the general installation instructions of Webasto components.



Reference to a special technical feature.



The arrow in the vehicle icon indicates the position on the vehicle and the viewing angle.

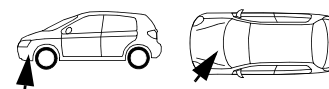

Tightening torque according to the manufacturer's vehicle-specific documents.



Preliminary Work

Vehicle



- Open the fuel tank cap.
- Ventilate the fuel tank.
- Close the fuel tank cap again.
- Depressurise the cooling system.
- Disconnect and completely remove the battery together with the carrier.
- Remove the left and right front wheels.
- Remove the left and right wheel well trims.
- Remove the engine underride protection.
- Detach the underride protection on the right-hand side.
- Remove the bumper.
- Remove the instrument panel decorative trim piece on the right (only in case of automatic air-conditioning).
- Remove the radio / navigation system.
- Remove the A/C control panel.
- Remove the AC booster.
- Remove the lower instrument panel trim on the driver's side.
- Remove the footwell trim on the driver's and front passenger's sides.

The following work should only be performed during the corresponding installation sequence:



- Remove the exhaust tube under the vehicle.
- Loosen the Cardan shaft (4 WD only).
- Remove the fuel tank in accordance with the manufacturer's instructions.

Heater

- Remove years that do not apply from the type and duplicate label.
- Attach the duplicate label (type label) visibly in the appropriate place in the engine compartment.

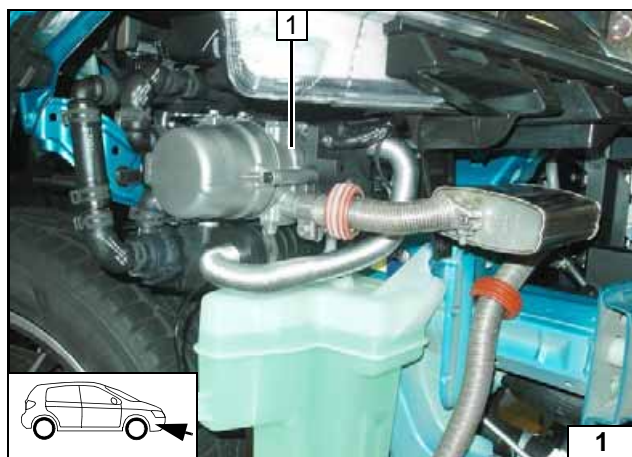

Heater Installation Location

- 1 Heater



Installation location

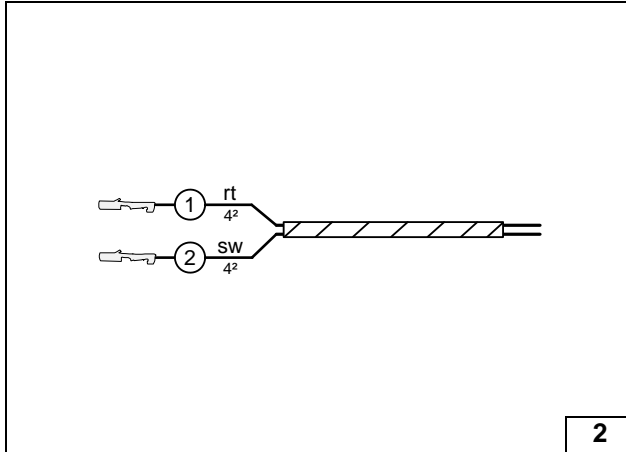

Preparing Electrical System

Wire sections retain their numbering in the entire document.

Produce all following electrical connections as shown in the wiring diagram.

Manual air-conditioning

- ① Red (rt) wire of fan wiring harness
- ② Black (sw) wire of fan wiring harness



Assigning wires

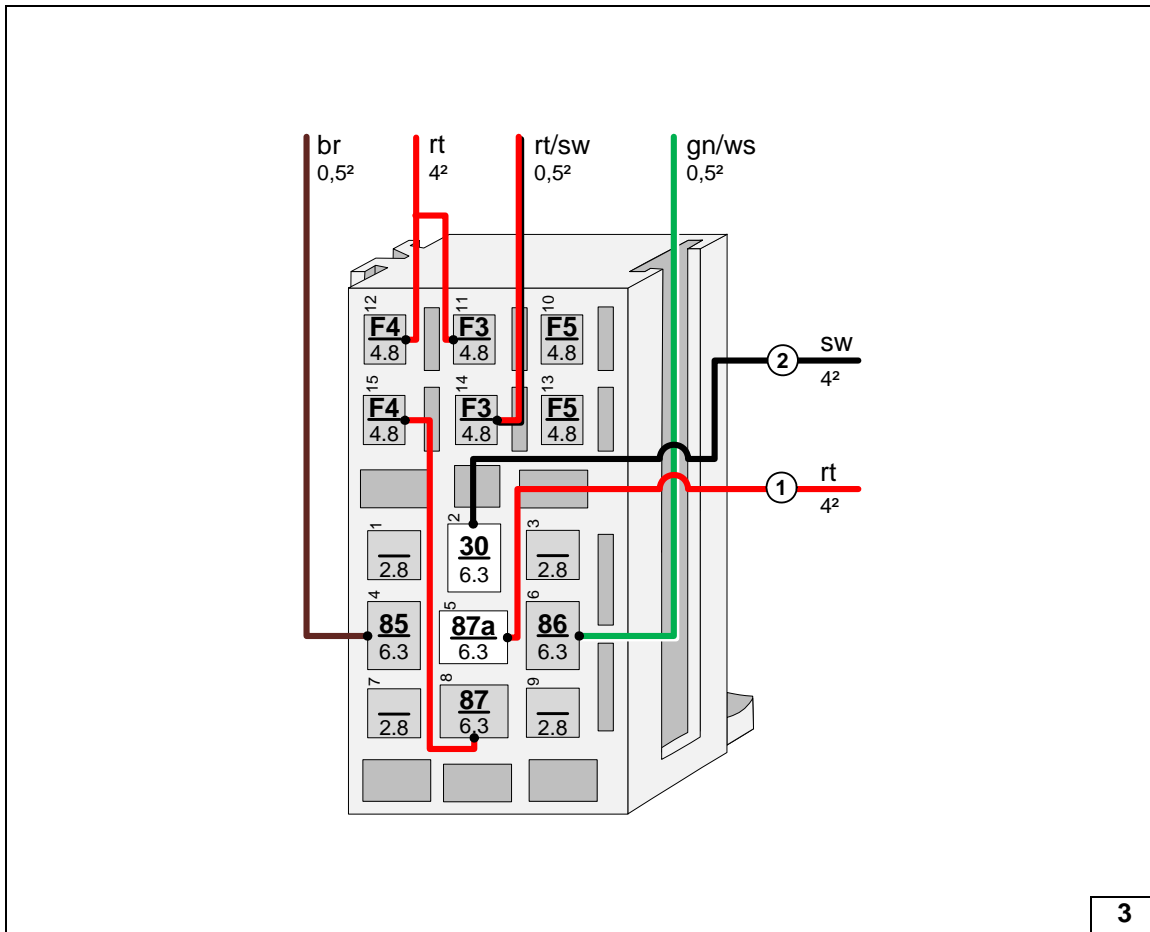

Connecting wires to passenger compartment relay and fuse holder

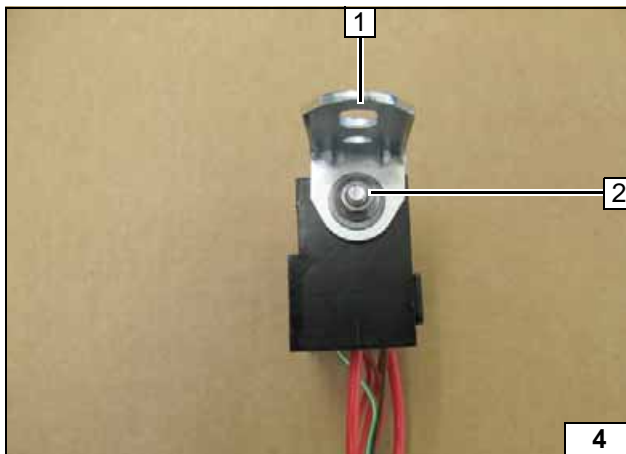

- 1 Angle bracket
- 2 M5x16 bolt, large diameter washer [2x], nut

Premounting passenger compartment relay and fuse holder

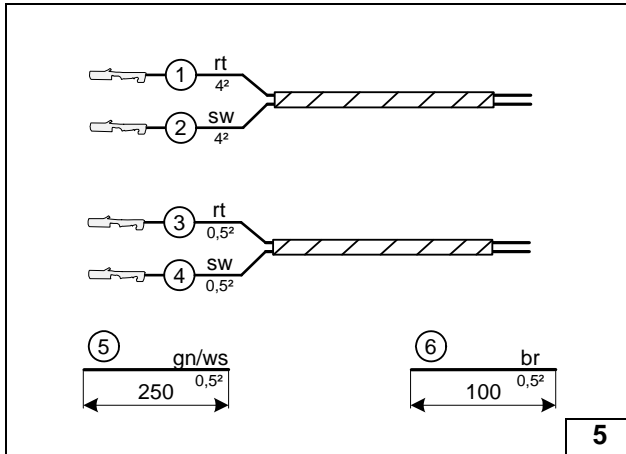

Automatic air-conditioning

- ① Red (rt) wire of fan wiring harness
- ② Black (sw) wire of fan wiring harness
- ③ Red (rt) wire from wiring harness of PWM control
- ④ Black (sw) wire from wiring harness of PWM control

Assigning wires

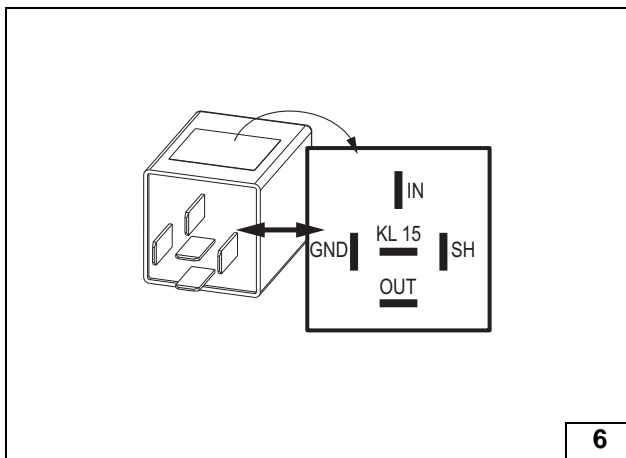

Check the PWM Gateway settings when starting up the heater and adjust if necessary.

Settings:

- Duty cycle: 100% (DC)
- Frequency: not relevant
- Voltage: 3.9V
- Function: High side

View of PWM GW

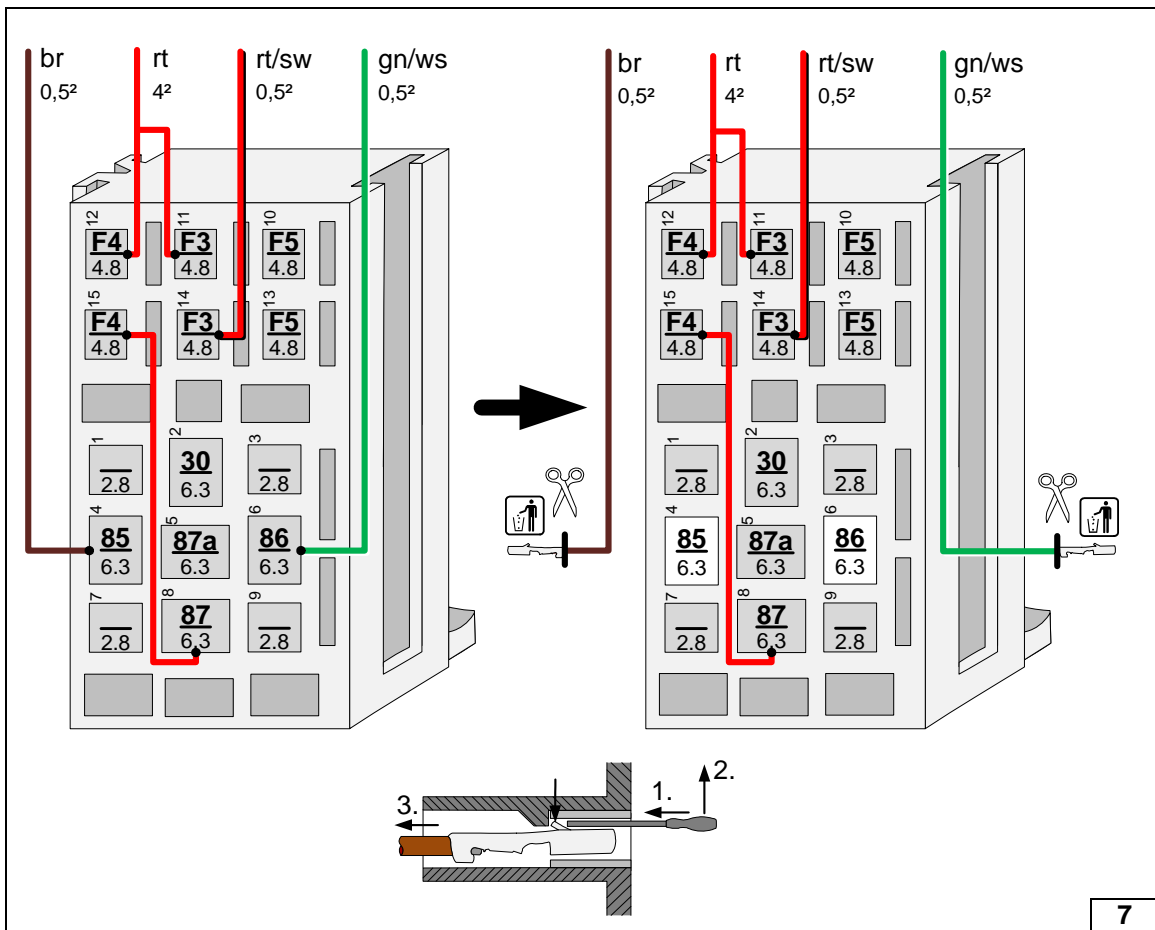

Preparing passenger compartment relay and fuse holder

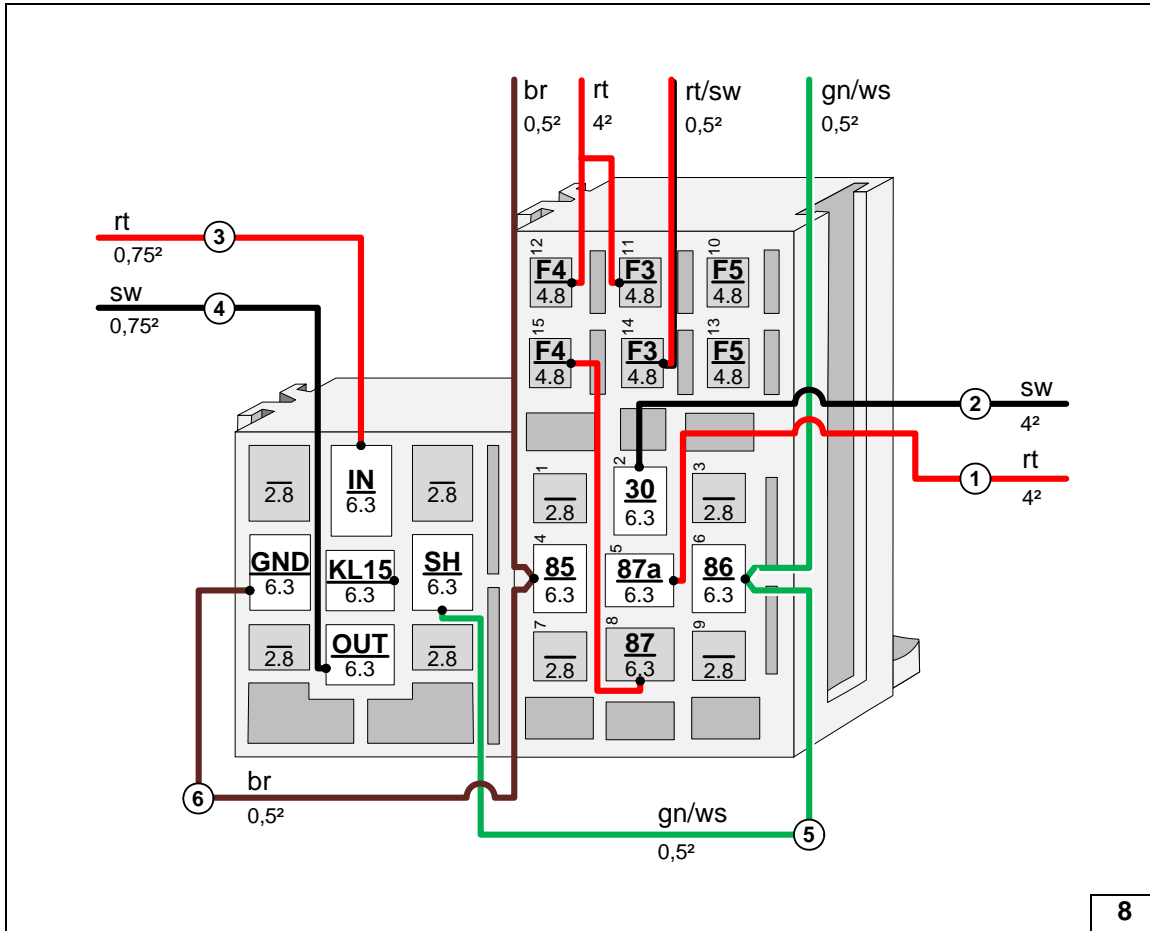

Interlocking PWM GW socket and passenger compartment relay and fuse holder, connecting wires

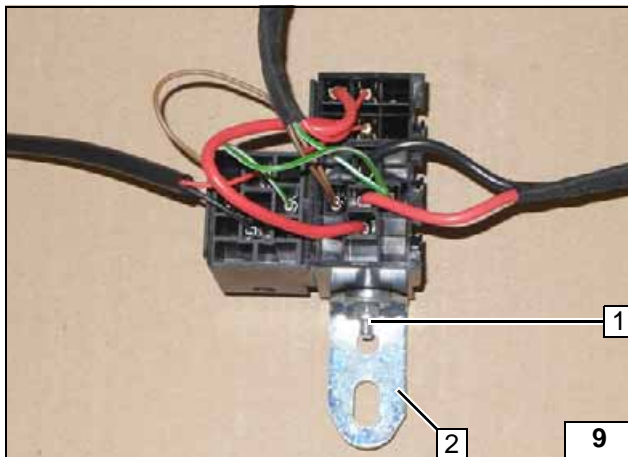

- 1 M5x16 bolt, large diameter washer [2x], nut
- 2 Angle bracket

Premounting passenger compartment relay and fuse holder



Electrical System



Positive wire

- 1 Positive wire on positive battery distributor

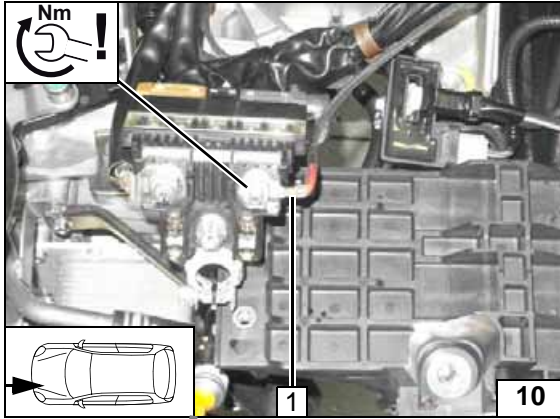

Wiring harness routing

- 1 Protective rubber plug
- 2 Wiring harnesses of heater and heater control

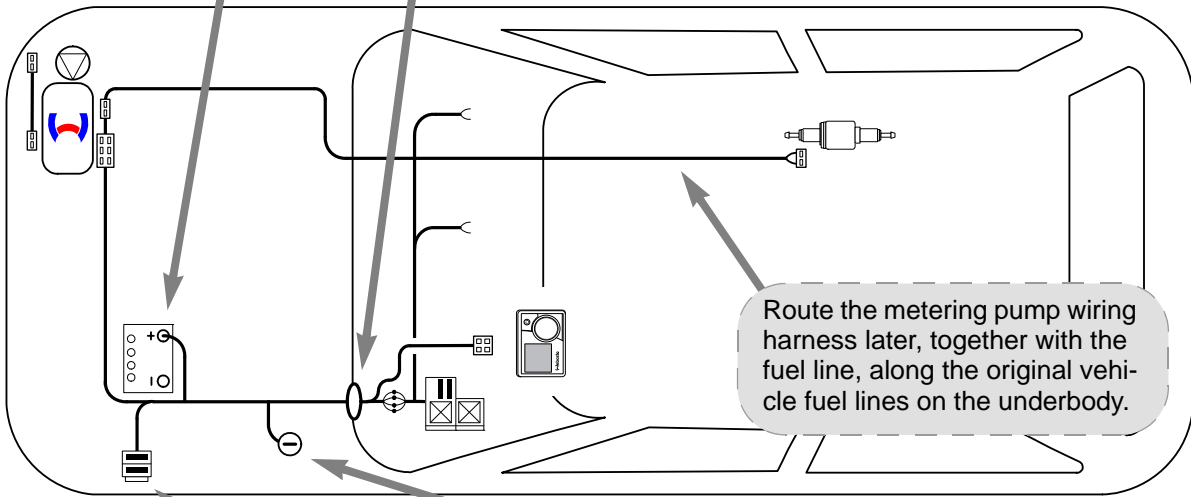
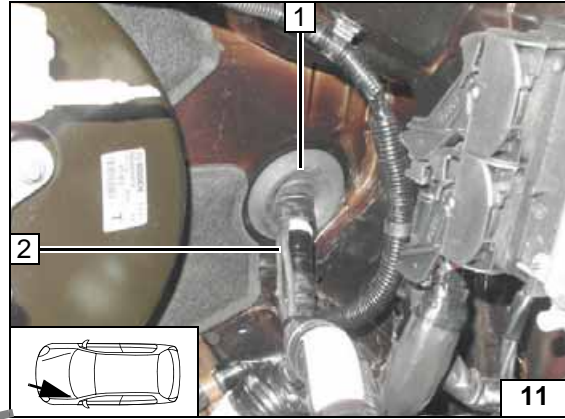

Wiring harness routing diagram

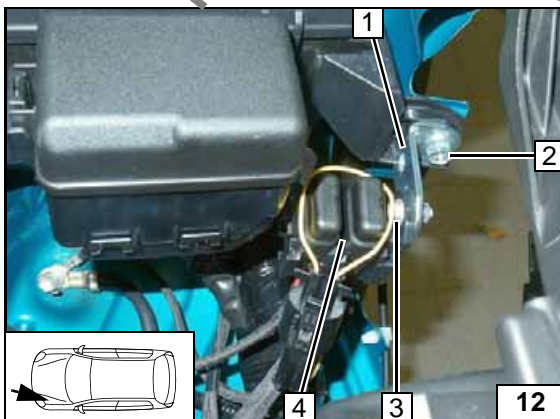

Engine compartment fuse holder

- 1 Angle bracket
- 2 Original vehicle bolt
- 3 M5x16 bolt, large diameter washer [2x], retaining plate of fuse holder, nut
- 4 Fuses F1-2

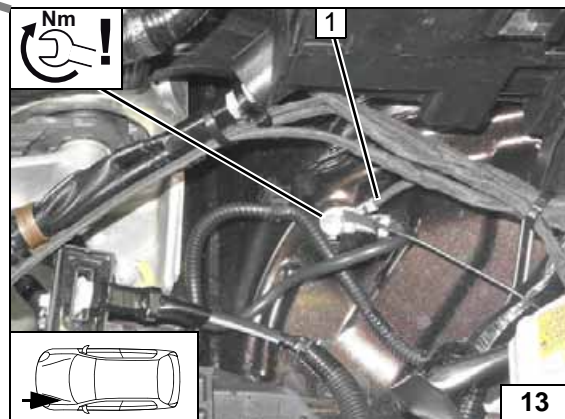

Earth wire

- 1 Earth wire on original vehicle earth support point



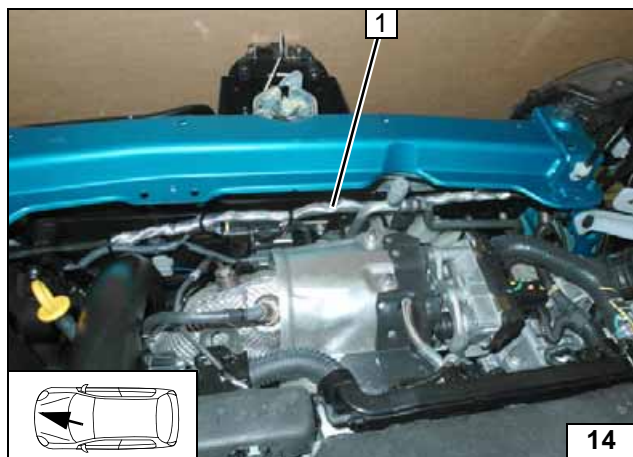
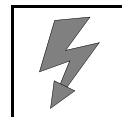

Wiring harness routing

Split heat protection hose **1** open lengthwise and pull over heater wiring harness. Fasten to original vehicle wiring harness using cable ties.



Wiring harness routing in the engine compartment



Manual Air-Conditioning Fan Controller



Wiring diagram

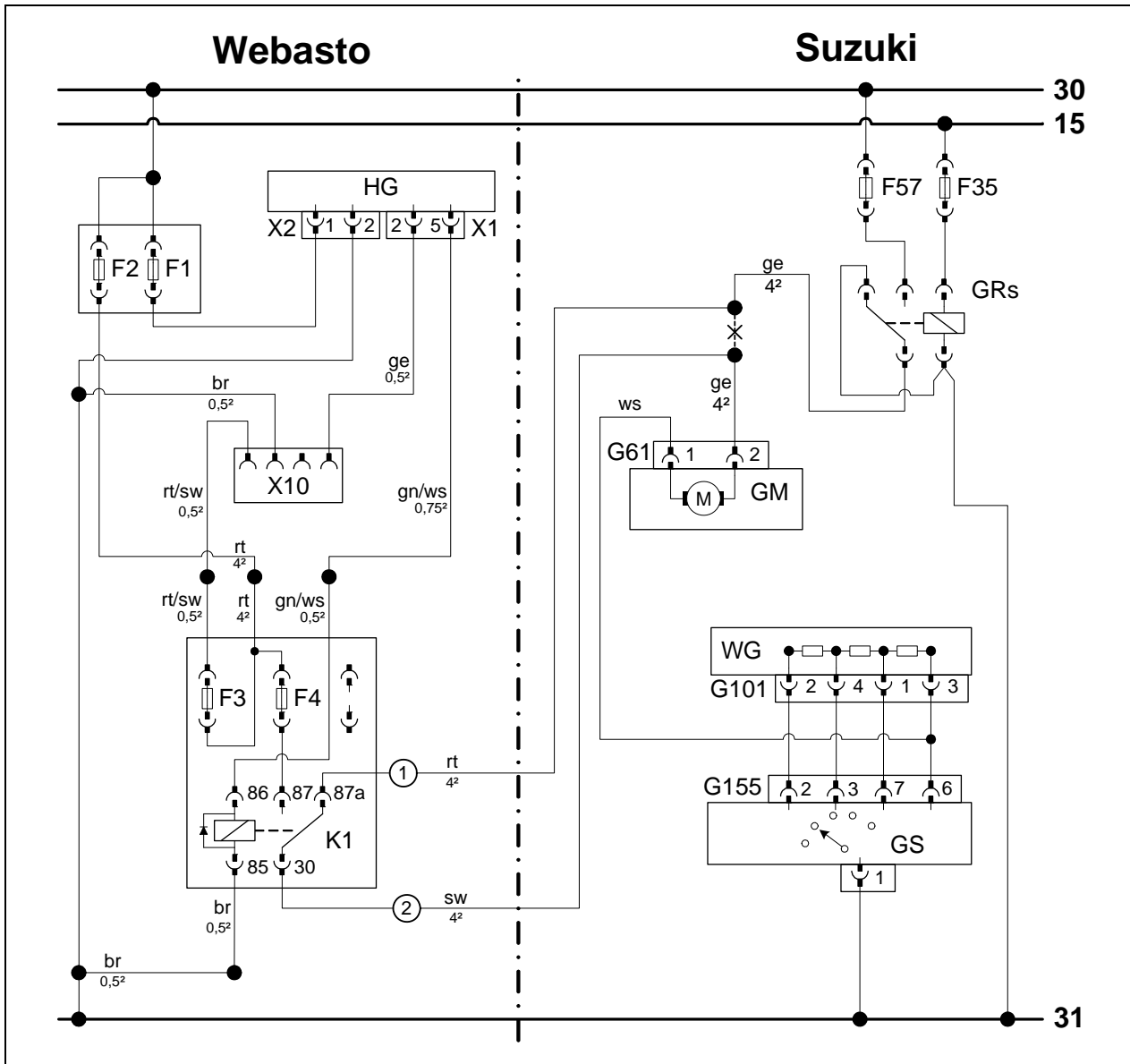

Webasto components		Vehicle components		Colours and symbols	
HG	TT-Evo heater	F57	30A fuse	rt	red
X1	6-pin heater connector	F35	7.5A fuse	sw	black
X2	2-pin heater connector	GRs	Fan relay	ge	yellow
F1	20A fuse	G61	Fan motor	gn	green
F2	30A fuse	WG	Resistor group	ws	white
X10	4-pin connector of heater control	G101	4-pin connector of WG	br	brown
K1	Fan relay	GS	Fan switch		
F3	1A fuse	G155	Connector of GS		
F4	25A fuse			X	Cutting point
				Wiring colours may vary.	

Legend

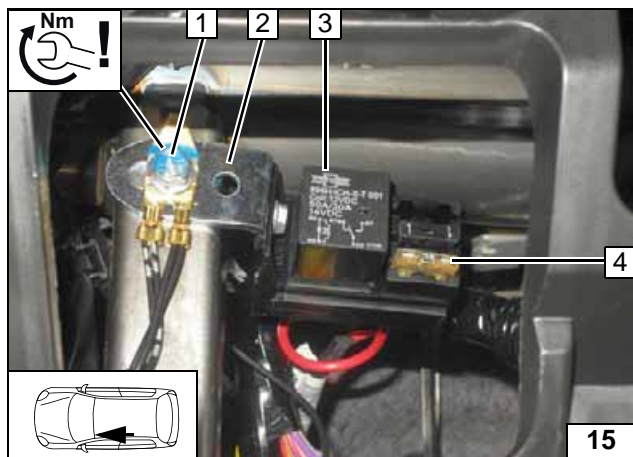

- 1 Original vehicle bolt earth point
- 2 Angle bracket
- 3 Relay K1
- 4 25A fuse F4



Installing passenger compartment relay and fuse holder

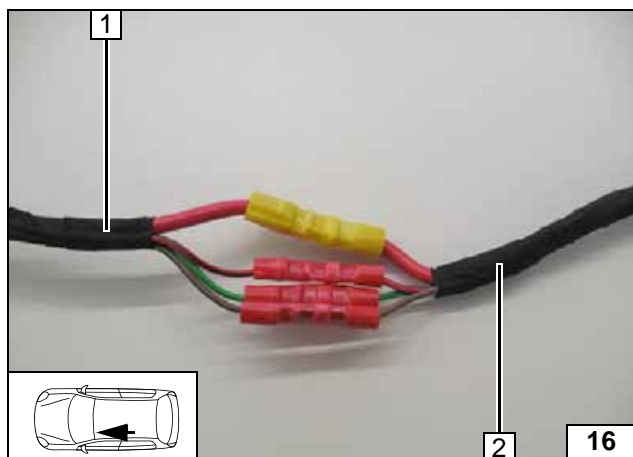

- 1 Passenger compartment relay and fuse holder wiring harness
- 2 Heater wiring harness

Connecting same colour wires of wiring harnesses

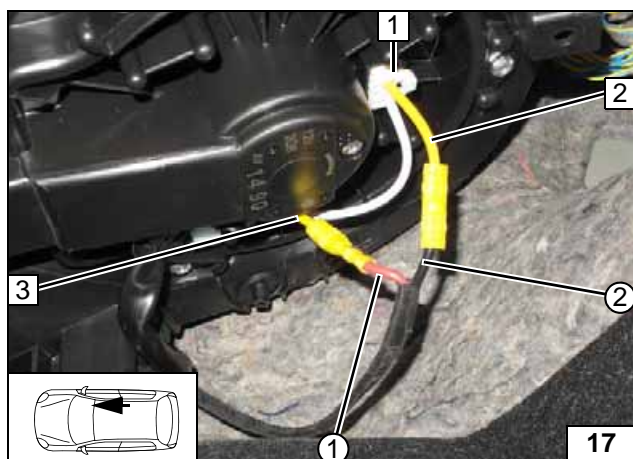

- 1 2-pin connector G61/2 of fan motor
- 2 Yellow (ge) wire of 2-pin GM connector
- 3 Yellow (ge) wire of fan relay
- ① Red (rt) wire of K1/87a, fan wiring harness
- ② Black (sw) wire of K1/30, fan wiring harness

Connecting fan motor

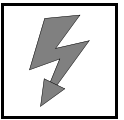

Automatic Air-Conditioning Fan Controller

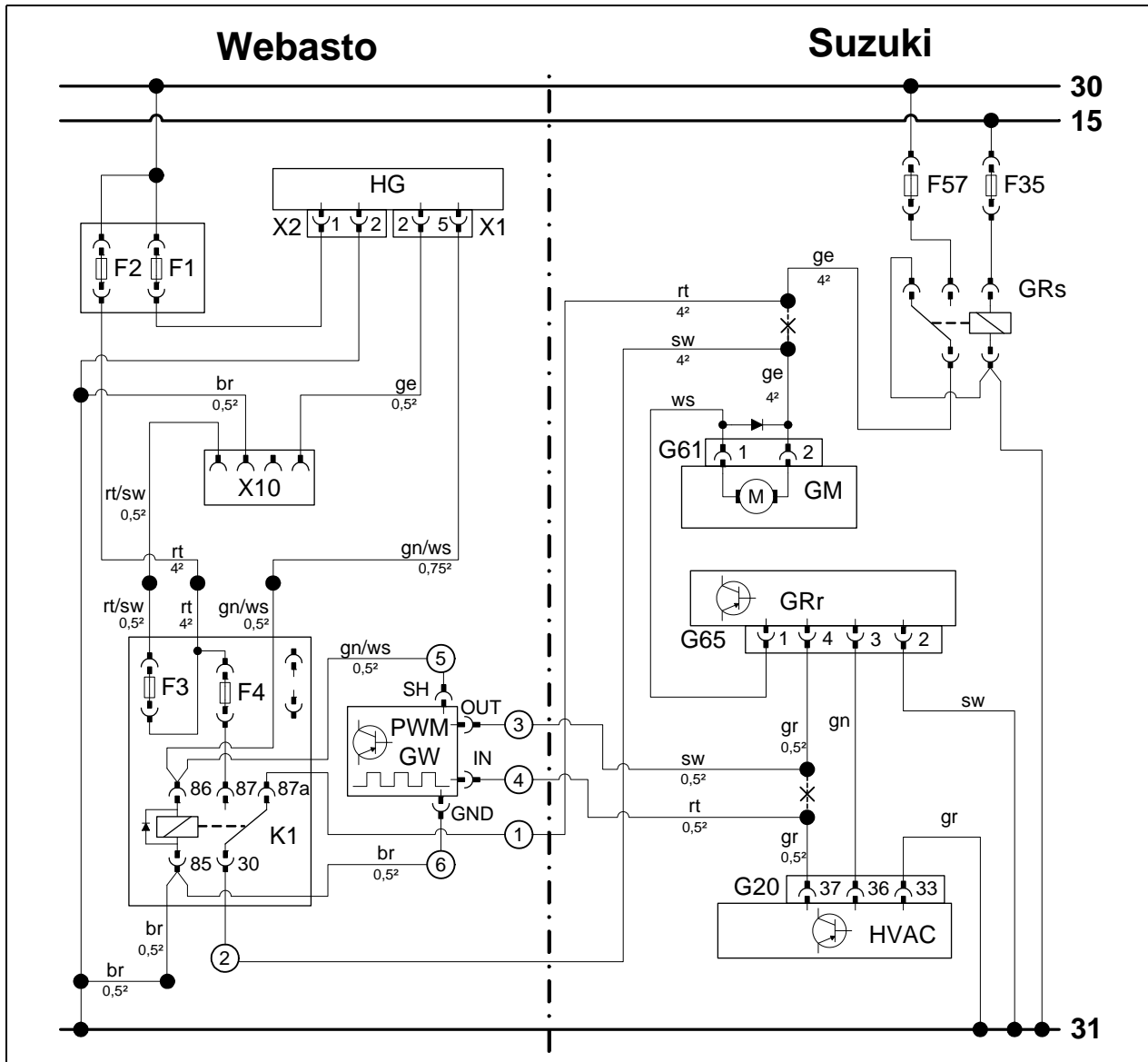

Wiring diagram

Webasto components		Vehicle components		Colours and symbols	
HG	TT-Evo heater	F57	30A fuse	rt	red
X1	6-pin heater connector	F35	7.5A fuse	sw	black
X2	2-pin heater connector	GRs	Fan relay	ge	yellow
F1	20A fuse	GM	Fan motor	gn	green
F2	30A fuse	G61	2-pin connector of GM	gr	grey
X10	4-pin connector of heater control	GRr	Fan controller	ws	white
F3	1A fuse	G65	4-pin connector of GRr	br	brown
F4	25A fuse	HVAC	AC booster		
PWM-GW	Pulse width modulator	G20	40-pin connector of HVAC		
K1	Fan relay				
PWM GW settings:					
Duty cycle: 100% (DC)					
Frequency: not relevant					
Voltage: 3.9V					
Function: High side					
				X	Cutting point
Wiring colours may vary.					

Legend

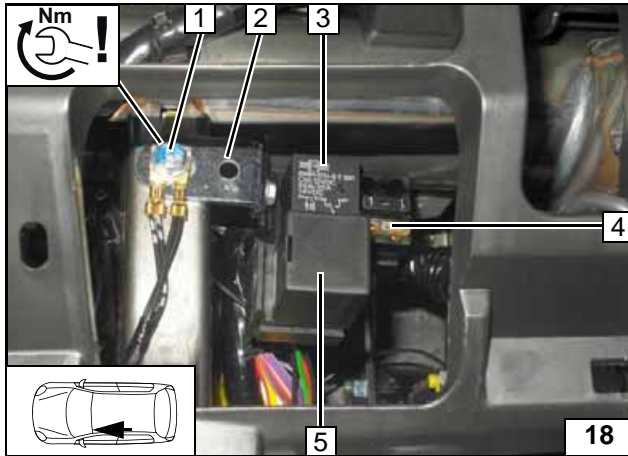

- 1 Original vehicle bolt earth point
- 2 Angle bracket
- 3 Relay K1
- 4 25A fuse F4
- 5 PWM Gateway



Installing passenger compartment relay and fuse holder

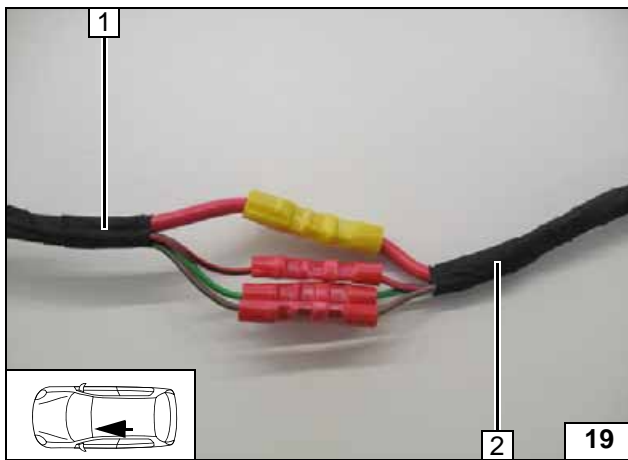

- 1 Passenger compartment relay and fuse holder wiring harness
- 2 Heater wiring harness

Connecting same colour wires of wiring harnesses

HVAC Installation Aid

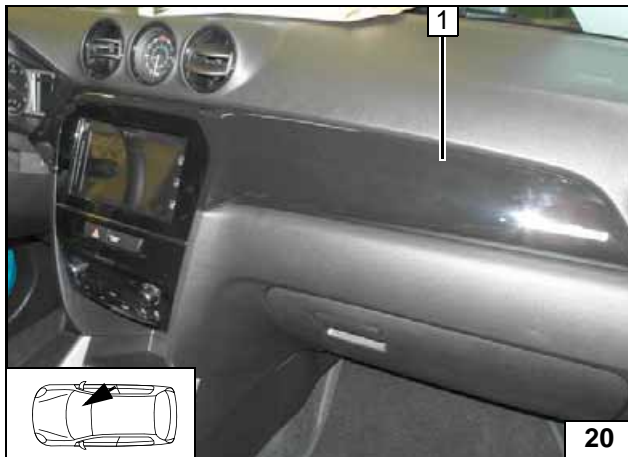

- 1 Trim piece

Unclipping trim piece

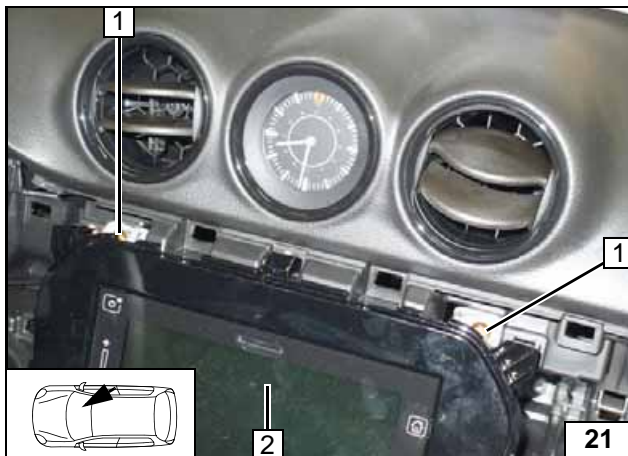

- 1 Original vehicle bolt [2x]
- 2 Touchscreen

Removing Touchscreen screw fitting

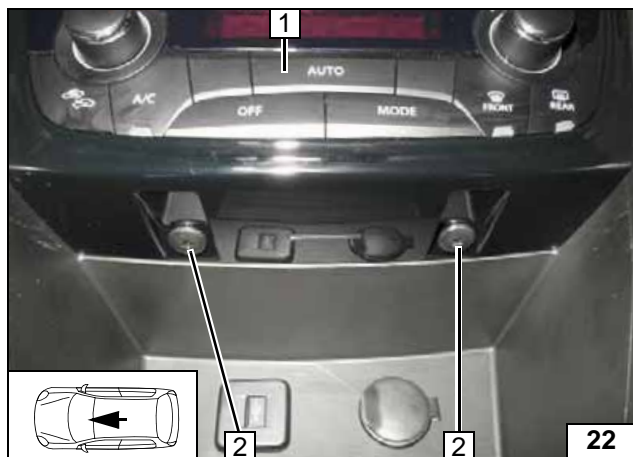

- 1 A/C control panel
- 2 Plastic plug [2x]

Removing A/C control panel



Lift the Touchscreen, unclip the A/C control panel in the direction of the arrow.



Removing A/C control panel

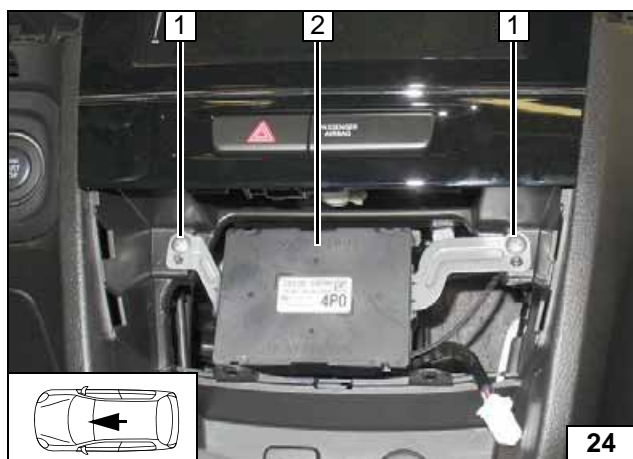

- 1 Bolts [2x]
- 2 HVAC

Removing HVAC

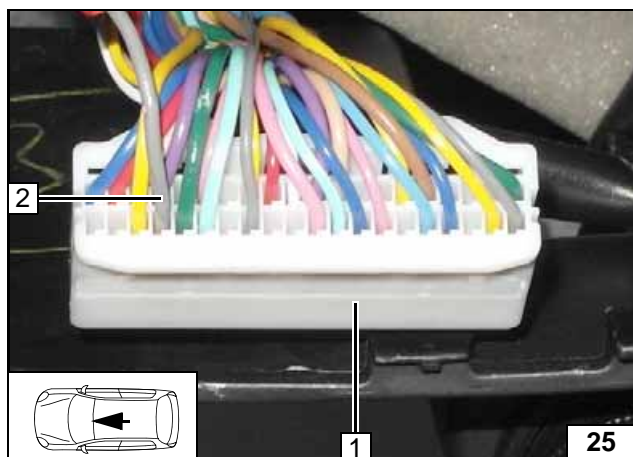

Connecting HVAC and GM

- 1 40-pin G20 connector for AC booster (HVAC)
- 2 Grey (gr) wire, pin 37

View of connector G20

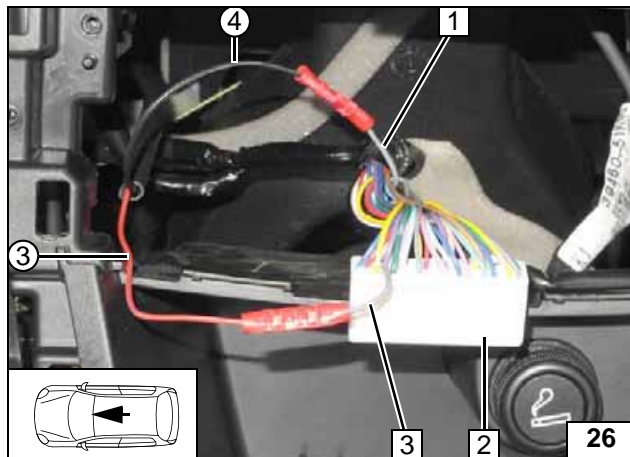
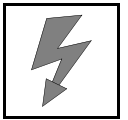

- 1 Grey (gr) wire of fan controller
- 2 40-pin G20 connector for AC booster (HVAC)
- 3 Grey (gr) wire of G20, pin 37
- ③ Red (rt) wire from PWM Gateway / IN of wiring harness of PWM control
- ④ Black (sw) wire from PWM Gateway / OUT of wiring harness of PWM control

**Connect-
ing A/C
control unit**

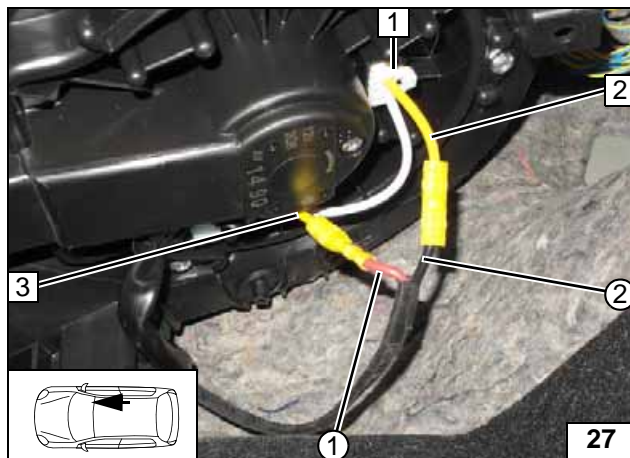

- 1 2-pin connector G61/2 of fan motor
- 2 Yellow (ge) wire of 2-pin GM connector
- 3 Yellow (ge) wire of fan relay
- ① Red (rt) wire of K1/87a, fan wiring harness
- ② Black (sw) wire of K1/30, fan wiring harness

**Connect-
ing fan mo-
tor**

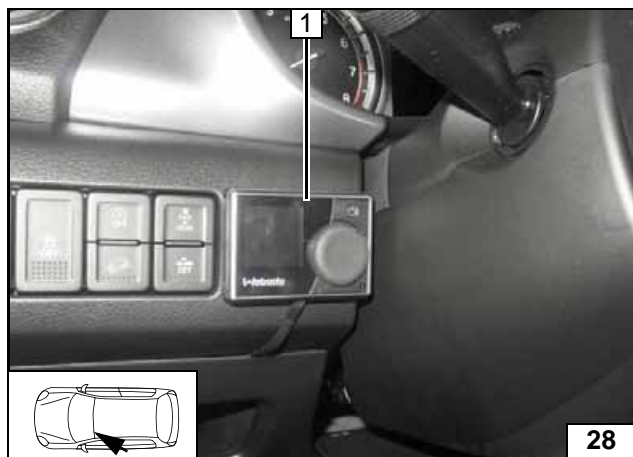

MultiControl CAR Option

- 1 MultiControl CAR



Installing
MultiControl
CAR

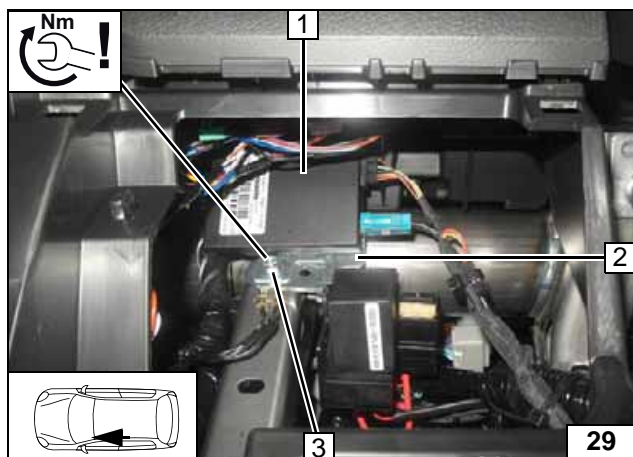

Remote Option (Telestart)

- 1 Receiver
- 2 Telestart bracket
- 3 Original vehicle bolt earth point



Installing
receiver

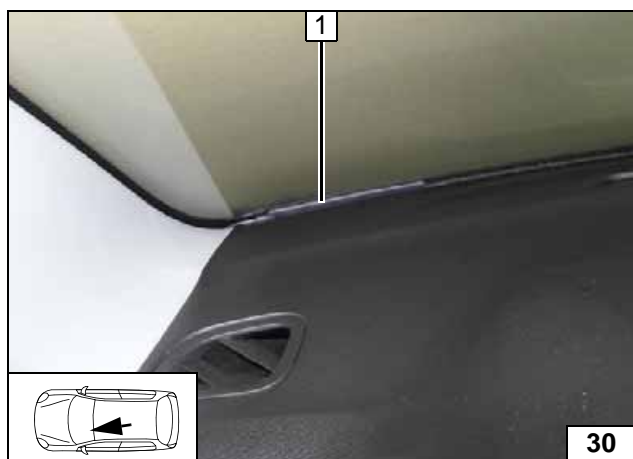

- 1 Aerial

Installing
aerial

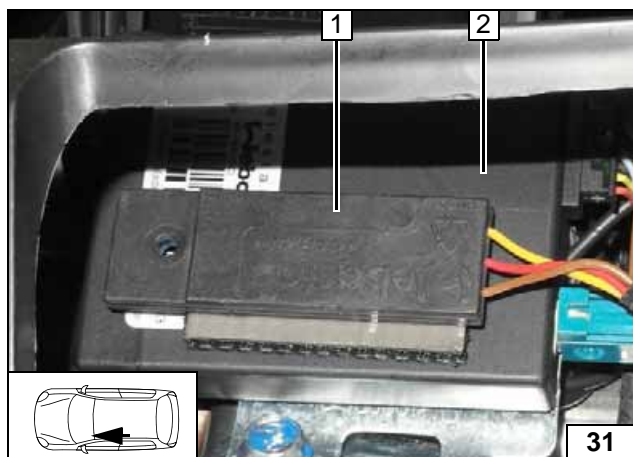

Temperature sensor T100 HTM

Fasten temperature sensor 1 with double-sided adhesive tape.

- 2 Telestart receiver



Installing
temperature
sensor

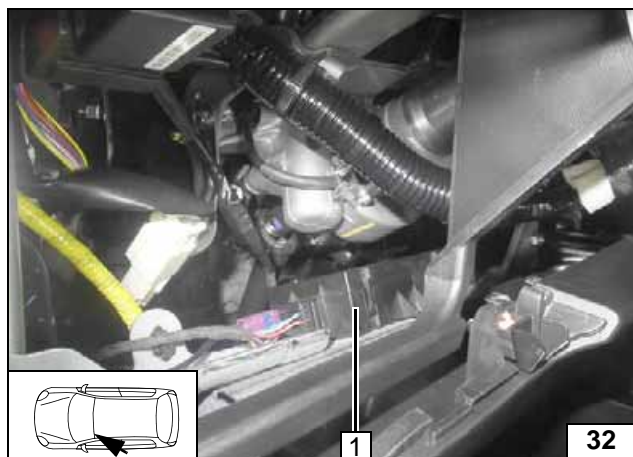
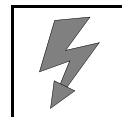

ThermoCall Option

Fasten receiver 1 with double-sided adhesive tape.



Installing receiver

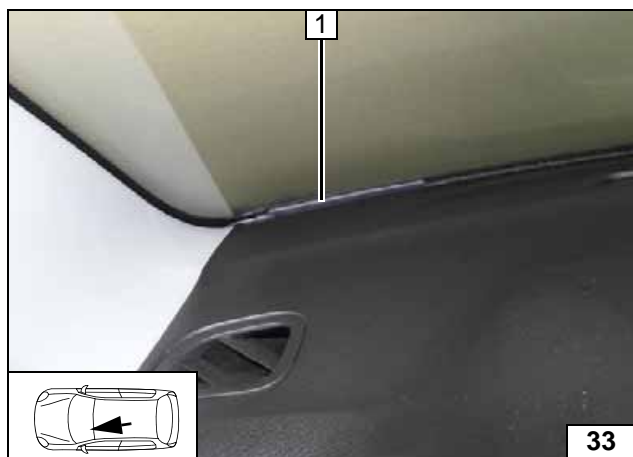

1 Aerial (optional)

Installing aerial

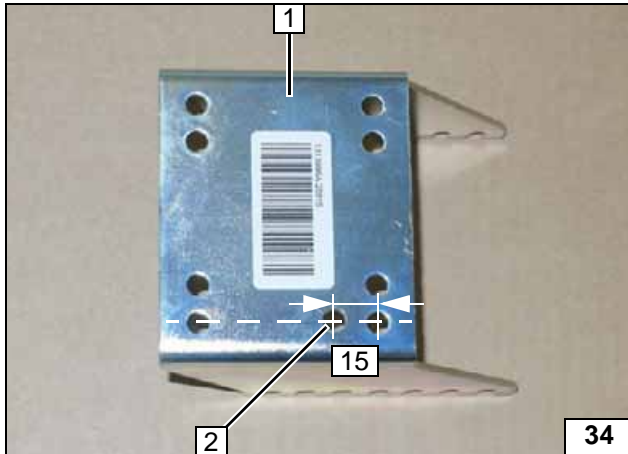
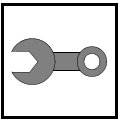

Preparing Installation Location

- 1 Bracket
- 2 7 mm dia. hole

Preparing bracket

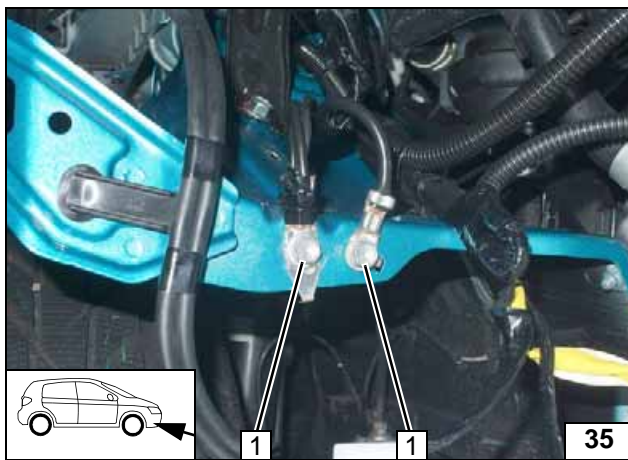

- 1 Original vehicle earth point [2x]

Detaching earth point

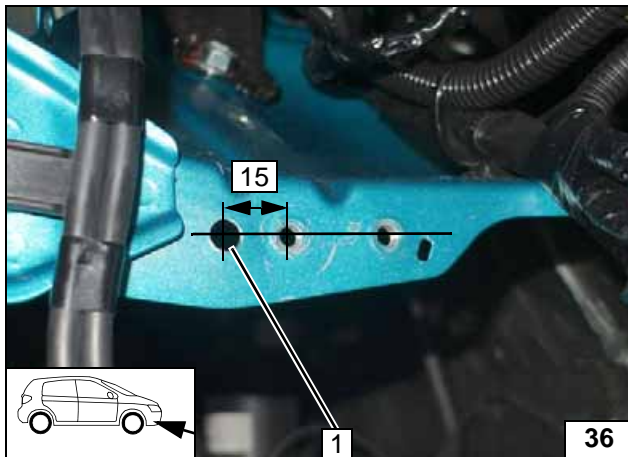

- 1 Hole pattern, 7mm dia. hole

Drilling hole

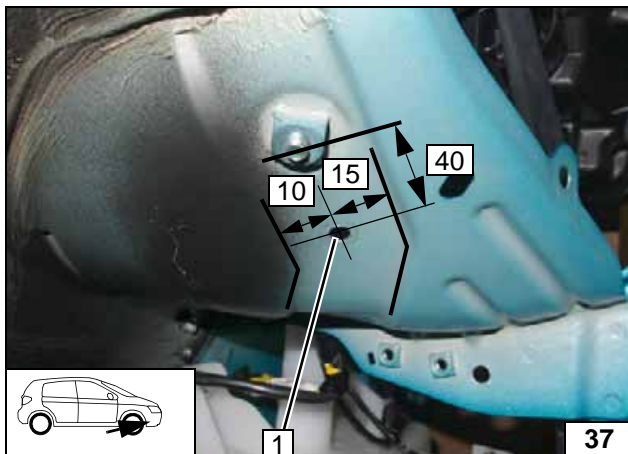

- 1 Hole pattern, 7mm dia. hole

Drilling hole

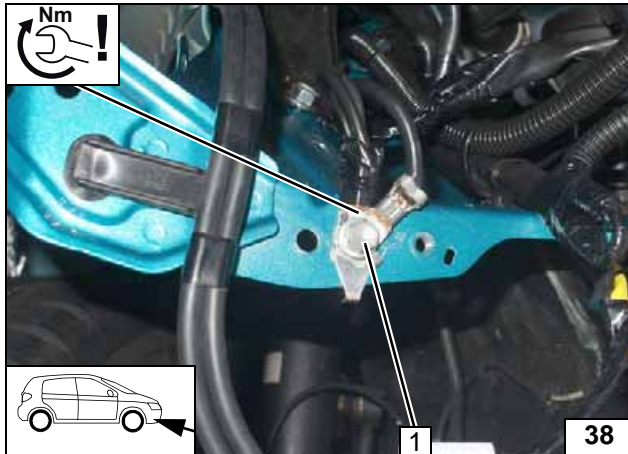
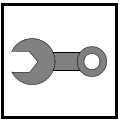

Install original vehicle earth point [2x] at position 1 using original vehicle bolts.



Installing earth point

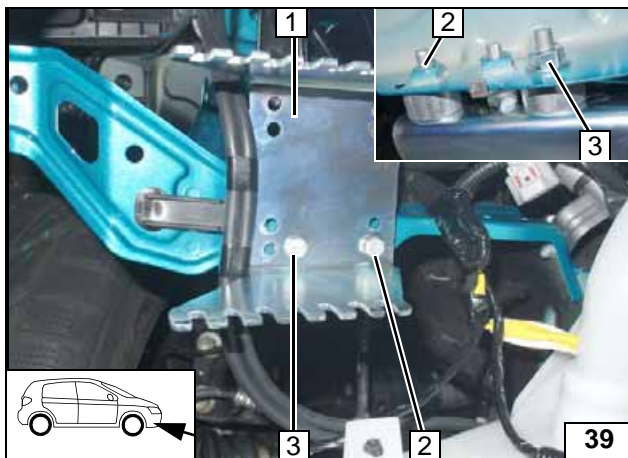

- 1 Bracket
- 2 M6x25 bolt, spring lockwasher, 10mm shim
- 3 M6x25 bolt, 10 shim, M6 flanged nut

Installing bracket

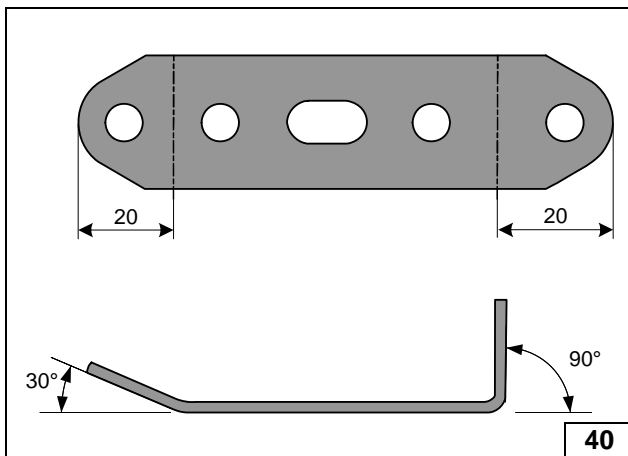

Preparing perforated bracket A

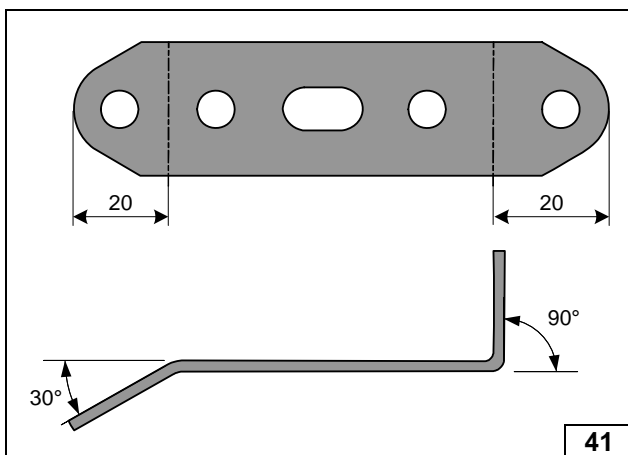

Preparing perforated bracket B

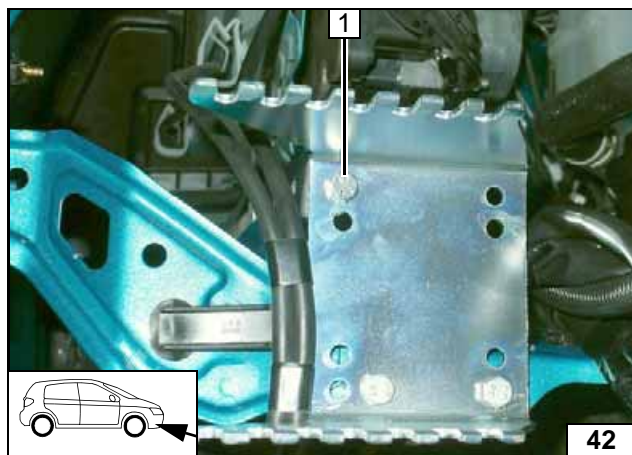

1 M6x20 bolt, large diameter washer, flanged nut

Installing perforated bracket A

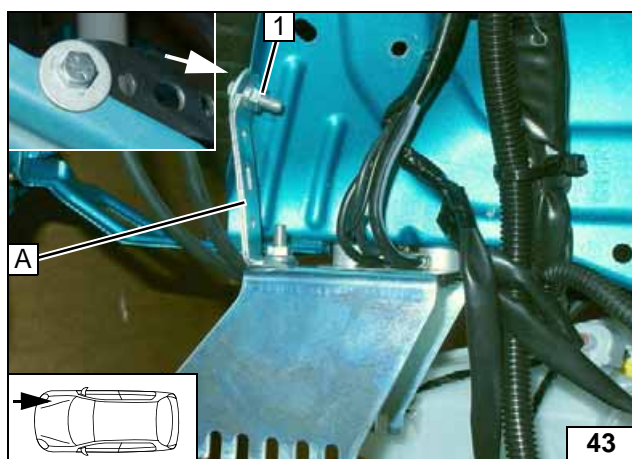

1 M6x20 bolt, large diameter washer, flanged nut

Installing perforated bracket A

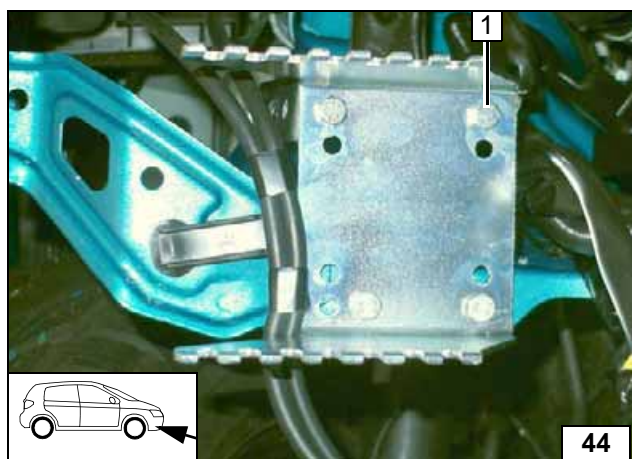

1 M6x20 bolt, flanged nut

Installing perforated bracket B

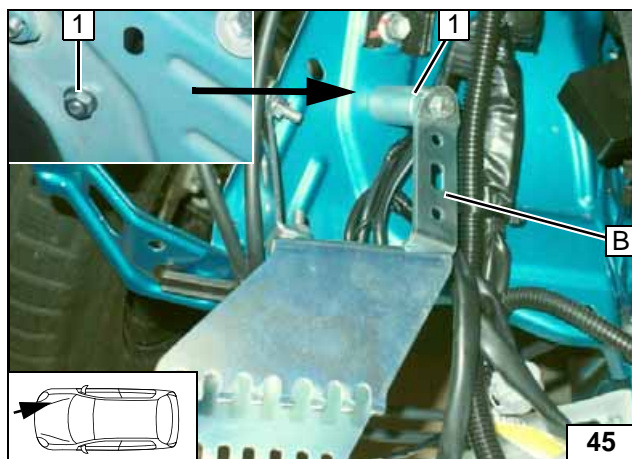

1 M6x60 bolt, 40mm shim, 10mm shim, flanged nut

Installing perforated bracket B

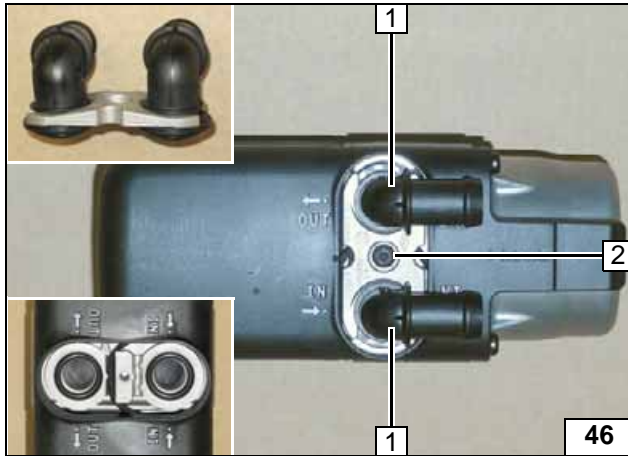
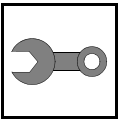

Preparing Heater

- 1 Water connection piece, sealing ring [2x each]
- 2 5x15 self-tapping bolt, retaining plate of water connection piece



Installing water connection piece

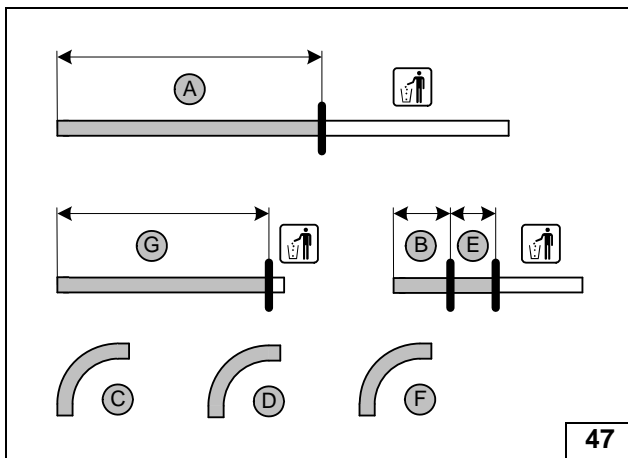

Hoses **B, C, D, E** and **F** = 18mm dia.

- A** = 1360mm, 15mm dia.
- B** = 90mm
- C** = 90°
- D** = 90°
- E** = 60mm
- F** = 90°
- G** = 1170mm, 15mm dia.



Cutting to length / assigning hoses

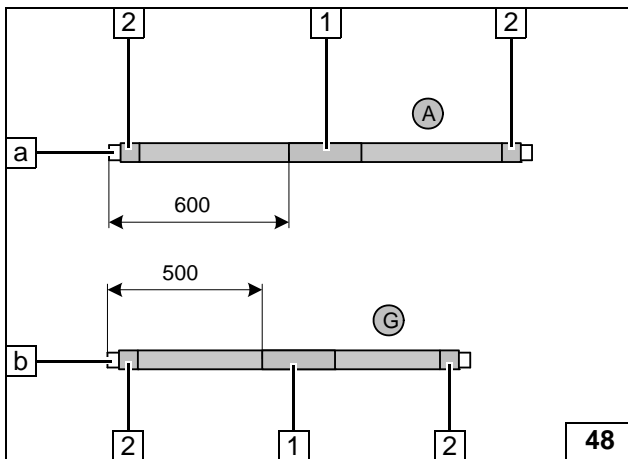

Slide braided protection hoses onto hoses **A** and **G** and cut to length. Cut heat shrink plastic tubing to size.

- 1 250mm long heat shrink plastic tubing [2x]
- 2 60 mm long heat shrink plastic tubing [4x]

- a** Heater inlet side
- b** Heater outlet side



Preparing hoses

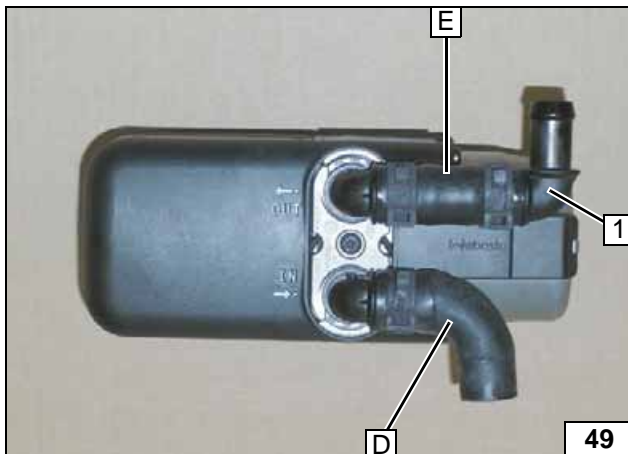

All spring clips = 25 mm dia.

- 1 90° connecting pipe



Premounting hoses D and E

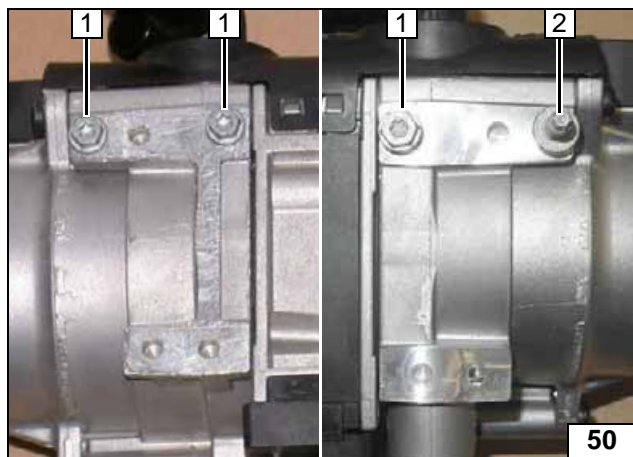

Screw 5x13 self-tapping bolts **1** [3x] and M5 / M6x25,5 stud bolt **2** in existing holes by a maximum of 3 thread turns.

Premounting bolts loosely

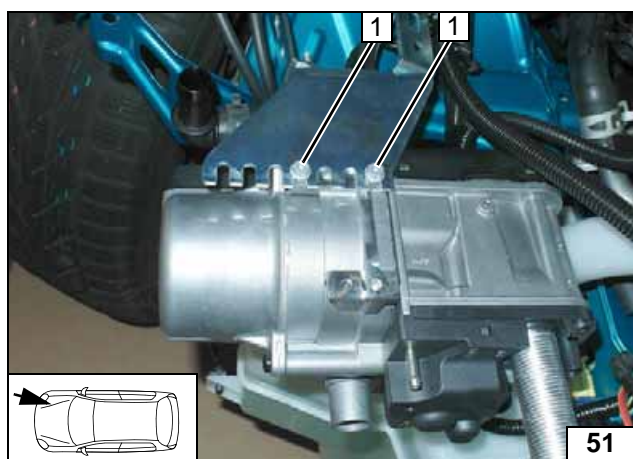

Installing Heater

- 1 Tighten 5x13 self-tapping bolt [2x]

Installing heater

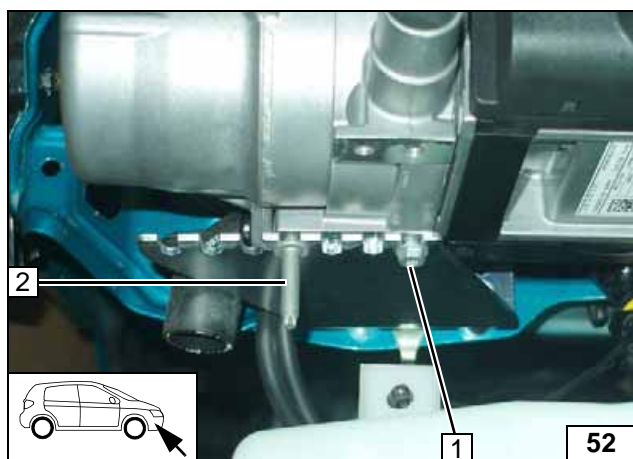

- 1 Tighten 5x13 self-tapping bolt
- 2 Tighten M5/M6x25,5 stud bolt

Installing heater

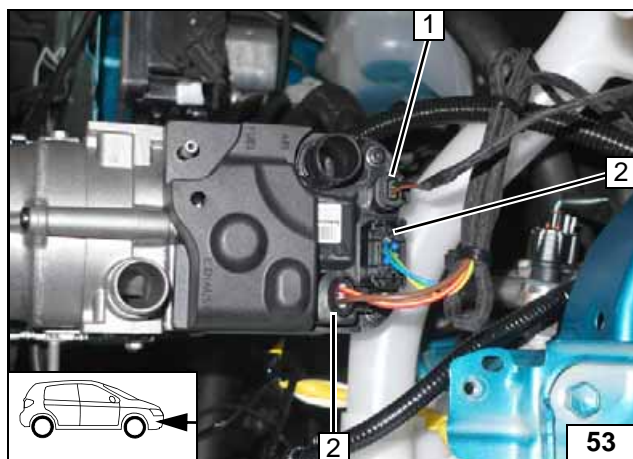

- 1 Circulating pump wiring harness connector
- 2 Heater wiring harness connector [2x]

Installing heater wiring harness

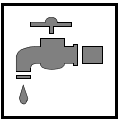

Coolant Circuit



Any coolant running off should be collected in an appropriate container. Route hoses kink-free. Unless specified otherwise, always fasten using cable ties. Position clamps so that other hoses cannot be damaged. The heater must be filled with coolant when installing the hoses.

The connection should be modeled on an 'inline' circuit and based on the following diagram:

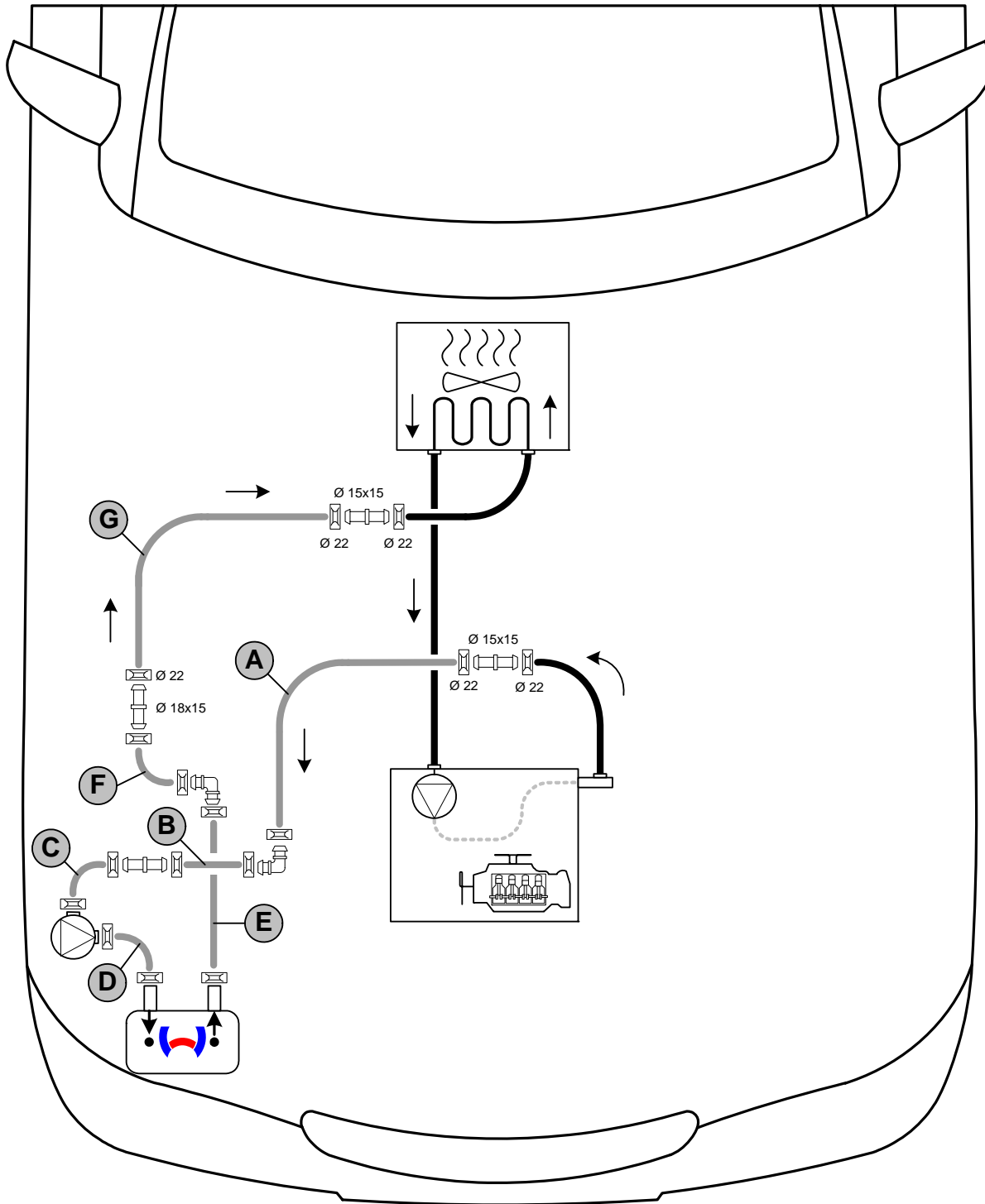

Hose routing diagram

All spring clips without a specific designation  = 25 mm dia.
 All connecting pipes without a specific designation  and  = 18x18 mm dia.



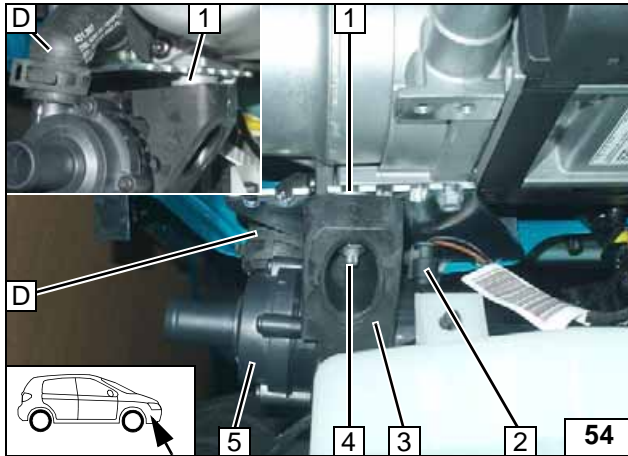

Insert 5mm shim 1 between bracket and circulating pump mount 3.



- 2 Circulating pump wiring harness connector
- 4 M6 flanged nut on stud bolt
- 5 Circulating pump

Installing circulating pump

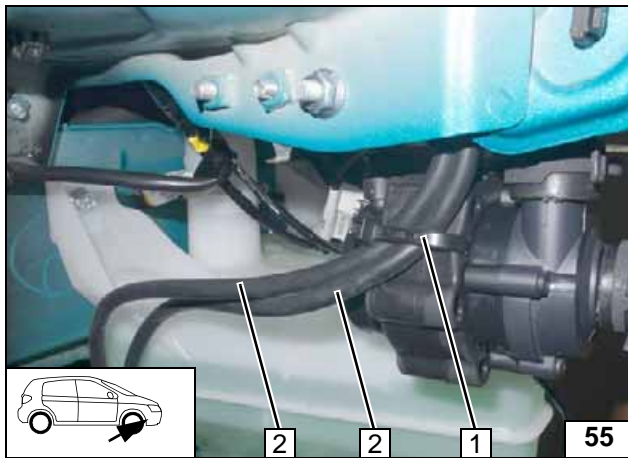

- 1 Cable tie through circulating pump mount
- 2 Windscreen cleaning system hose [2x]

Securing original vehicle windscreen cleaning system hoses



Cut off hose of engine outlet/heat exchanger inlet at the marking.



- 1 Heat exchanger inlet hose section
- 2 Engine outlet hose section

Cutting point

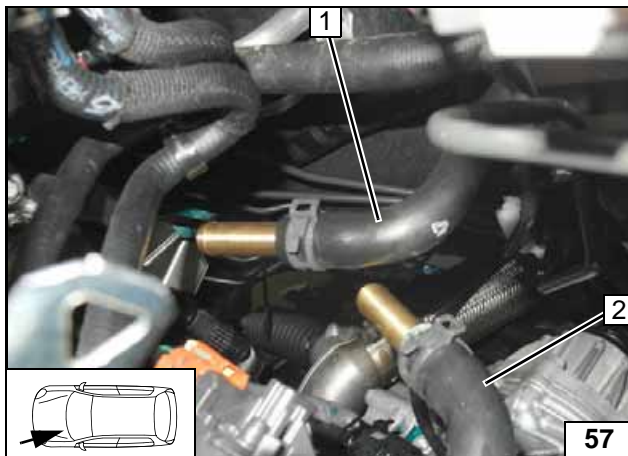

- 1 Hose section of heat exchanger inlet turned by approx. 180°
- 2 Engine outlet hose section

Preparing hoses

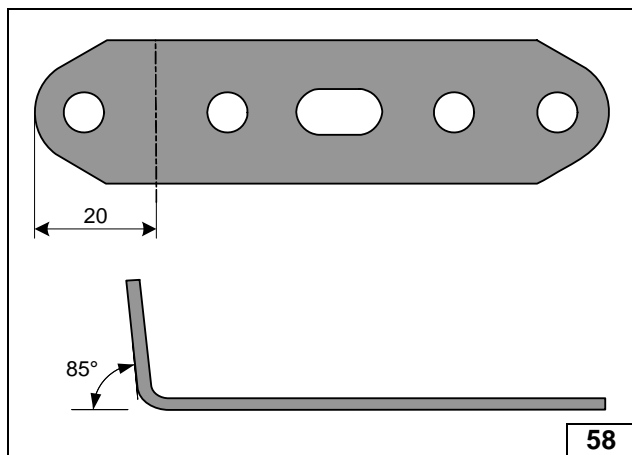

58

Preparing perforated bracket of expansion tank

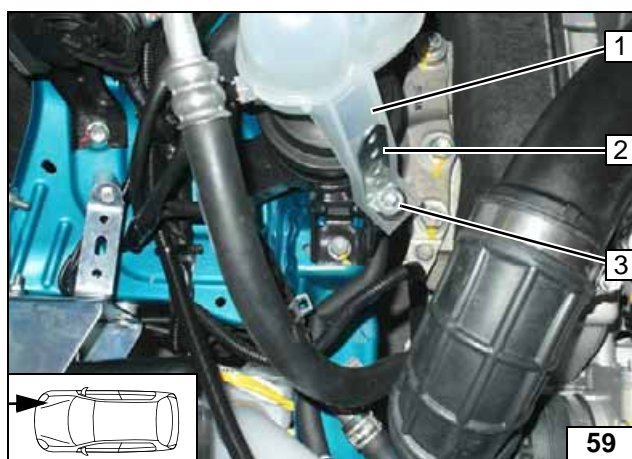

59

- 1 Expansion tank
- 2 Perforated bracket
- 3 Original vehicle bolt, original vehicle thread

Installing perforated bracket of expansion tank

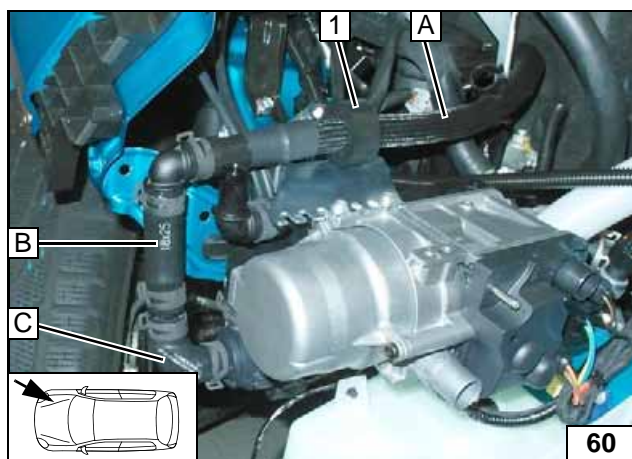

60

- 1 Black (sw) rubber isolator

Connecting circulating pump

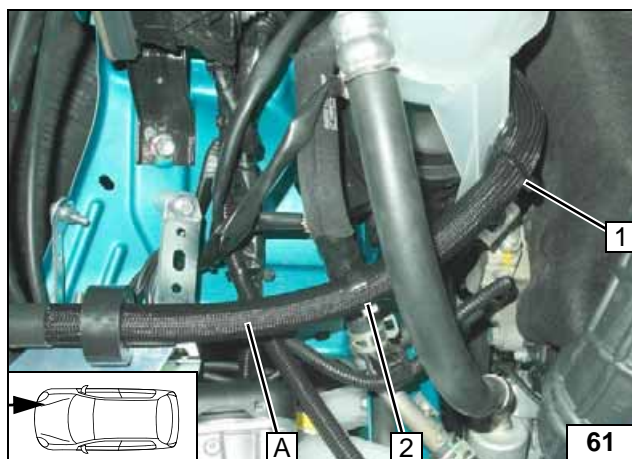

61

- 1 Fit cable tie through perforated bracket of expansion tank loosely
- 2 Hose bracket between hose section A and original vehicle hose

Routing in engine compartment

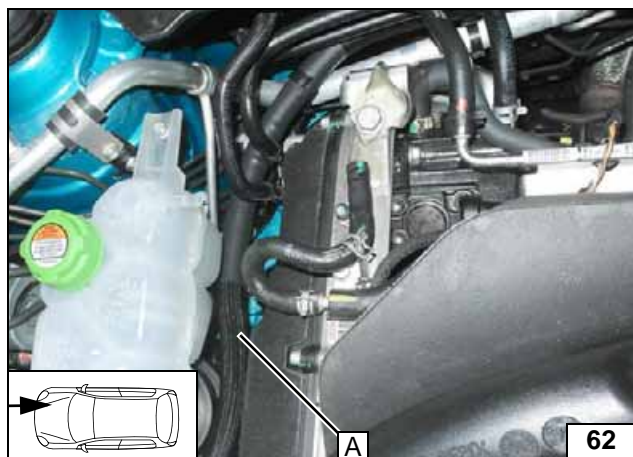

Routing in engine compartment

- 1 Hose bracket between hose section A and original vehicle line [2x]

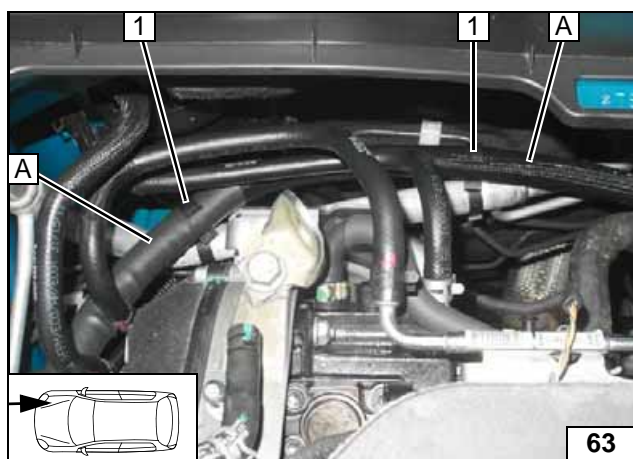

Routing in engine compartment

- 1 Engine outlet hose section

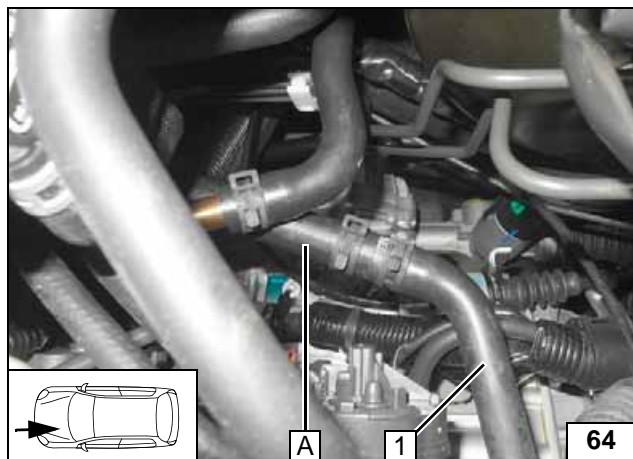

Connecting engine outlet

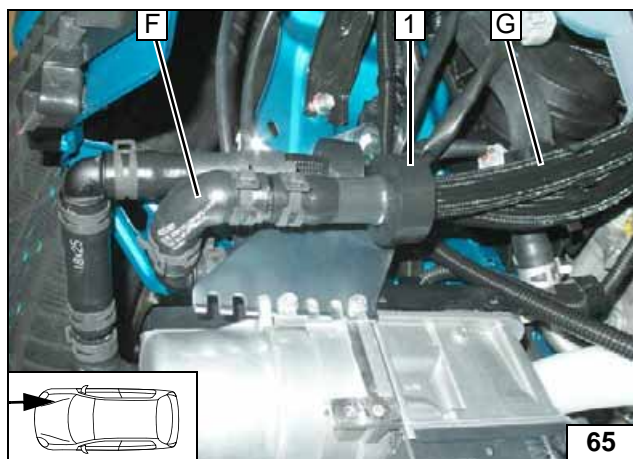

Align hoses. Ensure sufficient distance from neighbouring components, correct if necessary.



- 1 Black (sw) rubber isolator

Connecting heater outlet

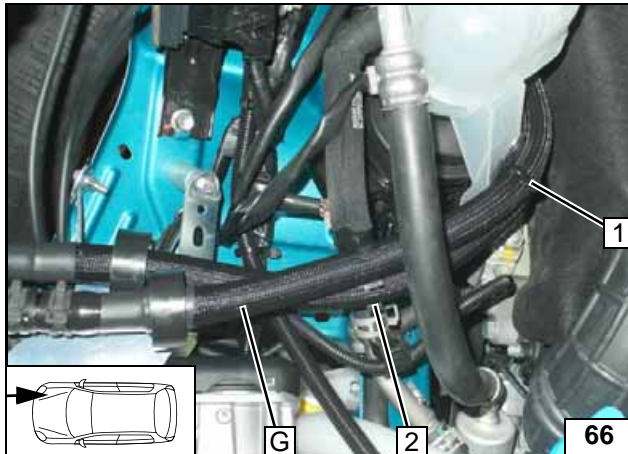
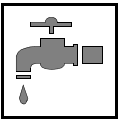

- 1 Tighten cable tie through perforated bracket of expansion tank loosely
- 2 Hose bracket between hose section **G** and original vehicle hose

Routing in engine compartment

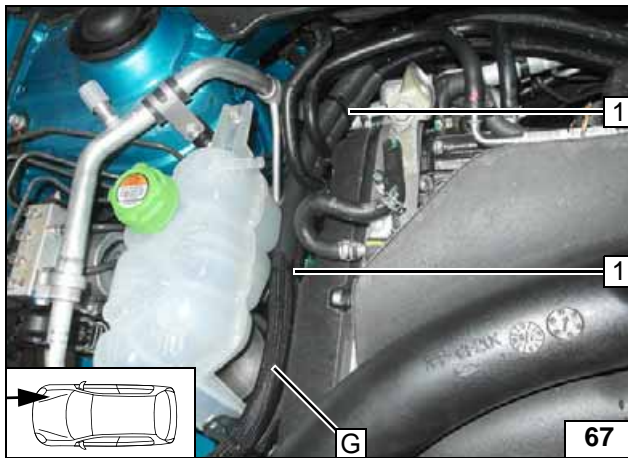

Ensure sufficient distance between hose section **A** as well as hose section **G** and engine, correct if necessary.



- 1 Cable tie [2x]

Routing in engine compartment

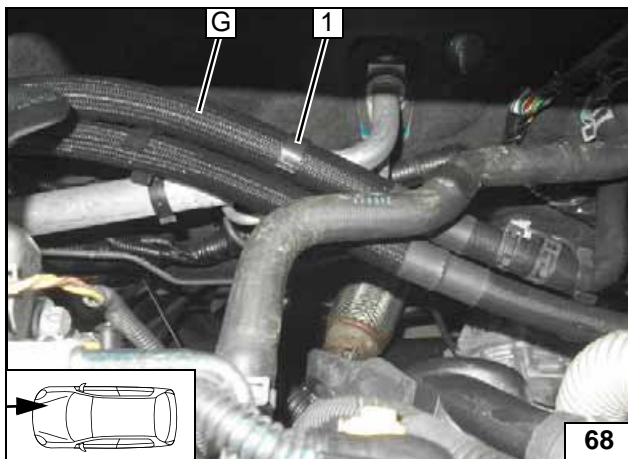

- 1 Hose bracket between hose section **G** and original line

Routing in engine compartment

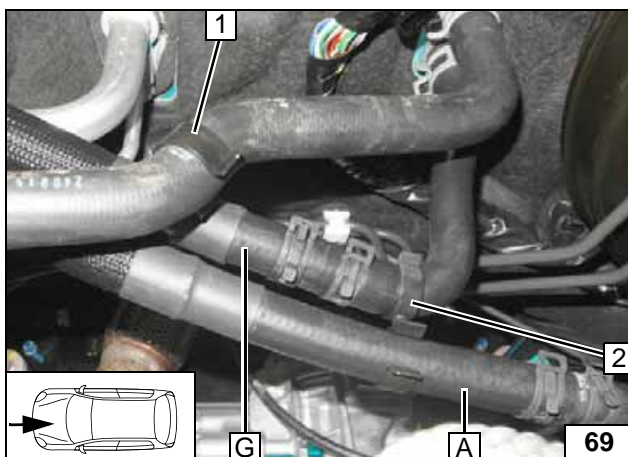

- 1 Hose bracket between hose of engine inlet / heat exchanger outlet and hose section **G**
- 2 Hose bracket between hose section of heat exchanger inlet and hose section **A**

Connecting heat exchanger inlet

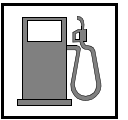

Fuel



Open the vehicle's fuel tank cap, ventilate the tank and then re-close the tank lock.

Catch any fuel running off in an appropriate container.



Route fuel line and metering pump wiring harness so that they are protected against stone impact. Unless specified otherwise, always fasten using cable ties.

Provide rub protection for fuel line and wiring harness in areas where there are sharp edges.

The fuel line and wiring harness are routed to the metering pump as shown in the wiring harness routing diagram.

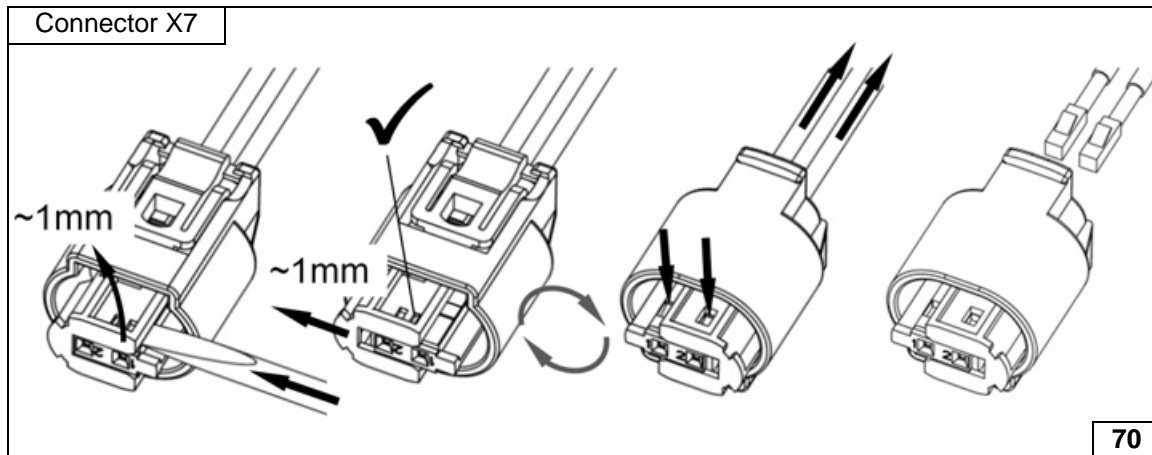

Dismantling metering pump connector

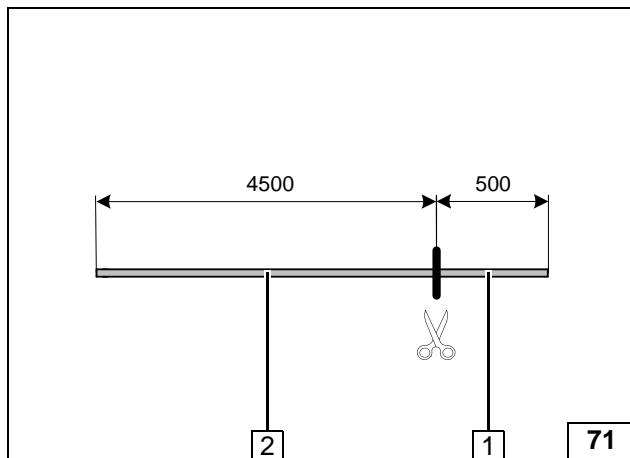

- 1 Fuel line of FuelFix
- 2 Fuel line of heater

Cutting to length / assigning fuel line

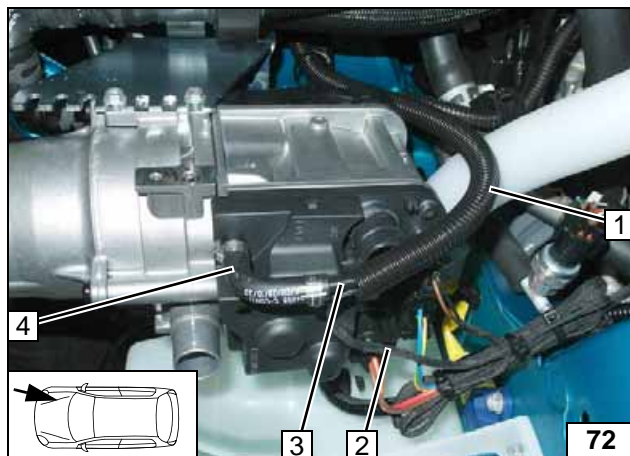

Route heater fuel line **3** and metering pump wiring harness **2** in 10 mm dia. corrugated tube **1** upwards in the engine compartment.

- 4 90° moulded hose, 10 mm dia. clamp [2x]

Routing lines

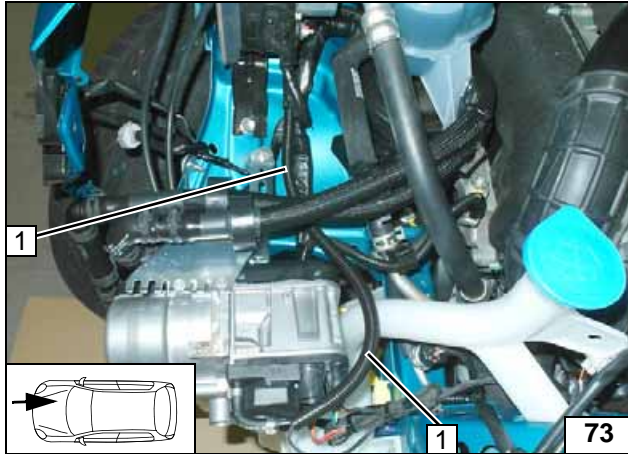

Route heater fuel line and wiring harness of metering pump in 10mm dia. corrugated tube **1** towards the firewall and further along the original vehicle lines to the underbody.



Routing lines

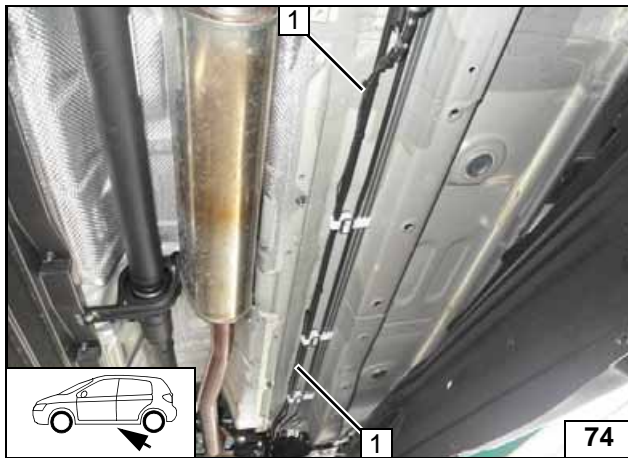

Route heater fuel line and metering pump wiring harness in 10 mm dia. corrugated tube **1** along original vehicle lines to the installation location of the metering pump.



Routing lines

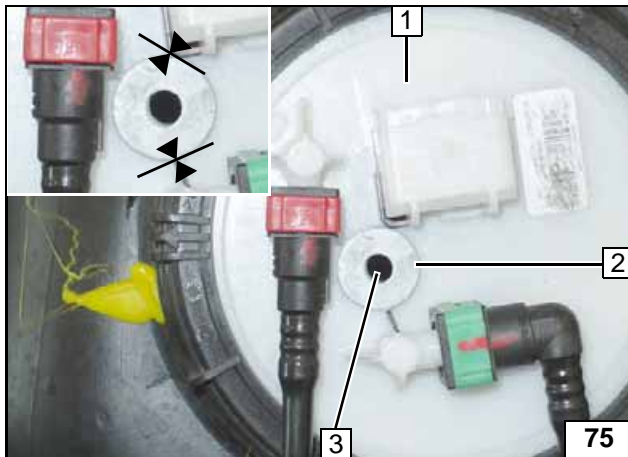

Installing FuelFix

Remove fuel tank in accordance with manufacturer's instructions.

Work steps F1 and F2.

- 1 Fuel tank sending unit
- 2 Position washer with outer dia. $d_a = 21.6\text{mm}$ as template against the raised parts.
- 3 Hole pattern



Copying hole pattern

Work step F3.

- 1 Hole made with provided drill

Hole for FuelFix

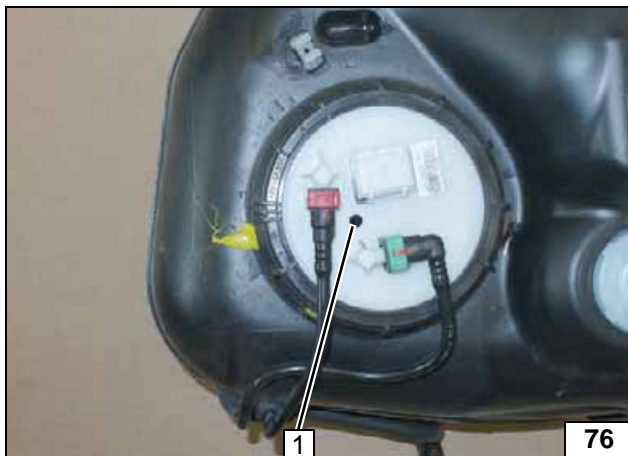

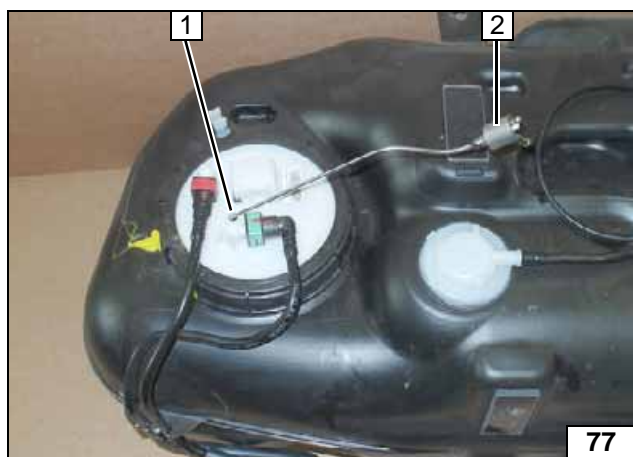

Work steps F4 and F5.

Bend FuelFix 2 according to template and cut to length. Insert into hole 1.



Inserting FuelFix



Inserting FuelFix



Inserting FuelFix



Inserting FuelFix



Work steps F5.3 and F5.4.

Align FuelFix 1 as shown.



Aligning FuelFix

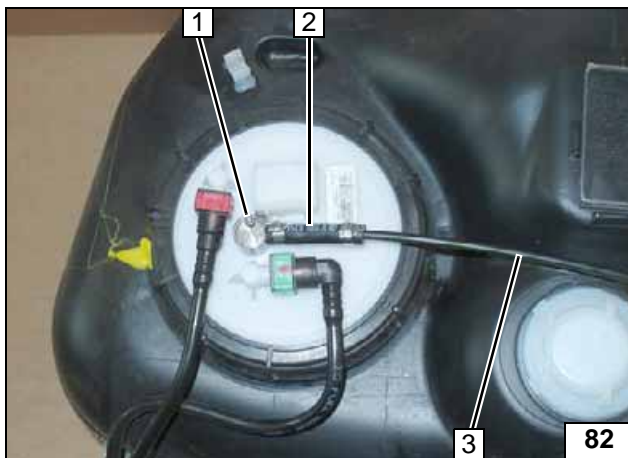

Work step F6.

- 1 FuelFix
- 2 Hose section, 10mm dia. clamp [2x]
- 3 Fuel line of FuelFix

Connect-ing fuel line

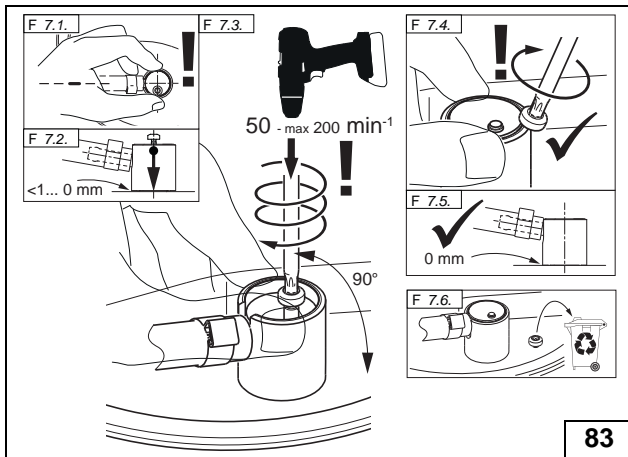

Work step F7.



Installing FuelFix



Work step F8.

Checking firm seating of FuelFix

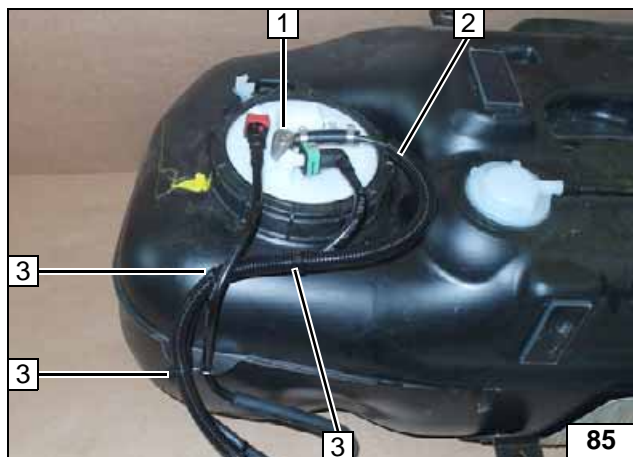

Work step F8.

- 1 FuelFix installed
- 2 Fuel line of FuelFix in corrugated tube
- 3 Cable tie as tension relief [3x]



Securing fuel line



Install fuel tank in accordance with manufacturer's instructions.

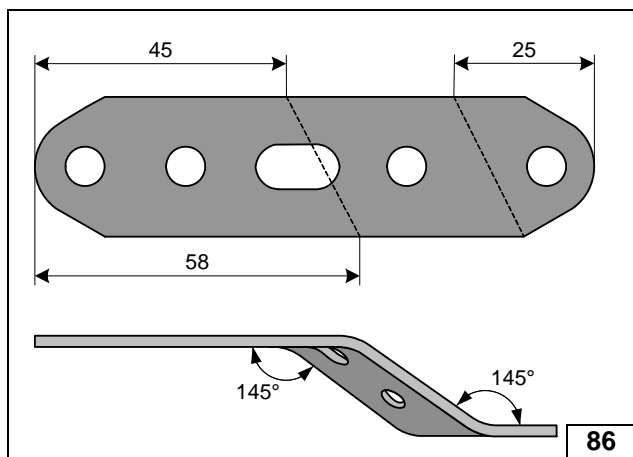

Preparing perforated bracket

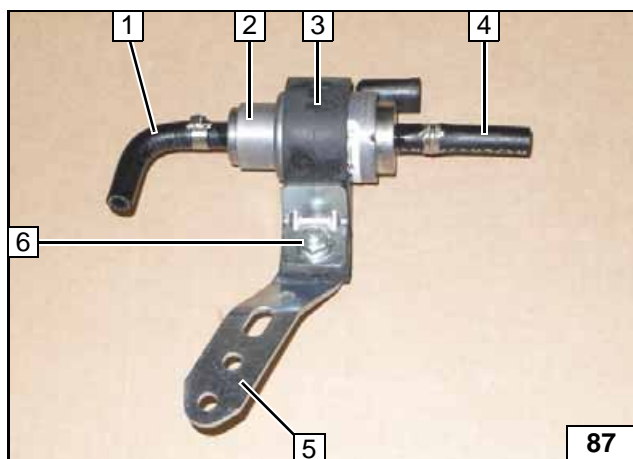

- 1 90° moulded hose, 10mm dia. clamp
- 2 Metering pump
- 3 Metering pump mount
- 4 Hose section, 10 mm dia. clamp
- 5 Perforated bracket
- 6 M6x25 bolt, support angle bracket, flanged nut

Premounting metering pump

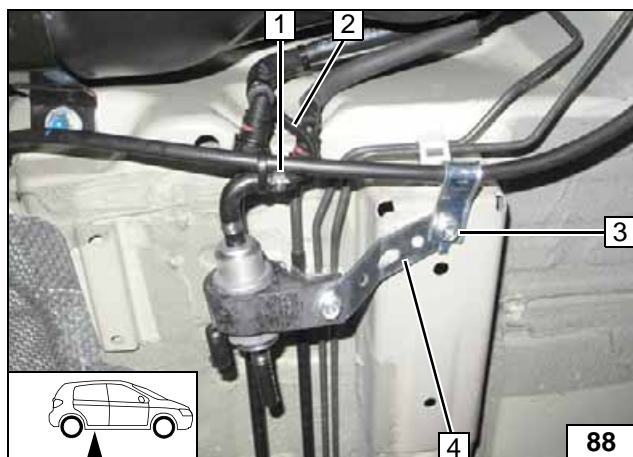

- 1 10 mm dia. clamp
- 2 Fuel line of FuelFix
- 3 Original vehicle bolt
- 4 Perforated bracket



Installing metering pump

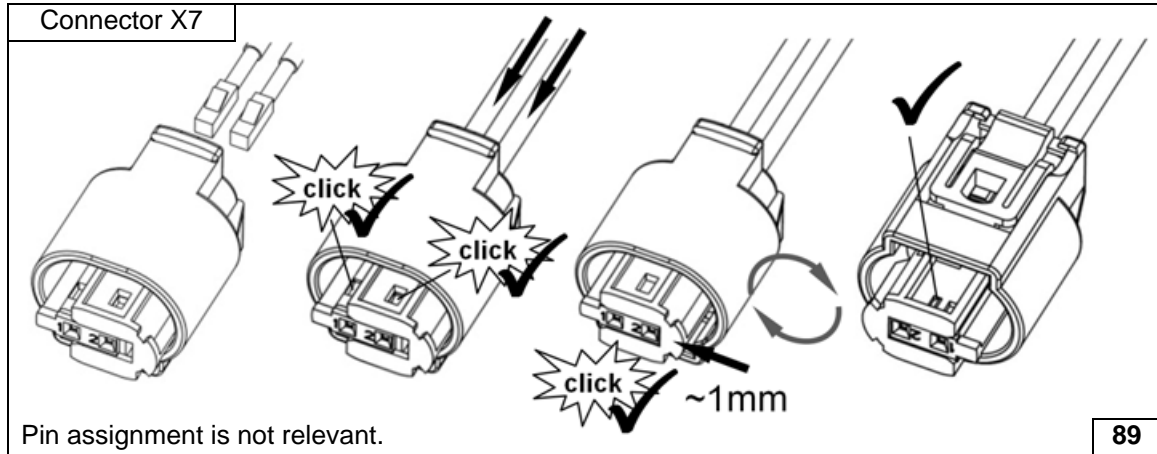

Completing metering pump connector

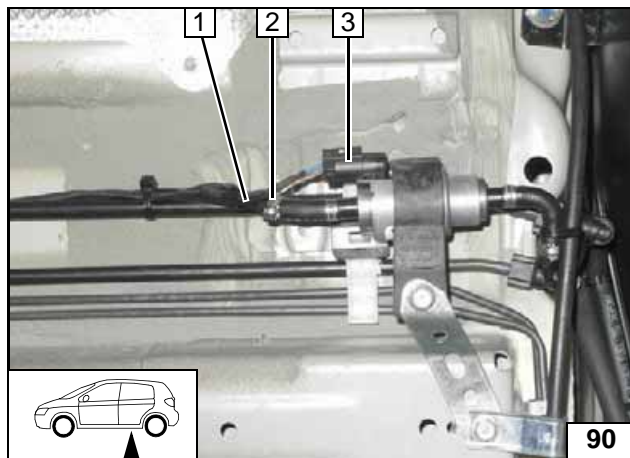

Check the position of the components; correct if necessary. Check that they have freedom of movement.

- 1 Fuel line of heater
- 2 10 mm dia. clamp
- 3 Metering pump wiring harness, connector X7 installed



Connecting metering pump

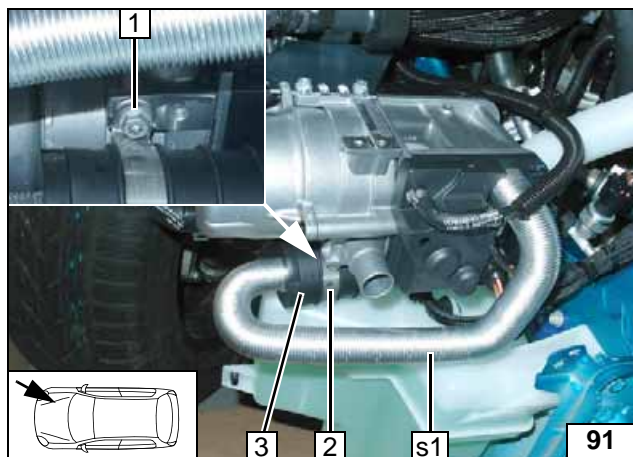
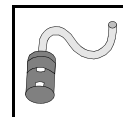

Combustion Air

- 1 M5x13 self-tapping bolt, existing hole in heater
- 2 51 mm dia. clamp
- 3 Silencer



Installing combustion air pipe s1 and silencer

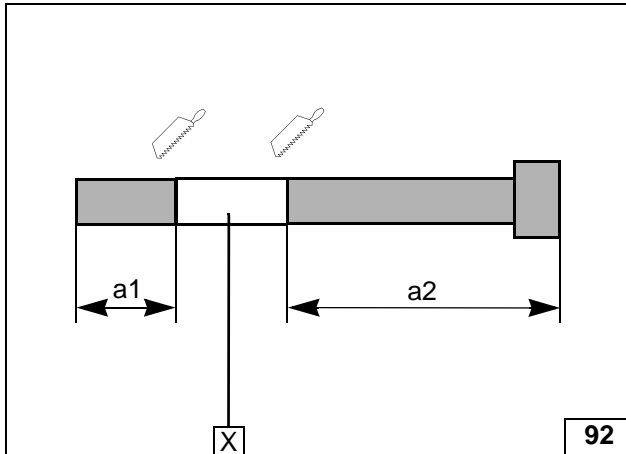
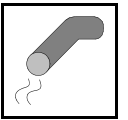

Exhaust Gas

a1 = 150
a2 = 480

X =

Preparing exhaust pipe

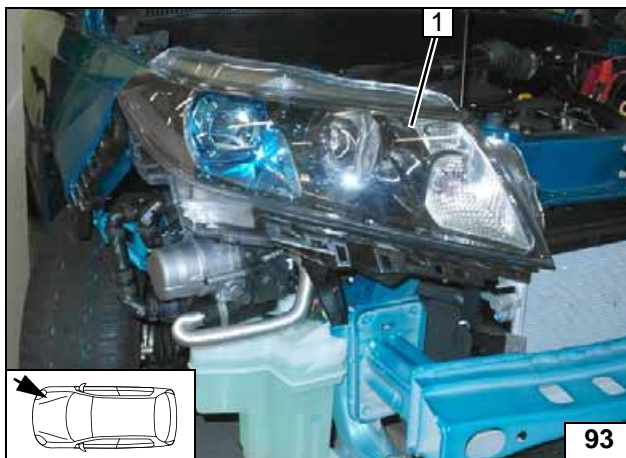

1 Headlight

Installing headlight

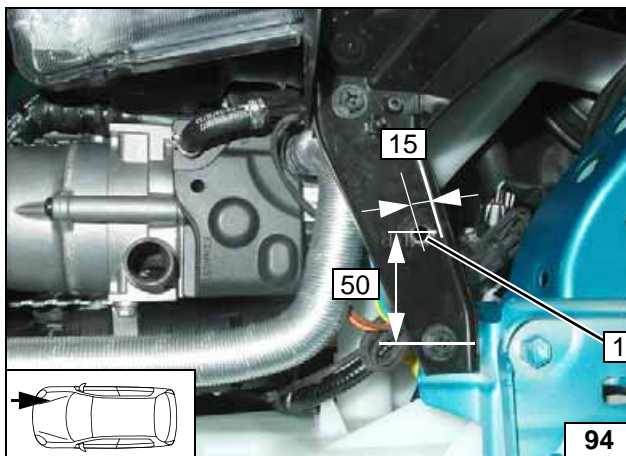

1 7mm dia. hole in original vehicle bracket

Copying hole pattern

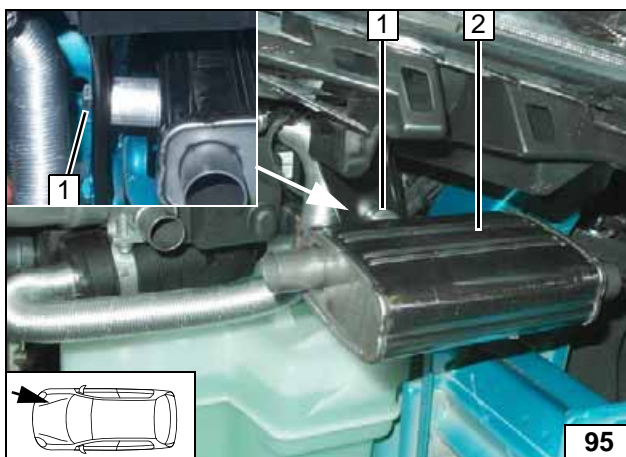

1 M6x35 bolt, spring lockwasher, 5 mm shim, 20mm shim
2 Silencer

Mounting silencer

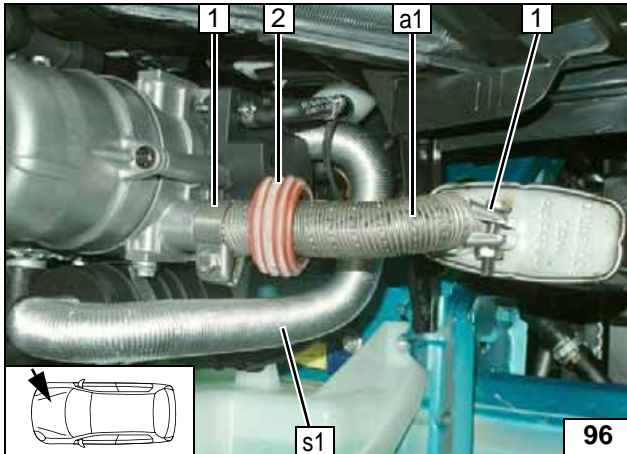
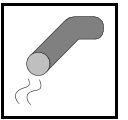

Ensure sufficient distance between exhaust pipe **a1** and combustion air pipe **s1**, correct if necessary.

- 1 Hose clamp [2x]
- 2 Spacer bracket



Installing exhaust pipe a1

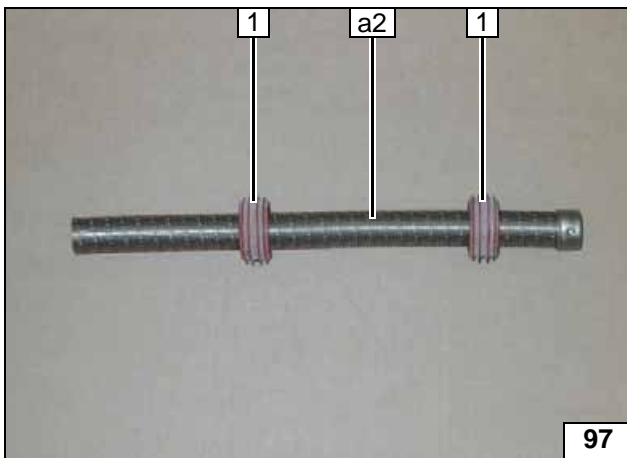

- 1 Spacer bracket [2x]

Premounting exhaust pipe a2

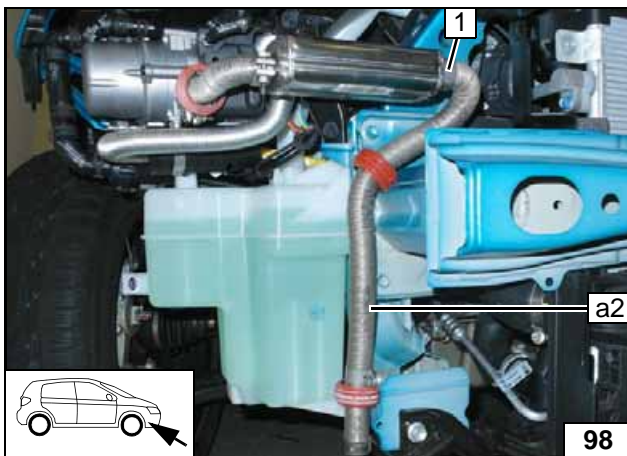

- 1 Hose clamp

Installing exhaust pipe a2

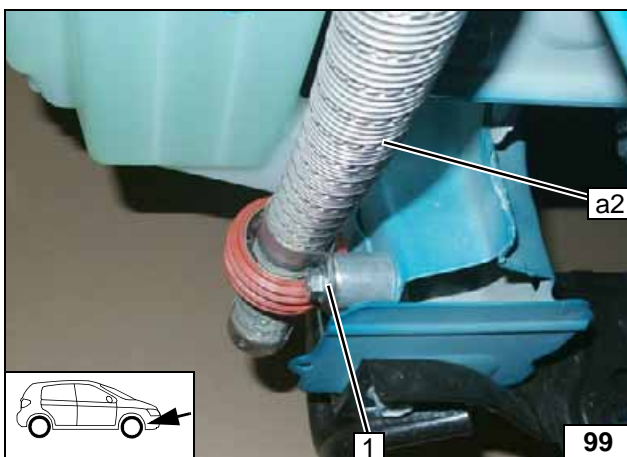

- 1 M6x35 bolt, 20mm shim, p-clamp, M6 flanged nut, existing hole

Installing exhaust pipe a2

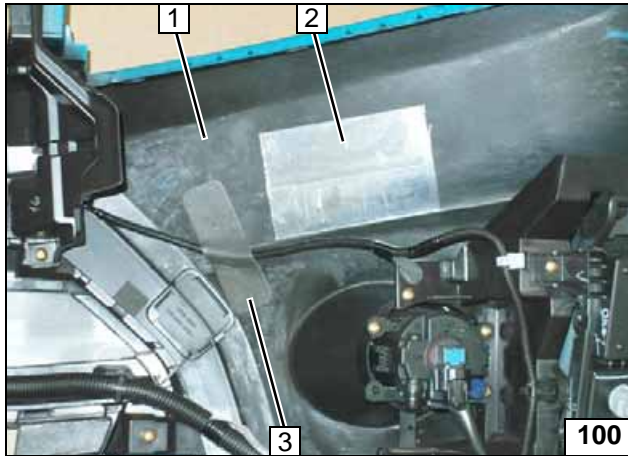

Cut aluminium foil tape **2** in half and stick on as shown.
Attach original vehicle wiring harness of distance warning system as shown using self-adhesive foam **3**.



Sticking on aluminium foil tape

1 Bumper

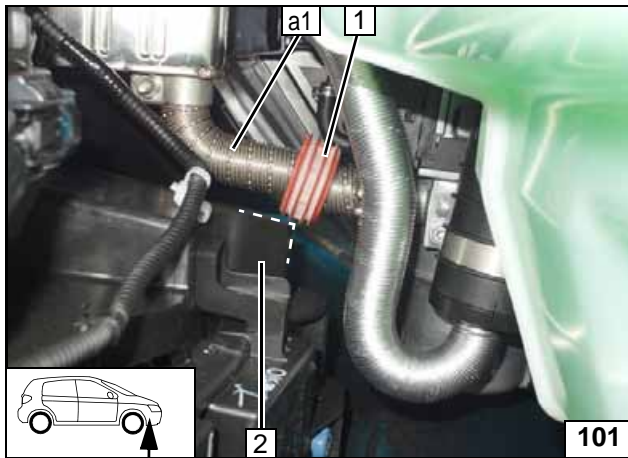

Install bumper.
Align spacer bracket **1** with front fog light bracket **2**.



Aligning exhaust pipe a1



Ensure sufficient distance from neighbouring components (at least 20mm), correct if necessary.



Aligning exhaust pipe

1 Bumper

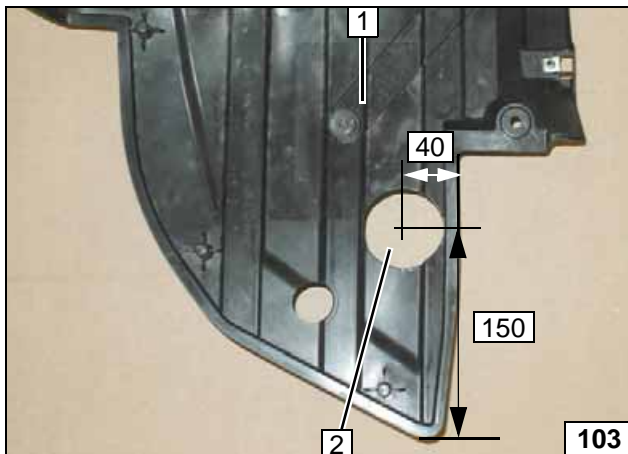

1 Wheel well trim
2 60 mm dia. hole

Hole in wheel well trim

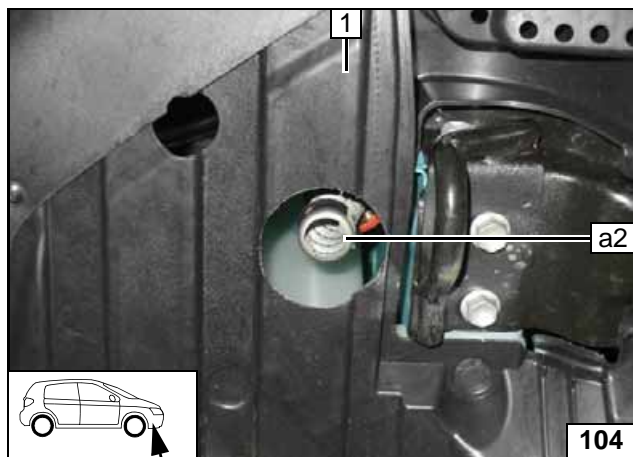
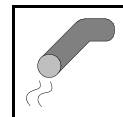

Align exhaust pipe **a2** in the centre. Ensure sufficient distance from neighbouring components, correct if necessary.



- 1 Wheel well trim

Installing wheel well trim

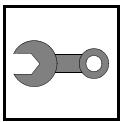

Final Work



Reassemble the components in reverse order. Check all hoses, clamps and all electrical connections for firm seating. Insulate loose wire ends and tie back.
Only use manufacturer-approved coolant. Spray the heater components with anti-corrosion wax (Tectyl 100K).

- Connect the battery.
- Fill and bleed the coolant circuit according to the vehicle manufacturer's specifications.
- Program MultiControl CAR, teach Telearstart transmitter.
- Make settings on the A/C control panel according to the 'operating instructions'.
- Place the 'Switch off parking heater before refuelling' caution label near the filler neck.
- For initial startup and function check, please see installation instructions.

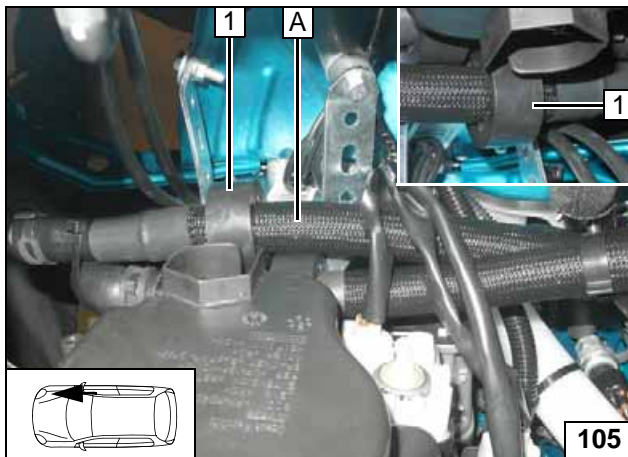

1 Black (sw) rubber isolator

Aligning rubber isolator

Webasto Thermo & Comfort SE
Postfach 1410
82199 Gilching
Germany
Internet: www.webasto.com
Technical Extranet:
<http://dealers.webasto.com>



Template for FuelFix

Top view

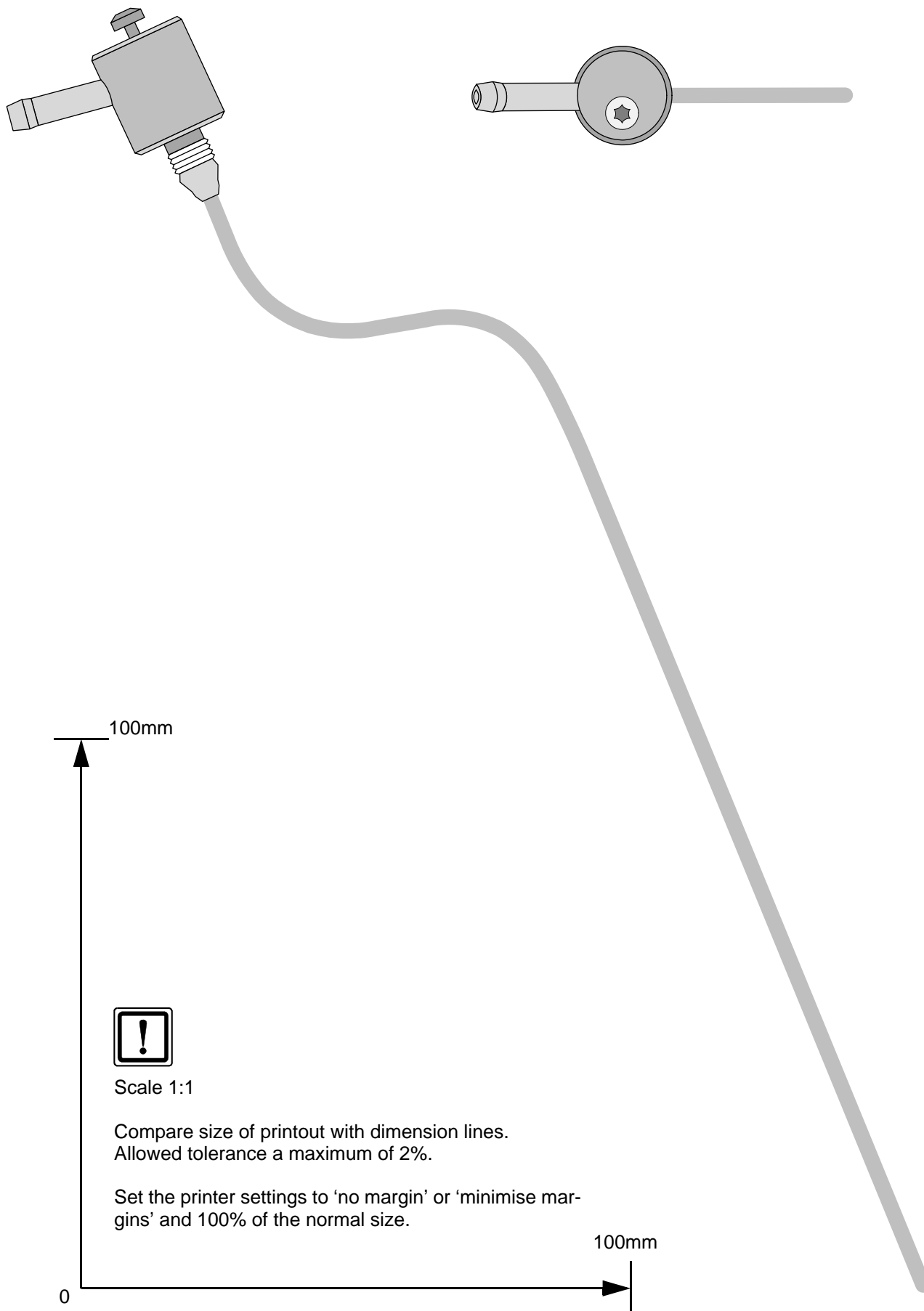

Scale 1:1

Compare size of printout with dimension lines.
Allowed tolerance a maximum of 2%.

Set the printer settings to 'no margin' or 'minimise margins' and 100% of the normal size.

Operating Instructions for Manual Air-Conditioning

Please remove page and add to the vehicle operating instructions.

Note:

We recommend matching the heating time to the driving time.

Heating time = driving time

Example:

For a driving time of approx. 20 min. (in one direction), we recommend not exceeding a switch-on time of 20 min.

Passenger compartment monitoring, if installed, must be deactivated in addition to the vehicle settings for the heating operation.

For instructions on deactivation, please refer to the operating instructions of the vehicle.

Before parking the vehicle, make the following settings:

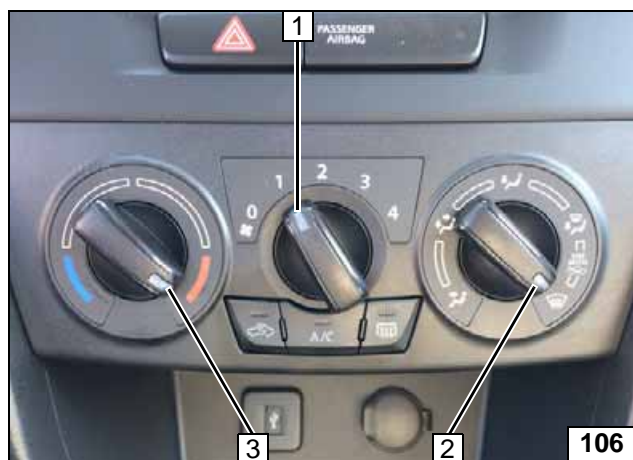

- 1 Set fan to level '1' or max. '2'
- 2 Air outlet to windscreen
- 3 Set temperature to 'max.'

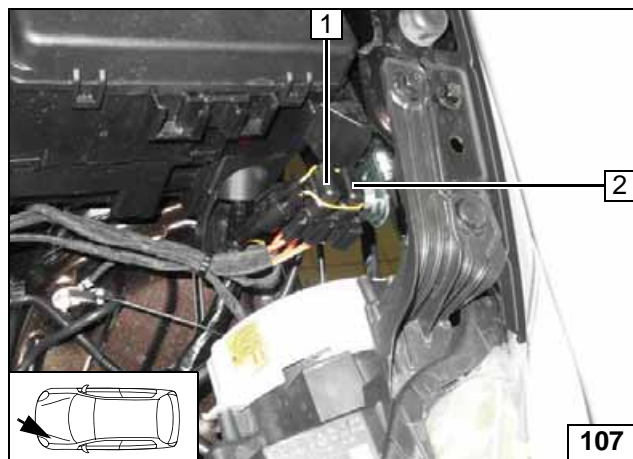

- 1 20A heater fuse F1
- 2 30A passenger compartment main fuse F2

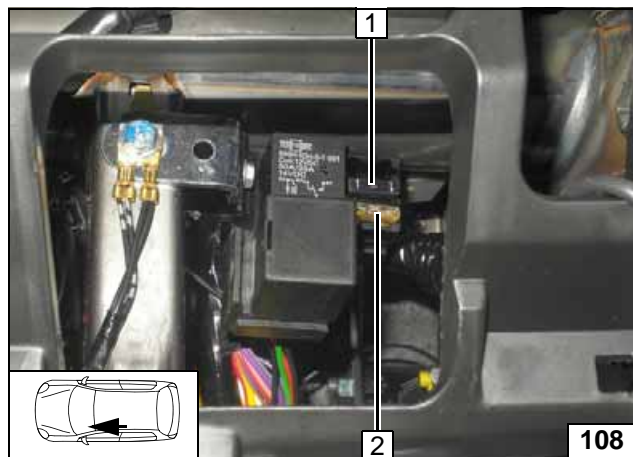

- 1 1A heater control fuse F3
- 2 25A fan fuse F4



A/C control panel

Engine compartment fuses

Passenger compartment fuses

Operating Instructions for Automatic Air-Conditioning

Please remove page and add to the vehicle operating instructions.

Note:

We recommend matching the heating time to the driving time.
 Heating time = driving time

Example:

For a driving time of approx. 20 min. (in one direction), we recommend not exceeding a switch-on time of 20 min.

Passenger compartment monitoring, if installed, must be deactivated in addition to the vehicle settings for the heating operation.

For instructions on deactivation, please refer to the operating instructions of the vehicle.

Before parking the vehicle, make the following settings:



- 1 Set temperature to 'HI'
- 2 Air outlet to windscreen



A/C control panel

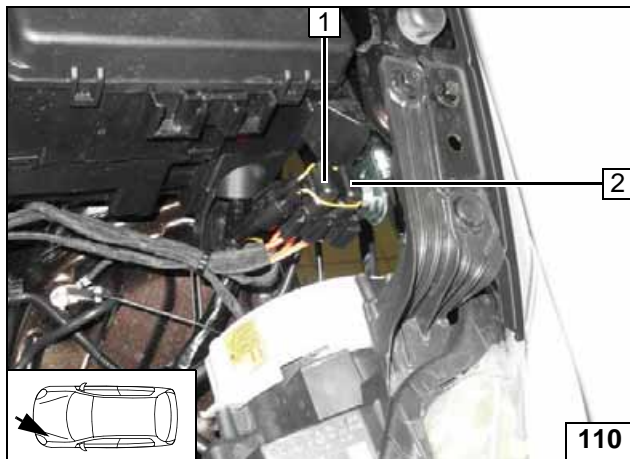

- 1 20A heater fuse F1
- 2 30A passenger compartment main fuse F2

Engine compartment fuses

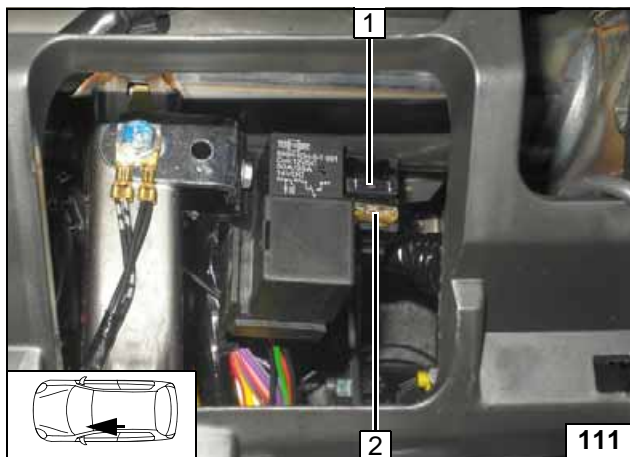

- 1 1A heater control fuse F3
- 2 25A fan fuse F4

Passenger compartment fuses

