



# Water Heater

## Thermo Top Evo Parking Heater



With FuelFix

# Installation Documentation Mercedes GLC BR253

### Validity

Manufacturer	Model	Type	EG BE No. / ABE
Mercedes	GLC	253	e1 * 2001 / 116 * 0481 * ...

Motorisation	Fuel	Transmission type	Output in kW	Displacement in cm <sup>3</sup>	Engine code
GLC 220 d	Diesel	AG	125	2143	OM651
GLC 250 d	Diesel	AG	150	2143	OM651

AG = automatic transmission

**From model year 2016**  
**Left-hand drive vehicle**

**Verified equipment variants:** 2-zone THERMATIC  
Passenger compartment monitoring  
Headlight washer system  
LED headlight  
Start / Stop  
Euro 6  
4Matic

**Not verified:** 3-zone THERMOTRONIC

**Total installation time:** approx. 7.0 hours

# Mercedes GLC BR253

## Table of Contents

Validity	1	Preparing Installation Location	10
Necessary Components	2	Preparing Heater	14
Installation Overview	2	Installing Heater	15
Information on Total Installation Time	2	Exhaust Gas	17
Information on Operating and Installation Instructions	3	Coolant Circuit	19
Information on Validity	4	Fuel	24
Technical Information	4	Installing FuelFix	26
Explanatory Notes on Document	4	Combustion Air	30
Preliminary Work	5	Final Work	31
Heater Installation Location	5	FuelFix Template	33
Electrical System	6		
Air-Conditioning Control	8		
Remote Option (Telestart)	8		
ThermoCall Option	9		

## Necessary Components

- Basic delivery scope of Thermo Top Evo according to price list
- Installation kit with FuelFix for Mercedes GLC BR253 2016 Diesel: **1324966B**
- Additional kit 'Webasto Comfort' A/C control for Mercedes C-Class / GLC: **1324395\_**
- Heater control in accordance with price list and upon consultation with end customer
- The installation location should be confirmed with the end customer in case of MultiControl.
- In case of Telestart, indicator lamp in accordance with price list and in consultation with end customer

## Installation instructions:

- Arrange for the vehicle to be delivered with the tank only about  $\frac{1}{4}$  full.
- The installation location of the push button in case of Telestart or ThermoCall should be confirmed with the end customer.
- Depending on the space required and the vehicle manufacturer's instructions, we recommend the use of a vehicle battery with a higher electrical capacity.

## Installation Overview

### Legend:

1. Heater
2. Engine compartment fuse holder
3. Circulating pump
4. Telestart Option Receiver
5. Metering pump
6. FuelFix

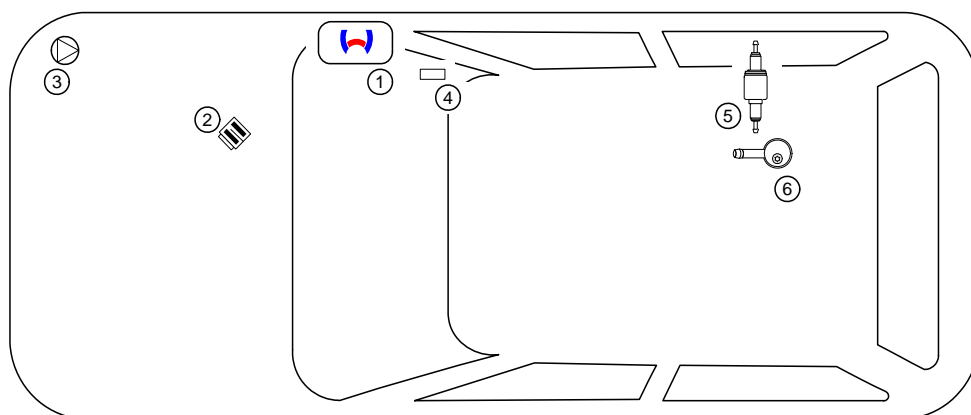

## Information on Total Installation Time

The total installation time includes the time needed for mounting and demounting the vehicle-specific components, the heater specific installation time and all other times required for the system integration and initial start-up of the heater. The total installation time may vary for vehicle equipment other than provided.

## Information on Operating and Installation Instructions

### 1 Important information (not complete)

#### 1.1 Installation and repair



The improper installation or repair of Webasto heating and cooling systems can cause fire or the leakage of deadly carbon monoxide, leading to serious injury or death.



To install and repair Webasto heating and cooling systems you need to have completed a special company training course and have the appropriate technical documentation, special tools and special equipment.



Installation and repair may **ONLY** be carried out by persons trained and certified in a Webasto training course. **NEVER** try to install or repair Webasto heating or cooling systems if you have not completed a Webasto training course, you do not have the necessary technical skills and you do not have the technical documentation, tools and equipment available to ensure that you can complete the installation and repair work properly.

Only use genuine Webasto parts. See the Webasto air and water heaters accessories catalogue for this purpose.

#### 1.2 Operation

To ensure safe operation, we recommend having the heater checked every two years by an authorised Webasto dealer, especially when used over a long period and/or under extreme environmental conditions.

Do not operate the heater in closed rooms due to the danger of poisoning and suffocation.

Always switch off the heater before refuelling.

The heater may only be used with the prescribed fuel diesel (DIN EN 590) or petrol (DIN EN 228).

The heater may not be cleaned with a high-pressure cleaner.

#### 1.3 Please note

ALWAYS follow all Webasto installation and operating instructions and observe all warnings.

To become familiar with and understand all functions and properties of the heater, the operating instructions must be read carefully and observed at all times.

For proper, safe installation and repair work, the installation instructions with all warnings and safety information must be carefully read and observed at all times. Please always contact a workshop authorised by Webasto for all installation and repair work.

#### Important

**Webasto shall assume no liability for defects, damage and injuries resulting from a failure to observe the installation, repair and operating instructions of the information contained in them.**

**This liability exclusion particularly applies to improper installations and repairs, installations and repairs by untrained persons or in the case of a failure to use genuine spare parts.**

**The liability due to culpable disregard to life, limb or health and due to damage or injuries caused by a wilful or reckless breach of duty remain unaffected, as does the obligatory product liability.**

Installation should be carried out according to the general, standard rules of technology. Unless specified otherwise, fasten hoses, lines and wiring harnesses to original vehicle lines and wiring harnesses using cable ties. Insulate loose wire ends and tie back. Connectors on electronic components must audibly snap into place during assembly.

Sharp edges should be fitted with rub protection. Spray unfinished body areas, e.g. drilled holes, with anti-corrosion wax (Tectyl 100K).

Observe the instructions and guidelines of the respective vehicle manufacturer for demounting and mounting vehicle specific components!

The initial startup is to be executed with the Webasto Thermo Test Diagnosis.

When installing a programmable control module (e.g. a PWM Gateway), the corresponding settings must be checked or adjusted.

### 2 Statutory regulations governing installation

Guidelines	Thermo Top Evo
Heating Directive ECE R122	E1 00 0258
EMC Directive ECE R10	E1 04 5627

#### Note

The regulations of these guidelines are binding in the scope of the Directive 70/156/EEC and/or 2007/46/EC (for new vehicle models from 29/04/2009) and should also be observed in countries in which there are no special regulations.

#### Important

Failure to follow the installation instructions will result in the invalidation of the type approval for the heater and therefore invalidation of the general **homologation of the vehicle**.

#### Note

The heater is licensed in accordance with paragraph 19, section 3, No. 2b of the StVZO (German Road Traffic Licensing Authority).

### 2.1 Excerpt from ECE regulation 122 (heating system) paragraph 5 for the installation of the heater

Beginning of excerpt.

#### ANNEX VII

#### REQUIREMENTS FOR COMBUSTION HEATERS AND THEIR INSTALLATION

##### 1. GENERAL REQUIREMENTS

1.7.1. A clearly visible tell-tale in the operator's field of view shall inform when the combustion heater is switched on or off.

##### 2. VEHICLE INSTALLATION REQUIREMENTS

###### 2.1. Scope

2.1.1. Subject to paragraph 2.1.2, combustion heaters shall be installed according to the requirements of this Annex.

2.1.2. Vehicles of category O having liquid fuel heaters are deemed to comply with the requirements of this Annex.

###### 2.2. Positioning of heater

2.2.1. Body sections and any other components in the vicinity of the heater must be protected from excessive heat and the possibility of fuel or oil contamination.

2.2.2. The combustion heater shall not constitute a risk of fire, even in the case of overheating. This requirement shall be deemed to be fulfilled if the installation ensures an adequate distance to all parts and suitable ventilation, by the use of fire resistant materials or by the use of heat shields.

2.2.3. In the case of M2 and M3 vehicles, the heater must not be positioned in the passenger compartment. However, an installation in an effectively sealed envelope which also complies with the conditions in paragraph 2.2.2 may be used.

2.2.4. The label referred to in paragraph 1.4 or a duplicate, must be positioned so that it can be easily read when the heater is installed in the vehicle.

2.2.5. Every reasonable precaution should be taken in positioning the heater to minimise the risk of injury and damage to personal property.

###### 2.3. Fuel supply

2.3.1. The fuel filler must not be situated in the passenger compartment and must be provided with an effective cap to prevent fuel spillage.

2.3.2. In the case of liquid fuel heaters, where a supply separate to that of the vehicle is provided, the type of fuel and its filler point must be clearly labelled.

2.3.3. A notice, indicating that the heater must be shut down before refuelling, must be affixed to the fuelling point. In addition a suitable instruction must be included in the manufacturer's operating manual.

###### 2.4. Exhaust system

2.4.1. The exhaust outlet must be located so as to prevent emissions from entering the vehicle through ventilators, heated air inlets or opening windows.

###### 2.5. Combustion air inlet

2.5.1. The air for the combustion chamber of the heater must not be drawn from the passenger compartment of the vehicle.

2.5.2. The air inlet must be so positioned or guarded that blocking by rubbish or luggage is unlikely.

###### 2.6. Heating air inlet

2.6.1. The heating air supply may be fresh or recirculated air and must be drawn from a clean area not likely to be contaminated by exhaust fumes emitted either by the propulsion engine, the combustion heater or any other vehicle source.

2.6.2. The inlet duct must be protected by mesh or other suitable means.

###### 2.7. Heating air outlet

2.7.1. Any ducting used to route the hot air through the vehicle must be so positioned or protected that no injury or damage could be caused if it were to be touched.

2.7.2. The air outlet must be so positioned or guarded that blocking by rubbish or luggage is unlikely.

End of excerpt.

In multilingual versions the German language is binding.

# Mercedes GLC BR253

## Information on Validity

This installation documentation applies to Mercedes GLC BR253 Diesel vehicles - for validity, see page 1 - from model year 2016 and later, assuming technical modifications to the vehicle do not affect installation, any liability claims excluded. Depending on the vehicle version and equipment, modifications may be necessary during installation with respect to this 'installation documentation'.

Vehicle and engine types, equipment variants and other specifications not listed in this installation documentation have not been tested. However, installation according to this installation documentation may be possible.

## Technical Information

### Special Tools

- Hose clamp pliers for auto-tightening hose clamps
- Hose clamp pliers for Clic hose clamps of type W
- Automatic wire stripper, 0.2 - 6mm<sup>2</sup>
- Crimping pliers for cable lug / tab connector, 0.5 - 6mm<sup>2</sup>
- Torque wrench for 2.0 - 10 Nm
- Hose clamping pliers
- Deep-hole marker
- Metric thread-setter kit
- Webasto Thermo Test Diagnosis with current software

### Dimensions

- All dimensions are in mm.

### Tightening torque values

- Tightening torque values of 5x13 heater bolts and 5x11 heater stud bolts = 8Nm.
- Tightening torque value of 5x15 water connection piece retaining plate bolt = 7Nm.
- Tighten other bolt connections in accordance with manufacturer's instructions or in accordance with state-of-the-art technology.

## Explanatory Notes on Document

You will find an identification mark on the outside top right corner of the page in question to provide you with a quick overview of the individual working steps.

Special features are highlighted using the following symbols:

**Mechanical System**



**Electrical System**



**Coolant Circuit**



**Combustion Air**



**Fuel**



**Exhaust Gas**



**Software**



**Specific risk of damage to components.**



**Specific risk due to electrical voltage.**



**Specific risk of injury or fatal accidents.**



**Specific risk of fire or explosion.**



**Reference to the manufacturer's vehicle-specific documents or to the general installation instructions of Webasto components.**



**Reference to a special technical feature.**



**The arrow in the vehicle icon indicates the position on the vehicle and the viewing angle.**



**Tightening torque according to the manufacturer's vehicle-specific documents.**



## Preliminary Work

### Vehicle



- Open the fuel tank cap.
- Ventilate the fuel tank.
- Close the fuel tank cap again.
- Depressurise the cooling system.
- Remove the right front wheel.
- Remove the wheel well trim on the right.
- Remove the lower engine cover.
- Remove the underbody trim on the right.
- Disconnect and remove the battery.
- Drain off the engine coolant and set aside.
- Remove the seat bench of the rear bench seat.
- Open the right-hand tank-fitting service lid.

### Heater

- Remove years that do not apply from the type and duplicate label.
- Attach the duplicate label (type label) visibly in the appropriate place in the engine compartment.

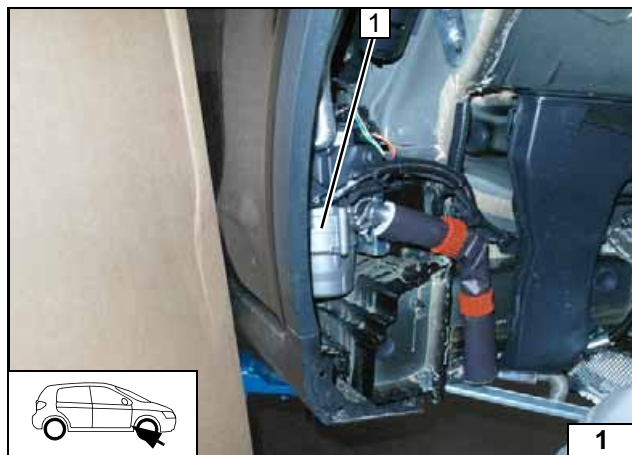

### Heater Installation Location

- 1 Heater

Installation location



**Electrical System**



**Earth wire**

- 1 8mm dia. cable lug, earth wire on original vehicle earth support point

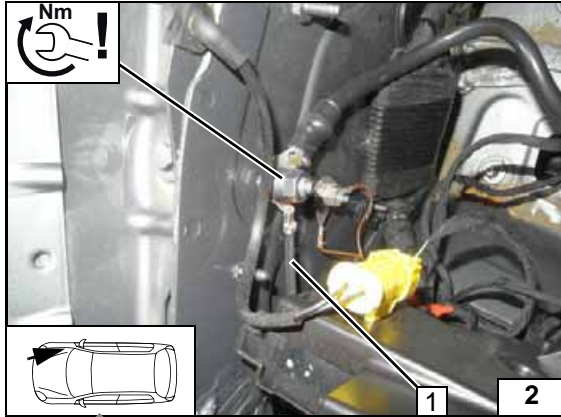

**Wiring harness pass through**

- 1 Protective rubber plug, use lower perforation
- 2 Wiring harnesses of heater, heater control
- 3 Cable tie

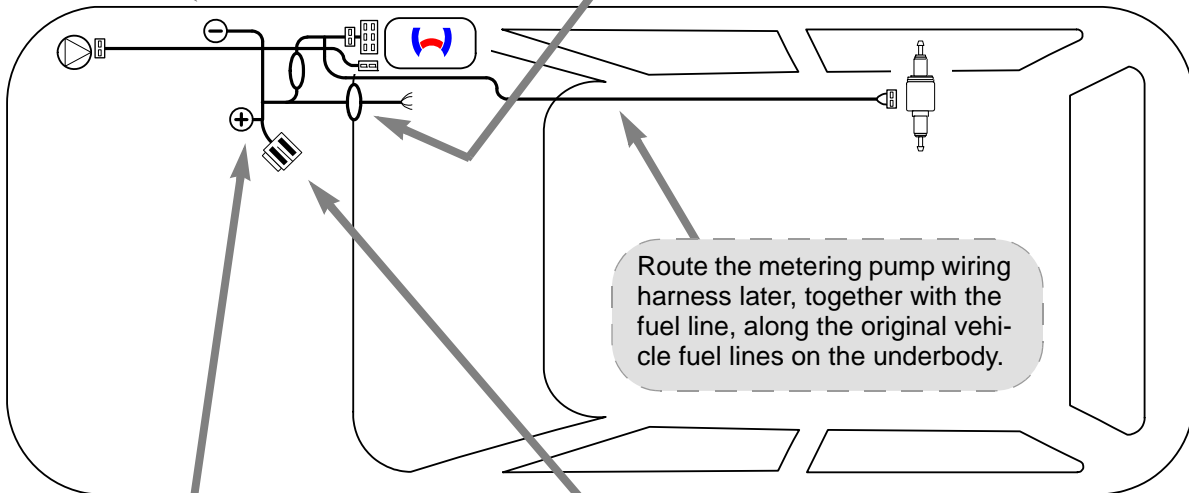
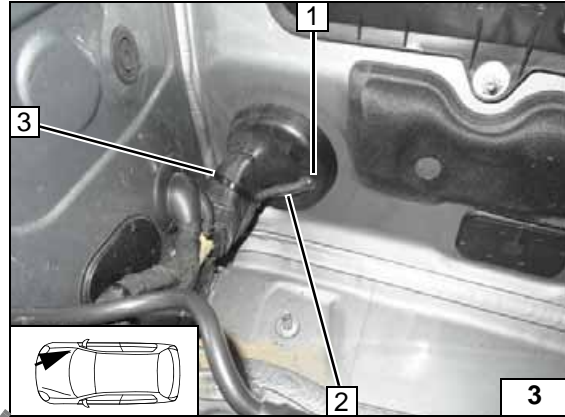

**Wiring harness routing diagram**

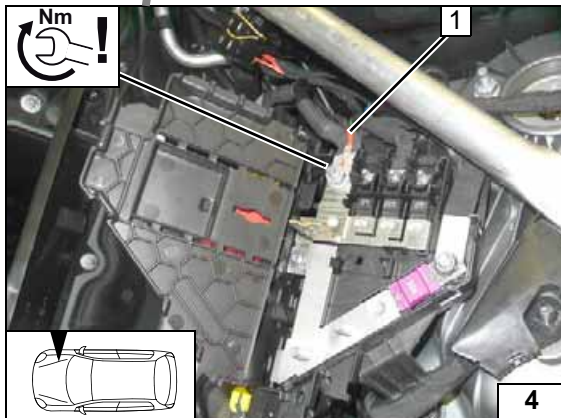

**Positive wire**

- 1 8mm dia. cable lug, positive wire on original vehicle positive support point

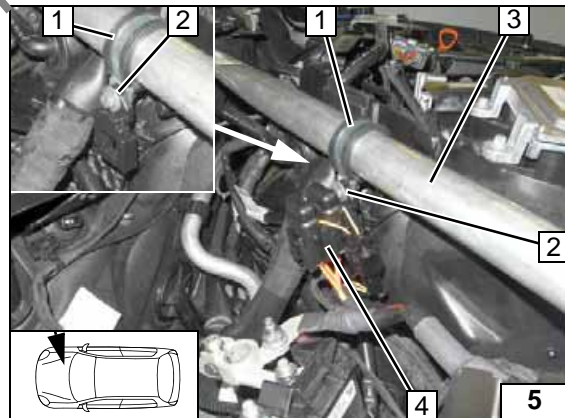

**Engine compartment fuse holder**

- 1 29 mm dia. rubber-coated p-clamp
- 2 M5x16 bolt, large diameter washer [2x], retaining plate of fuse holder, nut
- 3 Right engine compartment stiffening brace
- 4 Insert F1-2 fuses



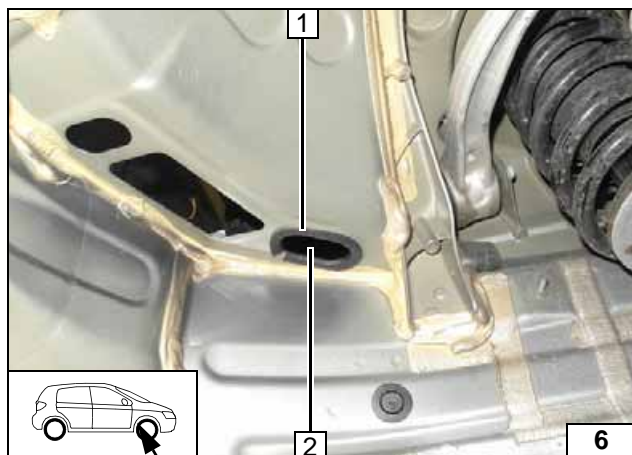

Drain pipe removed for documentary purposes.  
Remove sealing plug at position 2.



- 1 155 mm narrow edge protection

**Installing edge protection**

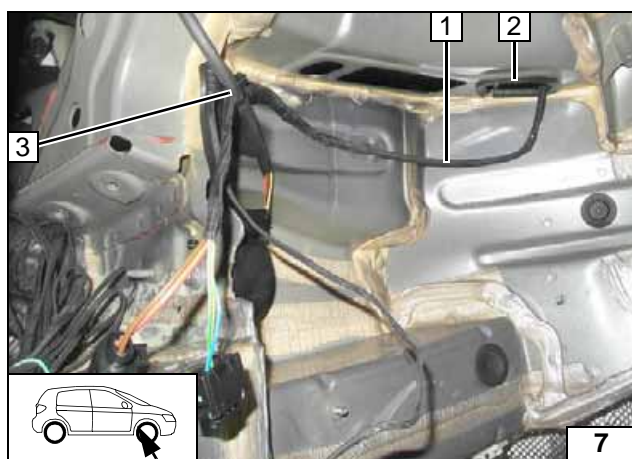

Route heater wiring harness 1 through original vehicle pass through 2 in wheel well.



- 3 Cable tie (if original vehicle wire is present)

**Routing heater wiring harness**



## Air-Conditioning Control



Connect the A/C control in accordance with the separate installation documentation:

Installation documentation '**Webasto Comfort**' A/C control for Mercedes GLC BR253

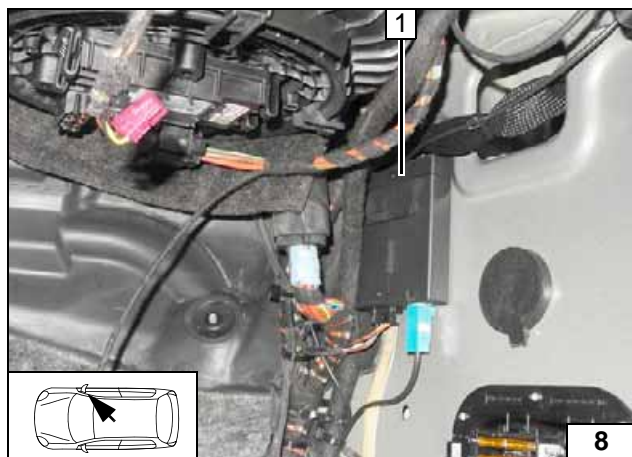

### Remote Option (Telestart)

Fasten receiver 1 with double-sided adhesive tape.

Installing receiver

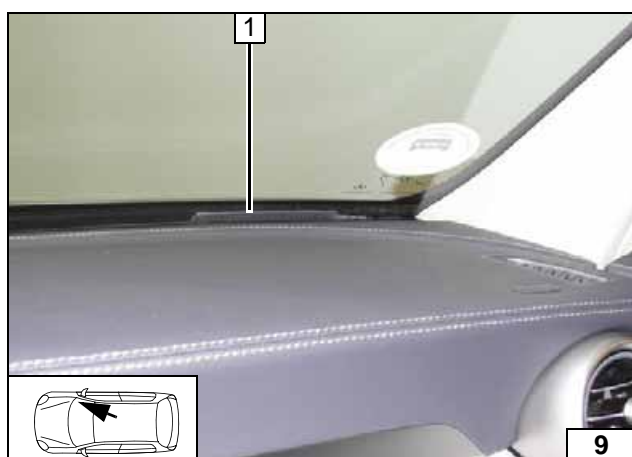

1 Aerial

Installing aerial

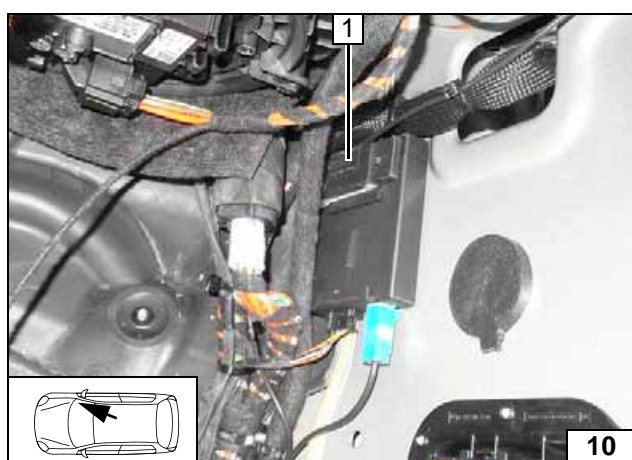

### Temperature sensor T100 HTM

Fasten temperature sensor 1 with double-sided adhesive tape.



Installing temperature sensor



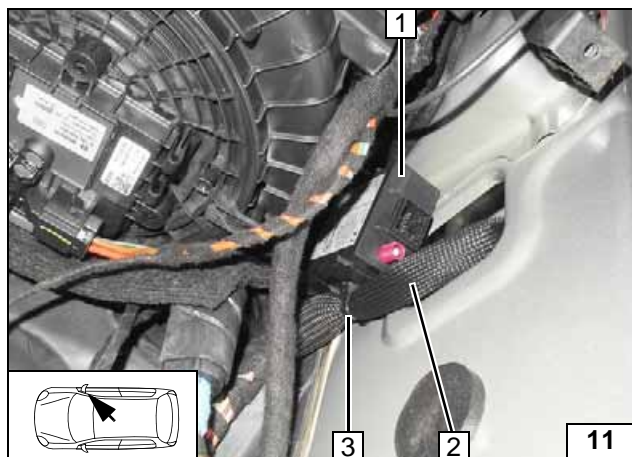

### ThermoCall Option

Fasten receiver 1 with double-sided adhesive tape and attach to original vehicle wiring harness 2 with cable tie 3.



**Installing receiver**

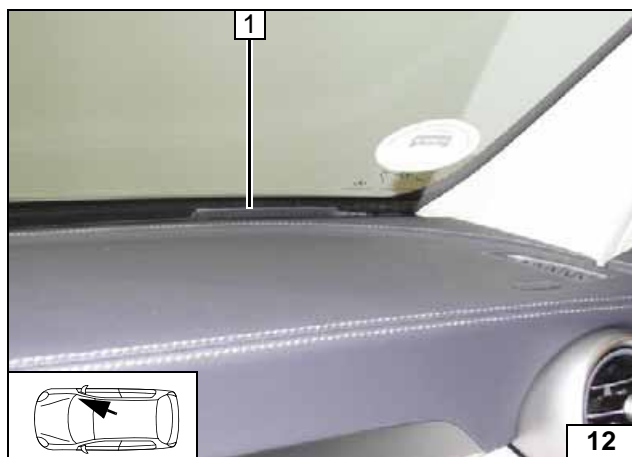

1 Aerial (optional)

**Installing aerial**

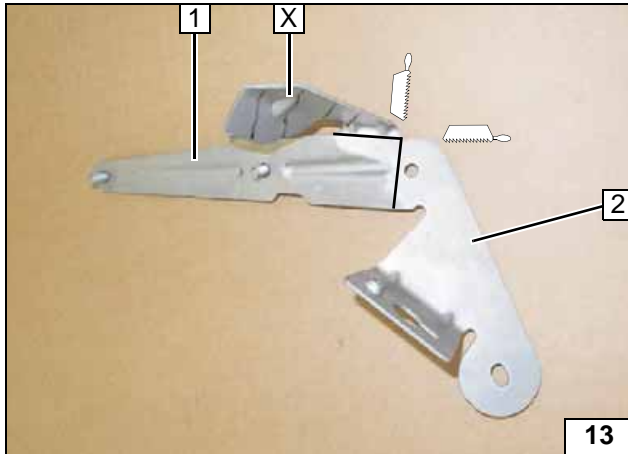
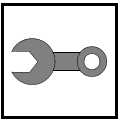

**Preparing Installation Location**

- 1 Bracket for control unit (only for vehicles with additional control unit, see next figure)
- 2 Bracket for exhaust silencer

X =

**Adapting / assigning bracket**

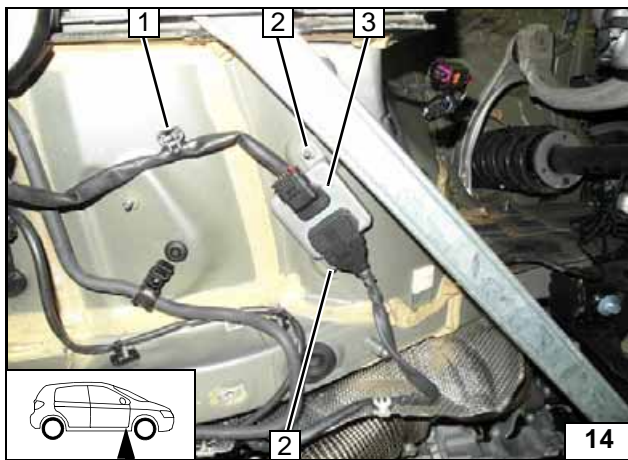

**Vehicle with additional control unit**

- 1 Detach retaining clip of stud bolt
- 2 Original vehicle nut [2x], will be re-used
- 3 Control unit

**Removing control unit**

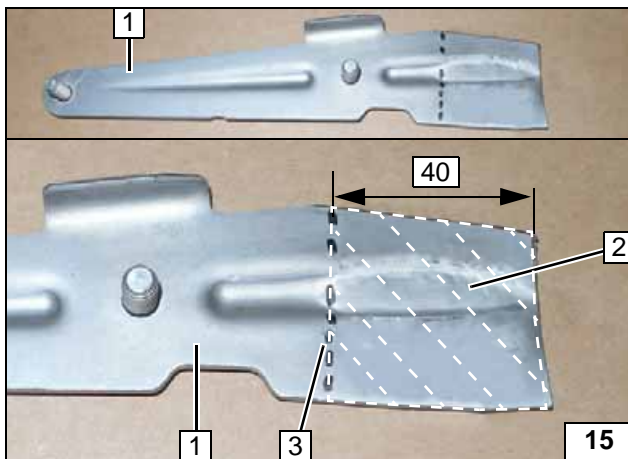

Mark bending line 3 on bracket 1. Smooth surface 2 on the right side of the bending line.

- 1 Bracket for control unit

**Preparing bracket**

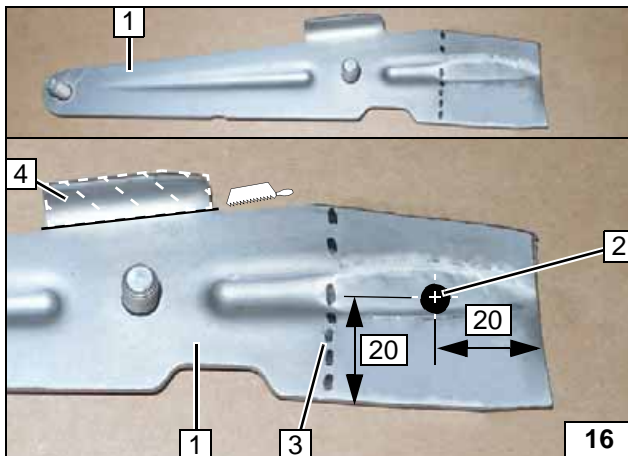

Cut off tab 4 and discard. Bend bracket 1 upwards at bending line 3 by 90° (see next figure).

- 1 Bracket for control unit
- 2 6.5 mm dia. hole

**Preparing bracket**





View of prepared bracket of control unit

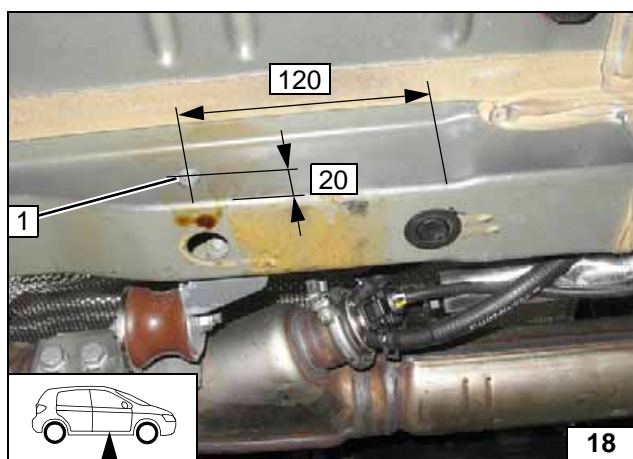

1 9.1 mm dia. hole, rivet nut

Installing rivet nut

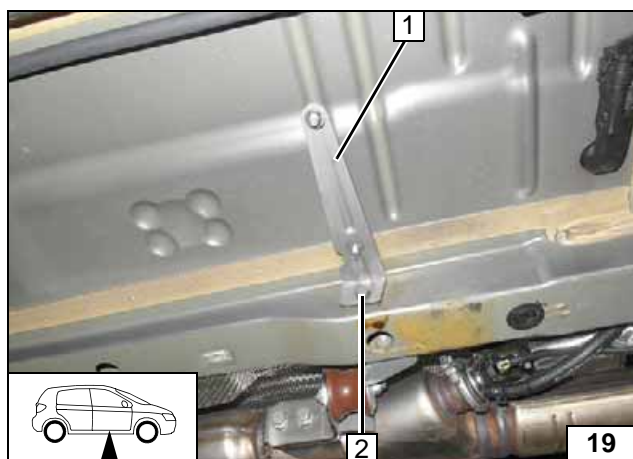

1 Bracket  
2 M6x20 bolt, spring lockwasher on rivet nut

Installing bracket

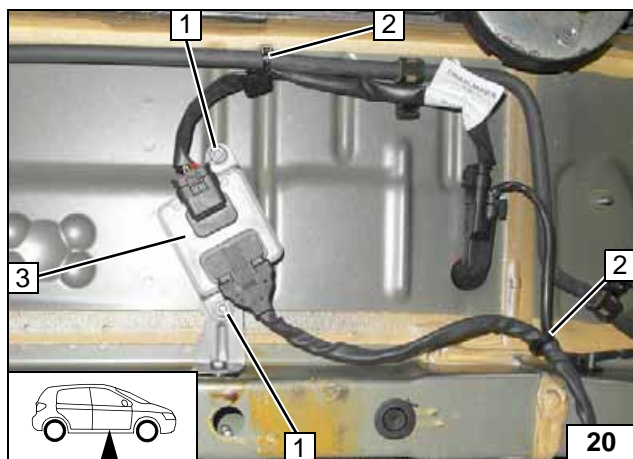

1 Original vehicle nut [2x], on stud bolt of bracket  
2 Cable tie [2x]  
3 Control unit

Installing control unit

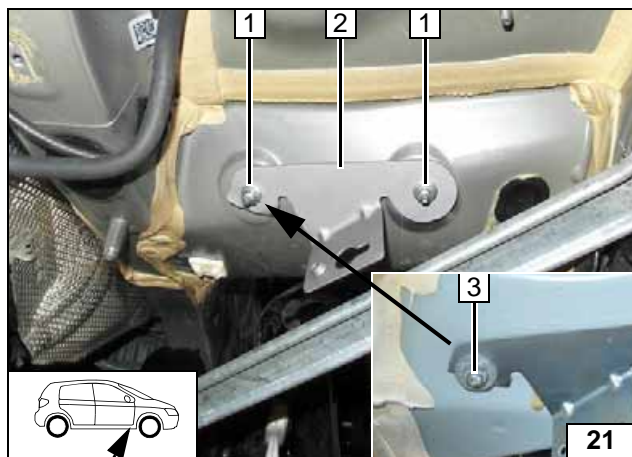

**All vehicles**

- 1 M6 flanged nut on original vehicle stud bolt [2x]
- 2 Bracket for exhaust silencer

**Shorten stud bolt at position 3 as shown.**



**Installing bracket**

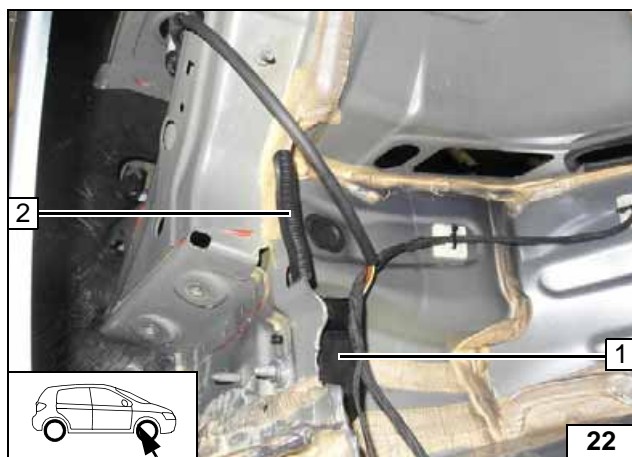

This and the following figures show a vehicle with control unit at position 1, but the instructions apply to all models!

- 2 100 mm broad edge protection



**Installing edge protection**

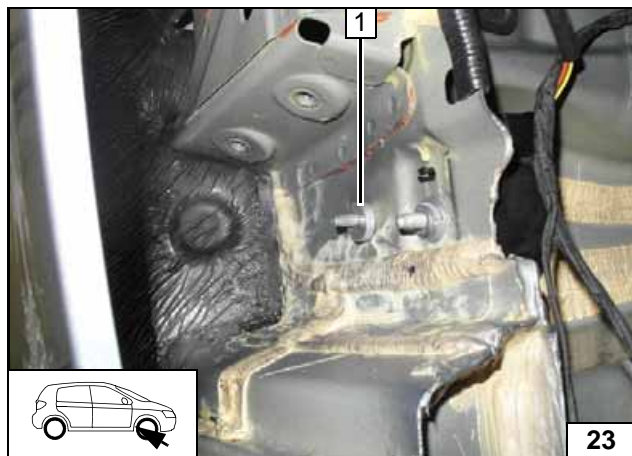

- 1 5 mm shim on original vehicle stud bolt

**Installing shim**

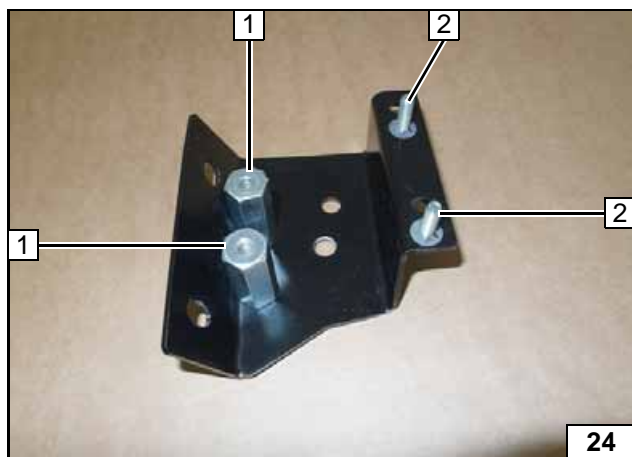

- 1 40mm spacer nut, M6x16 bolt, spring lockwasher [2x each]
- 2 M6x20 bolt, pin lock [2x each]

**Premounting basic holder**

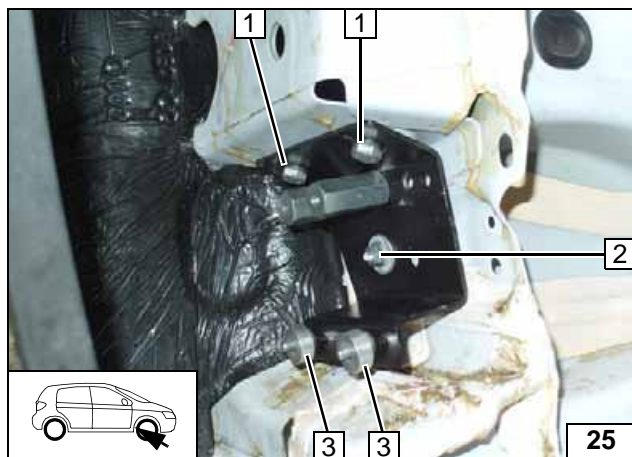

- 1 M8x20 bolt, spring lockwasher, large diameter washer [2x each] at existing threaded hole
- 2 Large diameter washer, M6 flanged nut on original vehicle stud bolt
- 3 10mm shim [2x]

**Installing basic holder**

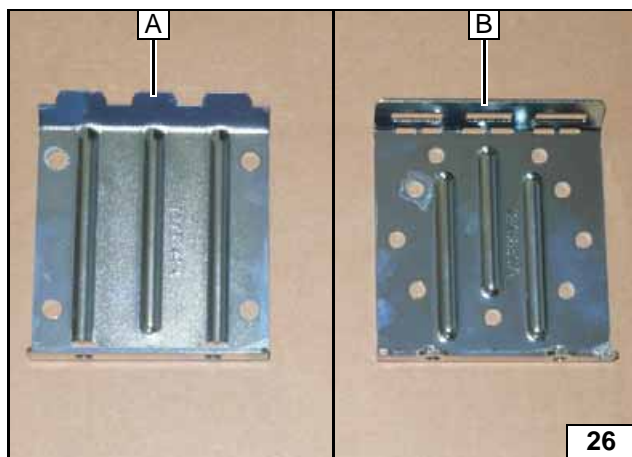

**View of/ assignment of two-part bracket**

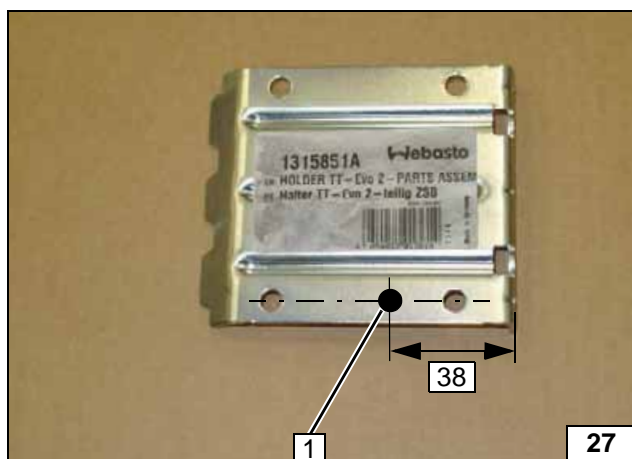

- 1 7 mm dia. hole

**Hole in bracket A**

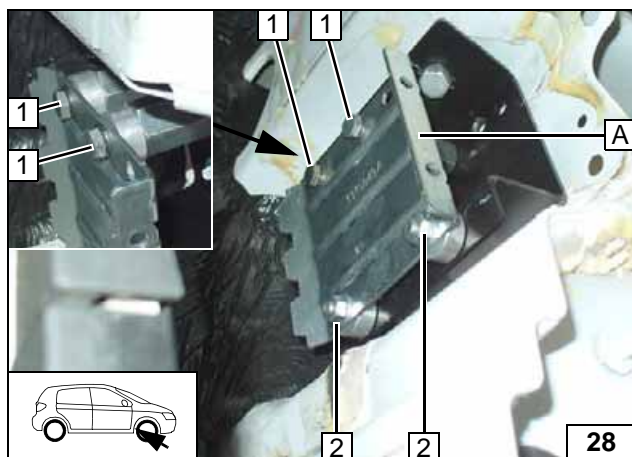

Install 10mm shim [2x] at position 1 between basic holder and bracket A.

- 1 M6x20 bolt, spring lockwasher, 10mm shim, spacer nut [2x each]
- 2 Flanged nut M6 [2x]

**Installing bracket section A**

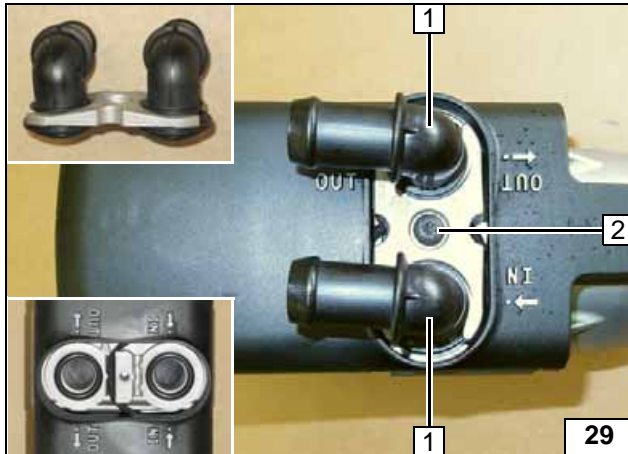
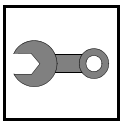

### Preparing Heater

All vehicles

- 1 Water connection piece, sealing ring [2x each]
- 2 5x15 self-tapping bolt, retaining plate of water connection piece



Installing water connection piece

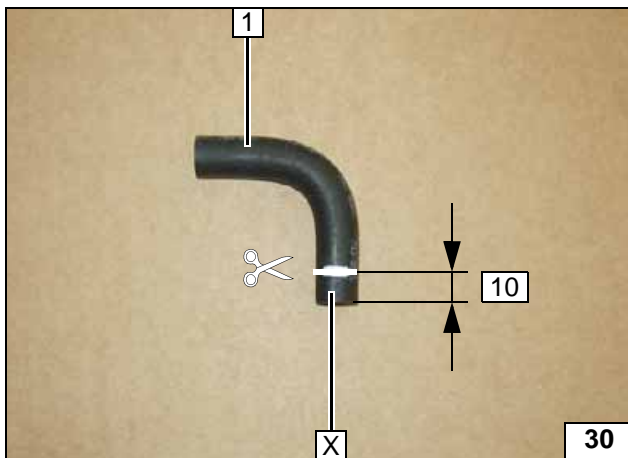

- 1 90° moulded hose

X =

Shortening moulded hose

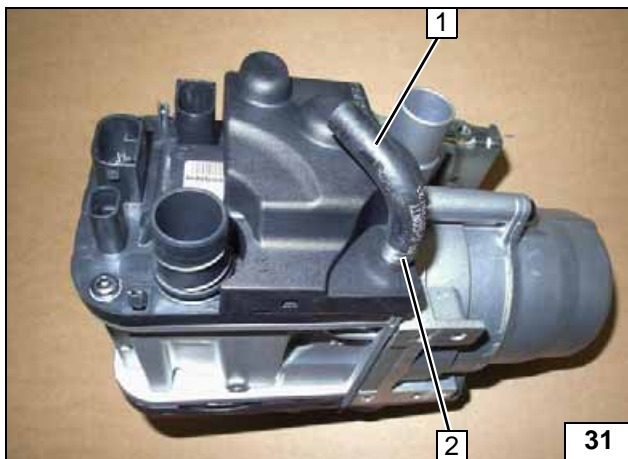

- 1 90° moulded hose (with shortened side on heater)
- 2 10 mm dia. clamp

Premounting moulded hose

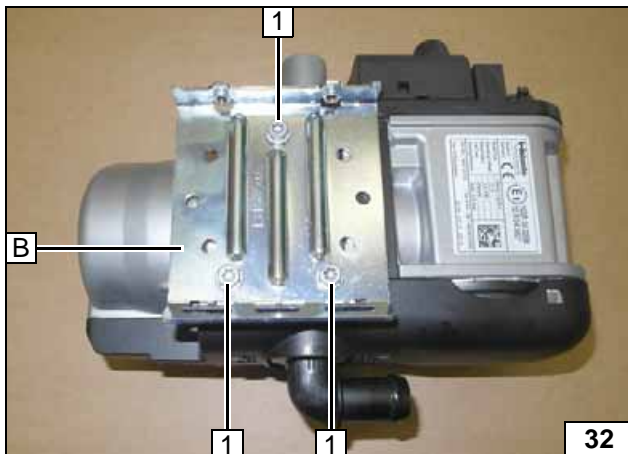

- 1 5x13 self-tapping bolt [3x]

Mounting bracket section B

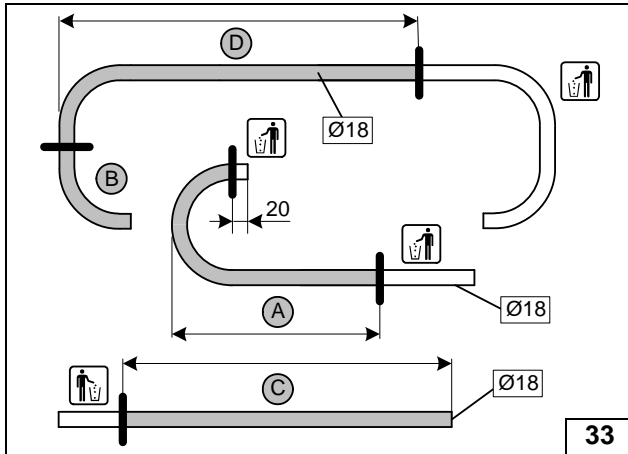
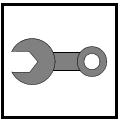

A = 400  
C = 1450  
D = 1350

**Cutting hoses to length**

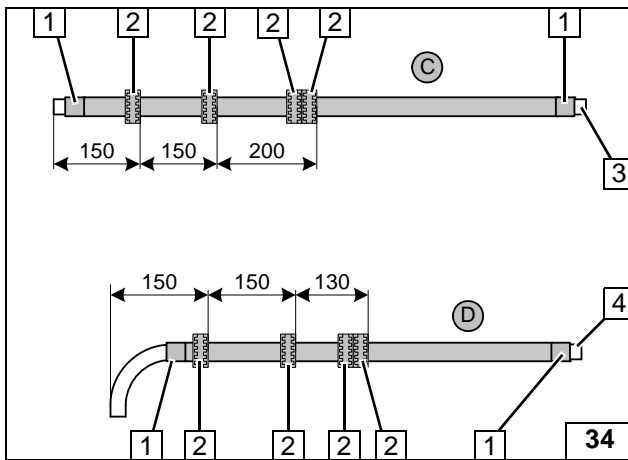

Push braided protection hoses onto hoses **C** and **D** and cut to length. Cut heat shrink plastic tubing to size.



- 1 50 mm long heat shrink plastic tubing [4x]
- 2 Position black rubber isolator [8x]
- 3 Connection side of heater inlet
- 4 Connection side of heater outlet

**Preparing hoses**

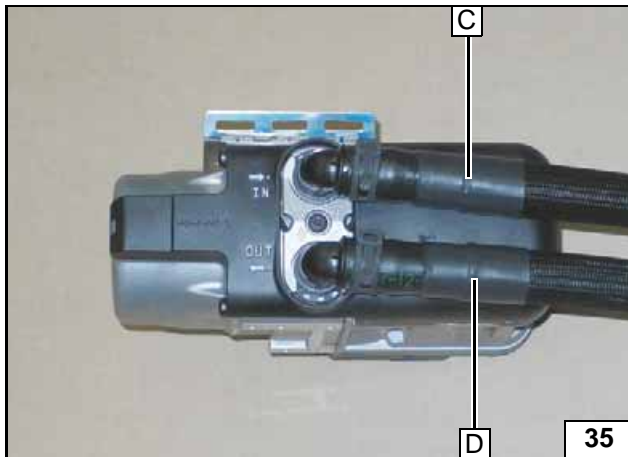

All spring clips = 25 mm dia.



**Installing hoses**

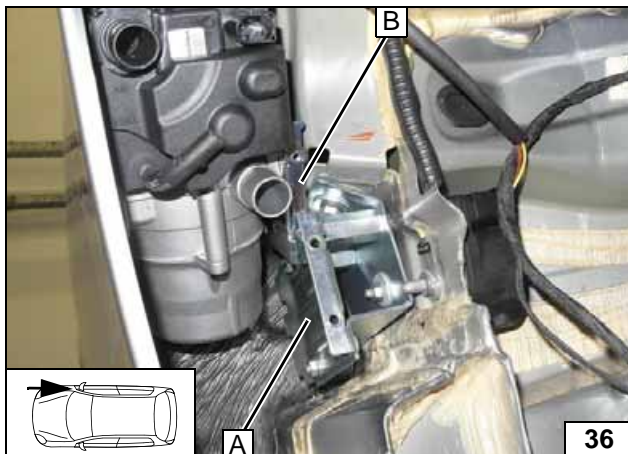

**Installing Heater**

Install heater in installation location from above (see next figure).



**Installing heater**

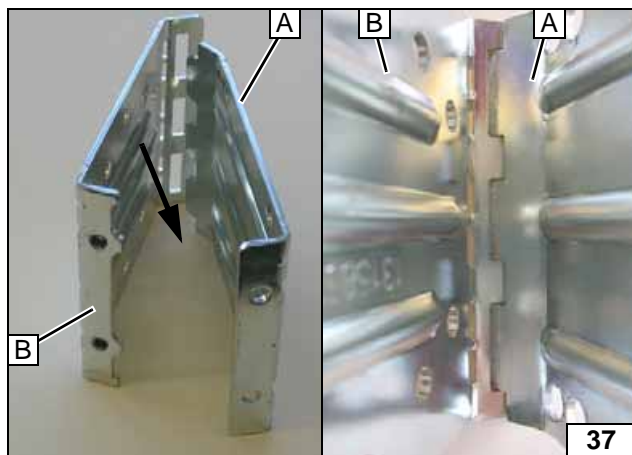

The recesses of bracket **B** must be guided over the tabs of bracket **A**.



- A** Bracket (installed on basic holder)
- B** Bracket (installed on heater)

View of bracket **A** and **B** assembly

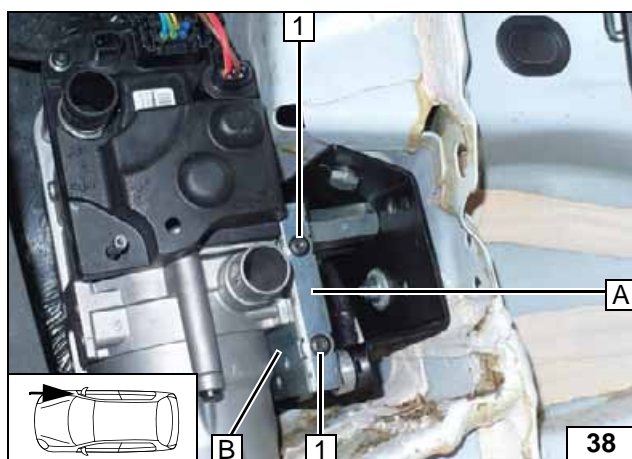

Check the assembly of bracket **B** and bracket **A**, then screw them together.



- 1** M5x12 torx screw [2x]

Installing heater

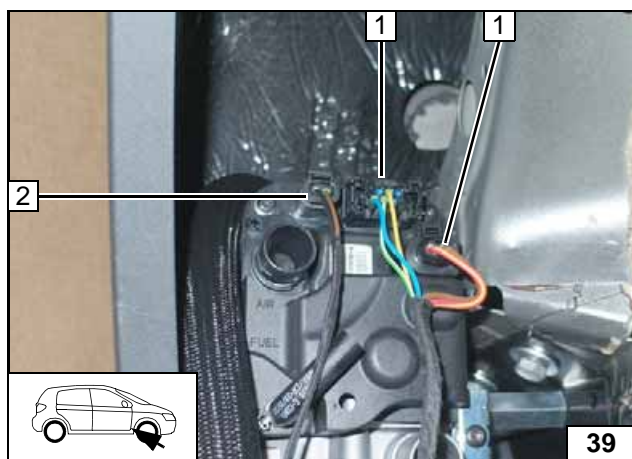

- 1** Heater wiring harness connector [2x]
- 2** Connector of circulating pump wiring harness

Installing heater



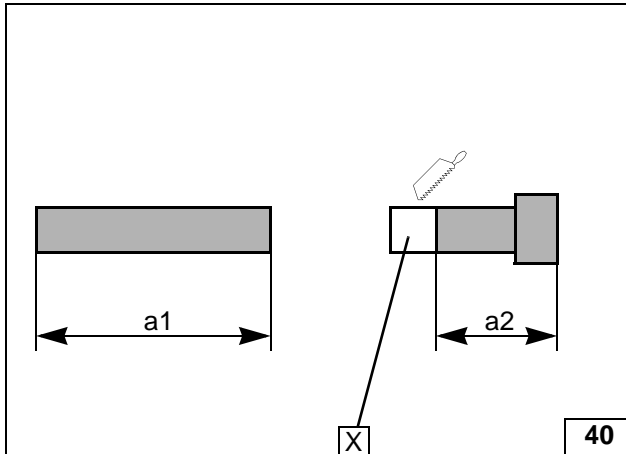
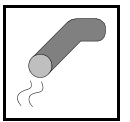

**Exhaust Gas**

a1 = 230  
a2 = 90

X =

**Preparing exhaust pipe**

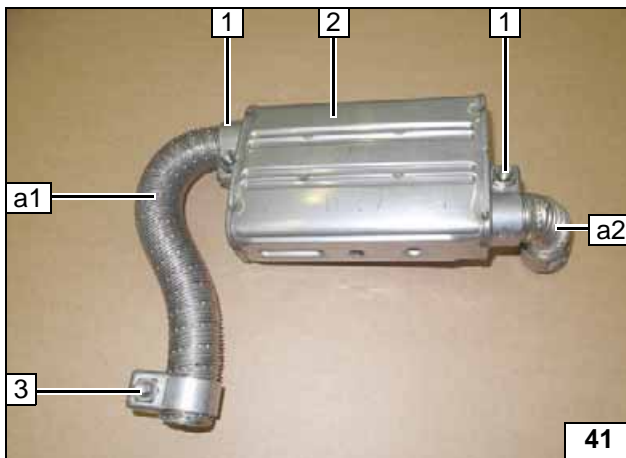

Shape exhaust pipe **a1** and **a2** as shown.



- 1 Hose clamp [2x]
- 2 Silencer
- 3 Hose clamp, loosely installed

**Premounting silencer**

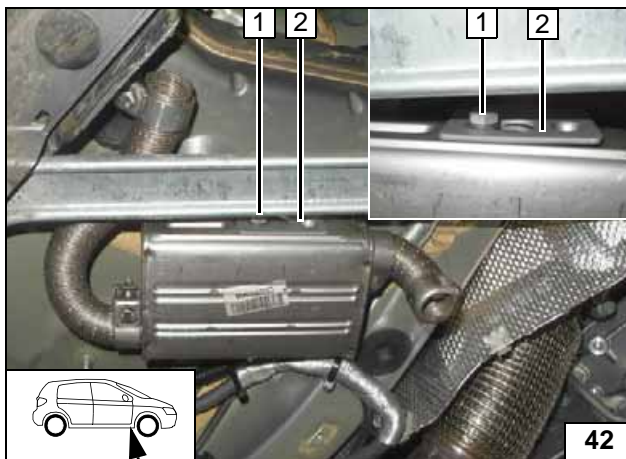

- 1 M6x16 bolt, spring lockwasher
- 2 Bracket of exhaust system

**Installing silencer**

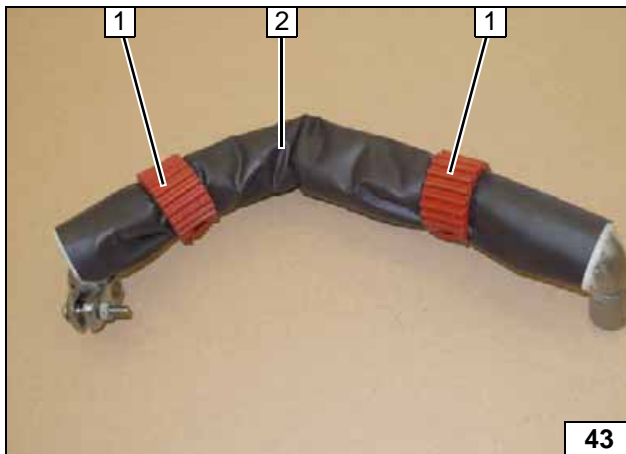

Turn locking device of silicone band **1** [2x] as shown.



- 2 Complete exhaust tube

**Checking exhaust tube**

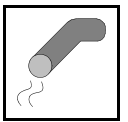

1 Tighten hose clamp



Installing exhaust tube

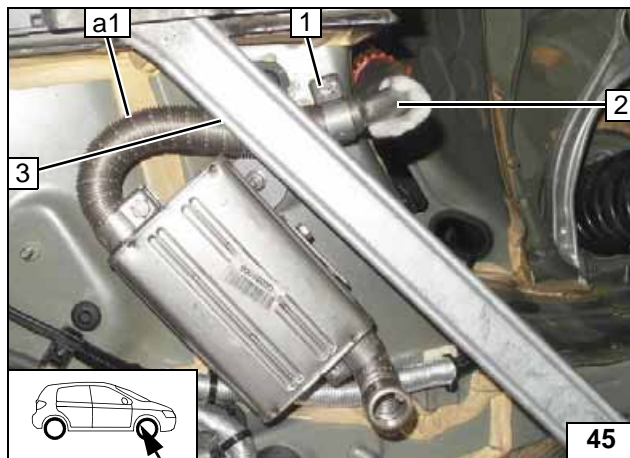

Check that there is freedom of movement between exhaust pipe a1 and cross member at position 3, correct if necessary.



- 1 Tighten hose clamp
- 2 Exhaust tube

Connecting exhaust tube and exhaust pipe a1

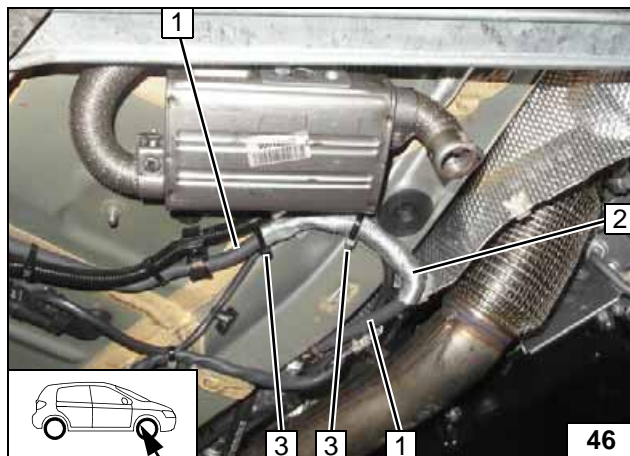

Only for vehicles with additional line (depends on the equipment) 1!



Slit 300mm, 14.5mm dia. heat protection hose 2 lengthwise, slide it over original vehicle line 1 and secure with cable tie 3 [2x].

Installing heat protection hose



**Coolant Circuit**





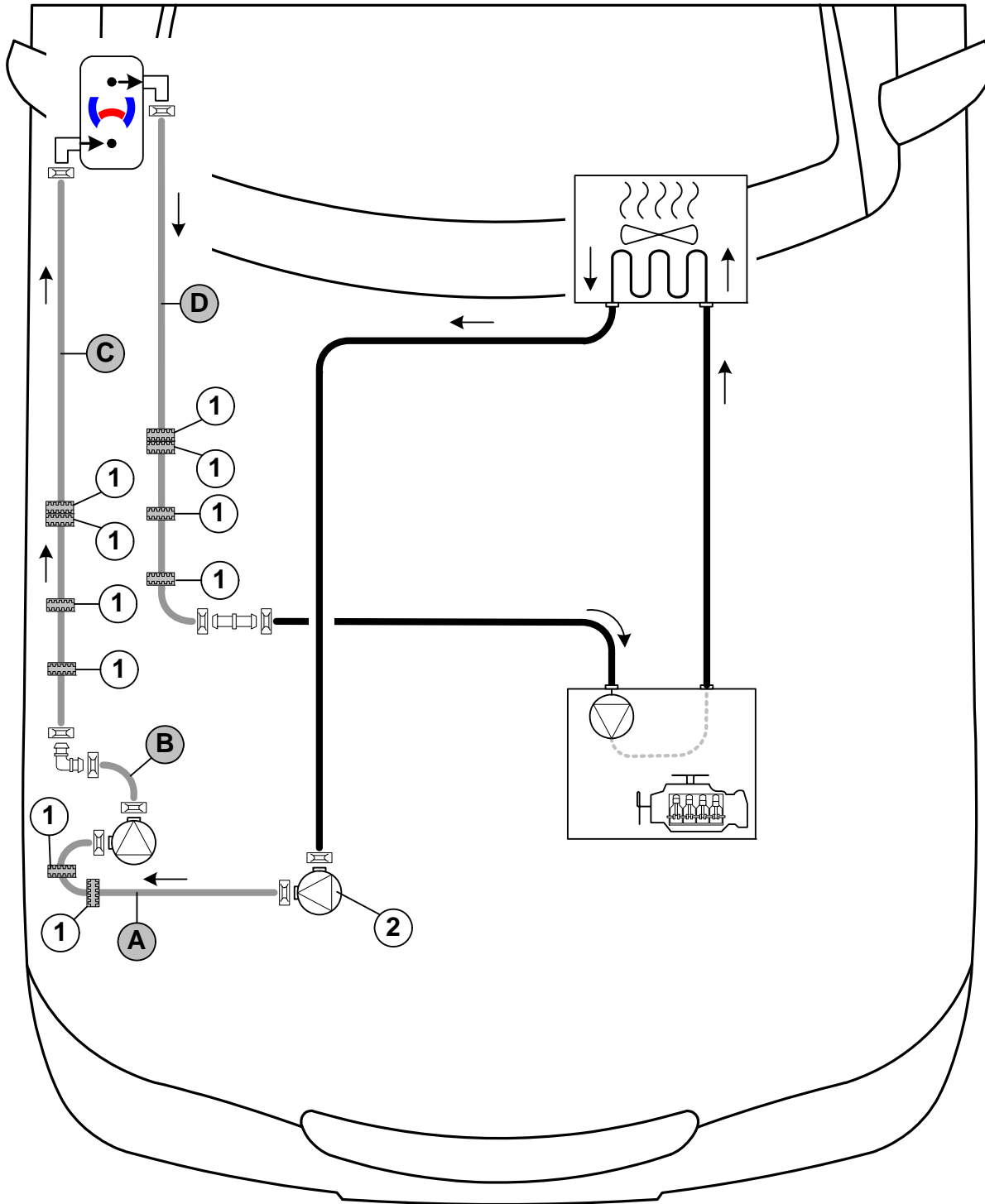

Any coolant running off should be collected in an appropriate container. Route hoses kink-free. Unless specified otherwise, always fasten using cable ties. Position clamps so that other hoses cannot be damaged. The heater must be filled with coolant when installing the hoses.

The connection should be modelled on an 'inline' circuit and based on the following diagram:



Hose routing diagram

All spring clips without a specific designation  = 25 mm dia.  
 All connecting pipes without a specific designation  and  = 18x18 mm dia.  
 1 = Black (sw) rubber isolator .  
 2 = Original vehicle residual heat pump



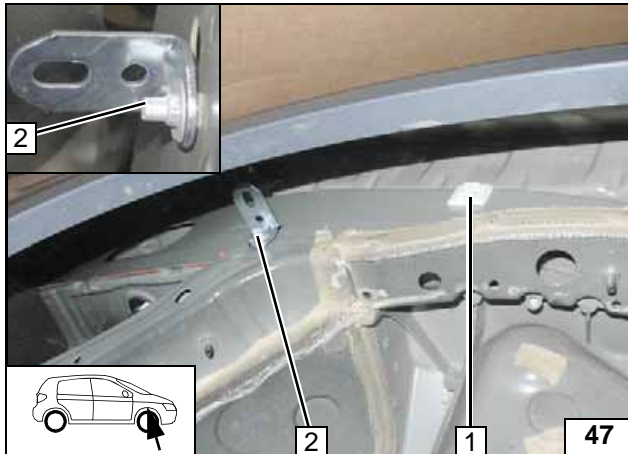

- 1 Self-adhesive socket
- 2 Plate nut, angle bracket, original vehicle stud bolt

Aligning clamp

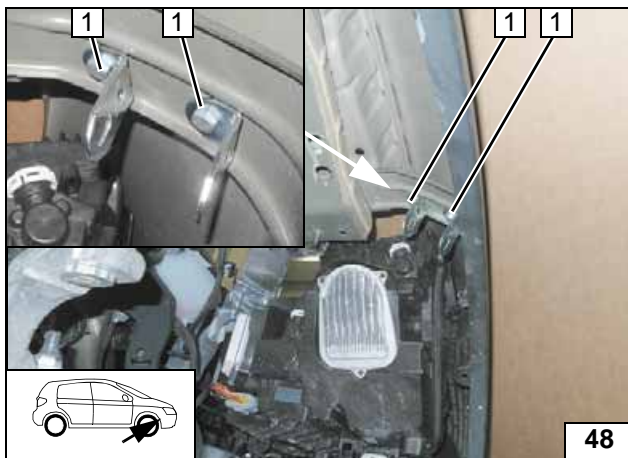

- 1 M6x12 bolt, angle bracket, existing hole, flanged nut [2x each]

Installing angle bracket

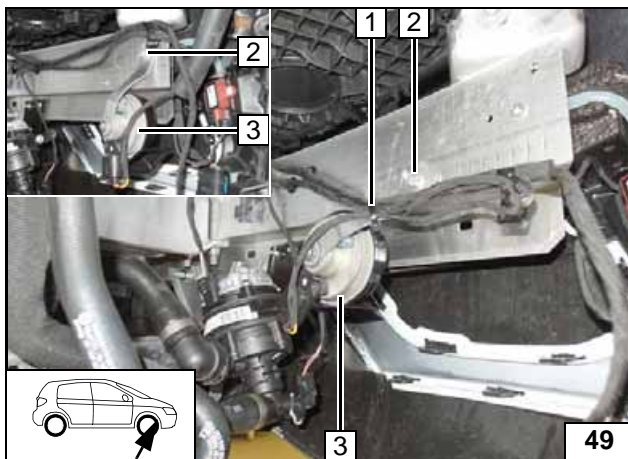

- 1 Cable tie
- 2 Original vehicle bolt on original vehicle threaded hole
- 3 Horn

Moving horn

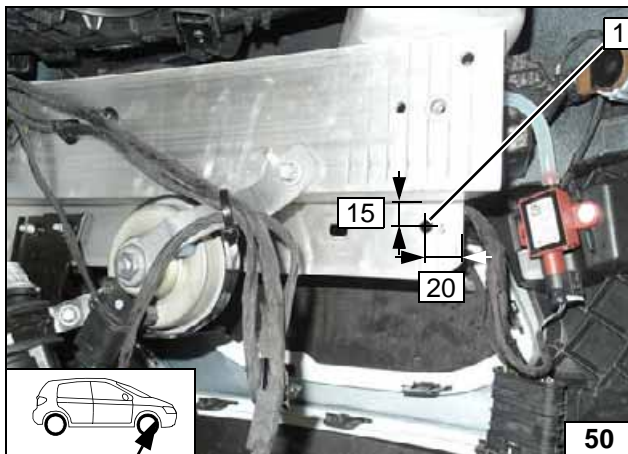

- 1 7 mm dia. hole

Drilling hole

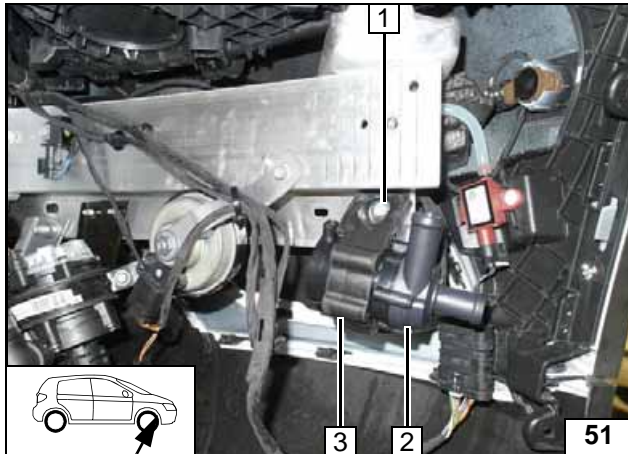

- 1 M6x25 bolt, flanged nut
- 2 Circulating pump
- 3 Circulating pump mount

**Installing circulating pump**

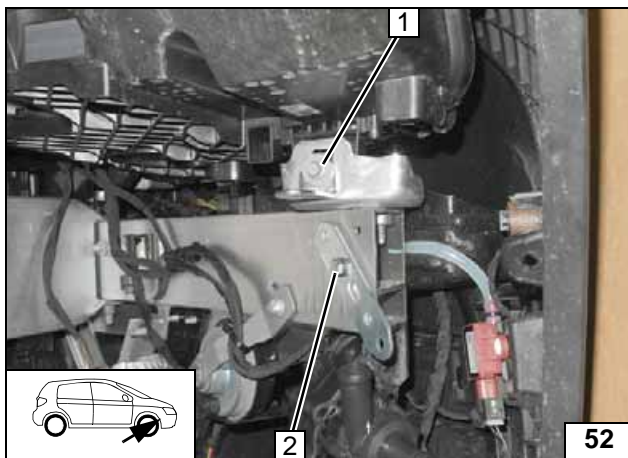

- 1 Original vehicle bolt, angle bracket
- 2 M6x20 bolt, spring lockwasher, perforated bracket

**Installing angle bracket and perforated bracket**

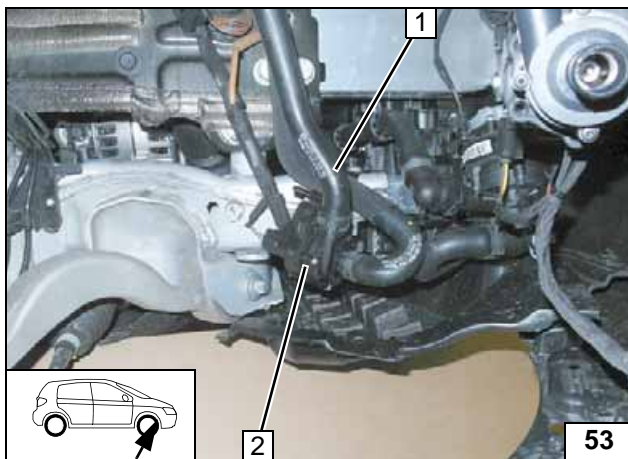

Disconnect original vehicle hose of engine inlet / residual heat pump 1. Spring clip will be reused.

- 2 Residual heat pump



**Cutting point**

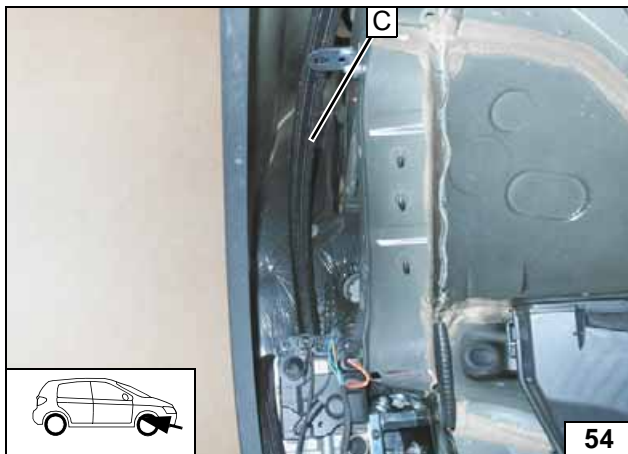

Route hose C in wheel well forwards.



**Routing of hose C in wheel well**

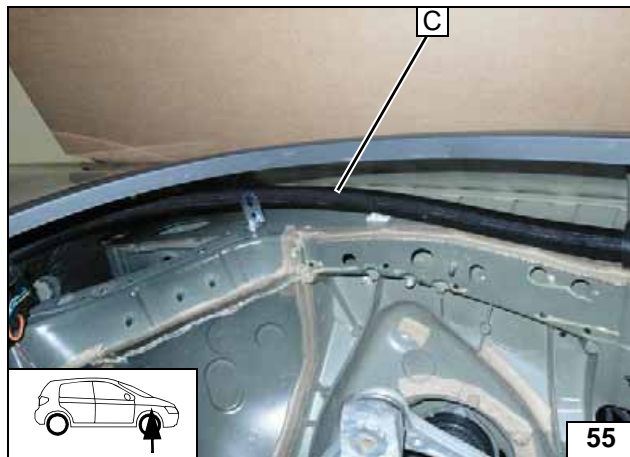
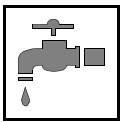

Route hose **C** in wheel well forwards.



**Routing of hose C in wheel well**

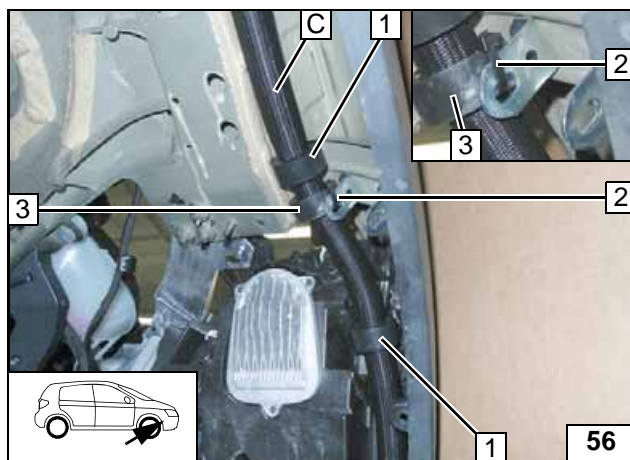

Fasten black (sw) rubber isolator **3** to the angle bracket on the inside using cable tie **2**.



- 1 Align black (sw) rubber isolator [2x]

**Hose C in wheel well**

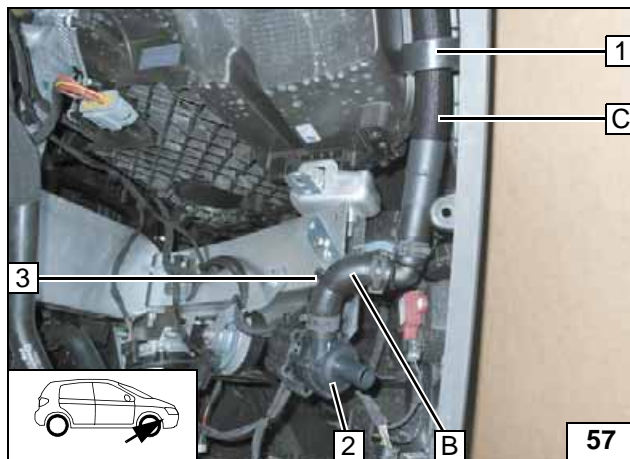

Fasten hose **B** to perforated bracket using cable tie **3**.



- 1 Align black (sw) rubber isolator
- 2 Circulating pump

**Connecting circulating pump outlet**

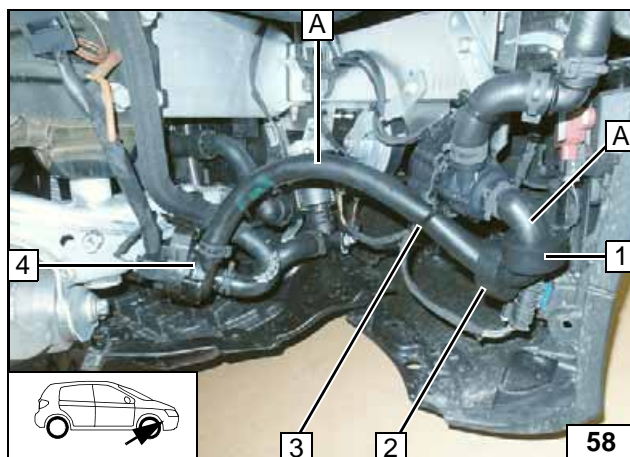

Fasten hose **A** to circulating pump mount using cable tie **3**.



- 1 Align black (sw) rubber isolator
- 2 Align black (sw) rubber isolator with original vehicle connector
- 4 Residual heat pump outlet connection piece

**Installing hose A**

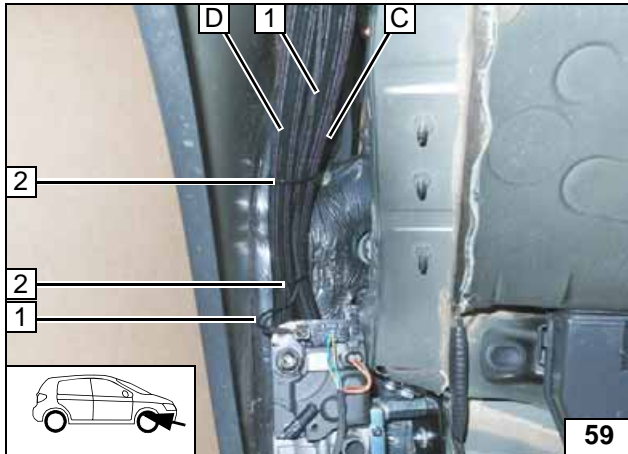

Route hose **D** and circulating pump wiring harness **1** in the wheel well to the front.



- 2 Cable tie [2x]

Hose **D** in wheel well

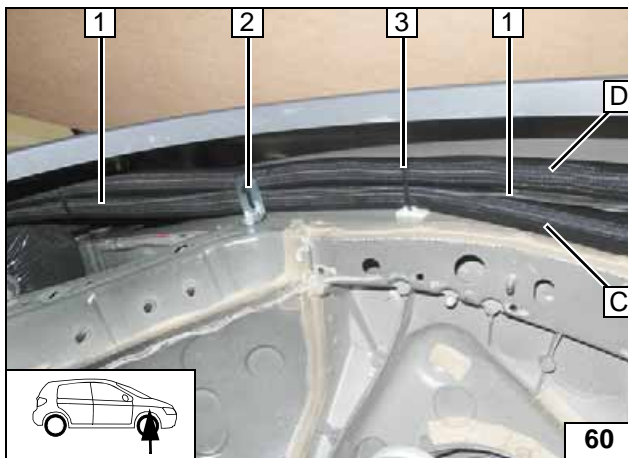

Route hose **D** and circulating pump wiring harness **1** in the wheel well to the front.



- 2 Cable tie on angle bracket
- 3 Cable tie on adhesive base

Routing of hose **D** in wheel well

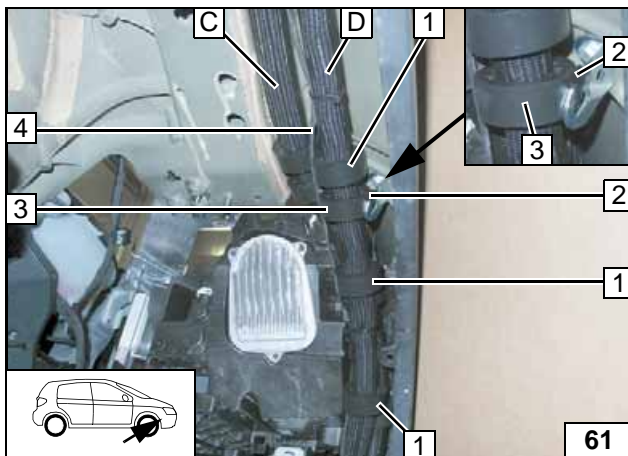

Fasten black (sw) rubber isolator **3** to the angle bracket on the outside using cable tie **2**.



- 1 Align black (sw) rubber isolator [3x]
- 4 Circulating pump wiring harness

Routing of hose **D** in wheel well

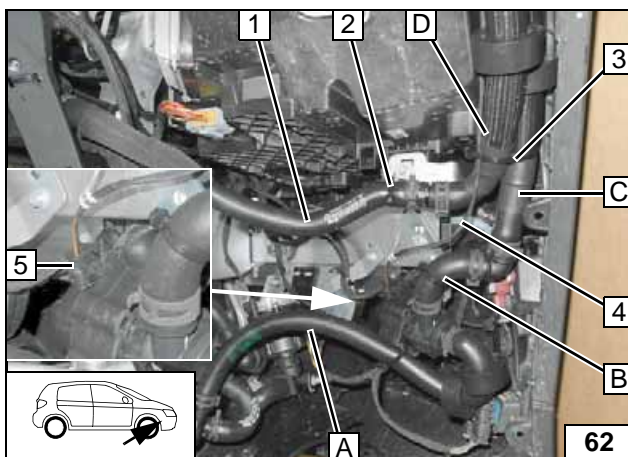

Fasten engine inlet hose **1** to pre-mounted angle bracket using cable tie **2**.



- 3 Cable tie
- 4 Circulating pump wiring harness
- 5 Connector of circulating pump wiring harness

Connection on engine inlet

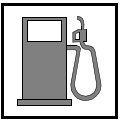

**Fuel**



Open the vehicle's fuel tank cap, ventilate the tank and then re-close the tank lock.

Catch any fuel running off in an appropriate container.

Route fuel line and metering pump wiring harness so that they are protected against stone impact. Unless specified otherwise, always fasten using cable ties.



Provide rub protection for fuel line and wiring harness in areas where there are sharp edges.

The fuel line and wiring harness are routed to the metering pump as shown in the wiring harness routing diagram.

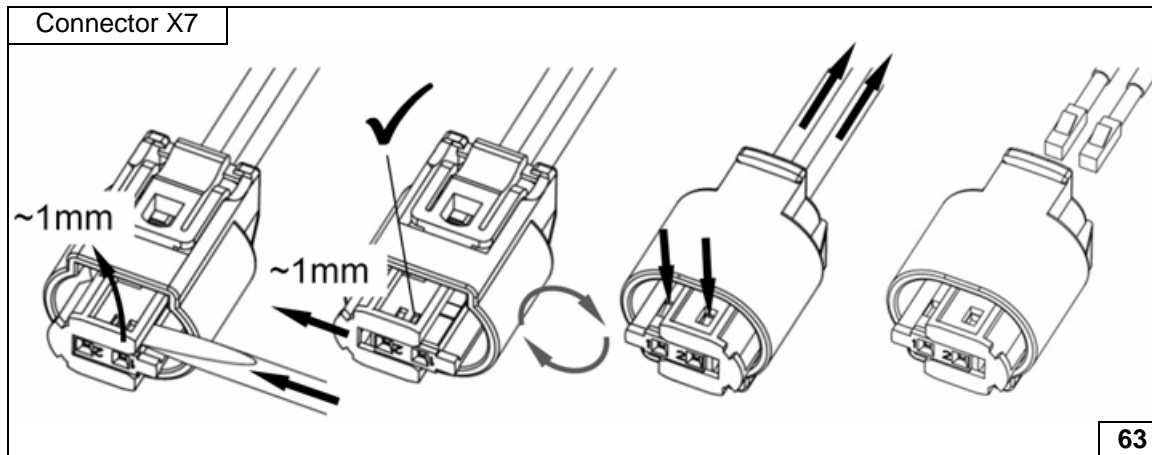

**Dismantling metering pump connector**

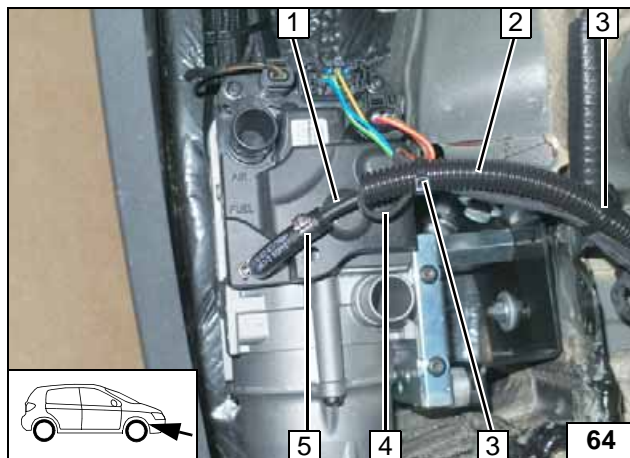

Cut fuel line to length by 1,200mm, this will be required for the connection of the FuelFix. Pull fuel line 1 and metering pump wiring harness 4 into 10 mm dia. corrugated tube 2.

- 3 Cable tie [2x]
- 5 10 mm dia. clamp

**Connect-  
ing heater**

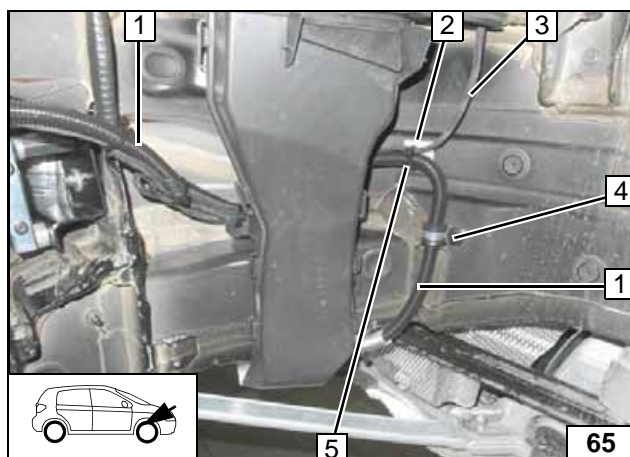

Degrease bonding surfaces at position 2.

- 1 Fuel line and metering pump wiring harness in 10 mm dia. corrugated tube
- 2 Adhesive base
- 3 Heater wiring harness
- 4 15mm dia. rubber-coated p-clamp, plastic nut, original vehicle stud bolt
- 5 Cable tie

**Routing  
lines**



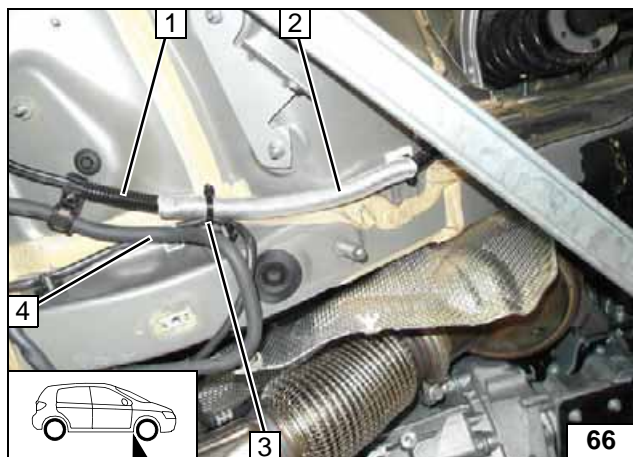

Slide 300 mm, 14.5 mm dia. heat protection hose **2** onto 10 mm dia. corrugated tube **1** and secure with cable tie **3**.



**4** Additional line (depends on the equipment)

**Routing lines**

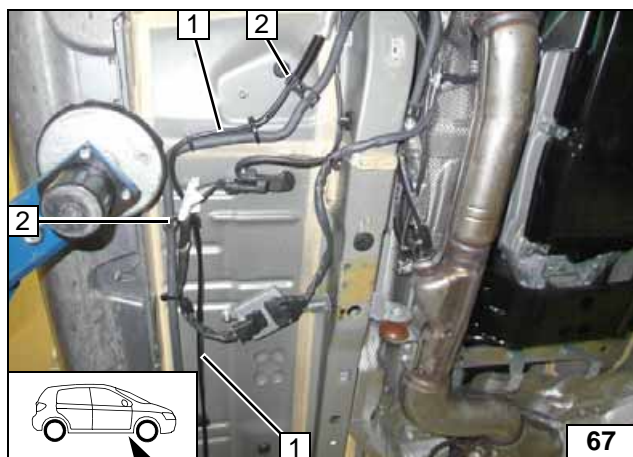

Insert fuel line and metering pump wiring harness **1** in original vehicle line holder **2**.



**Routing lines**

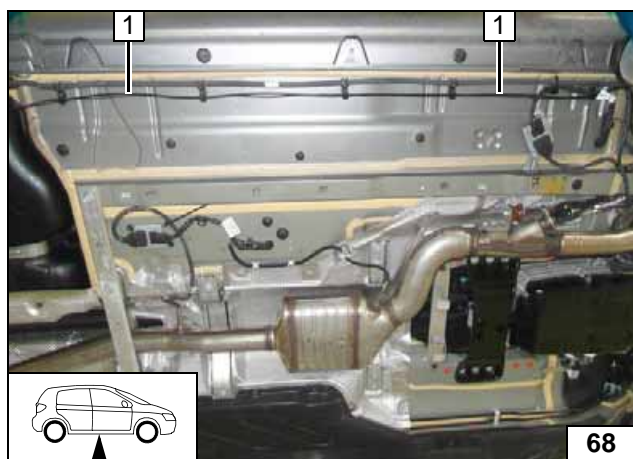

Route fuel line and metering pump wiring harness **1** along original vehicle line holder to the installation location of the metering pump.



**Routing lines**

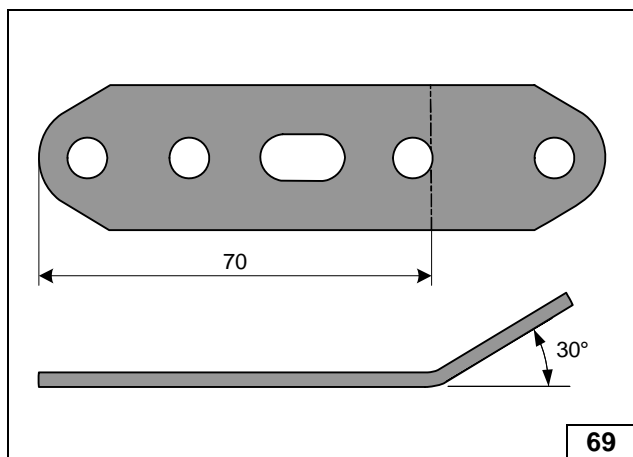

**Angling down perforated bracket**

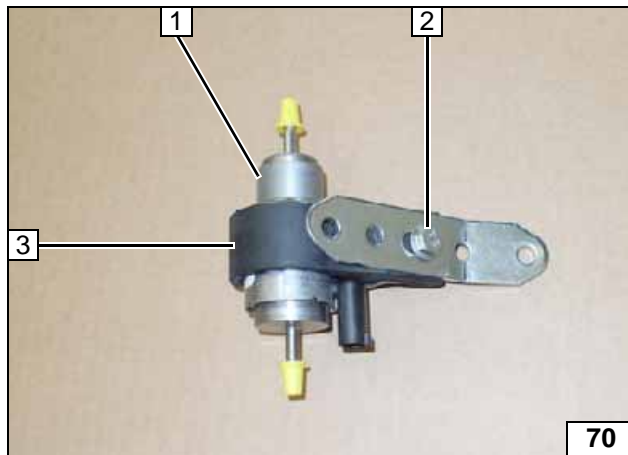

- 1 Metering pump
- 2 M6x25 bolt, support angle bracket, flanged nut
- 3 Metering pump mount

Premounting metering pump

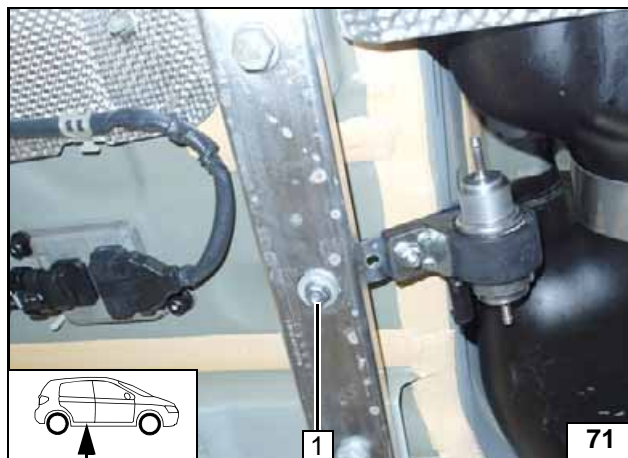

- 1 M6x30 bolt, original vehicle hole, large diameter washer [2x], flanged nut

Installing metering pump

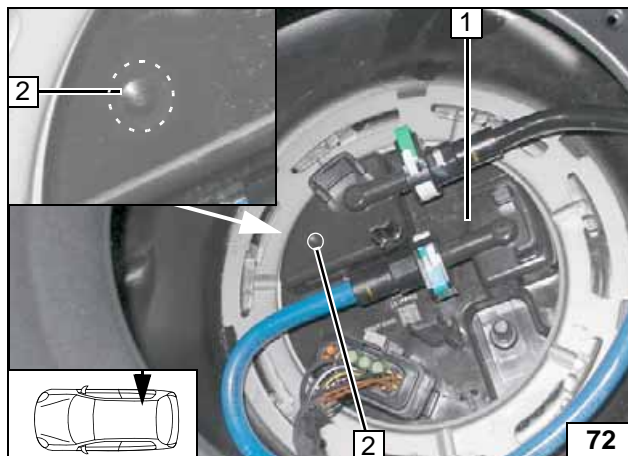

### Installing FuelFix

Work steps F1 and F2.

- 1 Fuel tank sending unit
- 2 Hole pattern corresponds to existing embossing



Copying hole pattern

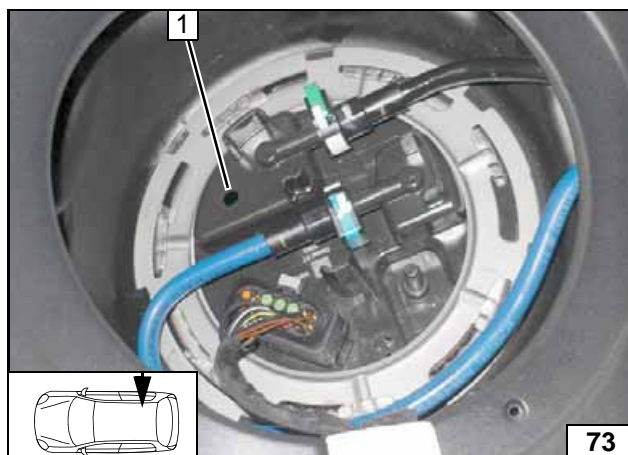

Work step F3.

- 1 Hole made with provided drill

Hole for FuelFix

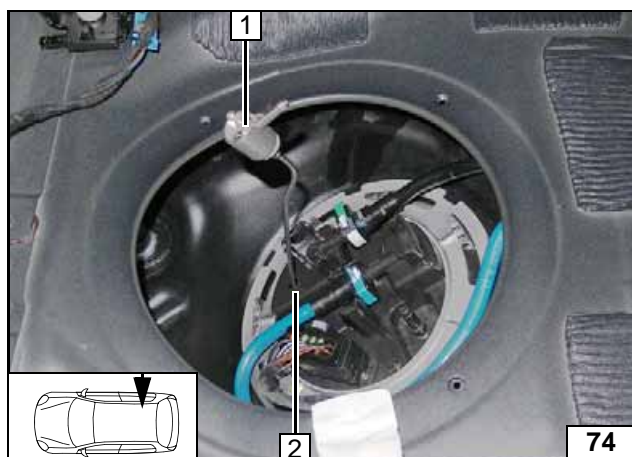

Work steps F4 and F5.

Bend FuelFix 1 according to template and cut to length.  
Insert into hole 2.



**Inserting FuelFix**

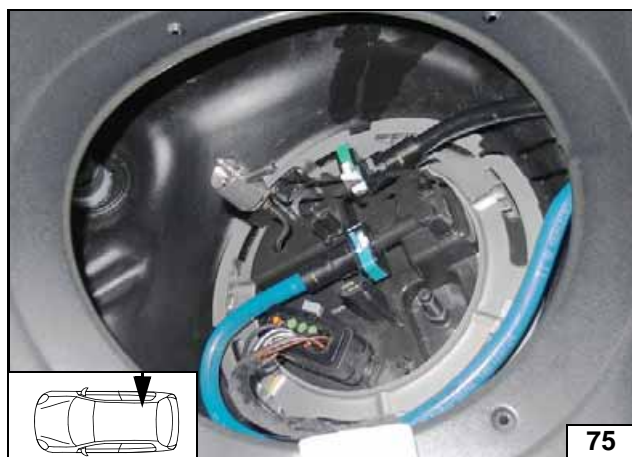

**Inserting FuelFix**

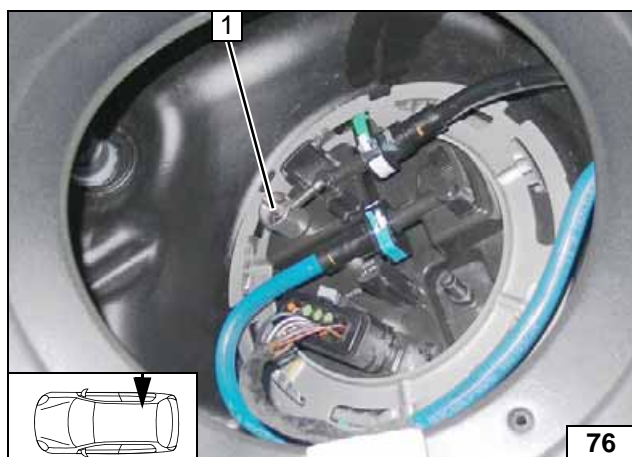

Work steps F5.3 and F5.4.

Align FuelFix 1 as shown.



**Aligning FuelFix**

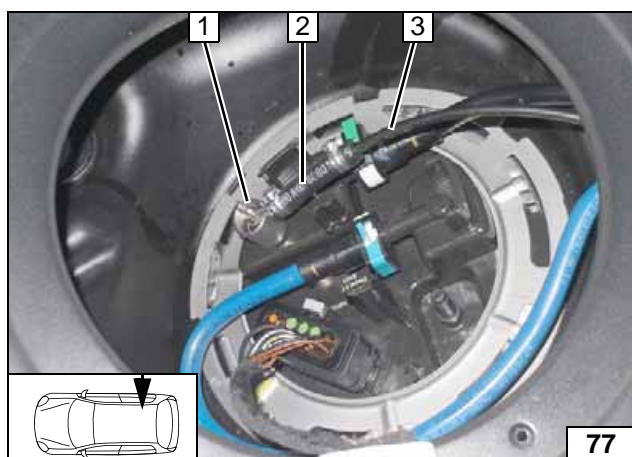

Work step F6.

- 1 FuelFix
- 2 Hose section, 10mm dia. clamp [2x]
- 3 1200mm long fuel line

**Connect-  
ing fuel line**

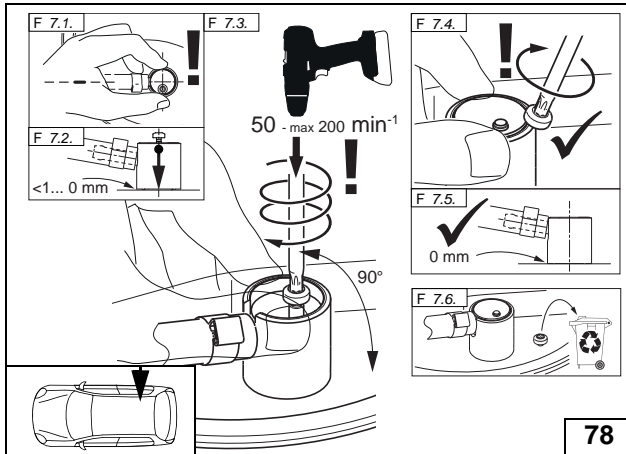

Work step F7.



Installing FuelFix



Work step F8.

Checking firm seating of FuelFix

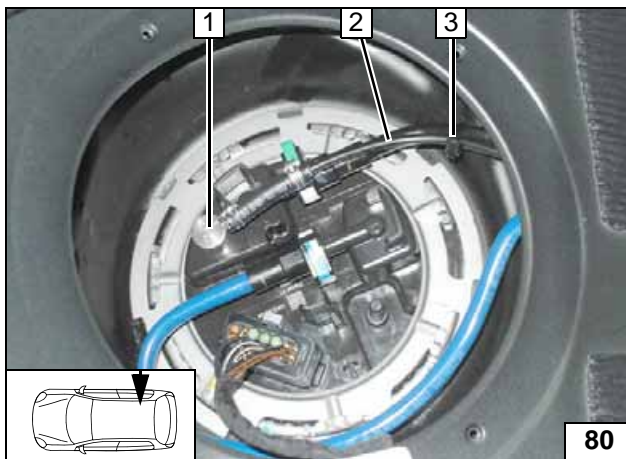

- 1 FuelFix installed
- 2 Fuel line of FuelFix
- 3 Cable tie as tension relief

Securing fuel line

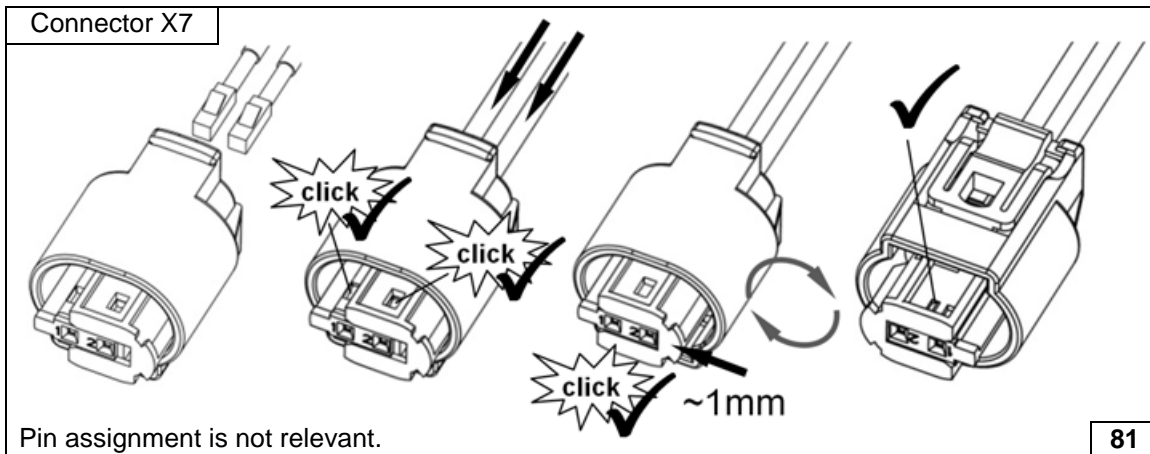

Pin assignment is not relevant.

Completing metering pump connector

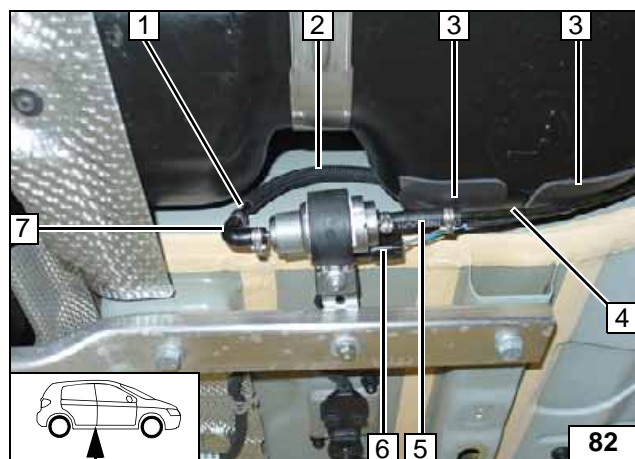

Ensure sufficient distance from neighbouring components, correct if necessary. Slide 6x11 fabric protective hose **2** onto fuel line of FuelFix **1**.



- 3** Insulation strips [2x]
- 4** Heater fuel line
- 5** Hose section, 10mm dia. clamp [2x]
- 6** Metering pump wiring harness, connector X7 mounted
- 7** 90° moulded hose, 10mm dia. clamp [2x]

**Connect-  
ing meter-  
ing pump**

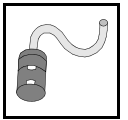

## Combustion Air

- 1 Insulation protection strips

Sticking on insulation protection strips



- 1 Combustion air pipe



Installing combustion air pipe

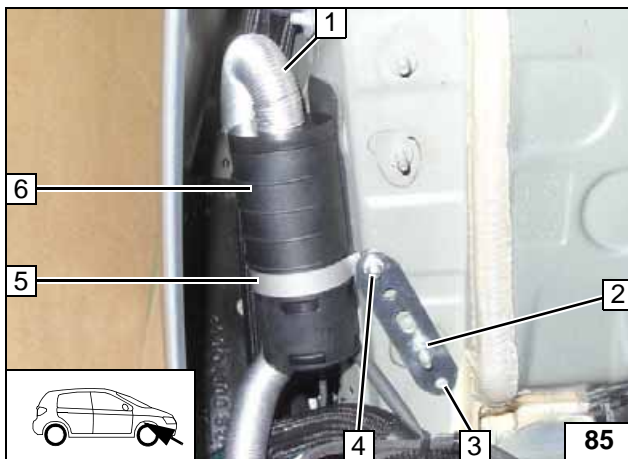

- 1 Combustion air pipe
- 2 M6 flanged nut on original vehicle stud bolt
- 3 Perforated bracket
- 4 M5x16 bolt, flanged nut
- 5 51 mm dia. clamp
- 6 Silencer



Installing silencer

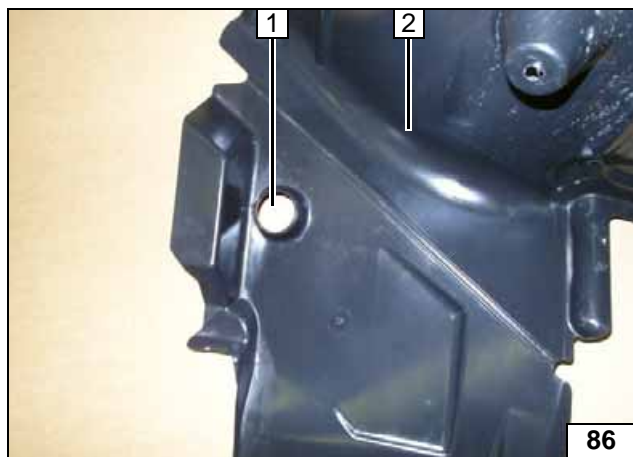

**Final Work**

Drill out existing opening in position 1 to 60 mm dia.

2 Rear section of the wheel well trim



**Hole for ex-  
haust pipe  
a2**

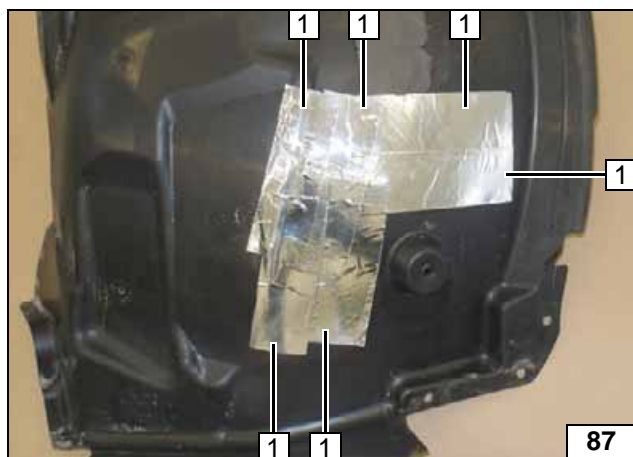

Cut heat protection strip 1 in half and stick on as shown.



**Sticking on  
heat protec-  
tion strip**

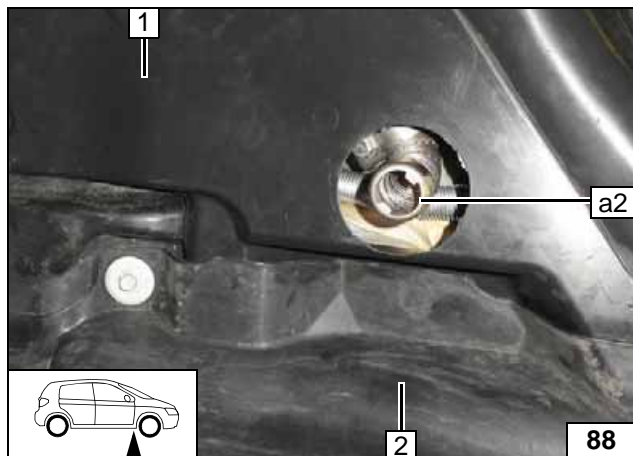

Ensure sufficient distance from neighbouring components, correct if necessary. Install wheel well trim 1. Align exhaust pipe a2 with the centre of the hole and flush with wheel well trim 1.



**Installing  
underride  
protection**

2 Underride protection



Reassemble the components in reverse order. Check all hoses, clamps and all electrical connections for firm seating. Insulate and tie back loose lines.

Only use manufacturer-approved coolant. Spray the heater components with anti-corrosion wax (Tectyl 100K).

- **Connect the battery.**
- **Fill and bleed the coolant circuit according to the vehicle manufacturer's instructions.**
- **Teach Telestart transmitter**
- **For initial startup and function check, please see installation instructions.**
- **For the settings of the A/C control panel see the installation documentation in the additional kit 'Webasto Comfort' A/C control section 'Final Work'**
- **Place the 'Switch off parking heater before refuelling' caution label near the filler neck.**







### FuelFix Template

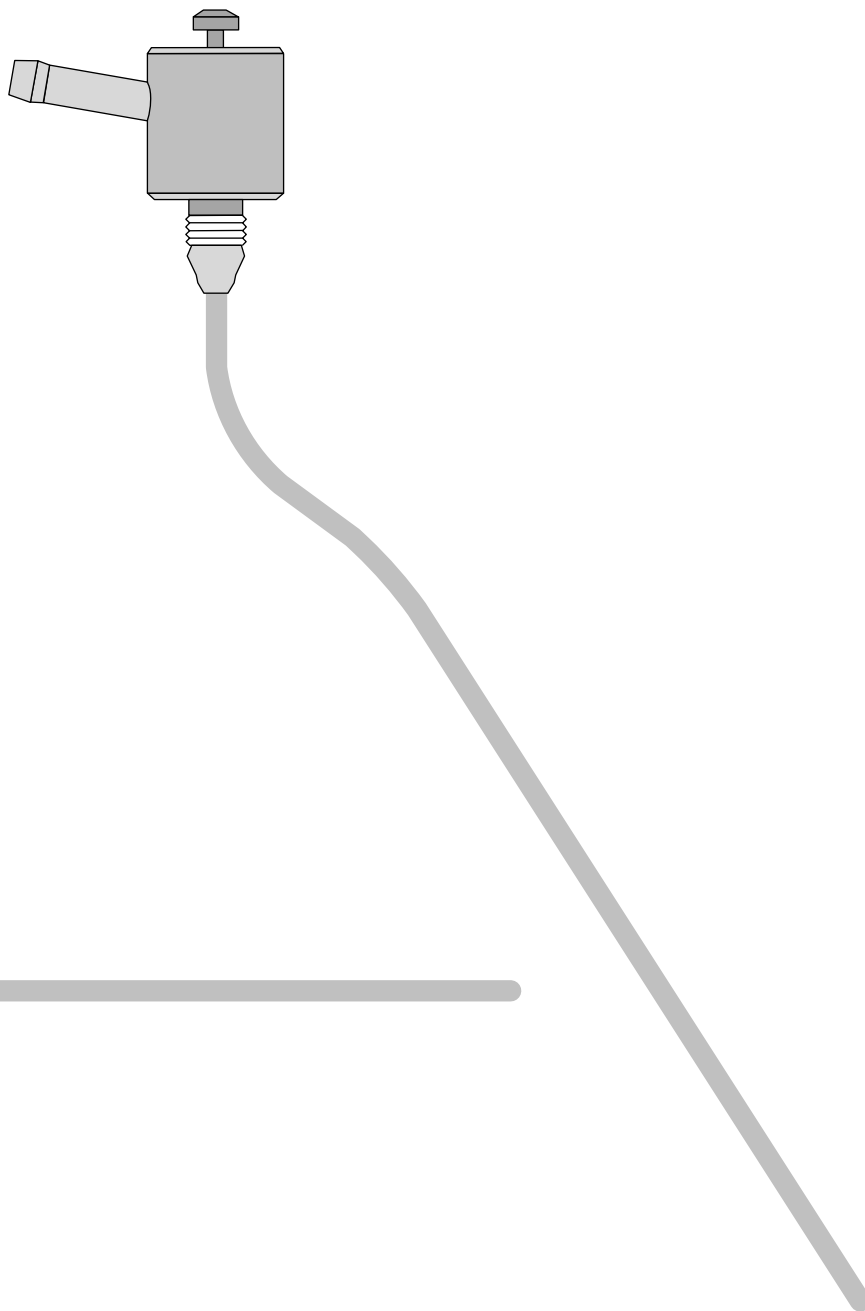

Top view

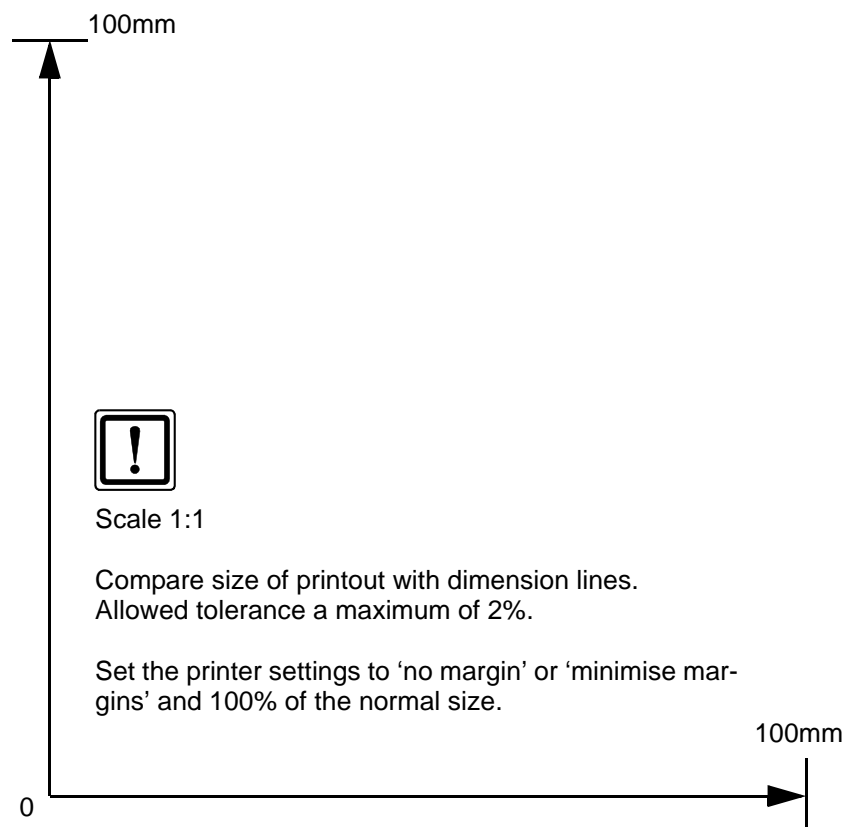

Scale 1:1

Compare size of printout with dimension lines.  
Allowed tolerance a maximum of 2%.

Set the printer settings to 'no margin' or 'minimise margins' and 100% of the normal size.