



Water Heater

Thermo Top Evo Parking Heater



With FuelFix

Installation Documentation Skoda Rapid

Validity

Manufacturer	Model	Type	EG BE No. / ABE
Skoda	Rapid	NH1	e11 * 2007 / 46 * 0250 * ...

Motorisation	Fuel	Transmission type	Output in kW	Displacement in cm ³	Engine code
1.4 TDI	Diesel	DSG	66	1422	CUSB
1.2 TSI	Petrol	6-speed SG	81	1197	CJZD

DSG = dual clutch transmission

SG = manual transmission

From model year 2016

Left-hand drive vehicle

Verified equipment variants: Automatic air-conditioning
Halogen main headlights
Halogen daytime running lights
Halogen front fog lights
Start / Stop
Euro 6
Rough Road Package

Not verified: Manual air-conditioning
Passenger compartment monitoring
Headlight washer system

Total installation time: approx. 9.5 hours

Skoda Rapid

Table of Contents

Validity	1	Preparing Installation Location	13
Necessary Components	2	Preparing Heater	15
Installation Overview	2	Installing Heater	17
Information on Total Installation Time	2	Exhaust Part 1	19
Information on Operating and Installation Instructions	3	1.4 TDI Coolant Circuit	20
Information on Validity	4	1.2 TSI Coolant Circuit	27
Technical Information	4	Combustion Air	32
Explanatory Notes on Document	4	Fuel	33
Preliminary Work	5	Installing FuelFix for 1.4 TDI	36
Heater Installation Location	5	Installing FuelFix for 1.2 TSI	39
Preparing Electrical System	6	Exhaust Part 2	43
Electrical System	8	Final Work	47
Fan Controller	9	FuelFix Template for 1.4 TDI	48
MultiControl CAR Option	11	FuelFix Template for 1.2 TSI	49
Remote Option (Telestart)	11	Operating Instructions	50
ThermoCall Option	12		

Necessary Components

- Basic delivery scope of Thermo Top Evo in accordance with price list
- Installation kit with FuelFix for Skoda Rapid 2016 Petrol and diesel: **1325010B**
- Also required: Additional kit automatic A/C AAC for Skoda Rapid 2016 **1325048_**
- Also required in case of 1.2 TSI: Additional kit Skoda Rapid 1.2 TSI **1325137_**
- Heater control in accordance with price list and upon consultation with end customer
- In case of MultiControl CAR installation: Timer cable extension: **1319724_**
- In case of Telestart, indicator lamp in accordance with price list and in consultation with end customer

Installation instructions:

- Arrange for the vehicle to be delivered with the tank only about $\frac{1}{4}$ full.
- The installation location of the push button in case of Telestart or ThermoCall should be confirmed with the end customer.
- Depending on the space required and the vehicle manufacturer's instructions, we recommend the use of a vehicle battery with a higher electrical capacity.

Installation Overview

Legend:

1. Heater
2. Engine compartment fuse holder
3. Passenger compartment relay and fuse holder
4. PWM GW
5. Circulating pump
6. MultiControl CAR
7. Metering pump
8. FuelFix

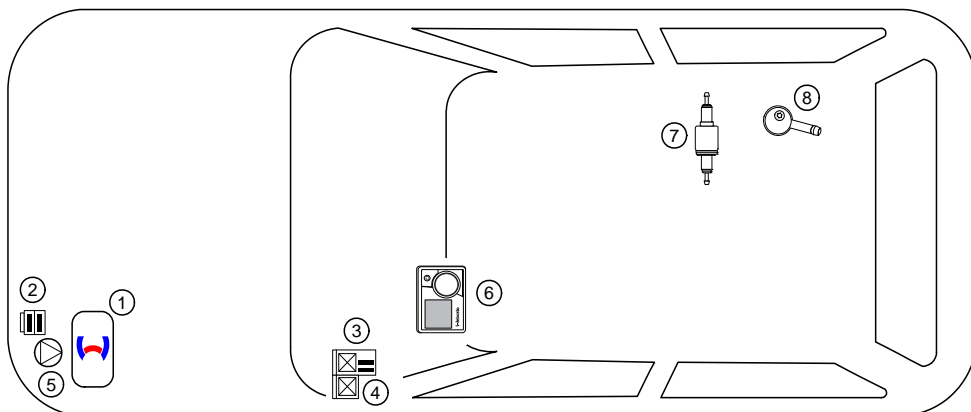

Information on Total Installation Time

The total installation time includes the time needed for mounting and demounting the vehicle-specific components, the heater specific installation time and all other times required for the system integration and initial start-up of the heater. The total installation time may vary for vehicle equipment other than provided.

Information on Operating and Installation Instructions

1 Important information (not complete)

1.1 Installation and repair



The improper installation or repair of Webasto heating and cooling systems can cause fire or the leakage of deadly carbon monoxide, leading to serious injury or death.



To install and repair Webasto heating and cooling systems you need to have completed a special company training course and have the appropriate technical documentation, special tools and special equipment.



Installation and repair may ONLY be carried out by persons trained and certified in a Webasto training course. NEVER try to install or repair Webasto heating or cooling systems if you have not completed a Webasto training course, you do not have the necessary technical skills and you do not have the technical documentation, tools and equipment available to ensure that you can complete the installation and repair work properly.

Only use genuine Webasto parts. See the Webasto air and water heaters accessories catalogue for this purpose.

1.2 Operation

To ensure safe operation, we recommend having the heater checked every two years by an authorised Webasto dealer, especially when used over a long period and/or under extreme environmental conditions.

Do not operate the heater in closed rooms due to the danger of poisoning and suffocation.

Always switch off the heater before refuelling.

The heater may only be used with the prescribed fuel diesel (DIN EN 590) or petrol (DIN EN 228).

The heater may not be cleaned with a high-pressure cleaner.

1.3 Please note

ALWAYS follow all Webasto installation and operating instructions and observe all warnings.

To become familiar with and understand all functions and properties of the heater, the operating instructions must be read carefully and observed at all times.

For proper, safe installation and repair work, the installation instructions with all warnings and safety information must be carefully read and observed at all times. Please always contact a workshop authorised by Webasto for all installation and repair work.

Important

Webasto shall assume no liability for defects, damage and injuries resulting from a failure to observe the installation, repair and operating instructions of the information contained in them.

This liability exclusion particularly applies to improper installations and repairs, installations and repairs by untrained persons or in the case of a failure to use genuine spare parts.

The liability due to culpable disregard to life, limb or health and due to damage or injuries caused by a wilful or reckless breach of duty remain unaffected, as does the obligatory product liability.

Installation should be carried out according to the general, standard rules of technology. Unless specified otherwise, fasten hoses, lines and wiring harnesses to original vehicle lines and wiring harnesses using cable ties. Insulate loose wire ends and tie back. Connectors on electronic components have to audibly click into place during installation.

Sharp edges should be fitted with rub protection. Spray unfinished body areas, e.g. drilled holes, with anti-corrosion wax (Tectyl 100K).

Observe the instructions and guidelines of the respective vehicle manufacturer for demounting and mounting vehicle specific components!

The initial startup is to be executed with the Webasto Thermo Test Diagnosis.

When installing a programmable control module (e.g. a PWM Gateway), the corresponding settings must be checked or adjusted.

2 Statutory regulations governing installation

Guidelines	Thermo Top Evo
Heating Directive ECE R122	E1 00 0258
EMC Directive ECE R10	E1 04 5627

Note

The regulations of these guidelines are binding in the scope of the Directive 70/156/EEC and/or 2007/46/EC (for new vehicle models from 29/04/2009) and should also be observed in countries in which there are no special regulations.

Important

Failure to follow the installation instructions will result in the invalidation of the type approval for the heater and therefore invalidation of the general **homologation of the vehicle**.

Note

The heater is licensed in accordance with paragraph 19, section 3, No. 2b of the StVZO (German Road Traffic Licensing Authority).

2.1 Excerpt from ECE regulation 122 (heating system) paragraph 5 for the installation of the heater

Beginning of excerpt.

ANNEX VII

REQUIREMENTS FOR COMBUSTION HEATERS AND THEIR INSTALLATION

1. GENERAL REQUIREMENTS

1.7.1. A clearly visible tell-tale in the operator's field of view shall inform when the combustion heater is switched on or off.

2. VEHICLE INSTALLATION REQUIREMENTS

2.1. Scope

2.1.1. Subject to paragraph 2.1.2, combustion heaters shall be installed according to the requirements of this Annex.

2.1.2. Vehicles of category O having liquid fuel heaters are deemed to comply with the requirements of this Annex.

2.2. Positioning of heater

2.2.1. Body sections and any other components in the vicinity of the heater must be protected from excessive heat and the possibility of fuel or oil contamination.

2.2.2. The combustion heater shall not constitute a risk of fire, even in the case of overheating. This requirement shall be deemed to be fulfilled if the installation ensures an adequate distance to all parts and suitable ventilation, by the use of fire resistant materials or by the use of heat shields.

2.2.3. In the case of M2 and M3 vehicles, the heater must not be positioned in the passenger compartment. However, an installation in an effectively sealed envelope which also complies with the conditions in paragraph 2.2.2 may be used.

2.2.4. The label referred to in paragraph 1.4 or a duplicate, must be positioned so that it can be easily read when the heater is installed in the vehicle.

2.2.5. Every reasonable precaution should be taken in positioning the heater to minimise the risk of injury and damage to personal property.

2.3. Fuel supply

2.3.1. The fuel filler must not be situated in the passenger compartment and must be provided with an effective cap to prevent fuel spillage.

2.3.2. In the case of liquid fuel heaters, where a supply separate to that of the vehicle is provided, the type of fuel and its filler point must be clearly labelled.

2.3.3. A notice, indicating that the heater must be shut down before refuelling, must be affixed to the fuelling point. In addition a suitable instruction must be included in the manufacturer's operating manual.

2.4. Exhaust system

2.4.1. The exhaust outlet must be located so as to prevent emissions from entering the vehicle through ventilators, heated air inlets or opening windows.

2.5. Combustion air inlet

2.5.1. The air for the combustion chamber of the heater must not be drawn from the passenger compartment of the vehicle.

2.5.2. The air inlet must be so positioned or guarded that blocking by rubbish or luggage is unlikely.

2.6. Heating air inlet

2.6.1. The heating air supply may be fresh or recirculated air and must be drawn from a clean area not likely to be contaminated by exhaust fumes emitted either by the propulsion engine, the combustion heater or any other vehicle source.

2.6.2. The inlet duct must be protected by mesh or other suitable means.

2.7. Heating air outlet

2.7.1. Any ducting used to route the hot air through the vehicle must be so positioned or protected that no injury or damage could be caused if it were to be touched.

2.7.2. The air outlet must be so positioned or guarded that blocking by rubbish or luggage is unlikely.

End of excerpt.

In multilingual versions the German language is binding.

Skoda Rapid

Information on Validity

This installation documentation applies to Skoda Rapid Petrol and diesel vehicles - for validity see page 1 - from model year 2016 and later, assuming technical modifications to the vehicle do not affect installation, any liability claims excluded. Depending on the vehicle version and equipment, modifications may be necessary during installation with respect to this 'installation documentation'.

Vehicle and engine types, equipment variants and other specifications not listed in this installation documentation have not been tested. However, installation according to this installation documentation may be possible.

Technical Information

Special Tools

- Hose clamp pliers for auto-tightening hose clamps
- Hose clamp pliers for Clic hose clamps of type W
- Automatic wire stripper, 0.2 - 6mm²
- Crimping pliers for cable lug / tab connector, 0.5 - 6mm²
- Torque wrench for 2.0 - 10 Nm
- Hose clamping pliers
- Metric thread-setter kit
- Deep-hole marker
- Webasto Thermo Test Diagnosis with current software

Dimensions

- All dimensions are in mm.

Tightening torque values

- Tightening torque values of 5x13 heater bolts and 5x11 heater stud bolts = 8Nm.
- Tightening torque value of 5x15 water connection piece retaining plate bolt = 7Nm.
- Tighten other bolt connections in accordance with manufacturer's instructions or in accordance with state-of-the-art technology.

Explanatory Notes on Document

You will find an identification mark on the outside top right corner of the page in question to provide you with a quick overview of the individual working steps.

Special features are highlighted using the following symbols:

Mechanical System



Electrical System



Coolant Circuit



Combustion Air



Fuel



Exhaust Gas



Software



Specific risk of damage to components.



Specific risk due to electrical voltage.



Specific risk of injury or fatal accidents.



Specific risk of fire or explosion.



Reference to the manufacturer's vehicle-specific documents or to the general installation instructions of Webasto components.



Reference to a special technical feature.



The arrow in the vehicle icon indicates the position on the vehicle and the viewing angle.



Tightening torque according to the manufacturer's vehicle-specific documents.



Preliminary Work

Vehicle



- Open the fuel tank cap.
- Ventilate the fuel tank.
- Close the fuel tank cap again.
- Depressurise the cooling system.
- Disconnect and completely remove the battery together with the carrier.
- Remove the windscreen wipers.
- Remove the coolant reservoir cap.
- Remove the coolant reservoir partition wall.
- Remove the windscreen wiper motor.
- Remove the air filter and the intake hose (only in case of 1.2 TSI).
- Remove the left front wheel.
- Remove the left front wheel-well inner panel.
- Remove the horns (there can be one or two) with the bracket.
- Remove the lateral instrument panel trim on the left and right.
- Remove the A/C control panel.
- Remove the passenger compartment fuse box.
- Remove the underride protection.
- Remove the right vehicle underbody trim.
- Fold up the seating surface of the rear bench seat.
- Open the tank-fitting service lid.

Heater

- Remove years that do not apply from the type and duplicate label.
- Attach the duplicate label (type label) visibly in the appropriate place in the engine compartment.



Heater Installation Location

- 1 Heater

Installation location

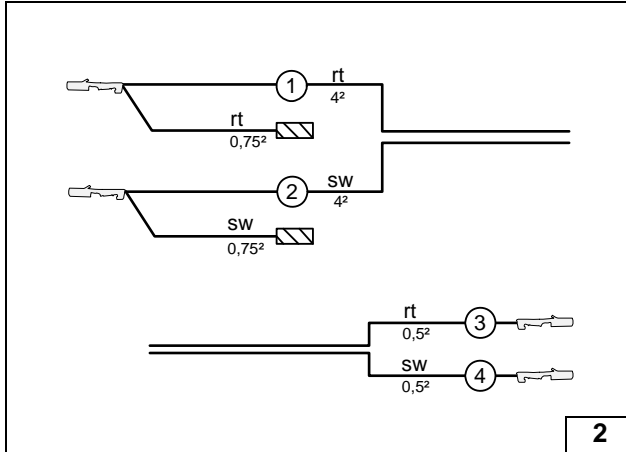
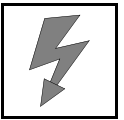

Preparing Electrical System

Wire sections retain their numbering in the entire document.

- ① Red (rt) wire of fan wiring harness
- ② Black (sw) wire of fan wiring harness
- ③ Red (rt) wire of PWM control wiring harness
- ④ Black (sw) wire of PWM control wiring harness

Assigning wires

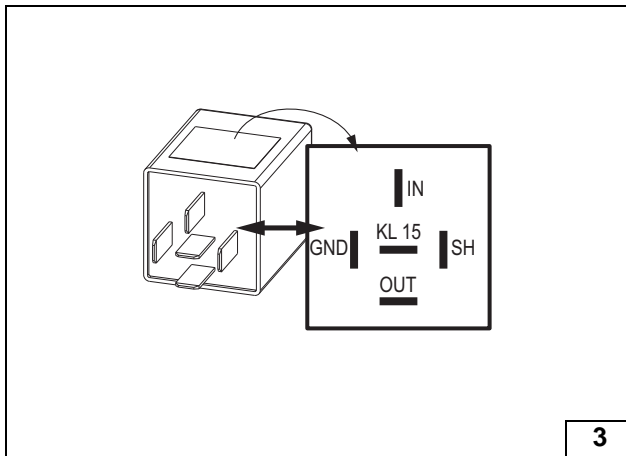

Check the PWM-Gateway settings when starting up the heater and adjust if necessary.

Settings:

- Duty cycle: 100% (DC)
- Frequency: not relevant
- Voltage: 3.6V
- Function: High side



View of PWM-GW

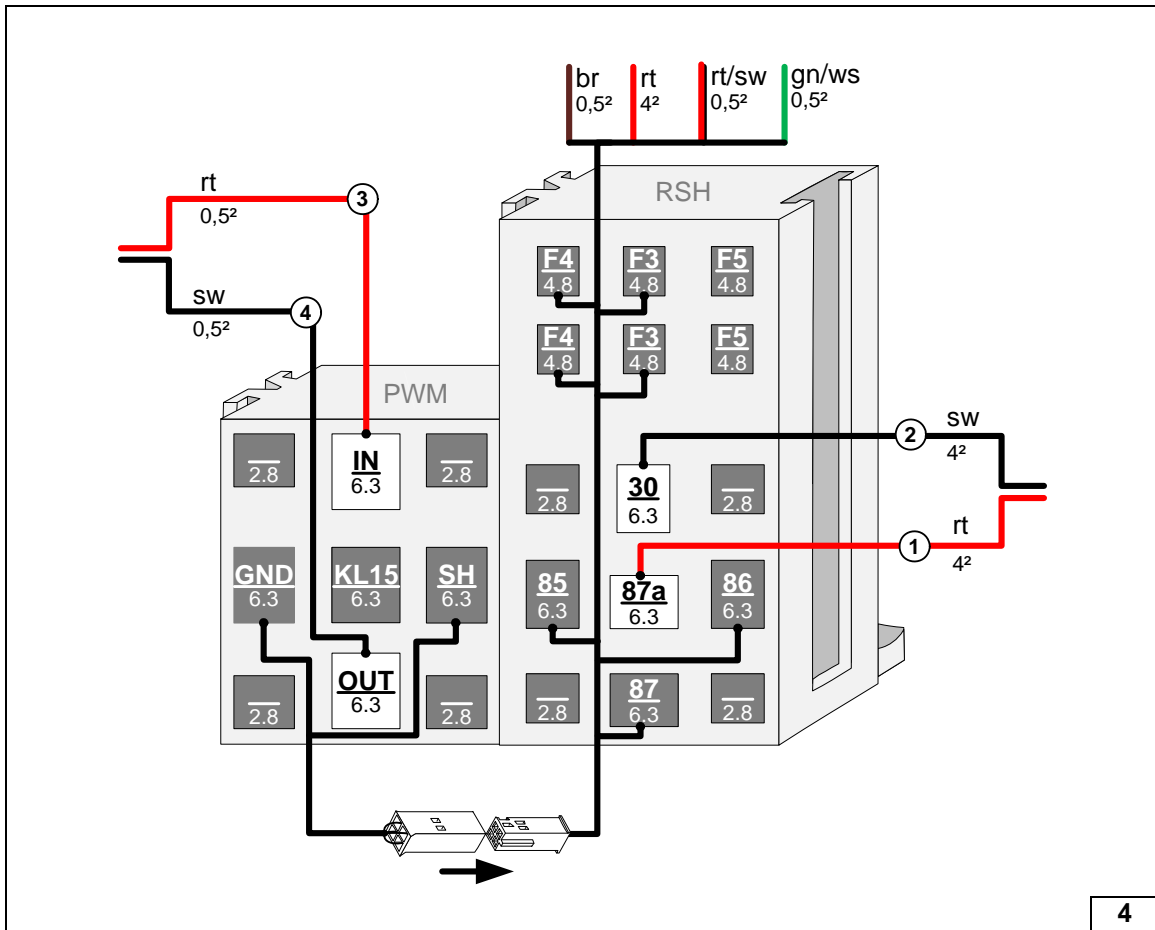

Interlocking PWM GW and passenger compartment relay and fuse holder sockets, inserting connector into bushing, connecting wires

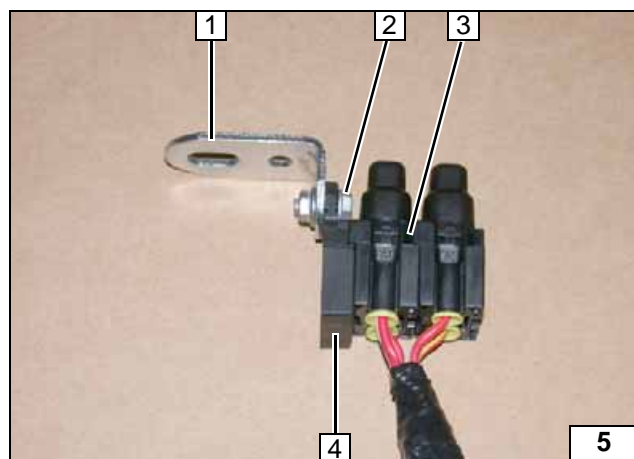

- 1 Angle bracket
- 2 M5x16 bolt, large diameter washer [2x], nut
- 3 Fuses F1-2
- 4 Fuse holder retaining plate

**Preparing
fuse holder of
engine com-
partment**

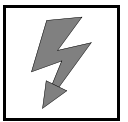

Electrical System



Engine compartment fuse holder

- 1 Angle bracket
- 2 M6x20 bolt, large diameter washer, original vehicle hole, flanged nut

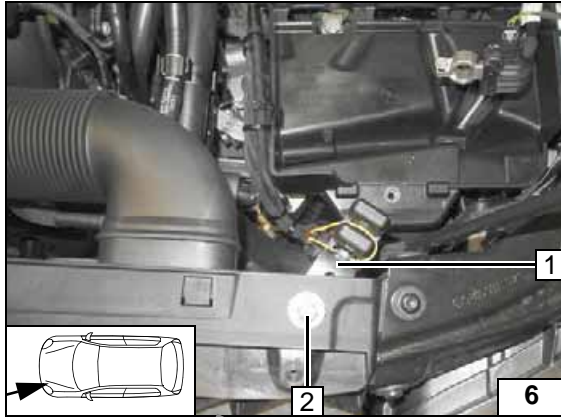

Passenger compartment wiring harness pass through

- 1 Protective rubber plug pass through coolant reservoir
- 2 Wiring harnesses of heater, heater control

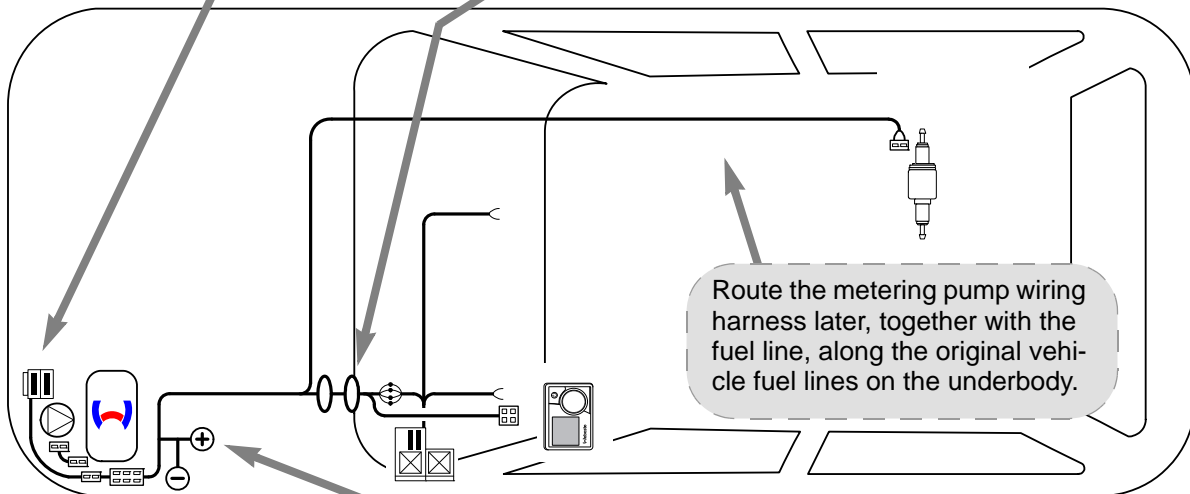
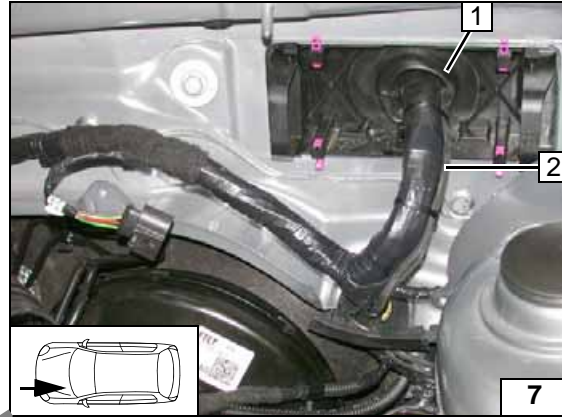

Wiring harness routing diagram



Earth wire

- 1 Earth wire on original vehicle earth support point

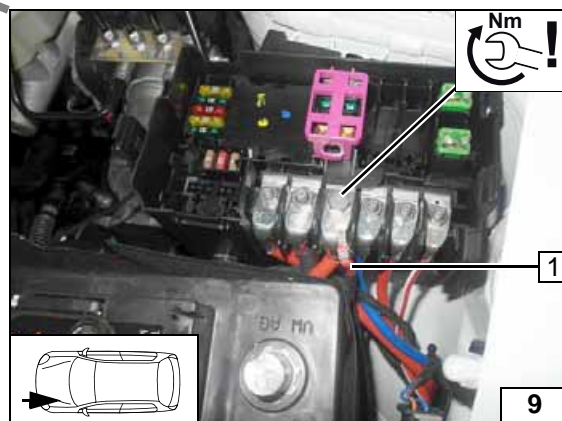

Positive wire

- 1 Positive wire on positive distributor





Fan Controller



System wiring diagram

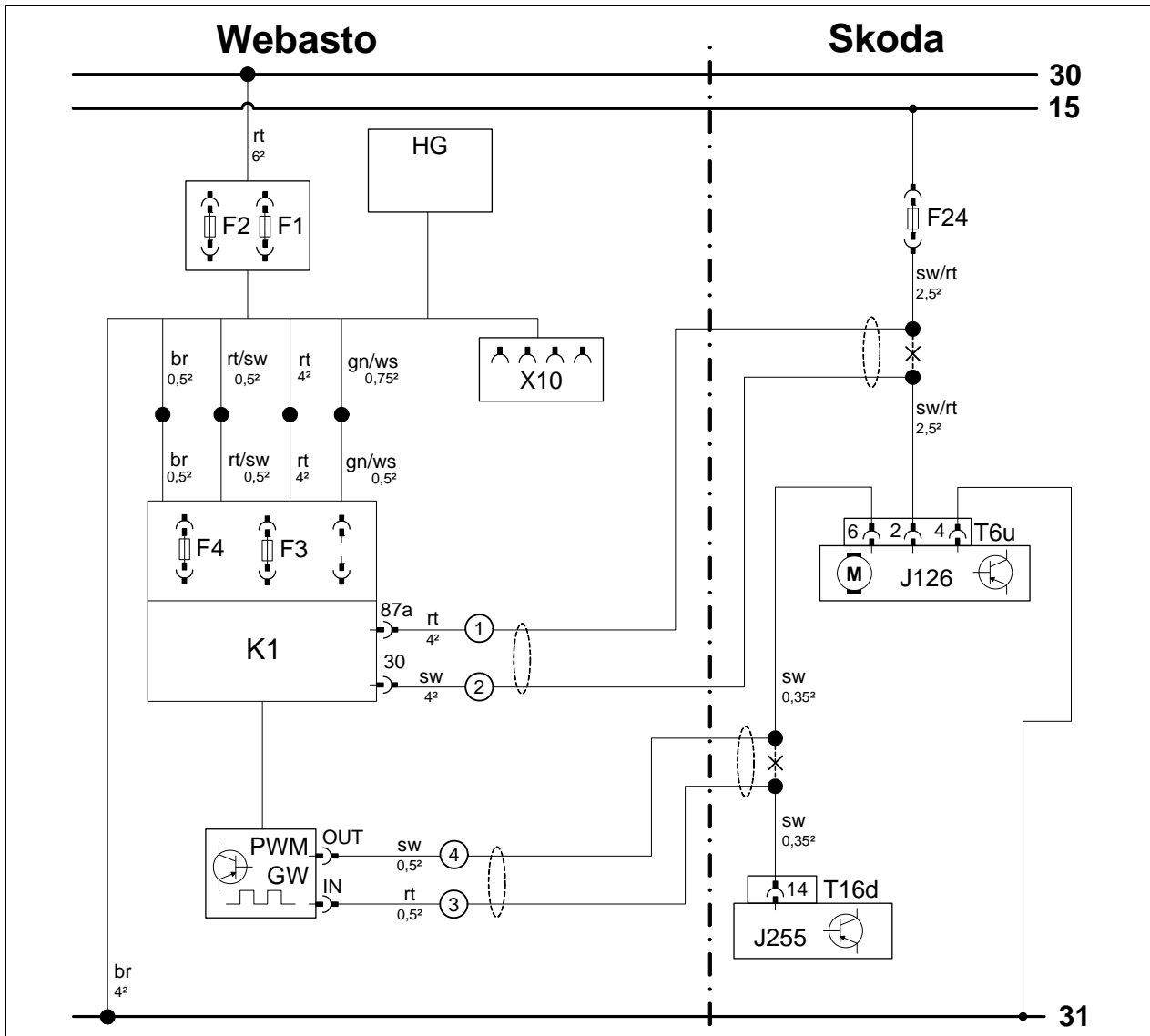

Webasto components		Vehicle components		Colours and symbols	
HG	TT-Evo heater	F24	30A fuse	rt	red
F1	20A fuse	J126	Fan unit	ws	white
F2	30A fuse	T6u	6-pin connector J126	sw	black
X10	4-pin connector of heater control	J255	A/C control unit	br	brown
F3	1A fuse	T16d	16-pin connector J255	gn	green
F4	25A fuse				
K1	Fan relay				
PWM GW	Pulse width modulator				
Settings of PWM-GW:					
Duty cycle: 100% (DC)					
Frequency: not relevant					
Voltage: 3.6V				X	Cutting point
Function: High side				Wiring colours may vary.	

Legend

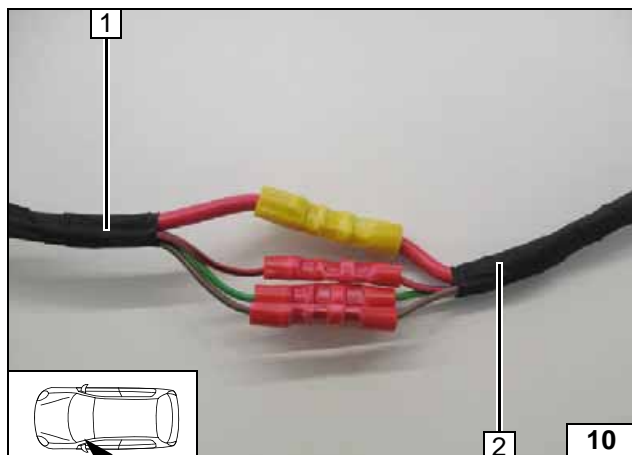

Produce all following electrical connections as shown in the wiring diagram.

- 1 Passenger compartment relay and fuse holder wiring harness
- 2 Heater wiring harness

Connecting same colour wires of wiring harnesses

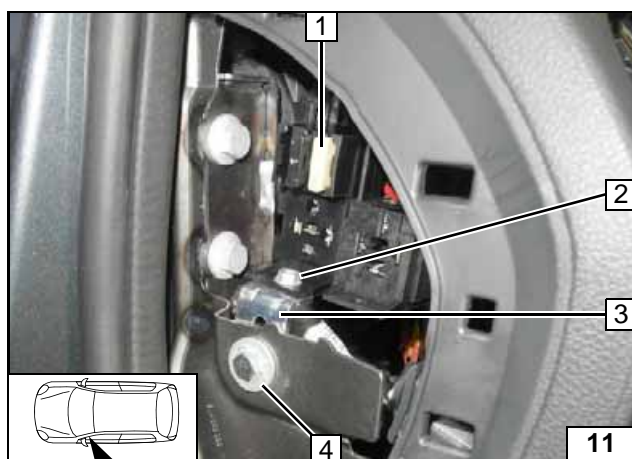

- 1 25A fuse F4
- 2 M5x16 bolt, large diameter washer [2x], nut
- 3 Angle bracket
- 4 M6x20 bolt, large diameter washer, original vehicle hole, flanged nut

Installing passenger compartment relay and fuse holder

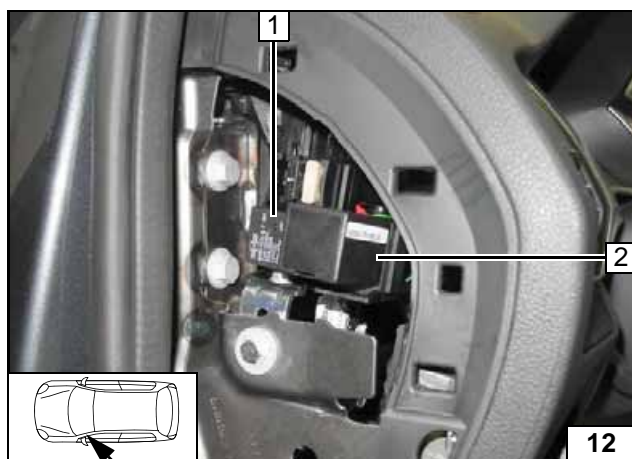

- 1 Relay K1
- 2 PWM GW

Installing relay K1 and PWM GW

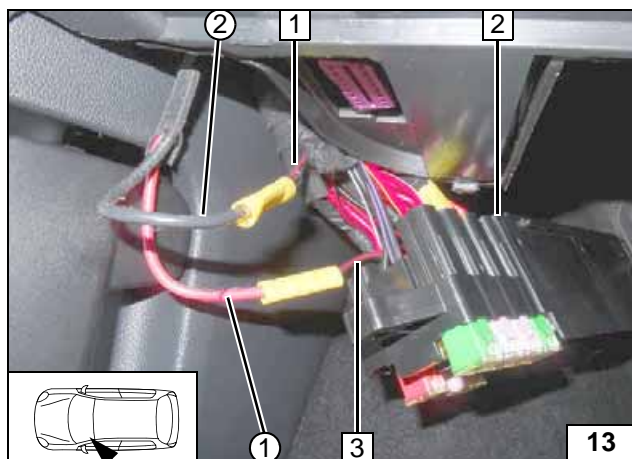

- 1 Black/red (sw/rt) wire of connector GE T6u / pin 2
- 2 Passenger compartment fuse box
- 3 Black/red (sw/rt) wire of fuse F24
- ① Red (rt) wire from K1/87a of fan wiring harness
- ② Black (sw) wire from K1/30 of fan wiring harness

Connecting fan unit

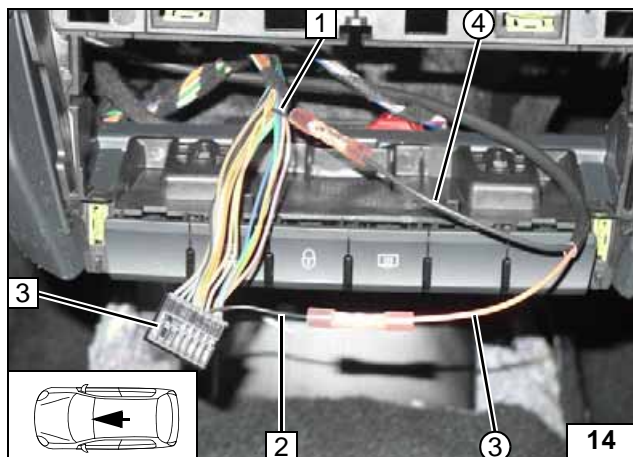

- 1 Black (sw) wire of connector T6u / pin 6
- 2 Black (sw) wire of connector T16d / pin 14
- 3 16-pin connector T16d
- ③ Red (rt) wire from PWM GW/IN of PWM control wiring harness
- ④ Black (sw) wire from PWM GW/OUT of PWM control wiring harness

**Connect-
ing air-con-
ditioning
control
panel**

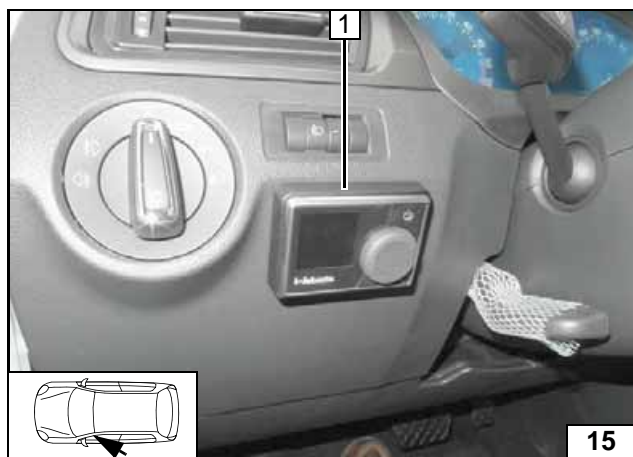

MultiControl CAR Option

- 1 Installation frame



**Installing
MultiControl
CAR**

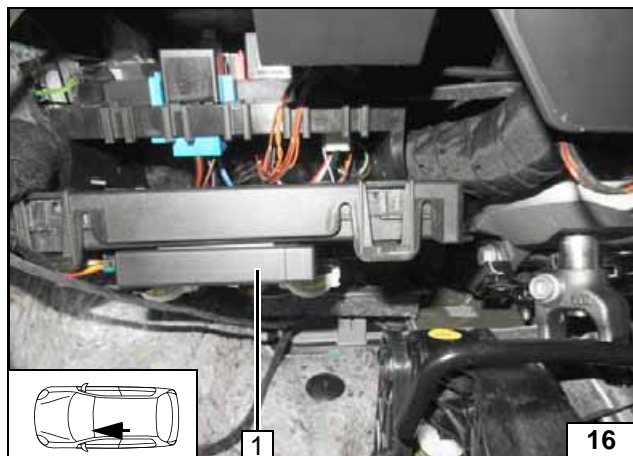

Remote Option (Telestart)

Fasten receiver 1 with double-sided adhesive tape.



**Installing
receiver**

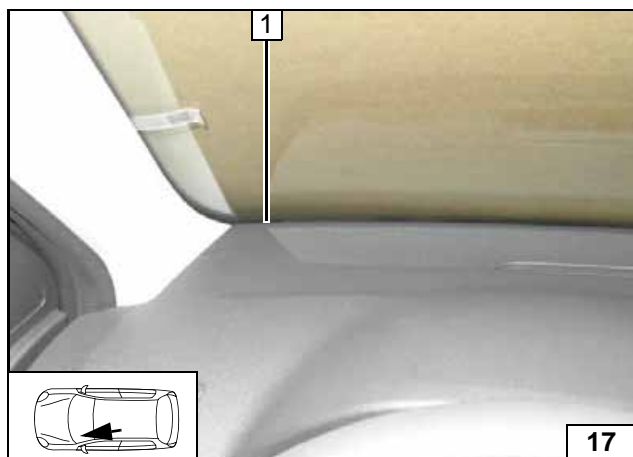

- 1 Aerial

**Installing
aerial**

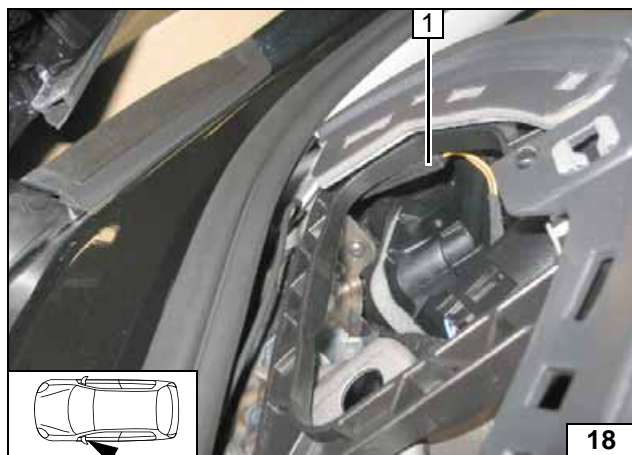
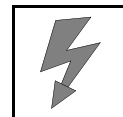

Temperature sensor T100 HTM

Fasten temperature sensor **1** with double-sided adhesive tape.



Installing temperature sensor

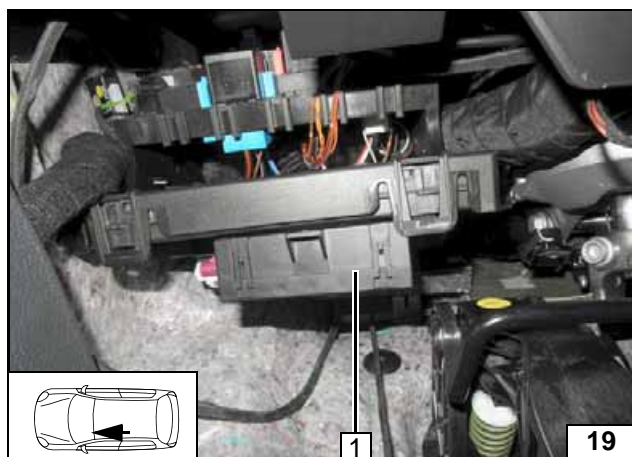

ThermoCall Option

Fasten receiver **1** with double-sided adhesive tape.



Installing receiver

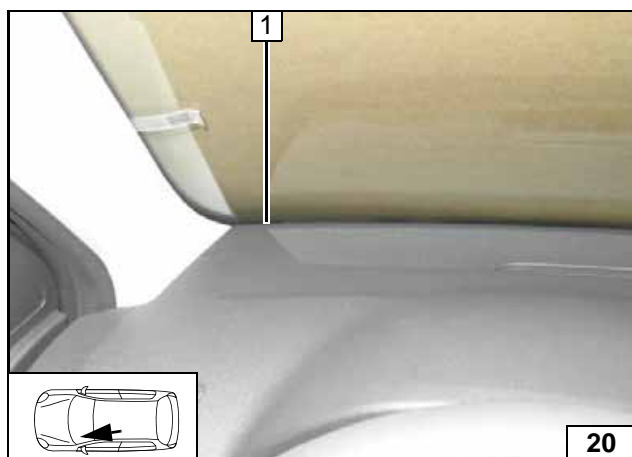

1 Aerial (optional)

Installing aerial

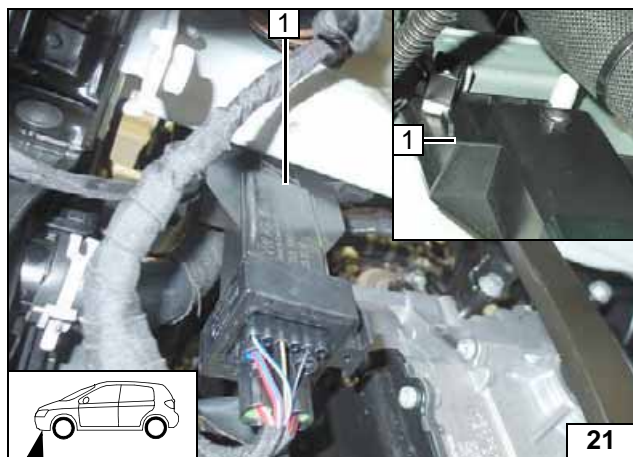
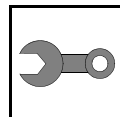

Preparing Installation Location

- 1 Original vehicle relay, turned by 180°, reattached

Reinstalling relay and fuse holder

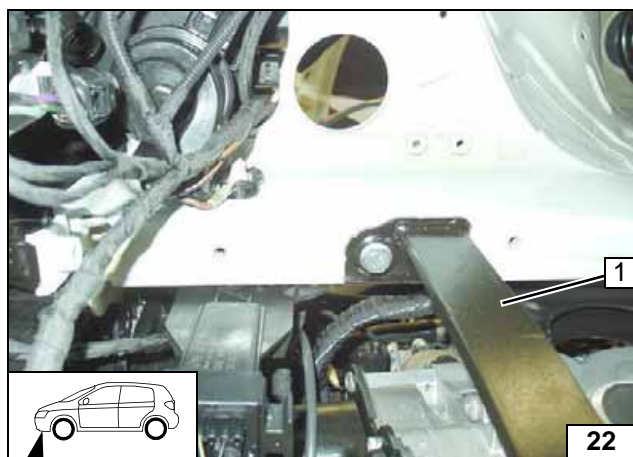

- 1 Underride protection strut

Removing strut (if present)

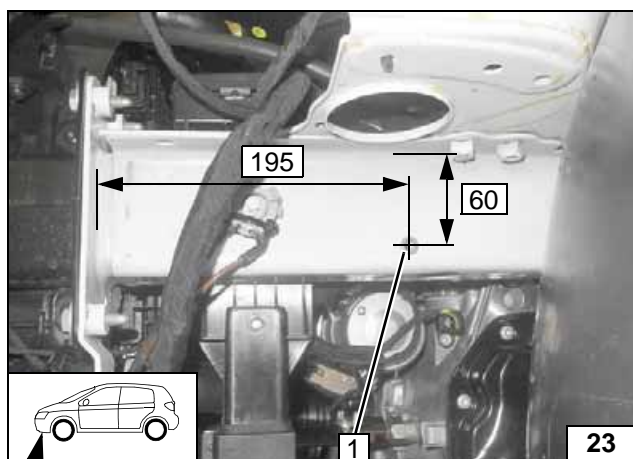

- 1 9.1 mm dia. hole; M6 rivet nut

Installing rivet nut

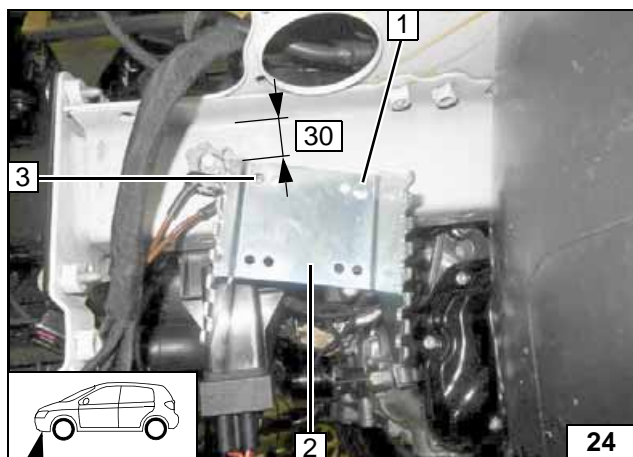

Loosely install bracket 2 and align as shown.

- 1 M6x20 bolt
- 3 Copy hole pattern



Copying hole pattern

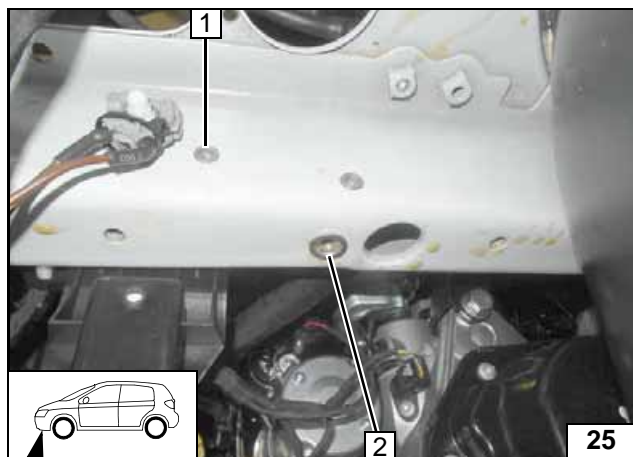
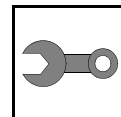

Remove bracket.

- 1 9.1 mm dia. hole; M6 rivet nut
- 2 Existing hole, M8 rivet nut



Installing rivet nuts

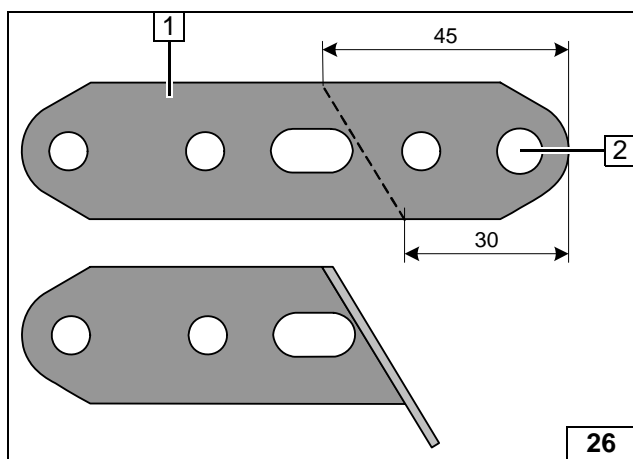

- 1 Angle down perforated bracket A by 90°
- 2 Drill hole to 8.5 mm dia.

Preparing perforated bracket A

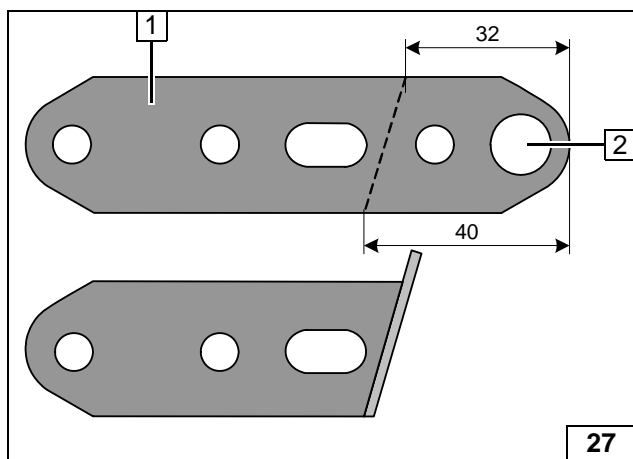

- 1 Angle down perforated bracket B by 90°
- 2 Drill hole to 10.5 mm dia.

Preparing perforated bracket B

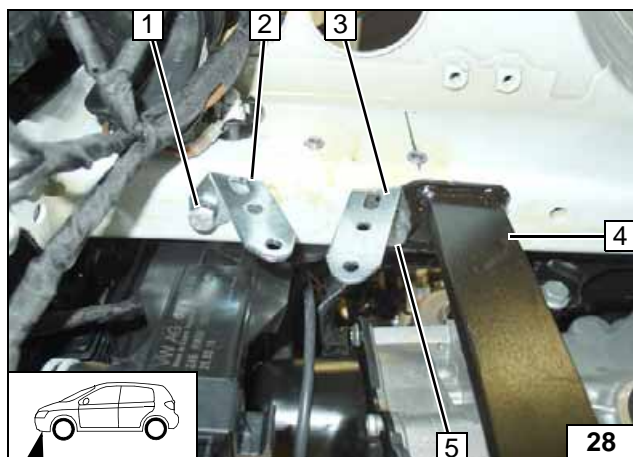

- 1 M8x20 bolt, spring lockwasher, existing threaded hole
- 2 Perforated bracket A
- 3 Perforated bracket B
- 4 Underide protection strut (if present)
- 5 Original vehicle bolt

Installing perforated brackets loosely

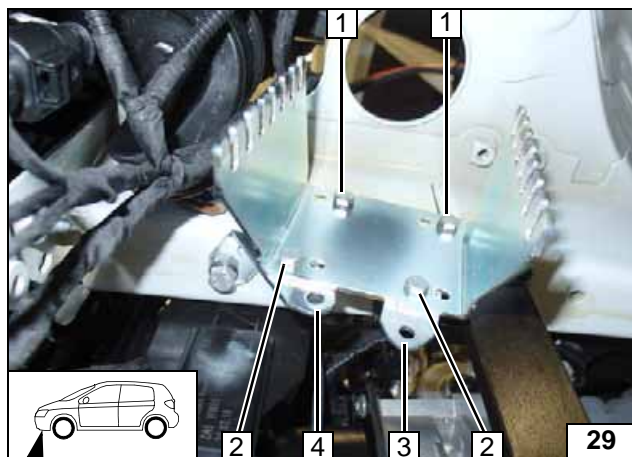

Tighten loose bolt connections.

- 1 M6x20 bolt, spring lockwasher [2x each]
- 2 M6x12 bolt, flanged nut [2x each]
- 3 Perforated bracket B
- 4 Perforated bracket A



Installing bracket

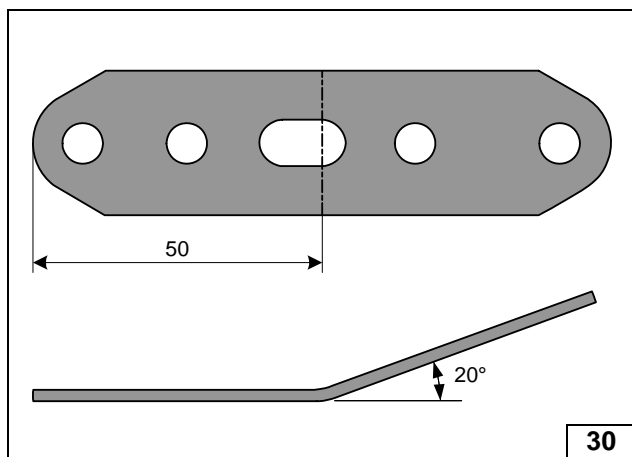

Preparing perforated bracket C

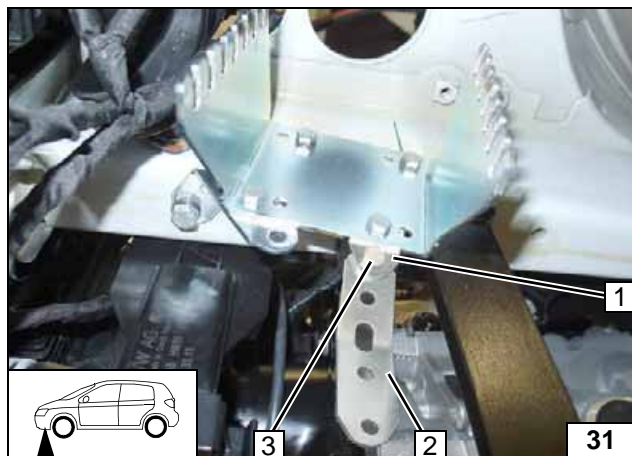

- 1 Perforated bracket B
- 2 Perforated bracket C
- 3 M6x12 bolt, flanged nut

Installing perforated bracket C

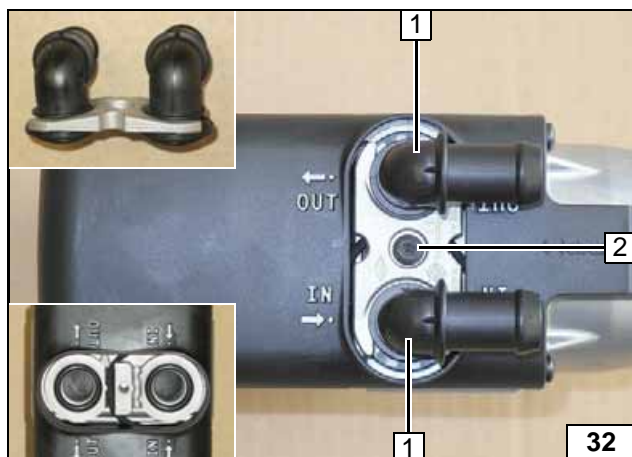

Preparing Heater

- 1 Water connection piece, sealing ring [2x each]
- 2 5x15 self-tapping bolt, retaining plate of water connection piece



Installing water connection piece

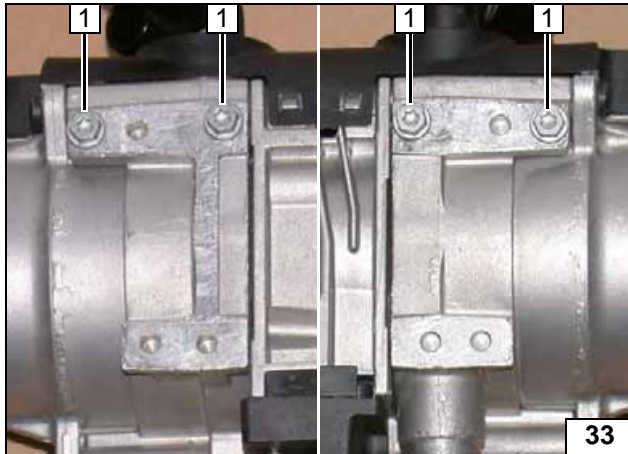
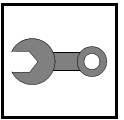

Screw 5x13 self-tapping bolts 1 [4x] into existing holes by a maximum of 3 thread turns.



Premounting bolts loosely

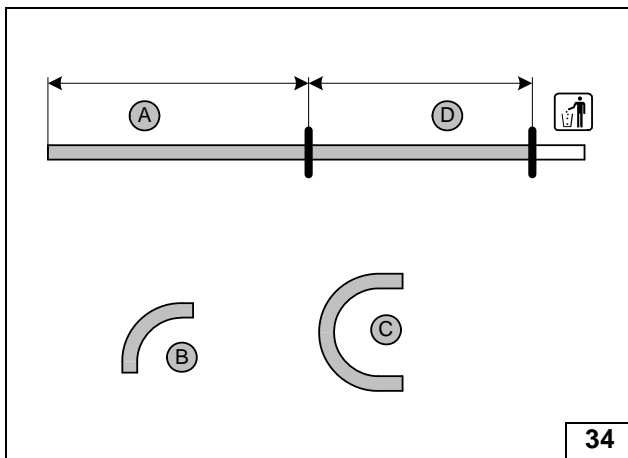

	1.4 TDI	1.2 TSI
A	860	900
B	90°, 18mm dia.	90°, 18mm dia.
C	180°, 18mm dia.	180°, 18mm dia.
D	930	930

Cutting hoses to length

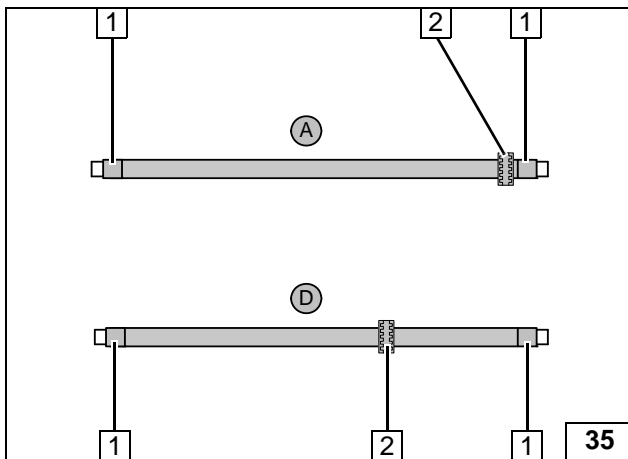

Slide on braided protection hoses and cut to length.



- 1 Cut heat shrink plastic tubing to size, 50 mm long [4x]
- 2 Black (sw) rubber isolator [2x]

Installing braided protection hoses

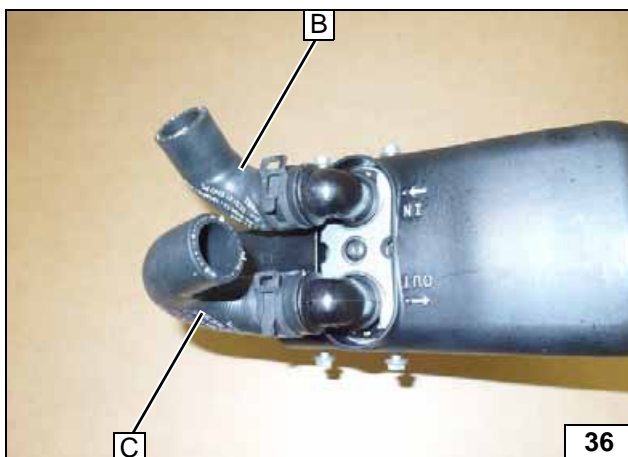

All spring clips = 25 mm dia.



Premounting hoses

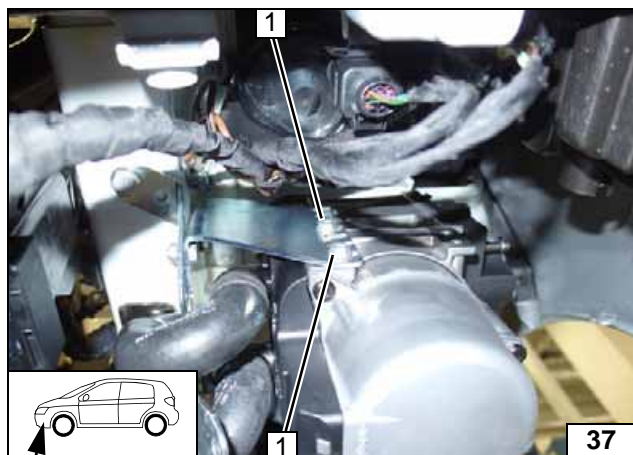
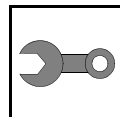

Installing Heater

- 1 Tighten 5x13 self-tapping bolt [2x]

Installing heater

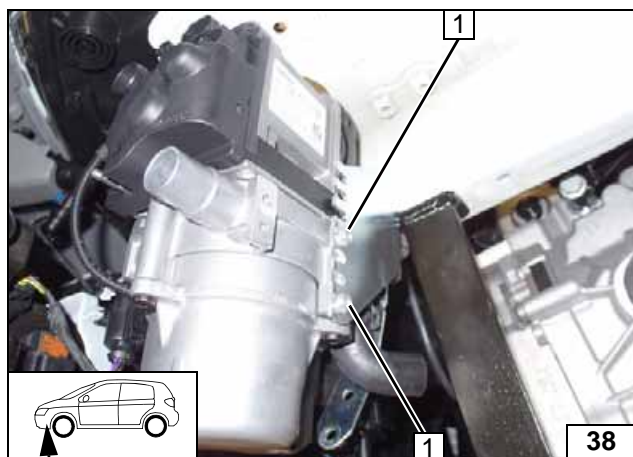

- 1 Tighten 5x13 self-tapping bolt [2x]

Installing heater

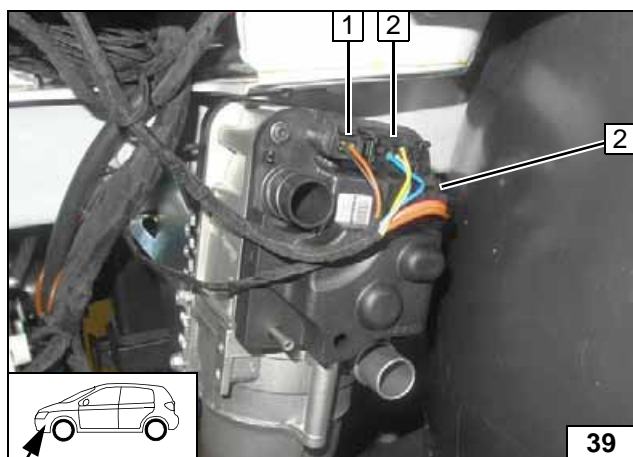

- 1 Connector of circulating pump wiring harness
- 2 Heater wiring harness connector [2x]

Installing wiring harnesses

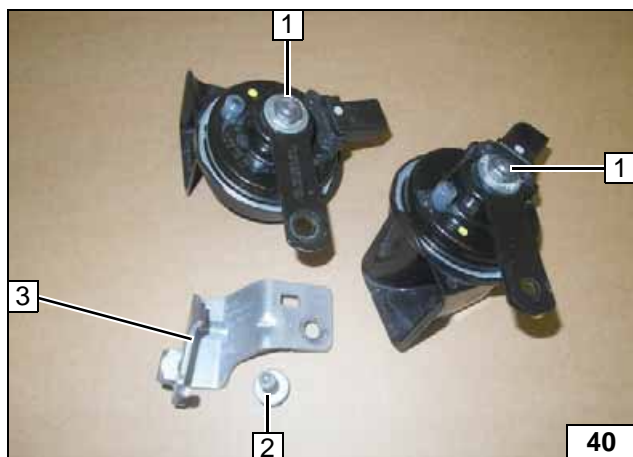

Moving horns

Vehicles with two horns

Detach screw fitting at position 1 [2x]. Discard original vehicle bolt 2 and horn bracket 3.



Disassembling horns (1 to 2 pieces)

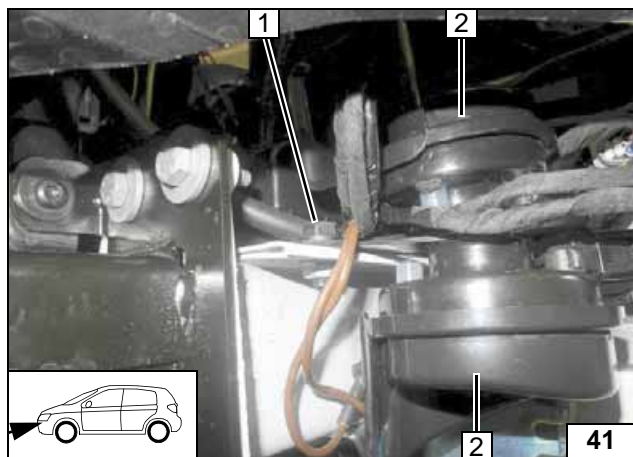
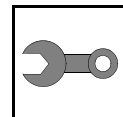

Install horn 2 [2x] with bracket loosely.

- 1 Original vehicle bolt, flanged nut



Installing horns loosely



Align lower horn 2 as shown. Ensure sufficient distance from neighbouring components, correct if necessary.

- 1 Install connector of horn wiring harness [2x]



Aligning lower horn

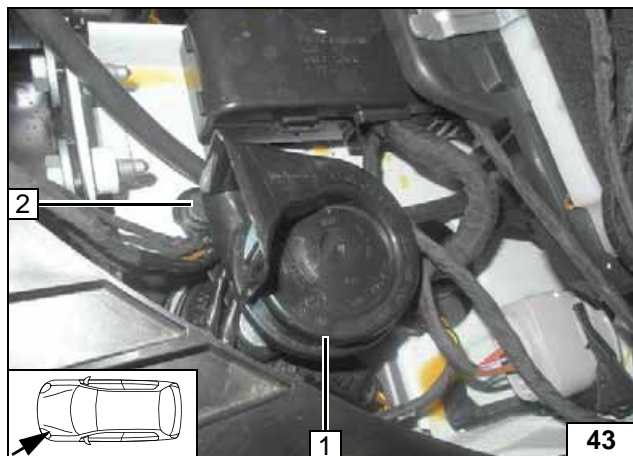

Align upper horn 1 as shown. Ensure sufficient distance from neighbouring components, correct if necessary. Tighten all screw connections.



Aligning upper horn

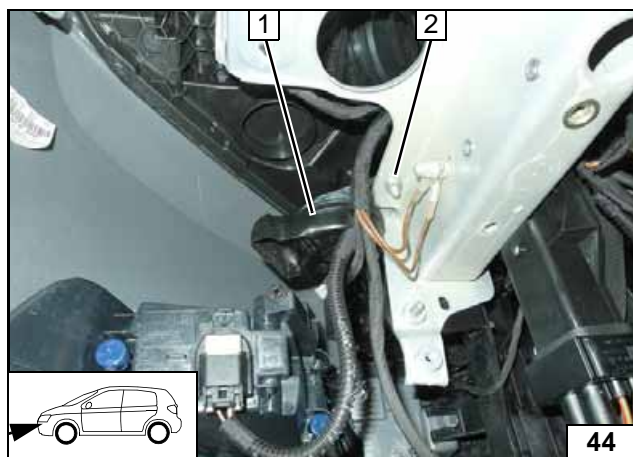

Vehicles with one horn

Install horn 1 with bracket as shown.

- 2 Original vehicle bolt, flanged nut



Installing horn loosely

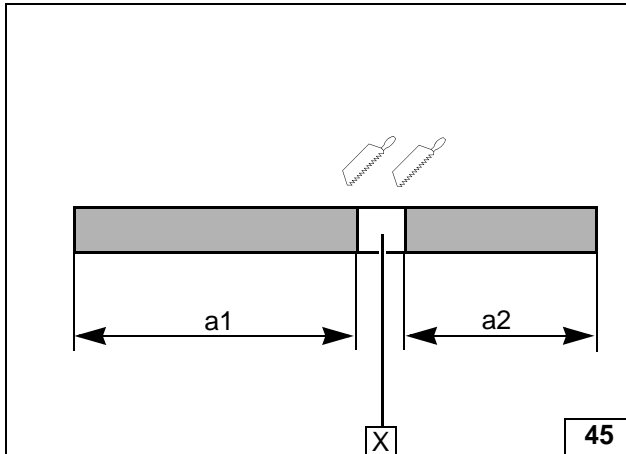
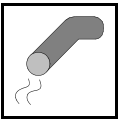

Exhaust Part 1

	1.4 TDi	1.2 TSI
a1	370	280
a2	230	370
X		- - -

Preparing exhaust pipe

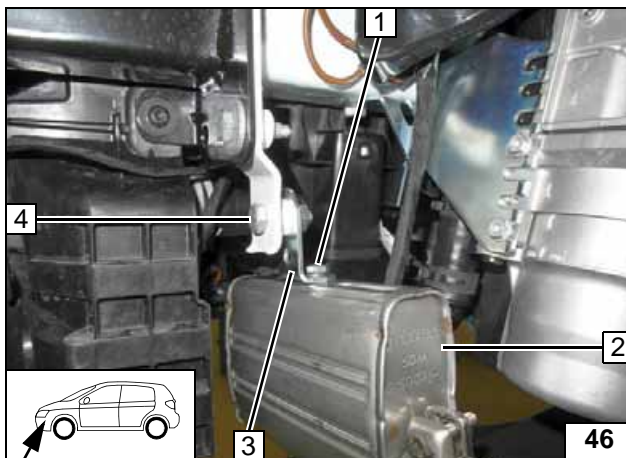

The bumper was removed in the following work steps to improve representation.

- 1 M6x16 bolt, spring lockwasher
- 2 Silencer
- 3 Angle bracket
- 4 8x40 bolt, flanged nut

Installing silencer

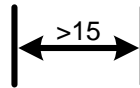
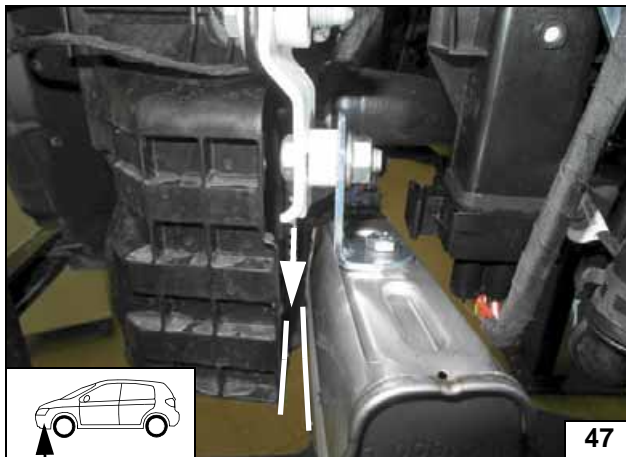

Aligning silencer

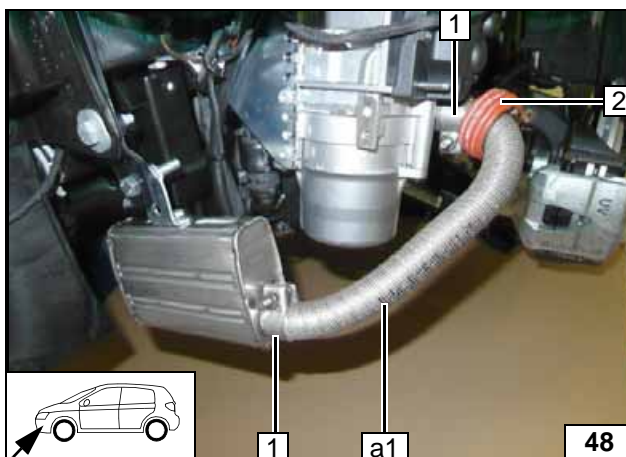

- 1 Hose clamp [2x]
- 2 Spacer bracket

Installing exhaust pipe a1

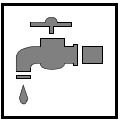

1.4 TDI Coolant Circuit





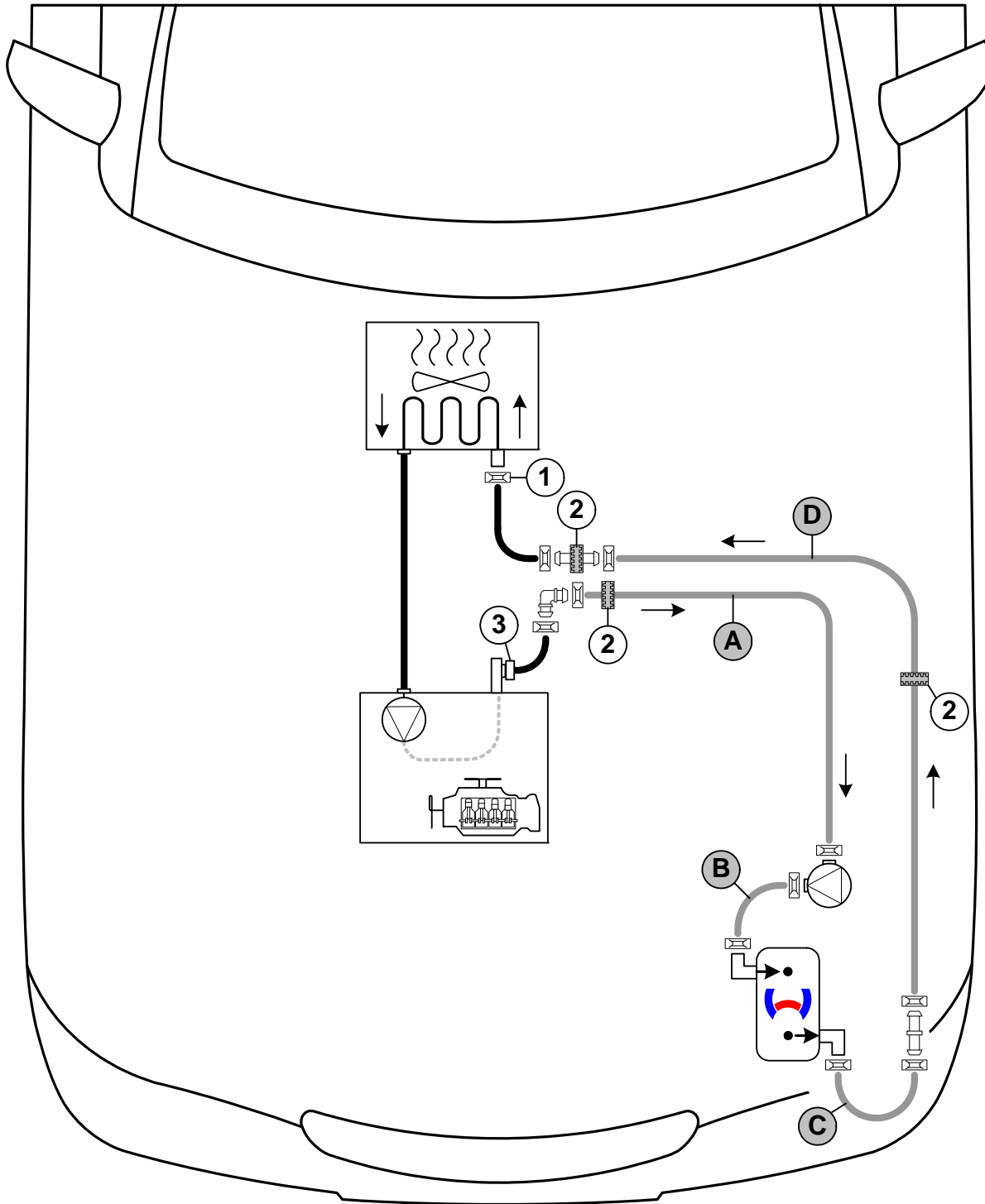

Any coolant running off should be collected in an appropriate container. Route hoses kink-free. Unless specified otherwise, always fasten using cable ties. Position clamps so that other hoses cannot be damaged. The heater must be filled with coolant when installing the hoses.

The connection should be modelled on an 'inline' circuit and based on the following diagram:



Hose routing diagram

All spring clips without a specific designation  = 25 mm dia. All connecting pipes  and  = 18x18mm dia.
1 = Original vehicle spring clip . **2** = Black (sw) rubber isolator .
3 = Coupling piece of engine outlet.



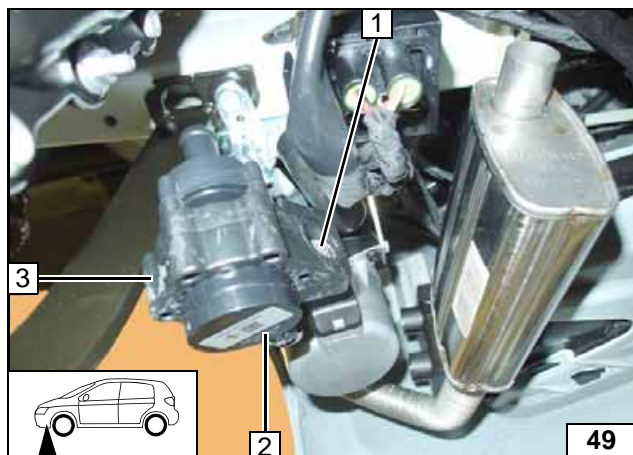

Use lower hole of perforated bracket C.

- 1 M6x25 bolt, flanged nut
- 2 Circulating pump
- 3 Circulating pump mount



Installing circulating pump

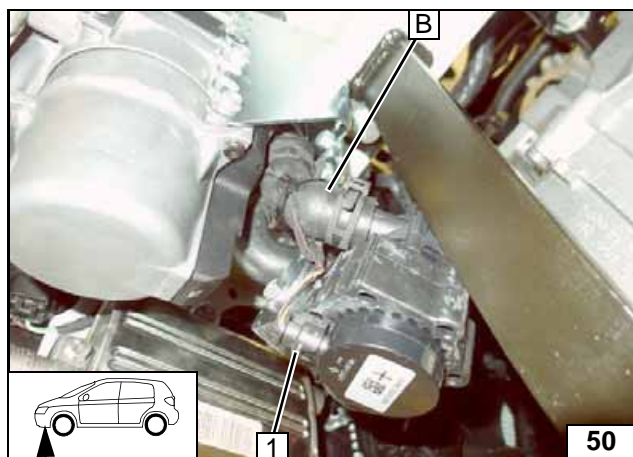

- 1 Connector of circulating pump wiring harness

**Connect-
ing circulat-
ing pump**

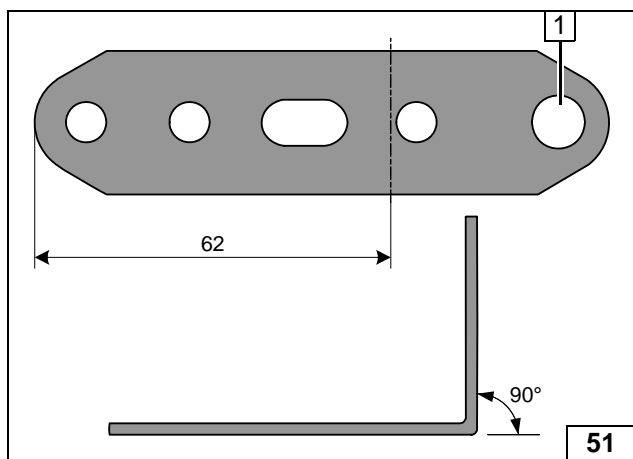

- 1 Drill hole to 8.5 mm dia.

**Preparing
perforated
bracket D**

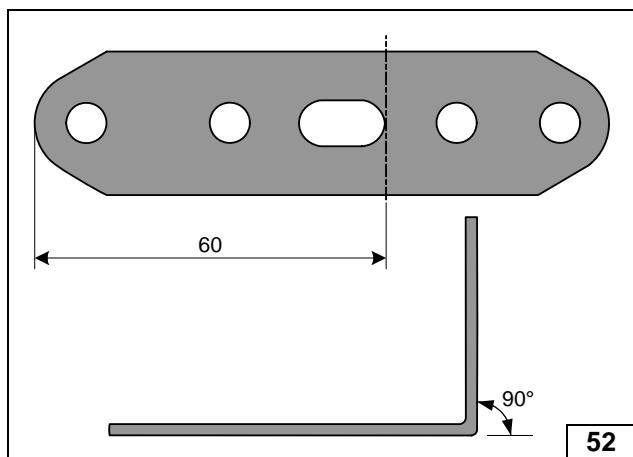

**Preparing
perforated
bracket E**

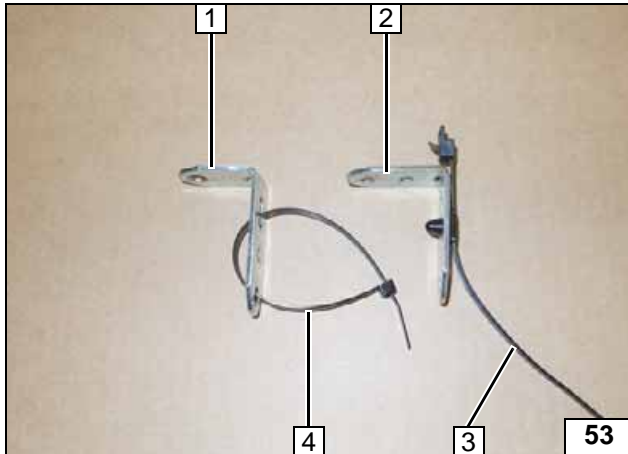

- 1 Perforated bracket D
- 2 Perforated bracket E
- 3 Clip-type cable tie
- 4 Cable tie

Preparing perforated bracket D and E

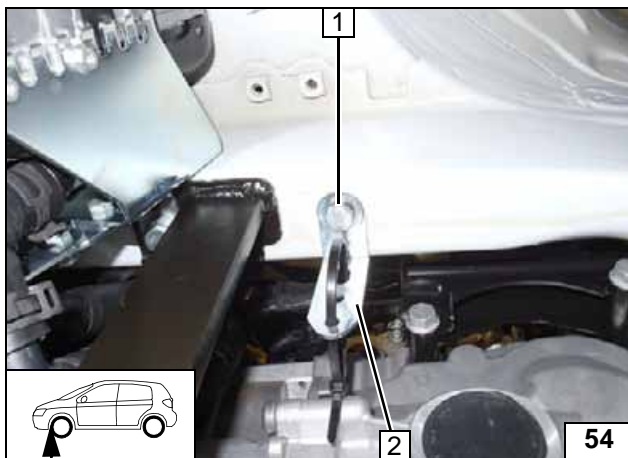

- 1 M8x20 bolt, spring lockwasher, existing threaded hole
- 2 Perforated bracket D

Installing perforated bracket D

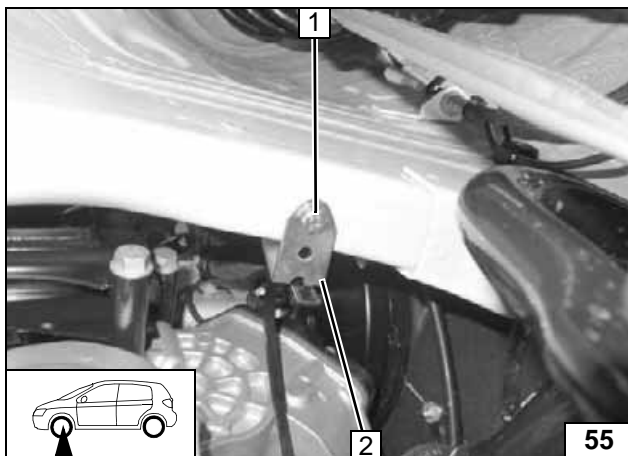

- 1 M6x20 bolt, spring lockwasher, existing threaded hole
- 2 Perforated bracket E

Installing perforated bracket E

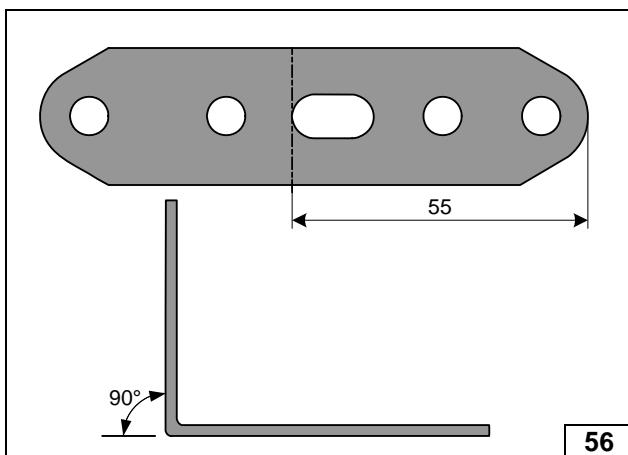

Preparing perforated bracket F

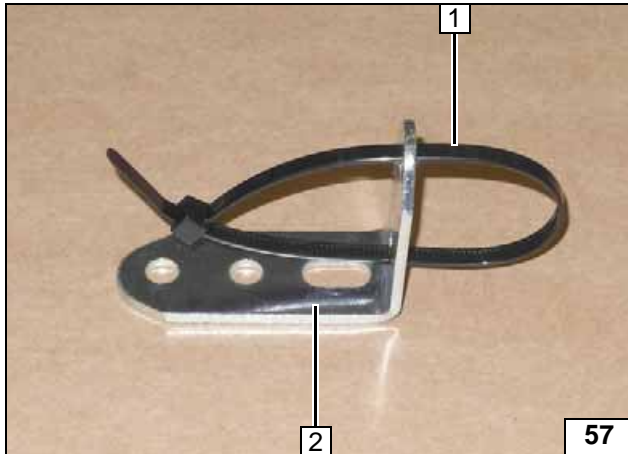

- 1 Cable tie through both holes, don't tighten
- 2 Perforated bracket F

Preparing perforated bracket F

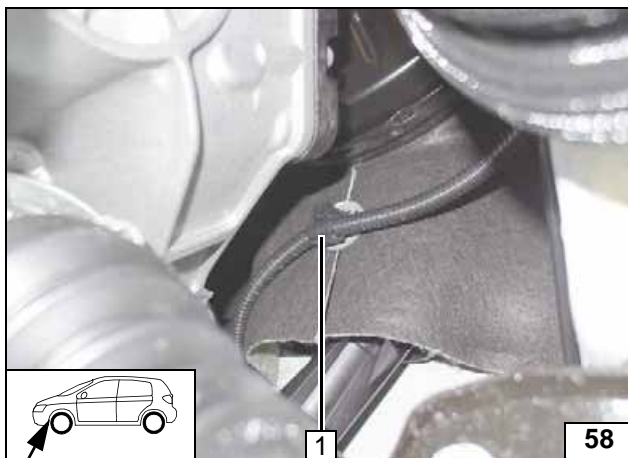

- 1 Discard retaining clamp

Removing retaining clamp

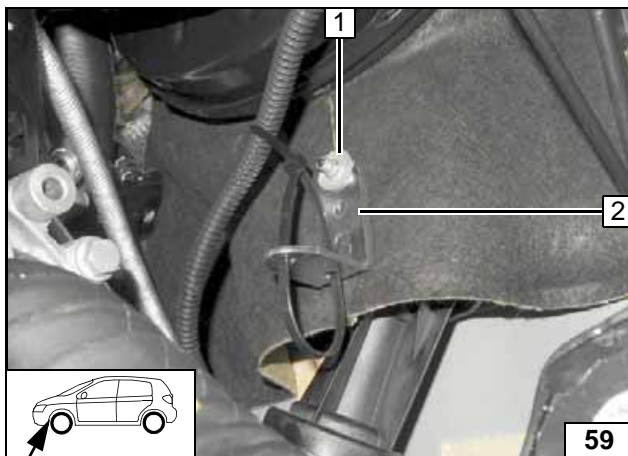

- 1 Plate nut on original vehicle stud bolt
- 2 Perforated bracket F

Installing perforated bracket F

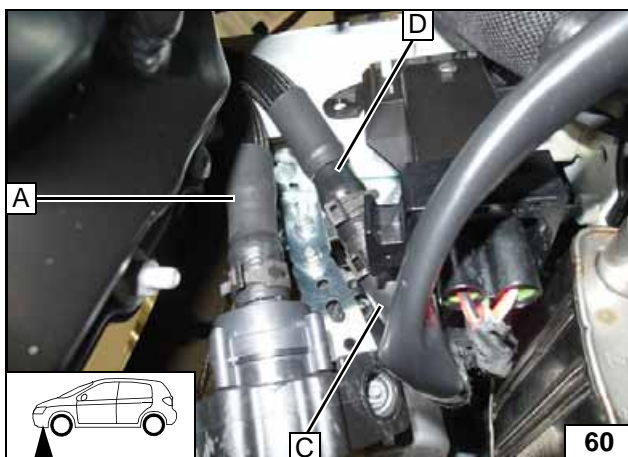

Connecting heater

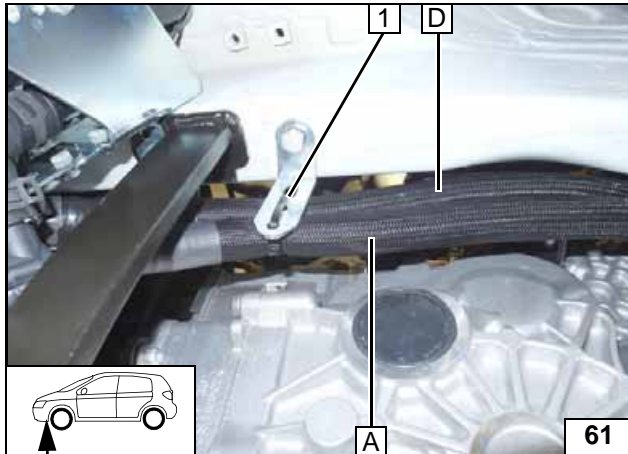

Route hoses **A** and **D** using frame side member cable tie **1** from perforated bracket **D**. Align hoses, tighten cable tie.



Routing in engine compartment

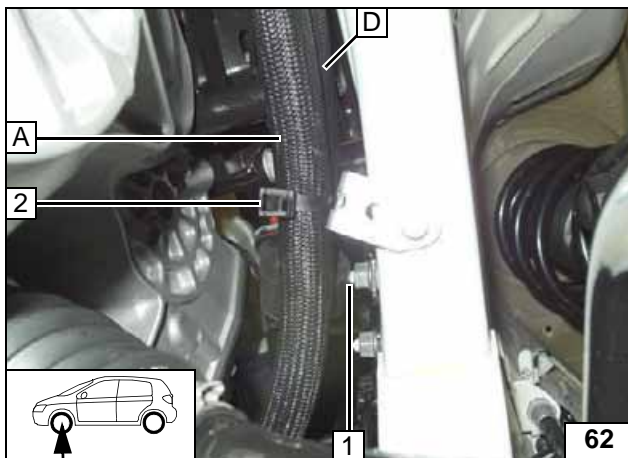

Route hoses **A** and **D** using frame side member clip-type cable tie **2** from perforated bracket **E**. Align hoses, tighten clip-type cable tie.



Routing in engine compartment

1 Position black (sw) rubber isolator

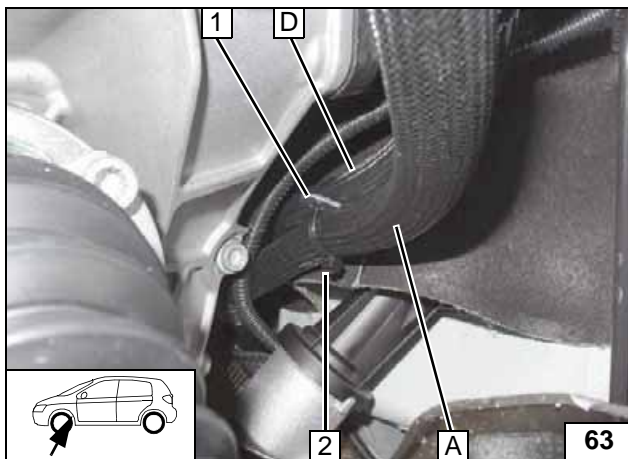

Route hose **D** above and hose **A** under perforated bracket **F** **1** through cable tie **2**. Align hoses, tighten cable tie.



Routing in engine compartment



Remove hose on engine outlet / heat exchanger inlet **1** with coupling piece of engine outlet. Spring clip **2** will be reused.



Cutting point

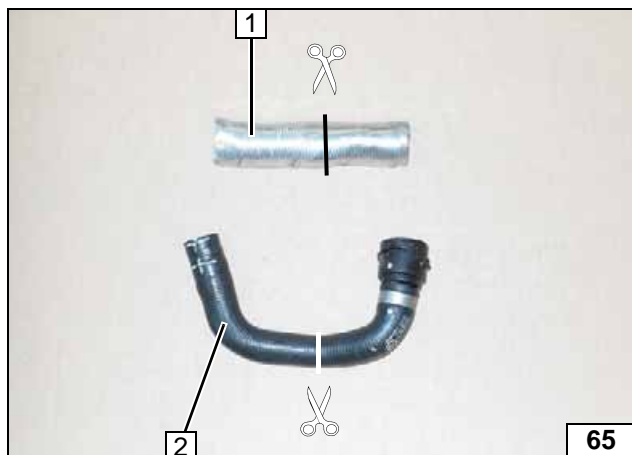

Pull off heat protection hose **1** and cut at the marking.
Cut hose of engine outlet/heat exchanger inlet **2** at the marking.



Cutting point

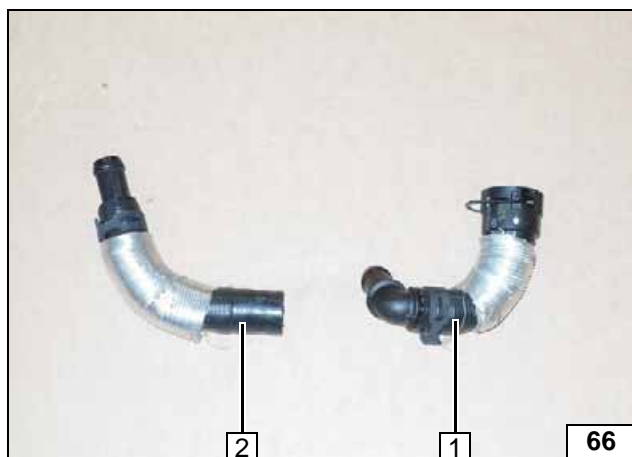

- 1 Engine outlet hose section with heat protection hose
- 2 Heat exchanger inlet hose section with heat protection hose

Cutting point

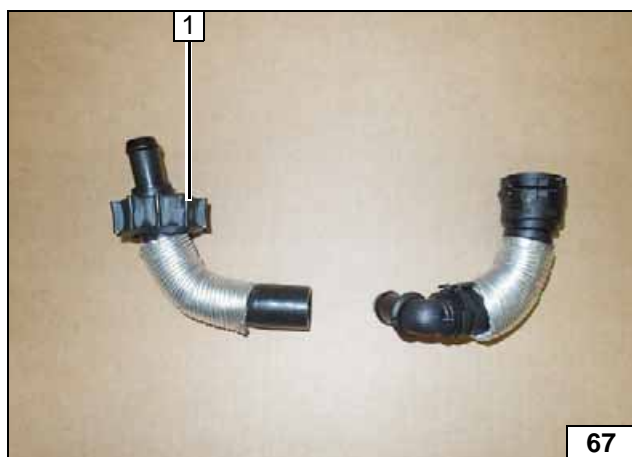

- 1 Position rubber isolator twistedly

Position black (sw) rubber isolator

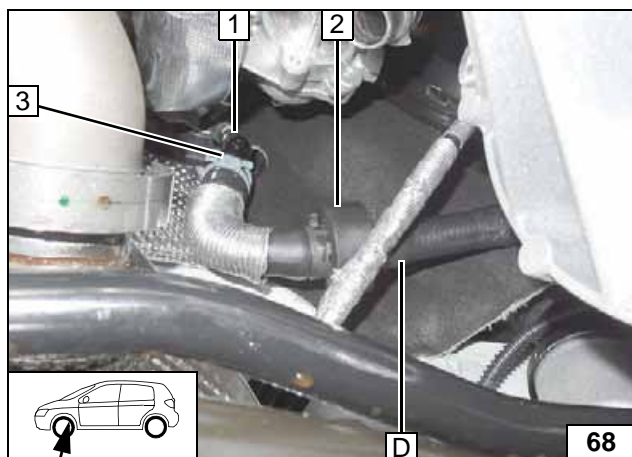

- 1 Connection piece of heat exchanger inlet
- 2 Position black (sw) rubber isolator between spring clips
- 3 Original vehicle spring clip

Connecting heat exchanger inlet

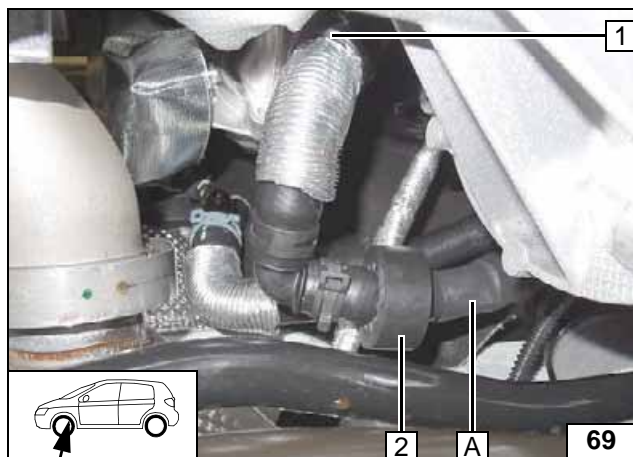

Align hoses.
Ensure sufficient distance from neighbouring components, correct if necessary.

- 1 Coupling piece of engine outlet
- 2 Position black (sw) rubber isolator



**Connect-
ing engine
outlet**

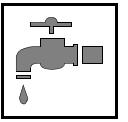

1.2 TSI Coolant Circuit



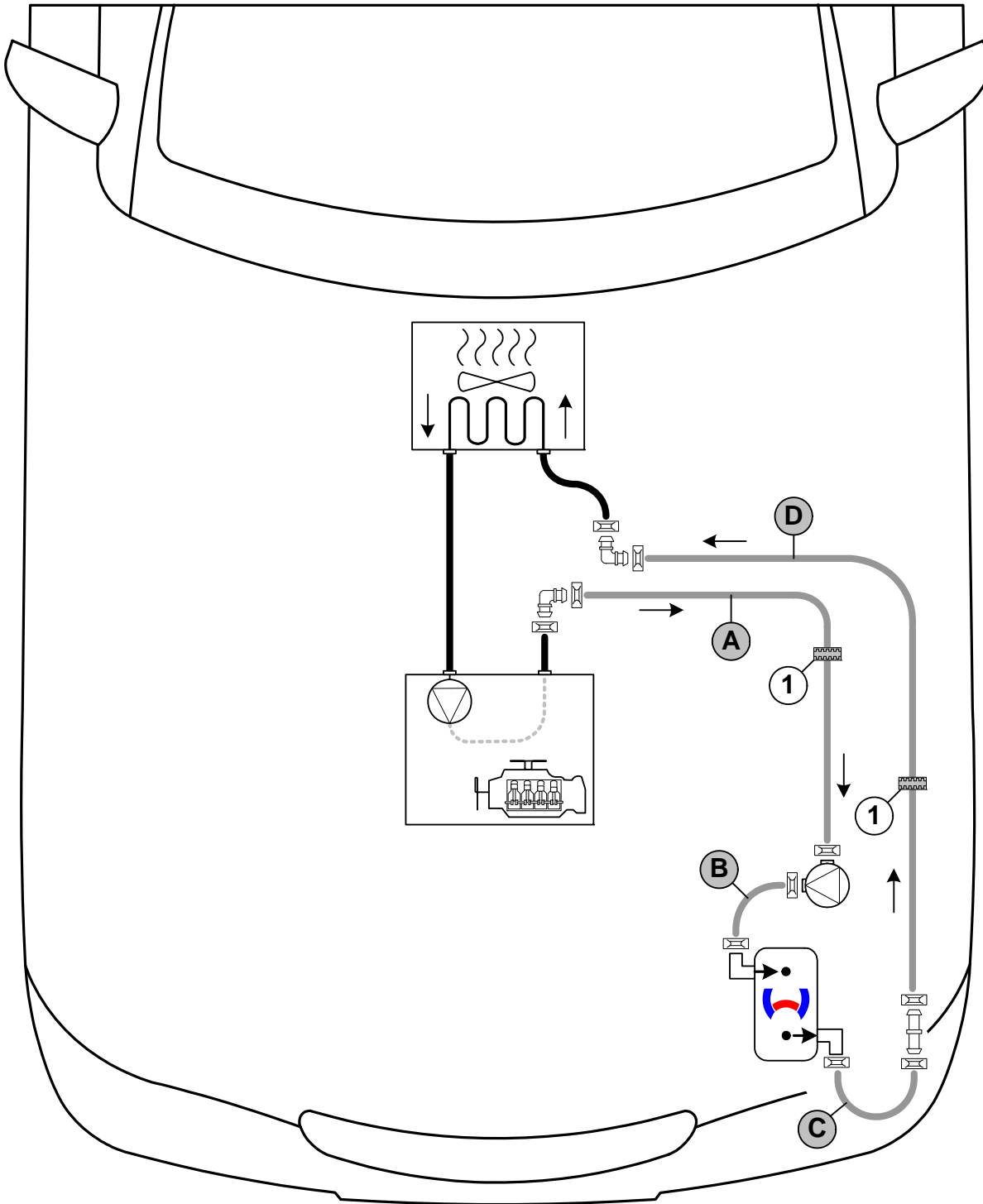

Any coolant running off should be collected in an appropriate container. Route hoses kink-free. Unless specified otherwise, always fasten using cable ties. Position clamps so that other hoses cannot be damaged. The heater must be filled with coolant when installing the hoses.

The connection should be modelled on an 'inline' circuit and based on the following diagram:



Hose routing diagram

All spring clips without a specific designation  = 25 mm dia. All connecting pipes  = 18x18 mm dia.
 1 = Black (sw) rubber isolator .



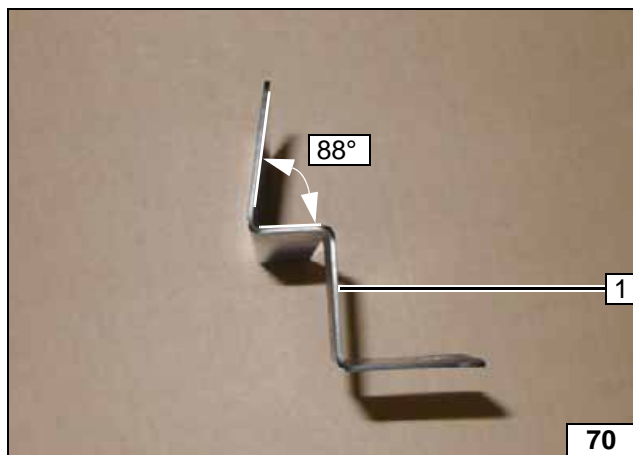

1 Guard plate

Bending guard plate

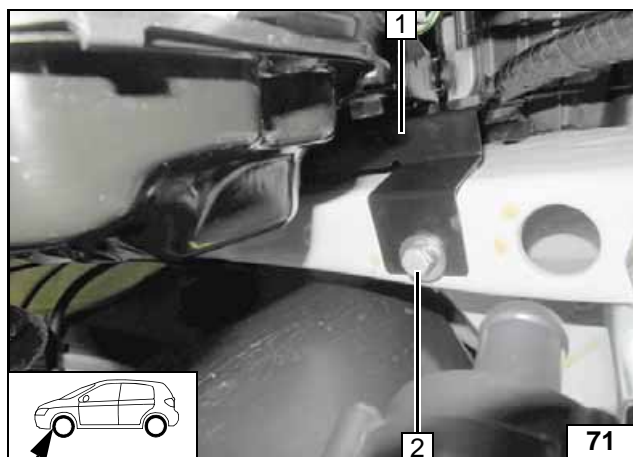

- 1 Guard plate
- 2 M8x20 bolt, spring lockwasher, large diameter washer, existing threaded hole

Installing guard plate

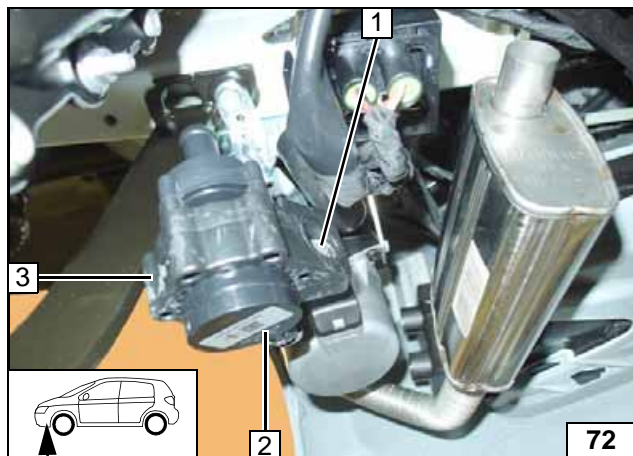

Use lower hole of perforated bracket C.

- 1 M6x25 bolt, flanged nut
- 2 Circulating pump
- 3 Circulating pump mount



Installing circulating pump

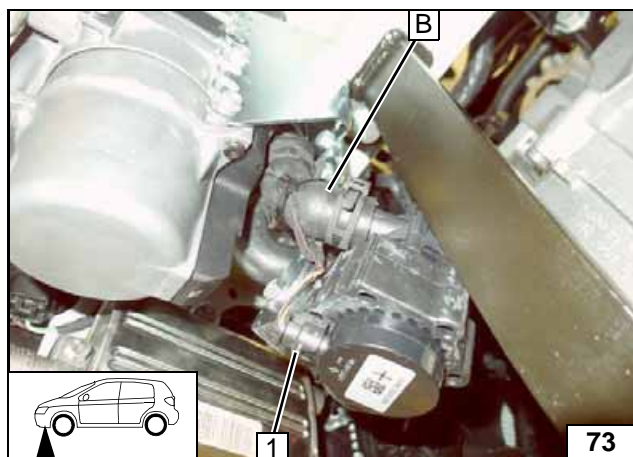

- 1 Connector of circulating pump wiring harness

Connecting circulating pump

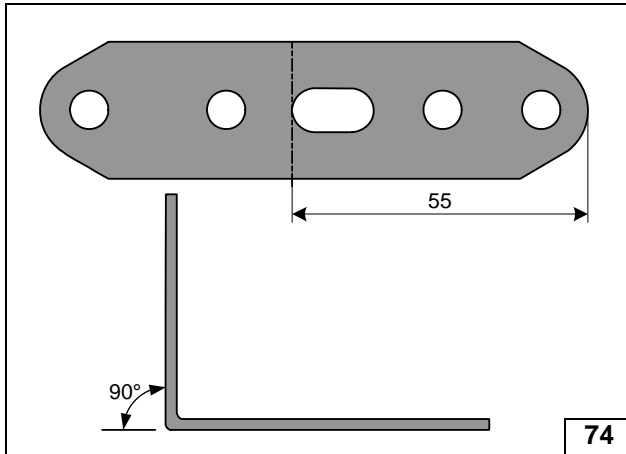

Preparing perforated bracket F

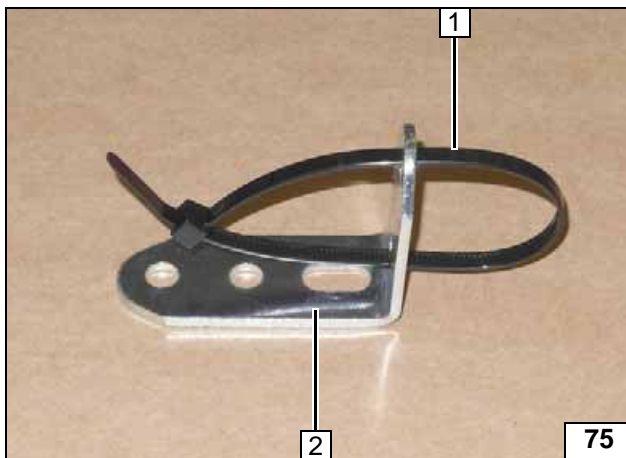

- 1 Cable tie through both holes, don't tighten
- 2 Perforated bracket F

Preparing perforated bracket F

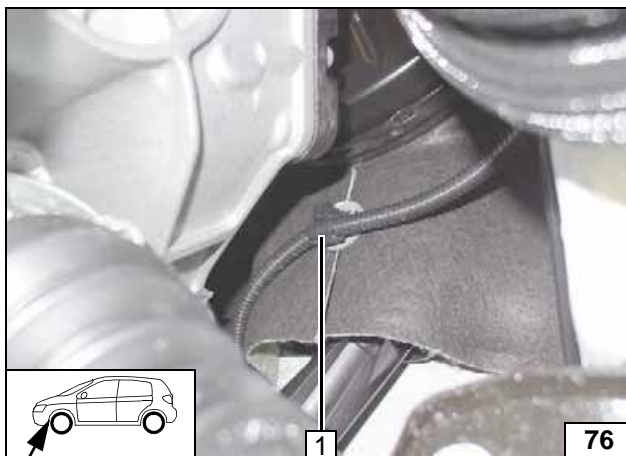

- 1 Discard retaining clamp

Removing retaining clamp

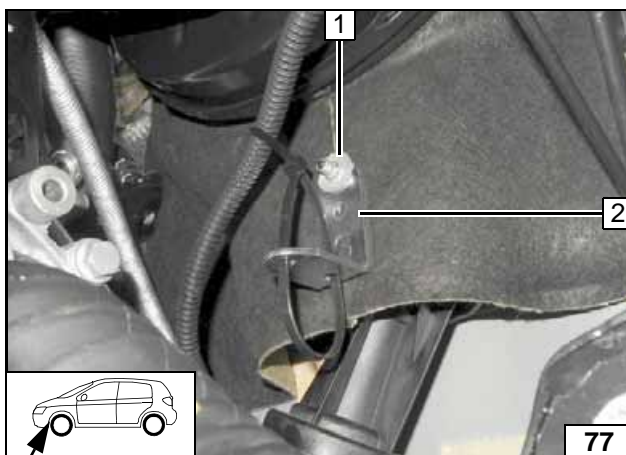

- 1 Plate nut on original vehicle stud bolt
- 2 Perforated bracket F

Installing perforated bracket F

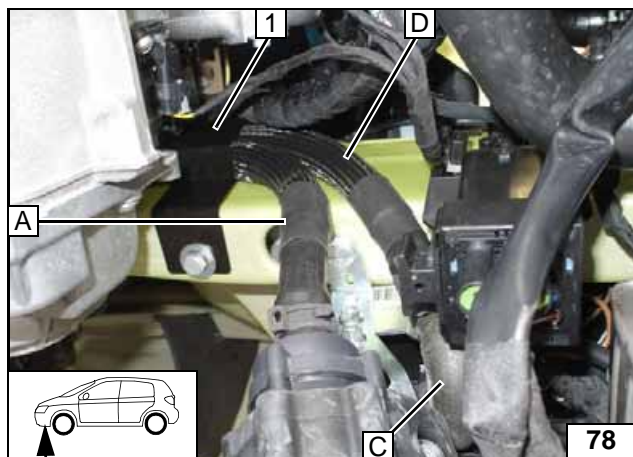

1 Guard plate

Connect-
ing heater

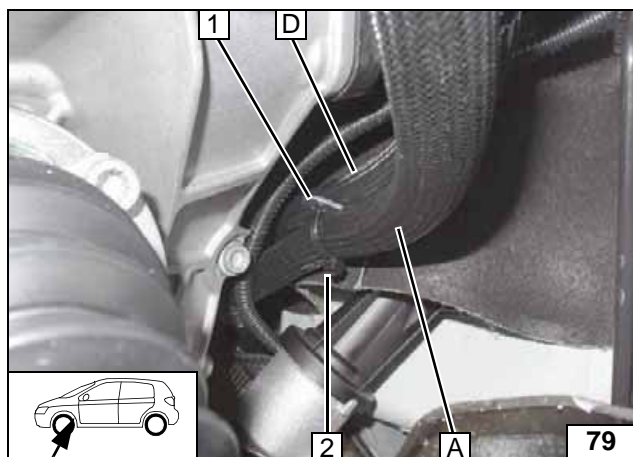

Route hose **D** above and hose **A** under perforated bracket **F 1** through cable tie **2**. Align hoses, tighten cable tie.



Routing in
engine
compartment

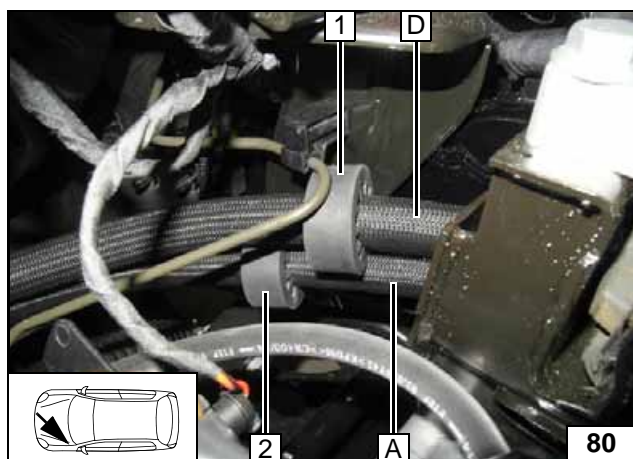

- 1 Align black (sw) rubber isolator with coupling line
- 2 Black (sw) rubber isolator

Routing in
engine
compartment

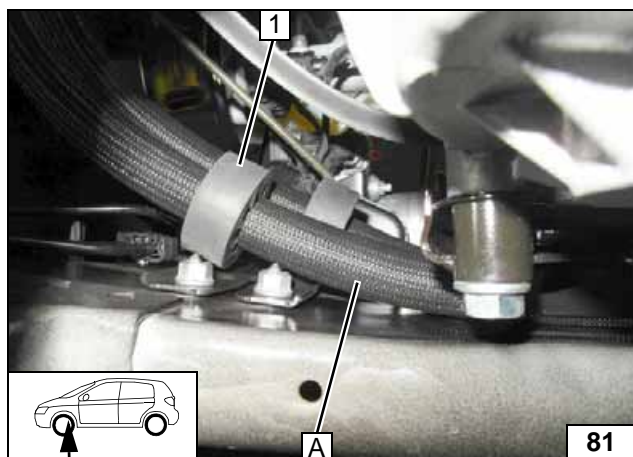

- 1 Align black (sw) rubber isolator with original vehicle bolt

Routing in
engine
compartment

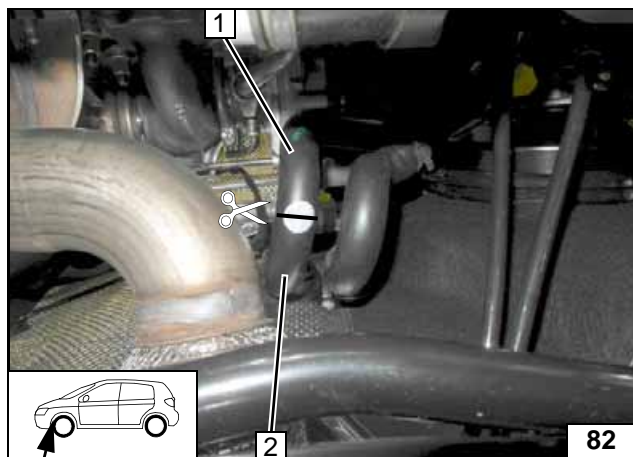

Cut off hose of engine outlet/heat exchanger inlet at the marking.

- 1 Engine outlet hose section
- 2 Heat exchanger inlet hose section

Cutting point

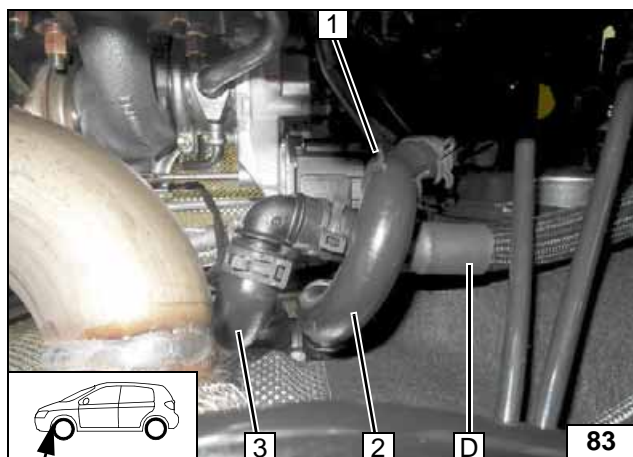

- 1 20x20 hose bracket between hose of heat exchanger outlet 2 and hose D
- 3 Heat exchanger inlet hose section

Connecting heat exchanger inlet

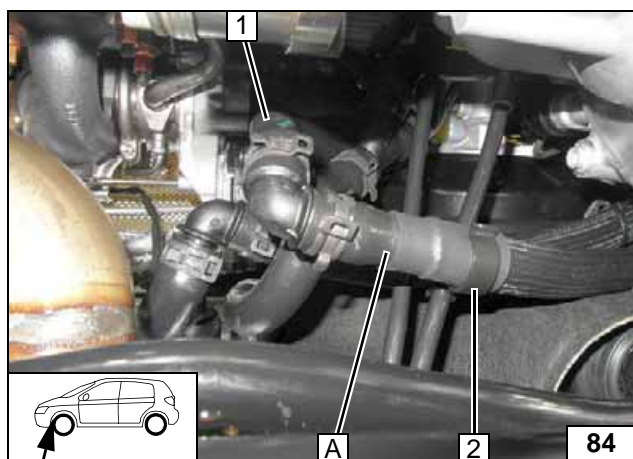

- 1 Engine outlet hose section
- 2 10x20 hose bracket between gear-shift cable and hose A

Connecting engine outlet

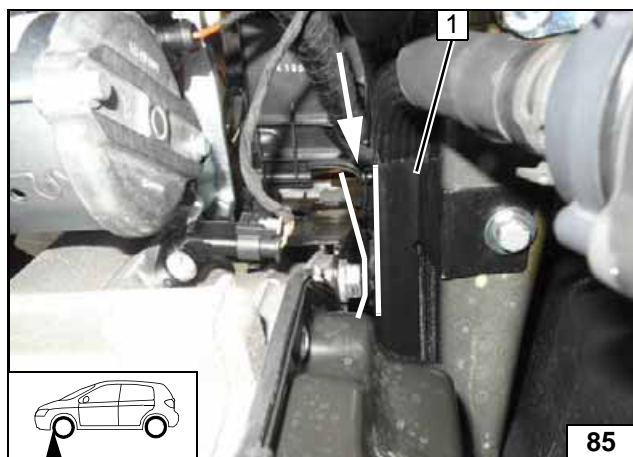

- 1 Guard plate

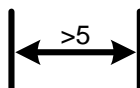

Aligning guard plate

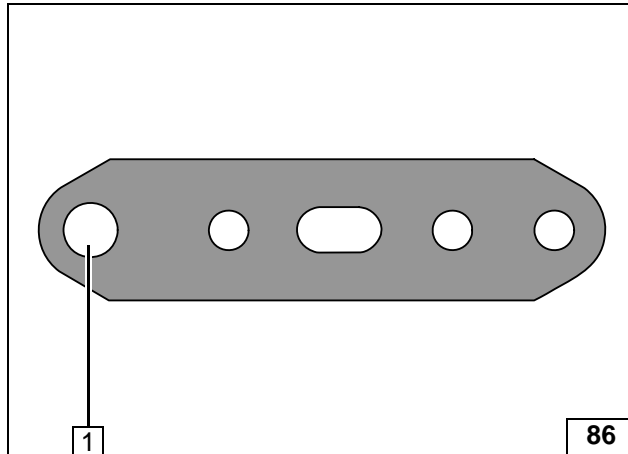
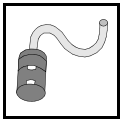

Combustion Air

- 1 Drill hole to 8.5 mm dia.

Preparing perforated bracket G

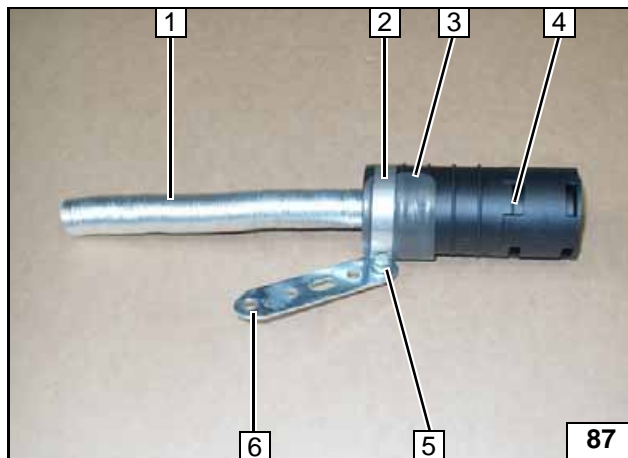

- 1 Combustion air pipe
- 2 51 mm dia. clamp
- 3 Self-adhesive foam strip
- 4 Silencer
- 5 M5x16 bolt, flanged nut
- 6 Perforated bracket G



Premounting combustion air pipe and silencer

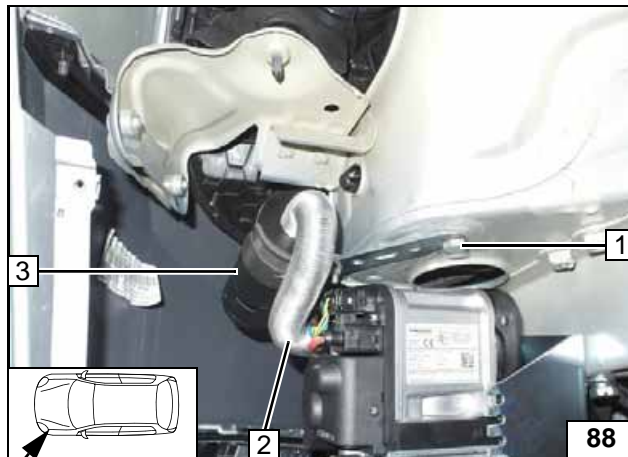

Remove original vehicle bolt at position 1 and discard.

- 1 M8x20 bolt, spring lockwasher, original vehicle thread
- 2 Combustion air pipe
- 3 Silencer



Installing silencer



Fuel



Open the vehicle's fuel tank cap, ventilate the tank and then re-close the tank lock.

Catch any fuel running off in an appropriate container.



Route fuel line and metering pump wiring harness so that they are protected against stone impact. Unless specified otherwise, always fasten using cable ties.

Provide rub protection for fuel line and wiring harness in areas where there are sharp edges.

The fuel line and wiring harness are routed to the metering pump as shown in the wiring harness routing diagram.

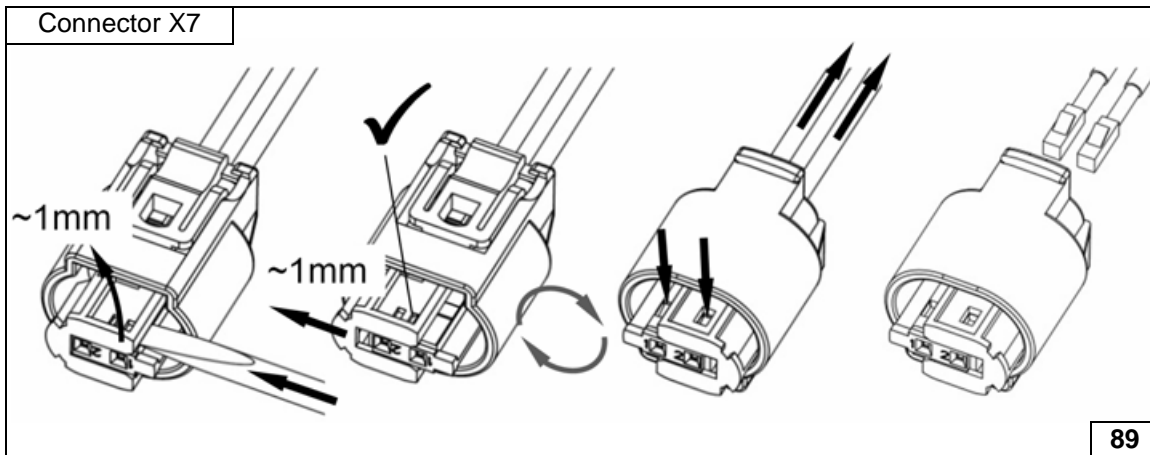

Dismantling metering pump connector

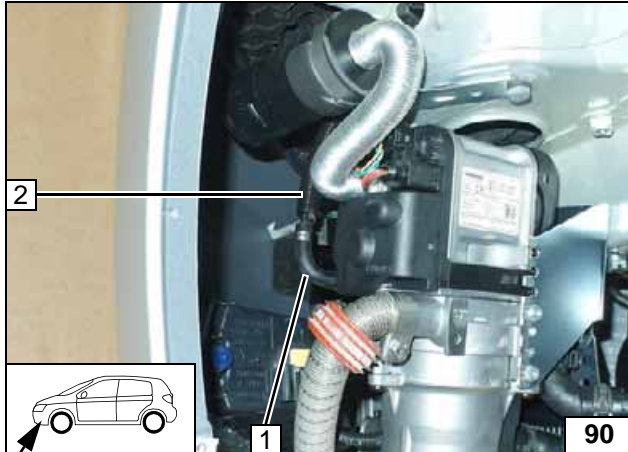

Pull fuel line and wiring harness of metering pump into 10mm dia. corrugated tube **2**. Route 10 mm dia. corrugated tube **2** in the engine compartment and fasten to combustion air pipe using cable ties.

1 90° moulded hose, 10 mm dia. clamp [2x]



Connecting heater



1 Fuel line and wiring harness of metering pump in 10mm dia. corrugated tube

Routing lines

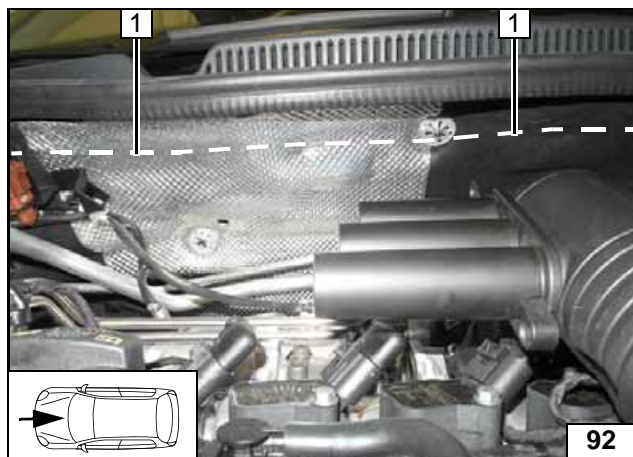

Install coolant reservoir partition wall. Route fuel line and wiring harness metering pump **1** behind the insulation mat at the marking to the right side of the vehicle.



Routing lines

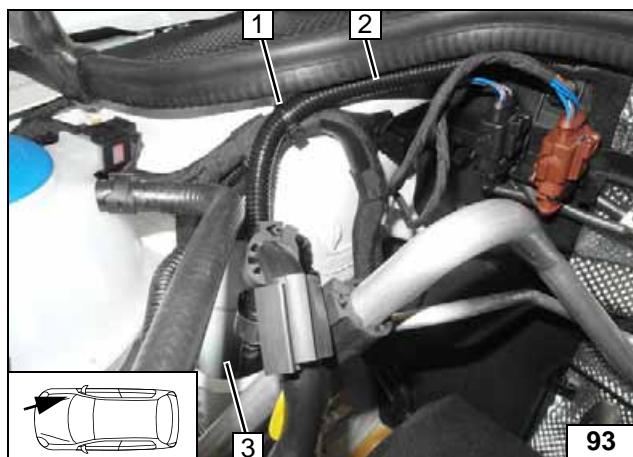

Route fuel line and wiring harness metering pump to the underbody through original vehicle line duct **3**.



Routing lines

- 1** Cable tie
- 2** Fuel line and wiring harness of metering pump in 10mm dia. corrugated tube



- 1** Fuel line, metering pump wiring harness
- 2** Original vehicle pass through for fuel lines

Routing lines

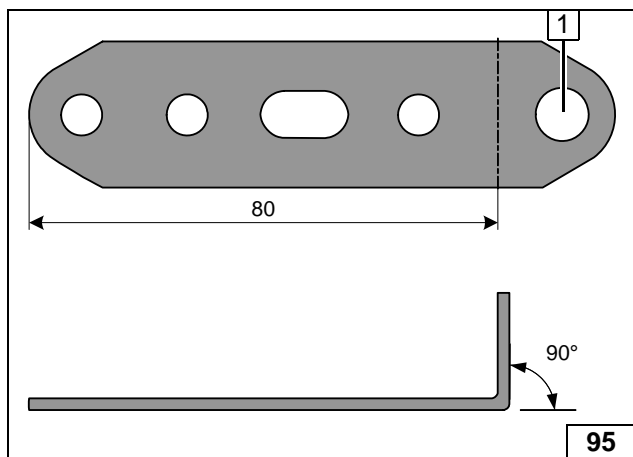

- 1** Drill hole to 8.5 mm dia.

Preparing perforated bracket H

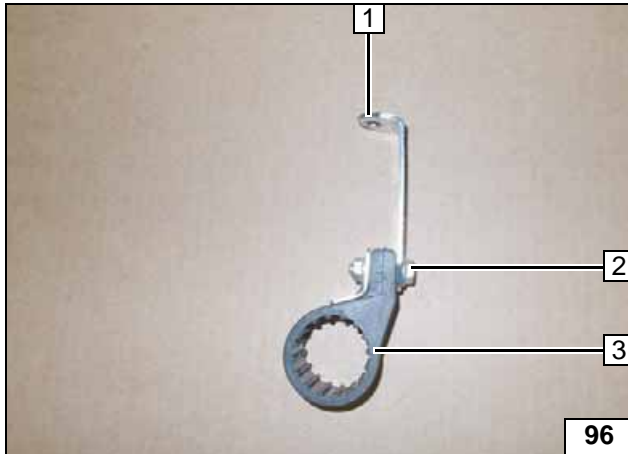
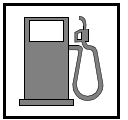

- 1 Perforated bracket H
- 2 M6x25 bolt, support angle bracket, flanged nut
- 3 Metering pump mount

Premounting perforated bracket



- 1 Original vehicle bolt

Installing perforated bracket

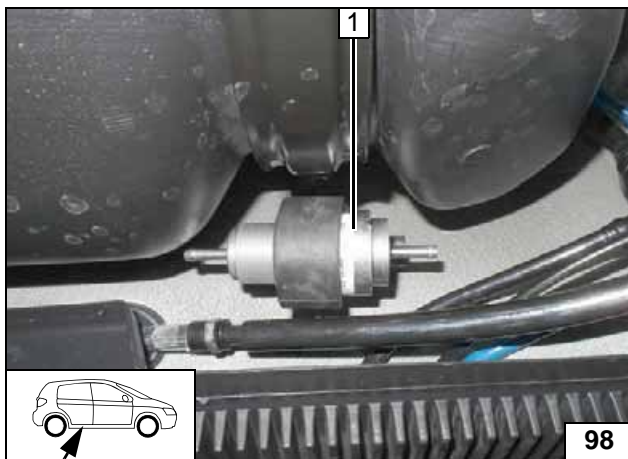

- 1 Metering pump



Installing metering pump

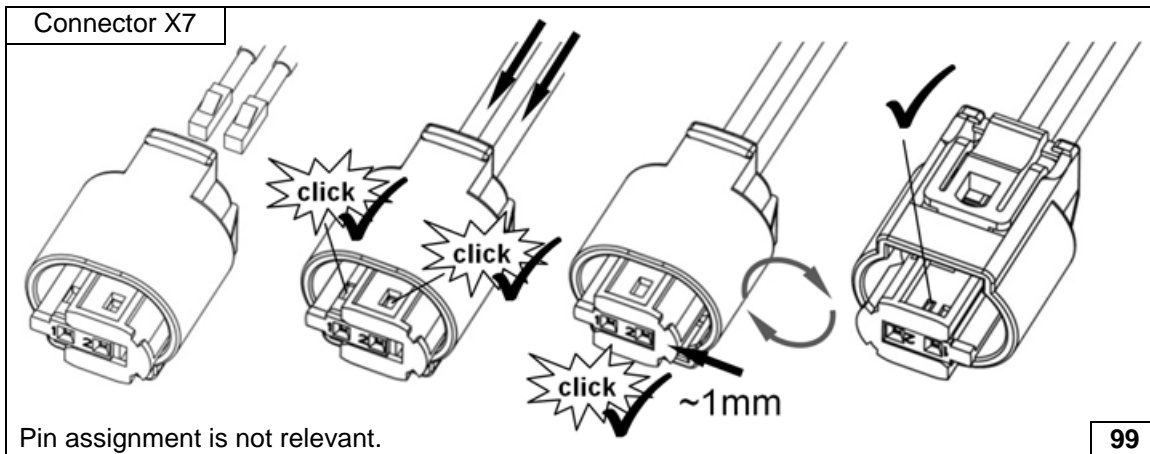

Completing metering pump connector

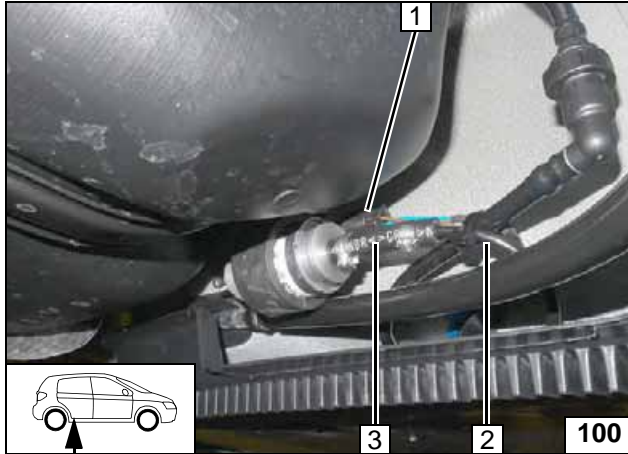
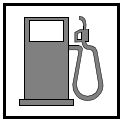

- 1 Metering pump wiring harness, connector X7 mounted
- 2 Fuel line of heater
- 3 Hose section, 10 mm dia. clamp [2x]



**Connect-
ing meter-
ing pump**

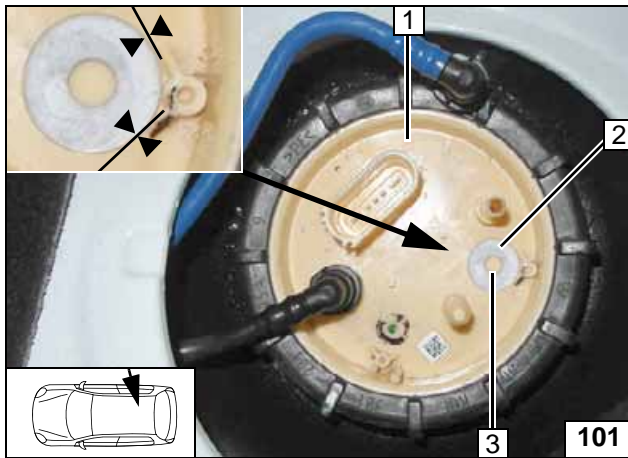

Installing FuelFix for 1.4 TDI

Work steps F1 and F2.

- 1 Fuel tank sending unit
- 2 Position washer with outer dia. $d_a = 21.6\text{mm}$ as template against the raised parts.
- 3 Hole pattern



**Copying
hole pattern**

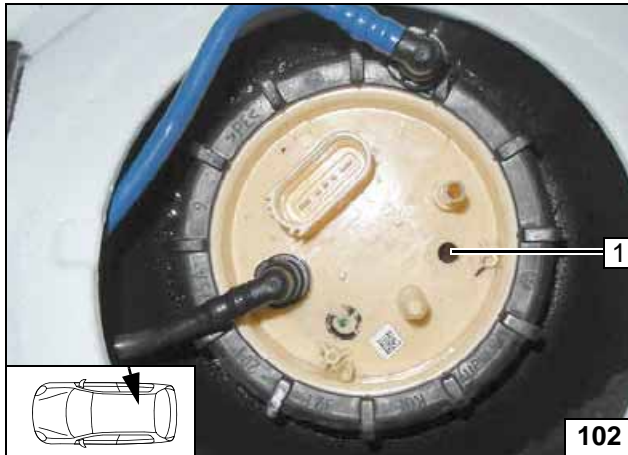

Work step F3.

- 1 Hole made with provided drill

**Hole for
FuelFix**

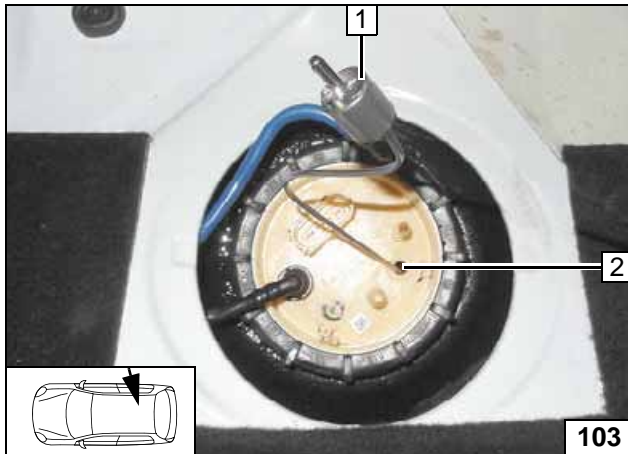

Work steps F4 and F5.

Bend FuelFix 1 according to template and cut to length. Insert into hole 2.



**Inserting
FuelFix**

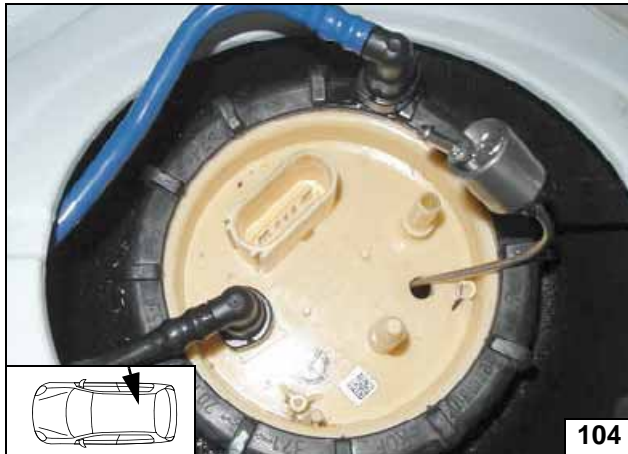

Work step F5.

Inserting FuelFix

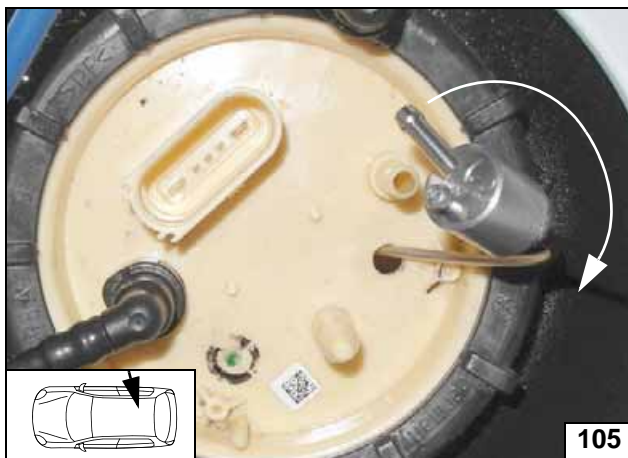

Inserting FuelFix

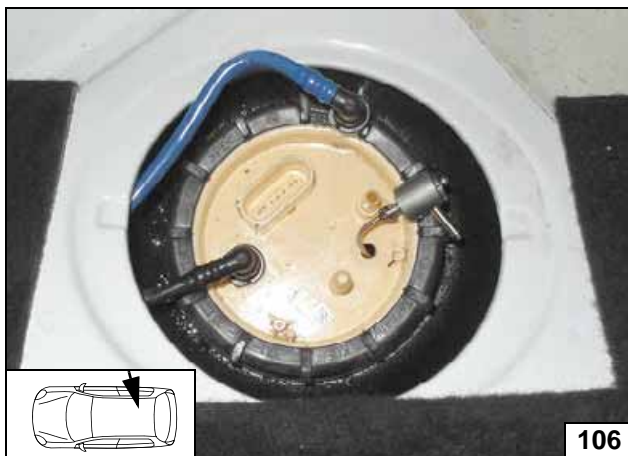

Inserting FuelFix

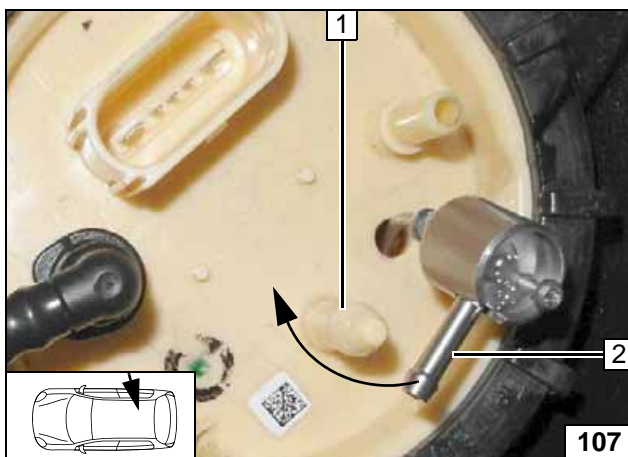

Move FuelFix connection piece 2 over closed stub 1.

Inserting FuelFix

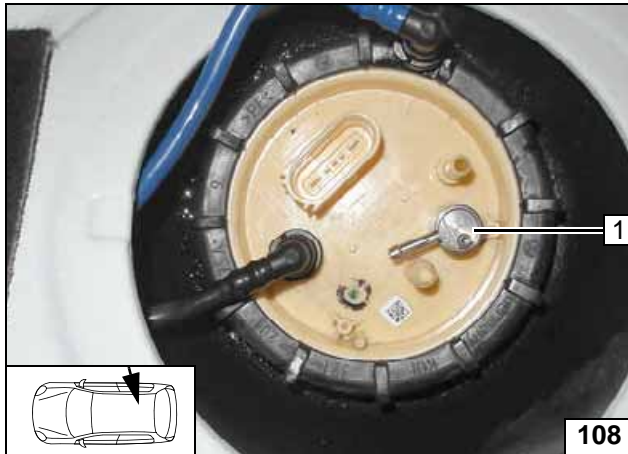
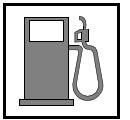

Work steps F5.3 and F5.4.

Align FuelFix 1 as shown.



Aligning FuelFix

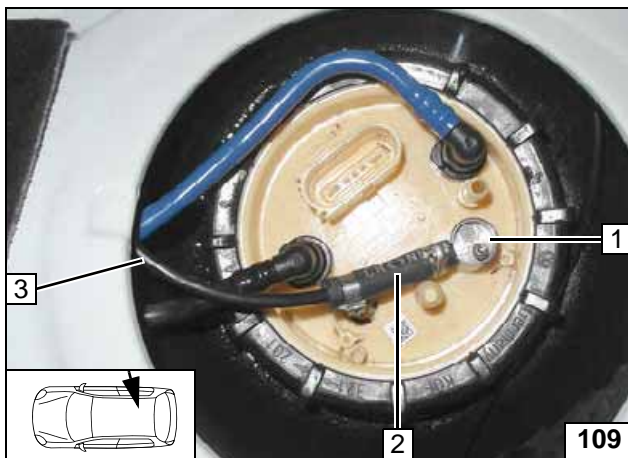

Work step F6.

- 1 FuelFix
- 2 Hose section, 10 mm dia. clamp [2x]
- 3 Fuel line

Connecting fuel line

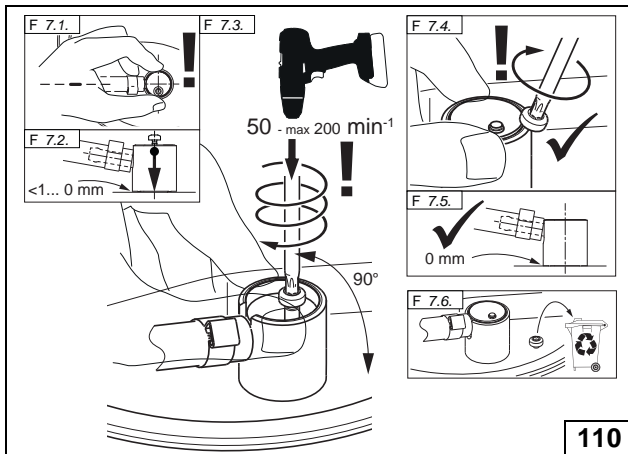

Work step F7.



Installing FuelFix

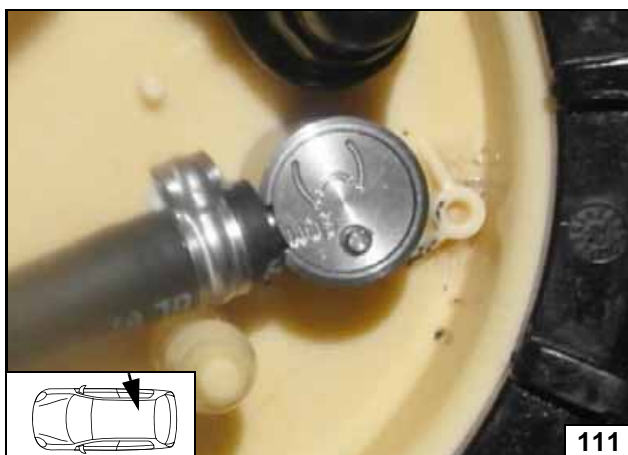

Work step F8.

Ensuring firm seating of FuelFix

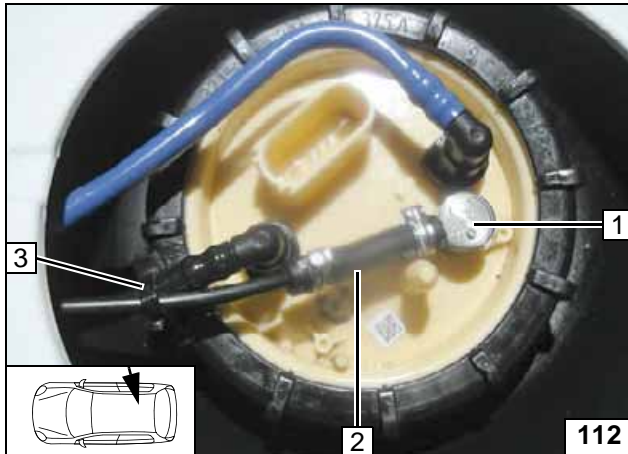
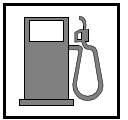

- 1 FuelFix mounted
- 2 Fuel line of FuelFix
- 3 Cable tie as tension relief

Securing fuel line

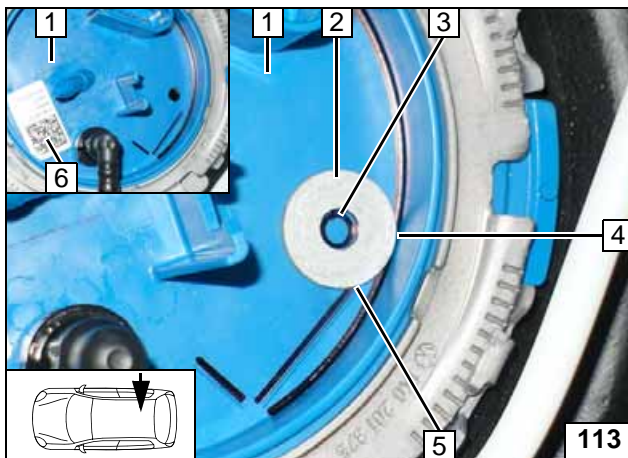

Installing FuelFix for 1.2 TSI

Work steps F1 and F2.

- 1 Fuel tank sending unit
- 2 Position washer with outer dia. $d_a = 21.6\text{mm}$, will be used as a template
- 3 Hole pattern
- 4 Contact point at rim of fuel tank sending unit
- 5 Contact point at end of raised part
- 6 Barcode label, moved



Copying hole pattern



Work step F3.

- 1 Hole made with provided drill

Hole for FuelFix

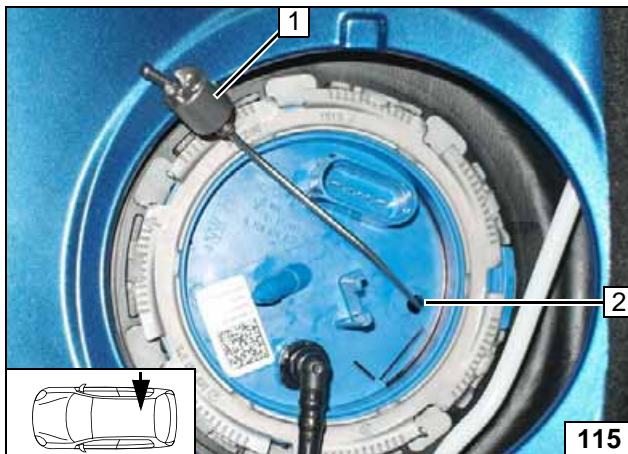

Work steps F4 and F5.

Bend FuelFix 1 according to template and cut to length. Insert into hole 2.



Inserting FuelFix

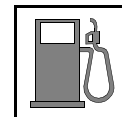

116

Work step F5.

Inserting FuelFix



117

Inserting FuelFix



118

Work steps F5.3 and F5.4.

Align FuelFix 1 as shown.



Aligning FuelFix

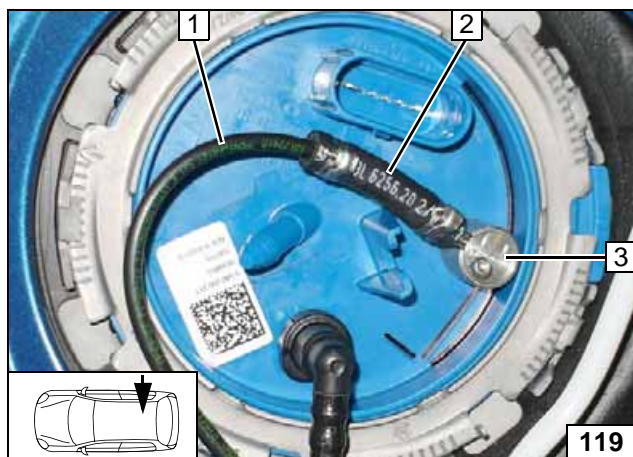

119

Work step F6.

- 1 Fuel line
- 2 Hose section, 10 mm dia. clamp [2x]
- 3 FuelFix

Connecting fuel line



Install original vehicle connector
Align and install FuelFix 1 as shown in the following figure.



Installing FuelFix

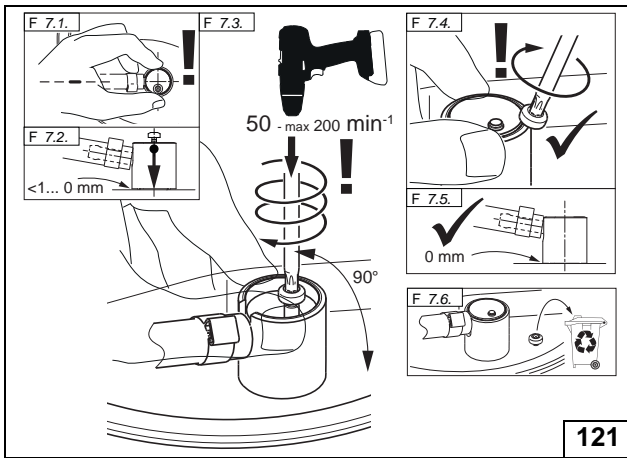

Work step F7.



Installing FuelFix

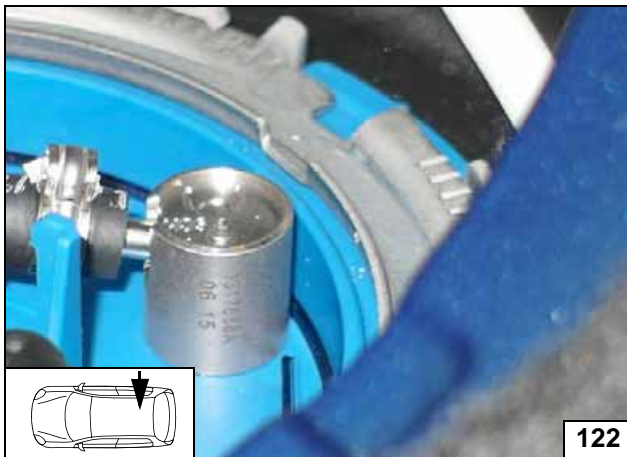

Work step F8.

Ensuring firm seating of FuelFix

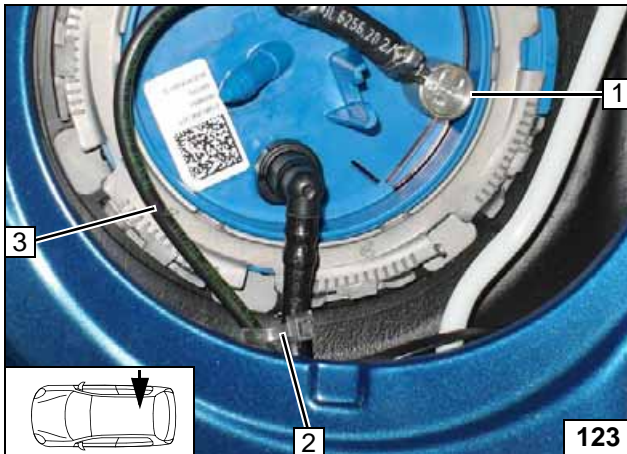

Work step F8.

- 1 FuelFix mounted
- 2 Cable tie as tension relief
- 3 Fuel line of FuelFix

Securing fuel line

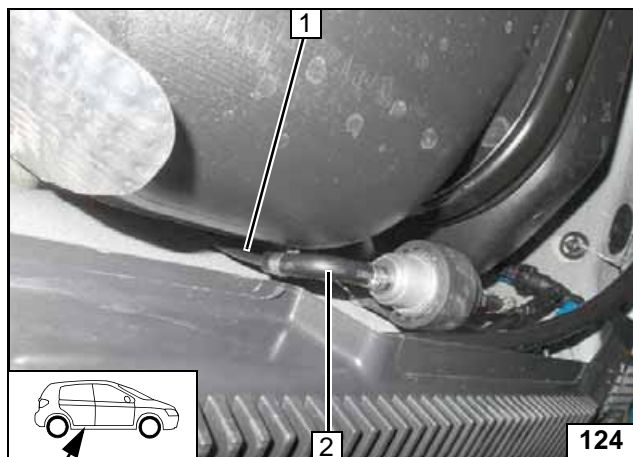

All vehicles

Check the position of the components; adjust if necessary. Check that they have freedom of movement.

- 1 Fuel line of FuelFix
- 2 90° moulded hose, 10 mm dia. clamp [2x]



Connecting metering pump

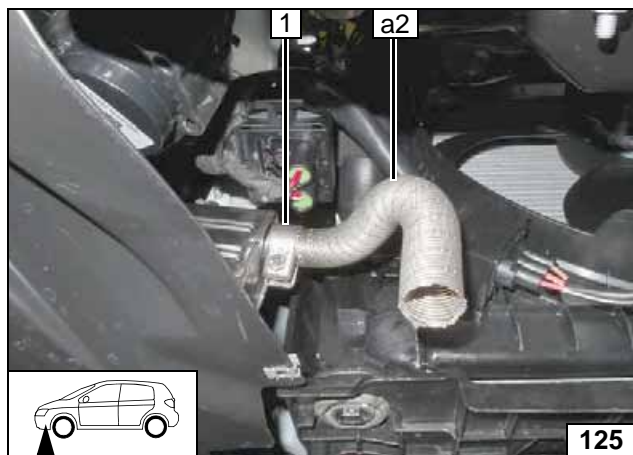
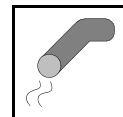

Exhaust Part 2

1.4 TDI

- 1 Hose clamp



Installing exhaust pipe a2

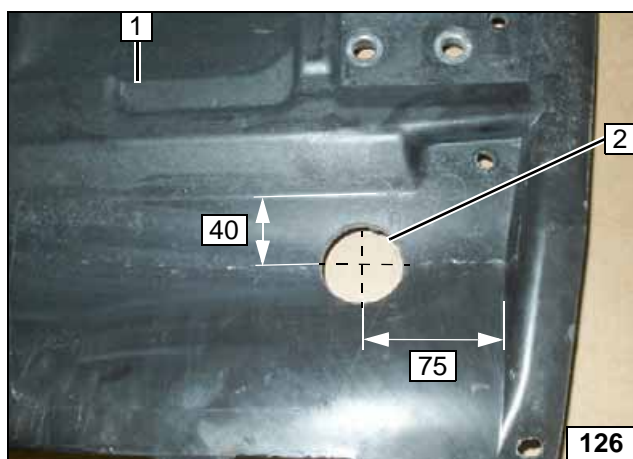

- 1 Underride protection
- 2 Hole (as per work step 1 of the installation instructions)



Hole in underride protection

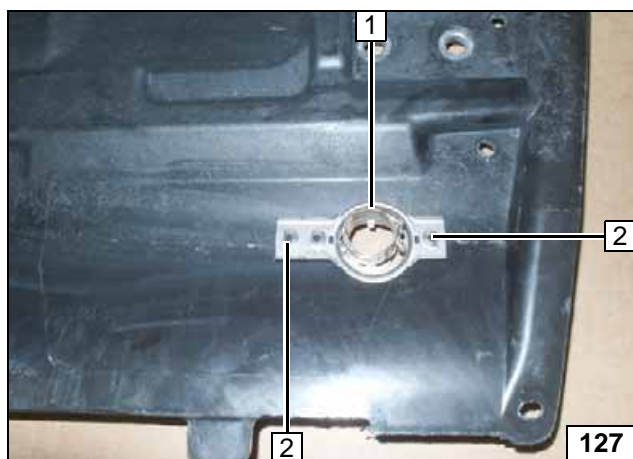

Position exhaust end fastener 1 as per work step 3 of the installation instructions and copy hole pattern 2 [2x].



Copying hole pattern



Hole 1 [2x] as per work step 4 of the installation instructions.



Holes in underride protection

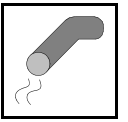

- 1 5x13 self-tapping screw [2x] as per work step 5 of the installation instructions



Installing exhaust end fastener

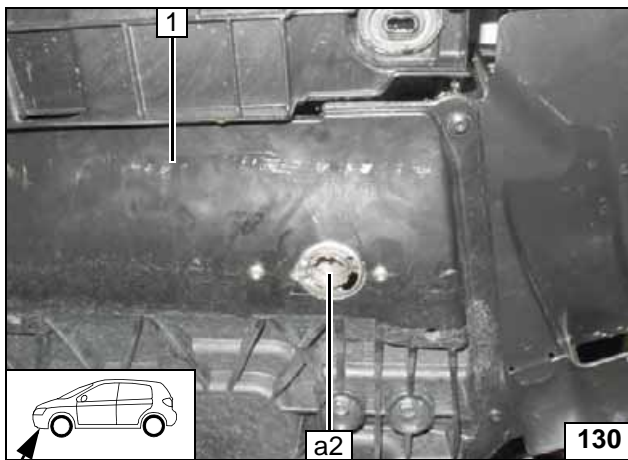

Install underride protection 1. Install exhaust pipe **a2** as per work step 6 - 8 of the installation instructions.



Installing exhaust pipe a2

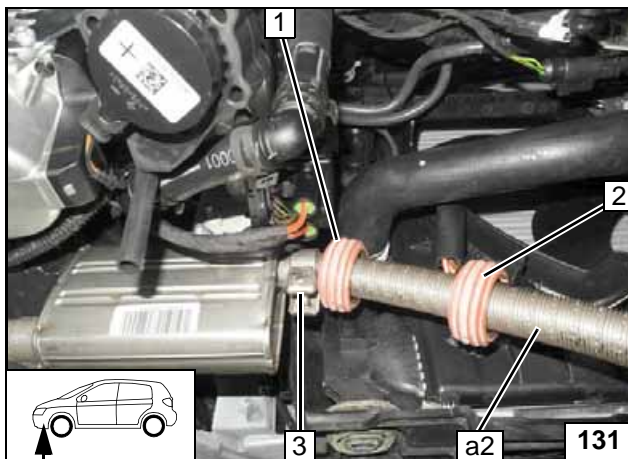

1.2 TSI

- 1 Spacer bracket, align with coolant hose
- 2 Spacer bracket, align with connector
- 3 Hose clamp



Installing exhaust pipe a2

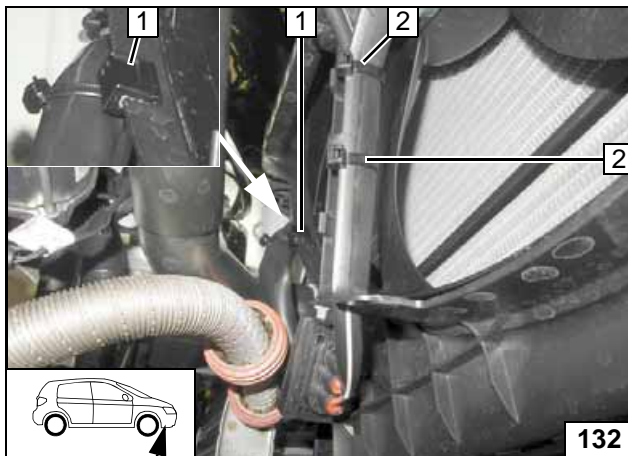

- 1 Clip-type cable tie
- 2 Cable tie [2x]

Attaching wiring harness

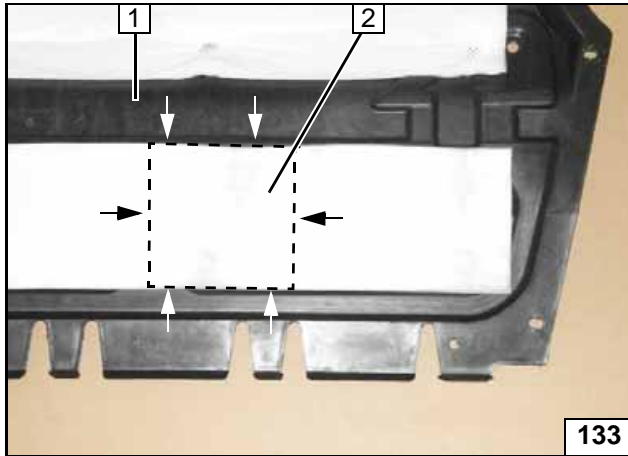

Remove marked area of insulation mat **2** (if present).



- 1 Underride protection

Removing insulation mat

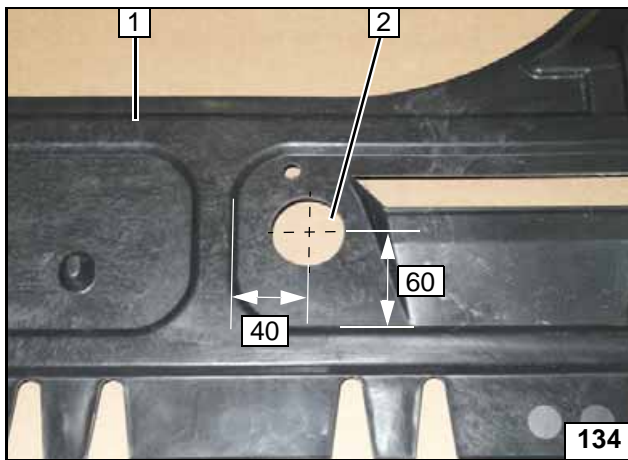

- 1 Underride protection
- 2 Hole (as per work step 1 of the installation instructions)



Hole in underdrive protection

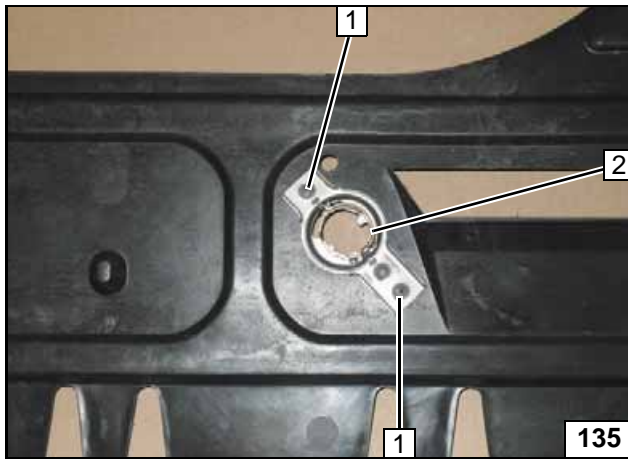

Place exhaust end fastener **2** as per work step 3 of the installation instructions and copy hole pattern **1** [2x].



Copying hole pattern

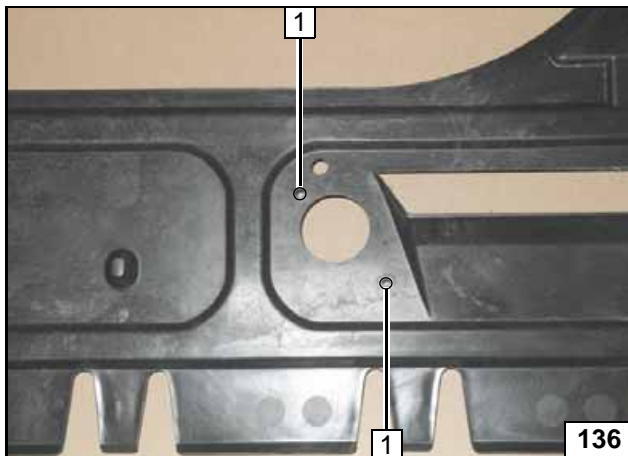

Hole **1** [2x] as per work step 4 of the installation instructions.



Holes in underdrive protection

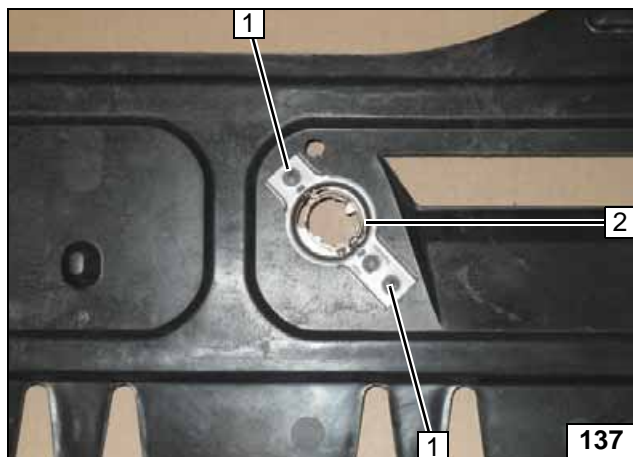
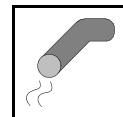

- 1 5x13 self-tapping screw [2x] as per work step 5 of the installation instructions
- 2 Exhaust end fastener



Installing exhaust end fastener

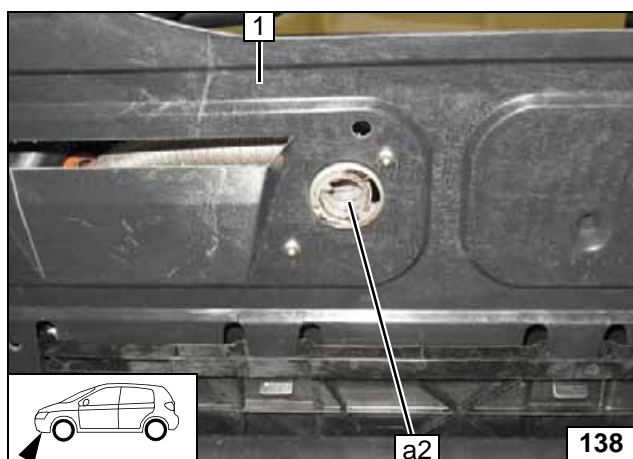

Install underide protection 1.
Install exhaust pipe a2 as per work step 6 - 8 of the installation instructions.



Installing exhaust pipe a2

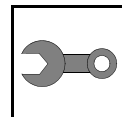

Final Work



Reassemble the components in reverse order. Check all hoses, clamps and all electrical connections for firm seating. Insulate loose wire ends and tie back.
Only use manufacturer-approved coolant. Spray the heater components with anti-corrosion wax (Tectyl 100K).

- **Connect the battery.**
- **Fill and bleed the coolant circuit according to the vehicle manufacturer's specifications.**
- **Program MultiControl CAR, teach Telestart transmitter.**
- **Make settings on the A/C control panel according to the 'Operating Instructions'**
- **Place the 'Switch off parking heater before refuelling' caution label near the filler neck.**
- **For initial startup and function check, please see installation instructions.**

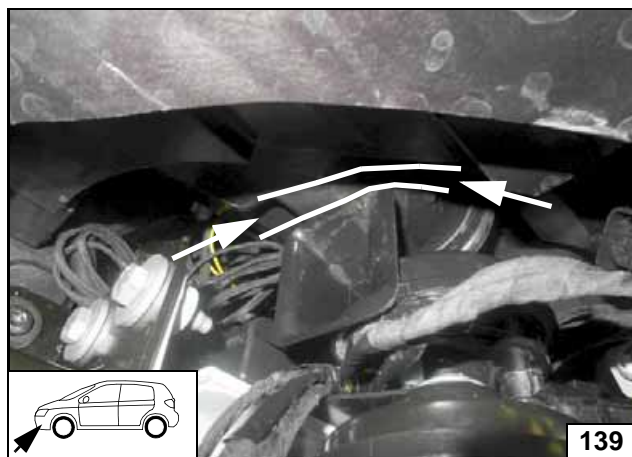

After headlight installation check the distance to the upper horn and after bumper trim installation check the distance between the wiring harnesses for horns, cornering light as well as front fog lights and the exhaust system, correct if necessary.

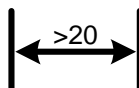

Distance check

Webasto Thermo & Comfort SE
Postfach 1410
82199 Gilching
Germany
Internet: www.webasto.com
Technical Extranet:
<http://dealers.webasto.com>



FuelFix Template for 1.4 TDI

Top view

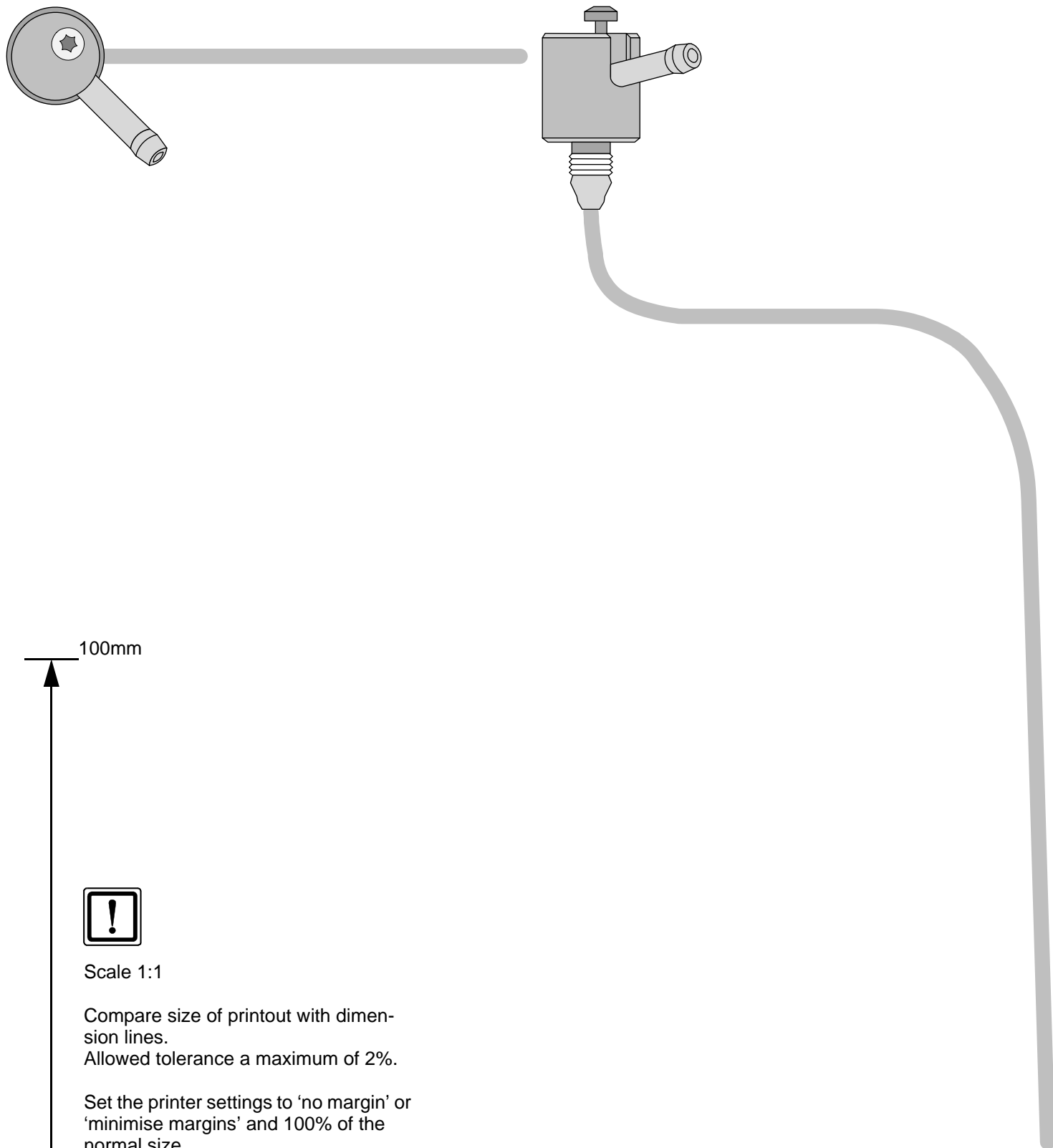

100mm



Scale 1:1

Compare size of printout with dimension lines.
Allowed tolerance a maximum of 2%.

Set the printer settings to 'no margin' or 'minimise margins' and 100% of the normal size.

100mm



FuelFix Template for 1.2 TSI

Top view

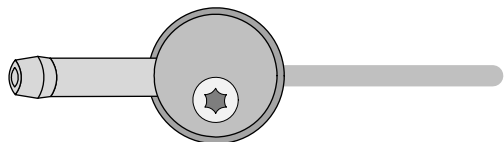

100mm



Scale 1:1

Compare size of printout with dimension lines.
Allowed tolerance a maximum of 2%.

Set the printer settings to 'no margin' or 'minimise margins' and 100% of the normal size.

100mm

Operating Instructions

Please remove page and add to the vehicle operating instructions.

Note:

We recommend matching the heating time to the driving time.

Heating time = driving time

Example:

For a driving time of approx. 20 min. (in one direction), we recommend not exceeding a switch-on time of 20 min.

Passenger compartment monitoring, if installed, must be deactivated in addition to the vehicle settings for the heating operation.

For instructions on deactivation, please refer to the operating instructions of the vehicle.

Before parking the vehicle, make the following settings:

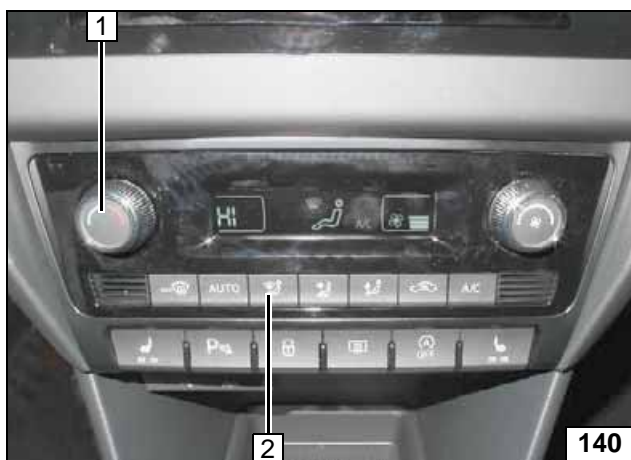

- 1 Set temperature to 'HI'
- 2 Air outlet to windscreen

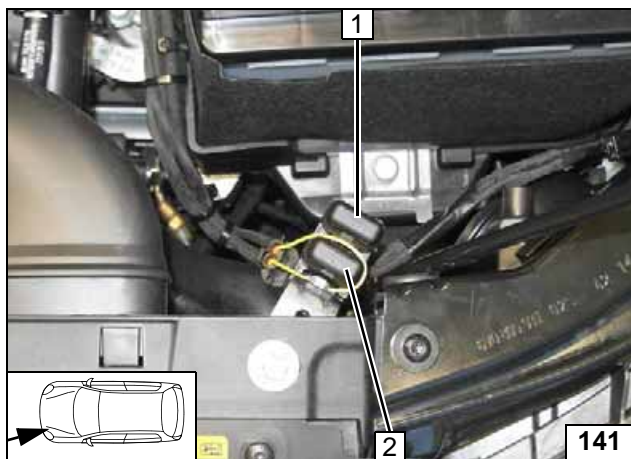

- 1 20A heater fuse F1
- 2 30A passenger compartment main fuse F2

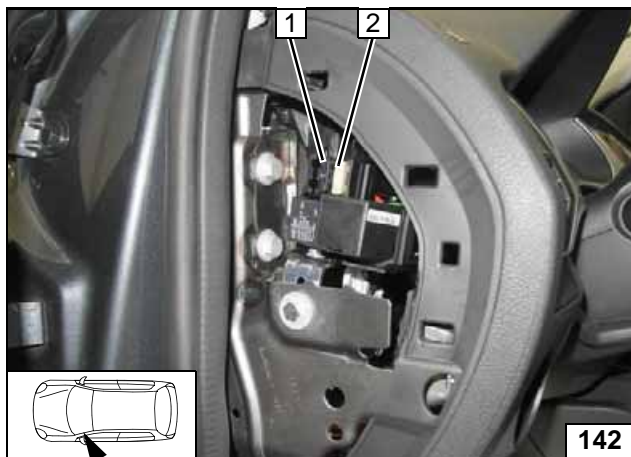

- 1 1A heater control fuse F3
- 2 25A fan fuse F4



A/C control panel

Engine compartment fuses

Passenger compartment fuses

