

# Water Heater

## Thermo Top Evo Parking Heater



With FuelFix

## Installation Documentation MQB

## VW Golf VII / Golf VII Sportsvan / Passat and Skoda Superb

### Validity

Manufacturer	Model	Type	Model year	EG BE No. / ABE
VW	Golf VII	AU	From model year 2013	e1 * 2007 / 46 * 0623 * ...
VW	Golf VII Variant	AU	From model year 2013	e1 * 2007 / 46 * 0627 * ...

Motorisation	Fuel	Emission standard	Transmission type	Output in kW	Displacement in cm <sup>3</sup>	Engine code
1.2 TSI	Petrol	Euro 6	5-speed SG	63	1197	CJZB
1.2 TSI	Petrol	Euro 6	6-speed SG	77	1197	CJZA
1.4 TSI	Petrol	Euro 5	DSG	90	1395	CMBA / CUKA
1.4 TSI	Petrol	Euro 5	6-speed SG	90	1395	CMBA / CXSA
1.4 TSI	Petrol	Euro 5	6-speed SG	103	1395	CHPA
1.4 TSI	Petrol	Euro 5	DSG	103	1395	CPTA
1.6 TDI	Diesel	Euro 5	5-speed SG	77	1598	CLHA
1.6 TDI	Diesel	Euro 5*	6-speed SG	81	1598	CRKB
2.0 TDI	Diesel	Euro 5*	DSG	110	1968	CRBC

Manufacturer	Model	Type	Model year	EG BE No. / ABE
VW	Golf VII Sportsvan	AUV	From model year 2014	e1 * 2007 / 46 * 0627 * ...

Motorisation	Fuel	Emission standard	Transmission type	Output in kW	Displacement in cm <sup>3</sup>	Engine code
1.2 TSI	Petrol	Euro 6	5-speed SG	63	1197	CJZB
1.4 TSI	Petrol	Euro 6	DSG	92	1395	CZCA
1.6 TDI	Diesel	Euro 5	5-speed SG	81	1598	CRKB
1.6 TDI (BlueMotion)	Diesel	Euro 6	6-speed SG	81	1598	CRKB
2.0 TDI (BlueMotion)	Diesel	Euro 6	DSG	110	1968	CRLB

SG = manual transmission

DSG = direct gear transmission

### Left-hand drive vehicle

**Verified equipment variants:** \*Euro 6 in case of Blue TDi  
 Climatic (only for Golf VII)  
 Climatronic  
 Front fog lights  
 Start - Stop ( only for Golf VII)  
 Passenger compartment monitoring (can be turned off)  
 Xenon / headlight washer system

**Not verified:** Passenger compartment monitoring  
 4Motion

**Exclusion:** Heavy-duty running gear incl. stoneguard

**Total installation time:** approx. 7 hours

## VW Golf VII / Golf VII Sportsvan / Passat and Skoda Superb

Manufacturer	Model	Type	Model year	EG BE No. / ABE
VW	Passat / Passat Variant	3C / 3G	From model year 2015	e1 * 2001 / 116 * 0307 * ...

Motorisation	Fuel	Emission standard	Transmission type	Output in kW	Displacement in cm <sup>3</sup>	Engine code
1.4 TSI	Petrol	Euro 6	DSG	110	1395	CZEA
2.0 TDI	Diesel	Euro 5*	DSG	110	1968	CRLB
2.0 TDI	Diesel	Euro 5*	DSG	140	1968	DDAA

DSG = direct gear transmission

### Left-hand drive vehicle

**Verified equipment variants:** \*Euro 6 in case of Blue TDi  
 Climatronic  
 Front fog lights  
 Start - Stop  
 Turning light  
 LED headlight  
 Headlight washer system (diesel only)

**Not verified:**  
 Climatic  
 Passenger compartment monitoring  
 Headlight washer system (petrol only)  
 Rough road package

**Exclusion:** 4Motion

**Total installation time:** approx. 7.5 hours

Manufacturer	Model	Type	Model year	EG BE No. / ABE
Skoda	Superb	3T / 3V	From model year 2015	e11 * 2001 / 116 * 0326 * ...

Motorisation	Fuel	Emission standard	Transmission type	Output in kW	Displacement in cm <sup>3</sup>	Engine code
1.4 TSI	Petrol	Euro 6	6-speed SG	110	1395	CZEA
1.6 TDI	Diesel	Euro 6	DSG	88	1598	DCXA
2.0 TDI	Diesel	Euro 6	6-speed SG	110	1968	CRLB
2.0 TDI	Diesel	Euro 6	DSG	110	1968	CRLB
2.0 TDI	Diesel	Euro 6	DSG	140	1968	DFCA

SG = manual transmission

DSG = direct gear transmission

### Left-hand drive vehicle

**Verified equipment variants:** Automatic air-conditioning  
 Multi-zone automatic air-conditioning  
 Front fog lights  
 Start - Stop  
 Xenon headlights  
 Turning light  
 Headlight washer system  
 4x4

**Not verified:**  
 Manual air-conditioning  
 Passenger compartment monitoring

**Total installation time:** approx. 7.5 hours

# VW Golf VII / Golf VII Sportsvan / Passat and Skoda Superb

## Table of Contents

Validity	1	Preparing Installation Location	17
Necessary Components	3	Installing Heater Assembly	18
Installation Instructions	3	Fuel	21
Information on Total Installation Time	3	FuelFix Installation for TSI	23
Information on Operating and Installation Instructions	4	Installing FuelFix for Golf VII / Golf VII Sportsvan TDI	26
Information on Validity	5	Installing FuelFix for Passat / Superb TDI Front-Wheel Drive	29
Technical Information	5	Installing FuelFix for Superb TDI 4x4	32
Explanatory Notes on Document	5	TSI Coolant Circuit	36
Preliminary Work for Golf VII / Golf VII Sportsvan	6	Coolant Circuit for TDI Front-Wheel Drive	42
Preliminary Work for Passat	6	Coolant Circuit for Superb 2.0 TDI 4x4 and 1.6 TDI	46
Preliminary Work for Superb	7	Final Work	50
Heater Assembly Installation Location	7	FuelFix Template for TSI	51
Preparing Electrical System	8	FuelFix Template for TDI Golf VII / Golf VII Sportsvan	52
Electrical System	10	FuelFix Template for TDI Passat / Superb Front-Wheel Drive	53
Air-Conditioning Control	11	FuelFix Template for TDI Superb 4x4	54
Heater Control Elements for Golf VII	11		
Heater Control Elements for Sportsvan	13		
Passat / Superb Heater Controls	14		

## Necessary Components

Description	Order No.:
Delivery scope of Golf / Passat / Superb petrol 2013 TT-Evo	1325112A
Delivery scope of Golf / Passat / Superb diesel 2013 TT-Evo	1325110A
Additional kit 'Webasto Standard' for VW / Skoda MQB with AAC or Additional kit 'Webasto Comfort' for VW / Skoda MQB with AAC	1325085_ 1325012_
In case of Telestart, heater control, as well as indicator lamp in consultation with end customer	In accordance with price list
In case of installation of MultiControl CAR - MultiControl installation frame	9030077_

## Webasto Individual Option

Description	Order No.:
Webasto Individual Auxiliary Heating additional kit	1320077_
Webasto Individual Quick additional kit	9030826_
Webasto Individual Select additional kit	9030828_

## Installation Instructions

Arrange for the vehicle to be delivered with the tank only about ¼ full.

The installation location of the push button in case of Telestart or ThermoCall should be confirmed with the end customer.

Depending on the space required and the vehicle manufacturer's instructions, we recommend the use of a vehicle battery with a higher electrical capacity.

Ensure sufficient distance from original vehicle components when installing the premounted heater assembly, correct if necessary.

### Golf VII / Golf VII Sportsvan

Pictures used for the installation steps are of a 1.6TDI vehicle. Deviations are documented separately!

### Passat / Superb

Pictures used for the installation steps are of a 2.0TDI (2WD) vehicle. Deviations are documented separately!

## Information on Total Installation Time

The total installation time includes the time needed for mounting and demounting the vehicle-specific components, the heater specific installation time and all other times required for the system integration and initial start-up of the heater.

The total installation time may vary for vehicle equipment other than provided.

## Information on Operating and Installation Instructions

### 1 Important information (not complete)

#### 1.1 Installation and repair



The improper installation or repair of Webasto heating and cooling systems can cause fire or the leakage of deadly carbon monoxide, leading to serious injury or death.



To install and repair Webasto heating and cooling systems you need to have completed a special company training course and have the appropriate technical documentation, special tools and special equipment.



Installation and repair may ONLY be carried out by persons trained and certified in a Webasto training course. NEVER try to install or repair Webasto heating or cooling systems if you have not completed a Webasto training course, you do not have the necessary technical skills and you do not have the technical documentation, tools and equipment available to ensure that you can complete the installation and repair work properly.

Only use genuine Webasto parts. See the Webasto air and water heaters accessories catalogue for this purpose.

#### 1.2 Operation

To ensure safe operation, we recommend having the heater checked every two years by an authorised Webasto dealer, especially when used over a long period and/or under extreme environmental conditions.

Do not operate the heater in closed rooms due to the danger of poisoning and suffocation.

Always switch off the heater before refuelling.

The heater may only be used with the prescribed fuel diesel (DIN EN 590) or petrol (DIN EN 228).

The heater may not be cleaned with a high-pressure cleaner.

#### 1.3 Please note

ALWAYS follow all Webasto installation and operating instructions and observe all warnings.

To become familiar with and understand all functions and properties of the heater, the operating instructions must be read carefully and observed at all times.

For proper, safe installation and repair work, the installation instructions with all warnings and safety information must be carefully read and observed at all times. Please always contact a workshop authorised by Webasto for all installation and repair work.

#### Important

**Webasto shall assume no liability for defects, damage and injuries resulting from a failure to observe the installation, repair and operating instructions of the information contained in them.**

**This liability exclusion particularly applies to improper installations and repairs, installations and repairs by untrained persons or in the case of a failure to use genuine spare parts.**

**The liability due to culpable disregard to life, limb or health and due to damage or injuries caused by a wilful or reckless breach of duty remain unaffected, as does the obligatory product liability.**

Installation should be carried out according to the general, standard rules of technology. Unless specified otherwise, fasten hoses, lines and wiring harnesses to original vehicle lines and wiring harnesses using cable ties. Insulate loose wire ends and tie back. Connectors on electronic components must audibly snap into place during assembly.

Sharp edges should be fitted with rub protection. Spray unfinished body areas, e.g. drilled holes, with anti-corrosion wax (Tectyl 100K).

Observe the instructions and guidelines of the respective vehicle manufacturer for demounting and mounting vehicle specific components!

The initial startup is to be executed with the Webasto Thermo Test Diagnosis.

When installing a programmable control module (e.g. a PWM Gateway), the corresponding settings must be checked or adjusted.

### 2 Statutory regulations governing installation

Guidelines	Thermo Top Evo
Heating Directive ECE R122	E1 00 0258
EMC Directive ECE R10	E1 04 5627

#### Note

The regulations of these guidelines are binding in the scope of the Directive 70/156/EEC and/or 2007/46/EC (for new vehicle models from 29/04/2009) and should also be observed in countries in which there are no special regulations.

#### Important

Failure to follow the installation instructions will result in the invalidation of the type approval for the heater and therefore invalidation of the general **homologation of the vehicle**.

#### Note

The heater is licensed in accordance with paragraph 19, section 3, No. 2b of the StVZO (German Road Traffic Licensing Authority).

### 2.1 Excerpt from ECE regulation 122 (heating system) paragraph 5 for the installation of the heater

Beginning of excerpt.

#### ANNEX VII

#### REQUIREMENTS FOR COMBUSTION HEATERS AND THEIR INSTALLATION

##### 1. GENERAL REQUIREMENTS

1.7.1. A clearly visible tell-tale in the operator's field of view shall inform when the combustion heater is switched on or off.

##### 2. VEHICLE INSTALLATION REQUIREMENTS

###### 2.1. Scope

2.1.1. Subject to paragraph 2.1.2, combustion heaters shall be installed according to the requirements of this Annex.

2.1.2. Vehicles of category O having liquid fuel heaters are deemed to comply with the requirements of this Annex.

###### 2.2. Positioning of heater

2.2.1. Body sections and any other components in the vicinity of the heater must be protected from excessive heat and the possibility of fuel or oil contamination.

2.2.2. The combustion heater shall not constitute a risk of fire, even in the case of overheating. This requirement shall be deemed to be fulfilled if the installation ensures an adequate distance to all parts and suitable ventilation, by the use of fire resistant materials or by the use of heat shields.

2.2.3. In the case of M2 and M3 vehicles, the heater must not be positioned in the passenger compartment. However, an installation in an effectively sealed envelope which also complies with the conditions in paragraph 2.2.2 may be used.

2.2.4. The label referred to in paragraph 1.4 or a duplicate, must be positioned so that it can be easily read when the heater is installed in the vehicle.

2.2.5. Every reasonable precaution should be taken in positioning the heater to minimise the risk of injury and damage to personal property.

###### 2.3. Fuel supply

2.3.1. The fuel filler must not be situated in the passenger compartment and must be provided with an effective cap to prevent fuel spillage.

2.3.2. In the case of liquid fuel heaters, where a supply separate to that of the vehicle is provided, the type of fuel and its filler point must be clearly labelled.

2.3.3. A notice, indicating that the heater must be shut down before refuelling, must be affixed to the fuelling point. In addition a suitable instruction must be included in the manufacturer's operating manual.

###### 2.4. Exhaust system

2.4.1. The exhaust outlet must be located so as to prevent emissions from entering the vehicle through ventilators, heated air inlets or opening windows.

###### 2.5. Combustion air inlet

2.5.1. The air for the combustion chamber of the heater must not be drawn from the passenger compartment of the vehicle.

2.5.2. The air inlet must be so positioned or guarded that blocking by rubbish or luggage is unlikely.

###### 2.6. Heating air inlet

2.6.1. The heating air supply may be fresh or recirculated air and must be drawn from a clean area not likely to be contaminated by exhaust fumes emitted either by the propulsion engine, the combustion heater or any other vehicle source.

2.6.2. The inlet duct must be protected by mesh or other suitable means.

###### 2.7. Heating air outlet

2.7.1. Any ducting used to route the hot air through the vehicle must be so positioned or protected that no injury or damage could be caused if it were to be touched.

2.7.2. The air outlet must be so positioned or guarded that blocking by rubbish or luggage is unlikely.

End of excerpt.

In multilingual versions the German language is binding.

## Information on Validity

This installation documentation applies to Petrol and diesel vehicles- for validity, see page 1 - from model year 2013 and later, assuming technical modifications to the vehicle do not affect installation, any liability claims excluded. Depending on the vehicle version and equipment, modifications may be necessary during installation with respect to this 'installation documentation'.

Vehicle and engine types, equipment variants and other specifications not listed in this installation documentation have not been tested. However, installation according to this installation documentation may be possible.

## Technical Information

### Special Tools

- Hose clamp pliers for auto-tightening hose clamps
- Hose clamp pliers for Clic hose clamps of type W
- Automatic wire stripper, 0.2 - 6mm<sup>2</sup>
- Crimping pliers for cable lug / tab connector, 0.5 - 6mm<sup>2</sup>
- Torque wrench for 2.0 - 10 Nm
- Hose clamping pliers
- Metric thread-setter kit
- Deep-hole marker
- Webasto Thermo Test Diagnosis with current software

### Dimensions

- All dimensions are in mm.

### Tightening torque values

- Tighten bolt connections in accordance with manufacturer's instructions or in accordance with state-of-the-art-technology.

## Explanatory Notes on Document

You will find an identification mark on the outside top right corner of the page in question to provide you with a quick overview of the individual working steps.

### Mechanics



### Electrics



### Coolant Circuit



### Combustion Air

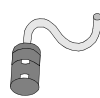

### Fuel



### Exhaust Gas



### Software



Special features are highlighted using the following symbols:

Specific risk of damage to components.



Specific risk due to electrical voltage.



Specific risk of fire or explosion.



Reference to a special technical feature.



The arrow in the vehicle icon indicates the position on the vehicle and the viewing angle.

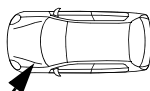

Reference to the manufacturer's vehicle-specific documents.



Reference to specific installation instructions of Webasto components (demonstrated with the example of the FuelFix).



Reference to general installation instructions of Webasto components.



Tightening torque according to the manufacturer's vehicle-specific documents.



## Preliminary Work for Golf VII / Golf VII Sportsvan

### Vehicle

- Open the fuel tank cap.
- Ventilate the fuel tank.
- Close the fuel tank cap again.
- Depressurise the cooling system.
- Disconnect and remove the battery completely together with the carrier.
- Completely remove the air filter box together with the intake hose.
- Remove the engine underride protection.
- Remove the right underride protection.
- Remove the fuel tank underride protection, if present.
- Remove the right front wheel.
- Remove the front right wheel well trim.
- Remove the lateral instrument panel trim on the driver's side (in case of Telestart).
- Remove the A-pillar trim on the driver's side (in case of Telestart).
- Remove the footwell trim on the front passenger's side.
- Remove the lateral instrument panel trim on the front passenger's side (in case of ThermoCall, Golf VII).
- Remove the lower and lateral A-pillar trim on the front passenger's side (in case of ThermoCall, Golf VII).
- Remove the rear bench seat (in case of Golf VII).
- Remove the right rear seat (in case of Sportsvan).
- Open the right-hand tank-fitting service lid.



### Heater

- Remove years that do not apply from the type and duplicate label.
- Attach the duplicate label (type label) visibly in the appropriate place in the engine compartment.



## Preliminary Work for Passat

### Vehicle



- Open the fuel tank cap.
- Ventilate the fuel tank.
- Close the fuel tank cap again.
- Depressurise the cooling system.
- Disconnect and remove the battery completely together with the carrier.
- Remove the air filter completely, together with the intake hose.
- Remove the engine underride protection.
- Remove the right underride protection.
- Remove the fuel tank underride protection, if present.
- Remove the right front wheel.
- Remove the front right wheel well trim.
- Remove the storage compartment.
- Remove the lateral instrument panel trim on the driver's side.
- Remove the A-pillar trim on the driver's side (in case of Telestart).
- Remove the footwell trim on the front passenger's side.
- Remove the rear bench seat.
- Open the right-hand tank-fitting service lid.



### Heater

- Remove years that do not apply from the type and duplicate label.
- Attach the duplicate label (type label) visibly in the appropriate place in the engine compartment.



## Preliminary Work for Superb

### Vehicle

- Open the fuel tank cap.
- Ventilate the fuel tank.
- Close the fuel tank cap again.
- Depressurise the cooling system.
- Disconnect and remove the battery completely together with the carrier.
- Remove the air filter completely, together with the intake hose.
- Remove the engine underride protection.
- Remove the right underride protection.
- Remove the fuel tank underride protection, if present.
- Remove the right front wheel.
- Remove the front right wheel well trim.
- Remove the storage compartment.
- Remove the lateral instrument panel trim on the driver's side (in case of Telestart).
- Remove the A-pillar trim on the driver's side (in case of Telestart).
- Remove the lower A-pillar trim on the driver's side (in case of Telestart from MY 2016).
- Remove the footwell trim on the front passenger's side.
- Remove the rear bench seat.
- Open the right-hand tank-fitting service lid.



### Heater

- Remove years that do not apply from the type and duplicate label.
- Attach the duplicate label (type label) visibly in the appropriate place in the engine compartment.

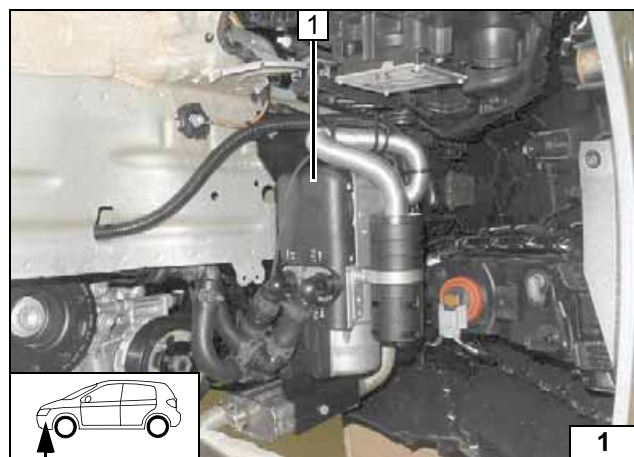

### Heater Assembly Installation Location

#### All vehicles

- 1 Heater assembly

Installation location

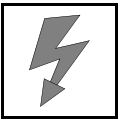

## Preparing Electrical System

- 1 Engine compartment fuse holder



### Installation Overview

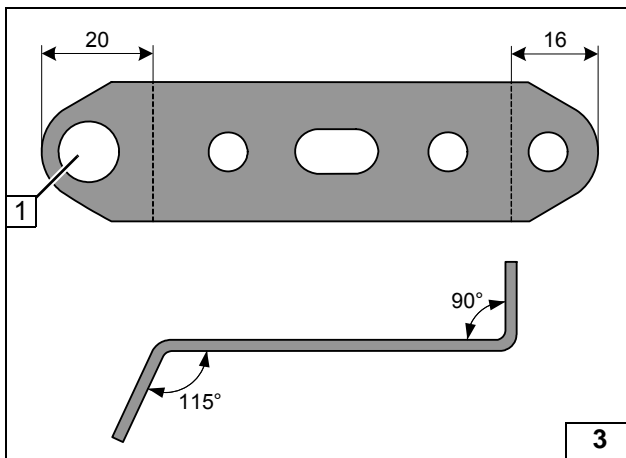
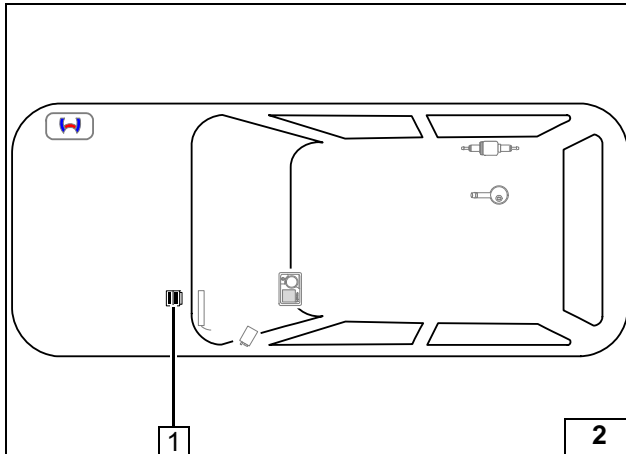

- 1 12.5 mm dia. hole

### Preparing perforated bracket

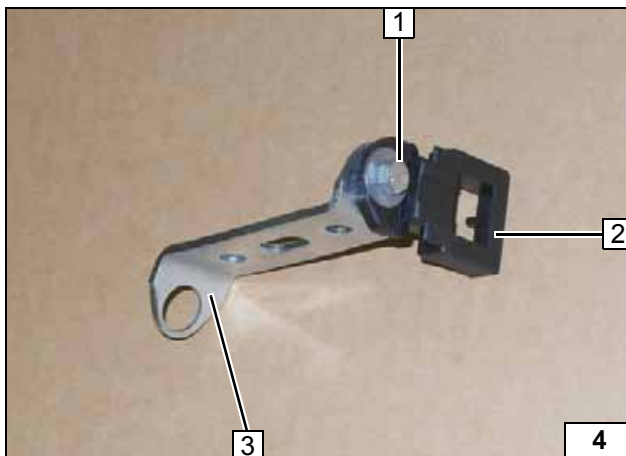

- 1 M5x16 bolt, washer [2x], nut
- 2 Fuse holder retaining plate
- 3 Perforated bracket

### Premounting engine compartment fuse holder

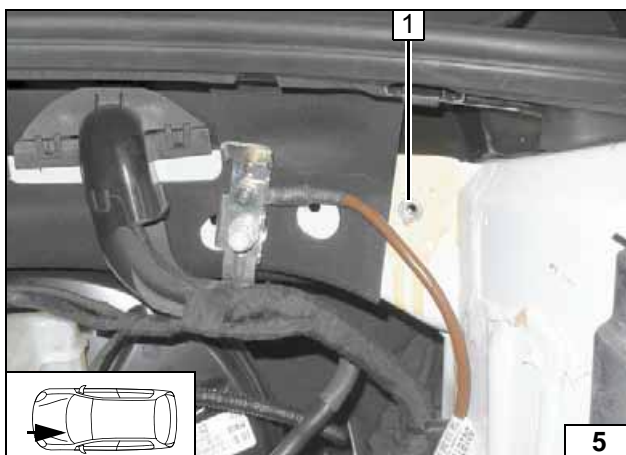

- 1 Drill out existing hole to 9.1 mm dia., rivet nut

### Installing rivet nut



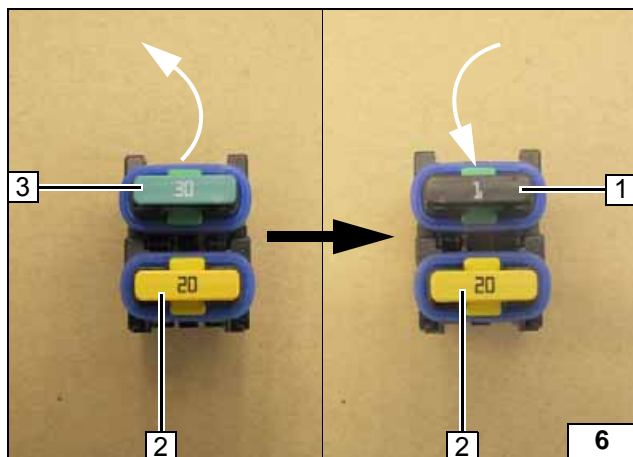

Replace passenger compartment 30A main fuse F2 **3** with 1A fuse **1**.

**2** 20A heater fuse F1

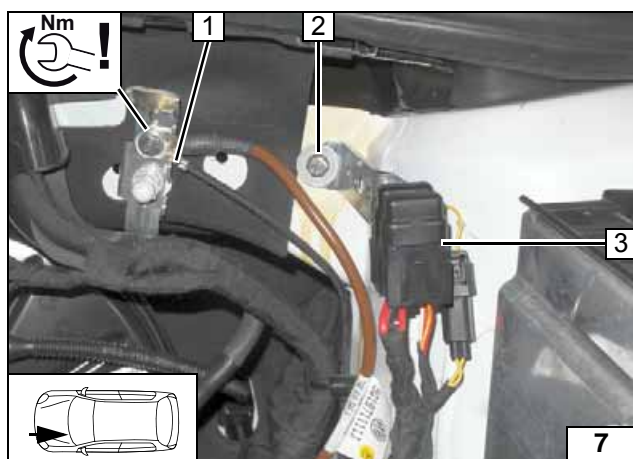

- 1** Earth wire on original vehicle earth point
- 2** M6x20 bolt, spring lockwasher, large diameter washer
- 3** Fuses F1-2

**Preparing engine compartment fuses**



**Installing engine compartment fuse holder**

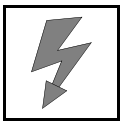

**Electrical System**



**Wiring Harness Routing**

Route heater wiring harness below the cover along the marking to the installation location of the heater and fasten using retaining clamp 1 [3x].

**Positive wire for Golf VII / Golf VII Sportsvan**

- 1 Positive wire on positive distributor
- 2 Wiring harnesses in original vehicle line duct

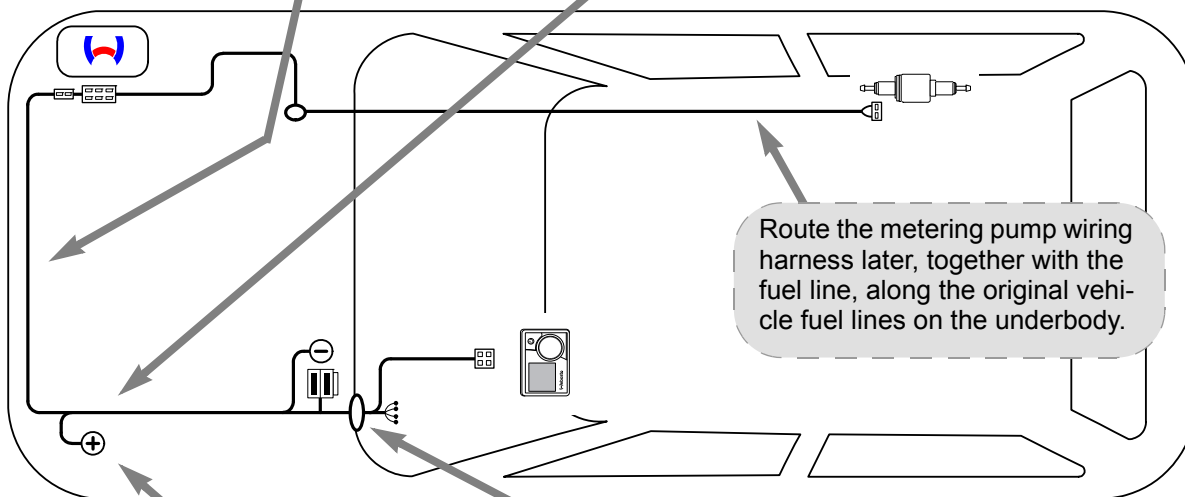
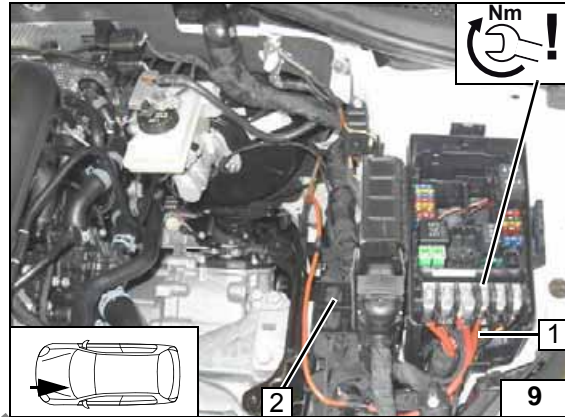
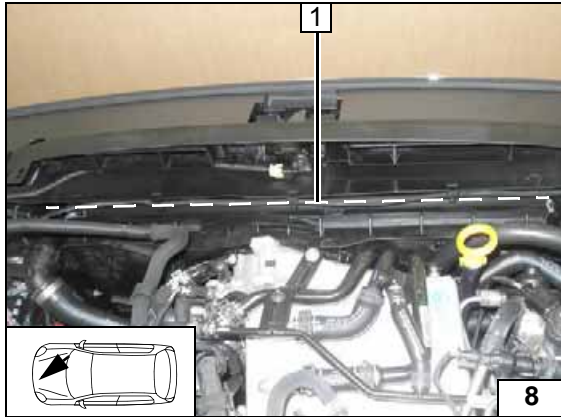

**Wiring harness routing diagram**

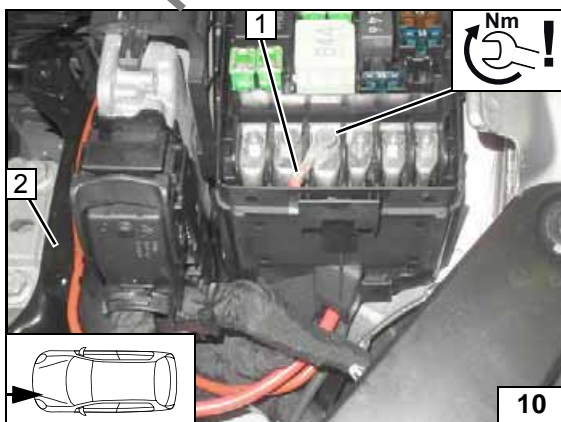

**Positive wire for Passat / Superb**

- 1 Positive wire on positive distributor
- 2 Wiring harnesses in original vehicle line duct

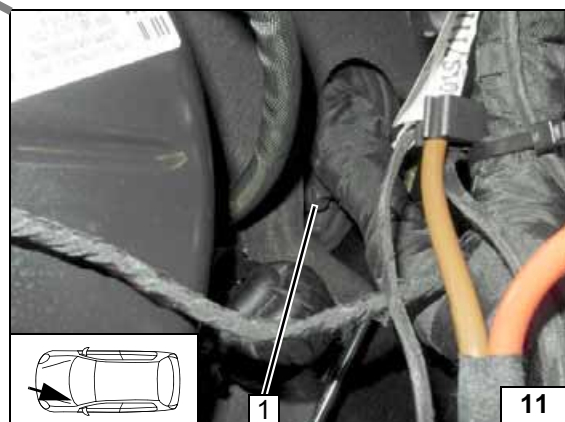

**Wiring harness pass through**

Route heater wiring harnesses and heater control through protective rubber plug 1 to the passenger compartment.



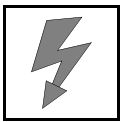

## Air-Conditioning Control

**!** Integrate the A/C control as explained in the separate installation documentation:

Installation documentation '**Webasto Standard**' A/C control for VW / Skoda / Seat with AC and AAC  
or

Installation documentation '**Webasto Comfort**' A/C control for VW / Skoda / Seat with AAC

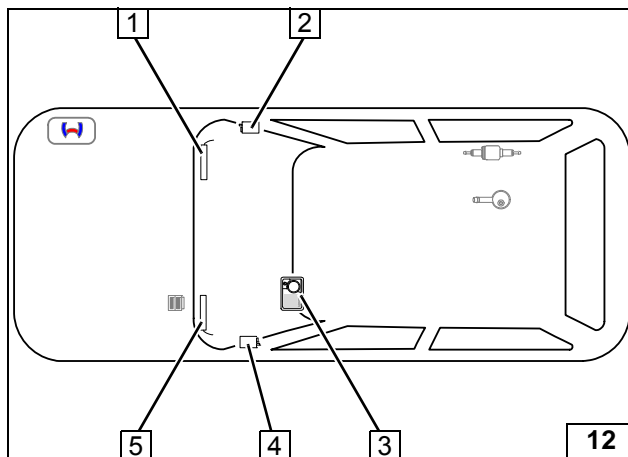

## Heater Control Elements for Golf VII

- 1 ThermoCall aerial
- 2 ThermoCall
- 3 MultiControl CAR
- 4 Telestart receiver
- 5 Telestart aerial

### Installation Overview

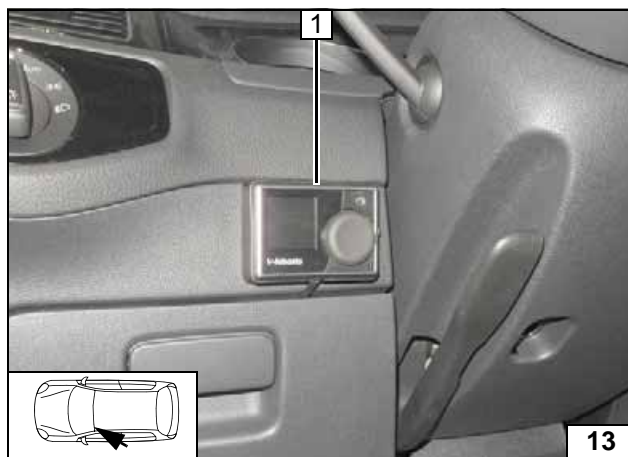

## MultiControl CAR Option

- 1 Installation frame



### Installing MultiControl CAR

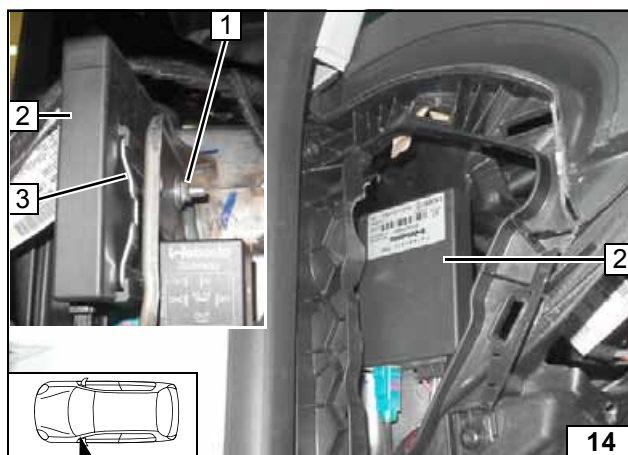

## Remote Option (Telestart)

- 1 M5x16 bolt, large diameter washer, nut, existing hole
- 2 Receiver
- 3 Bracket of receiver



### Installing receiver

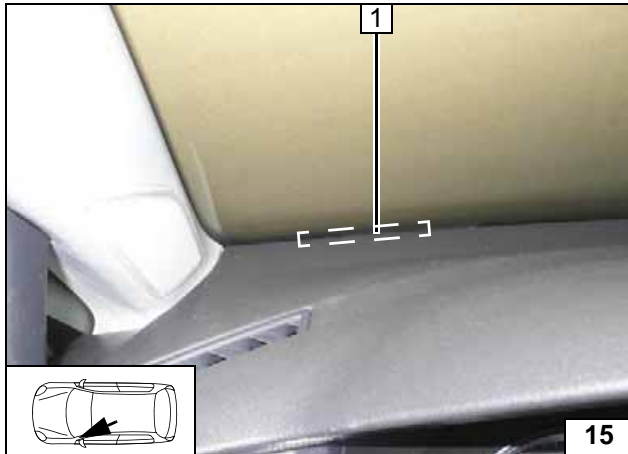
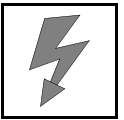

1 Aerial

Installing aerial

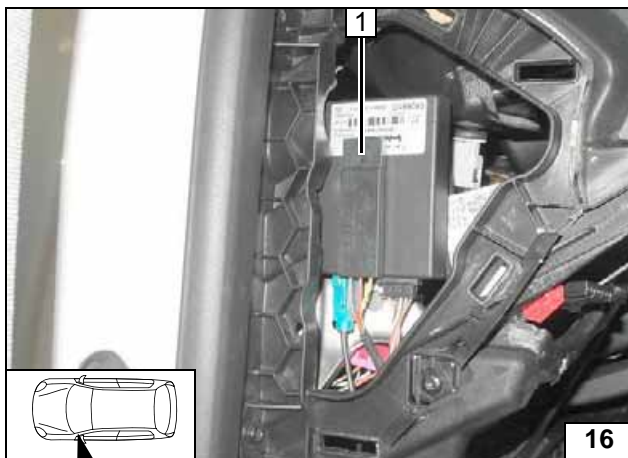

Temperature sensor T100 HTM

Fasten temperature sensor 1 with double-sided adhesive tape.



Installing temperature sensor



ThermoCall Option

Fasten receiver 1 with double-sided adhesive tape.



Installing receiver

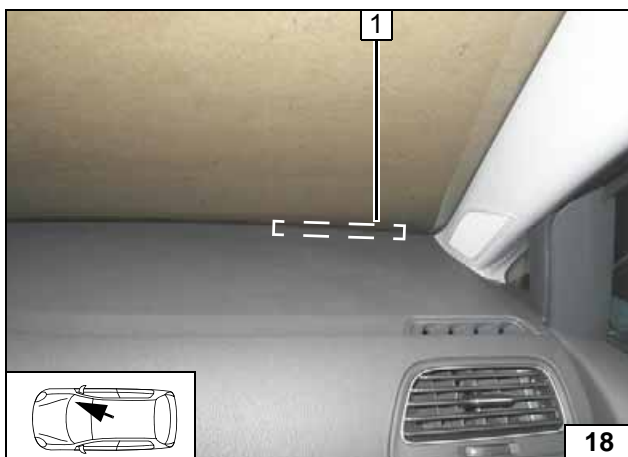

1 Aerial (optional)

Installing aerial

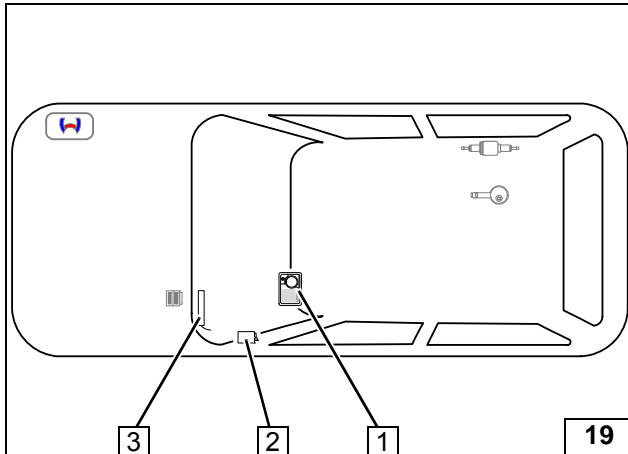
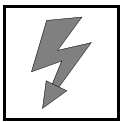

### Heater Control Elements for Sportsvan

- 1 MultiControl CAR
- 2 Telestart / ThermoCall receiver
- 3 Telestart / ThermoCall aerial



### Installation Overview

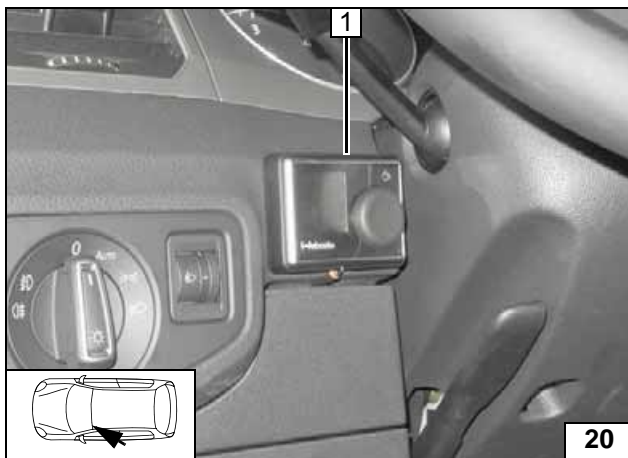

### MultiControl CAR Option

- 1 Installation frame



### Installing MultiControl CAR

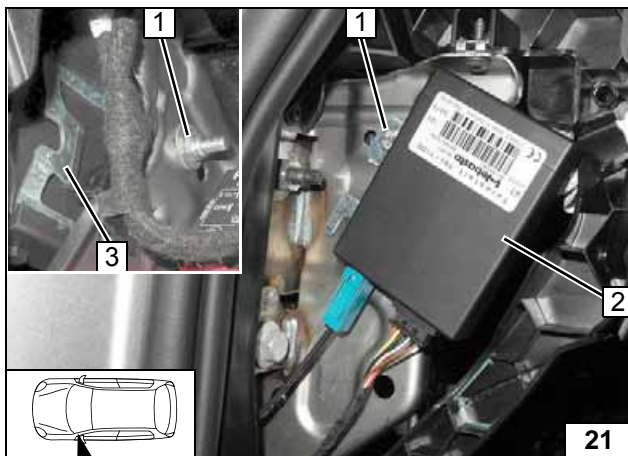

### Remote Option (Telestart)

- 1 M5x16 bolt, large diameter washer, nut, existing hole
- 2 Receiver
- 3 Bracket of receiver



### Installing receiver

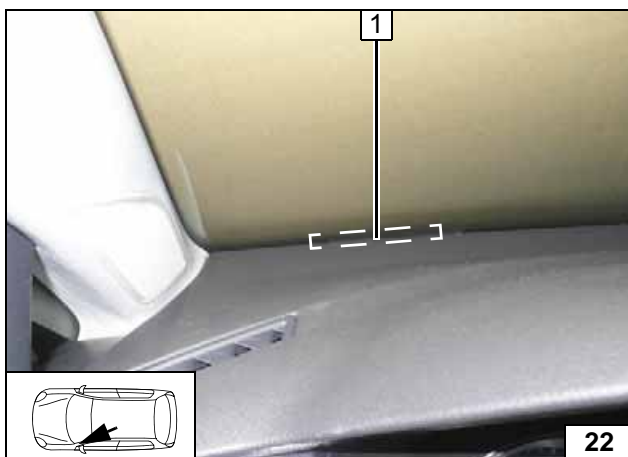

- 1 Aerial

### Installing aerial



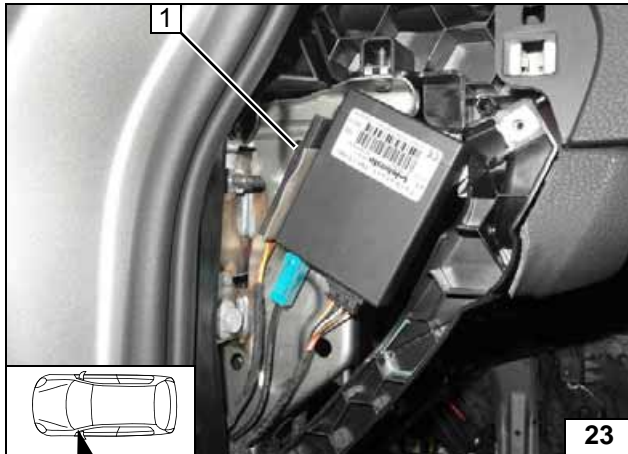
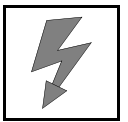

**Temperature sensor T100 HTM**

Fasten temperature sensor 1 with double-sided adhesive tape.



**Installing temperature sensor**

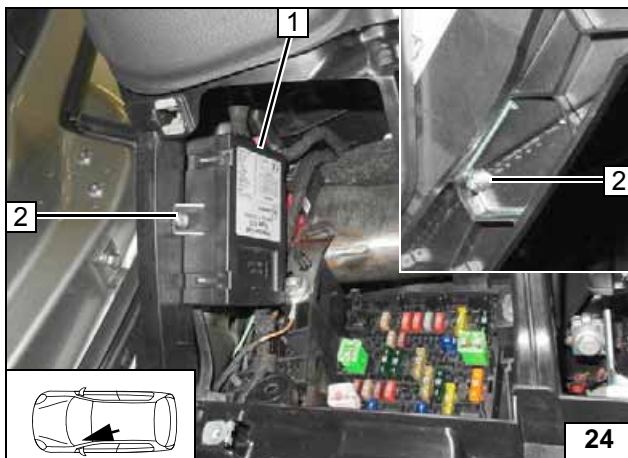

**ThermoCall Option**

- 1 Receiver
- 2 2.5 mm dia. hole, 5.5x9.5 mm self-tapping screw



**Installing receiver**

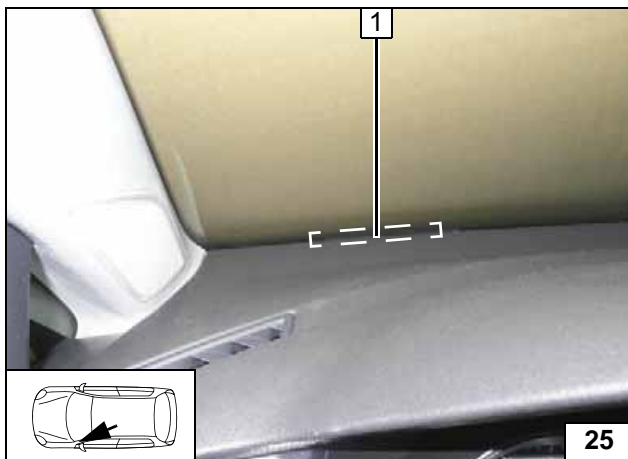

- 1 Aerial

**Installing aerial**

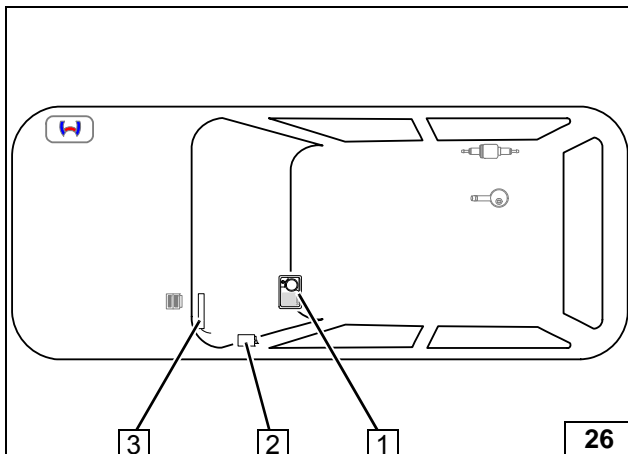

**Passat / Superb Heater Controls**

- 1 MultiControl CAR
- 2 Telestart / ThermoCall receiver
- 3 Telestart / ThermoCall aerial



**Installation Overview**

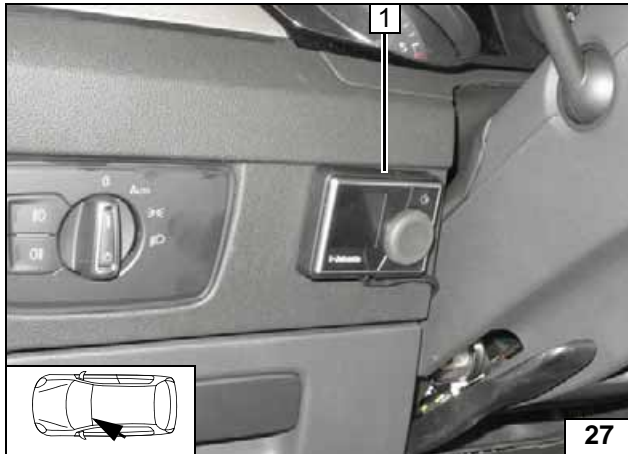
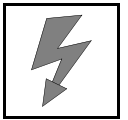

**MultiControl CAR Option**

**Passat**

- 1 Installation frame



**Installing MultiControl CAR**

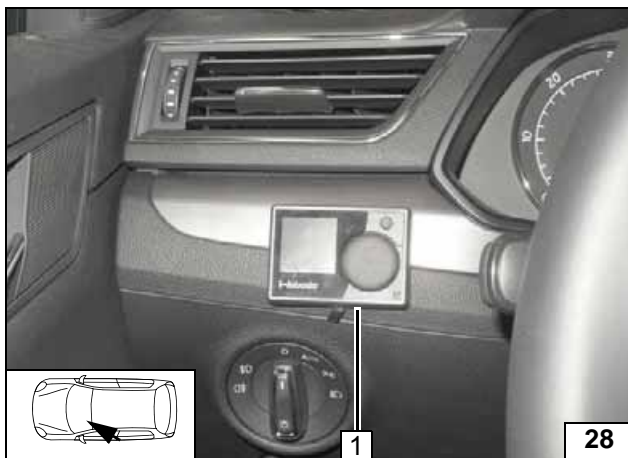

**MultiControl CAR Option**

**Superb**

- 1 Installation frame



**Installing Multi-Control CAR**

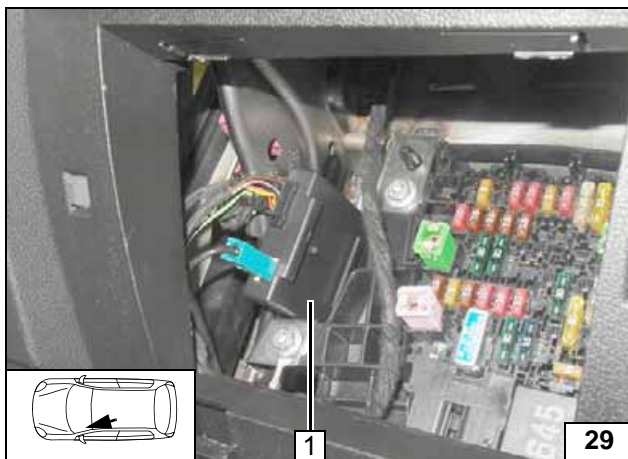

**Remote Option (Telestart)**

**Passat / Superb**

Fasten receiver 1 with double-sided adhesive tape.



**Installing receiver**

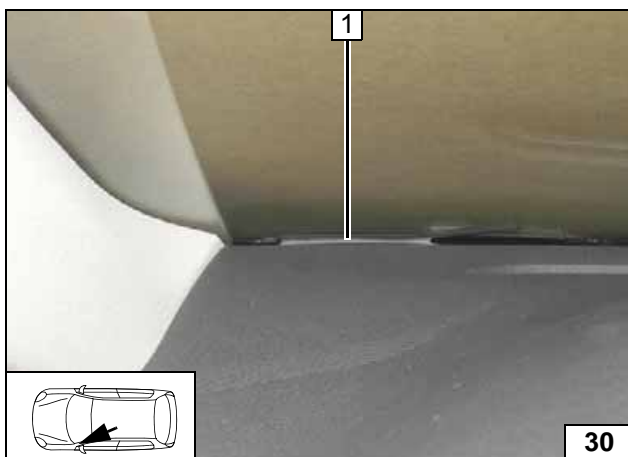

- 1 Aerial

**Installing aerial**

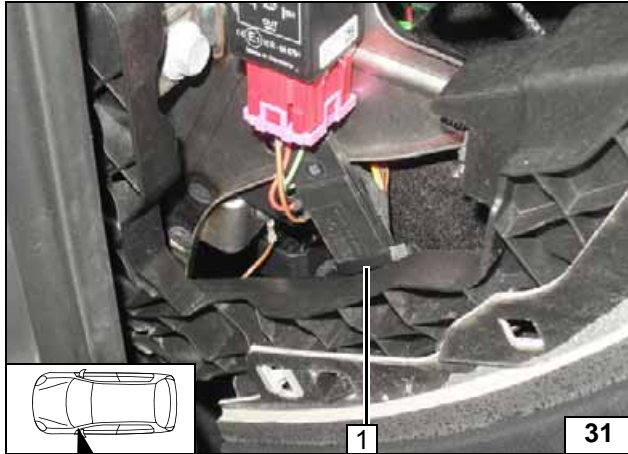
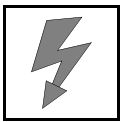

**Temperature sensor T100 HTM**

Fasten temperature sensor 1 with cable tie.



**Installing temperature sensor**

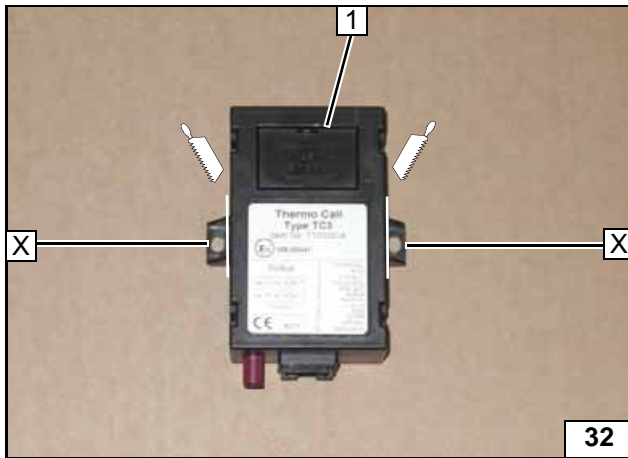

**ThermoCall Option**

**Passat / Superb**

1 Receiver

X =



**Removing lugs**

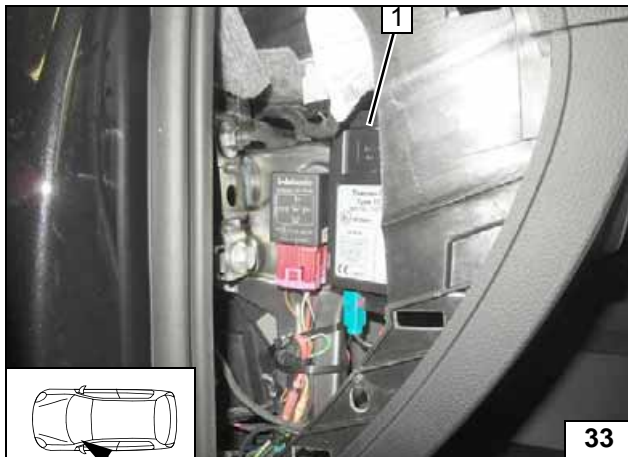

Fasten receiver 1 with double-sided adhesive tape.



**Installing receiver**

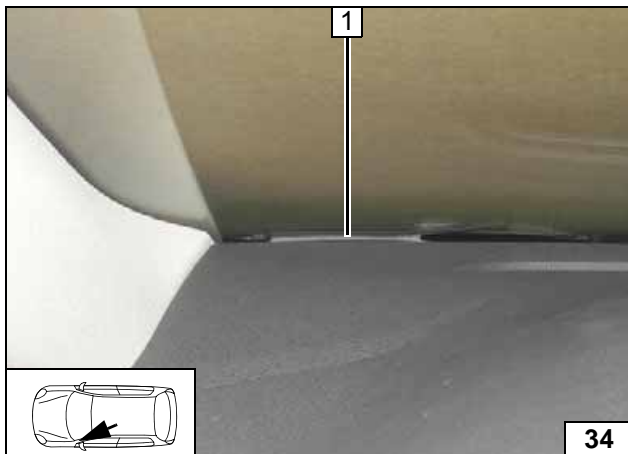

1 Aerial (optional)

**Installing aerial**



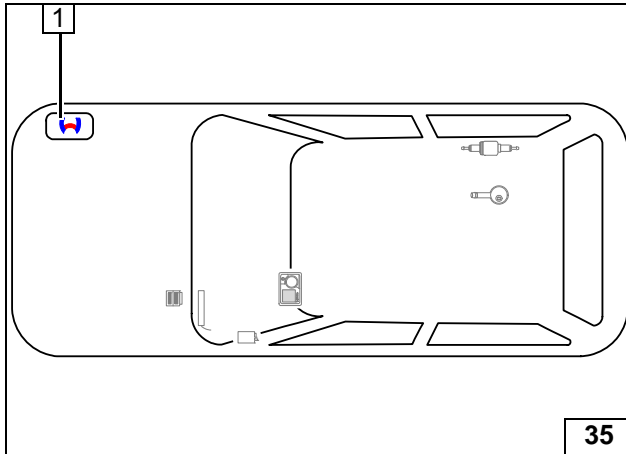
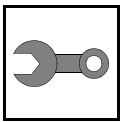

### Preparing Installation Location

1 Heater assembly



Installation Overview

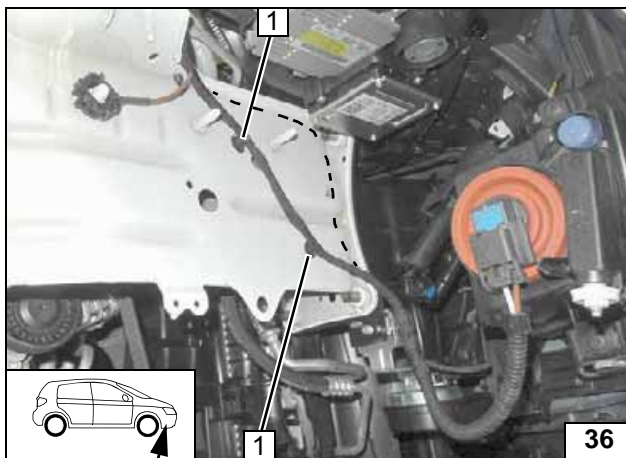

### Golf VII / Golf VII Sportsvan

Detach retaining clip 1 [2x] from original vehicle wiring harness. Route wiring harness along the marking (dotted line).



Aligning wiring harness

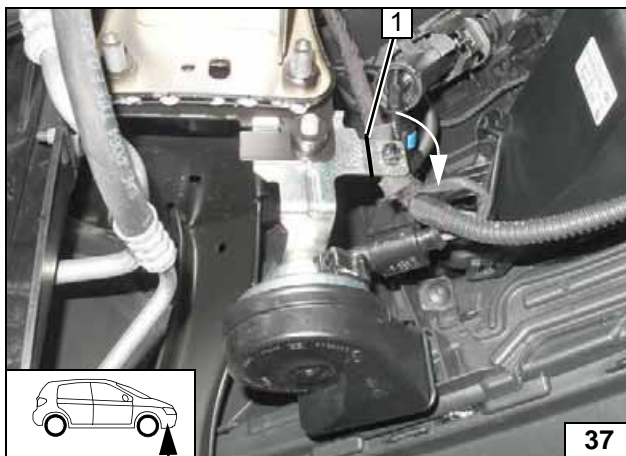

Angle down horn bracket at marking 1 by 90°.



Aligning horn bracket



### Passat / Superb

Detach retaining clip 1 with original vehicle wiring harness.



Aligning wiring harness

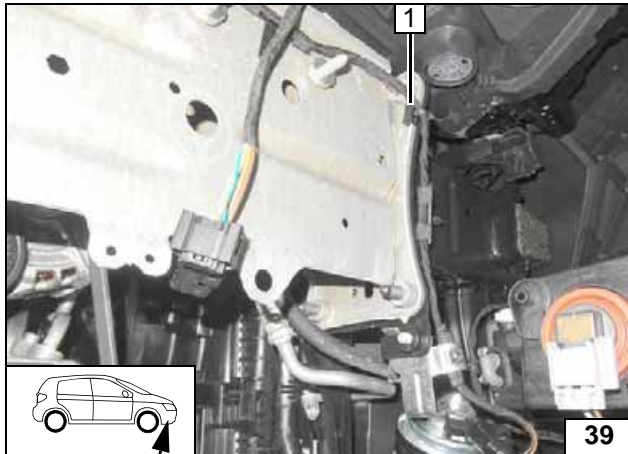
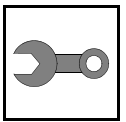

1 Edge clip cable tie

Fastening wiring harness

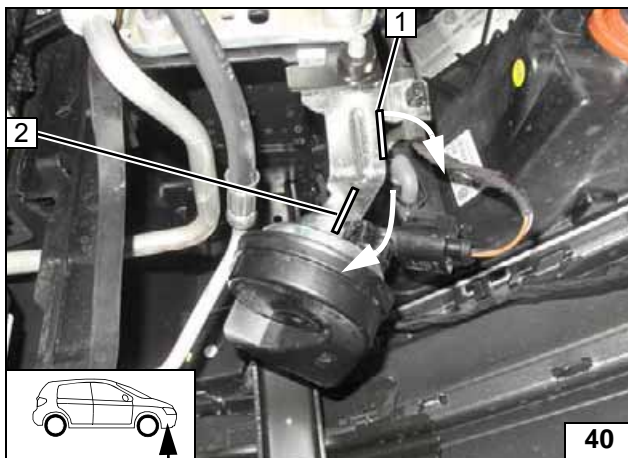

**Passat**

Angle down horn bracket at marking 1 by 90°. Twist horn bracket at marking 2 by 20°.



Aligning horn bracket

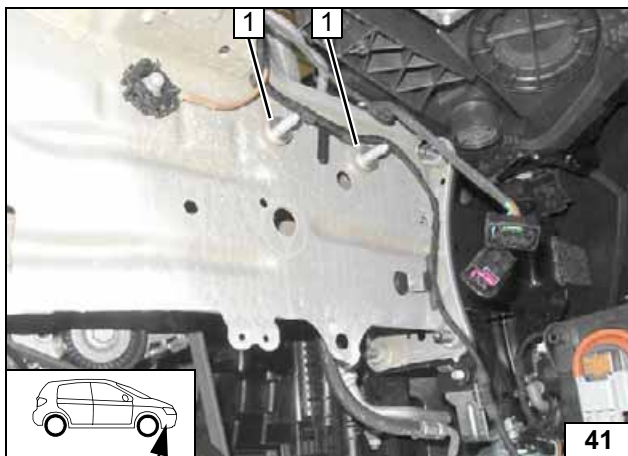

**All vehicles**

- 1 5mm spacer on original vehicle stud bolt [2x]

Aligning wiring harness

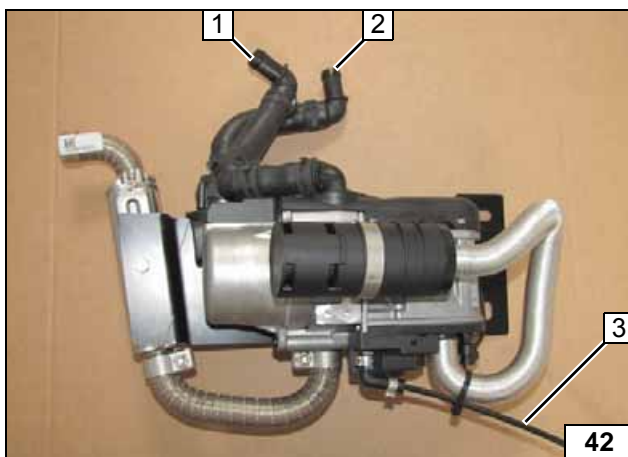

**Installing Heater Assembly**

- 1 Connect heater outlet
- 2 Connect heater inlet
- 3 Fuel line

Heater assembly

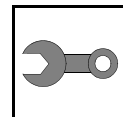

- 1 Heater wiring harness connector [2x]

Installing wiring harness

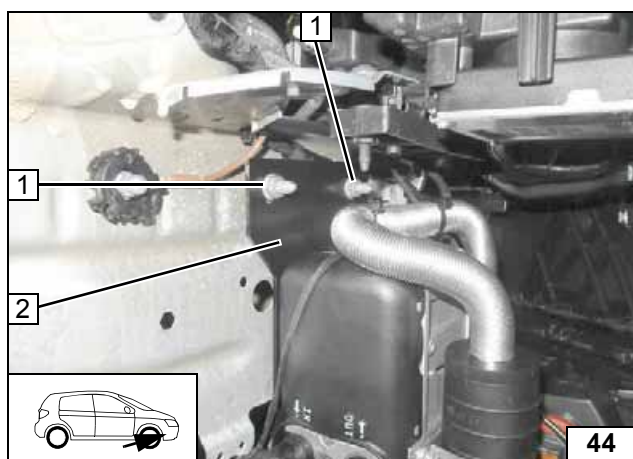

- 1 Original vehicle stud bolt, M8 flanged nut [2x each]
- 2 Bracket

Installing heater

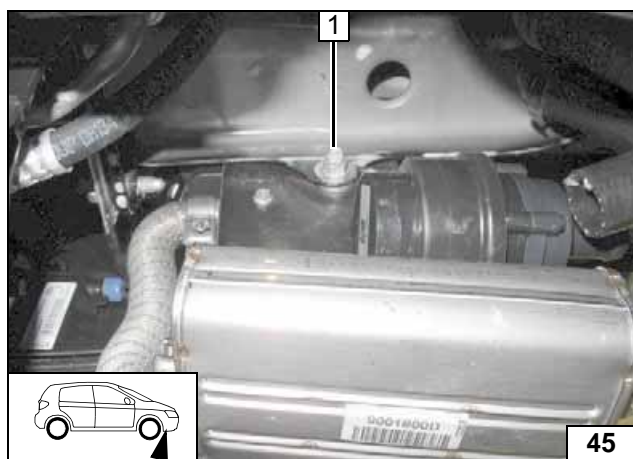

- 1 Stud bolt of bracket, large diameter washer, M8 flanged nut

Installing heater

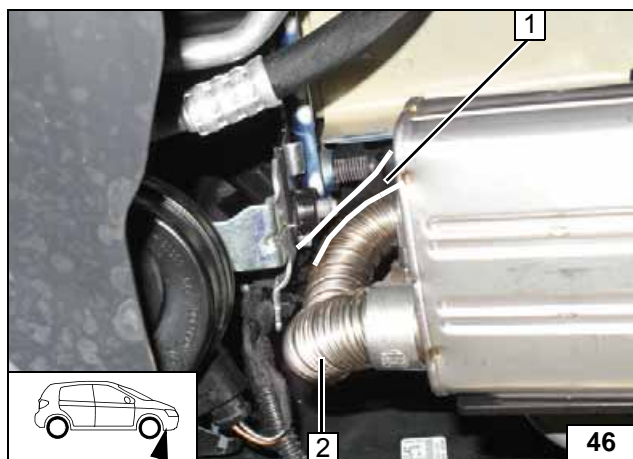

Ensure sufficient distance between exhaust pipe 2 and bolts of horn bracket at position 1, correct if necessary.



Aligning exhaust pipe

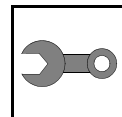

Ensure sufficient distance from neighbouring vehicle components, correct if necessary.

  $\geq 10 \text{ mm}$



**Checking distances**





**Fuel**



Open the vehicle's fuel tank cap, ventilate the tank and then re-close the tank lock.

Catch any fuel running off in an appropriate container.



Route fuel line and metering pump wiring harness so that they are protected against stone impact. Unless specified otherwise, always fasten using cable ties.

Provide rub protection for fuel line and wiring harness in areas where there are sharp edges.

The fuel line and wiring harness are routed to the metering pump as shown in the wiring harness routing diagram.

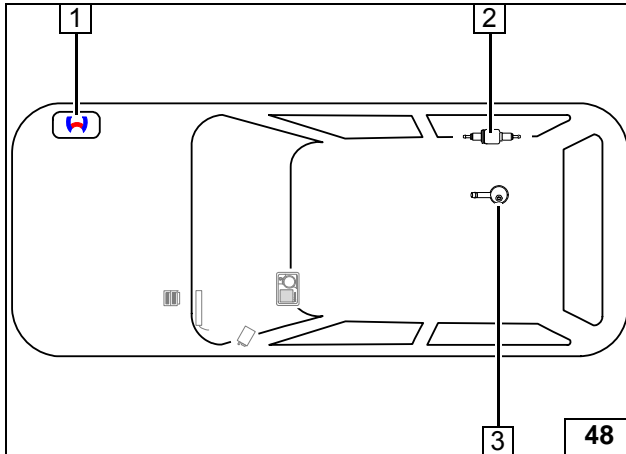

- 1 Heater assembly
- 2 Metering pump
- 3 FuelFix

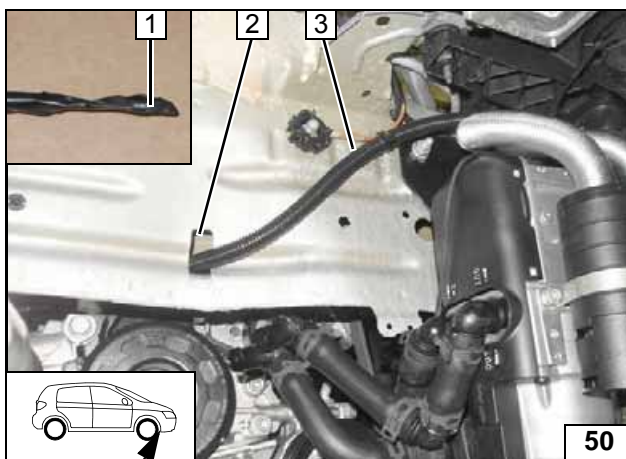
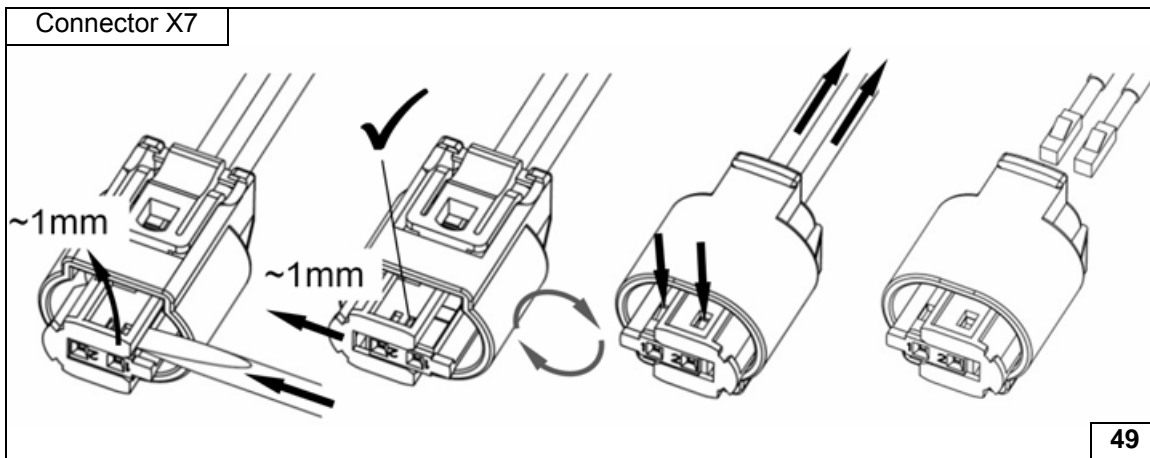

Close the opening of the fuel line 1 with insulating tape.

Pull fuel line and metering pump wiring harness into 10 mm dia. corrugated tube 2 and route to the underbody through original vehicle pass through 2.



**Installation Overview**

**Dismantling metering pump connector**



**Routing lines**

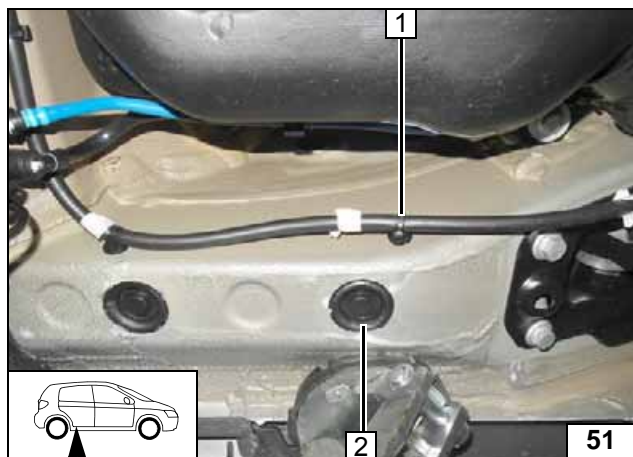

- 1 Detach retaining clip from hole (if present)
- 2 Remove cover cap (will be remounted later)

Preparing installation location of metering pump

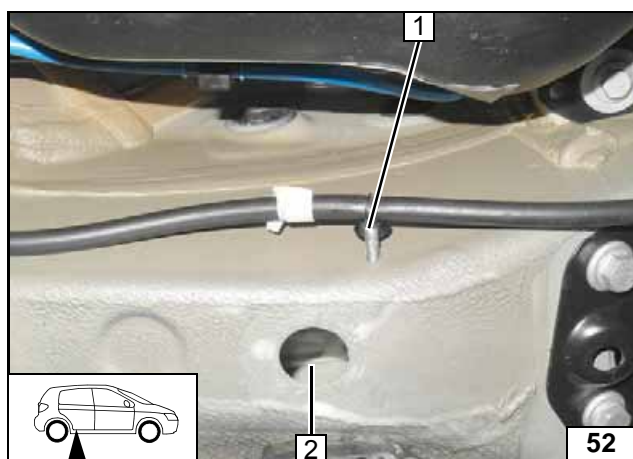

Insert M6x20 bolt 1 through opening 2 into hole.



Preparing installation location of metering pump

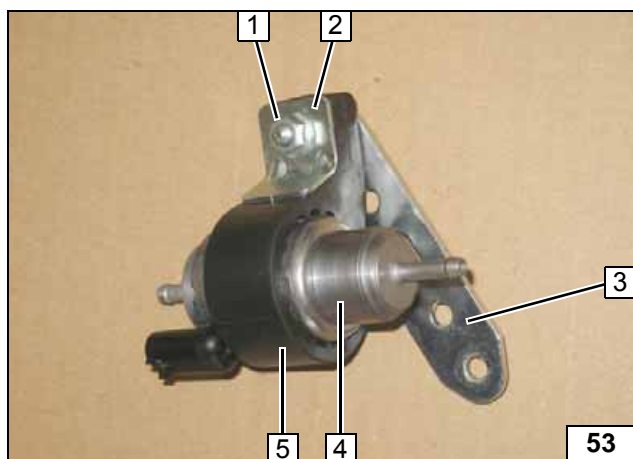

- 1 M6x25 bolt, flanged nut
- 2 Support angle bracket
- 3 Perforated bracket
- 4 Metering pump
- 5 Metering pump mount

Premounting metering pump

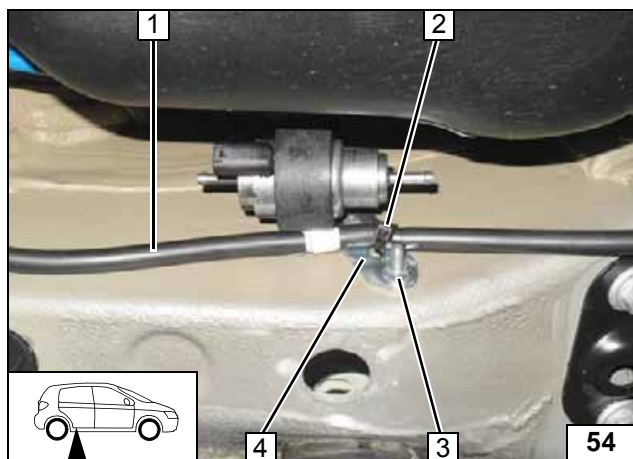

Fasten original vehicle wiring harness 1 with cable tie 2 on perforated bracket 4.

- 3 M6 flanged nut



Installing metering pump

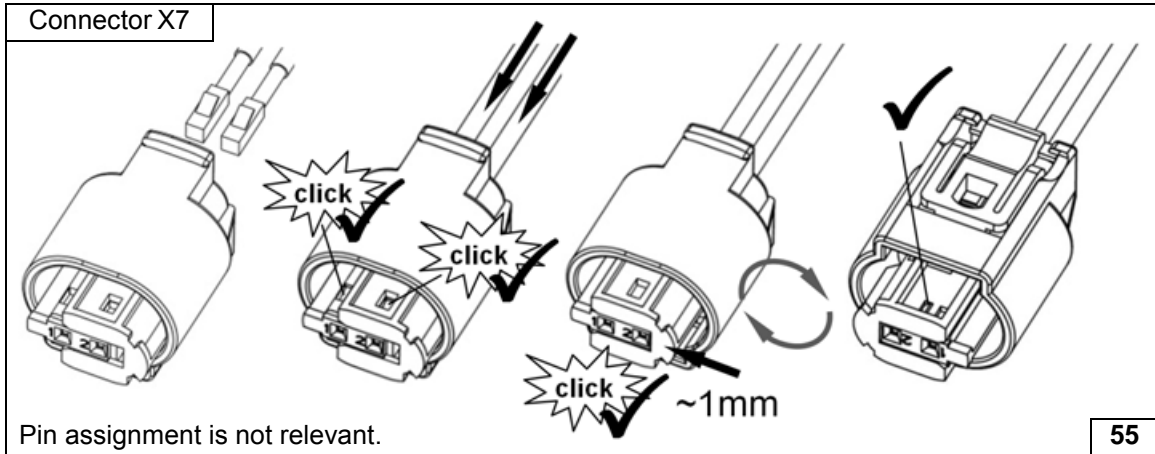
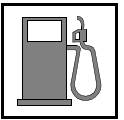

Pin assignment is not relevant.

55

Completing metering pump connector

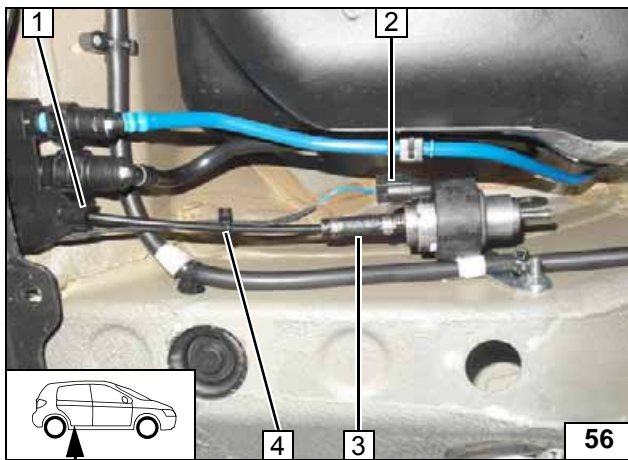

- 1 Original vehicle pass through
- 2 Metering pump wiring harness, connector X7 mounted
- 3 Fuel line of heater, hose section, 10 mm dia. clamp [2x]
- 4 Cable tie



Connecting metering pump

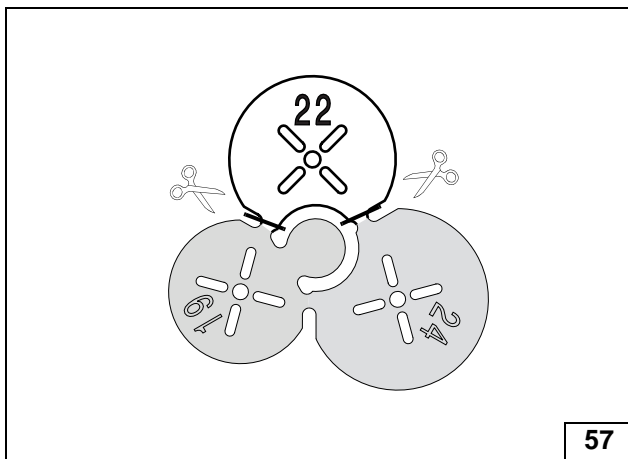

### FuelFix Installation for TSI

Preparing drilling template

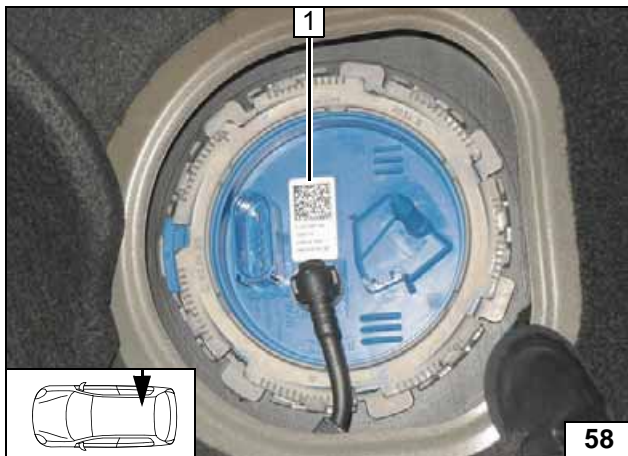

Work step F1.

Remove sticker 1, will finally be fixed on again in a new position.



Moving sticker



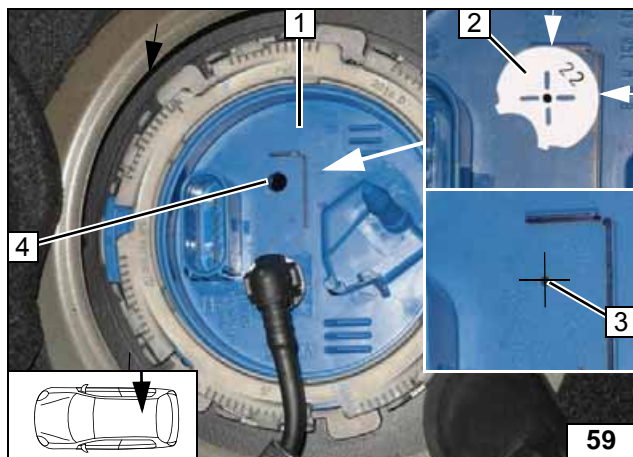

Work steps F2 and F3.

- 1 Fuel tank sending unit
- 2 Position template with outer dia.  $d_a = 22\text{mm}$  at the markings.
- 3 Hole pattern
- 4 Hole made with provided drill



Copying hole pattern, drilling hole

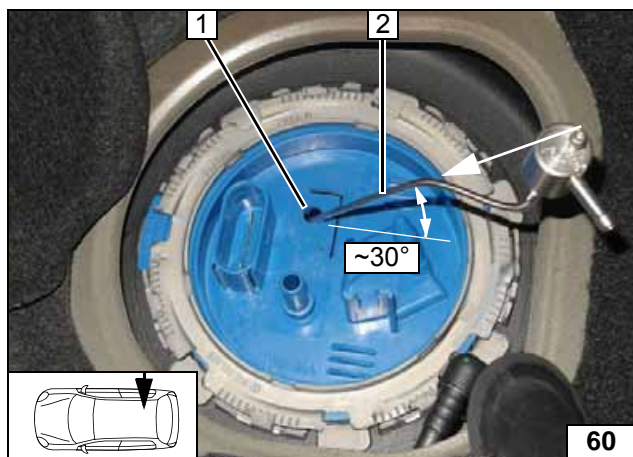

Work steps F4 and F5.

Bend FuelFix 2 according to template and cut to length. Insert into hole 1.



Inserting FuelFix

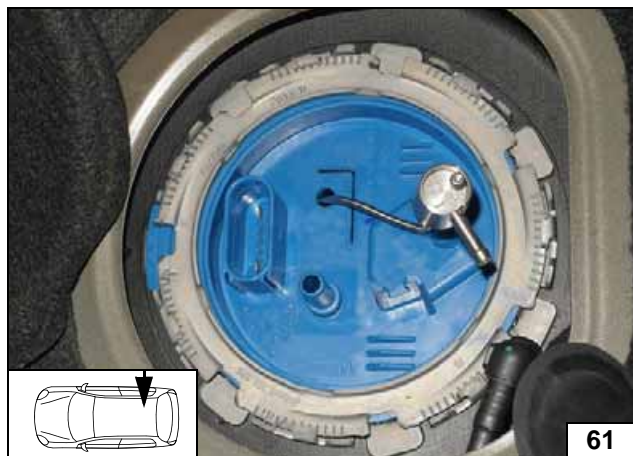

Work step F5.

Inserting FuelFix



Inserting FuelFix



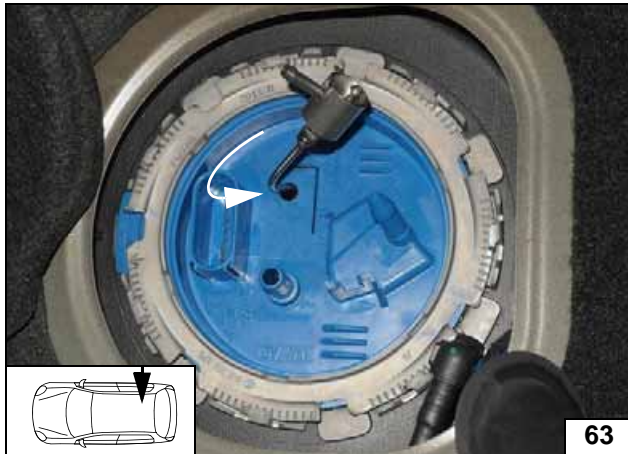

Inserting FuelFix

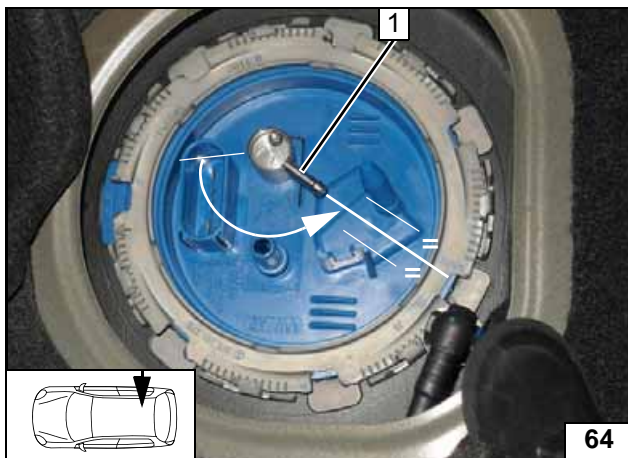

Work steps F5.3 and F5.4.

Align FuelFix 1 as shown.



Inserting FuelFix

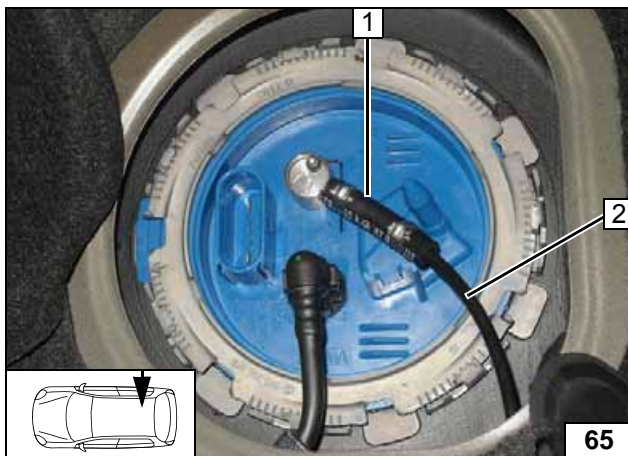

Work step F6.

- 1 Hose section, 10mm dia. clamp [2x]
- 2 Fuel line

Connect-  
ing fuel line

Work step F7.

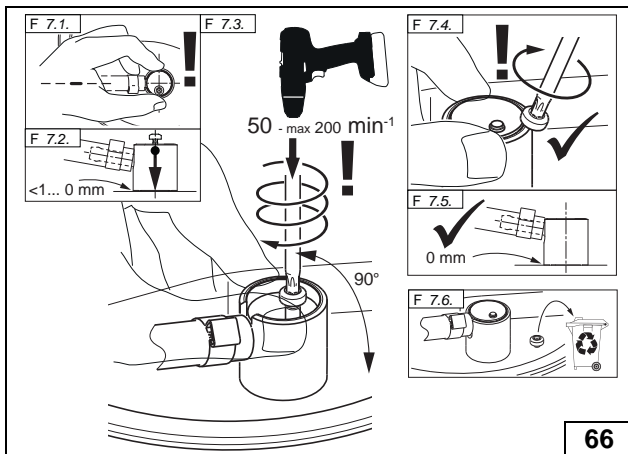

Installing FuelFix





Work step F8.

Ensuring firm seating of FuelFix

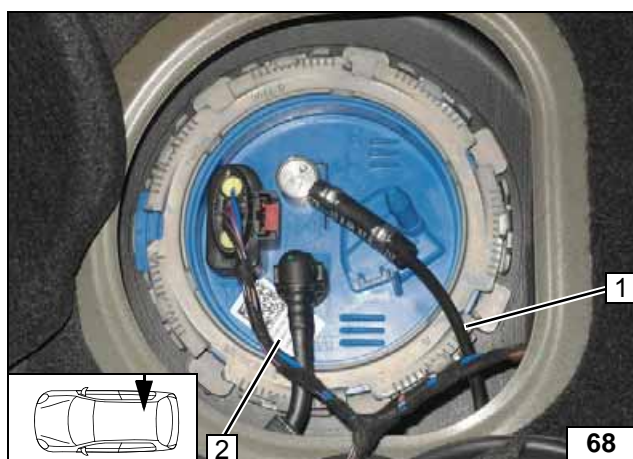

Attach fuel line 2 for tension relief at an appropriate point.



- 1 Fuel line
- 2 Moving sticker

Securing fuel line

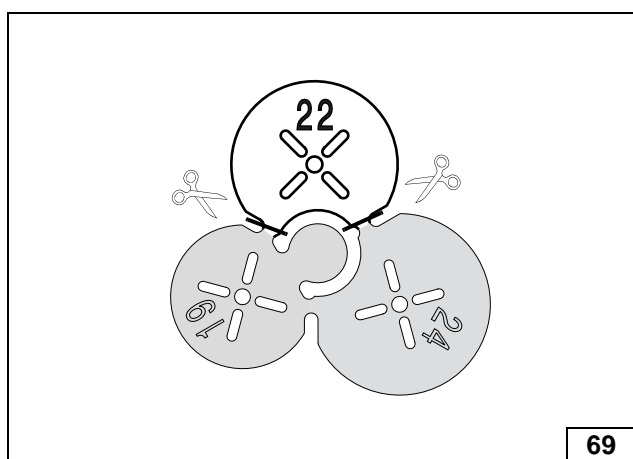

### Installing FuelFix for Golf VII / Golf VII Sportsvan TDI

Preparing drilling template

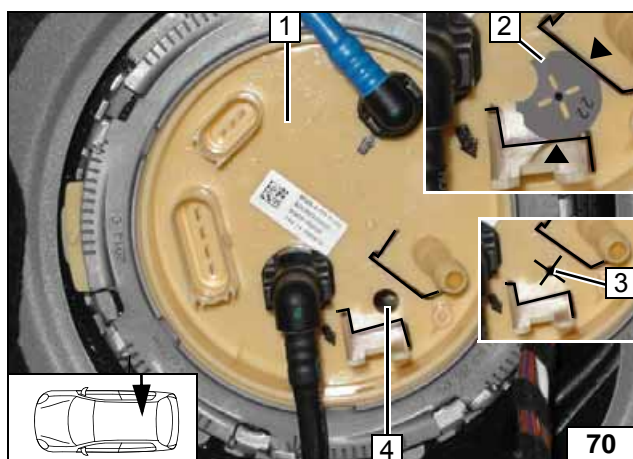

Work steps F1, F2 and F3.

- 1 Fuel tank sending unit
- 2 Position template with outer dia.  $d_a = 22\text{mm}$  at the markings.
- 3 Hole pattern
- 4 Hole made with provided drill



Copying hole pattern, drilling hole

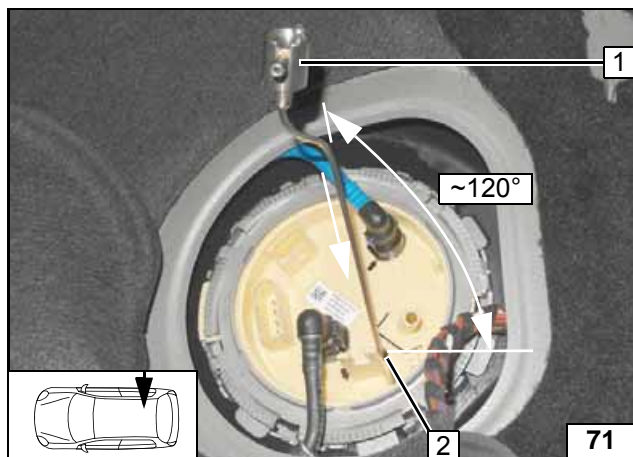

Work steps F4 and F5.

Bend FuelFix 1 according to template and cut to length. Insert into hole 2.



**Inserting FuelFix**



Work step F5.

**Inserting FuelFix**

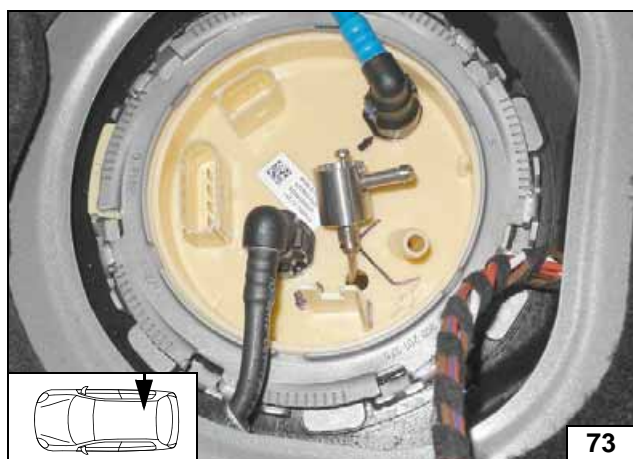

**Inserting FuelFix**

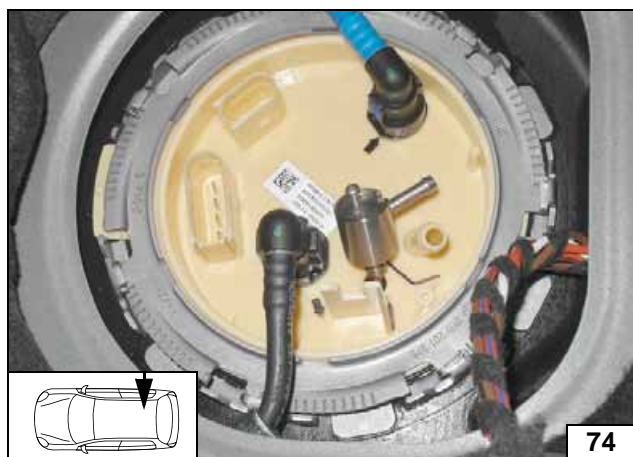

**Inserting FuelFix**



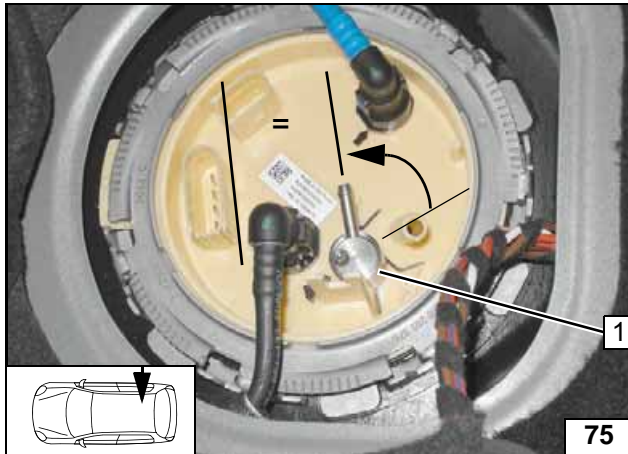

Work steps F5.3 and F5.4.

Align FuelFix 1 as shown.



Inserting FuelFix

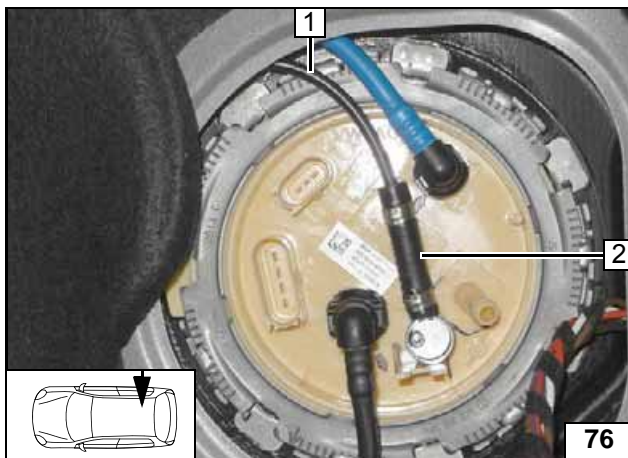

Work step F6.

- 1 Fuel line
- 2 Hose section, 10mm dia. clamp [2x]

Connecting fuel line

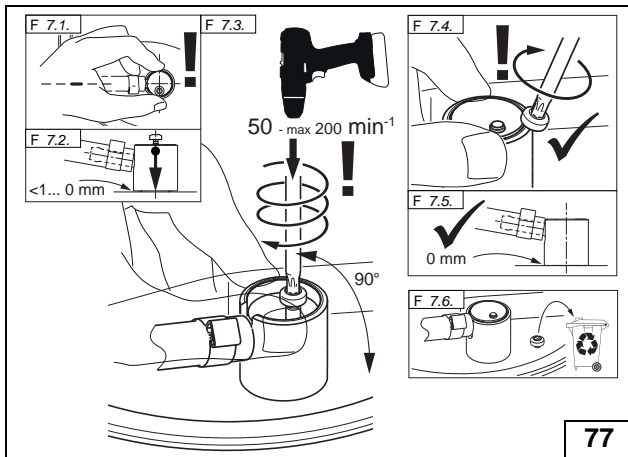

Work step F7.



Installing FuelFix

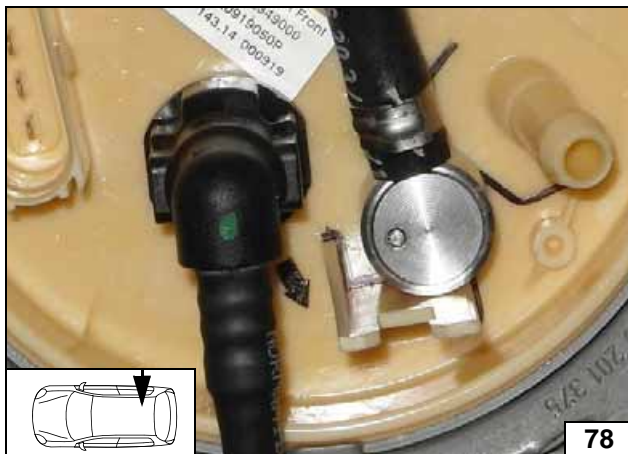

Work step F8.

Ensuring firm seating of FuelFix

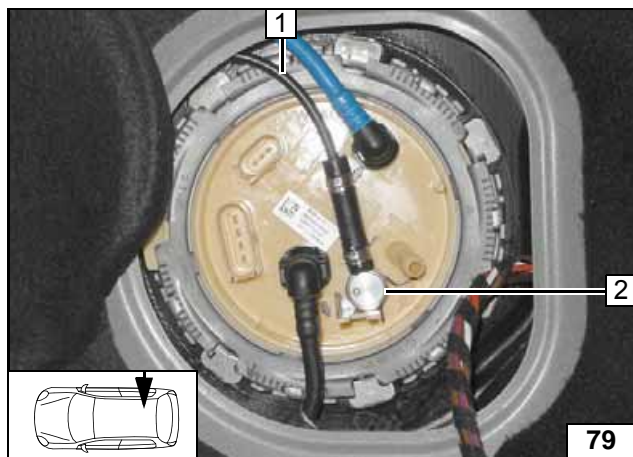

Attach fuel line 1 for tension relief at an appropriate point.



- 1 Fuel line
- 2 FuellFix installed

**Securing fuel line**

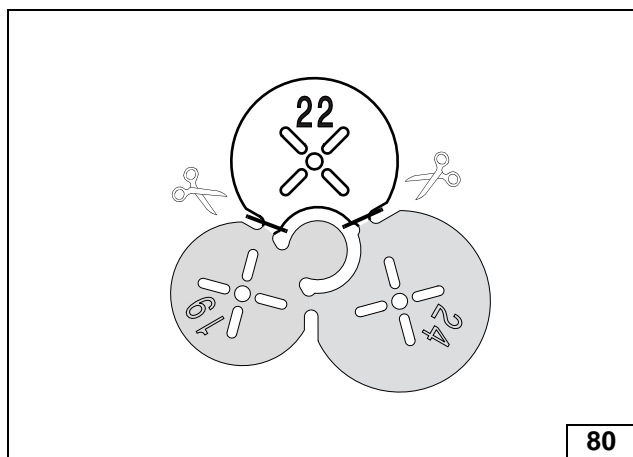

**Installing FuellFix for Passat / Superb TDI Front-Wheel Drive**

**Preparing drilling template**

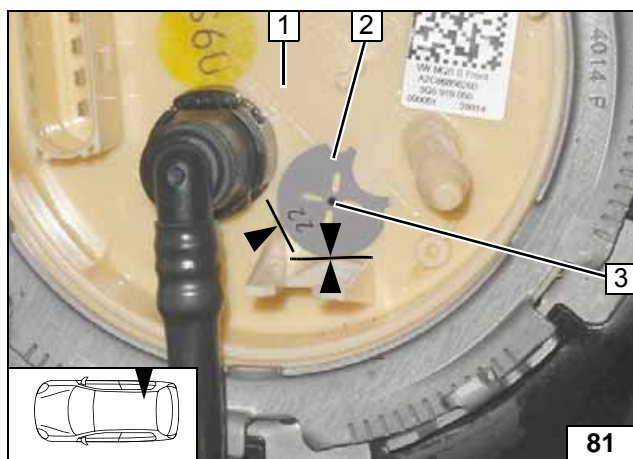

Work steps F1 and F2.



- 1 Fuel tank sending unit
- 2 Position template with outer dia.  $d_a = 22\text{mm}$  at the markings.
- 3 Hole pattern

**Copying hole pattern**

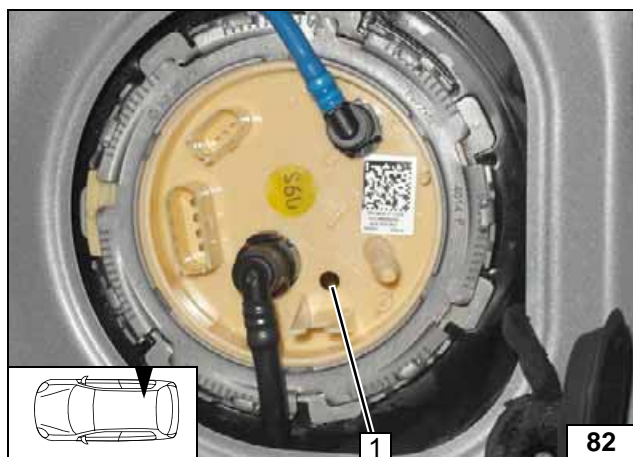

Work step F3.

- 1 Hole made with provided drill

**Hole for FuellFix**

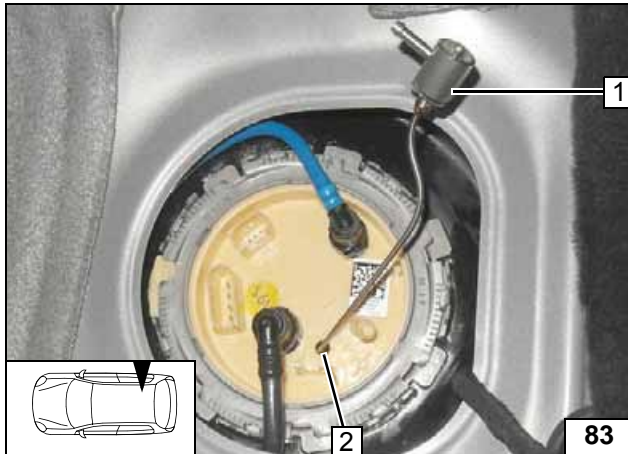
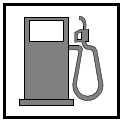

Work steps F4 and F5.

Bend FuelFix 1 according to template and cut to length. Insert into hole 2.



**Inserting FuelFix**

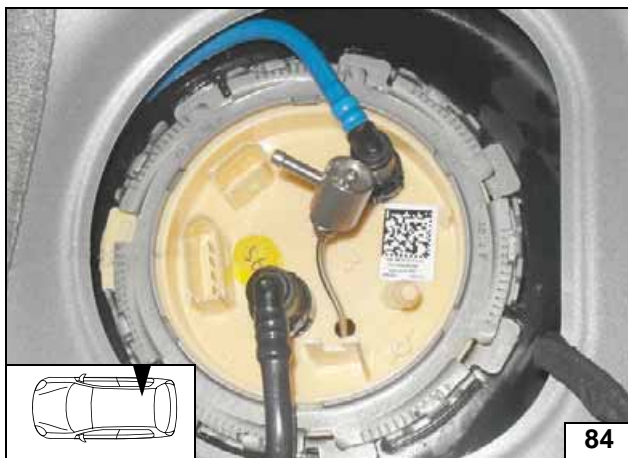

Work step F5.

**Inserting FuelFix**

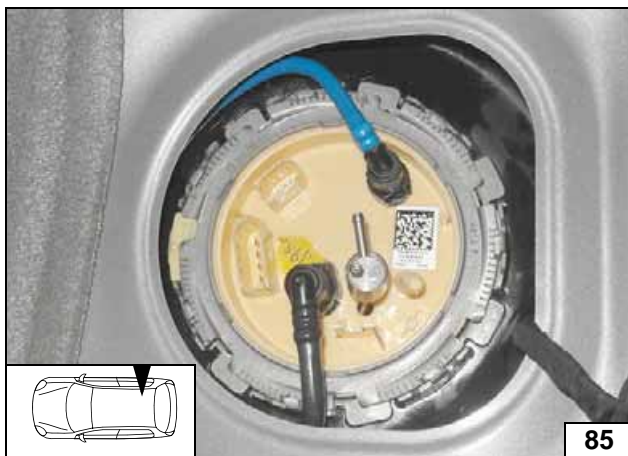

**Inserting FuelFix**

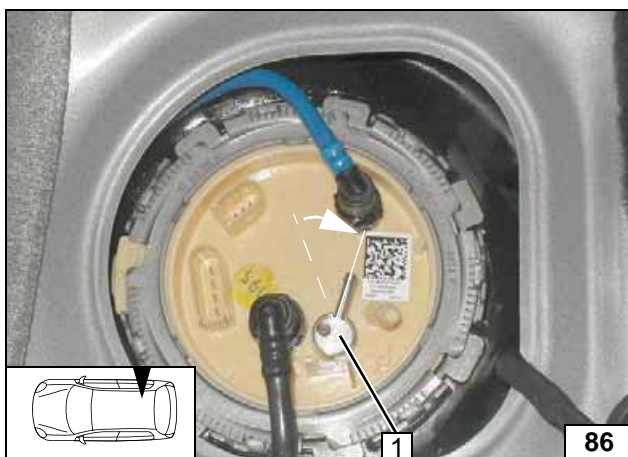

Work steps F5.3 and F5.4.

Align FuelFix 1 as shown.



**Aligning FuelFix**



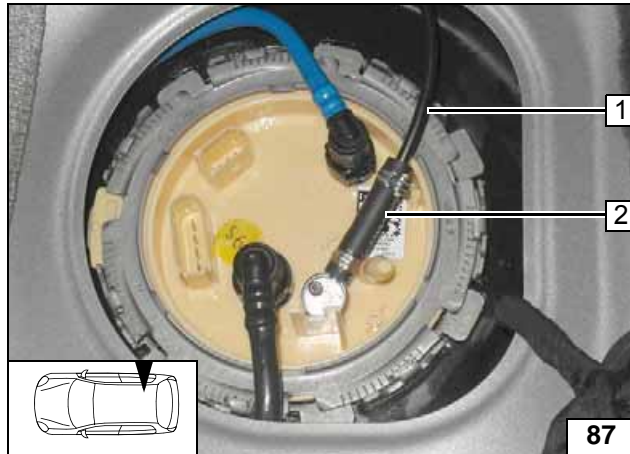

Work step F6.

- 1 Fuel line
- 2 Hose section, 10mm dia. clamp [2x]

Connect-  
ing fuel line

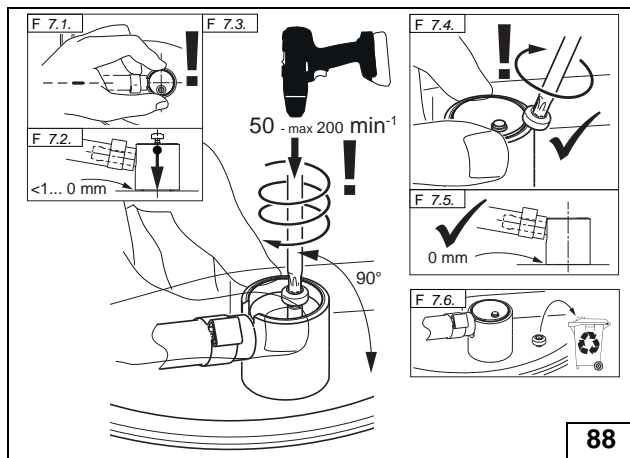

Work step F7.



Installing  
FuelFix



Work step F8.

Ensuring  
firm seating  
of FuelFix

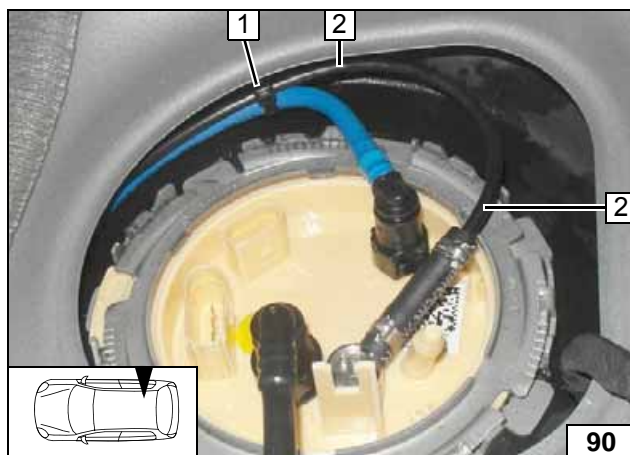

- 1 Cable tie as tension relief
- 2 Fuel line

Securing fuel  
line

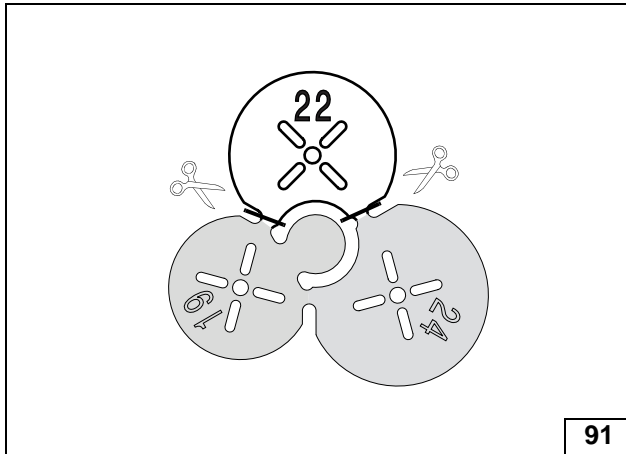

### Installing FuelFix for Superb TDI 4x4

Preparing drilling template

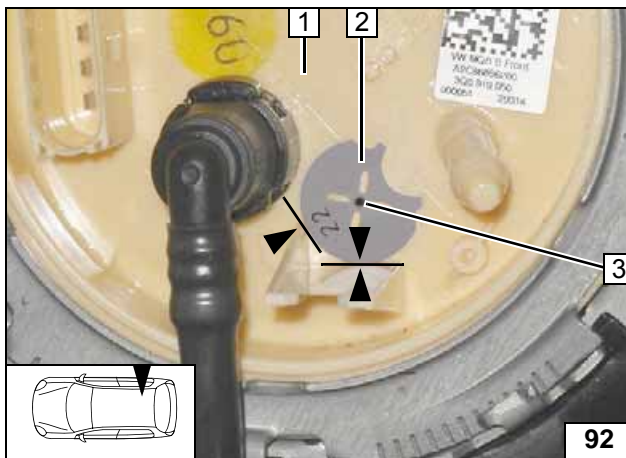

Work steps F1 and F2.

- 1 Fuel tank sending unit
- 2 Position template with outer dia.  $d_a = 22\text{mm}$  at the markings.
- 3 Hole pattern



Copying hole pattern

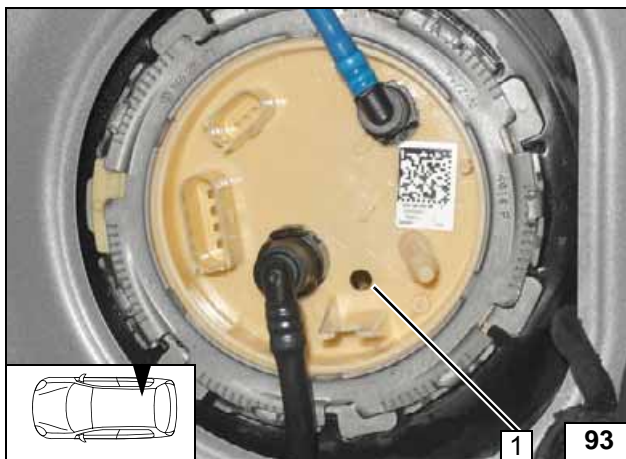

Work step F3.

- 1 Hole made with provided drill

Hole for FuelFix

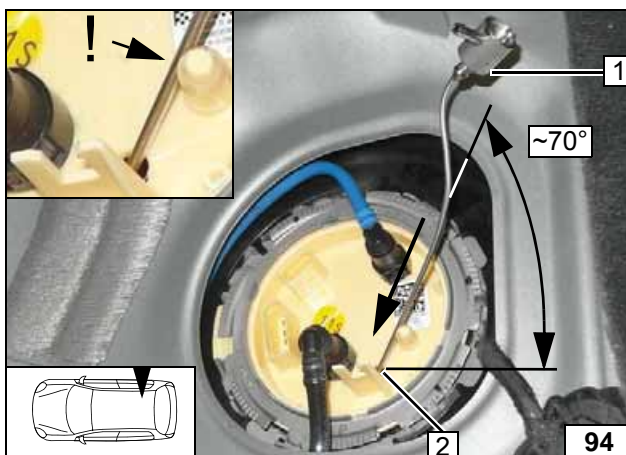

Work steps F4 and F5.

Bend FuelFix 1 according to template and cut to length. Insert into hole 2.



Inserting FuelFix





Work step F5.

Inserting  
FuelFix

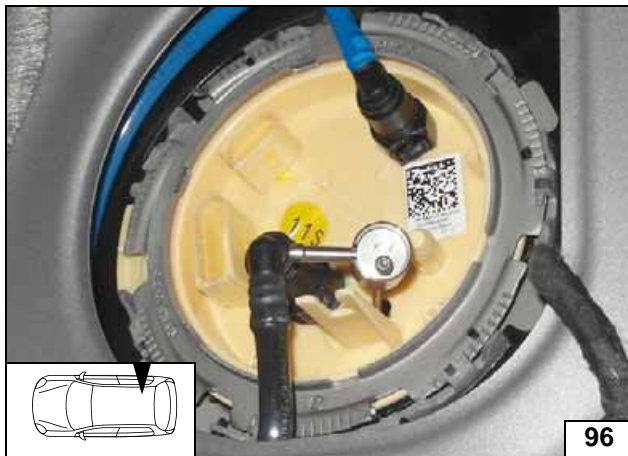

Inserting  
FuelFix

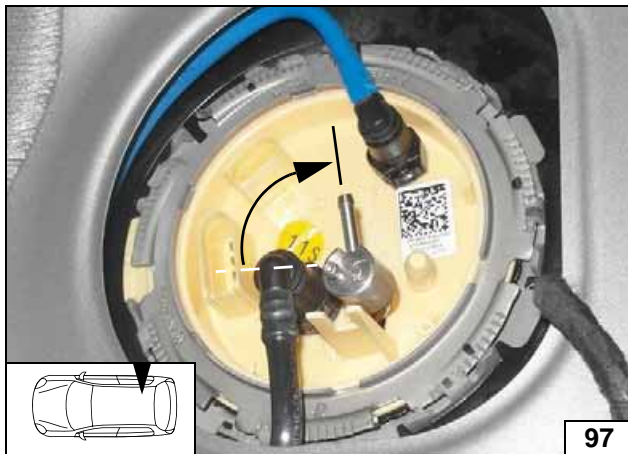

Inserting  
FuelFix

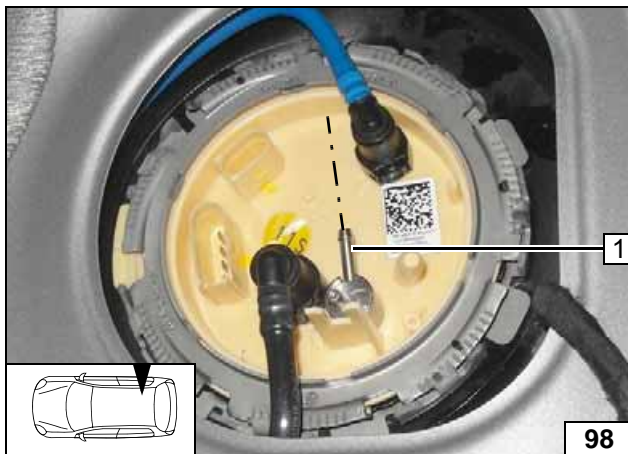

Work steps F5.3 and F5.4.

Align FuelFix 1 as shown.



Aligning  
FuelFix

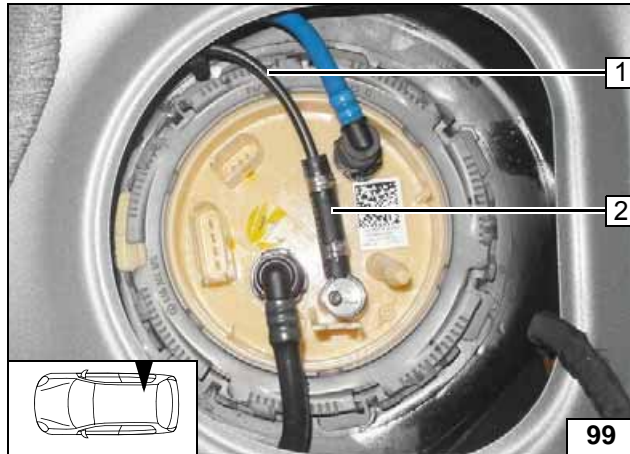

Work step F6.

- 1 Fuel line
- 2 Hose section, 10mm dia. clamp [2x]

Connect-  
ing fuel line

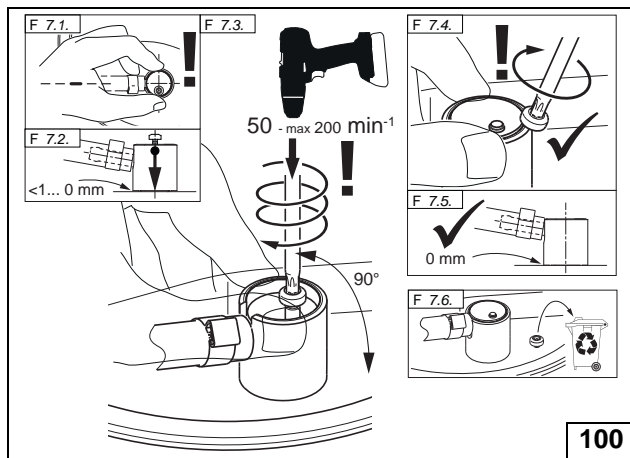

Work step F7.



Installing  
FuelFix



Work step F8.

Ensuring  
firm seating  
of FuelFix

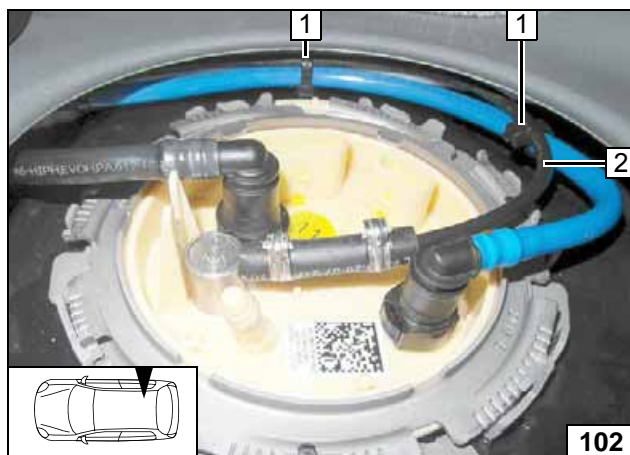

- 1 Cable tie as tension relief [2x]
- 2 Fuel line

Securing fuel  
line

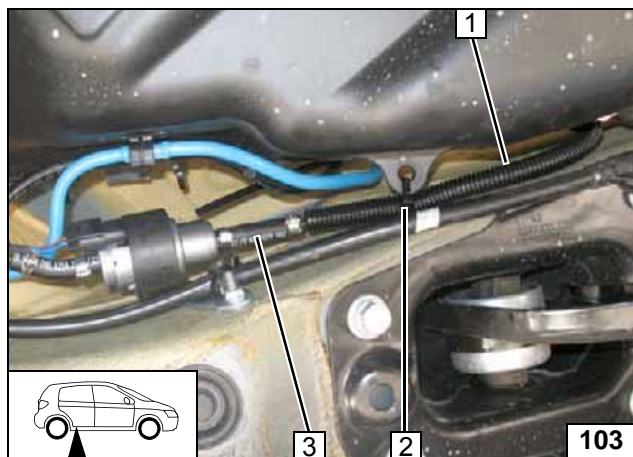

Slide 10 mm dia. corrugated tube **1** onto fuel line. Check the position of the components; adjust if necessary. Check that they have freedom of movement.

- 2** Cable tie as tension relief
- 3** Fuel line of FuelFix, hose section, 10mm dia. clamp [2x]

**Connect-  
ing meter-  
ing pump**



### TSI Coolant Circuit







Any coolant running off should be collected in an appropriate container. Route hoses kink-free. Unless specified otherwise, always fasten using cable ties. Position clamps so that other hoses cannot be damaged. The heater must be filled with coolant when installing the hoses.

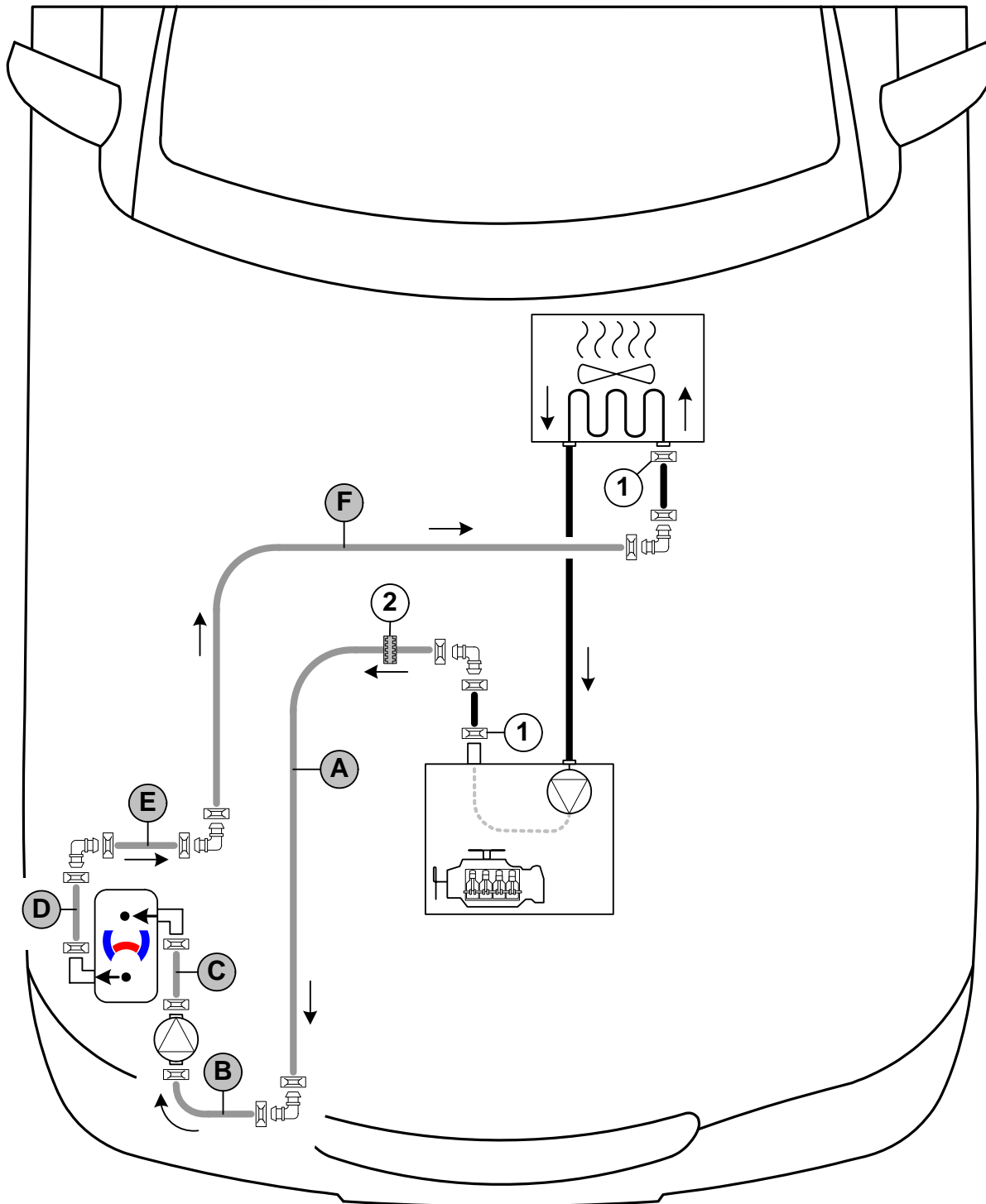

The connection should be modelled on an 'inline' circuit and based on the following diagram:



Hose routing diagram

All spring clips without a specific designation  = 25 mm dia. All connecting pipes  and  = 18x18mm dia.  
 1 = Original vehicle spring clip .  
 2 = Black (sw) rubber isolator  only for Passat and Superb!





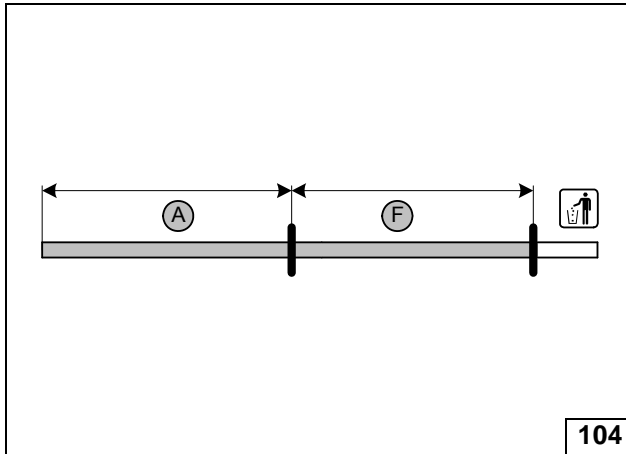

A = 1070  
F = 990

Cutting hoses to length

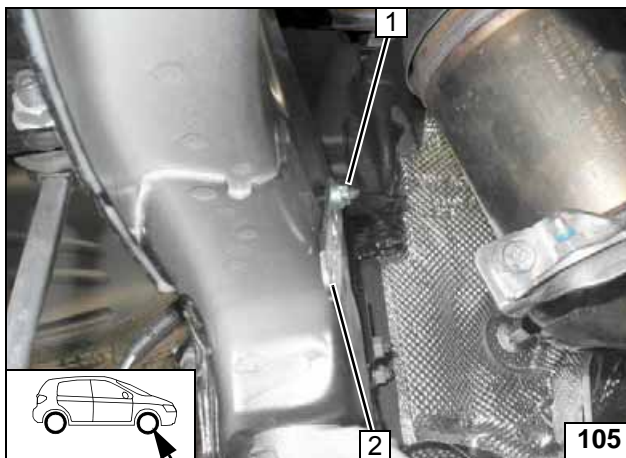

- 1 M6 flanged nut, original vehicle stud bolt
- 2 Perforated bracket

Installing perforated bracket

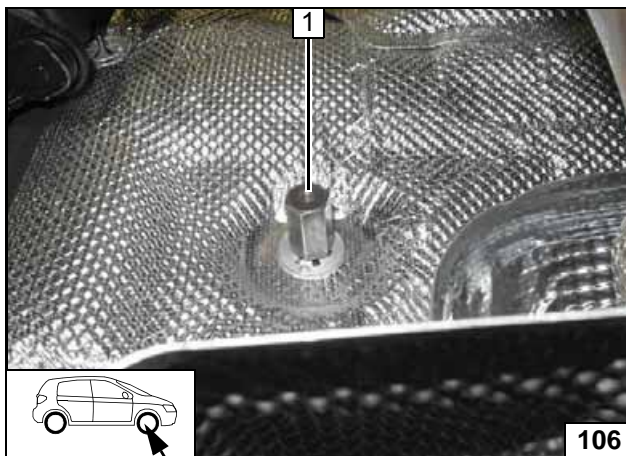

- 1 M6x30 spacer nut, original vehicle stud bolt

Installing spacer nut

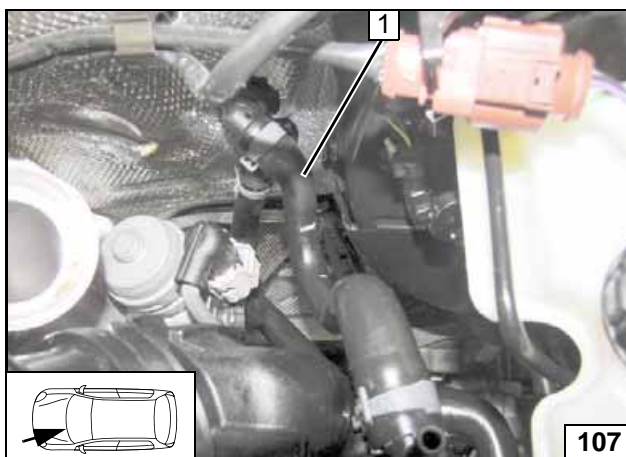

**Golf VII / Golf VII Sportsvan, Version 1**

Remove engine outlet / heat exchanger inlet hose 1. Spring clips will be reused!



Cutting point

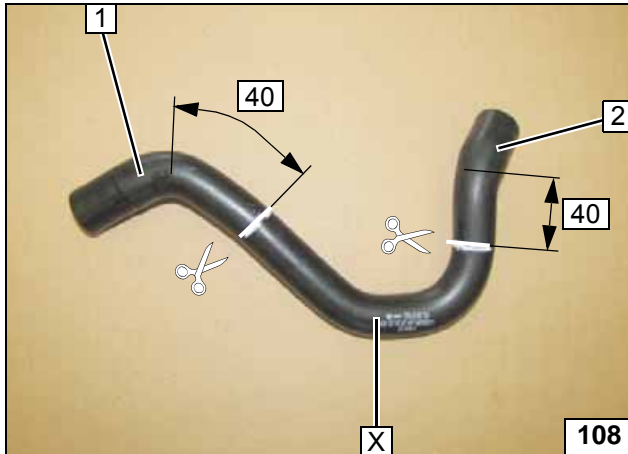

- 1 Engine outlet hose section
- 2 Heat exchanger inlet hose section

X =

Cutting point

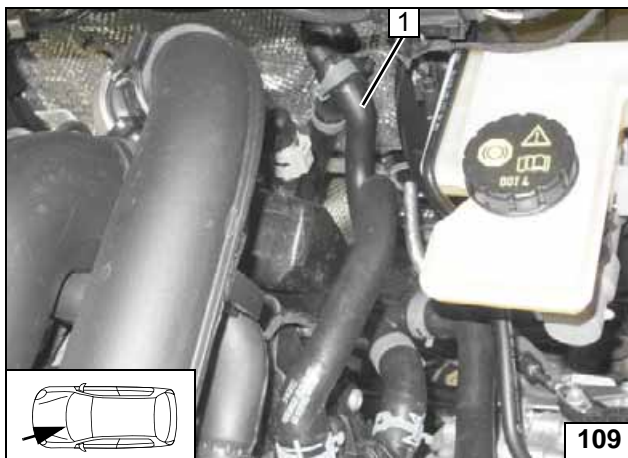

**Golf VII / Golf VII Sportsvan, Version 2**

Remove engine outlet / heat exchanger inlet hose 1. Spring clips will be reused!

Cutting point

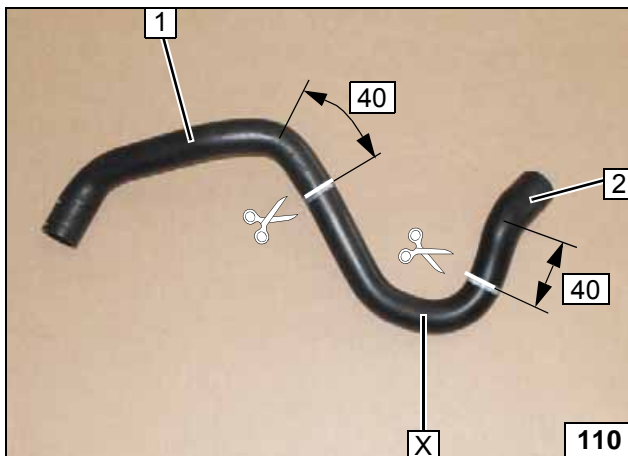

- 1 Engine outlet hose section
- 2 Heat exchanger inlet hose section

X =

Cutting point

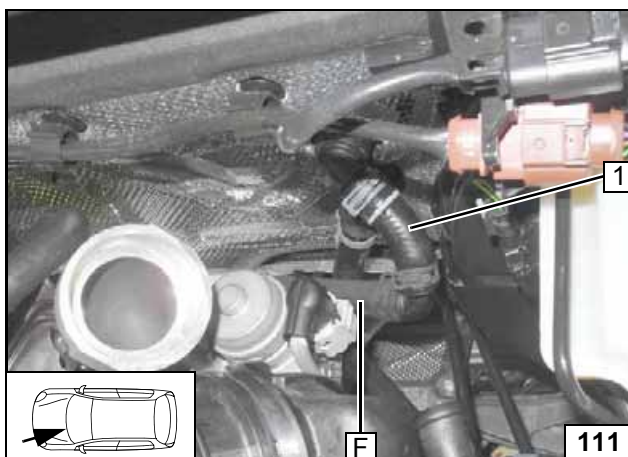

**Golf VII / Golf VII Sportsvan**

- 1 Heat exchanger inlet hose section

Connecting heat exchanger inlet

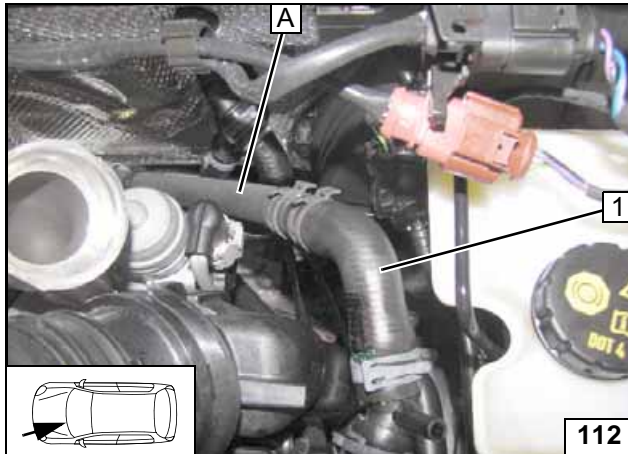

1 Engine outlet hose section

Connect-  
ing engine  
outlet



Passat / Superb

Remove engine outlet / heat exchanger in-  
let hose 1. Spring clips will be reused!



Cutting  
point

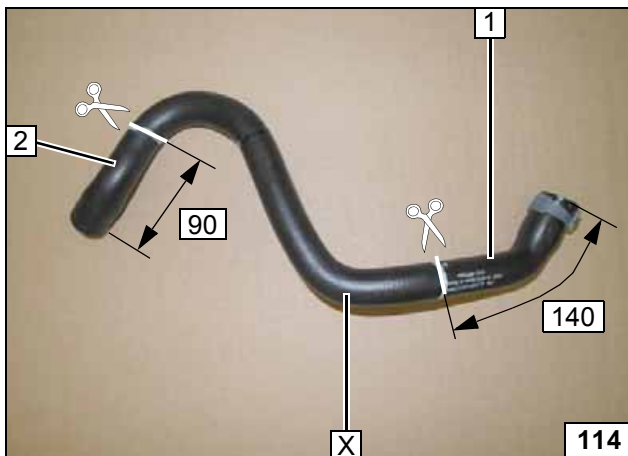

1 Engine outlet hose section  
2 Heat exchanger inlet hose section

X =

Cutting  
point

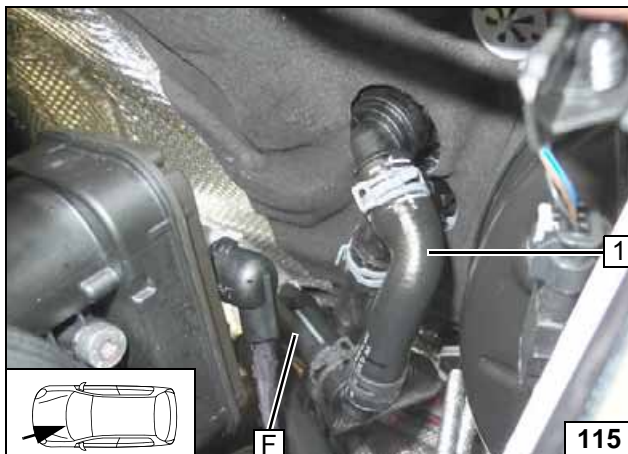

1 Heat exchanger inlet hose section

Connect-  
ing heat ex-  
changer  
inlet



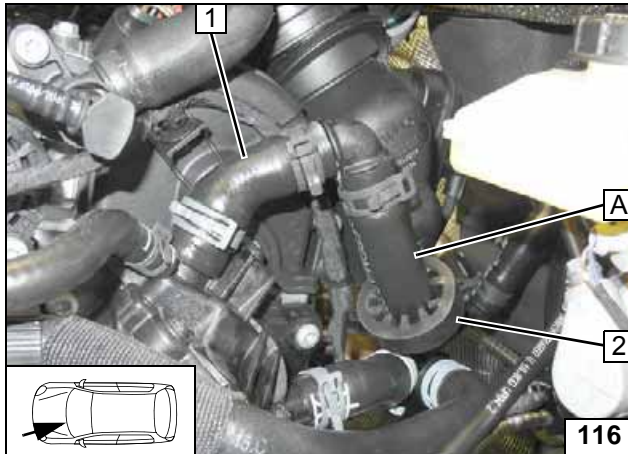

- 1 Engine outlet hose section
- 2 Position black (sw) rubber profile

Connect-  
ing engine  
outlet

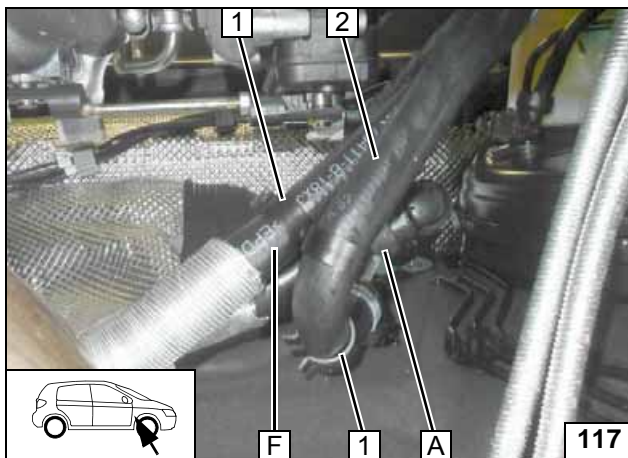

**All vehicles**

Slide one 600mm long heat protection hose each onto hoses **A** and **F**.

- 1 Twistable spacer bracket [2x]
- 2 Hose of heat exchanger outlet



Routing on  
firewall

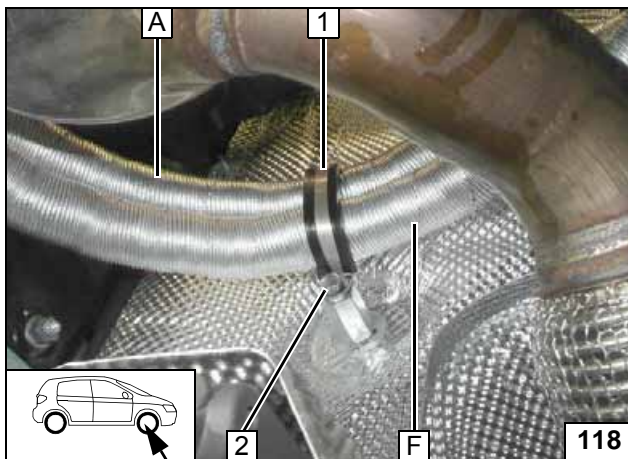

- 1 48 mm dia. rubber-coated p-clamp
- 2 M6x20 bolt, spring lockwasher

Fastening on  
firewall

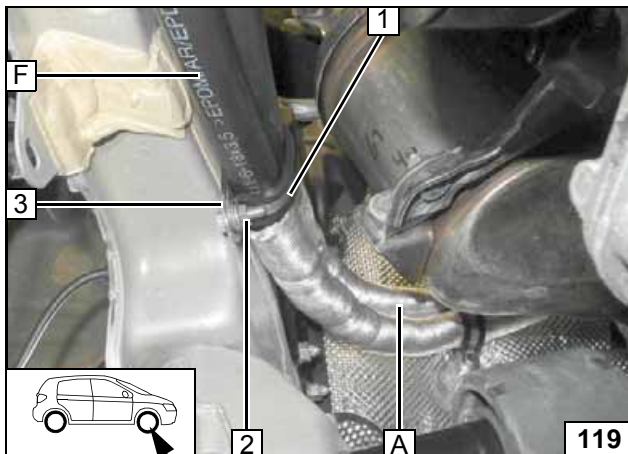

Align hoses. Ensure sufficient distance to catalytic converter, correct if necessary.

- 1 38 mm dia. rubber-coated p-clamp
- 2 M6x20 bolt, flanged nut
- 3 Perforated bracket



Routing on  
frame side  
member



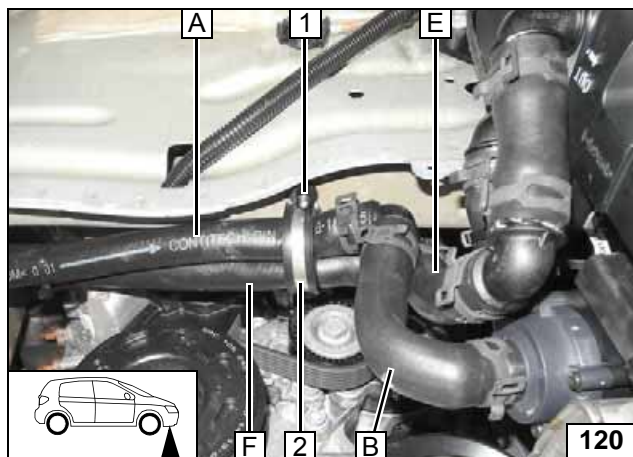

Ensure sufficient distance from neighbouring components, correct if necessary.



- 1 Original vehicle stud bolt, plastic nut
- 2 38 mm dia. rubber-coated p-clamp

**Aligning hoses**



### Coolant Circuit for TDI Front-Wheel Drive



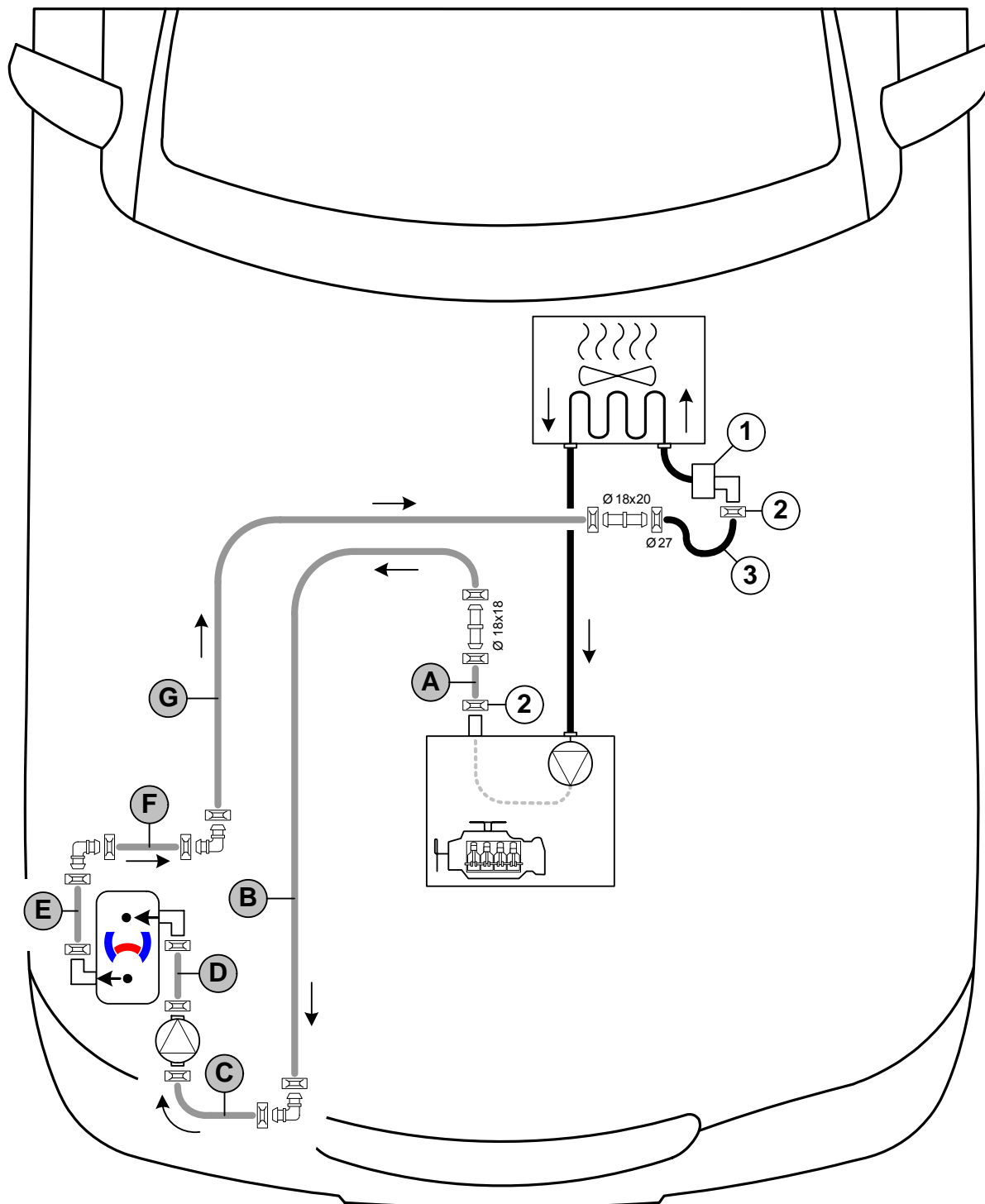

Any coolant running off should be collected in an appropriate container. Route hoses kink-free. Unless specified otherwise, always fasten using cable ties. Position clamps so that other hoses cannot be damaged. The heater must be filled with coolant when installing the hoses.

The connection should be modelled on an 'inline' circuit and based on the following diagram:



Hose routing diagram

All spring clips without a specific designation  = 25 mm dia. All connecting pipes  = 18x18 mm dia.

1 = EGR!

2 = Original vehicle spring clip .

3 = Original vehicle hose



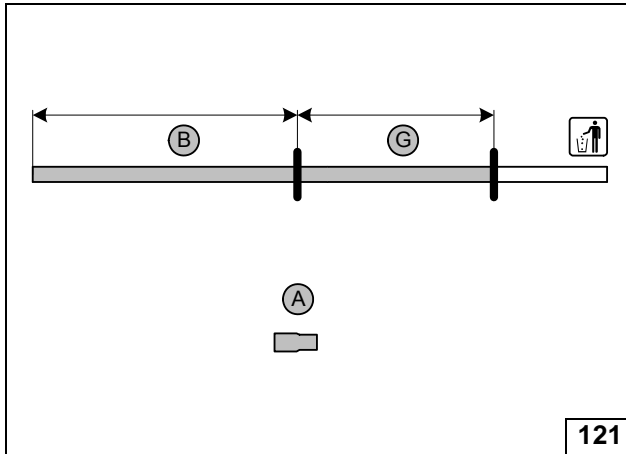

- A = 18x20mm dia.
- B = 1020
- G = 980

Cutting hoses to length

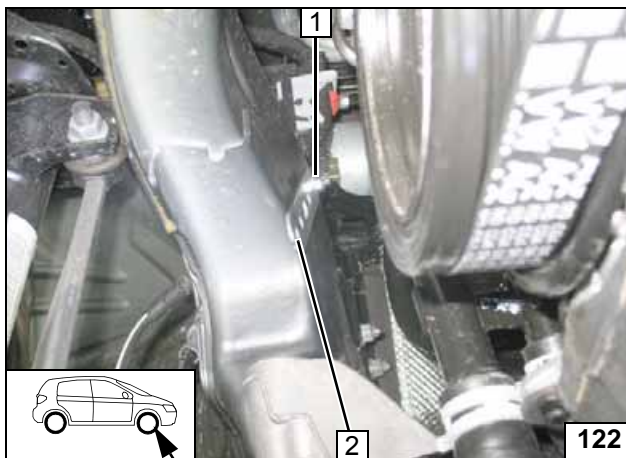

- 1 M6 flanged nut, original vehicle stud bolt
- 2 Perforated bracket

Installing perforated bracket

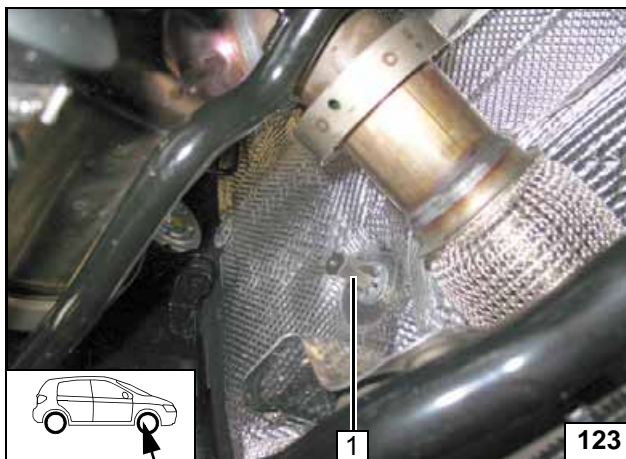

- 1 M6x30 spacer nut, original vehicle stud bolt

Installing spacer nut

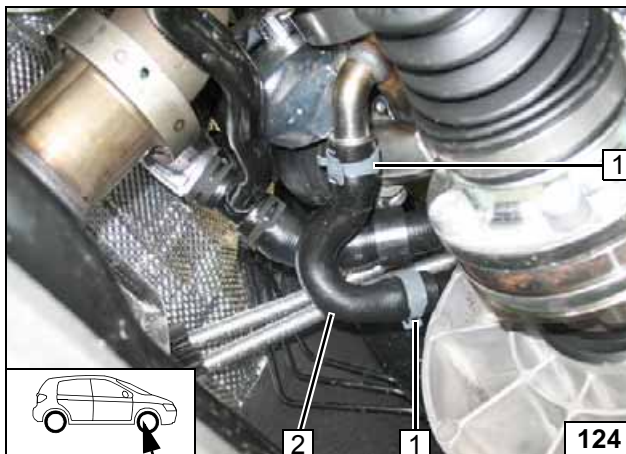

Remove hose from engine outlet / EGR inlet 2. Spring clips 1 will be reused.



Cutting point

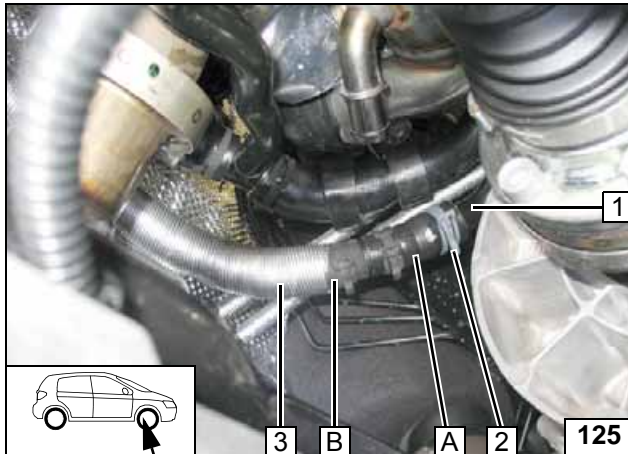

Slide 600mm long heat protection hose 3 onto hose B.

- 1 Pipe of engine outlet
- 2 Original vehicle spring clip



**Connect-  
ing engine  
outlet**

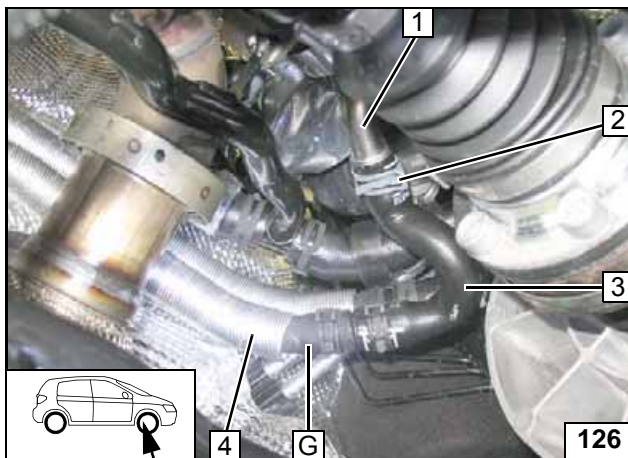

Slide 600mm long heat protection hose 4 onto hose B.

- 1 Pipe of EGR
- 2 Original vehicle spring clip
- 3 Original vehicle hose



**Connect-  
ing heat ex-  
changer  
inlet**

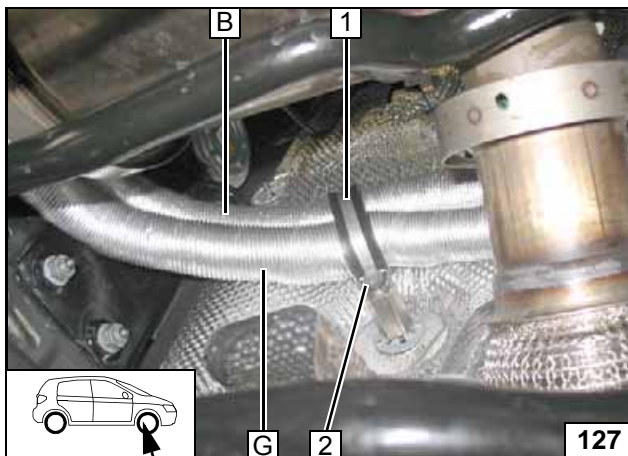

- 1 48 mm dia. rubber-coated p-clamp
- 2 M6x20 bolt, spring lockwasher

**Fastening on  
firewall**

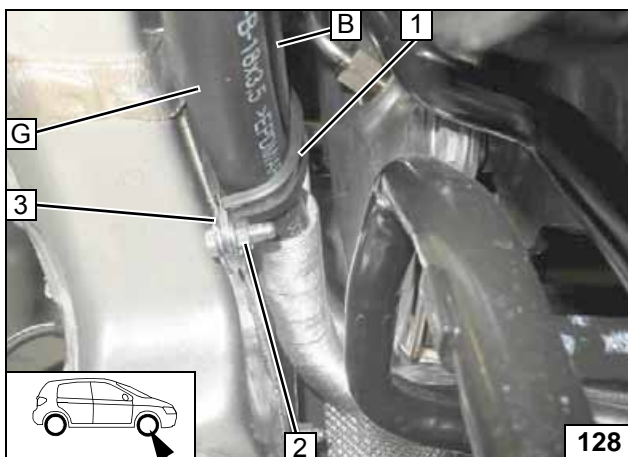

- 1 38 mm dia. rubber-coated p-clamp
- 2 M6x20 bolt, flanged nut
- 3 Perforated bracket

**Routing on  
frame side  
member**





Align hoses. Ensure sufficient distance to catalytic converter at position 1, correct if necessary.



**Routing in engine compartment**

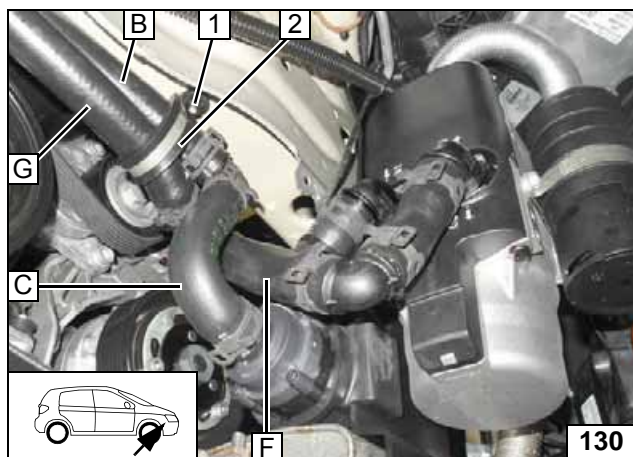

Align hoses. Ensure sufficient distance from neighbouring components, correct if necessary.



- 1 Original vehicle stud bolt, plastic nut
- 2 38 mm dia. rubber-coated p-clamp

**Connect-  
ing heater  
outlet and  
inlet**



### Coolant Circuit for Superb 2.0 TDI 4x4 and 1.6 TDI



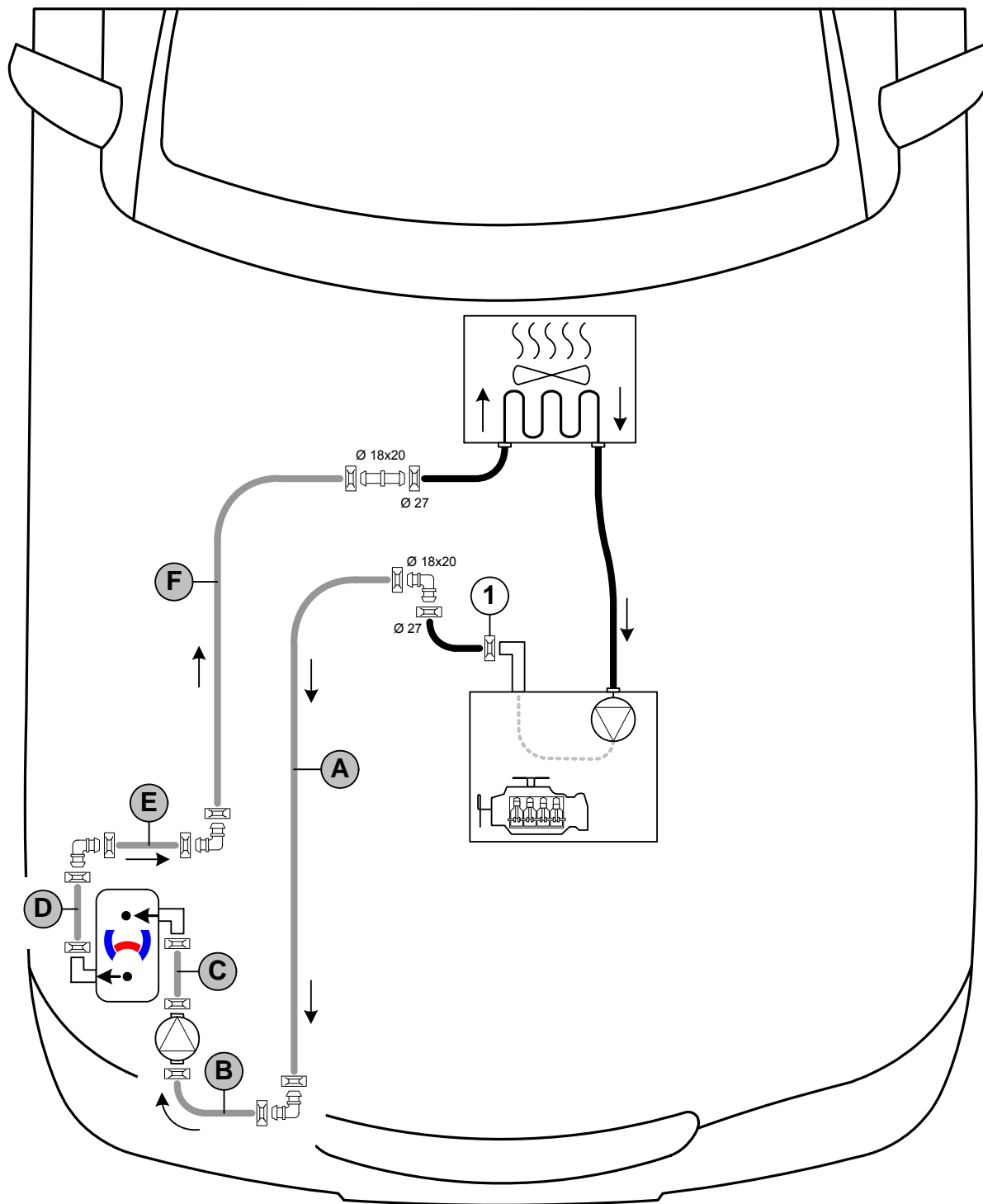

Any coolant running off should be collected in an appropriate container. Route hoses kink-free. Unless specified otherwise, always fasten using cable ties. Position clamps so that other hoses cannot be damaged. The heater must be filled with coolant when installing the hoses.

The connection should be modelled on an 'inline' circuit and based on the following diagram:



Hose routing diagram

All spring clips without a specific designation  = 25 mm dia.  
 All connecting pipes without a specific designation  = 18x18 mm dia.  
 1 = Original vehicle spring clip .



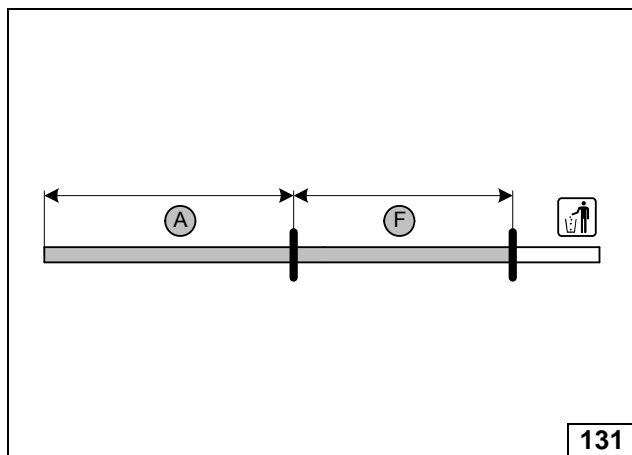

A = 920  
F = 910

Cutting hoses to length

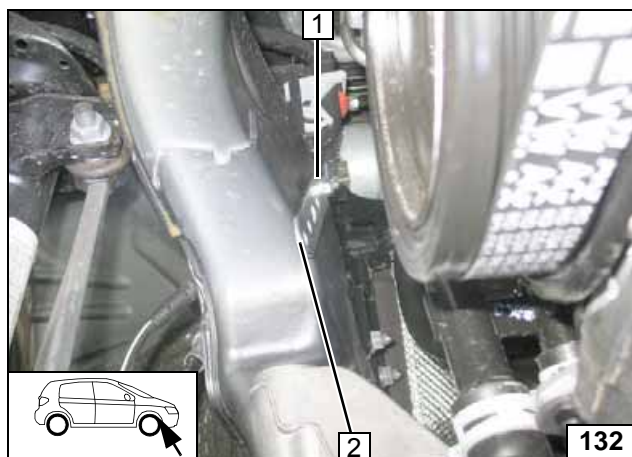

- 1 M6 flanged nut, original vehicle stud bolt
- 2 Perforated bracket

Installing perforated bracket

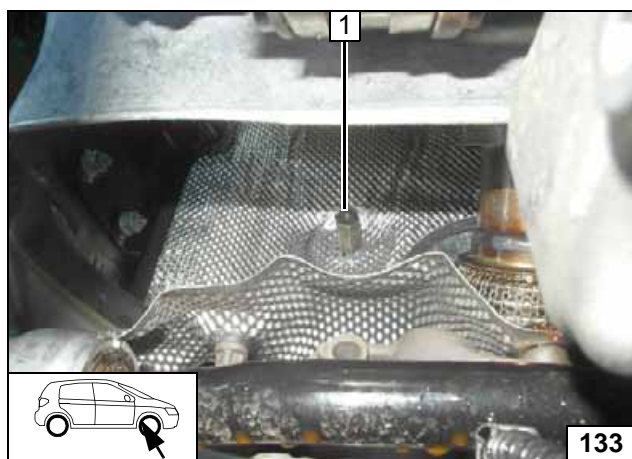

- 1 M6x30 spacer nut, original vehicle stud bolt

Installing spacer nut

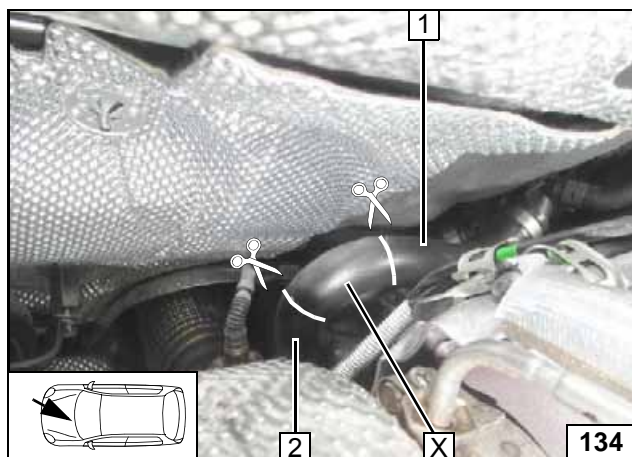

Cut off hose of engine outlet / heat exchanger inlet at the markings. Remove hose section of engine outlet 2. The spring clip of the engine outlet connection piece will be reused!

- 1 Heat exchanger inlet hose section

X =



Cutting point

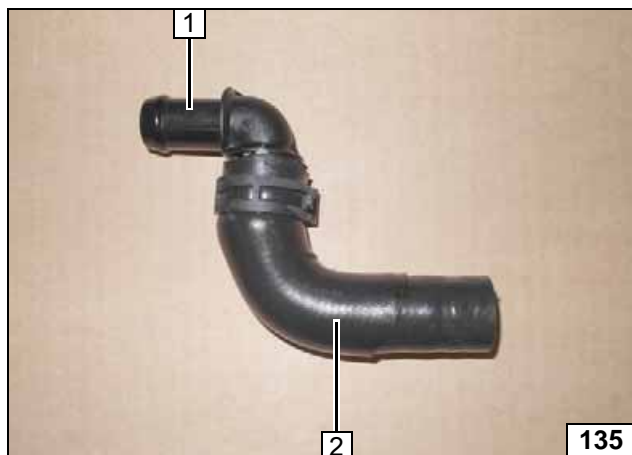
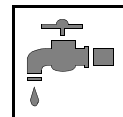

- 1 90°, 18x20mm dia. connecting pipe, 27mm dia. spring clip
- 2 Engine outlet hose section

**Preparing engine outlet hose section**

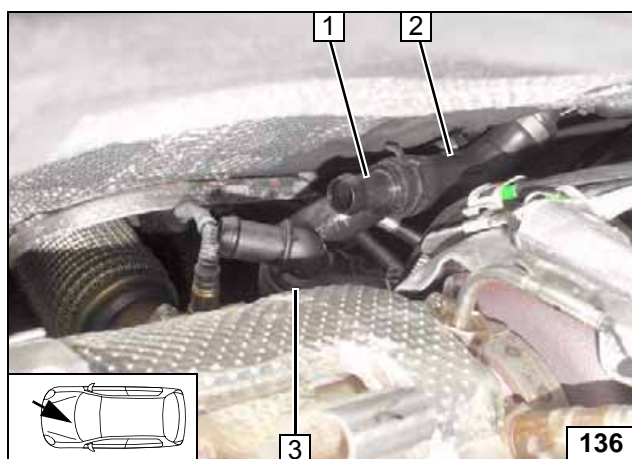

Install hose section of engine outlet 3 with original vehicle spring clip on engine outlet.



- 1 18x20mm dia. connecting pipe, 27mm dia. spring clip
- 2 Heat exchanger inlet hose section

**Installing engine outlet hose section**

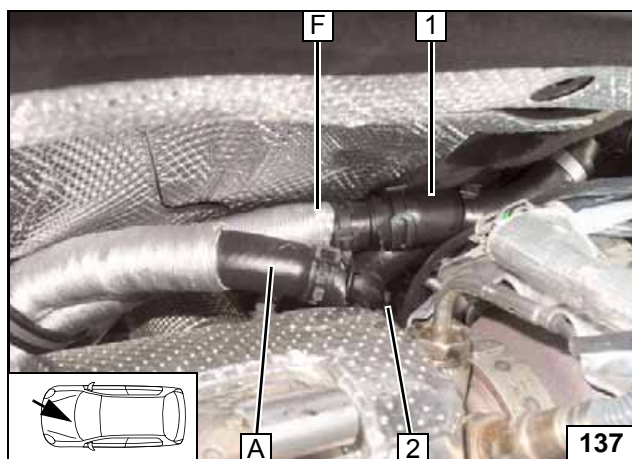

Slide one 600mm long heat protection hose each onto hoses A and F.



- 1 Heat exchanger inlet hose section
- 2 Original vehicle spring clip

**Connecting engine outlet / heat exchanger inlet**

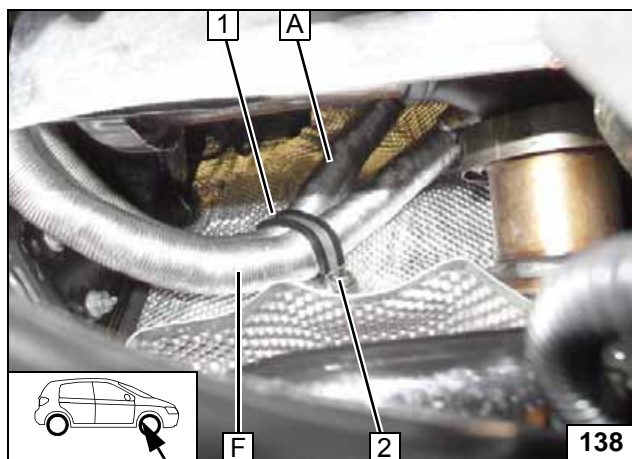

- 1 48 mm dia. rubber-coated p-clamp
- 2 M6x20 bolt, spring lockwasher

**Fastening on firewall**



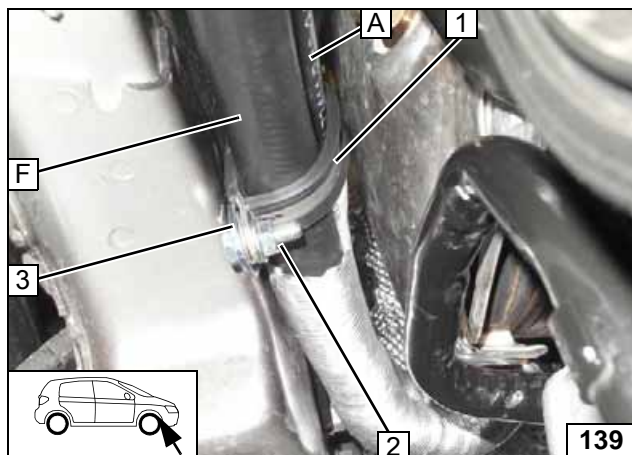
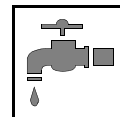

- 1 38 mm dia. rubber-coated p-clamp
- 2 M6x20 bolt, flanged nut
- 3 Perforated bracket

**Routing on frame side member**

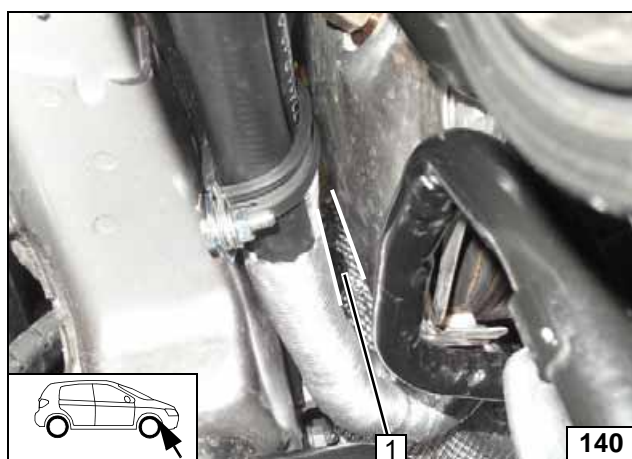

Align hoses. Ensure sufficient distance to catalytic converter at position 1, correct if necessary.



**Routing in engine compartment**

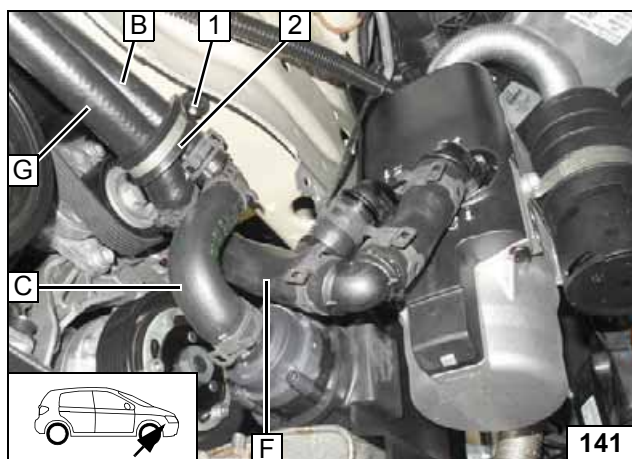

Align hoses. Ensure sufficient distance from neighbouring components, correct if necessary.



- 1 Original vehicle stud bolt, plastic nut
- 2 38 mm dia. rubber-coated p-clamp

**Connecting heater outlet and inlet**

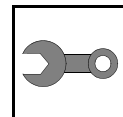

## Final Work



Reassemble the components in reverse order. Check all hoses, clamps and all electrical connections for firm seating. Insulate and tie back loose lines.  
Only use manufacturer-approved coolant. Spray the heater components with anti-corrosion wax (Tectyl 100K).

- **Connect the battery.**
- **Fill and bleed the coolant circuit according to the vehicle manufacturer's instructions.**
- **Program MultiControl CAR, teach Telestart transmitter.**
- **For initial startup and function check, please see installation instructions.**
- **If the fan function or A/C control panel settings need to be checked, see the installation documentation in the additional kit 'Webasto Standard' or 'Webasto Comfort' A/C control, section 'Final Work'.**
- **Place the 'Switch off parking heater before refuelling' caution label near the filler neck.**

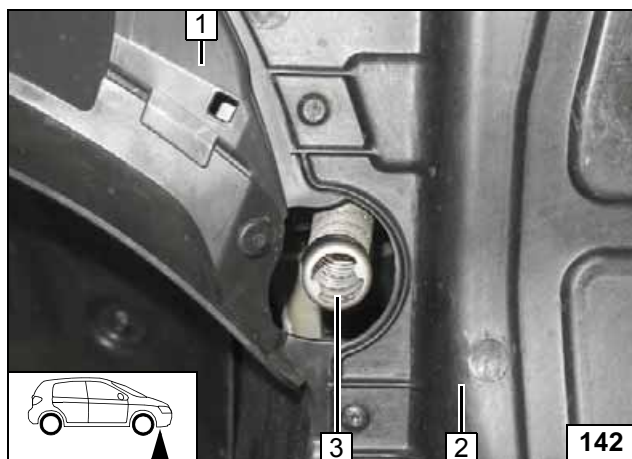

Align exhaust outlet 3 with centre of pass through.

- 1 Wheel well trim installed
- 2 Underride protection installed



**Aligning exhaust pipe**

Webasto Thermo & Comfort SE  
Postfach 1410  
82199 Gilching  
Germany  
Internet: [www.webasto.com](http://www.webasto.com)  
Technical Extranet:  
<http://dealers.webasto.com>



FuelFix Template for TSI

Top view

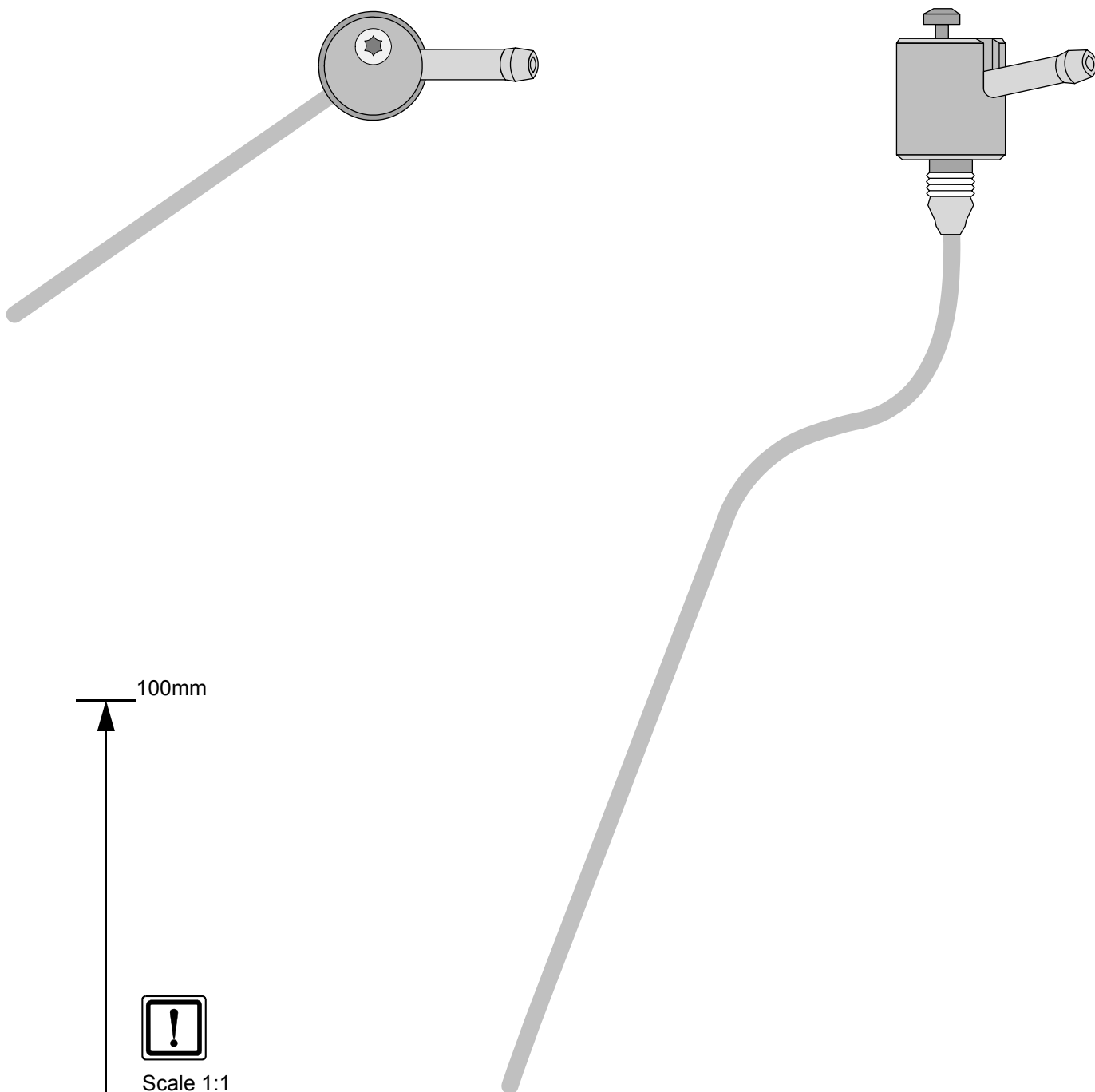

Scale 1:1

Compare size of printout with dimension lines.  
Allowed tolerance a maximum of 2%.

Set the printer settings to 'no margin' or 'minimise margins' and 100% of the normal size.

100mm

100mm

0



FuelFix Template for TDI Golf VII / Golf VII Sportsvan

Top view

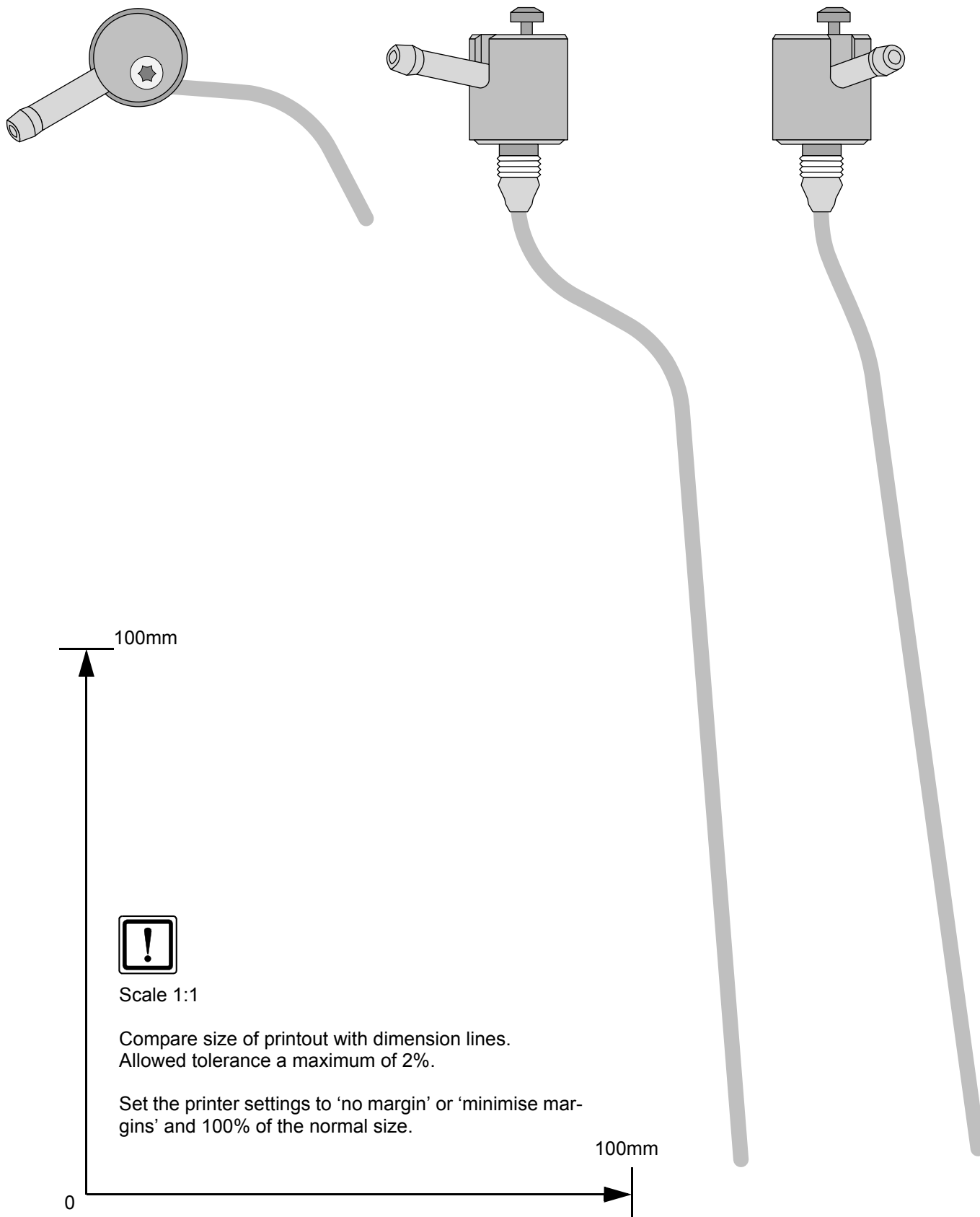





FuelFix Template for TDI Passat / Superb Front-Wheel Drive

Top view

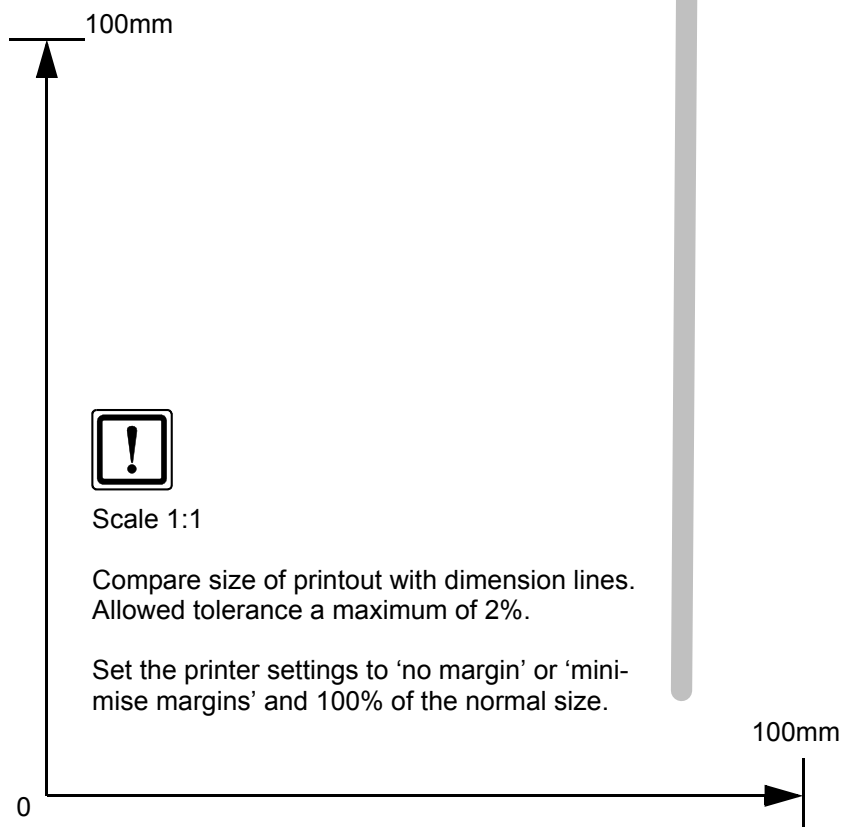
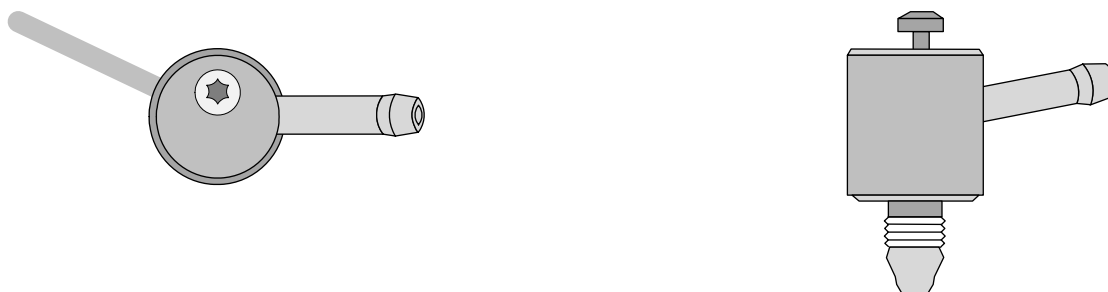



FuelFix Template for TDI Superb 4x4

Top view

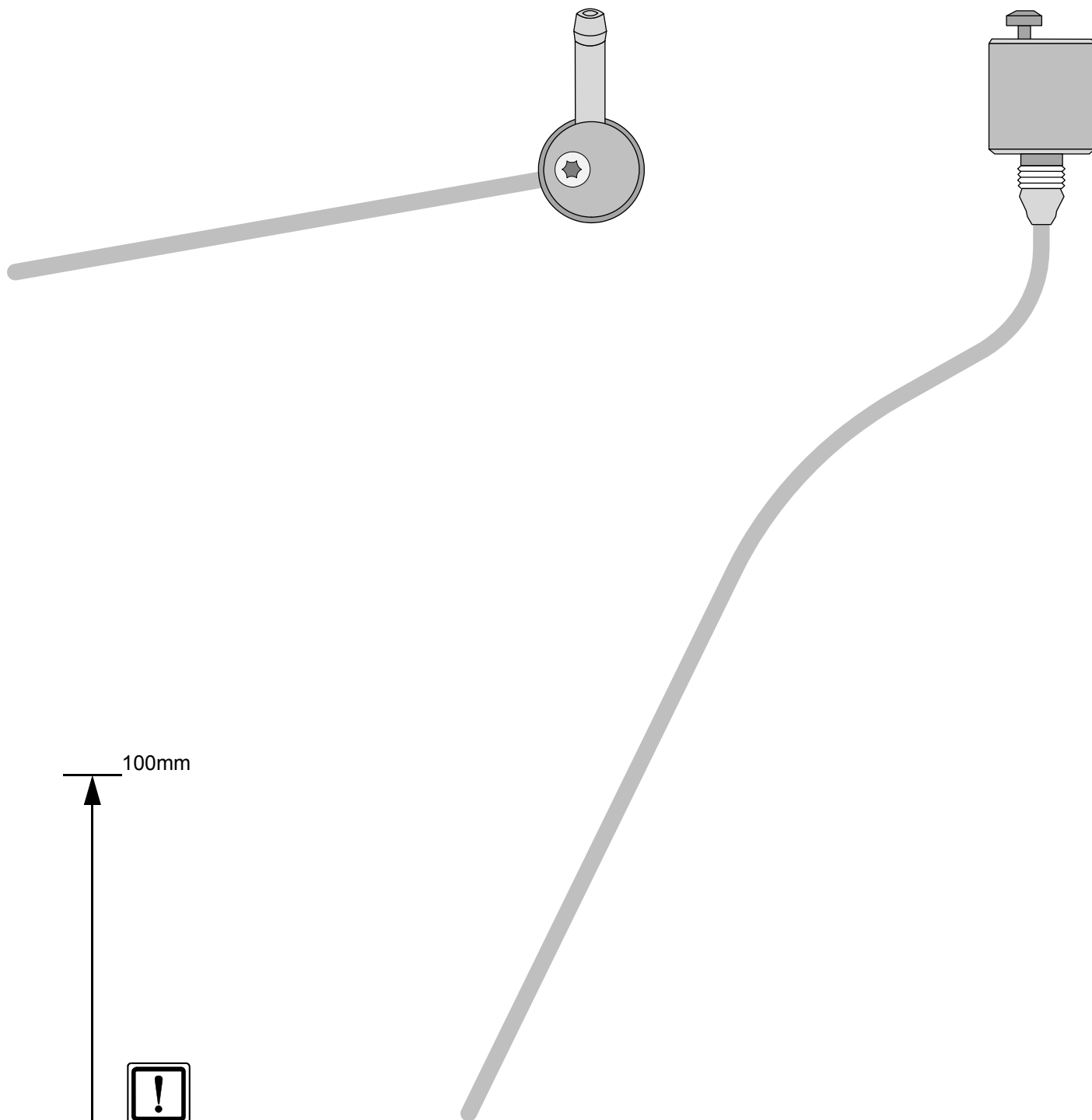

100mm



Scale 1:1

Compare size of printout with dimension lines.  
Allowed tolerance a maximum of 2%.

Set the printer settings to 'no margin' or 'minimise margins' and 100% of the normal size.

100mm

0