



Water heater

Thermo Top Evo parking heater



Installation documentation

VW Golf VII / Golf VII Sportsvan / Passat and Skoda Superb MQB

Validity

Manufacturer	Model	Type	Model year	EG BE No. / ABE
VW	Golf VII	AU	from 2013 up to 2016	e1 * 2007 / 46 * 0623 * ...
VW	Golf VII Variant	AUV	from 2013 up to 2016	e1 * 2007 / 46 * 0627 * ...

Motorisation	Fuel	Emission standard	Transmission type	Output in kW	Displacement in cm ³	Engine code
1.2 TSI	Petrol	Euro 6	5-speed SG	63	1197	CJZB
1.2 TSI	Petrol	Euro 6	6-speed SG	77	1197	CJZA
1.4 TSI	Petrol	Euro 5	DSG	90	1395	CMBA / CUKA
1.4 TSI	Petrol	Euro 5	6-speed SG	90	1395	CMBA / CXSA
1.4 TSI	Petrol	Euro 5	6-speed SG	103	1395	CHPA
1.4 TSI	Petrol	Euro 5	DSG	103	1395	CPTA
1.6 TDI	Diesel	Euro 5	5-speed SG	77	1598	CLHA
1.6 TDI	Diesel	Euro 5	6-speed SG	81	1598	CRKB
2.0 TDI	Diesel	Euro 5	DSG	110	1968	CRBC
1.6 TDI	Diesel	Euro 6	6-speed SG	81	1598	DDYA
1.6 TDI Blue	Diesel	Euro 6	6-speed SG	81	1598	CRKB
2.0 TDI Blue	Diesel	Euro 6	DSG	110	1968	CRBC

Manufacturer	Model	Type	Model year	EG BE No. / ABE
VW	Golf VII	AU	from 2017	e1 * 2007 / 46 * 0623 * ...
VW	Golf VII Variant	AUV	from 2017	e1 * 2007 / 46 * 0627 * ...

Motorisation	Fuel	Emission standard	Transmission type	Output in kW	Displacement in cm ³	Engine code
1.0 TSI	Petrol	Euro 6	DSG	85	999	CHZD
1.0 TSI	Petrol	Euro 6	6-speed SG	85	999	CHZC
1.4 TSI	Petrol	Euro 6	6-speed SG	110	1395	CZEA
1.4 TSI	Petrol	Euro 6	DSG	110	1395	CZDA
1.5 TSI	Petrol	Euro 6d-temp	DSG	110	1498	DADA
1.6 TDI	Diesel	Euro 6	6-speed SG	85	1598	DDYA
1.6 TDI	Diesel	Euro 6	DSG	85	1598	DDYA
2.0 TDI	Diesel	Euro 6	6-speed SG	110	1968	DCYA
2.0 TDI (BlueMotion)	Diesel	Euro 6	DSG	110	1968	CRLB

VW Golf VII / Golf VII Sportsvan / Passat and Skoda Superb

Manufacturer	Model	Type	Model year	EG BE No. / ABE
VW	Golf VII Sportsvan	AUV	From model year 2014	e1 * 2007 / 46 * 0627 * ...

Motorisation	Fuel	Emission standard	Transmission type	Output in kW	Displacement in cm ³	Engine code
1.2 TSI	Petrol	Euro 6	5-speed SG	63	1197	CJZB
1.4 TSI	Petrol	Euro 6	DSG	92	1395	CZCA
1.6 TDI	Diesel	Euro 5	5-speed SG	81	1598	CRKB
1.6 TDI (BlueMotion)	Diesel	Euro 6	6-speed SG	81	1598	CRKB
2.0 TDI (BlueMotion)	Diesel	Euro 6	DSG	110	1968	CRLB

SG = manual transmission

DSG = direct gear transmission

Left-hand drive vehicle

Verified equipment variants: Climatic (only for Golf VII)
 Climatronic
 Front fog lights
 Start - Stop (for Golf VII only)
 Passenger compartment monitoring (can be turned off)
 Xenon / headlight washer system
 LED main headlights

Not verified: Passenger compartment monitoring
 4Motion

Exclusion: Heavy-duty running gear incl. stoneguard

Total installation time: approx. 7 hours

VW Golf VII / Golf VII Sportsvan / Passat and Skoda Superb

Manufacturer	Model	Type	Model year	EG BE No. / ABE
VW	Passat / Passat Variant	3C / 3G	From model year 2015	e1 * 2001 / 116 * 0307 * ...

Motorisation	Fuel	Emission standard	Transmission type	Output in kW	Displacement in cm ³	Engine code
1.4 TSI	Petrol	Euro 6	DSG	110	1395	CZEA
2.0 TDI	Diesel	Euro 5	DSG	110	1968	CRLB
2.0 TDI	Diesel	Euro 5	DSG	140	1968	DDAA
2.0 TDI Blue	Diesel	Euro 6	DSG	110	1968	CRLB
2.0 TDI Blue	Diesel	Euro 6	DSG	140	1968	DDAA

DSG = direct gear transmission

Left-hand drive vehicle

Verified equipment variants: Climatronic
 Front fog lights
 Start - Stop
 Turning light
 LED headlight
 Headlight washer system (diesel only)

Not verified: Climatic
 Passenger compartment monitoring
 Headlight washer system (petrol only)
 Rough road package

Exclusion: 4Motion

Total installation time: approx. 7.5 hours

VW Golf VII / Golf VII Sportsvan / Passat and Skoda Superb

Manufacturer	Model	Type	Model year	EG BE No. / ABE
Skoda	Superb	3T / 3V	From model year 2015	e11 * 2001 / 116 * 0326 * ...

Motorisation	Fuel	Emission standard	Transmission type	Output in kW	Displacement in cm ³	Engine code
1.4 TSI	Petrol	Euro 6	6-speed SG	110	1395	CZEA
1.6 TDI	Diesel	Euro 6	DSG	88	1598	DCXA
2.0 TDI	Diesel	Euro 6	6-speed SG	110	1968	CRLB
2.0 TDI	Diesel	Euro 6	DSG	110	1968	CRLB
2.0 TDI	Diesel	Euro 6	DSG	140	1968	DFCA

SG = manual transmission

DSG = direct gear transmission

Left-hand drive vehicle

Verified equipment variants: Climatronic
 Multi-zone Climatronic
 Front fog lights
 Start - Stop
 Xenon headlights
 Turning light
 Headlight washer system
 4x4

Not verified: Climatic
 Passenger compartment monitoring

Total installation time: approx. 7.5 hours

VW Golf VII / Golf VII Sportsvan / Passat and Skoda Superb

Table of contents

Validity	1	Preparing installation location	19
Necessary components	5	Installing heater assembly	20
Installation instructions	5	Fuel	23
Information on total installation time	5	FuelFix installation for TSI	27
Information on operating and installation instructions	6	Installing FuelFix for Golf VII / Golf VII Sportsvan TDI	30
Information on validity	7	Installing FuelFix for Passat / Superb TDI Front-Wheel Drive	33
Technical information	7	Installing FuelFix for Superb TDI 4x4	36
Explanatory notes on document	7	Coolant circuit for 1.0 / 1.2 / 1.4 TSI	40
Preliminary work for Golf VII / Golf VII Sportsvan	8	Coolant circuit for 1.5 TSI	46
Preliminary work for Passat	8	Coolant circuit for TDI front-wheel drive	51
Preliminary work for Superb	9	Coolant circuit for Superb 2.0 TDI 4x4 and 1.6 TDI	55
Heater assembly installation location	9	Final work	59
Preparing electrical system	10	FuelFix template for TSI	61
Electrical system	12	FuelFix template for TDI Golf VII/ Sportsvan/ Superb 4x4	62
Air-conditioning control	13	FuelFix template for TDI Passat / Superb front-wheel drive	63
Control elements for Golf VII	13		
Control elements for Sportsvan	15		
Control elements for Passat/ Superb	16		

Necessary components

Description	Order No.:
Delivery scope for VW / Skoda / Seat / petrol 2013 TT-Evo	1325108B
Delivery scope for Golf / Passat / Superb diesel 2013 TT-Evo	1325106B
Additional 'Webasto Standard' A/C control kit for VW / Skoda / Seat MQB with Climatic and Climatronic or Additional 'Webasto Comfort' A/C control kit for VW / Skoda / Seat MQB with Climatronic	1325085_ 1325012_
In case of Telestart, control element, as well as indicator lamp in consultation with end customer	In accordance with price list
In case of installation of MultiControl CAR - MultiControl installation frame	9030077_

Webasto individual option

Description	Order No.:
Additional Webasto Individual Auxiliary Heating kit	1320077_
Additional Webasto Individual Quick kit	9030826_
Additional Webasto Individual Select kit	9030828_

Installation instructions

Arrange for the vehicle to be delivered with the tank only about ¼ full.

The installation location of the push button in case of Telestart or ThermoCall should be confirmed with the end customer. Depending on the space required and the vehicle manufacturer's instructions, we recommend the use of a vehicle battery with a higher electrical capacity.

Ensure sufficient distance from original vehicle components when installing the premounted heater assembly, correct if necessary.

Golf VII / Golf VII Sportsvan

Pictures used for the installation steps are of a 1.6TDI vehicle. Deviations are documented separately!

Passat / Superb

Pictures used for the installation steps are of a 2.0TDI (2WD) vehicle. Deviations are documented separately!

Information on total installation time

The total installation time includes the time needed for mounting and demounting the vehicle-specific components, the heater specific installation time and all other times required for the system integration and initial start-up of the heater. The total installation time may vary for vehicle equipment other than provided.

Information on operating and installation instructions

1 Important information (not complete)

1.1 Installation and repair



The improper installation or repair of Webasto heating and cooling systems can cause fire or the leakage of deadly carbon monoxide, leading to serious injury or death.



To install and repair Webasto heating and cooling systems you need to have completed a special company training course and have the appropriate technical documentation, special tools and special equipment.



Installation and repair may ONLY be carried out by persons trained and certified in a Webasto training course. NEVER try to install or repair Webasto heating or cooling systems if you have not completed a Webasto training course, you do not have the necessary technical skills and you do not have the technical documentation, tools and equipment available to ensure that you can complete the installation and repair work properly.

Only use genuine Webasto parts. See the Webasto air and water heaters accessories catalogue for this purpose.

1.2 Operation

To ensure safe operation, we recommend having the heater checked every two years by an authorised Webasto dealer, especially when used over a long period and/or under extreme environmental conditions.

Do not operate the heater in closed rooms due to the danger of poisoning and suffocation.

Always switch off the heater before refuelling.

The heater may only be used with the prescribed fuel diesel (DIN EN 590) or petrol (DIN EN 228).

The heater may not be cleaned with a high-pressure cleaner.

1.3 Please note

ALWAYS follow all Webasto installation and operating instructions and observe all warnings.

To become familiar with and understand all functions and properties of the heater, the operating instructions must be read carefully and observed at all times.

For proper, safe installation and repair work, the installation instructions with all warnings and safety information must be carefully read and observed at all times. Please always contact a workshop authorised by Webasto for all installation and repair work.

Important

Webasto shall assume no liability for defects, damage and injuries resulting from a failure to observe the installation, repair and operating instructions of the information contained in them.

This liability exclusion particularly applies to improper installations and repairs, installations and repairs by untrained persons or in the case of a failure to use genuine spare parts.

The liability due to culpable disregard to life, limb or health and due to damage or injuries caused by a wilful or reckless breach of duty remain unaffected, as does the obligatory product liability.

Installation should be carried out according to the general, standard rules of technology. Unless specified otherwise, fasten hoses, lines and wiring harnesses to original vehicle lines and wiring harnesses using cable ties. Insulate loose wire ends and tie back. Connectors on electronic components must audibly snap into place during assembly.

Sharp edges should be fitted with rub protection. Spray unfinished body areas, e.g. drilled holes, with anti-corrosion wax (Tectyl 100K).

Observe the instructions and guidelines of the respective vehicle manufacturer for demounting and mounting vehicle specific components!

The initial start-up is to be executed with the Webasto Thermo Test Diagnosis.

When installing a programmable control module (e.g. a PWM Gateway), the corresponding settings must be checked or adjusted.

2 Statutory regulations governing installation

Guidelines	Thermo Top Evo
Heating Directive ECE R122	E1 00 0258
EMC Directive ECE R10	E1 04 5627

Note

The regulations of these guidelines are binding in the scope of the Directive 70/156/EEC and/or 2007/46/EC (for new vehicle models from 29/04/2009) and should also be observed in countries in which there are no special regulations.

Important

Failure to follow the installation instructions will result in the invalidation of the type approval for the heater and therefore invalidation of the general **homologation of the vehicle**.

Note

The heater is licensed in accordance with paragraph 19, section 3, No. 2b of the StVZO (German Road Traffic Licensing Authority).

2.1 Excerpt from ECE regulation 122 (heating system) paragraph 5 for the installation of the heater

Beginning of excerpt.

ANNEX VII

REQUIREMENTS FOR COMBUSTION HEATERS AND THEIR INSTALLATION

1. GENERAL REQUIREMENTS

1.7.1. A clearly visible tell-tale in the operator's field of view shall inform when the combustion heater is switched on or off.

2. VEHICLE INSTALLATION REQUIREMENTS

2.1. Scope

2.1.1. Subject to paragraph 2.1.2, combustion heaters shall be installed according to the requirements of this Annex.

2.1.2. Vehicles of category O having liquid fuel heaters are deemed to comply with the requirements of this Annex.

2.2. Positioning of heater

2.2.1. Body sections and any other components in the vicinity of the heater must be protected from excessive heat and the possibility of fuel or oil contamination.

2.2.2. The combustion heater shall not constitute a risk of fire, even in the case of overheating. This requirement shall be deemed to be fulfilled if the installation ensures an adequate distance to all parts and suitable ventilation, by the use of fire resistant materials or by the use of heat shields.

2.2.3. In the case of M2 and M3 vehicles, the heater must not be positioned in the passenger compartment. However, an installation in an effectively sealed envelope which also complies with the conditions in paragraph 2.2.2 may be used.

2.2.4. The label referred to in paragraph 1.4 or a duplicate, must be positioned so that it can be easily read when the heater is installed in the vehicle.

2.2.5. Every reasonable precaution should be taken in positioning the heater to minimise the risk of injury and damage to personal property.

2.3. Fuel supply

2.3.1. The fuel filler must not be situated in the passenger compartment and must be provided with an effective cap to prevent fuel spillage.

2.3.2. In the case of liquid fuel heaters, where a supply separate to that of the vehicle is provided, the type of fuel and its filler point must be clearly labelled.

2.3.3. A notice, indicating that the heater must be shut down before refuelling, must be affixed to the fuelling point. In addition a suitable instruction must be included in the manufacturer's operating manual.

2.4. Exhaust system

2.4.1. The exhaust outlet must be located so as to prevent emissions from entering the vehicle through ventilators, heated air inlets or opening windows.

2.5. Combustion air inlet

2.5.1. The air for the combustion chamber of the heater must not be drawn from the passenger compartment of the vehicle.

2.5.2. The air inlet must be so positioned or guarded that blocking by rubbish or luggage is unlikely.

2.6. Heating air inlet

2.6.1. The heating air supply may be fresh or recirculated air and must be drawn from a clean area not likely to be contaminated by exhaust fumes emitted either by the propulsion engine, the combustion heater or any other vehicle source.

2.6.2. The inlet duct must be protected by mesh or other suitable means.

2.7. Heating air outlet

2.7.1. Any ducting used to route the hot air through the vehicle must be so positioned or protected that no injury or damage could be caused if it were to be touched.

2.7.2. The air outlet must be so positioned or guarded that blocking by rubbish or luggage is unlikely.

End of excerpt.

In multilingual versions the German language is binding.

Information on validity

This installation documentation applies to VW / Skoda / petrol and diesel vehicles - for validity, see pages 1 to 4 - from model year 2013 and later, assuming technical modifications to the vehicle do not affect installation, any liability claims excluded. Depending on the vehicle version and equipment, modifications may be necessary during installation with respect to this installation documentation.

Vehicle and engine types, equipment variants and other specifications not listed in this installation documentation have not been tested. However, installation according to this installation documentation may be possible.

Technical information

Special tools

- Hose clamp pliers for auto-tightening hose clamps
- Hose clamp pliers for Clic hose clamps of type W
- Hose clamping pliers
- Automatic wire stripper, 0.2 - 6mm²
- Crimping pliers for male connector, 0.14 - 6mm²
- Crimping pliers for cable lug, 0.5 - 10mm²
- Crimping pliers for connector, 0.25 - 6mm²
- Torque wrench for 2.0 - 10 Nm
- Metric thread-setter kit
- Deep-hole marker
- Webasto Thermo Test Diagnosis with current software

Dimensions

- All dimensions are in mm.

Tightening torque values

- Tighten bolt connections in accordance with manufacturer's instructions or in accordance with state-of-the-art-technology.

Explanatory notes on document

You will find an identification mark on the outside top right corner of the page in question to provide you with a quick overview of the individual working steps.

Mechanics



Electrics



Coolant circuit



Combustion air

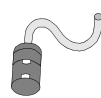

Fuel



Exhaust gas



Software



Special features are highlighted using the following symbols:

Specific risk of damage to components.



Specific risk due to electrical voltage.



Specific risk of fire or explosion.



Reference to a special technical feature.



The arrow in the vehicle icon indicates the position on the vehicle and the viewing angle.

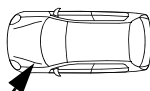

Reference to the manufacturer's vehicle-specific documents.



Reference to specific installation instructions of Webasto components (demonstrated with the example of the FuelFix).



Reference to general installation instructions of Webasto components.



Tightening torque according to the manufacturer's vehicle-specific documents.



Preliminary work for Golf VII / Golf VII Sportsvan

Vehicle



- Open the fuel tank cap.
- Ventilate the fuel tank.
- Close the fuel tank cap again.
- Depressurise the cooling system.
- Disconnect and remove the battery completely together with the carrier.
- Completely remove the air filter box together with the intake hose.
- Remove the engine underride protection.
- Remove the right underride protection.
- Remove the fuel tank underride protection, if present.
- Remove the right front wheel.
- Remove the front wheel well trim on the right.
- Remove the lateral instrument panel trim on the driver's side (in case of Telestart).
- Remove the A-pillar trim on the driver's side (in case of Telestart).
- Remove the footwell trim on the right and the left.
- Remove the lateral instrument panel trim on the front passenger's side (in case of ThermoCall for Golf VII).
- Remove the lower and upper A-pillar trim on the front passenger's side (in case of ThermoCall, Golf VII).
- Remove the rear bench seat (in case of Golf VII).
- Remove the right rear seat (in case of Sportsvan).
- Open the tank fitting service lid on the right.



Heater

- Remove years that do not apply from the type and duplicate label.
- Attach the duplicate label (type label) visibly in the appropriate place in the engine compartment.



Preliminary work for Passat

Vehicle



- Open the fuel tank cap.
- Ventilate the fuel tank.
- Close the fuel tank cap again.
- Depressurise the cooling system.
- Disconnect and remove the battery completely together with the carrier.
- Remove the air filter completely, together with the intake hose.
- Remove the engine underride protection.
- Remove the right underride protection.
- Remove the fuel tank underride protection, if present.
- Remove the right front wheel.
- Remove the front wheel well trim on the right.
- Remove the storage compartment.
- Remove the lateral instrument panel trim on the driver's side.
- Remove the A-pillar trim on the driver's side (in case of Telestart).
- Remove the footwell trim on the front passenger's side.
- Remove the rear bench seat.
- Open the tank fitting service lid on the right.



Heater

- Remove years that do not apply from the type and duplicate label.
- Attach the duplicate label (type label) visibly in the appropriate place in the engine compartment.



Preliminary work for Superb

Vehicle



- Open the fuel tank cap.
- Ventilate the fuel tank.
- Close the fuel tank cap again.
- Depressurise the cooling system.
- Disconnect and remove the battery completely together with the carrier.
- Remove the air filter completely, together with the intake hose.
- Remove the engine underride protection.
- Remove the right underride protection.
- Remove the fuel tank underride protection, if present.
- Remove the right front wheel.
- Remove the front wheel well trim on the right.
- Remove the storage compartment.
- Remove the lateral instrument panel trim on the driver's side (in case of Telestart).
- Remove the A-pillar trim on the driver's side (in case of Telestart).
- Remove the lower A-pillar trim on the driver's side (in case of Telestart from MY 2016).
- Remove the footwell trim on the front passenger's side.
- Remove the rear bench seat.
- Open the tank fitting service lid on the right.



Heater

- Remove years that do not apply from the type and duplicate label.
- Attach the duplicate label (type label) visibly in the appropriate place in the engine compartment.

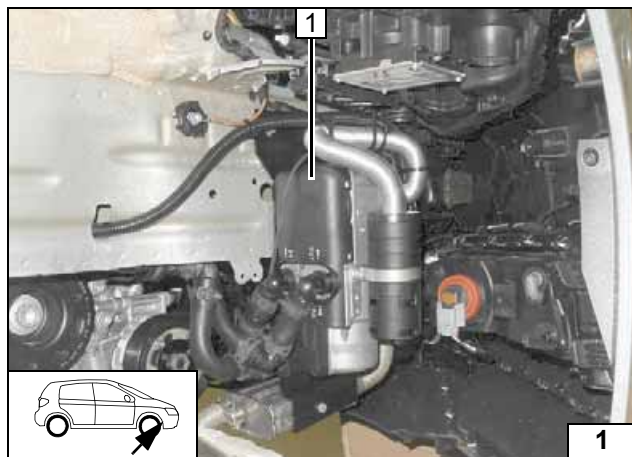

Heater assembly installation location

All vehicles

- 1 Heater assembly

Installation location

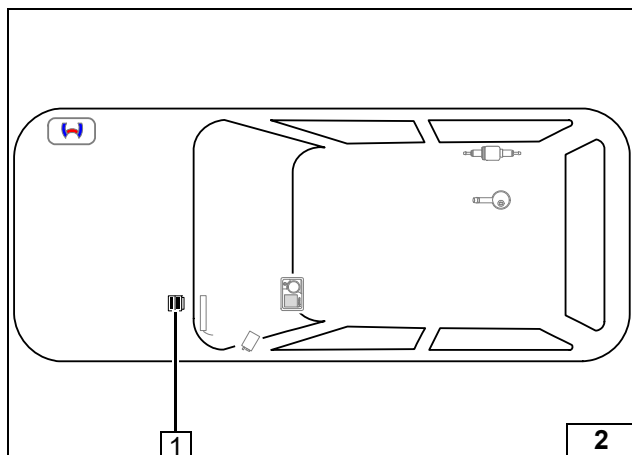

Preparing electrical system

- 1 Engine compartment fuse holder



Installation overview

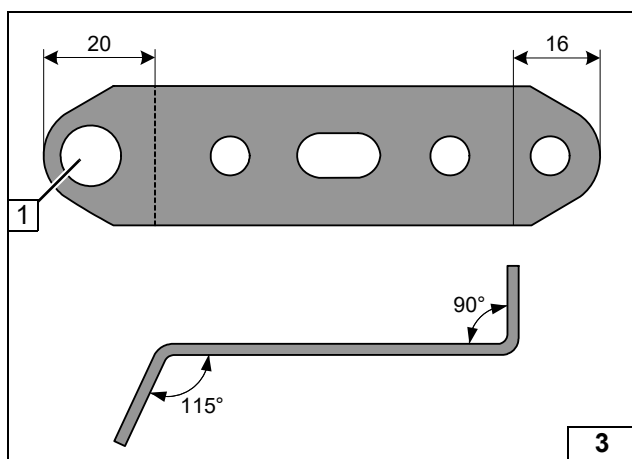

- 1 Drill out hole to $\text{Ø}12.5$

Preparing perforated bracket

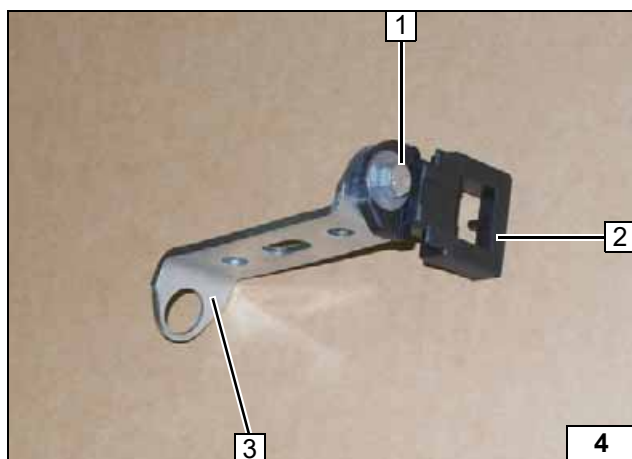

- 1 M5x16 bolt, washer [2x], nut
- 2 Fuse holder retaining plate
- 3 Perforated bracket

Premounting engine compartment fuse holder

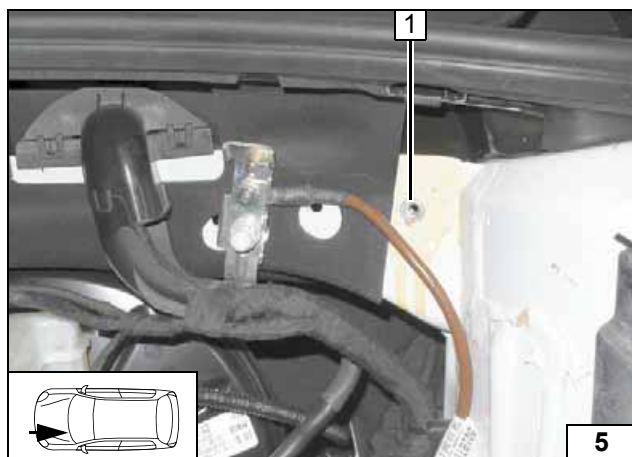

- 1 Drill out existing hole to $\text{Ø}9$, rivet nut

Installing rivet nut

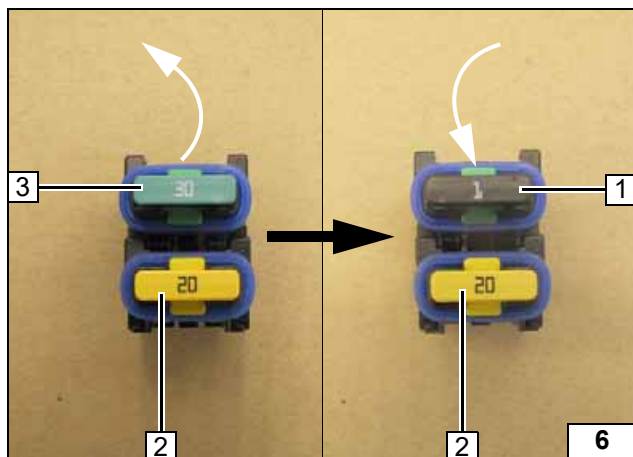

Replace passenger compartment 30A main fuse F2 **3** with 1A fuse **1**.

2 20A heater fuse F1



Preparing engine compartment fuses

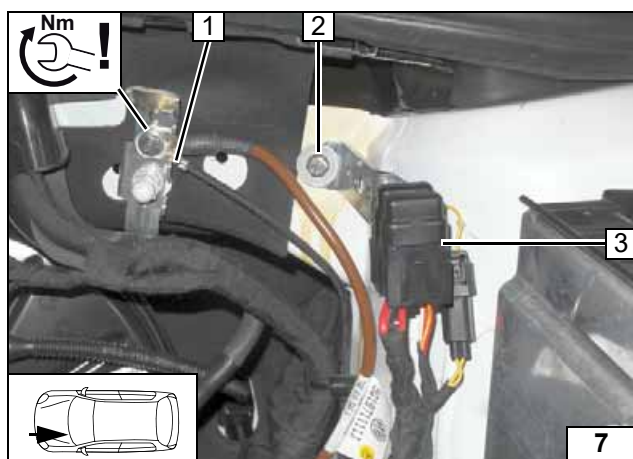

- 1** Earth wire on original vehicle earth point
- 2** M6x20 bolt, spring lock washer, large diameter washer
- 3** Fuses F1-2



Installing engine compartment fuse holder

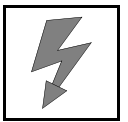

Electrical system



Wiring harness routing

Route heater wiring harness below the cover along the marking to the installation location of the heater and fasten using retaining clamp 1 [3x].

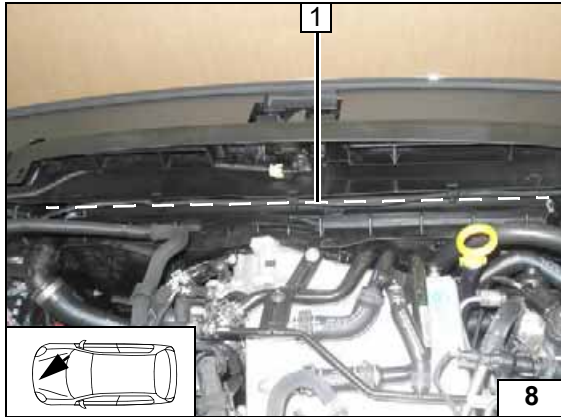

Positive wire for Golf VII / Golf VII Sportsvan

- 1 Positive wire on positive distributor
- 2 Wiring harnesses in original vehicle line duct

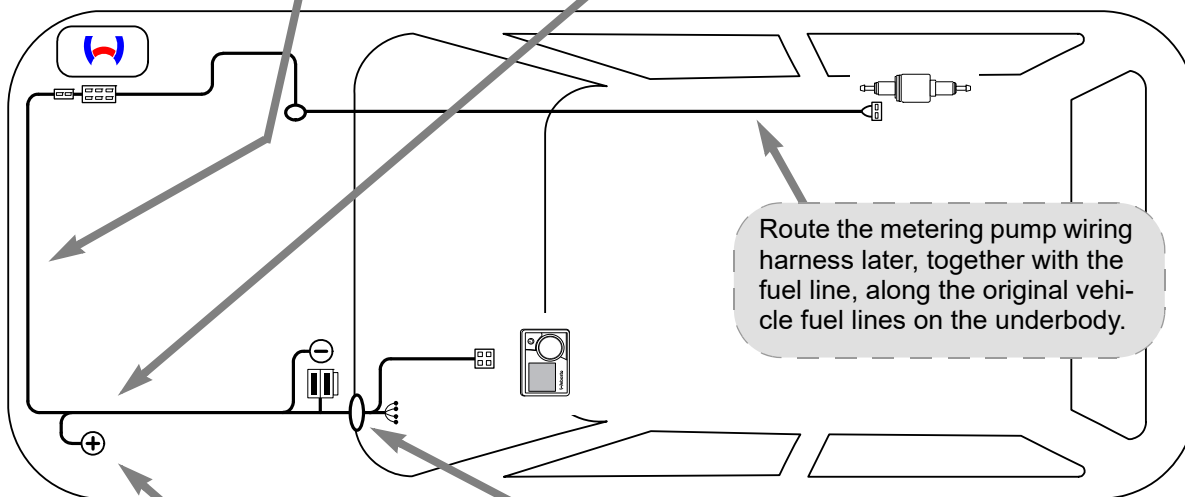
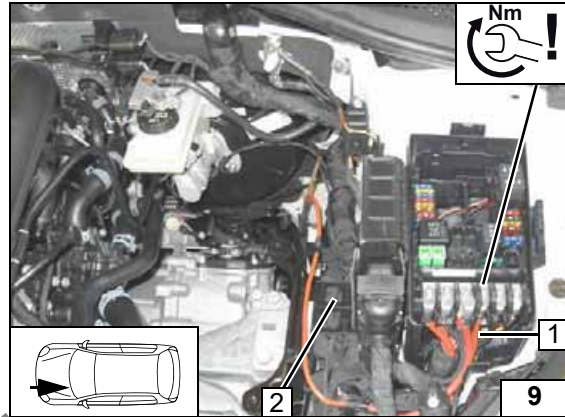

Wiring harness routing diagram

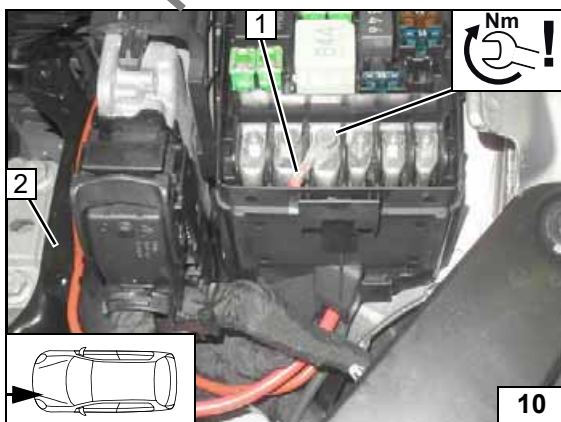

Positive wire for Passat / Superb

- 1 Positive wire on positive distributor
- 2 Wiring harnesses in original vehicle line duct

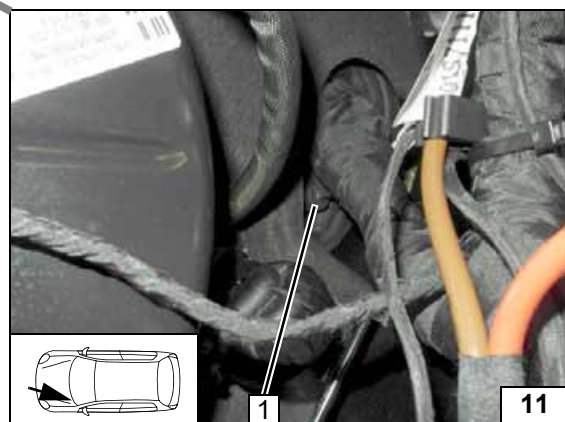

Wiring harness pass through

Route heater wiring harnesses and control element through protective rubber plug 1 to the passenger compartment.





Air-conditioning control

! Integrate the A/C control as explained in the separate installation documentation:

Installation documentation of **'Webasto Standard'** for A/C control of VW / Skoda / Seat MQB Climatic and Climatronic

or

Installation documentation **'Webasto Comfort'** for A/C control of VW / Skoda / Seat MQB Climatronic

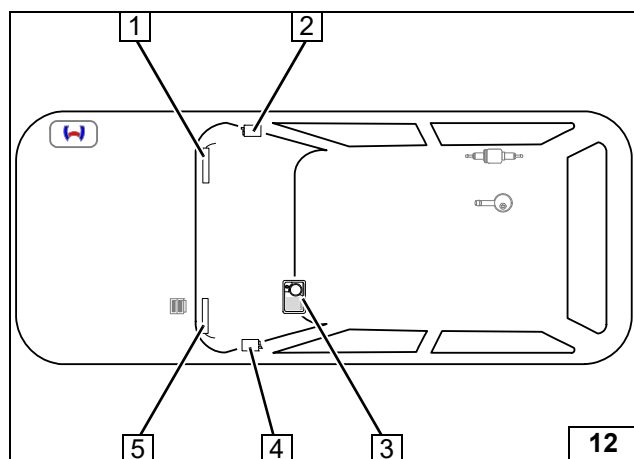

Control elements for Golf VII

- 1 ThermoCall aerial
- 2 ThermoCall receiver
- 3 MultiControl CAR
- 4 Telestart receiver
- 5 Telestart aerial

Installation overview

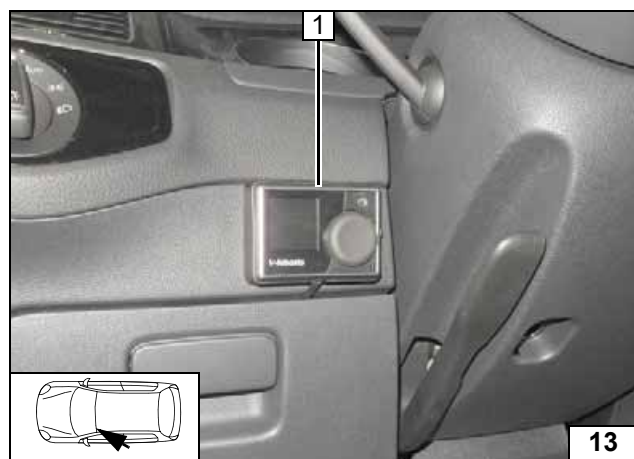

MultiControl CAR option

- 1 Installation frame



Installing MultiControl CAR

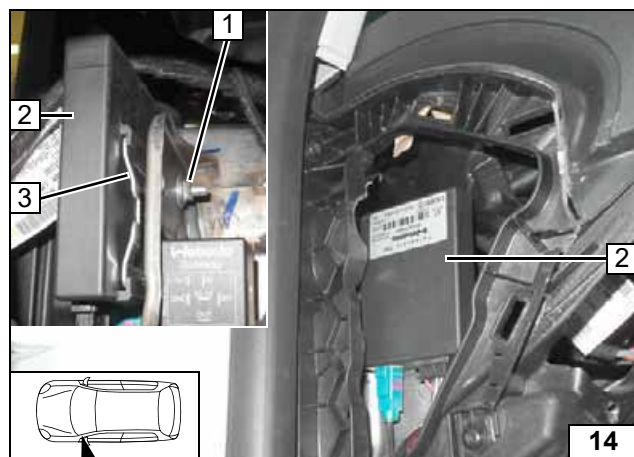

Remote option (Telestart)

- 1 M5x16 bolt, large diameter washer, nut, existing hole
- 2 Receiver
- 3 Bracket of receiver



Installing receiver

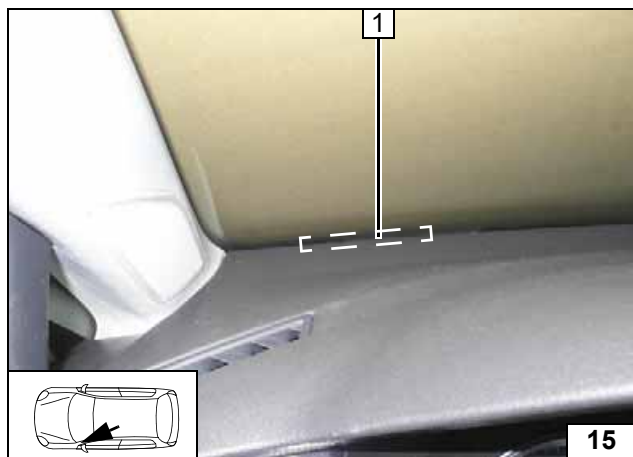

1 Aerial

Installing aerial

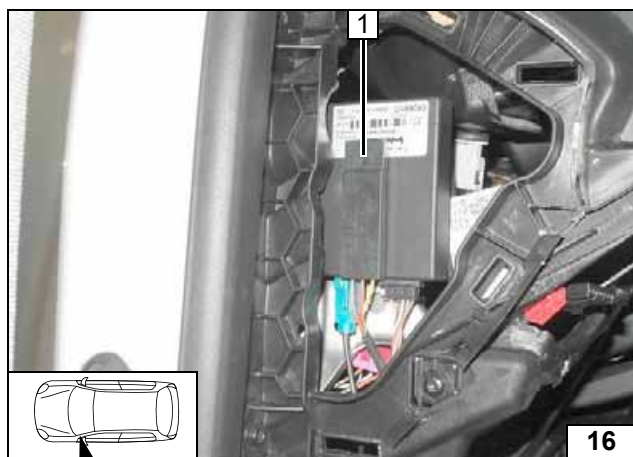

Temperature sensor T100 HTM

Fasten temperature sensor 1 with double-sided adhesive tape.



Installing temperature sensor



ThermoCall option

Fasten receiver 1 with double-sided adhesive tape.



Installing receiver

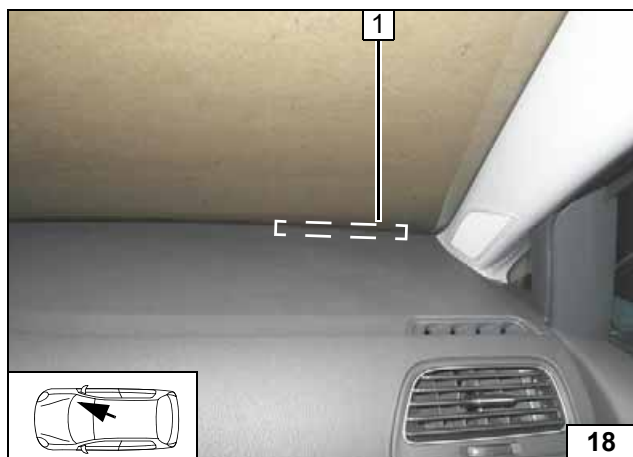

1 Aerial (optional)

Installing aerial

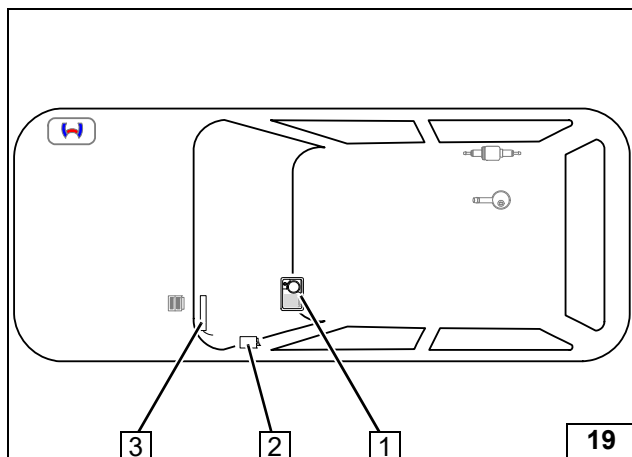

Control elements for Sportsvan

- 1 MultiControl CAR
- 2 Telestart / ThermoCall receiver
- 3 Telestart / ThermoCall aerial



Installation overview

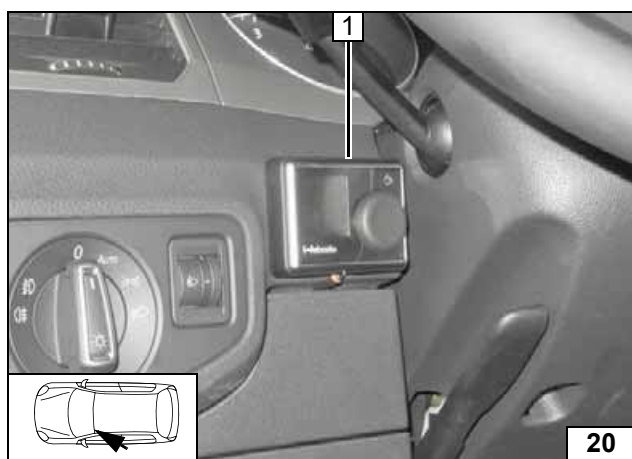

MultiControl CAR option

- 1 Installation frame



Installing MultiControl CAR

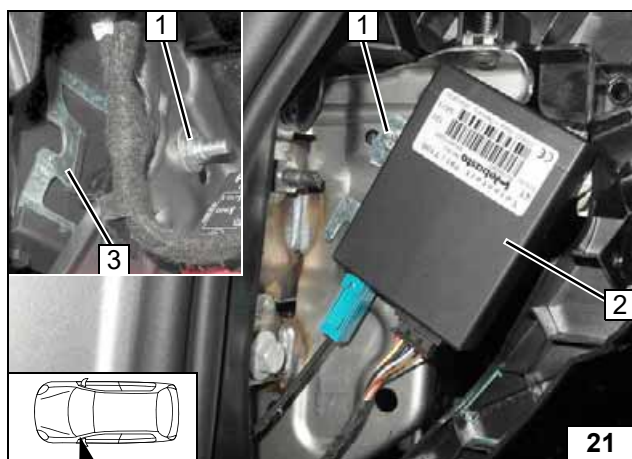

Remote option (Telestart)

- 1 M5x16 bolt, large diameter washer, nut, existing hole
- 2 Receiver
- 3 Bracket of receiver



Installing receiver

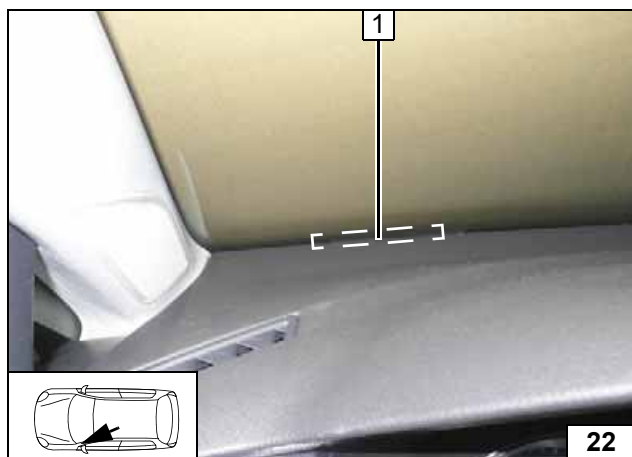

- 1 Aerial

Installing aerial

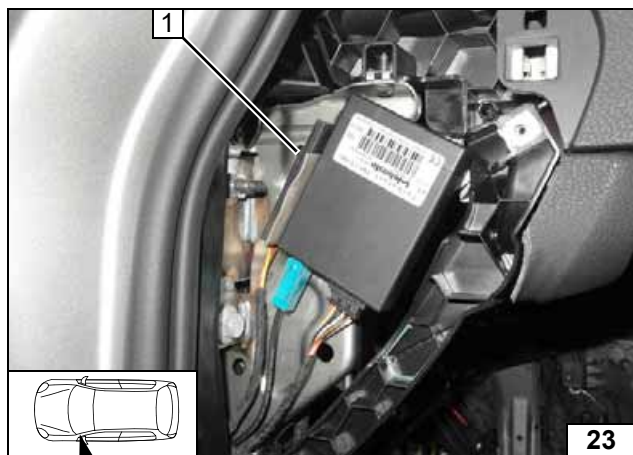

Temperature sensor T100 HTM

Fasten temperature sensor 1 with double-sided adhesive tape.



Installing temperature sensor

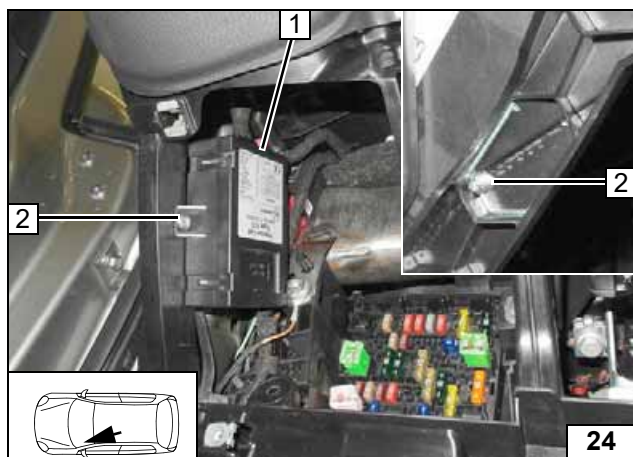

ThermoCall option

- 1 Receiver
- 2 Ø2.5 hole, 5.5x9.5 self-tapping screw



Installing receiver

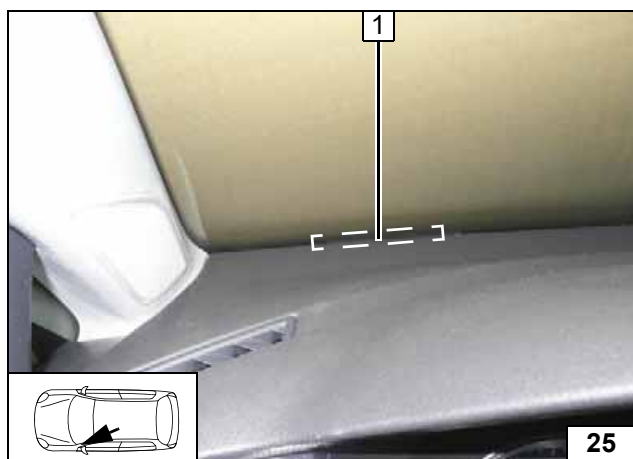

- 1 Aerial

Installing aerial

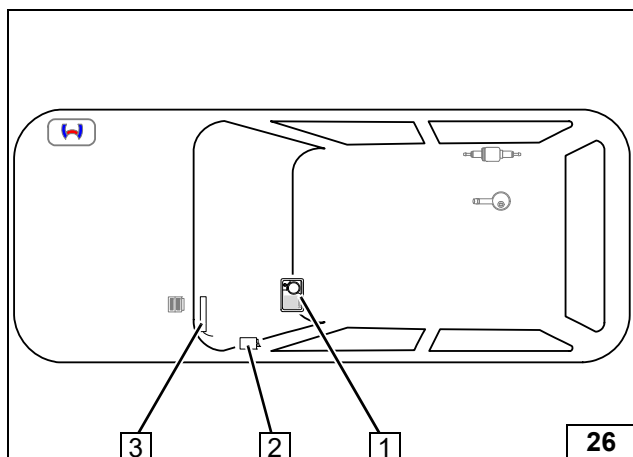

Control elements for Passat/ Superb

- 1 MultiControl CAR
- 2 Telestart / ThermoCall receiver
- 3 Telestart / ThermoCall aerial



Installation overview

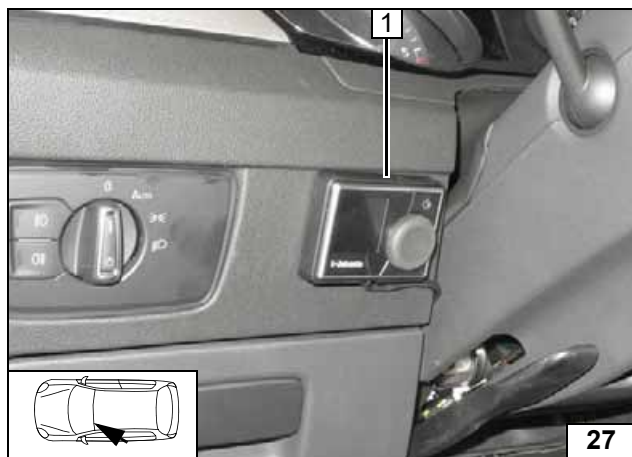

MultiControl CAR option

Passat

- 1 Installation frame



Installing MultiControl CAR

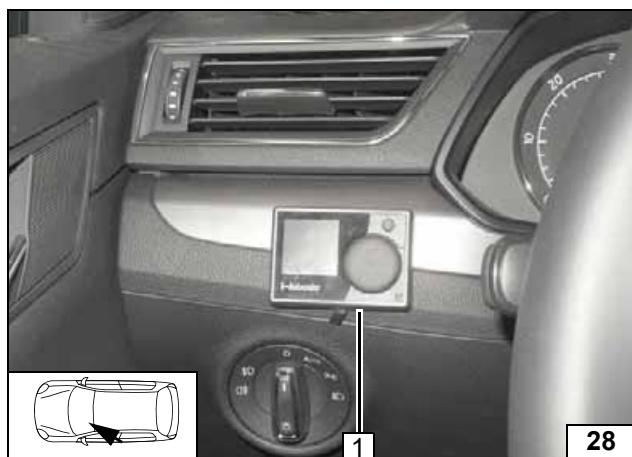

MultiControl CAR option

Superb

- 1 Installation frame



Installing Multi-Control CAR

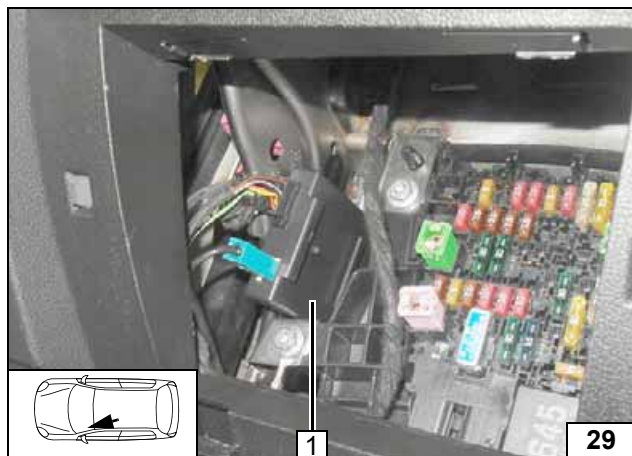

Remote option (Telestart)

Passat / Superb

Fasten receiver 1 with double-sided adhesive tape.



Installing receiver

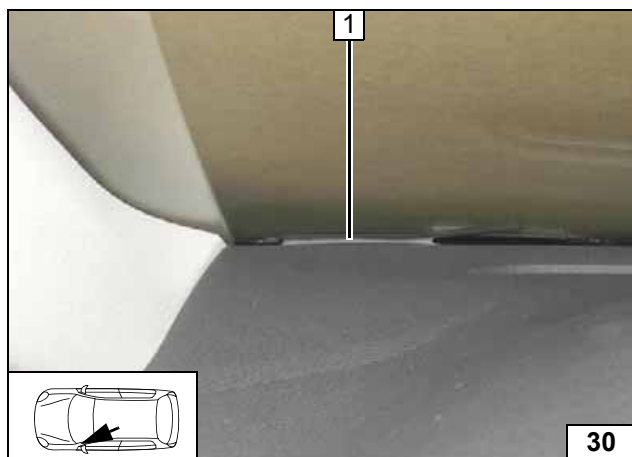

- 1 Aerial

Installing aerial

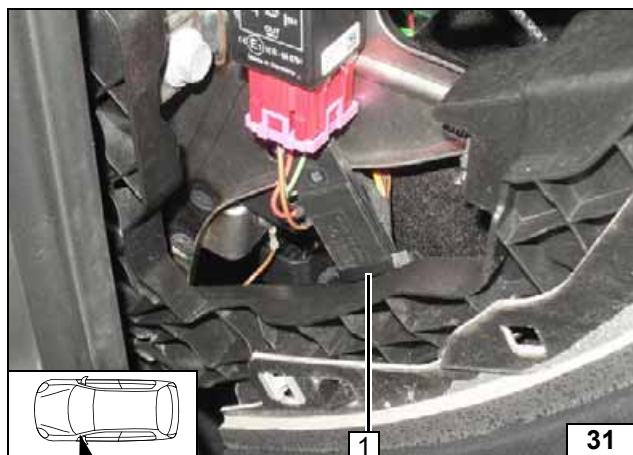

Temperature sensor T100 HTM

Fasten temperature sensor 1 with cable tie.



Installing temperature sensor

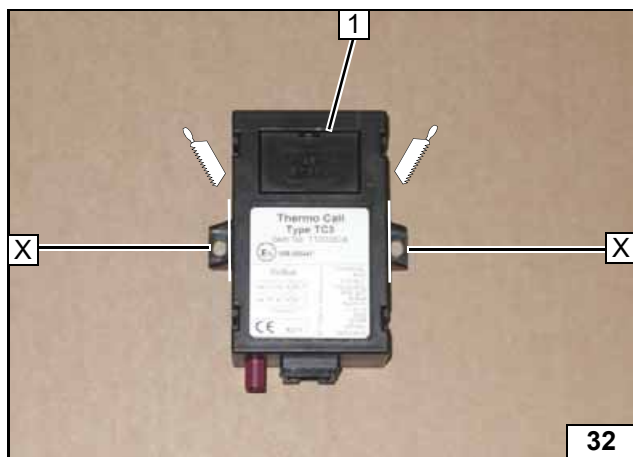

ThermoCall option

Passat / Superb

1 Receiver

X =



Removing lugs

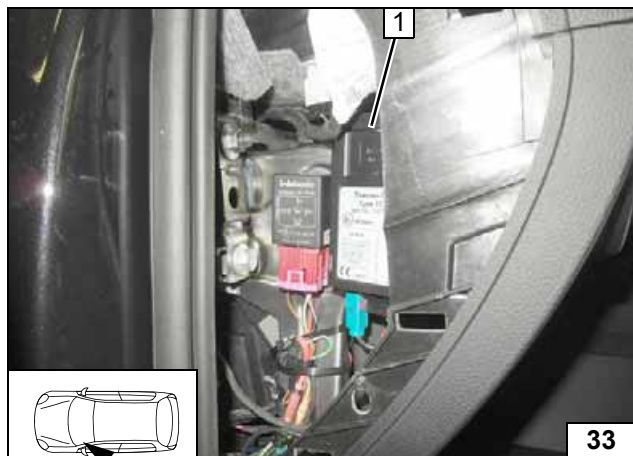

Fasten receiver 1 with double-sided adhesive tape.



Installing receiver

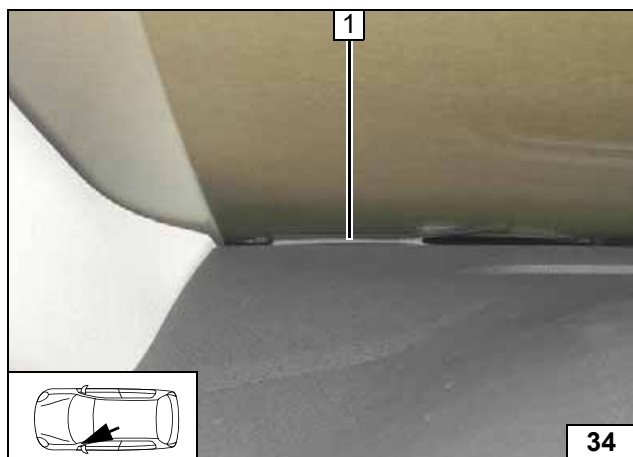

1 Aerial (optional)

Installing aerial

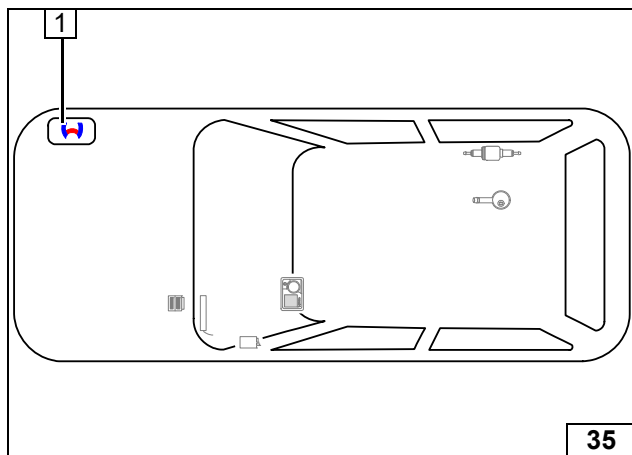

Preparing installation location

1 Heater assembly



Installation overview

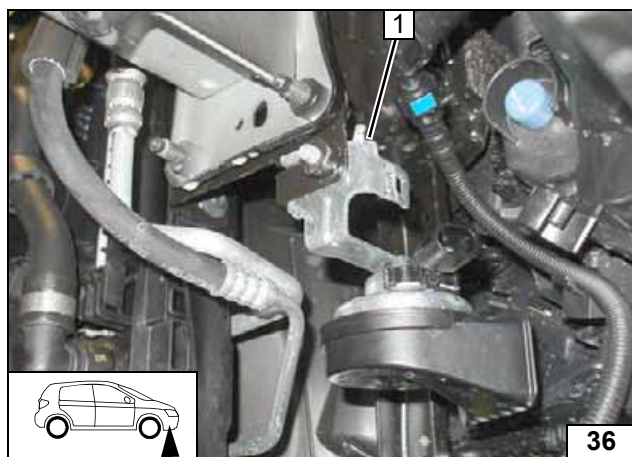

Angle down horn bracket 1 by 180° as shown.



Aligning horn bracket

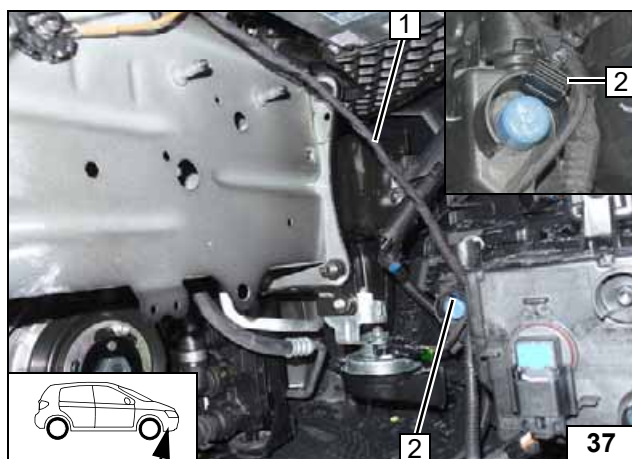

Golf VII / Golf VII Sportsvan

Disconnect original vehicle wiring harness 1, route as shown and secure using edge clip cable tie 2.



Aligning wiring harness



Passat / Superb

Detach retaining clip 1 with original vehicle wiring harness.



Aligning wiring harness

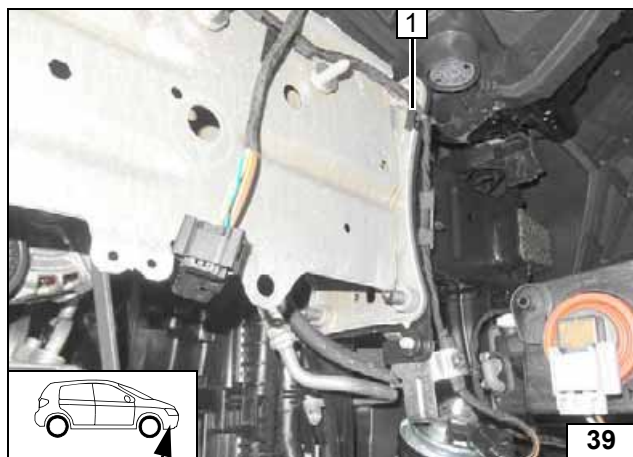

1 Edge clip cable tie

Fastening wiring harness

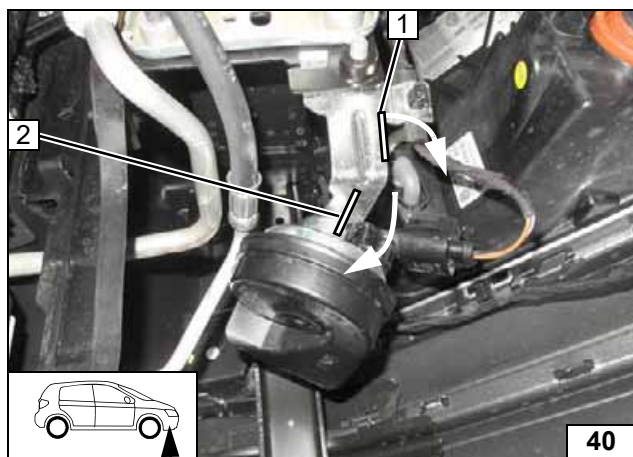

Passat

Angle down horn bracket at marking 1 by 90°.
Twist horn bracket at marking 2 by 20°.

Aligning horn bracket

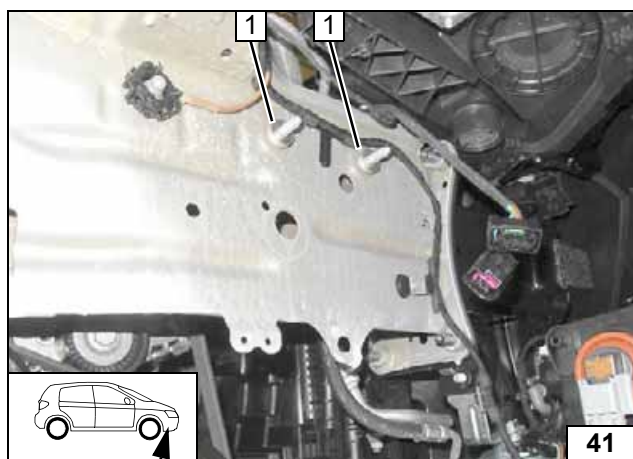

All vehicles

1 5 spacer on original vehicle stud bolt [2x]

Aligning wiring harness

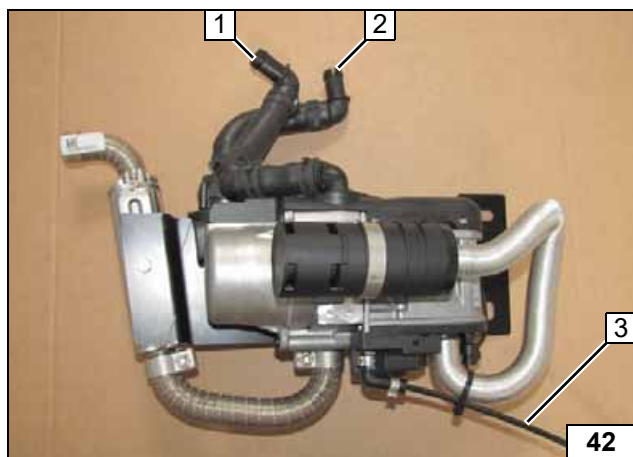

Installing heater assembly

1 Heater outlet connection
2 Heater inlet connection
3 Fuel line

Heater assembly

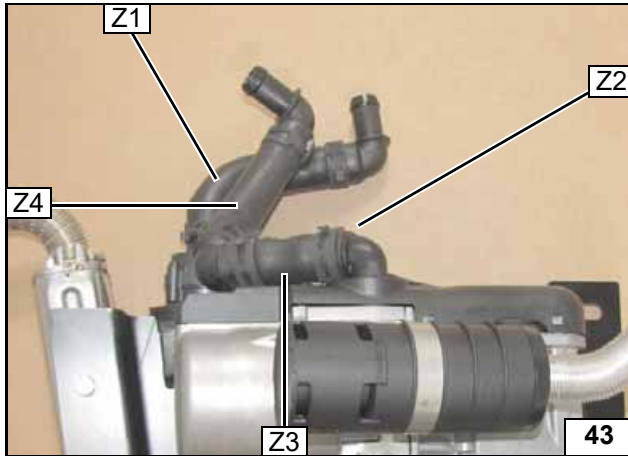
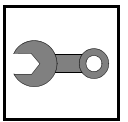

Petrol

- Z1** Hose section of circulating pump inlet
- Z2** Hose section of circulating pump outlet / heater inlet
- Z3** Hose section of heater outlet
- Z4** Hose section on hose **Z3** (heater outlet)



View of heater assembly hoses

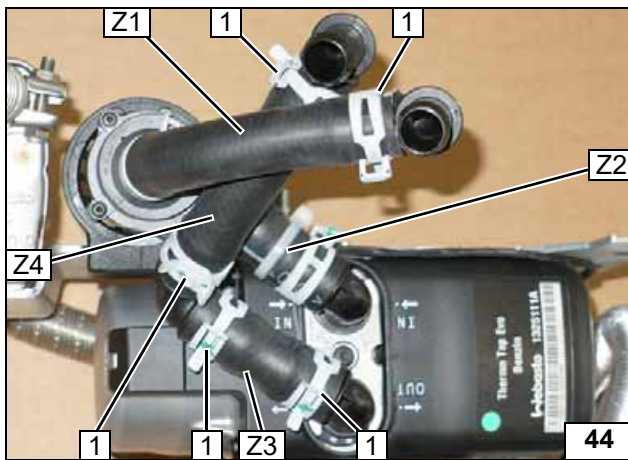

Diesel

Align spring clip **1** [5x] as shown.

- Z1** Hose section of circulating pump inlet
- Z2** Hose section of circulating pump outlet / heater inlet
- Z3** Hose section of heater outlet
- Z4** Hose section on hose **Z3** (heater outlet)



Aligning spring clips / view of heater assembly hoses

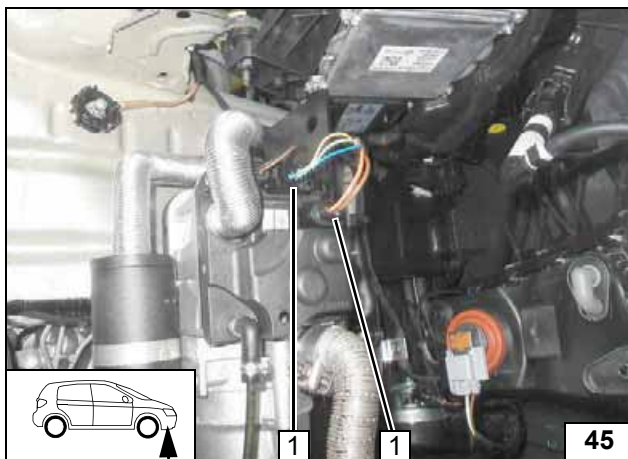

All vehicles

- 1** Heater wiring harness connector [2x]

Installing wiring harness

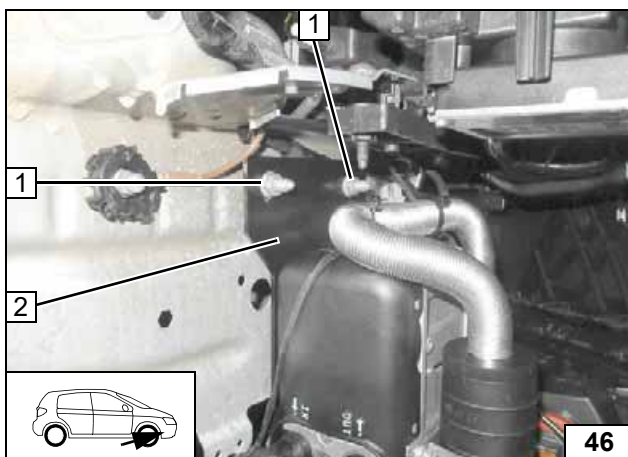

- 1** Mount original vehicle stud bolt, M8 flanged nut [2x each] loosely
- 2** Bracket

Installing heater

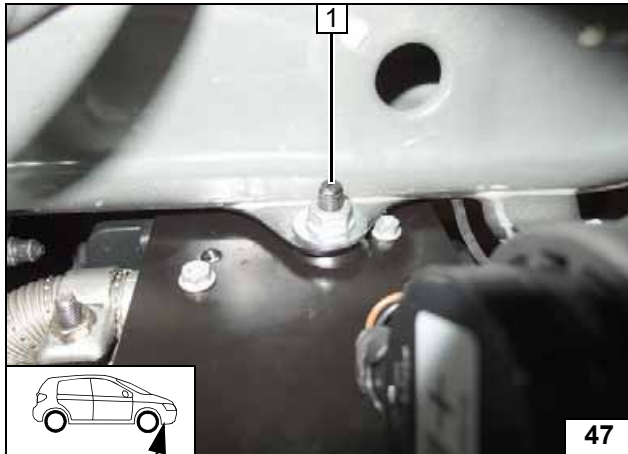
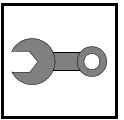

1 Stud bolt of bracket, large diameter washer, M8 flanged nut

Installing heater

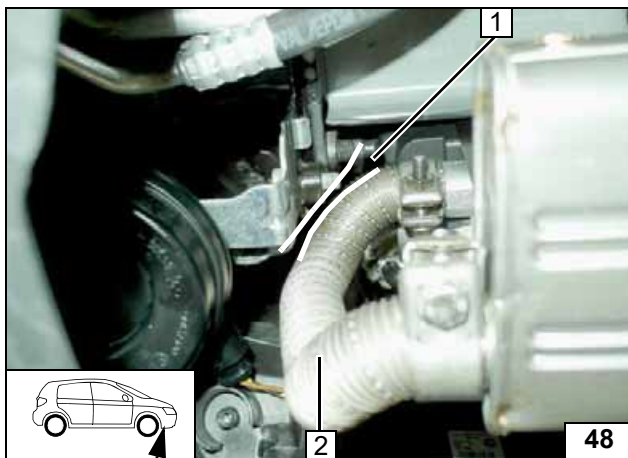

Ensure sufficient distance between exhaust pipe 2 and bolts of horn bracket at position 1, correct if necessary (see next figure).



$\geq 10 \text{ mm}$

Aligning exhaust pipe

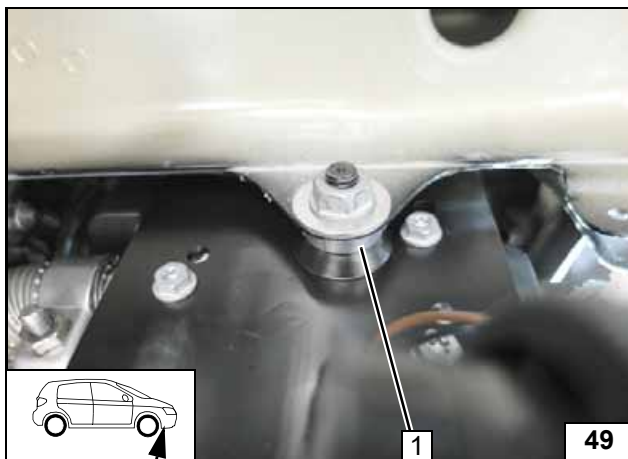

If the distance between exhaust pipe and bolts of horn bracket < 10 mm: add a 5 mm spacer at position 1!



Correcting distance

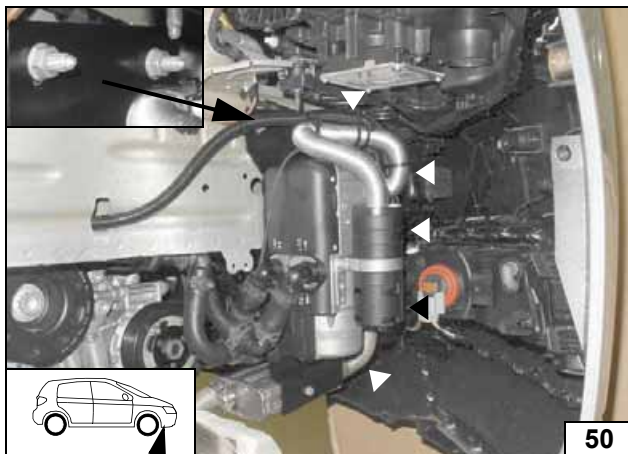

Tighten all screw connections. Ensure sufficient distance from neighbouring vehicle components, correct if necessary.



$\geq 10 \text{ mm}$

Checking distances

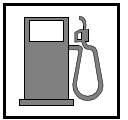

Fuel



Open the vehicle's fuel tank cap, ventilate the tank and then re-close the tank lock.

Catch any fuel running off in an appropriate container.

Route fuel line and metering pump wiring harness so that they are protected against stone impact. Unless specified otherwise, always fasten using cable ties.



Provide rub protection for fuel line and wiring harness in areas where there are sharp edges.

The fuel line and wiring harness are routed to the metering pump as shown in the wiring harness routing diagram.

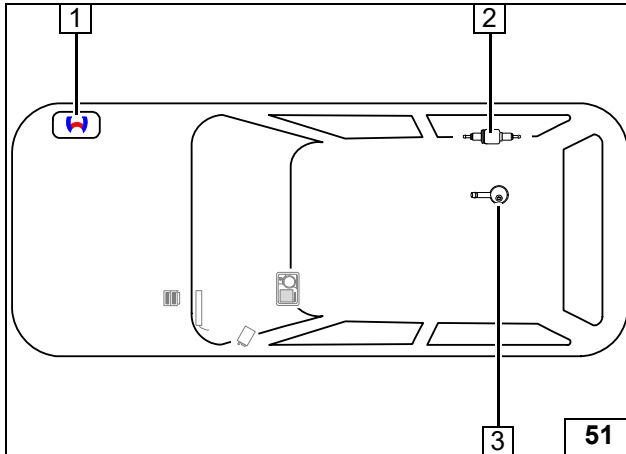

- 1 Heater assembly
- 2 Metering pump
- 3 FuelFix

51



Connector X7

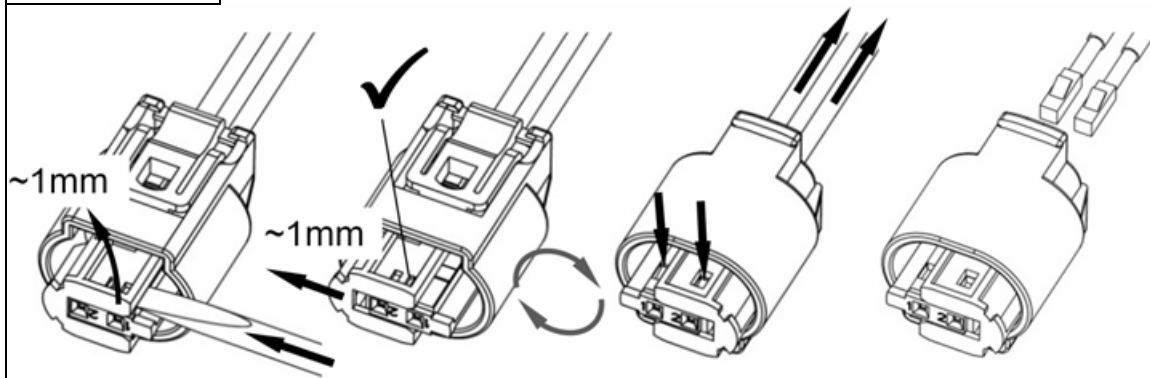

52

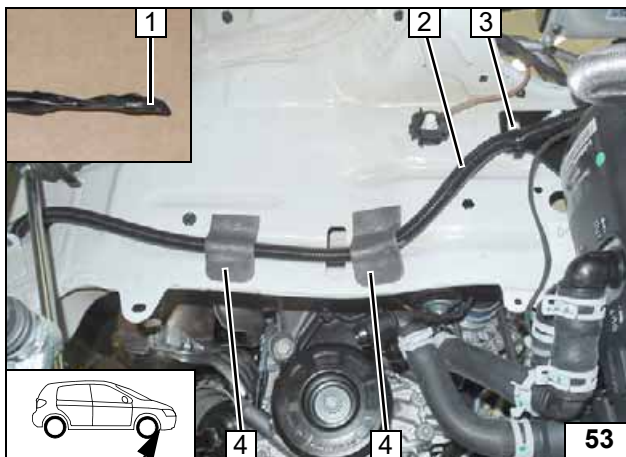

Close the opening of the fuel line 1 with insulating tape.

Draw fuel line and metering pump wiring harness in Ø10 corrugated tube (900 long) 2, route in wheel well as shown and secure using self-adhesive foam [2x] 4. Degrease beforehand bonding surfaces at position 4 [2x].

- 3 Cable tie

53



Installation overview

Dismantling metering pump connector



Routing lines

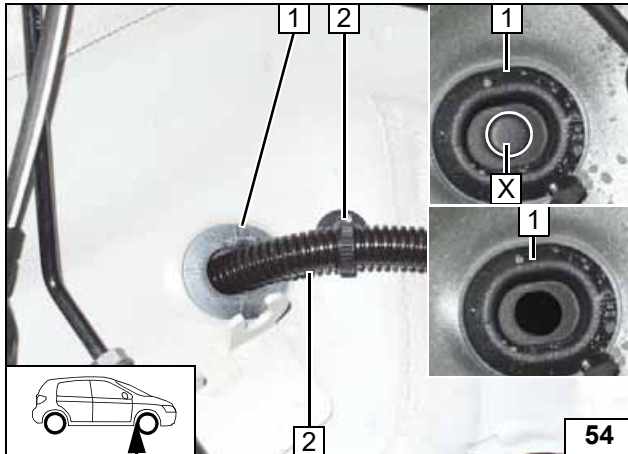

Open original vehicle pass through **1** as shown, insert corrugated tube with fuel line and metering pump wiring harness **3**.

2 Clip-type cable tie, original vehicle hole

X =



Routing corrugated tube through original vehicle pass through

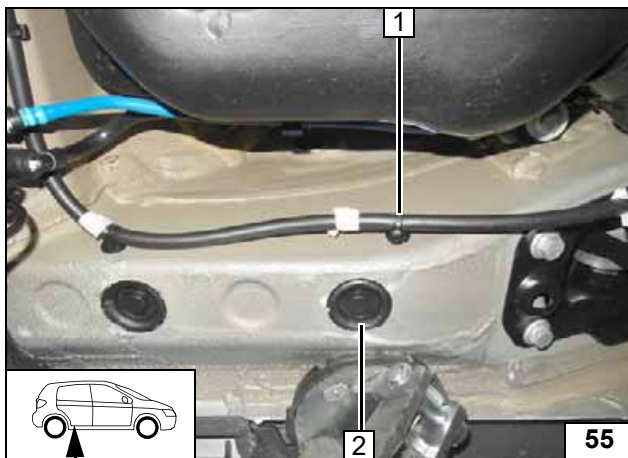

Version 1

- 1** Detach retaining clip from hole (if present)
- 2** Remove cover cap (will be remounted later)

Preparing installation location of metering pump

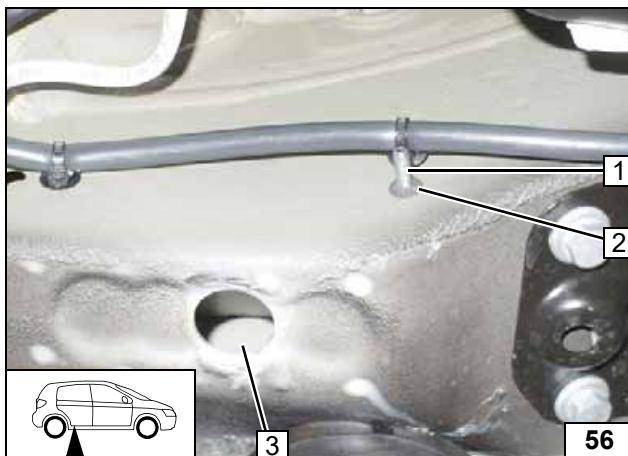

Insert M6x20 bolt **1** through opening **3** into hole.

2 Lock washer



Preparing installation location of metering pump

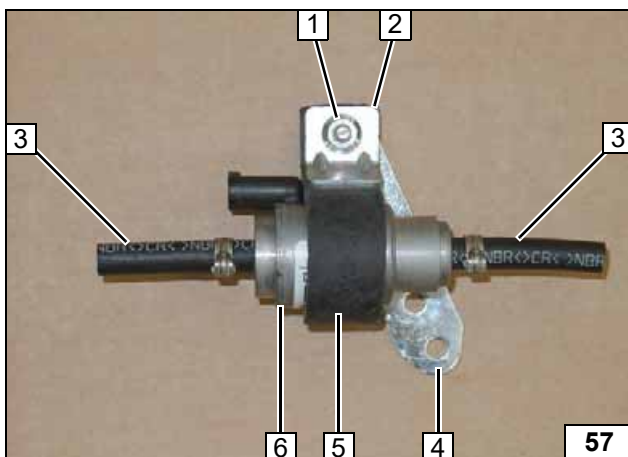

- 1** M6x25 bolt, flanged nut
- 2** Support angle bracket
- 3** Hose section, Ø10 clamp [2x each]
- 4** Perforated bracket
- 5** Metering pump mount
- 6** Metering pump

Premounting metering pump

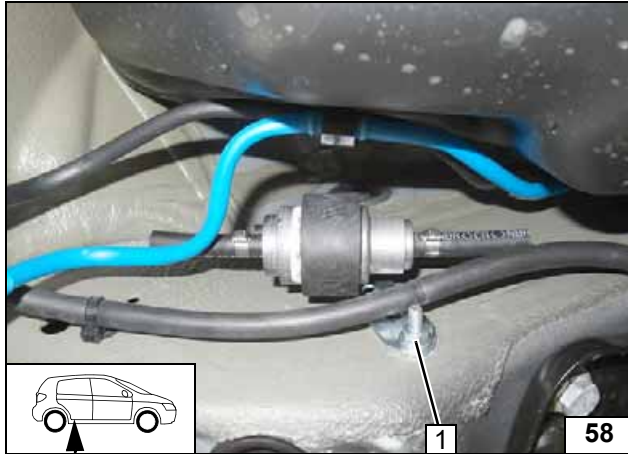

1 M6 flanged nut



Installing metering pump

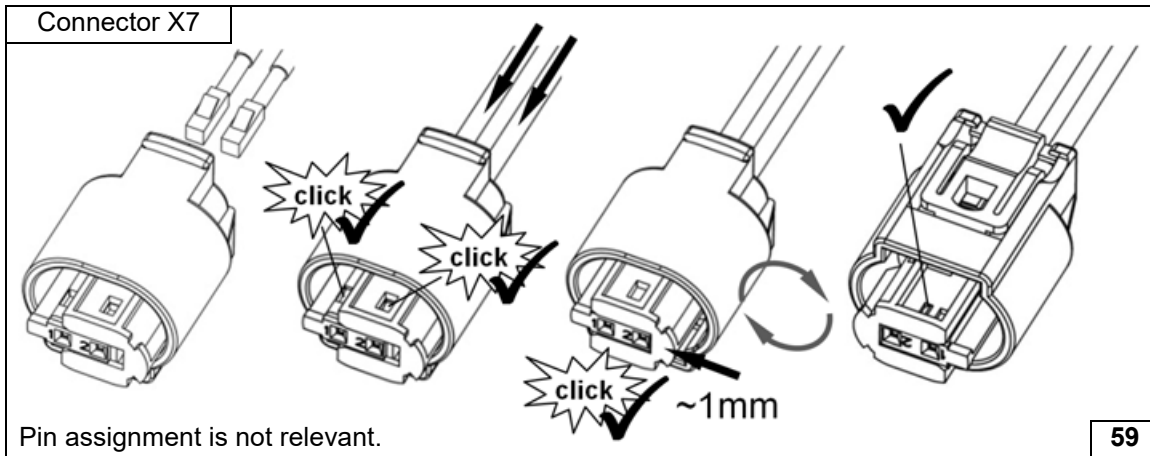

Completing metering pump connector

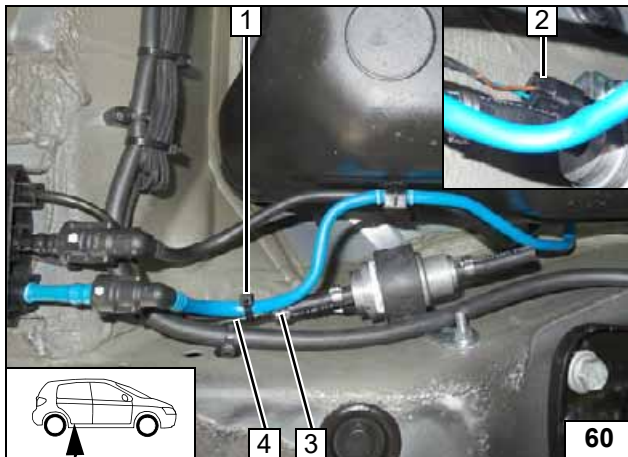

1 Cable tie
2 Metering pump wiring harness, connector X7 mounted
3 Ø10 clamp
4 Fuel line of heater



Connecting metering pump

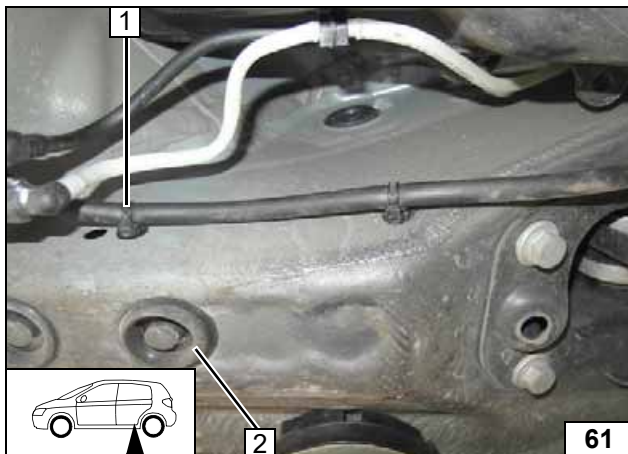

Version 2

1 Detach retaining clip from hole (if present)
2 Remove cover cap (will be remounted later)

Preparing installation location of metering pump

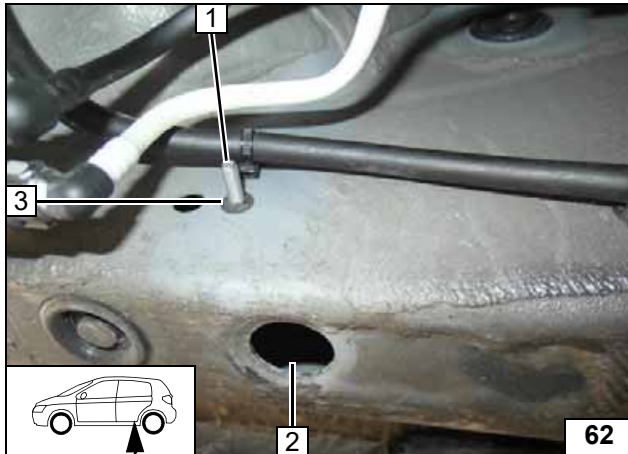
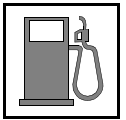

Insert M6x20 bolt 1 through opening 2 into hole.



3 Lock washer

Preparing installation location of metering pump

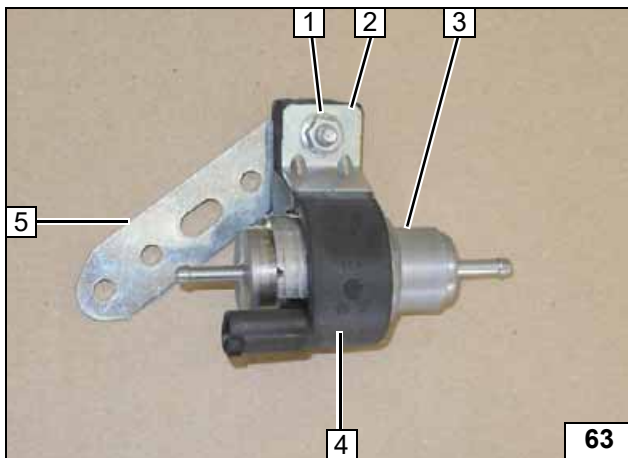

- 1 M6x25 bolt, flanged nut
- 2 Support angle bracket
- 3 Metering pump
- 4 Metering pump mount
- 5 Perforated bracket

Premounting metering pump

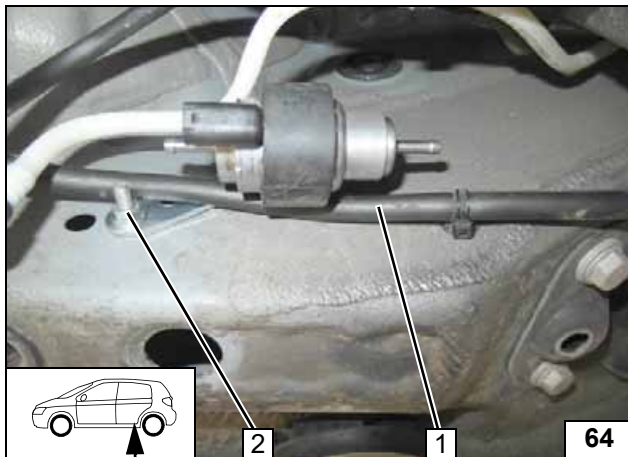

Route original vehicle wiring harness 1 as shown.



2 M6 flanged nut

Installing metering pump

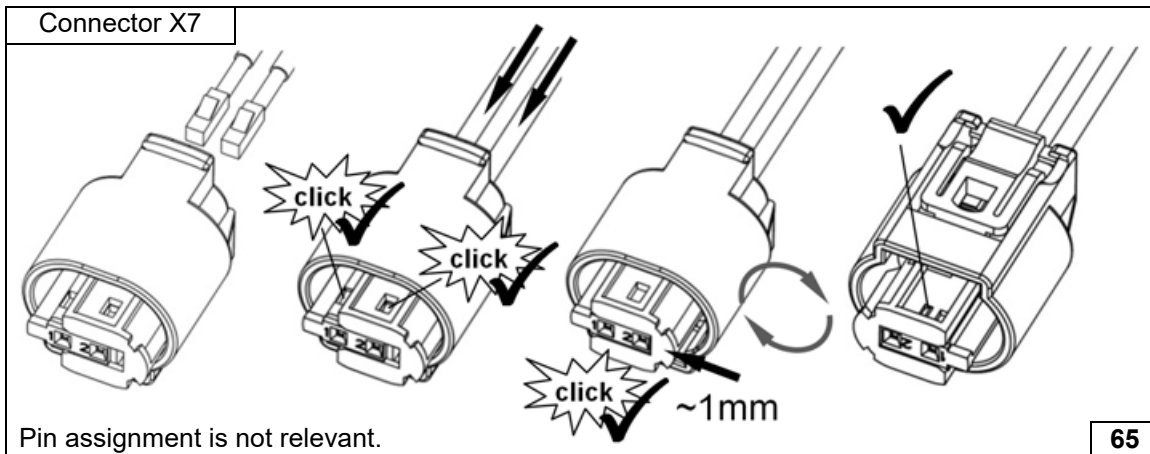

Pin assignment is not relevant.

Completing metering pump connector

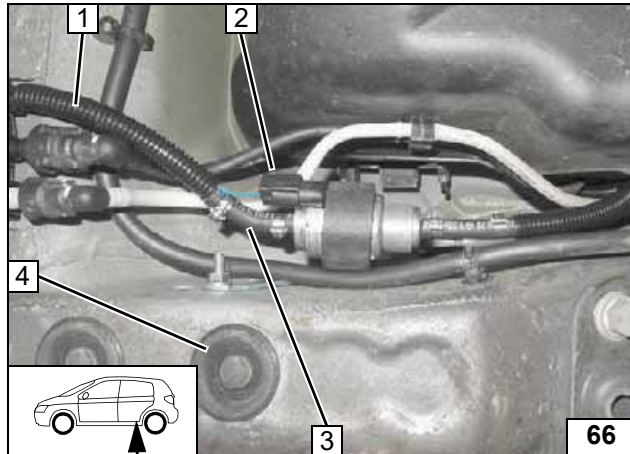
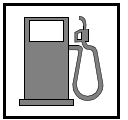

Cut Ø10 corrugated tube to length by 130mm. Draw fuel line and metering pump wiring harness into 130 corrugated tube 1.

- 2 Metering pump wiring harness, connector X7 mounted
- 3 Fuel line of heater, hose section, Ø10 clamp [2x]
- 4 Cover cap inserted



Connect-
ing meter-
ing pump

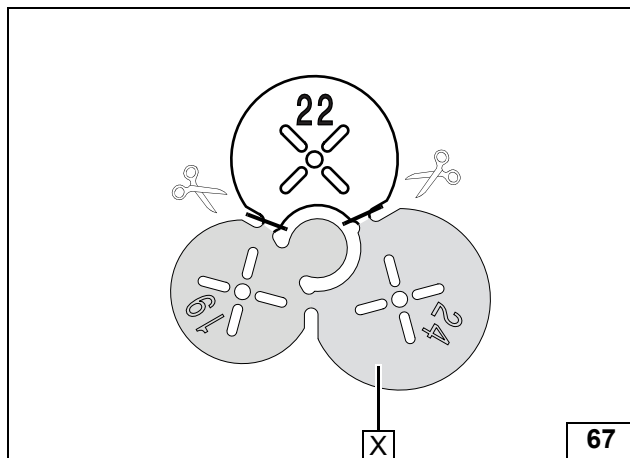

FuelFix installation for TSI

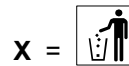

Preparing
drilling tem-
plate

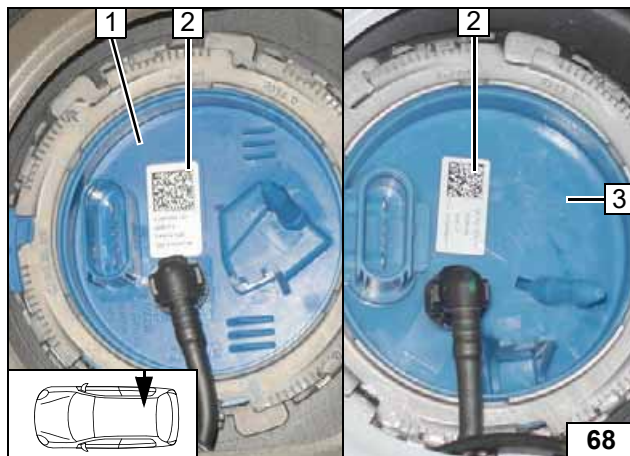

Work step F1.

Remove sticker 2, will finally be fixed on again in a new position.

- 1 Tank fitting version 1
- 3 Tank fitting version 2



Moving
sticker

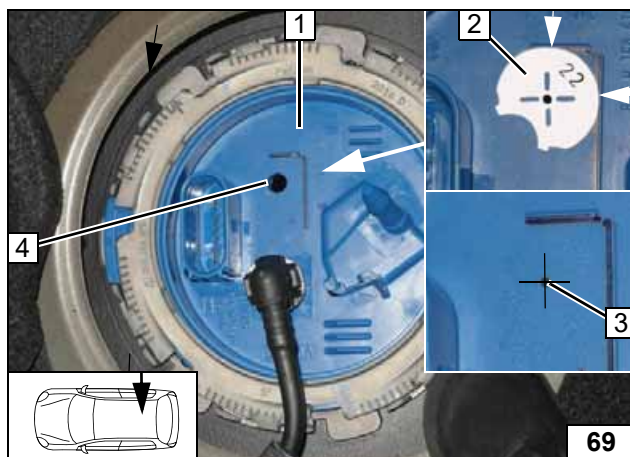

Next work steps are shown on a tank fitting version 1.
Work steps F2 and F3.

- 1 Tank fitting version 1
- 2 Position template with outer Ø d_a = 22 at the markings.
- 3 Hole pattern
- 4 Hole made with provided drill



Copying
hole pat-
tern, drill-
ing hole

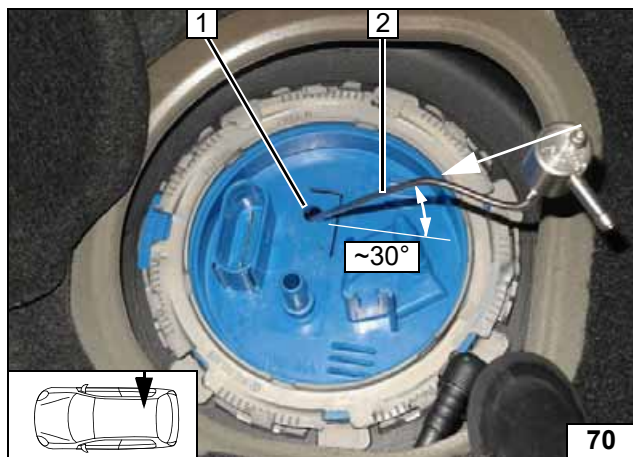

Work steps F4 and F5.

Bend FuelFix 2 according to template and cut to length. Insert into hole 1.



Inserting FuelFix

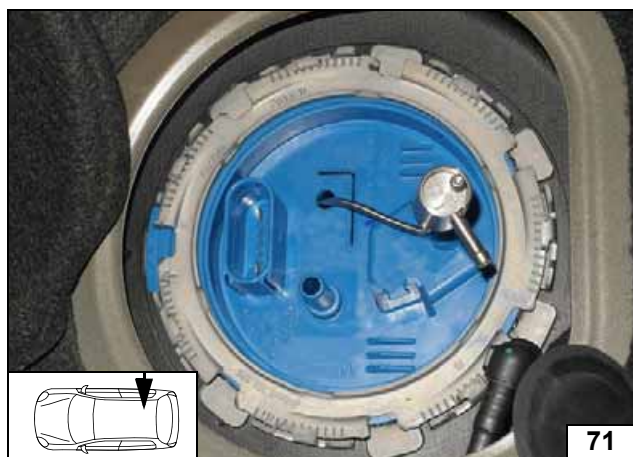

Work step F5.

Inserting FuelFix



Inserting FuelFix

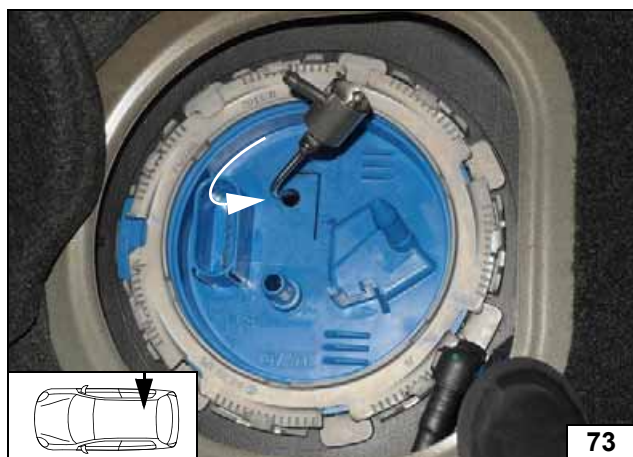

Inserting FuelFix

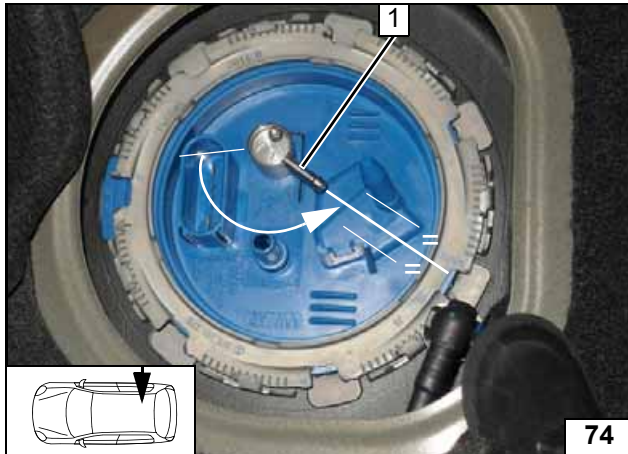

Work steps F5.3 and F5.4.

Align FuelFix 1 as shown.



Inserting FuelFix

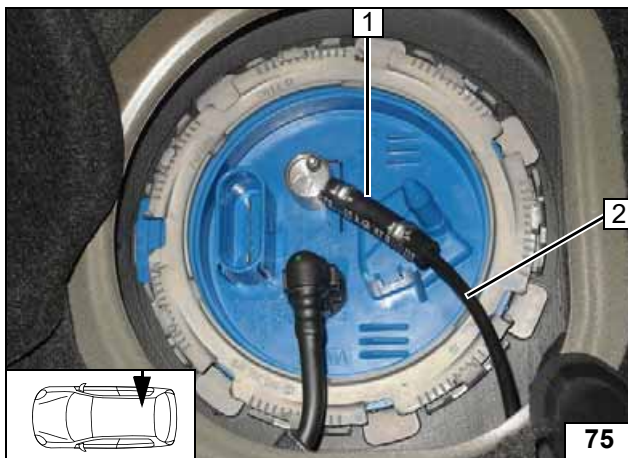

Work step F6.

- 1 Hose section, Ø10 clamp [2x]
- 2 Fuel line

Connecting fuel line

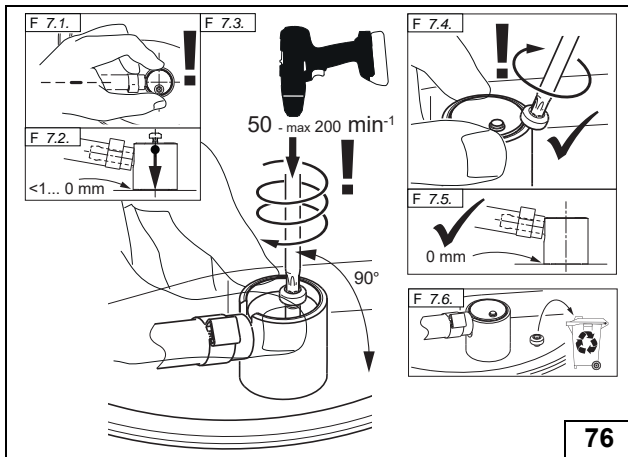

Work step F7.



Installing FuelFix



Work step F8.

Ensuring firm seating of FuelFix

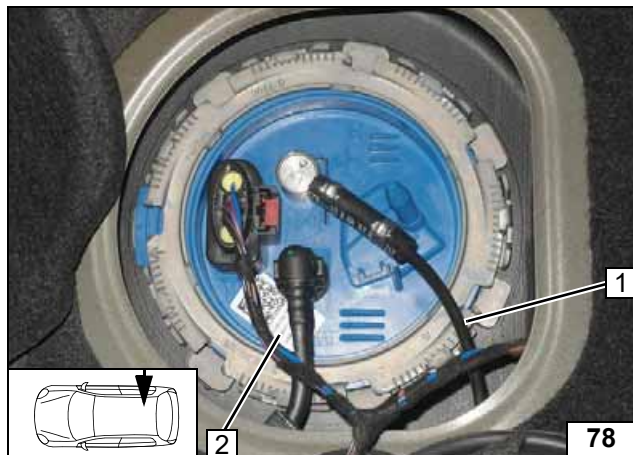

Attach fuel line 1 for tension relief at an appropriate point.

2 Moving sticker



Securing fuel line

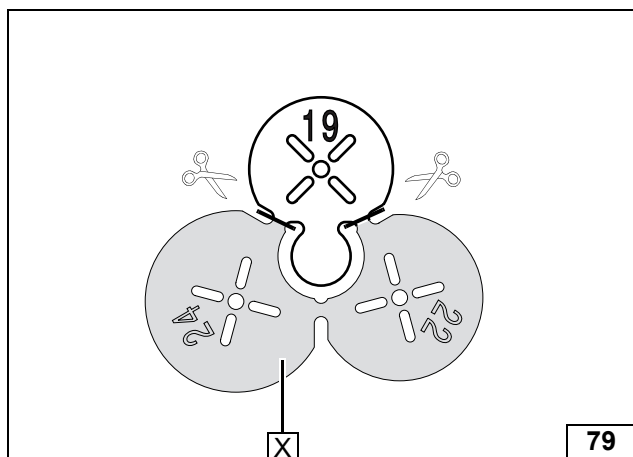

Installing FuelFix for Golf VII / Golf VII Sportsvan TDI

X =

Preparing drilling template

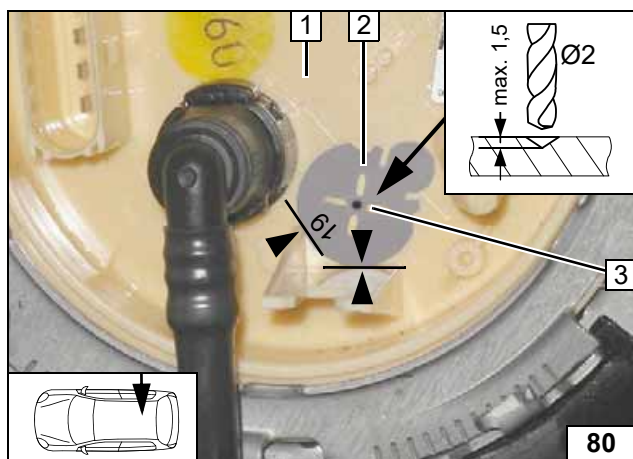

Work steps F1 and F2.

- 1 Tank fitting
- 2 Position Ø19 drilling template as shown
- 3 Ø2 centring hole



Copying hole pattern

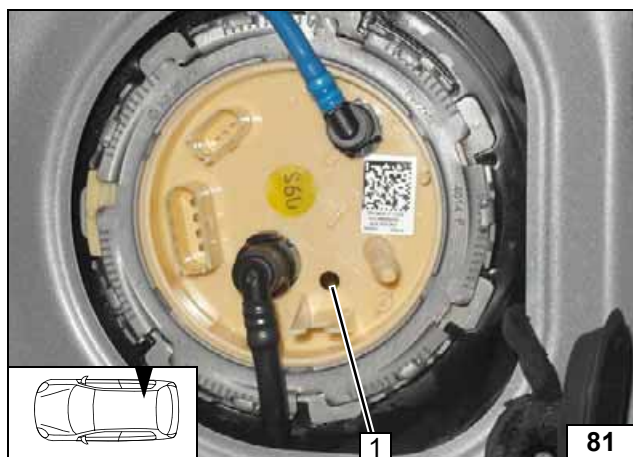

Work step F3.

- 1 Hole made with provided drill

Hole for FuelFix

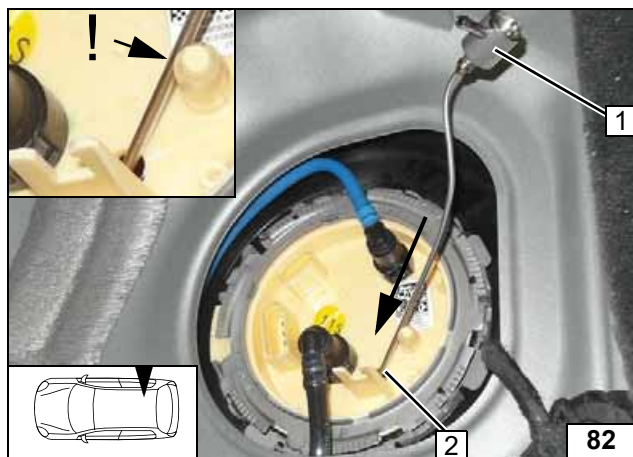
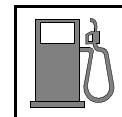

Work steps F4 and F5.

Bend FuelFix 1 according to template and cut to length. Insert into hole 2.



Inserting FuelFix



Work step F5.

Inserting FuelFix

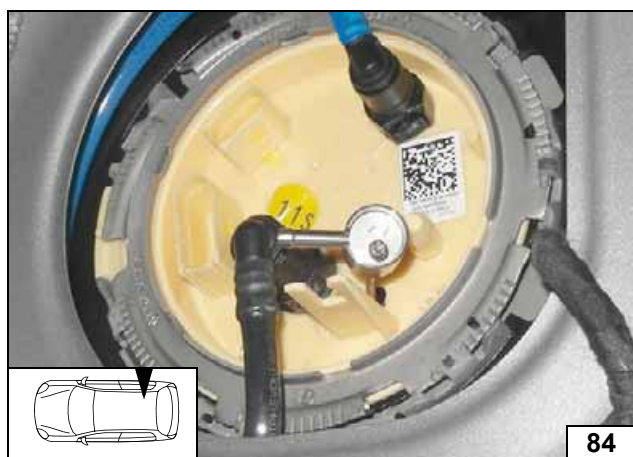

Inserting FuelFix

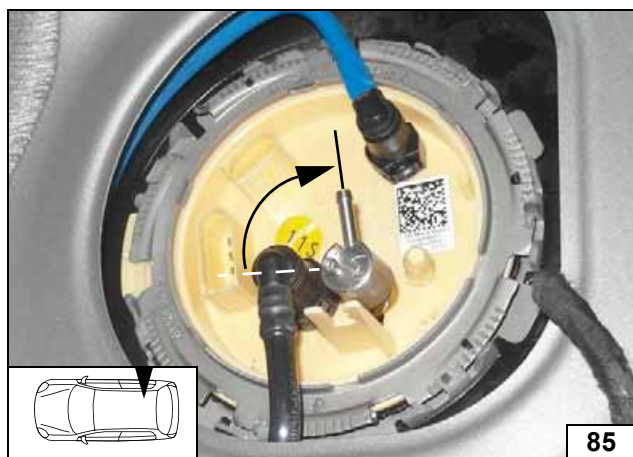

Inserting FuelFix

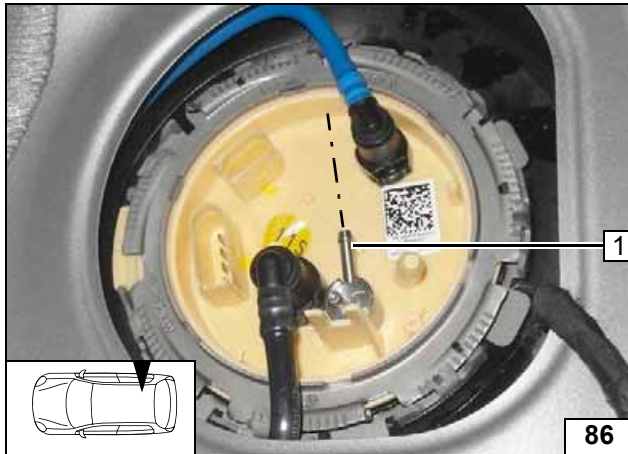
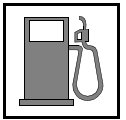

Work steps F5.3 and F5.4.

Align FuelFix 1 as shown.



Aligning FuelFix

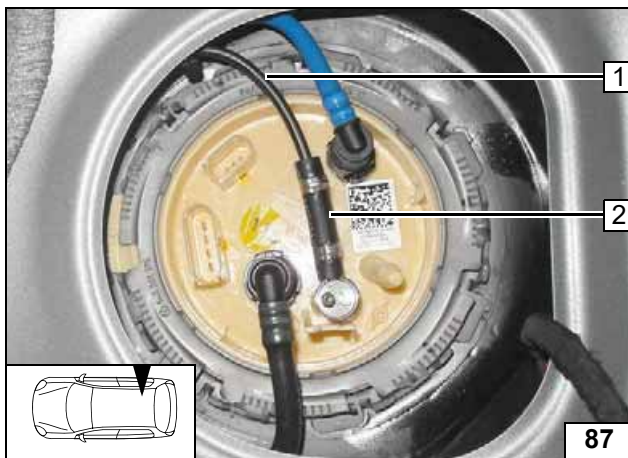

Work step F6.

- 1 Fuel line
- 2 Hose section, Ø10 clamp [2x]

Connecting fuel line

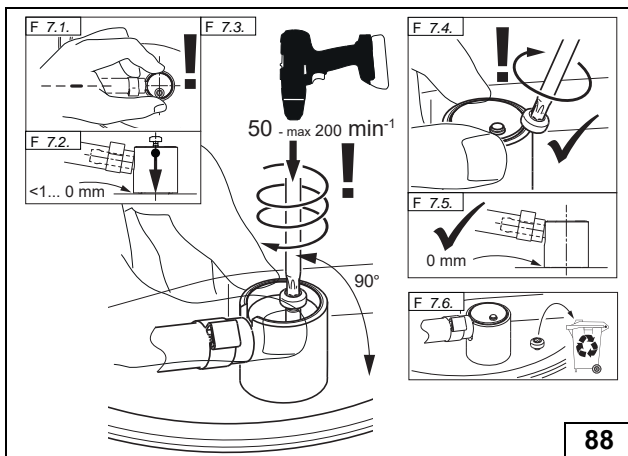

Work step F7.



Installing FuelFix

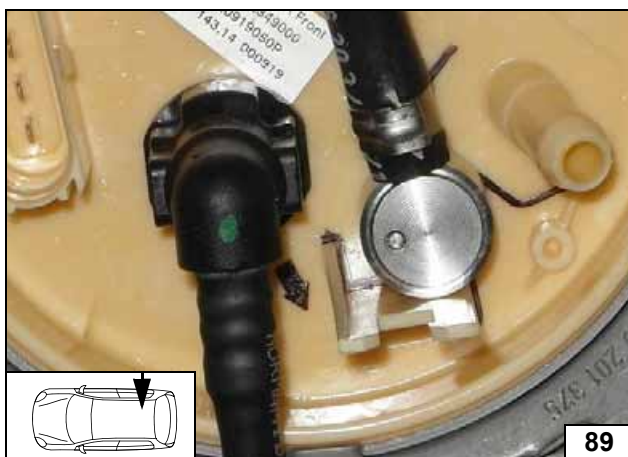

Work step F8.

Ensuring firm seating of FuelFix

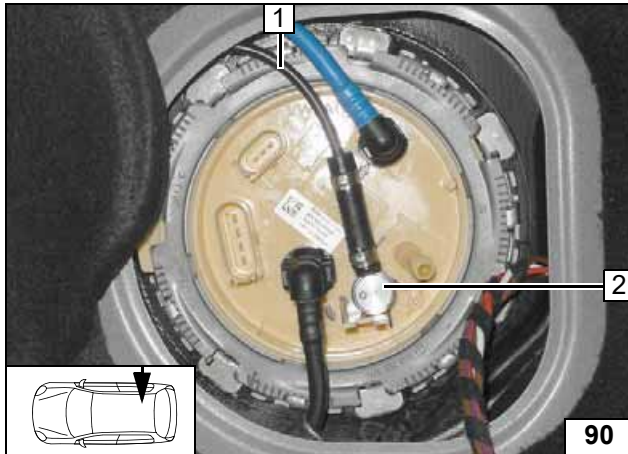

Attach fuel line 1 for tension relief at an appropriate point.



2 FuelFix installed

Securing fuel line

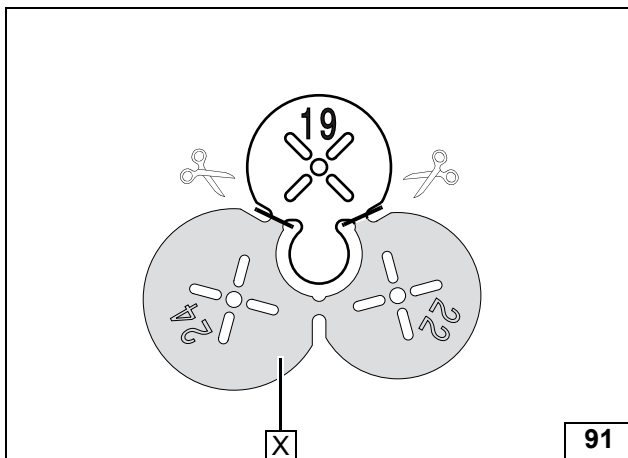

Installing FuelFix for Passat / Superb TDI Front-Wheel Drive

X =

Preparing drilling template

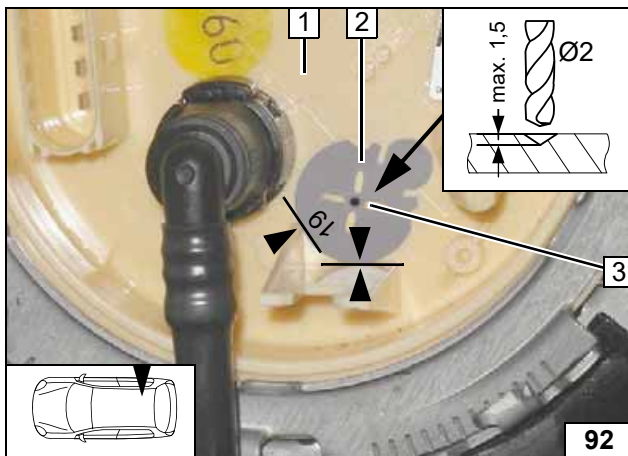

Work steps F1 and F2.

- 1 Tank fitting
- 2 Position Ø19 drilling template as shown
- 3 Ø2 centring hole



Copying hole pattern



Work step F3.

- 1 Hole made with provided drill

Hole for FuelFix

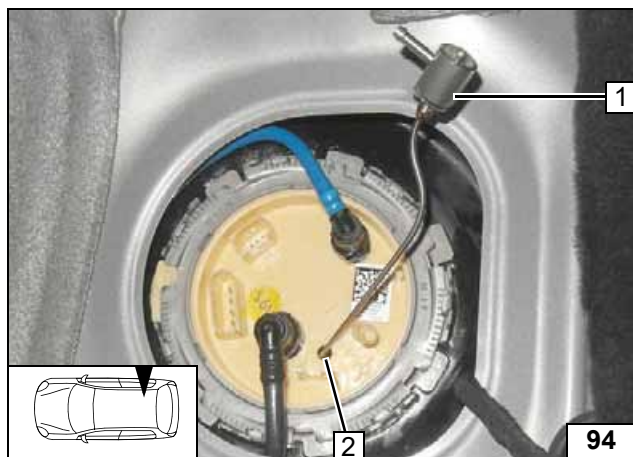

Work steps F4 and F5.

Bend FuelFix 1 according to template and cut to length. Insert into hole 2.



Inserting FuelFix



Work step F5.

Inserting FuelFix

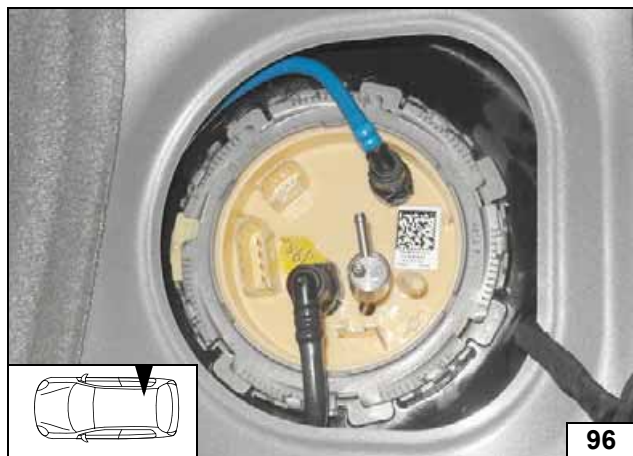

Inserting FuelFix

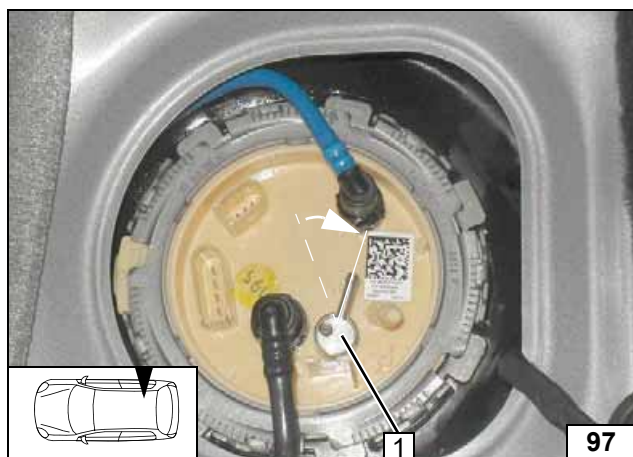

Work steps F5.3 and F5.4.

Align FuelFix 1 as shown.



Aligning FuelFix

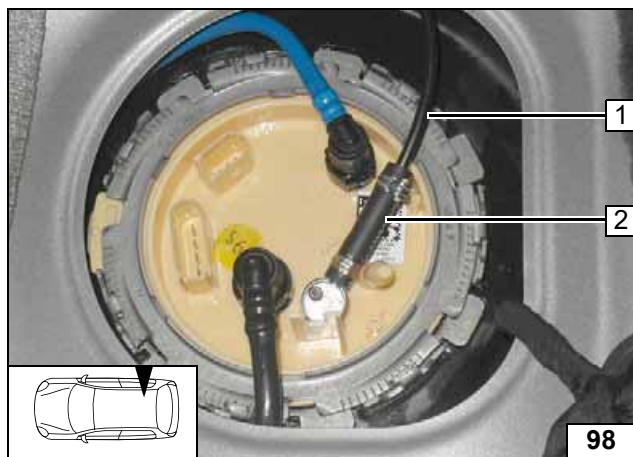

Work step F6.

- 1 Fuel line
- 2 Hose section, Ø10 clamp [2x]

Connect-
ing fuel line

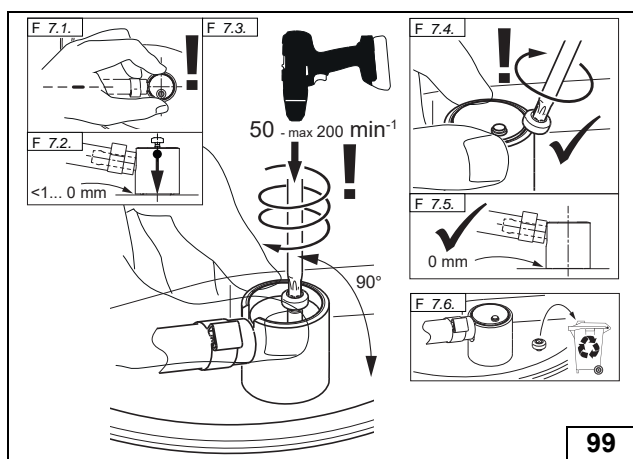

Work step F7.



Installing
FuelFix



Work step F8.

Ensuring
firm seating
of FuelFix

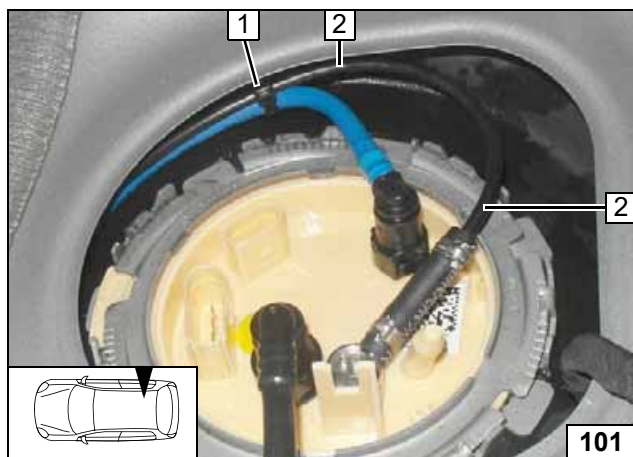

- 1 Cable tie as tension relief
- 2 Fuel line

Securing fuel
line

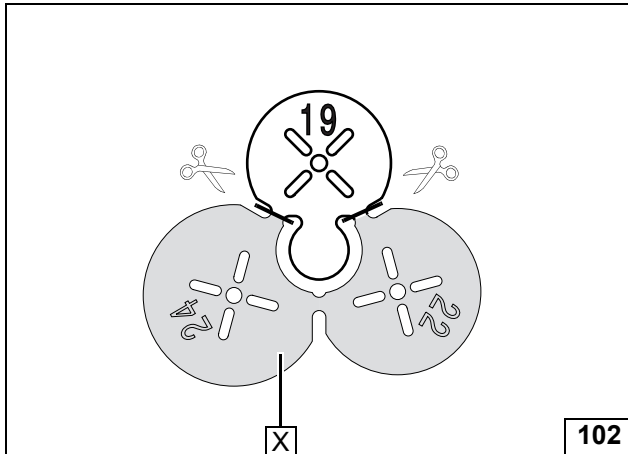
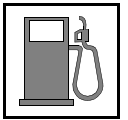

Installing FuelFix for Superb TDI 4x4

X =

Preparing drilling template

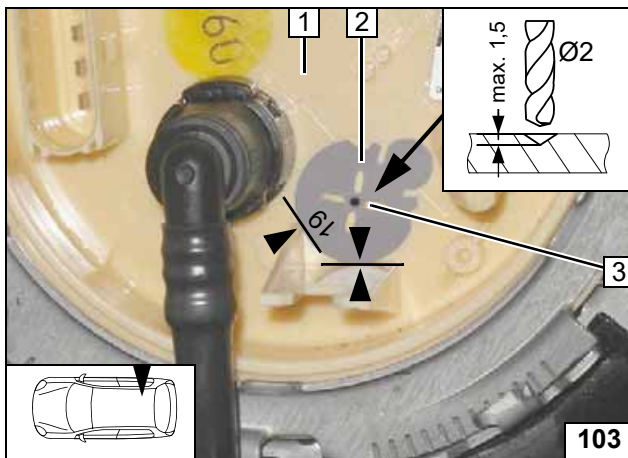

Work steps F1 and F2.

- 1 Tank fitting
- 2 Position Ø19 drilling template as shown
- 3 Ø2 centring hole



Copying hole pattern

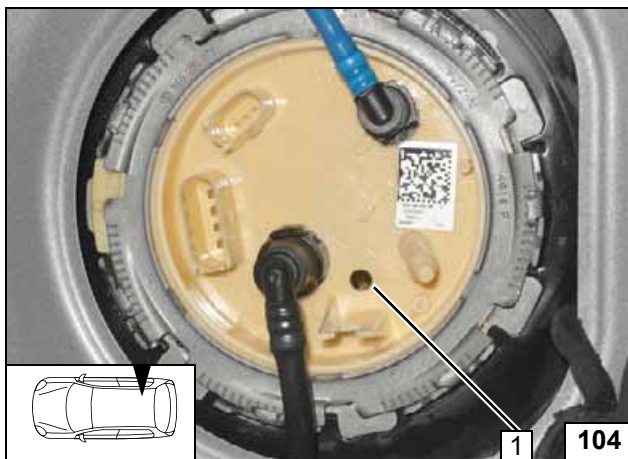

Work step F3.

- 1 Hole made with provided drill

Hole for FuelFix

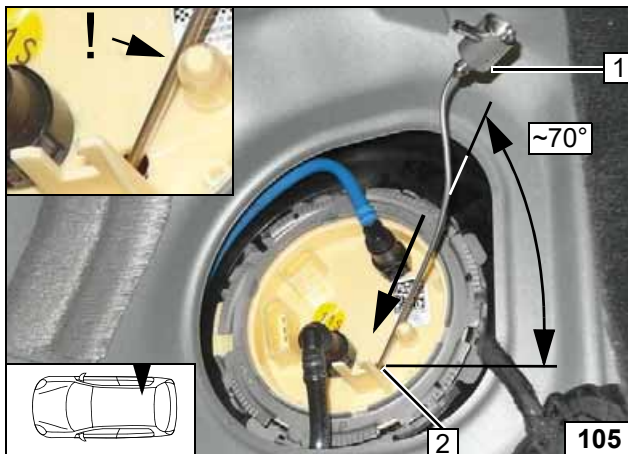

Work steps F4 and F5.

Bend FuelFix 1 according to template and cut to length. Insert into hole 2.



Inserting FuelFix



Work step F5.

Inserting
FuelFix

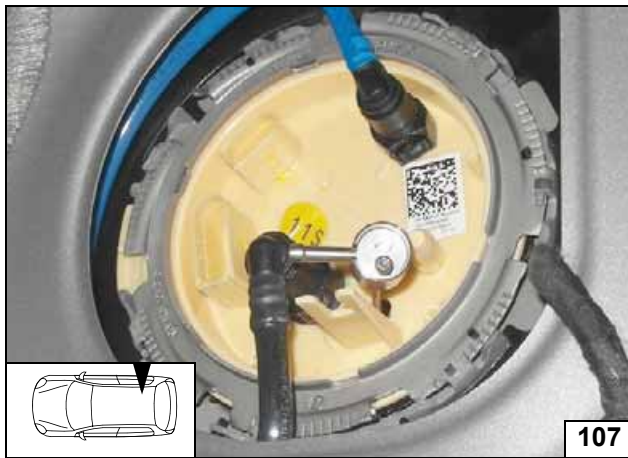

Inserting
FuelFix

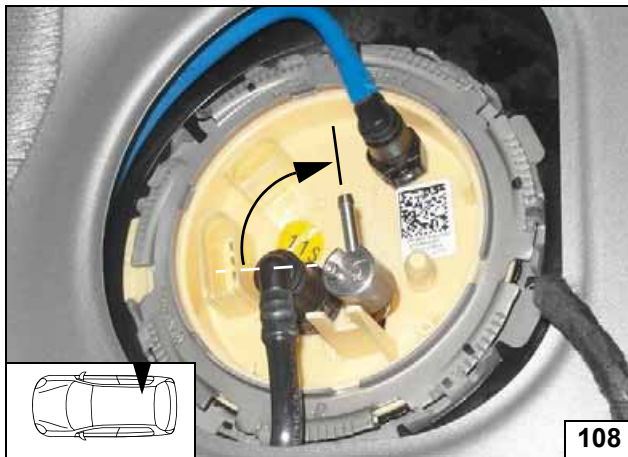

Inserting
FuelFix

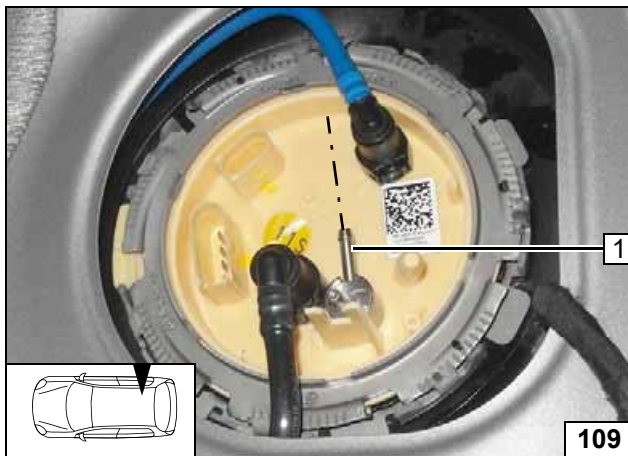

Work steps F5.3 and F5.4.

Align FuelFix 1 as shown.



Aligning
FuelFix

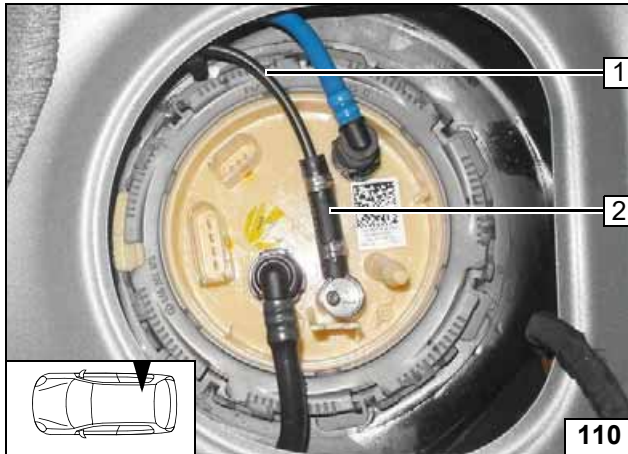
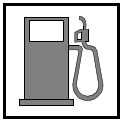

Work step F6.

- 1 Fuel line
- 2 Hose section, Ø10 clamp [2x]

Connect-
ing fuel line

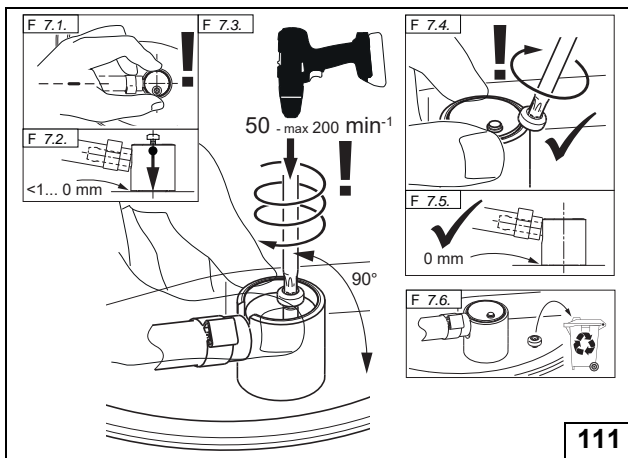

Work step F7.



Installing
FuelFix



Work step F8.

Ensuring
firm seating
of FuelFix

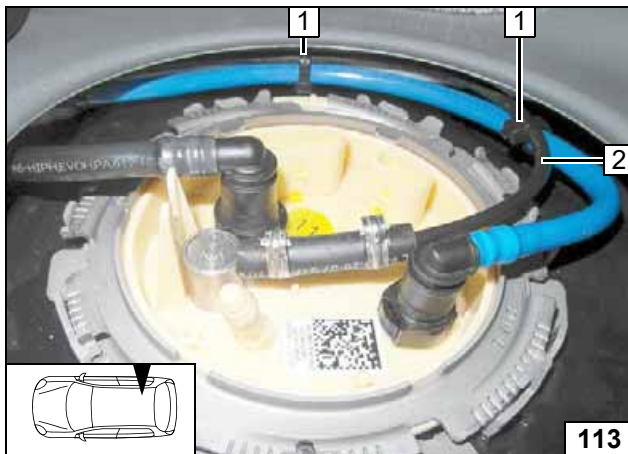

- 1 Cable tie as tension relief [2x]
- 2 Fuel line

Securing fuel
line

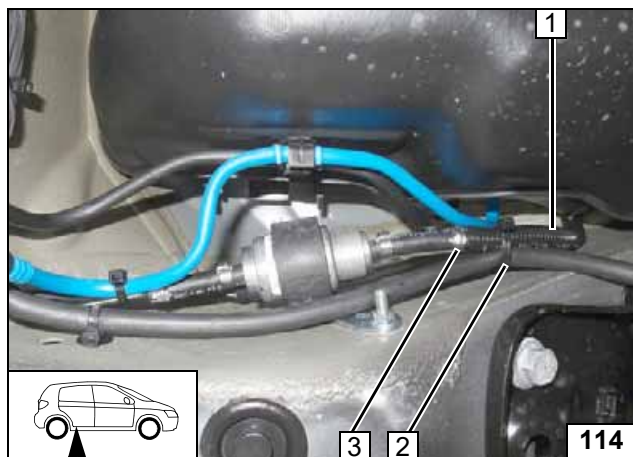

All vehicles

Version 1

Slide Ø10 corrugated tube **1** onto fuel line. Check the position of the components; adjust if necessary. Check that they have freedom of movement.

- 2** Cable tie as tension relief
- 3** FuelFix fuel line, Ø10 clamp



**Connect-
ing meter-
ing pump**

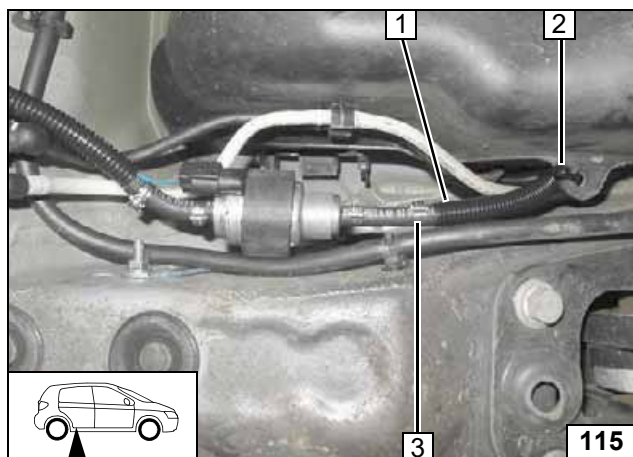

Version 2

Slide Ø10 corrugated tube **1** onto fuel line. Check the position of the components; adjust if necessary. Check that they have freedom of movement.

- 2** Cable tie as tension relief
- 3** FuelFix fuel line, Ø10 clamp [2x]



**Connect-
ing meter-
ing pump**



Coolant circuit for 1.0 / 1.2 / 1.4 TSI







Any coolant running off should be collected in an appropriate container. Route hoses kink-free. Unless specified otherwise, always fasten using cable ties. Position clamps so that other hoses cannot be damaged. The heater must be filled with coolant when installing the hoses.

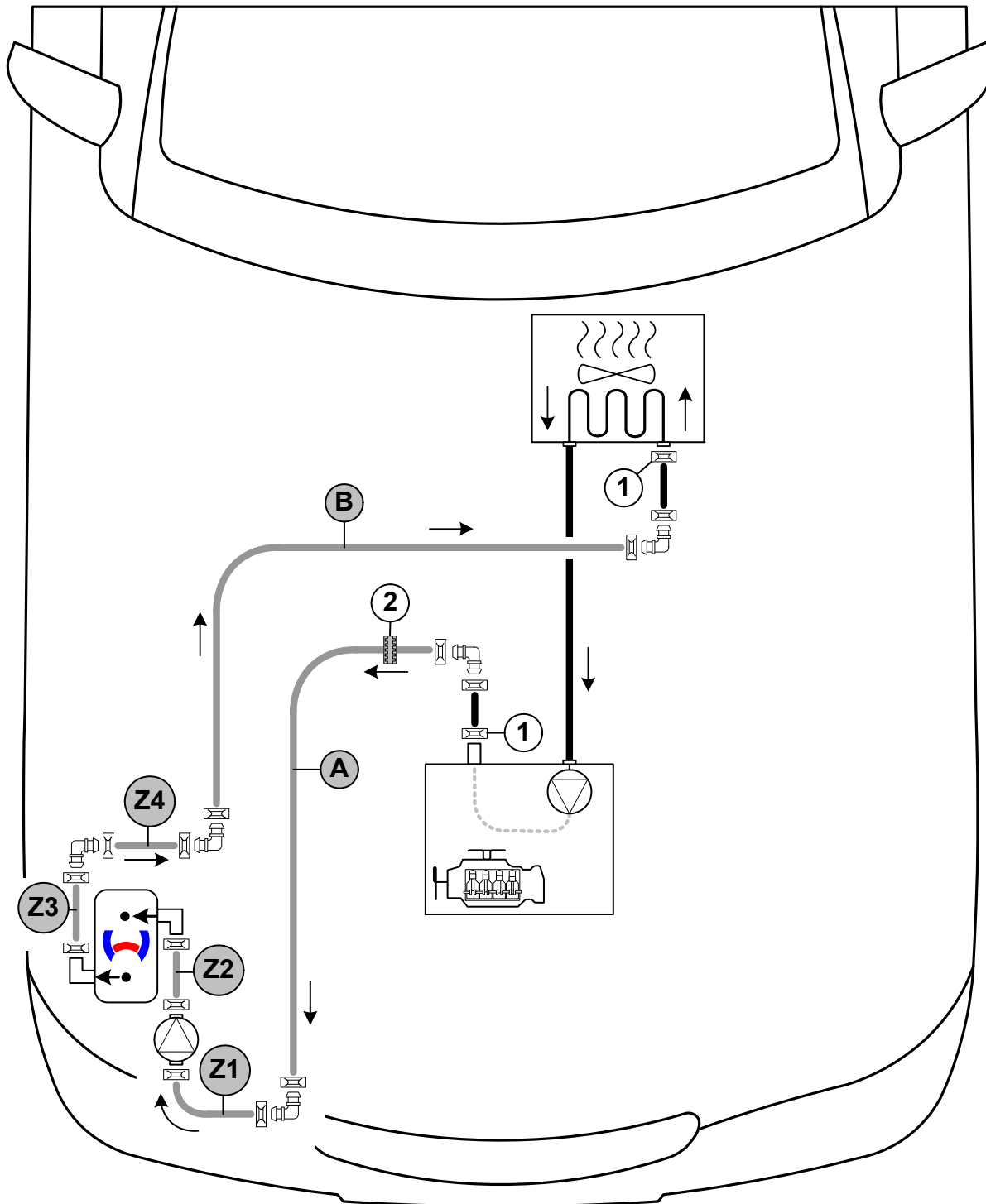

The connection should be modelled on an 'inline' circuit and based on the following diagram:



Hose routing diagram

All spring clips without a specific designation  = Ø25. All connecting pipes  and  = Ø18x18.
 1 = Original vehicle spring clip .
 2 = Black (sw) rubber isolator  only for Passat and Superb!



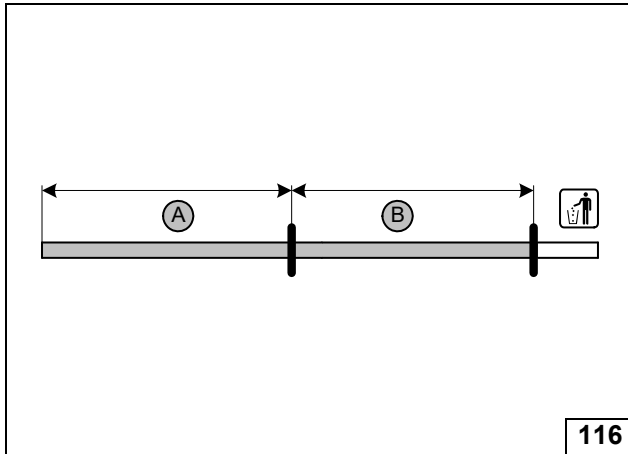

A = 1070
B = 990

Cutting hoses to length

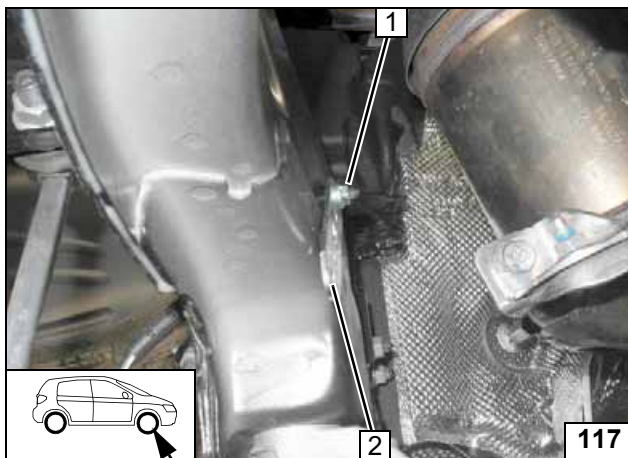

- 1 M6 flanged nut, original vehicle stud bolt
- 2 Perforated bracket

Installing perforated bracket

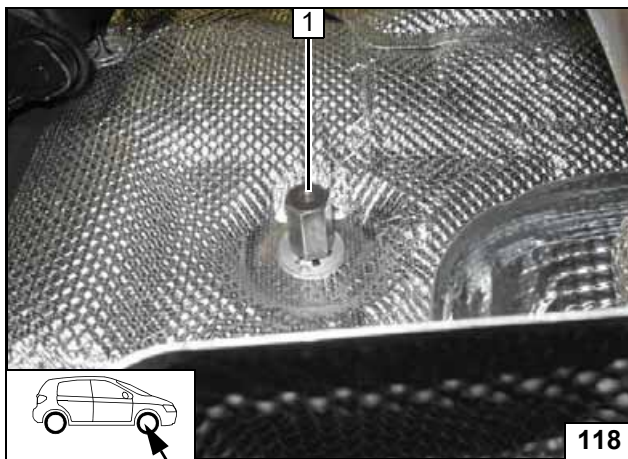

- 1 M6x30 spacer nut, original vehicle stud bolt

Installing spacer nut

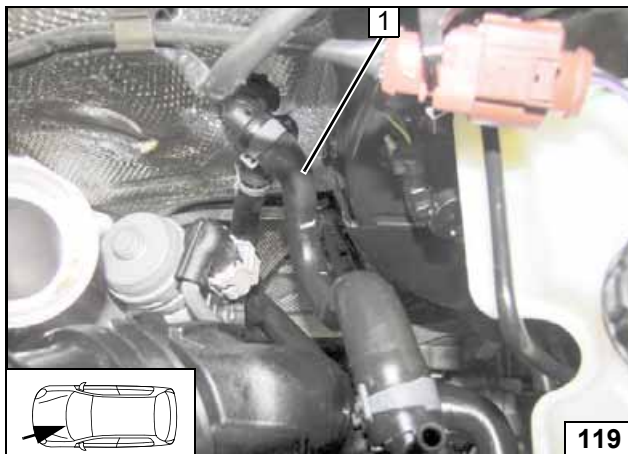

Golf VII / Golf VII Sportsvan, version 1

Remove engine outlet / heat exchanger inlet hose 1. Spring clips will be reused!



Cutting point

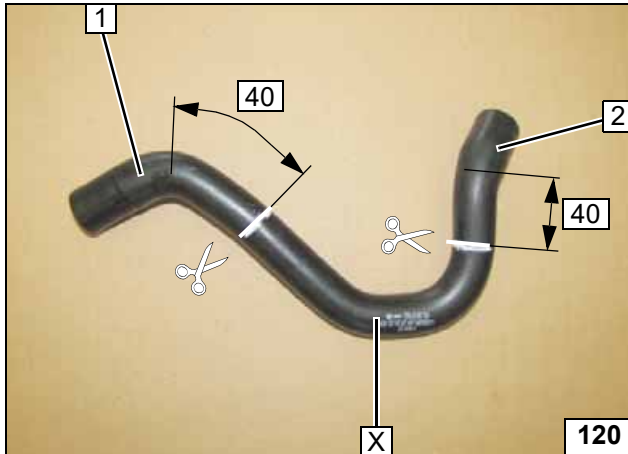

- 1 Engine outlet hose section
- 2 Heat exchanger inlet hose section

X =

Cutting point

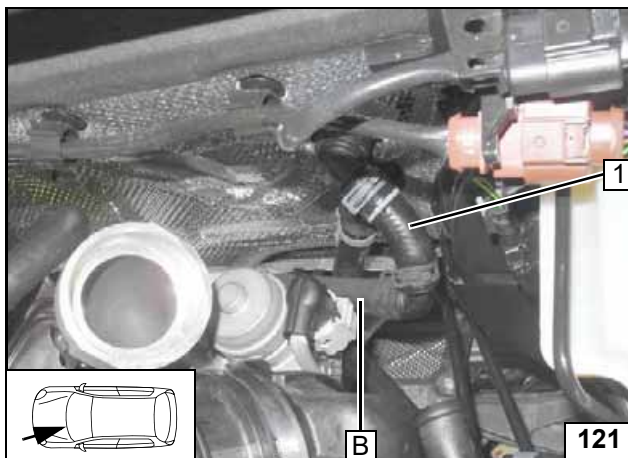

- 1 Heat exchanger inlet hose section

Connect-
ing heat ex-
changer
inlet

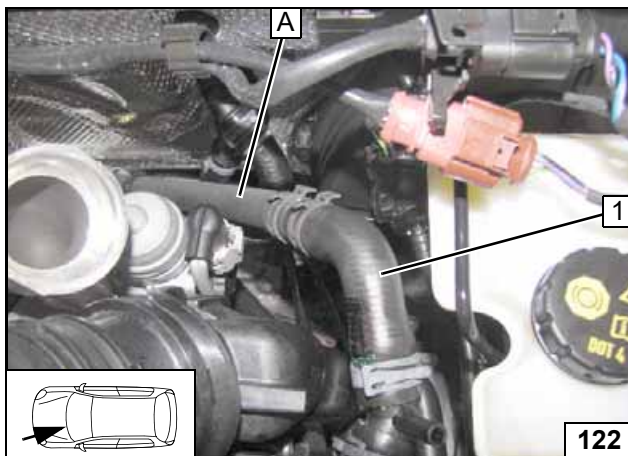

- 1 Engine outlet hose section

Connect-
ing engine
outlet

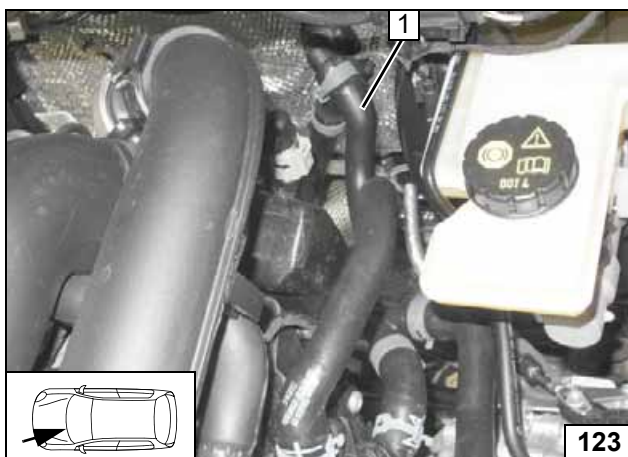

Golf VII / Golf VII Sportsvan, version 2

Remove engine outlet / heat exchanger inlet hose 1. Spring clips will be reused!



Cutting point

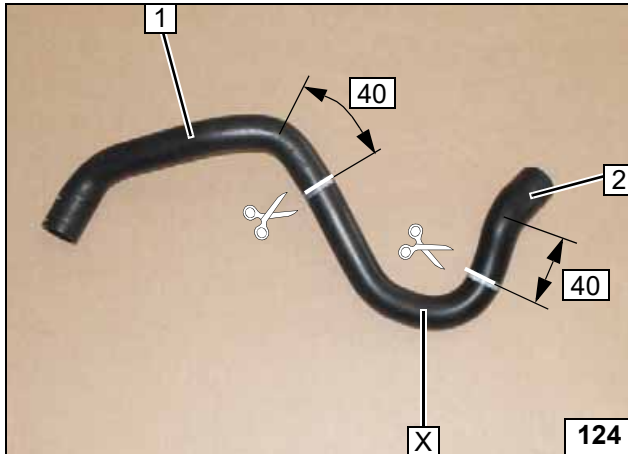
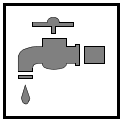

- 1 Engine outlet hose section
- 2 Heat exchanger inlet hose section

X =

Cutting point

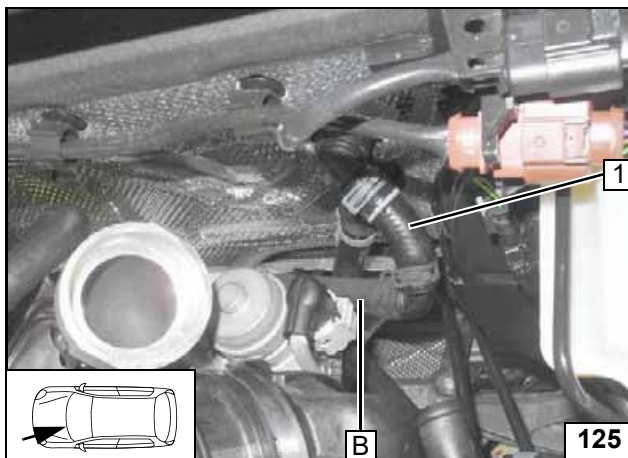

- 1 Heat exchanger inlet hose section

Connecting heat exchanger inlet

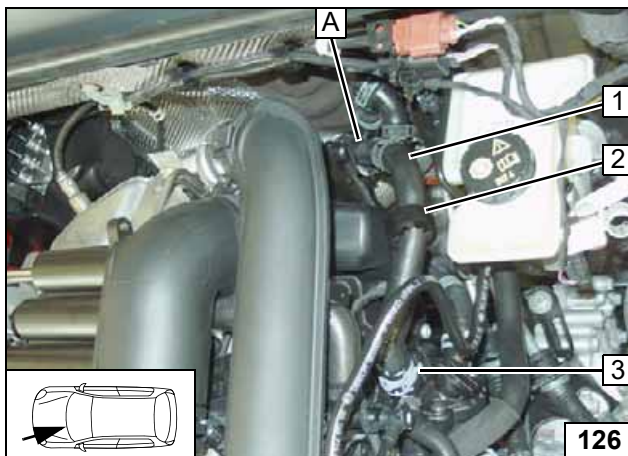

- 1 Engine outlet hose section
- 2 Black (sw) rubber isolator
- 3 Original vehicle spring clip

Connecting engine outlet



Passat / Superb

Remove engine outlet / heat exchanger inlet hose 1. Spring clips will be reused!



Cutting point

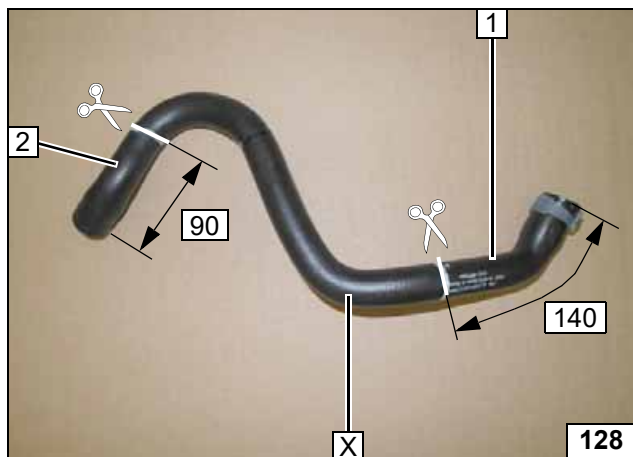

- 1 Engine outlet hose section
- 2 Heat exchanger inlet hose section

X =

Cutting point

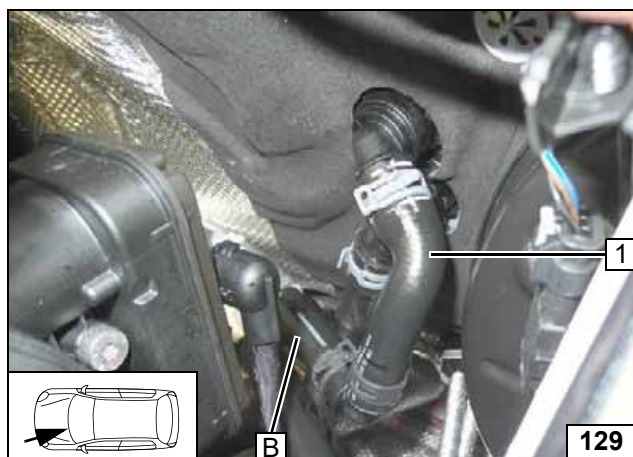

- 1 Heat exchanger inlet hose section

Connect-
ing heat ex-
changer
inlet

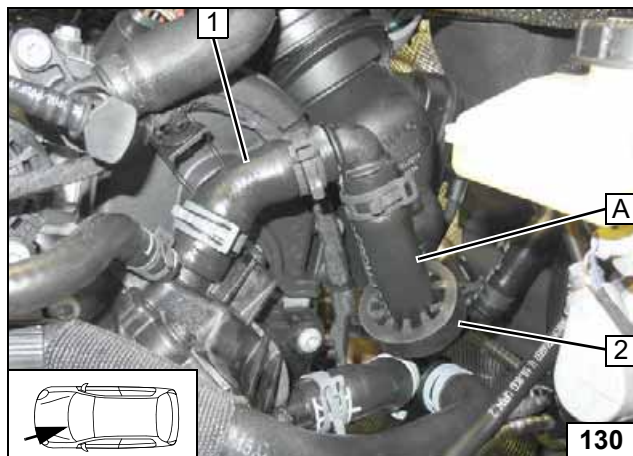

- 1 Engine outlet hose section
- 2 Position black (sw) rubber profile

Connect-
ing engine
outlet

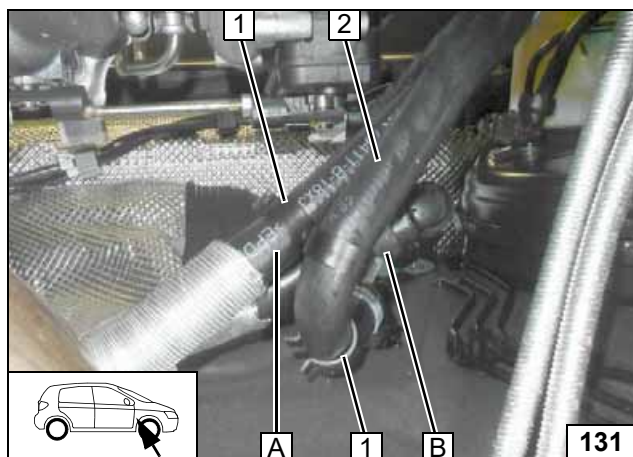

All vehicles

Slide one 600 long heat protection hose each onto hoses A and B.

- 1 Twistable spacer bracket [2x]
- 2 Hose of heat exchanger outlet

Routing on
firewall



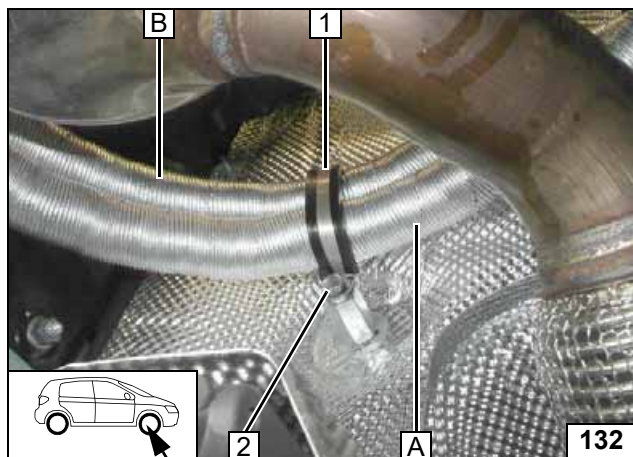

- 1 Ø48 rubber-coated p-clamp
- 2 M6x20 bolt, spring lock washer

Fastening on firewall

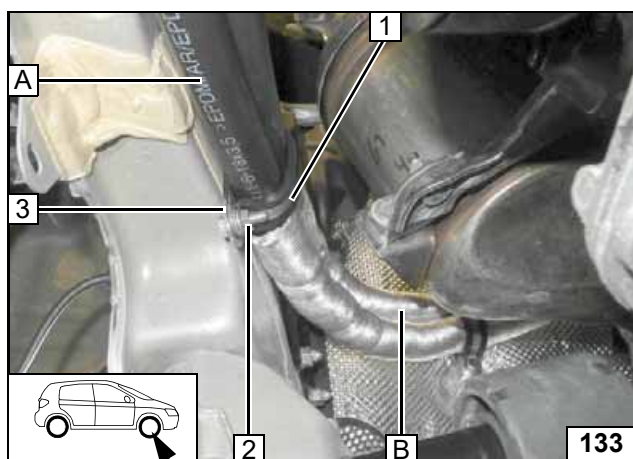

Align hoses. Ensure sufficient distance to catalytic converter, correct if necessary.



- 1 Ø38 rubber-coated p-clamp
- 2 M6x20 bolt, flanged nut
- 3 Perforated bracket

Routing on frame side member

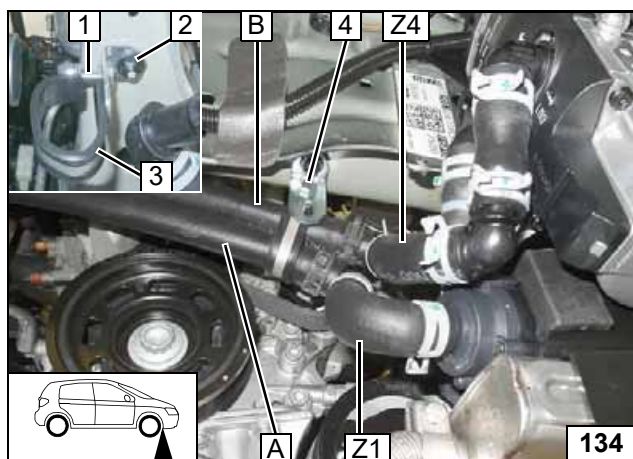

- 1 Loosely mount M6x20 bolt
- 2 Original vehicle stud bolt, angle bracket, plastic nut
- 3 Ø38 rubber-coated p-clamp
- 4 Tighten bolt

Connecting heater

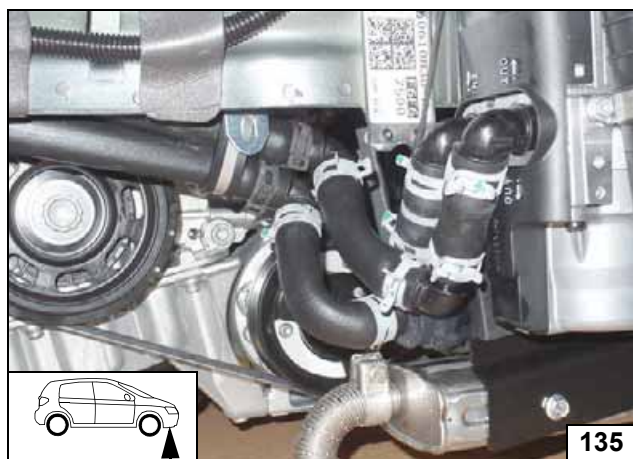

Align hoses and spring clips as shown. Ensure sufficient distance from neighbouring components, correct if necessary.



Aligning hoses and spring clips



Coolant circuit for 1.5 TSI





Any coolant running off should be collected in an appropriate container. Route hoses kink-free. Unless specified otherwise, always fasten using cable ties. Position clamps so that other hoses cannot be damaged. The heater must be filled with coolant when installing the hoses.

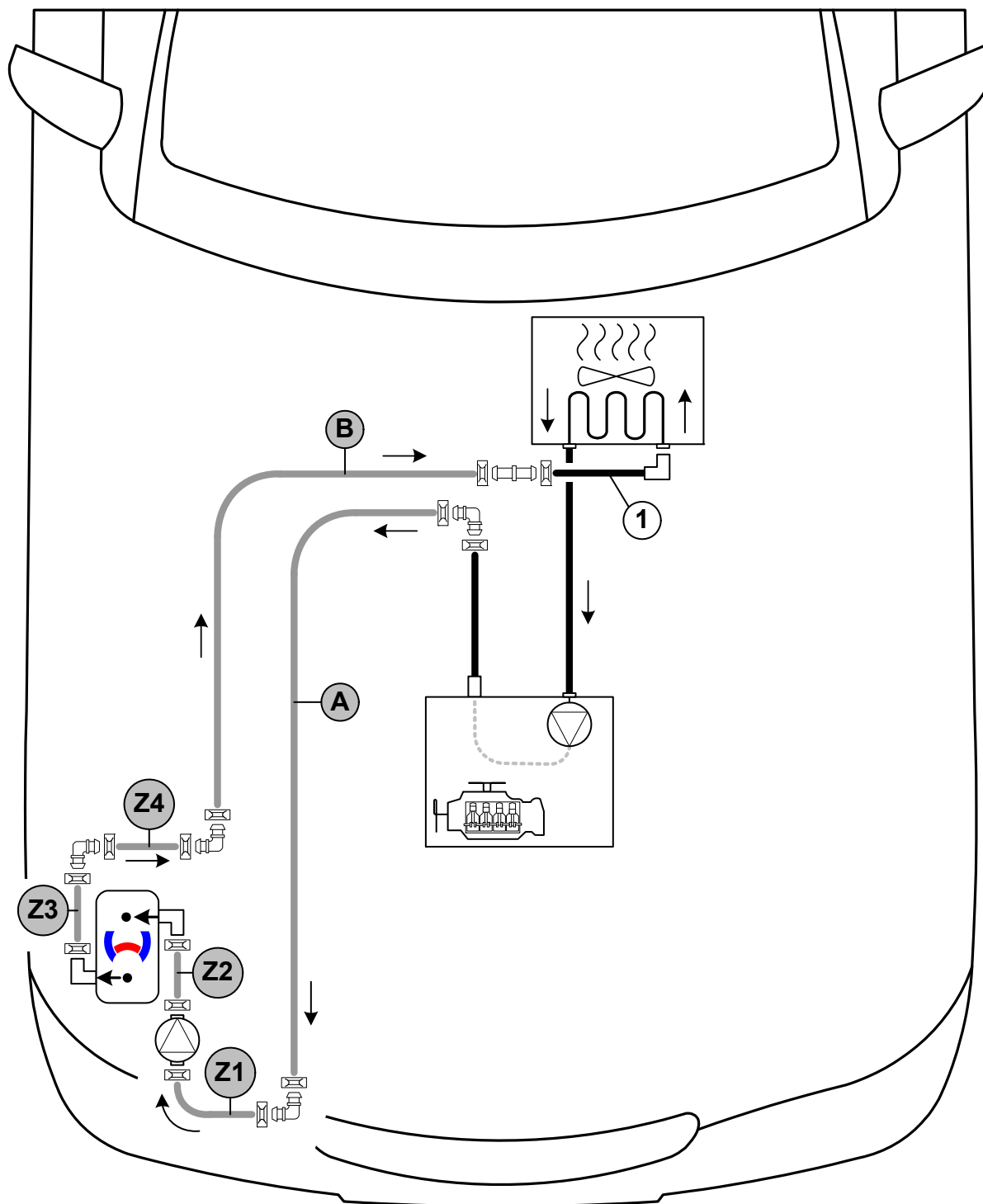

The connection should be modelled on an 'inline' circuit and based on the following diagram:



Hose routing diagram

All spring clips  = Ø25. All connecting pipes  and  = Ø18x18.
1 = Original vehicle coolant hose.



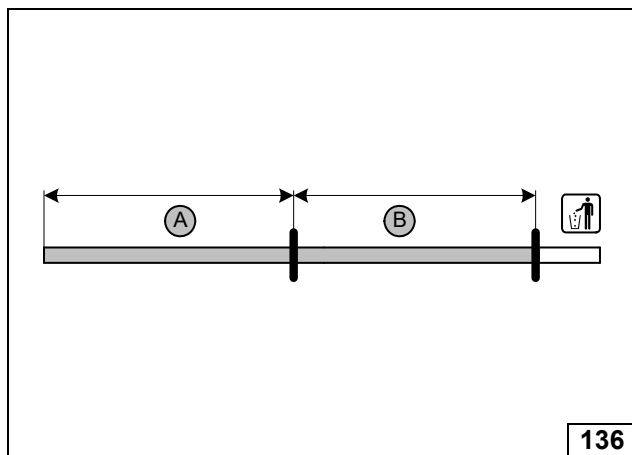

A = 900
B = 900

Cutting hoses to length

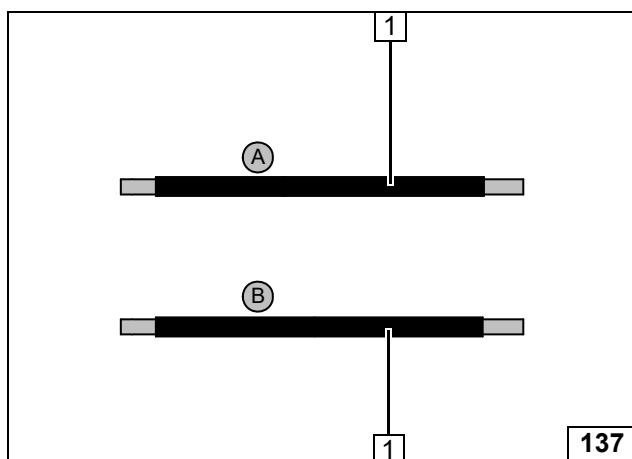

1 Heat protection hose [2x]

Preparing hoses

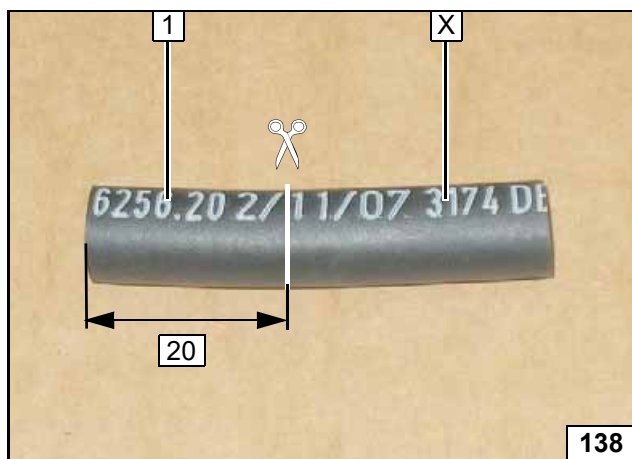

1 Hose section with inner \varnothing 4.5

X =

Shortening hose section

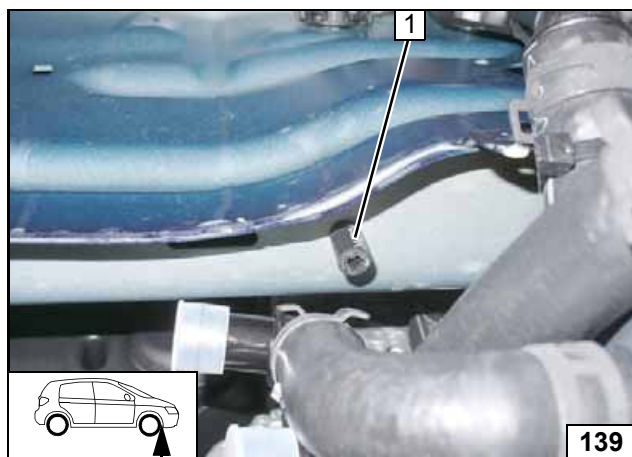

1 Hose section, original vehicle stud bolt

Mounting hose section

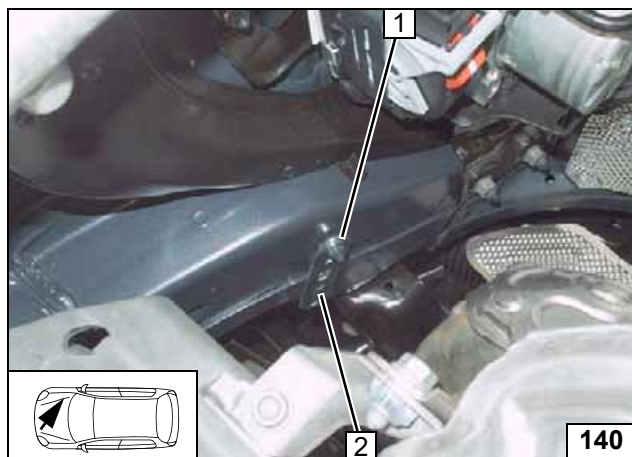
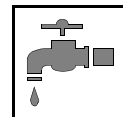

- 1 M6 flanged nut, original vehicle stud bolt
- 2 Perforated bracket

Installing perforated bracket

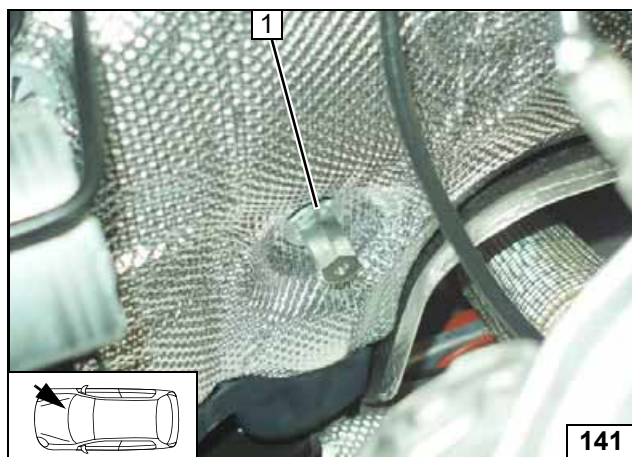

- 1 M6x30 spacer nut, original vehicle stud bolt

Installing spacer nut

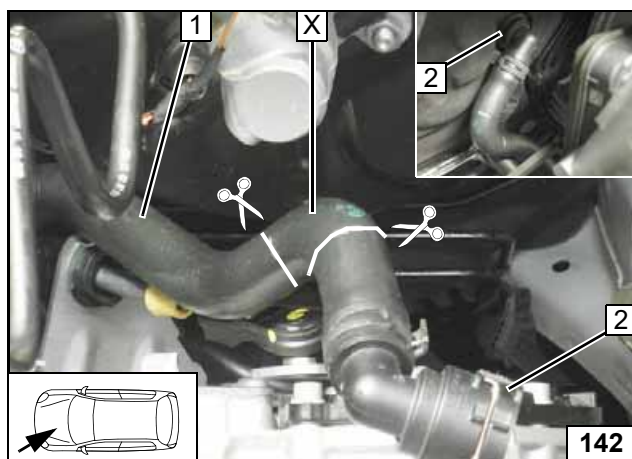

Pull off engine outlet / heat exchanger inlet hose 1 with coupling piece 2 at heat exchanger inlet and route in the engine compartment.

X =

Cutting point

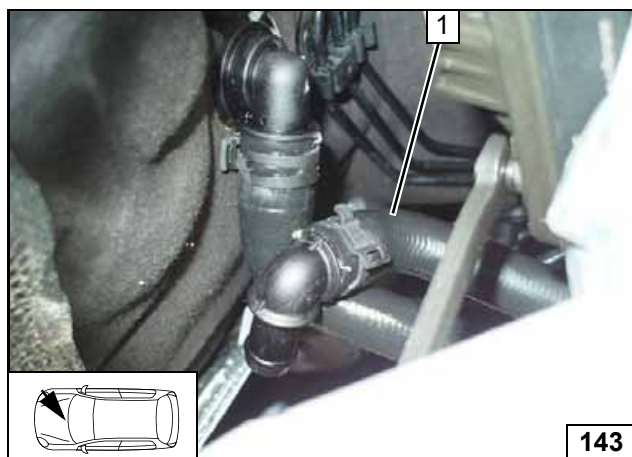

- 1 Engine outlet hose section

Preparing engine outlet hose section

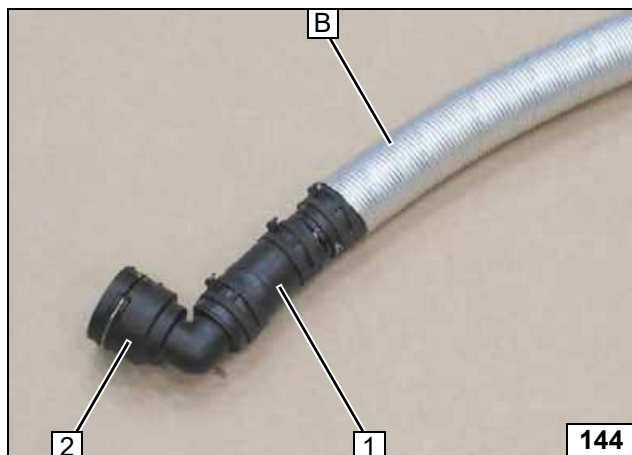

- 1 Heat exchanger inlet hose section
- 2 Heat exchanger inlet coupling piece

Premounting hose section B

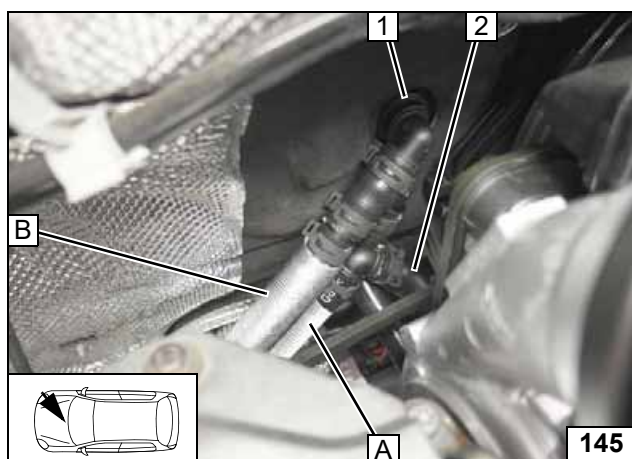

- 1 Heat exchanger inlet coupling piece
- 2 Engine outlet hose section

Connecting engine outlet / heat exchanger inlet

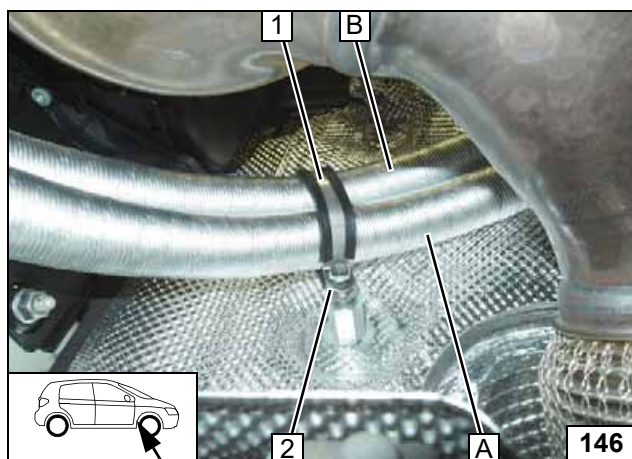

- 1 Ø48 rubber-coated p-clamp
- 2 Mount M6x20 bolt, spring lock washer, Ø48 rubber-coated p-clamp loosely

Routing of hoses

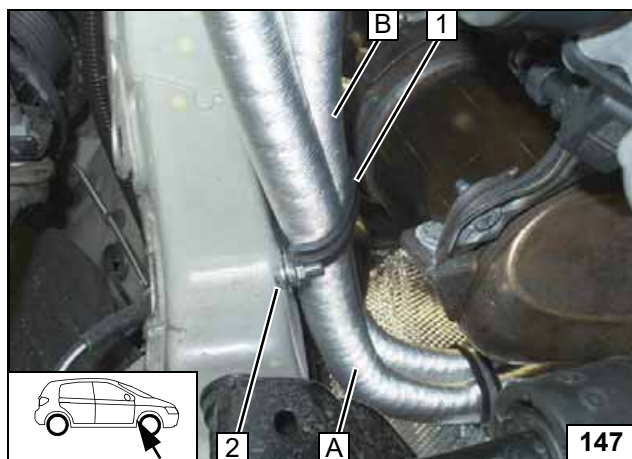

- 1 Ø48 rubber-coated p-clamp
- 2 Mount M6x20 bolt, flanged nut loosely

Routing of hoses

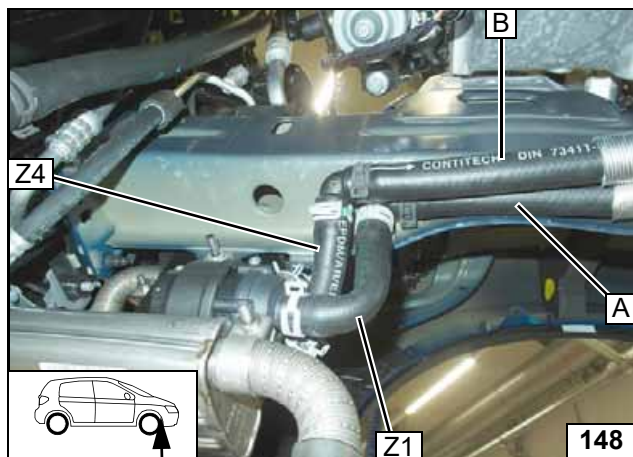

Connection of hoses A and B

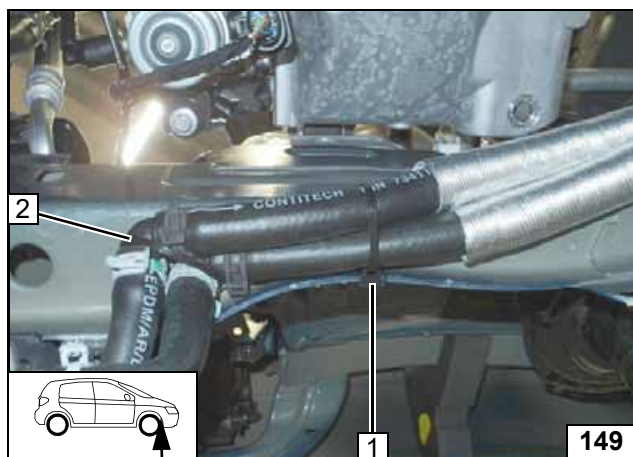

- 1 Edge clip cable tie
- 2 Cable tie

Fastening hoses

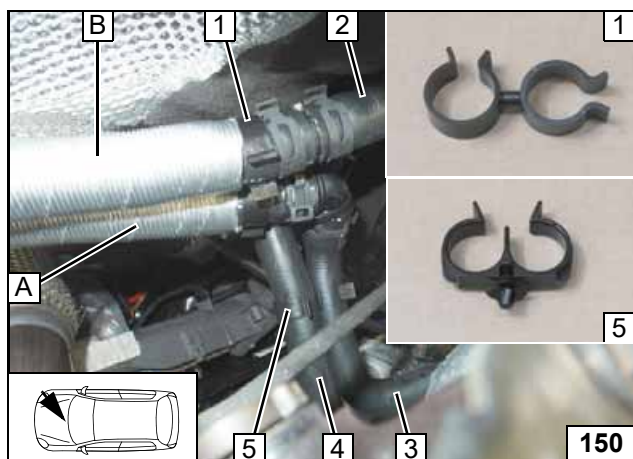

Align hoses and tighten screw connections of rubber-coated p-clamps!

- 1 Hose bracket
- 2 Heat exchanger inlet hose section
- 3 Engine outlet hose section
- 4 Heat exchanger outlet / engine inlet hose
- 5 Hose bracket

Fastening hoses



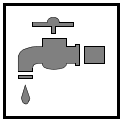

Coolant circuit for TDI front-wheel drive



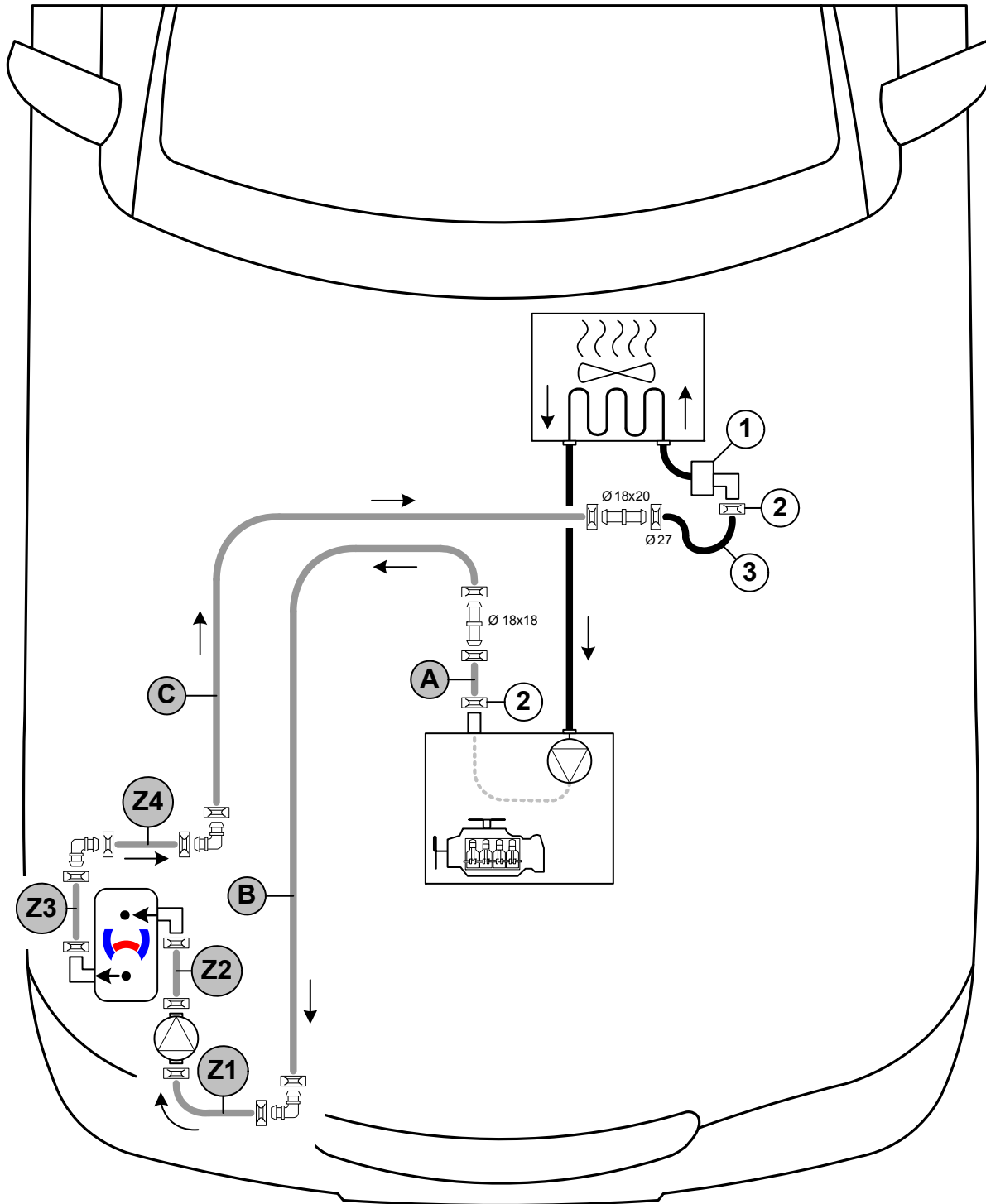

Any coolant running off should be collected in an appropriate container. Route hoses kink-free. Unless specified otherwise, always fasten using cable ties. Position clamps so that other hoses cannot be damaged. The heater must be filled with coolant when installing the hoses.

The connection should be modelled on an 'inline' circuit and based on the following diagram:



Hose routing diagram

All spring clips without a specific designation  = Ø25. All connecting pipes  = Ø18x18.

1 = EGR!

2 = Original vehicle spring clip .

3 = Original vehicle hose



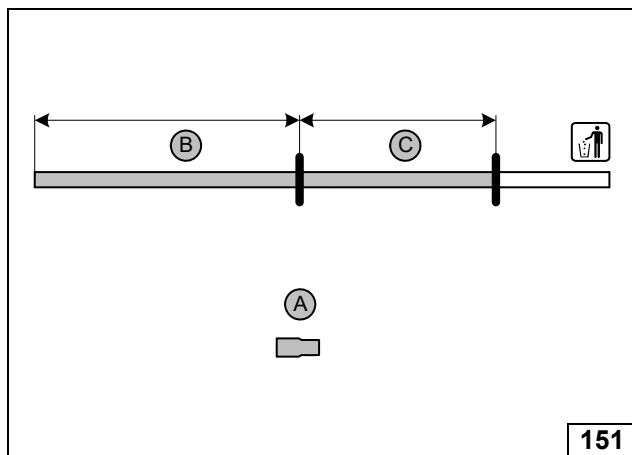

- A = Ø18x20
- B = 1020
- C = 980

Cutting hoses to length

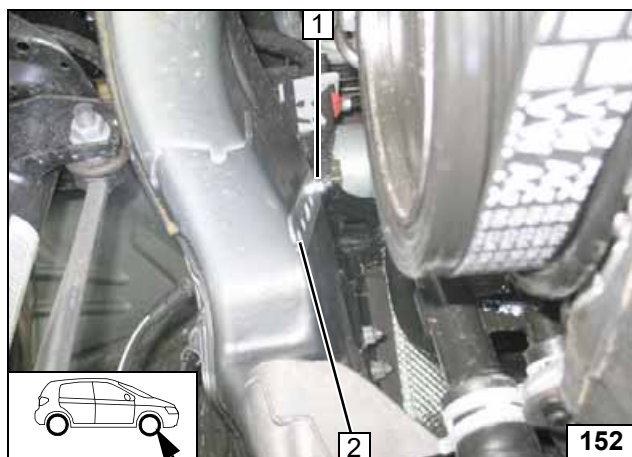

- 1 M6 flanged nut, original vehicle stud bolt
- 2 Perforated bracket

Installing perforated bracket

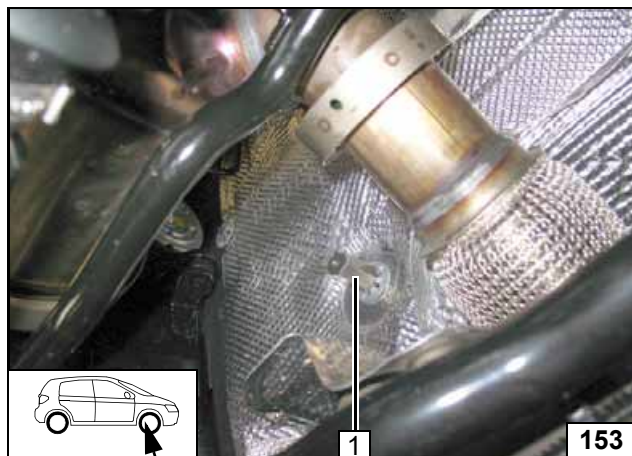

- 1 M6x30 spacer nut, original vehicle stud bolt

Installing spacer nut

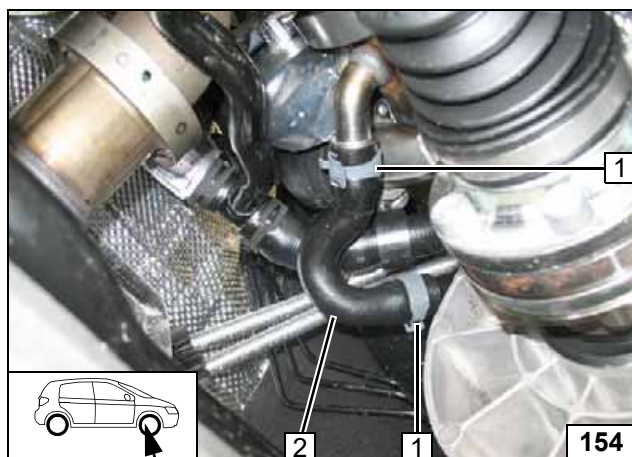

Remove hose from engine outlet / EGR inlet 2. Spring clips 1 will be reused.



Cutting point

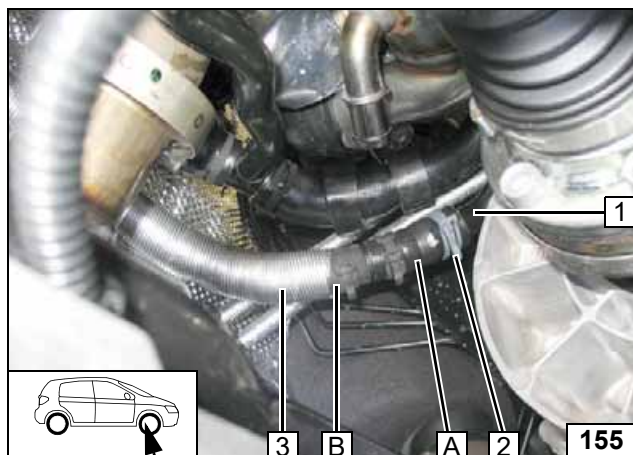
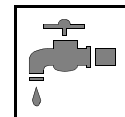

Slide 600 long heat protection hose 3 onto hose B.

- 1 Pipe of engine outlet
- 2 Original vehicle spring clip



**Connect-
ing engine
outlet**

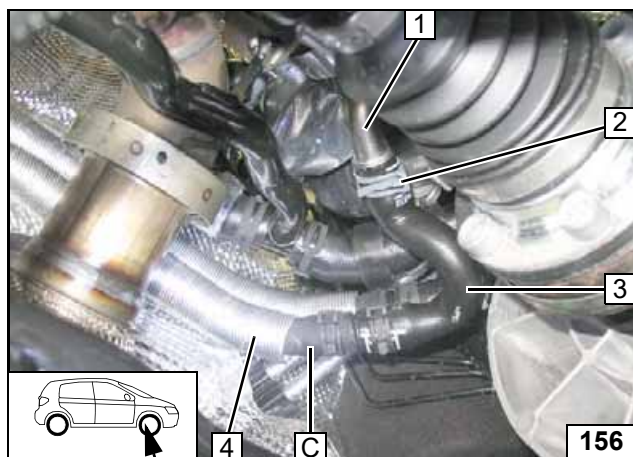

Slide 600 long heat protection hose 4 onto hose C.

- 1 Pipe of EGR
- 2 Original vehicle spring clip
- 3 Original vehicle hose



**Connect-
ing heat ex-
changer
inlet**

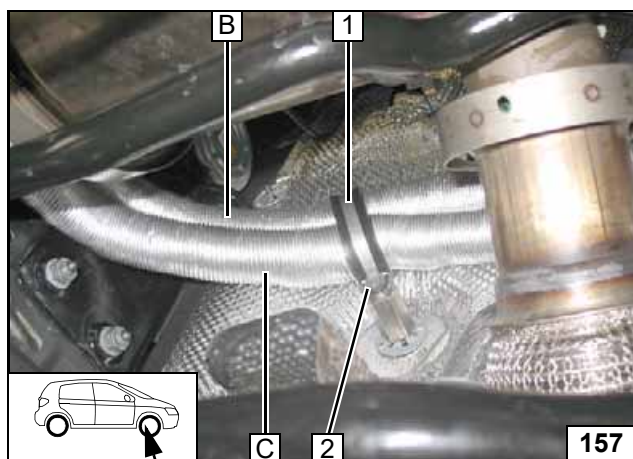

- 1 Ø48 rubber-coated p-clamp
- 2 M6x20 bolt, spring lock washer

**Fastening on
firewall**

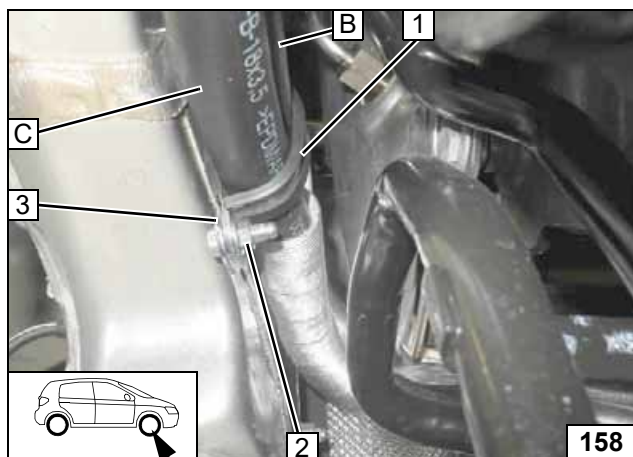

- 1 Ø38 rubber-coated p-clamp
- 2 M6x20 bolt, flanged nut
- 3 Perforated bracket

**Routing on
frame side
member**



Align hoses. Ensure sufficient distance to catalytic converter at position **1**, correct if necessary.



Routing in engine compartment

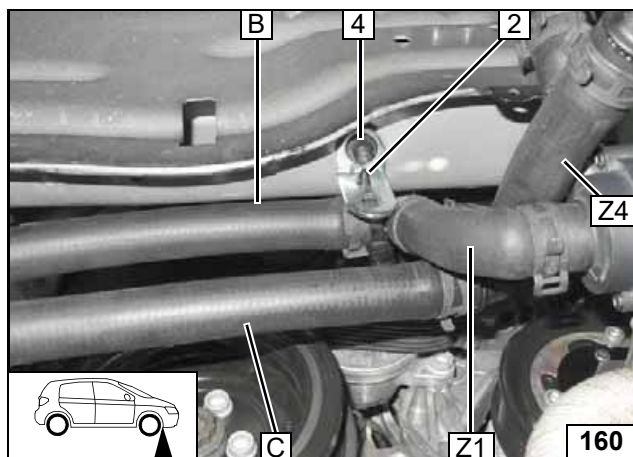

- 1 Original vehicle stud bolt, angle bracket, plastic nut
- 2 Clip-type cable tie around hose **B**

Connecting heater

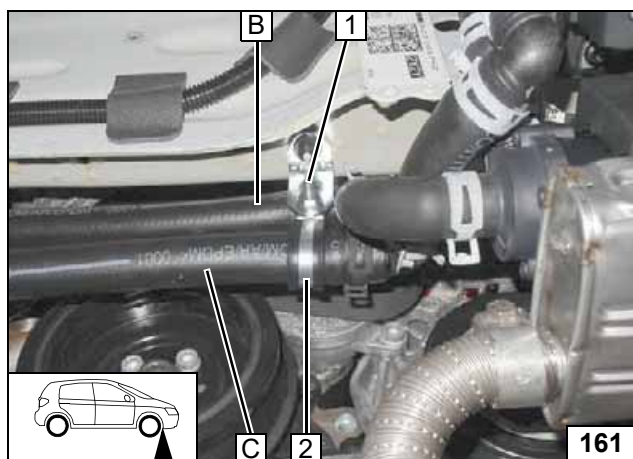

Align hoses and spring clips as shown. Ensure sufficient distance from neighbouring components, correct if necessary.



- 1 M6x20 bolt
- 2 Ø38 rubber-coated p-clamp

Connecting heater



Coolant circuit for Superb 2.0 TDI 4x4 and 1.6 TDI



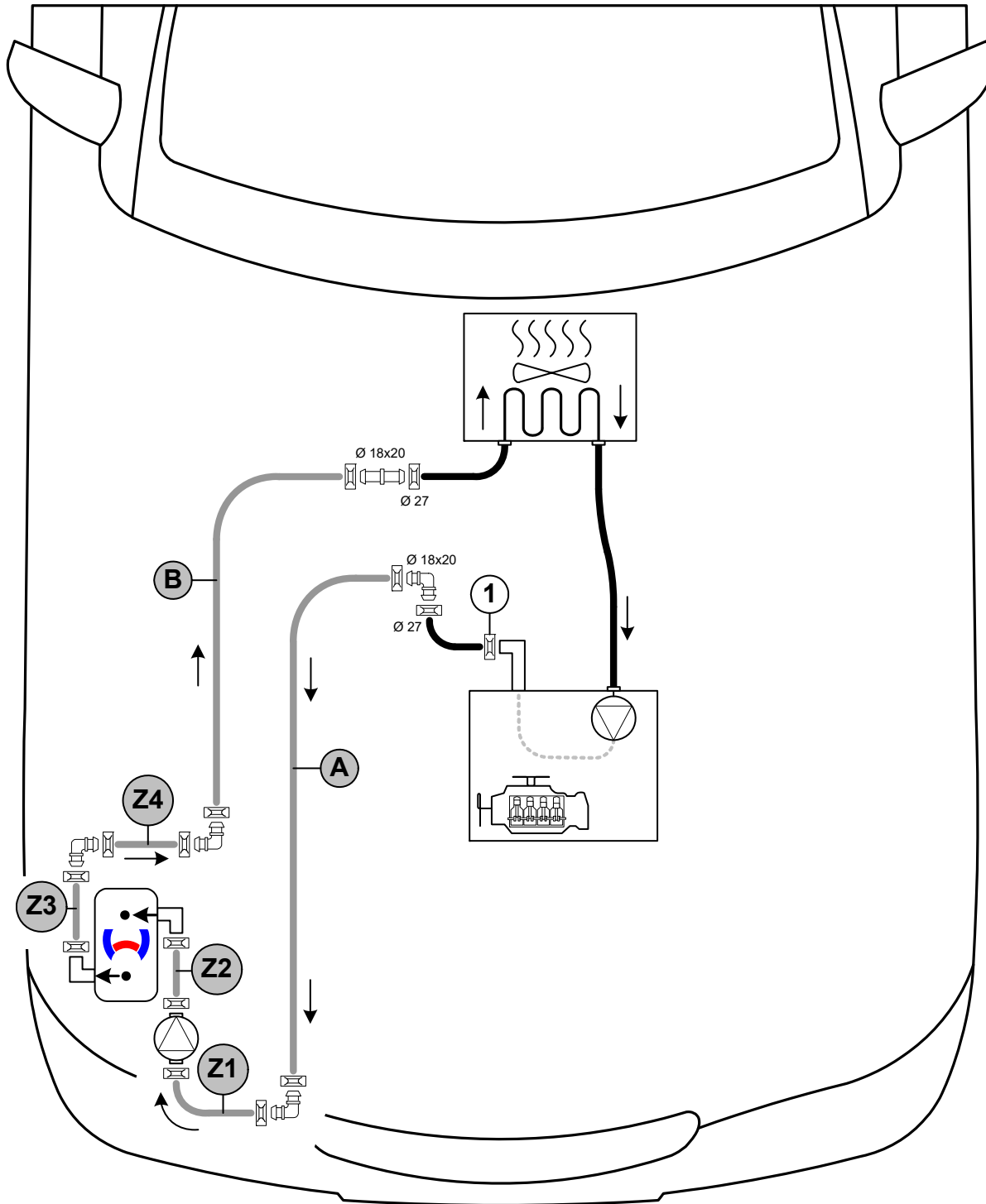

Any coolant running off should be collected in an appropriate container. Route hoses kink-free. Unless specified otherwise, always fasten using cable ties. Position clamps so that other hoses cannot be damaged. The heater must be filled with coolant when installing the hoses.

The connection should be modelled on an 'inline' circuit and based on the following diagram:



Hose routing diagram

All spring clips without a specific designation  = Ø25.
 All connecting pipes without a specific designation  = Ø18x18
 1 = Original vehicle spring clip .



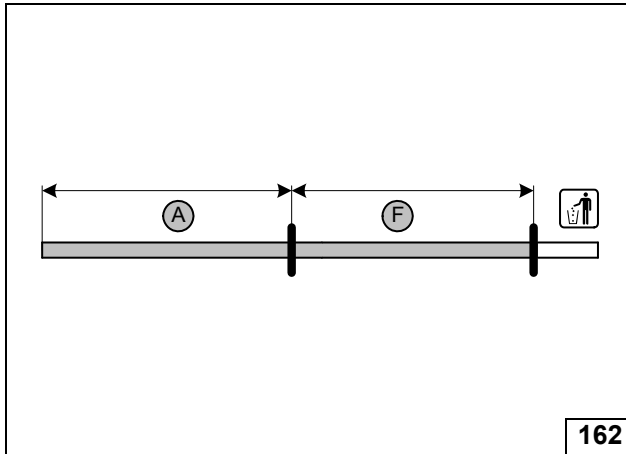

A = 920
B = 910

Cutting hoses to length

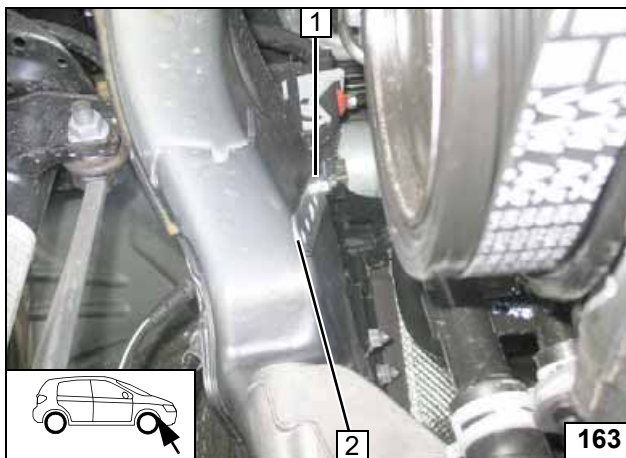

- 1 M6 flanged nut, original vehicle stud bolt
- 2 Perforated bracket

Installing perforated bracket

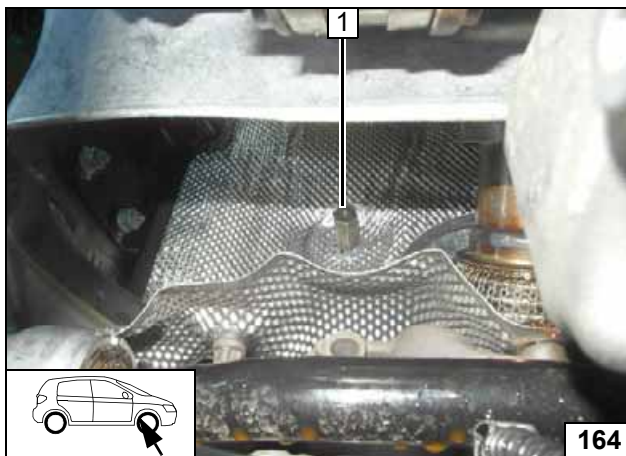

- 1 M6x30 spacer nut, original vehicle stud bolt

Installing spacer nut

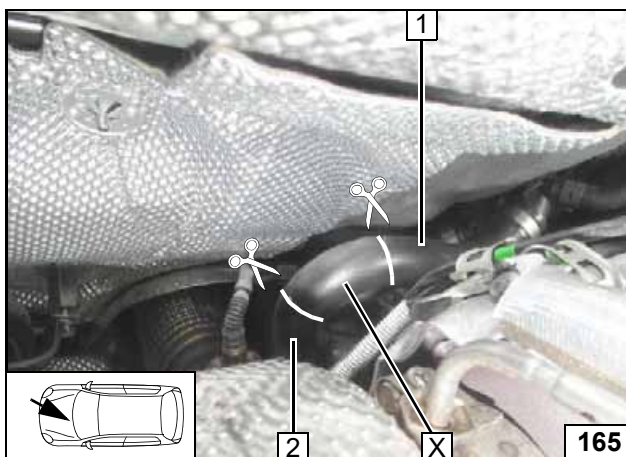

Cut off hose of engine outlet / heat exchanger inlet at the markings. Remove hose section on engine outlet **2**. The spring clip of the engine outlet connection piece will be reused!

- 1 Heat exchanger inlet hose section

X =

Cutting point

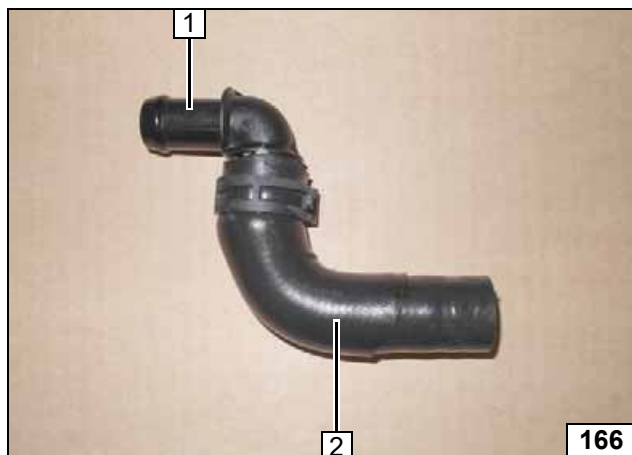

- 1 90°, Ø18x20 connecting pipe, Ø27 spring clip
- 2 Engine outlet hose section

Preparing engine outlet hose section

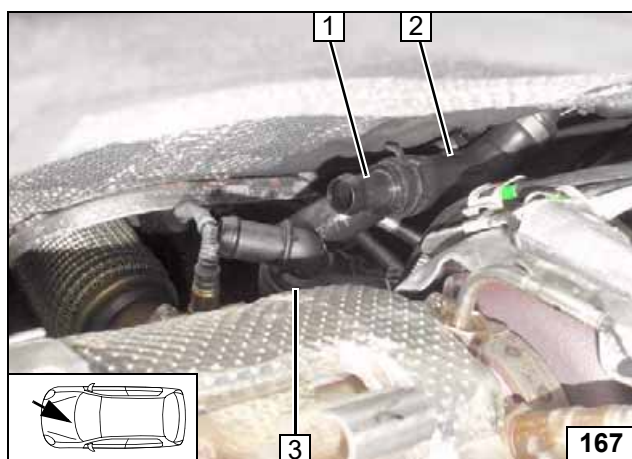

Install hose section of engine outlet **3** with original vehicle spring clip on engine outlet.



- 1 Ø18x20 connecting pipe, Ø27 spring clip
- 2 Heat exchanger inlet hose section

Installing engine outlet hose section

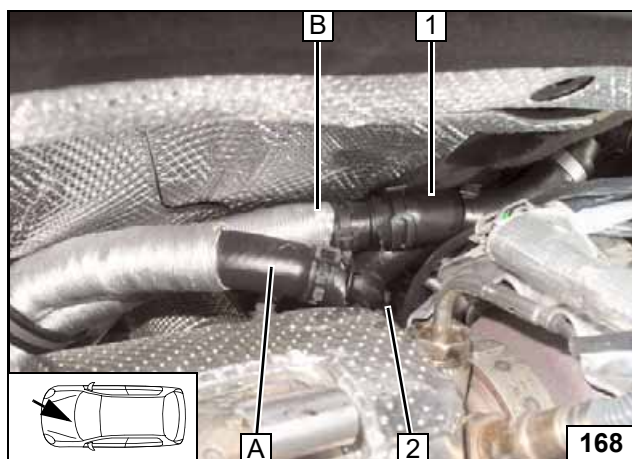

Slide one 600 long heat protection hose each onto hoses **A** and **B**.



- 1 Heat exchanger inlet hose section
- 2 Engine outlet hose section

Connecting engine outlet / heat exchanger inlet

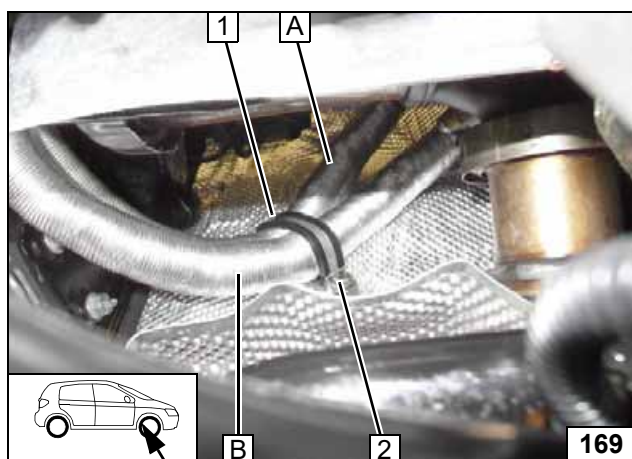

- 1 Ø48 rubber-coated p-clamp
- 2 M6x20 bolt, spring lock washer

Fastening on firewall

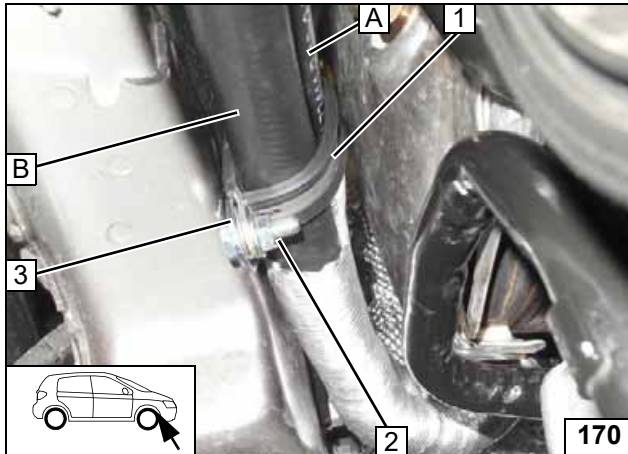

- 1 Ø38 rubber-coated p-clamp
- 2 M6x20 bolt, flanged nut
- 3 Perforated bracket

Routing on frame side member

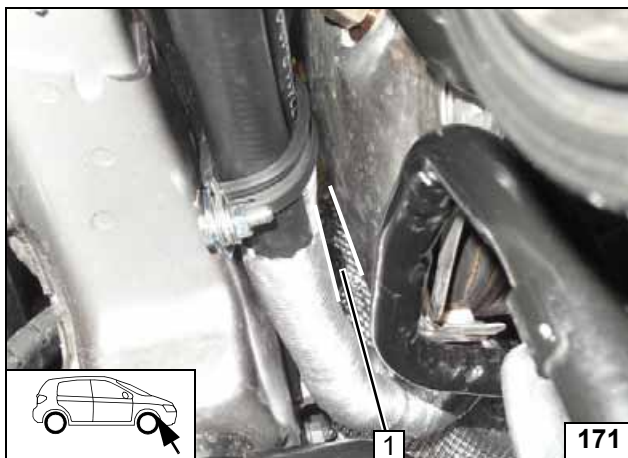

Align hoses. Ensure sufficient distance to catalytic converter at position 1, correct if necessary.



Routing in engine compartment

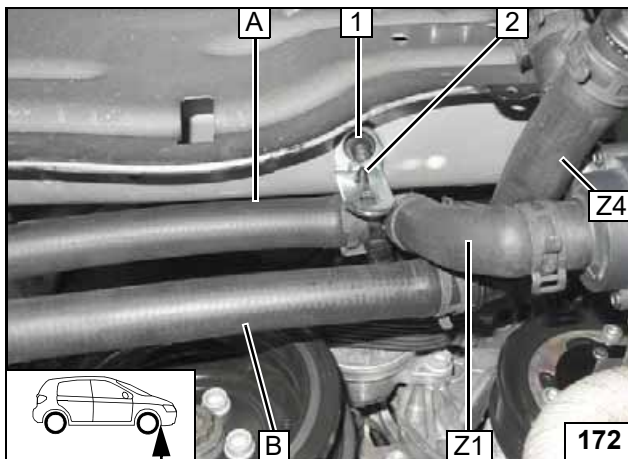

- 1 Original vehicle stud bolt, angle bracket, plastic nut
- 2 Clip-type cable tie around hose A

Connecting heater

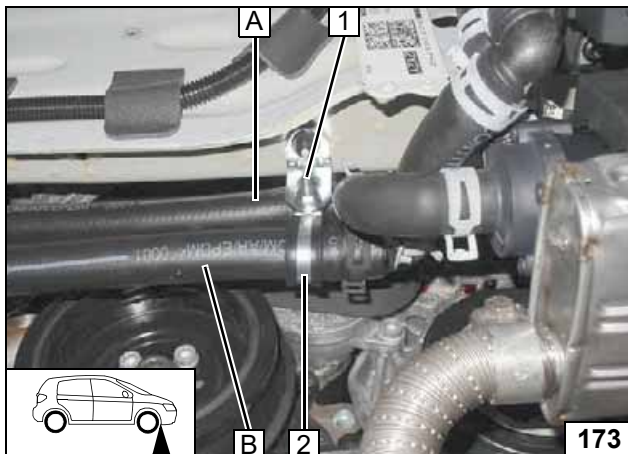

Align hoses and spring clips as shown. Ensure sufficient distance from neighbouring components, correct if necessary.



Connecting heater

- 1 M6x20 bolt
- 2 Ø38 rubber-coated p-clamp

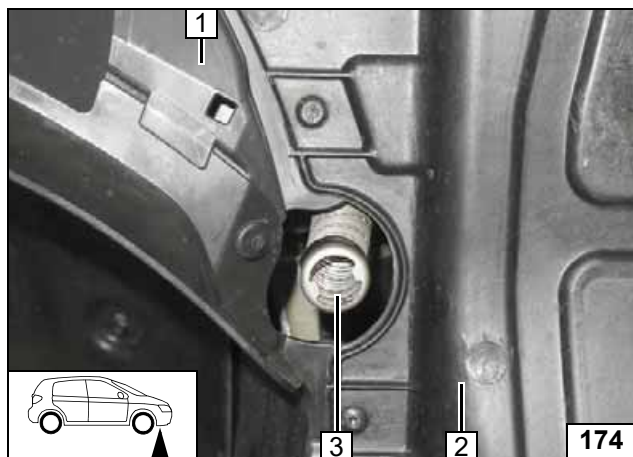

Final work

Align exhaust outlet **3** with centre of pass through.

- 1 Wheel well trim installed
- 2 Underride protection installed



Aligning exhaust pipe



Ensure sufficient distance between wheel well trim **2** and silencer **1**, correct if necessary.

$\geq 10 \text{ mm}$



Aligning exhaust pipe / silencer

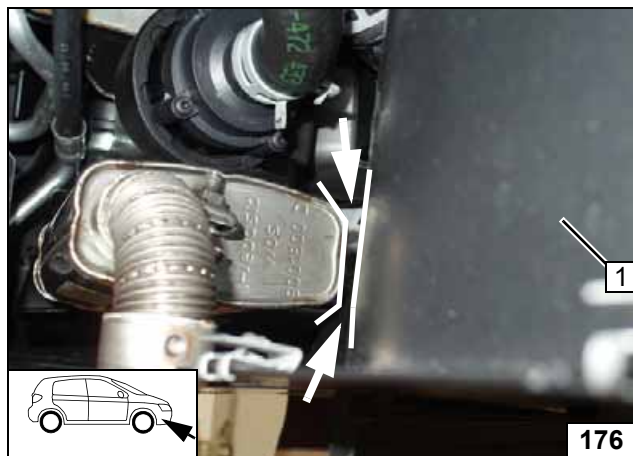

Ensure sufficient distance between exhaust silencer and wheel-well inner panel **1**, correct if necessary.

$\geq 10 \text{ mm}$



Aligning silencer



Reassemble the components in reverse order. Check all hoses, clamps and all electrical connections for firm seating. Insulate and tie back loose lines.

Only use manufacturer-approved coolant. Spray the heater components with anti-corrosion wax (Tectyl 100K).

- **Connect the battery.**
- **Fill and bleed the coolant circuit according to the vehicle manufacturer's instructions.**
- **Program MultiControl CAR, teach Telestart transmitter.**
- **For initial start-up and function check, please see installation instructions.**
- **If the fan function or A/C control panel settings need to be checked, see the installation documentation in the additional 'Webasto Standard' or 'Webasto Comfort' A/C control kit, section 'Final Work'.**
- **Place the 'Switch off parking heater before refuelling' caution label near the filler point.**





FuelFix template for TSI

Top view

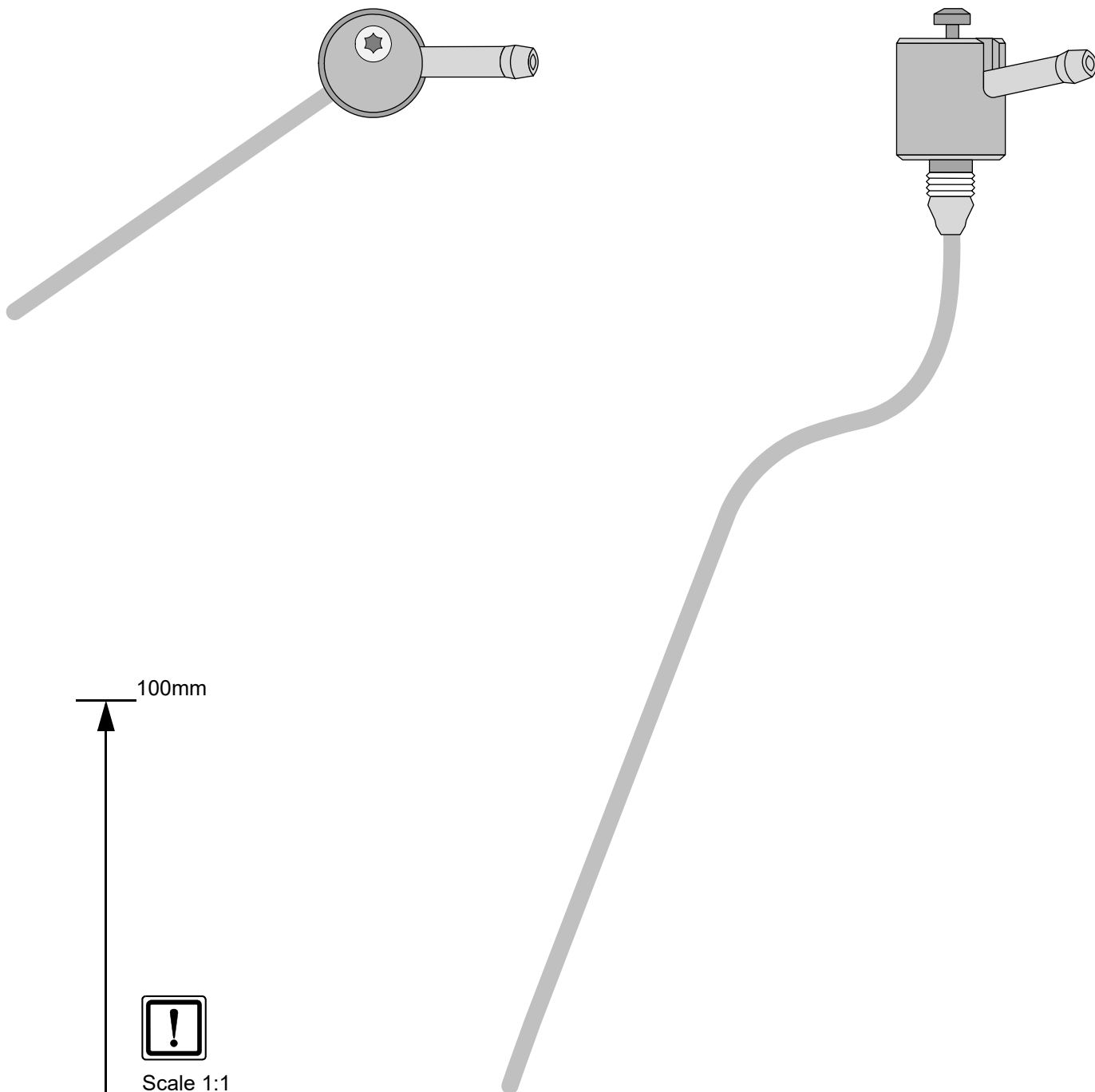

100mm



Scale 1:1

Compare size of printout with dimension lines.
Maximum permitted tolerance 2%.

Set the printer settings to 'no margin' or 'minimise margins' and 100% of the normal size.

100mm

0



FuelFix template for TDI Golf VII/ Sportsvan/ Superb 4x4

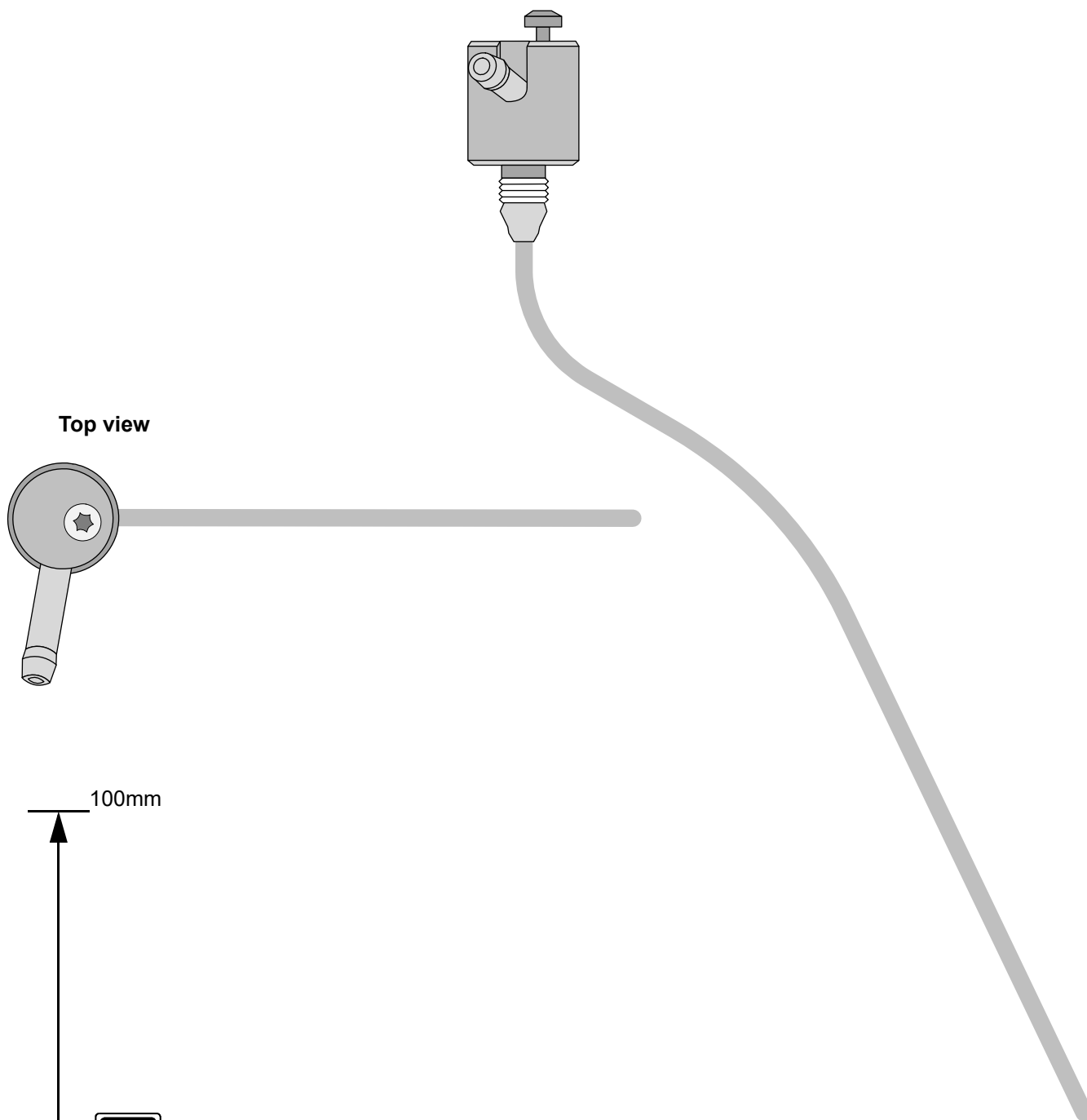

Top view

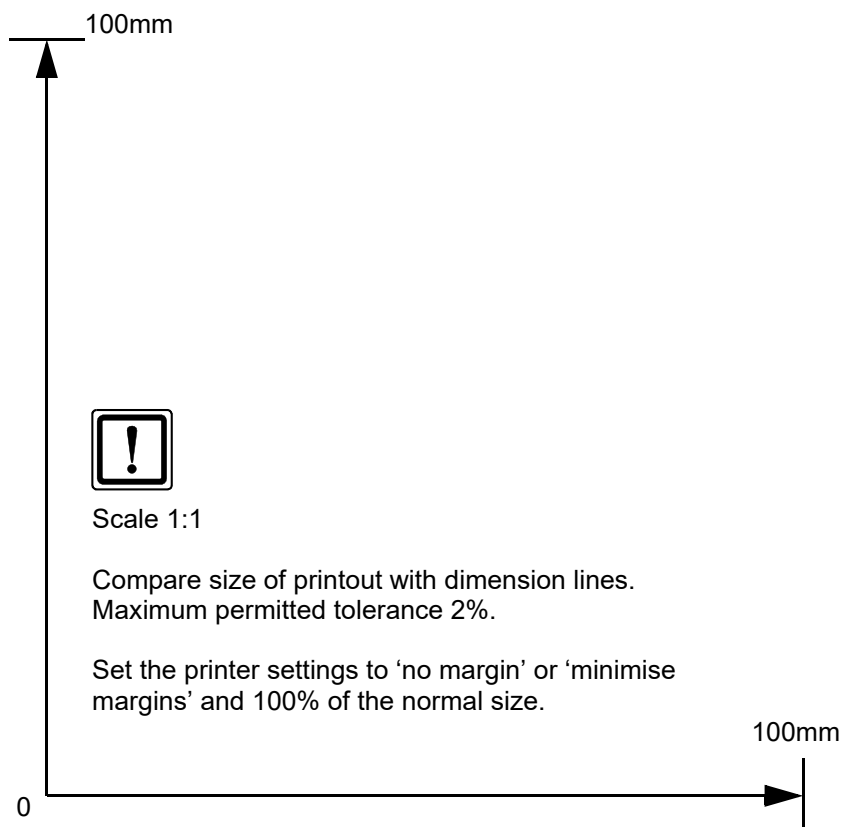

Scale 1:1

Compare size of printout with dimension lines.
Maximum permitted tolerance 2%.

Set the printer settings to 'no margin' or 'minimise margins' and 100% of the normal size.



FuelFix template for TDI Passat / Superb front-wheel drive

Top view

