



Water Heater

Thermo Top Evo Parking Heater



Installation Documentation VW Tiguan

Validity

Manufacturer	Model	Type	Model year	EG BE No. / ABE
VW	Tiguan	AD1	From model year 2016	e1 * 2001 / 116 * 0450 * ...

Motorisation	Fuel	Emission standard	Transmission type	Output in kW	Displacement in cm ³	Engine code
2.0 TDI	Diesel	Euro 6	6-speed SG	110	1968	DFGA
2.0 TDI	Diesel	Euro 6	DSG	110	1968	DFGA
2.0 TDI	Diesel	Euro 6	DSG	140	1968	DFHA
1.4 TSI	Petrol	Euro 6	6-speed SG	92	1395	CZCA
2.0 TSI	Petrol	Euro 6	DKG	132	1984	CZPA

SG = manual transmission
 DSG = direct gear transmission
 DKG = dual clutch transmission

Left-hand drive vehicle

Verified equipment variants: Climatic
 Climatronic
 LED main headlights
 Headlight washer system
 Halogen front fog lights
 LED daytime running lights
 Adaptive and dynamic cornering light
 Passenger compartment monitoring
 Start button / Keyless Entry
 2WD (diesel)
 4Motion (diesel and petrol)

Not verified: Xenon main headlights
 Alarm system

Total installation time: approx. 8.5 hours

VW Tiguan

Table of Contents

Validity	1	Preparing Installation Location	11
Necessary Components	2	Preparing Heater	12
Installation Instructions	2	Installing Heater	15
Information on Total Installation Time	2	Fuel	17
Information on Operating and Installation Instructions	3	Installing FuelFix	20
Information on Validity	4	Preparing Hose Routing	34
Technical Information	4	Coolant Circuit for 2WD Diesel Vehicles	36
Explanatory Notes on Document	4	Coolant Circuit for 4Motion Diesel Vehicles	39
Preliminary Work	5	Coolant Circuit for 2WD Petrol Vehicles	43
Heater Installation Location	5	Coolant Circuit for 4Motion Petrol Vehicles	46
Preparing Electrical System	6	Final Work	50
Electrical System	8	FuelFix Template for 2WD Diesel Vehicles	51
Air-Conditioning Control	9	FuelFix Template for 4Motion Diesel Vehicles	52
Heater Control	9	FuelFix Template for 2WD Petrol Vehicles	53
MultiControl CAR Option	9	FuelFix Template for 4Motion Petrol Vehicles	54
Remote Option (Telestart)	9		
ThermoCall Option	10		

Necessary Components

Description	Order No.:
Basic delivery scope of Thermo Top Evo	In accordance with price list
Installation kit with FuelFix for VW Tiguan 2016 petrol and diesel	1325134A
Additional 'Webasto Standard' A/C control kit for VW / Skoda / Seat MQB Climatic and Climatronic or Additional 'Webasto Comfort' A/C control kit for VW / Skoda / Seat MQB Climatronic	1325085_ 1325012_
In case of Telestart, heater control, as well as indicator lamp in consultation with end customer	In accordance with price list
In case of installation of MultiControl CAR - MultiControl installation frame	9030077_

Installation Instructions

Arrange for the vehicle to be delivered with the tank only about ¼ full.

The installation location of the push button in case of Telestart or ThermoCall should be confirmed with the end customer.

Depending on the space required and the vehicle manufacturer's instructions, we recommend the use of a vehicle battery with a higher electrical capacity.

Information on Total Installation Time

The total installation time includes the time needed for mounting and demounting the vehicle-specific components, the heater specific installation time and all other times required for the system integration and initial start-up of the heater.

The total installation time may vary for vehicle equipment other than provided.

Information on Operating and Installation Instructions

1 Important information (not complete)

1.1 Installation and repair



The improper installation or repair of Webasto heating and cooling systems can cause fire or the leakage of deadly carbon monoxide, leading to serious injury or death.



To install and repair Webasto heating and cooling systems you need to have completed a special company training course and have the appropriate technical documentation, special tools and special equipment.



Installation and repair may ONLY be carried out by persons trained and certified in a Webasto training course. NEVER try to install or repair Webasto heating or cooling systems if you have not completed a Webasto training course, you do not have the necessary technical skills and you do not have the technical documentation, tools and equipment available to ensure that you can complete the installation and repair work properly.

Only use genuine Webasto parts. See the Webasto air and water heaters accessories catalogue for this purpose.

1.2 Operation

To ensure safe operation, we recommend having the heater checked every two years by an authorised Webasto dealer, especially when used over a long period and/or under extreme environmental conditions.

Do not operate the heater in closed rooms due to the danger of poisoning and suffocation.

Always switch off the heater before refuelling.

The heater may only be used with the prescribed fuel diesel (DIN EN 590) or petrol (DIN EN 228).

The heater may not be cleaned with a high-pressure cleaner.

1.3 Please note

ALWAYS follow all Webasto installation and operating instructions and observe all warnings.

To become familiar with and understand all functions and properties of the heater, the operating instructions must be read carefully and observed at all times.

For proper, safe installation and repair work, the installation instructions with all warnings and safety information must be carefully read and observed at all times. Please always contact a workshop authorised by Webasto for all installation and repair work.

Important

Webasto shall assume no liability for defects, damage and injuries resulting from a failure to observe the installation, repair and operating instructions of the information contained in them.

This liability exclusion particularly applies to improper installations and repairs, installations and repairs by untrained persons or in the case of a failure to use genuine spare parts.

The liability due to culpable disregard to life, limb or health and due to damage or injuries caused by a wilful or reckless breach of duty remain unaffected, as does the obligatory product liability.

Installation should be carried out according to the general, standard rules of technology. Unless specified otherwise, fasten hoses, lines and wiring harnesses to original vehicle lines and wiring harnesses using cable ties. Insulate loose wire ends and tie back. Connectors on electronic components must audibly snap into place during assembly.

Sharp edges should be fitted with rub protection. Spray unfinished body areas, e.g. drilled holes, with anti-corrosion wax (Tectyl 100K).

Observe the instructions and guidelines of the respective vehicle manufacturer for demounting and mounting vehicle specific components!

The initial start-up is to be executed with the Webasto Thermo Test Diagnosis.

When installing a programmable control module (e.g. a PWM Gateway), the corresponding settings must be checked or adjusted.

2 Statutory regulations governing installation

Guidelines	Thermo Top Evo
Heating Directive ECE R122	E1 00 0258
EMC Directive ECE R10	E1 04 5627

Note

The regulations of these guidelines are binding in the scope of the Directive 70/156/EEC and/or 2007/46/EC (for new vehicle models from 29/04/2009) and should also be observed in countries in which there are no special regulations.

Important

Failure to follow the installation instructions will result in the invalidation of the type approval for the heater and therefore invalidation of the general **homologation of the vehicle**.

Note

The heater is licensed in accordance with paragraph 19, section 3, No. 2b of the StVZO (German Road Traffic Licensing Authority).

2.1 Excerpt from ECE regulation 122 (heating system) paragraph 5 for the installation of the heater

Beginning of excerpt.

ANNEX VII

REQUIREMENTS FOR COMBUSTION HEATERS AND THEIR INSTALLATION

1. GENERAL REQUIREMENTS

1.7.1. A clearly visible tell-tale in the operator's field of view shall inform when the combustion heater is switched on or off.

2. VEHICLE INSTALLATION REQUIREMENTS

2.1. Scope

2.1.1. Subject to paragraph 2.1.2, combustion heaters shall be installed according to the requirements of this Annex.

2.1.2. Vehicles of category O having liquid fuel heaters are deemed to comply with the requirements of this Annex.

2.2. Positioning of heater

2.2.1. Body sections and any other components in the vicinity of the heater must be protected from excessive heat and the possibility of fuel or oil contamination.

2.2.2. The combustion heater shall not constitute a risk of fire, even in the case of overheating. This requirement shall be deemed to be fulfilled if the installation ensures an adequate distance to all parts and suitable ventilation, by the use of fire resistant materials or by the use of heat shields.

2.2.3. In the case of M2 and M3 vehicles, the heater must not be positioned in the passenger compartment. However, an installation in an effectively sealed envelope which also complies with the conditions in paragraph 2.2.2 may be used.

2.2.4. The label referred to in paragraph 1.4 or a duplicate, must be positioned so that it can be easily read when the heater is installed in the vehicle.

2.2.5. Every reasonable precaution should be taken in positioning the heater to minimise the risk of injury and damage to personal property.

2.3. Fuel supply

2.3.1. The fuel filler must not be situated in the passenger compartment and must be provided with an effective cap to prevent fuel spillage.

2.3.2. In the case of liquid fuel heaters, where a supply separate to that of the vehicle is provided, the type of fuel and its filler point must be clearly labelled.

2.3.3. A notice, indicating that the heater must be shut down before refuelling, must be affixed to the fuelling point. In addition a suitable instruction must be included in the manufacturer's operating manual.

2.4. Exhaust system

2.4.1. The exhaust outlet must be located so as to prevent emissions from entering the vehicle through ventilators, heated air inlets or opening windows.

2.5. Combustion air inlet

2.5.1. The air for the combustion chamber of the heater must not be drawn from the passenger compartment of the vehicle.

2.5.2. The air inlet must be so positioned or guarded that blocking by rubbish or luggage is unlikely.

2.6. Heating air inlet

2.6.1. The heating air supply may be fresh or recirculated air and must be drawn from a clean area not likely to be contaminated by exhaust fumes emitted either by the propulsion engine, the combustion heater or any other vehicle source.

2.6.2. The inlet duct must be protected by mesh or other suitable means.

2.7. Heating air outlet

2.7.1. Any ducting used to route the hot air through the vehicle must be so positioned or protected that no injury or damage could be caused if it were to be touched.

2.7.2. The air outlet must be so positioned or guarded that blocking by rubbish or luggage is unlikely.

End of excerpt.

In multilingual versions the German language is binding.

VW Tiguan

Information on Validity

This installation documentation applies to VW Tiguan petrol and diesel vehicles - for validity, see page 1 - from model year 2016 and later, assuming technical modifications to the vehicle do not affect installation, any liability claims excluded. Depending on the vehicle version and equipment, modifications may be necessary during installation with respect to this installation documentation.

Vehicle and engine types, equipment variants and other specifications not listed in this installation documentation have not been tested. However, installation according to this installation documentation may be possible.

Technical Information

Special Tools

- Hose clamp pliers for auto-tightening hose clamps
- Hose clamp pliers for Clic hose clamps of type W
- Automatic wire stripper, 0.2 - 6mm²
- Crimping pliers for tab connector, 0.14 - 6mm²
- Crimping pliers for cable lug, 0.5 - 10mm²
- Crimping pliers for connector 0,25 - 6mm²
- Torque wrench for 2,0 - 10 Nm
- Hose clamping pliers
- Metric thread-setter kit
- Deep-hole marker
- Webasto Thermo Test Diagnosis with current software

Dimensions

- All dimensions are in mm.

Tightening torque values

- Tighten bolt connections in accordance with manufacturer's instructions or in accordance with state-of-the-art-technology.

Explanatory Notes on Document

You will find an identification mark on the outside top right corner of the page in question to provide you with a quick overview of the individual working steps.

Mechanics



Electrics



Coolant Circuit



Combustion Air

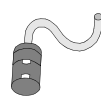

Fuel



Exhaust Gas



Software



Special features are highlighted using the following symbols:

Specific risk of damage to components.



Specific risk due to electrical voltage.



Specific risk of fire or explosion.



Reference to a special technical feature.



The arrow in the vehicle icon indicates the position on the vehicle and the viewing angle.

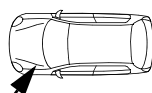

Reference to the manufacturer's vehicle-specific documents.



Reference to specific installation instructions of Webasto components (demonstrated with the example of the FuelFix).



Reference to general installation instructions of Webasto components.



Tightening torque according to the manufacturer's vehicle-specific documents.



VW Tiguan

Preliminary Work

Vehicle

- Open the fuel tank cap.
- Ventilate the fuel tank.
- Close the fuel tank cap again.
- Depressurise the cooling system.
- Disconnect and remove the battery completely together with the carrier.
- Remove the air filter box completely with the intake hose (not for 1.4 TSI).
- Remove the engine underdrive protection.
- Remove the right underdrive protection.
- Remove the fuel tank underdrive protection, if present.
- Remove the right front wheel.
- Remove the front right wheel well trim.
- Remove the lateral instrument panel trim on the driver's side (in case of Telestart).
- Remove the A-pillar trim on the driver's side (in case of Telestart).
- Remove the rear bench seat.
- Open the right-hand tank-fitting service lid.

Heater

- Remove years that do not apply from the type and duplicate label.
- Attach the duplicate label (type label) visibly in the appropriate place in the engine compartment.

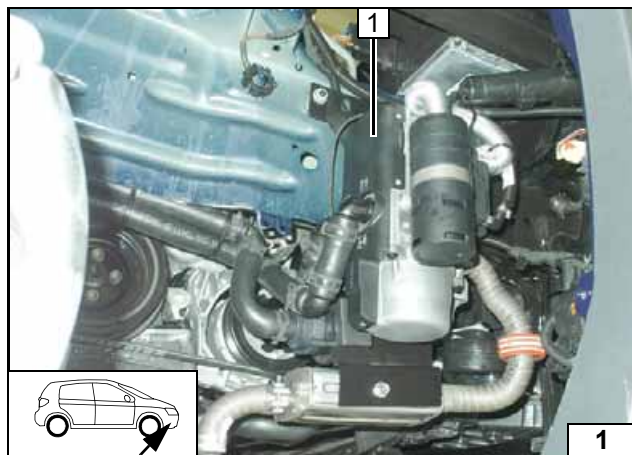

Heater Installation Location

- 1 Heater

Installation location



Preparing Electrical System



Installation overview

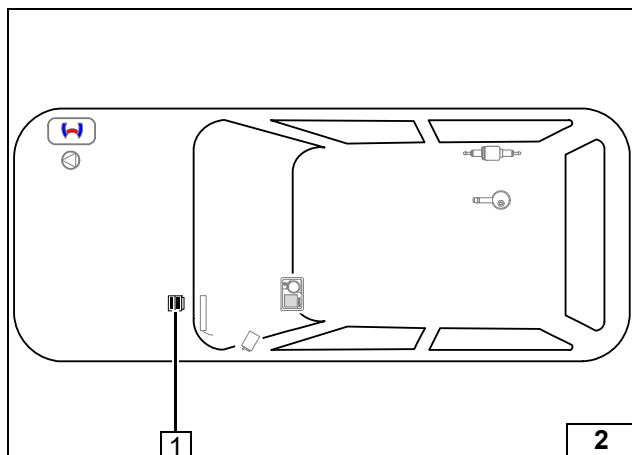

1 Engine compartment fuse holder

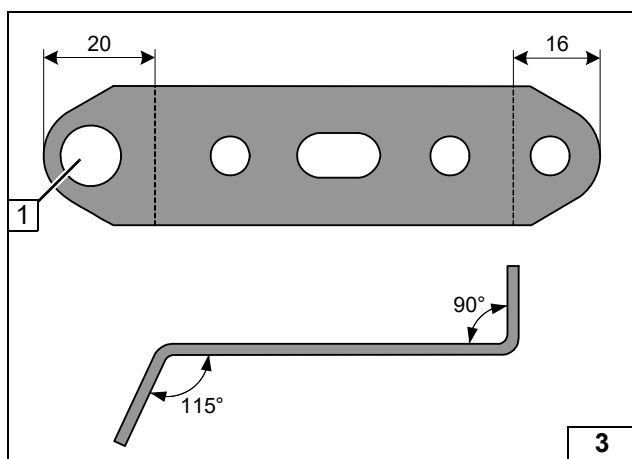

1 12.5mm dia. hole

Preparing perforated bracket

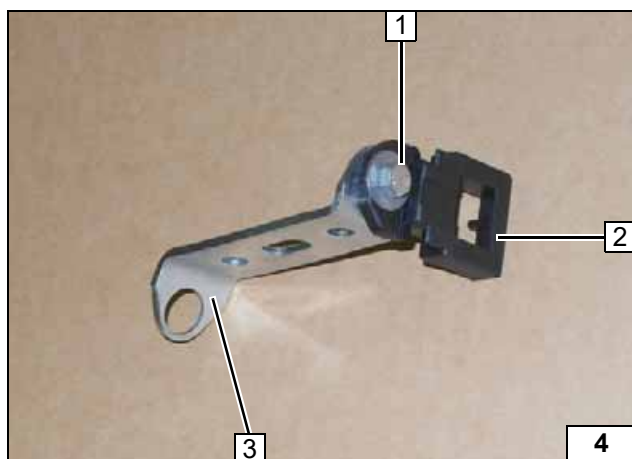

- 1 M5x16 bolt, washer [2x], nut
- 2 Fuse holder retaining plate
- 3 Perforated bracket

Premounting engine compartment fuse holder

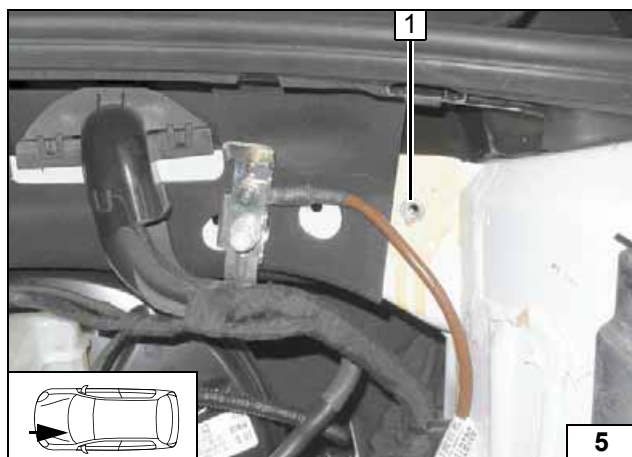

1 Drill out existing hole to 9 mm dia., rivet nut

Installing rivet nut

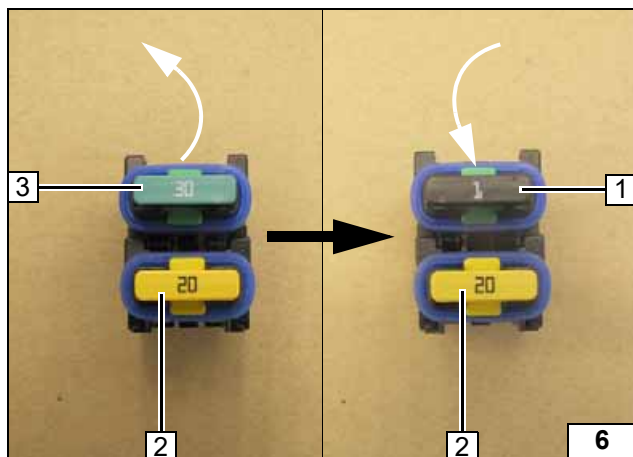

Replace passenger compartment 30A main fuse F2 **3** with 1A fuse **1**.

2 20A heater fuse F1

Preparing engine compartment fuses

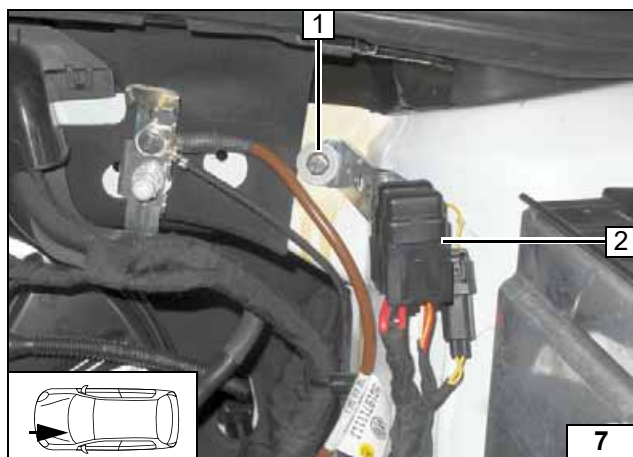

1 M6x20 bolt, spring lockwasher, large diameter washer

2 Fuses F1-2

Installing engine compartment fuse holder

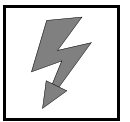

Electrical System



Wiring harness routing

Route heater wiring harness below the cover along the marking to the installation location of the heater and fasten using retaining clamp 1 [3x].

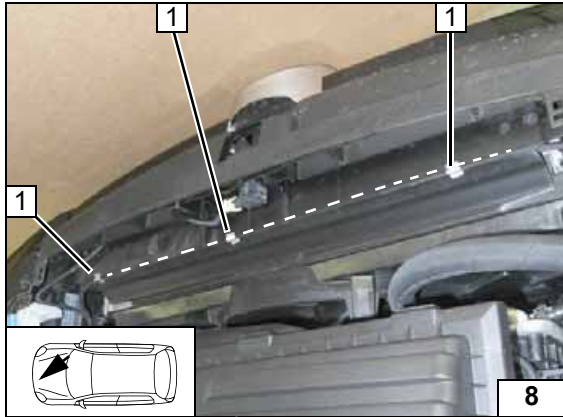

Earth wire

1 Earth wire on earth support point

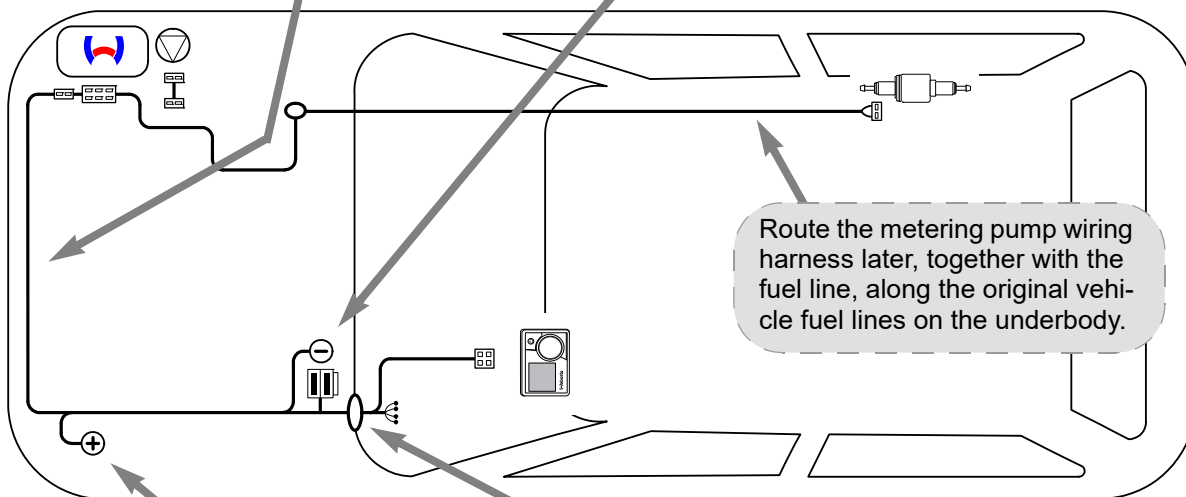
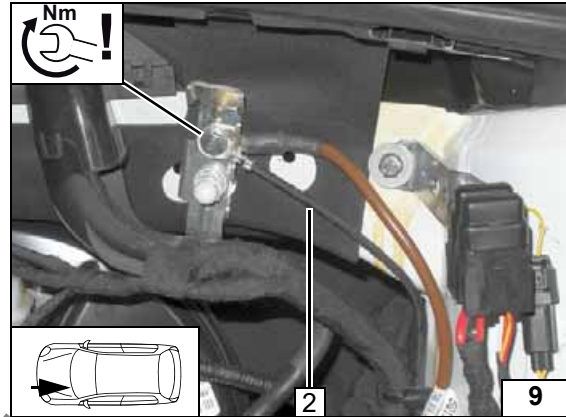

Wiring harness routing diagram

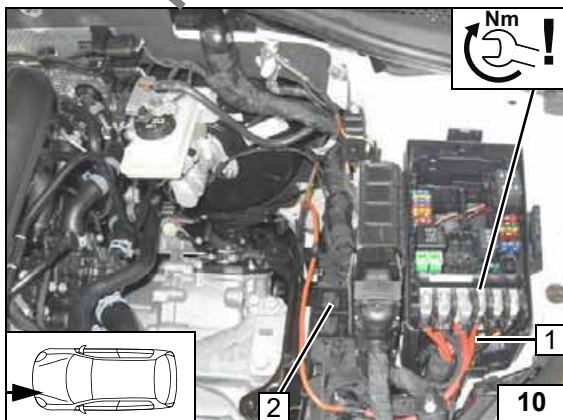

Positive wire

- 1 Positive wire on positive distributor
- 2 Wiring harnesses in original vehicle line duct

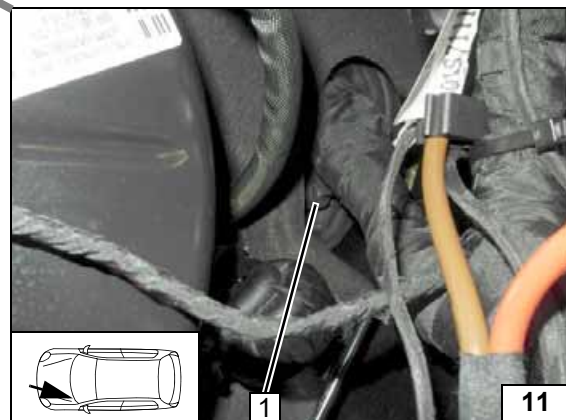

Wiring harness pass through

Route heater wiring harnesses and heater control through protective rubber plug 1 to the passenger compartment.



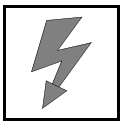

Air-Conditioning Control

! Integrate the A/C control as explained in the separate installation documentation:

Installation documentation of '**Webasto Standard**' A/C control for VW / Skoda / Seat AAC

or

Installation documentation of '**Webasto Comfort**' A/C control for VW / Skoda / Seat AAC

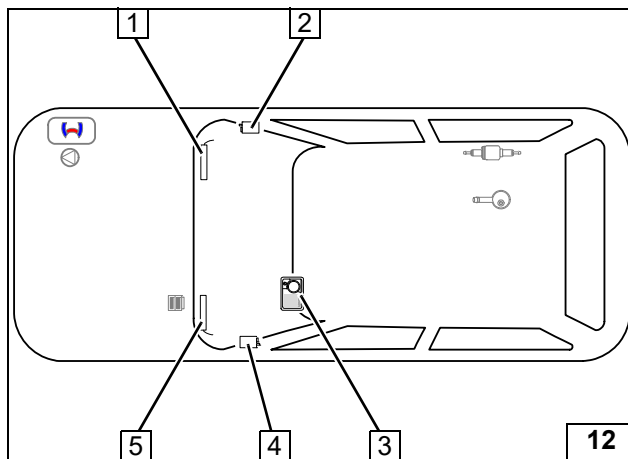

Heater Control

- 1 ThermoCall aerial
- 2 ThermoCall
- 3 MultiControl CAR
- 4 Telestart receiver
- 5 Telestart aerial



Installation overview

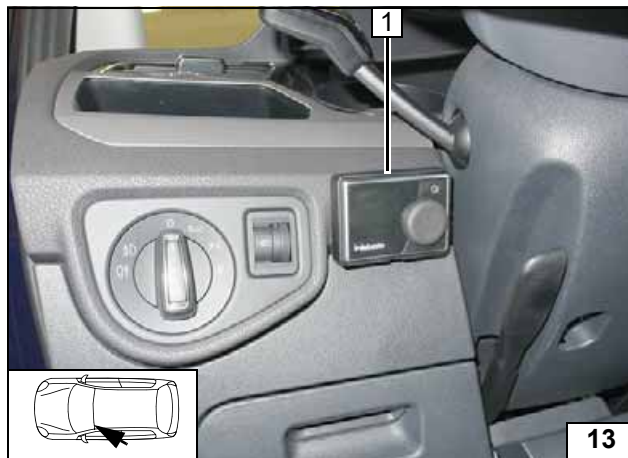

MultiControl CAR Option

- 1 Installation frame



Installing MultiControl CAR

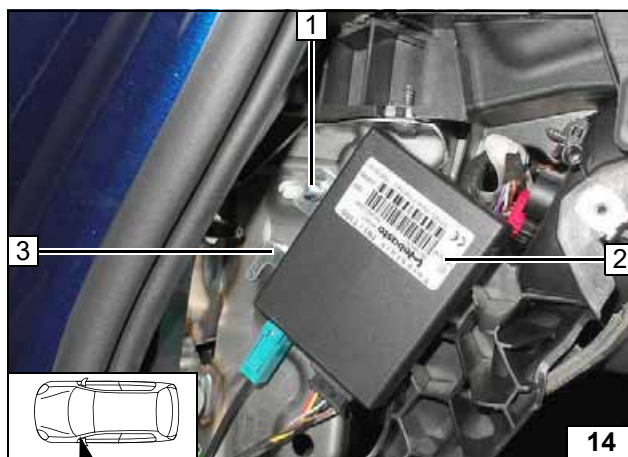

Remote Option (Telestart)

- 1 M5x16 bolt, large diameter washer, nut, existing hole
- 2 Receiver
- 3 Bracket of receiver



Installing receiver

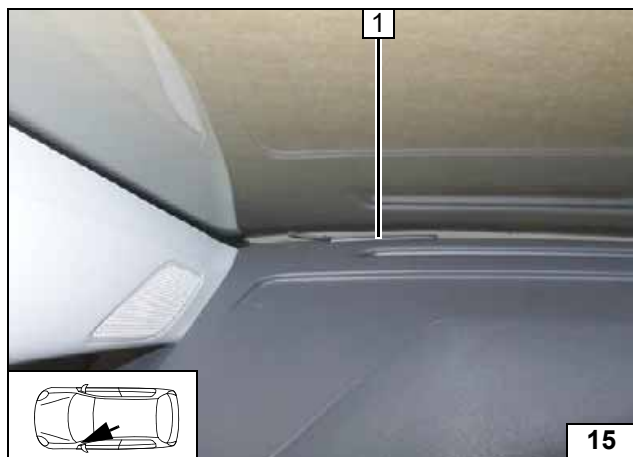

1 Aerial

Installing aerial



Temperature sensor T100 HTM

Fasten temperature sensor 1 with double-sided adhesive tape.



Installing temperature sensor



ThermoCall Option

Fasten receiver 1 with double-sided adhesive tape.



Installing receiver

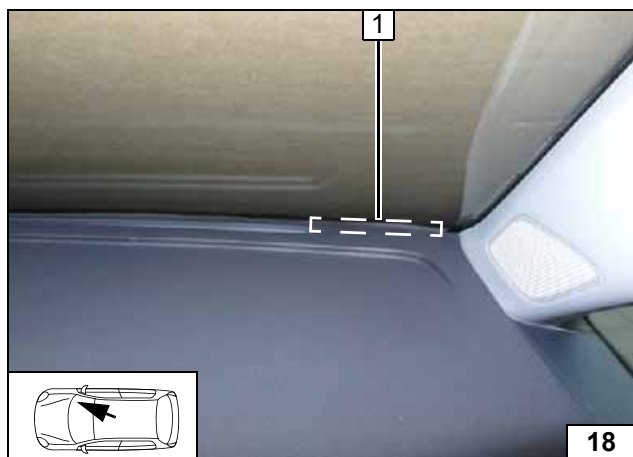

1 Aerial (optional)

Installing aerial

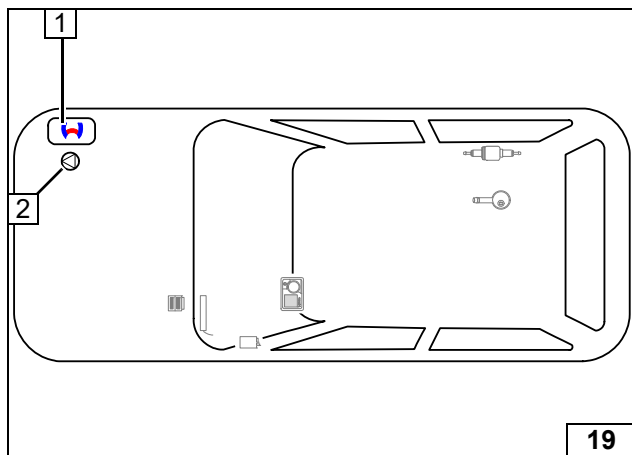

Preparing Installation Location

- 1 Heater
- 2 Circulating pump



Installation overview

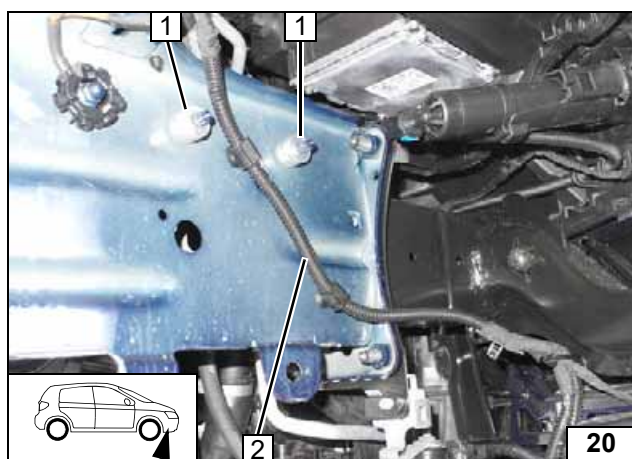

- 1 8mm spacer, 5mm spacer [2x each]
- 2 Detach wiring harness

Positioning spacer

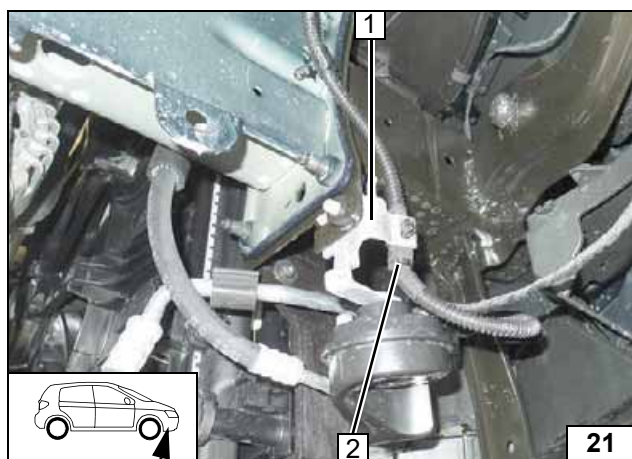

Bend bracket 1 as shown. Fastening wiring harness 2.



Bending horn bracket

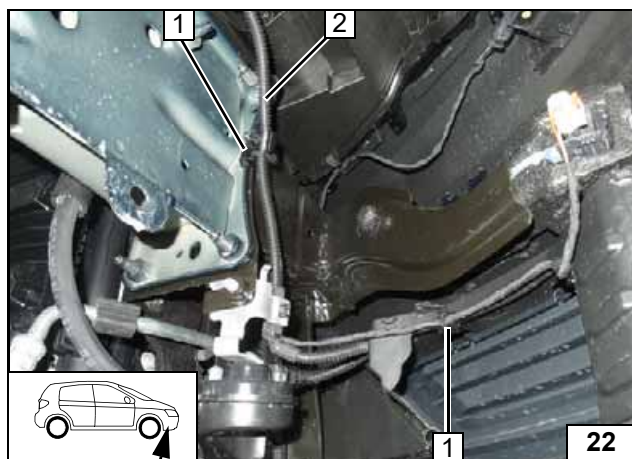

Fasten wiring harness 2 with edge clip cable tie 1 [2x].



Aligning wiring harness

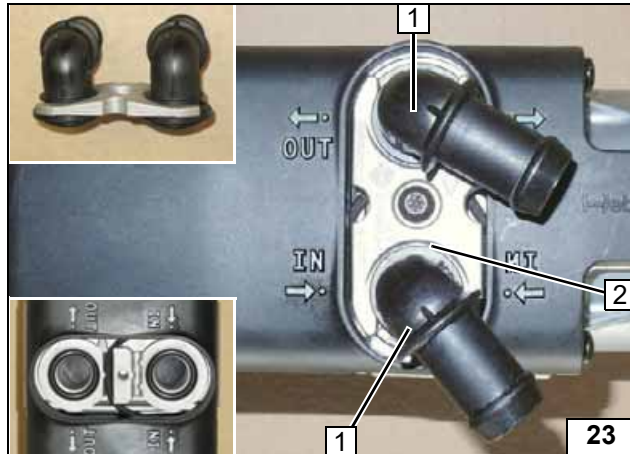
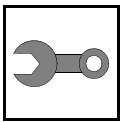

Preparing Heater

- 1 Water connection piece, sealing ring [2x each]
- 2 5x15 self-tapping bolt, retaining plate of water connection piece



Installing water connection piece

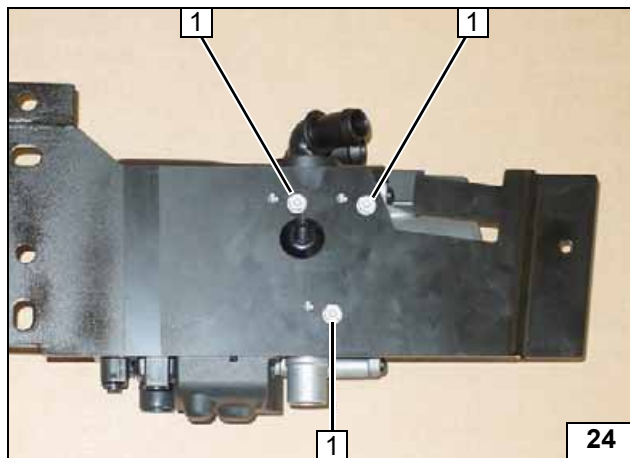

Use hole pattern as shown.

- 1 5x13 self-tapping bolt [3x]



Installing bracket

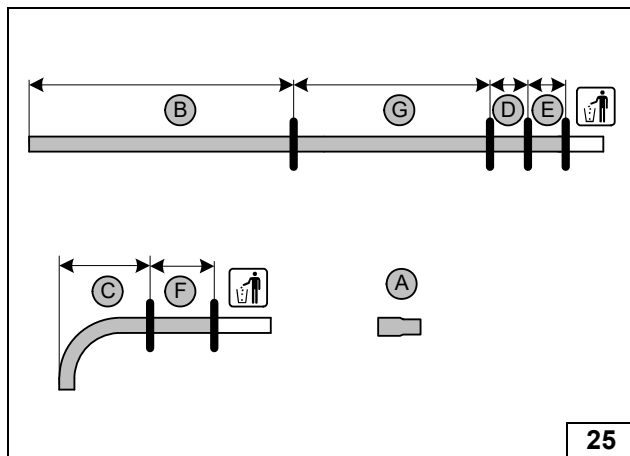

2WD Diesel

Hose **A** = 18x20 mm dia., straight moulded hose

- B** = 1020
- C** = 110
- D** = 85
- E** = 85
- F** = 110
- G** = 980



Cutting hoses to length

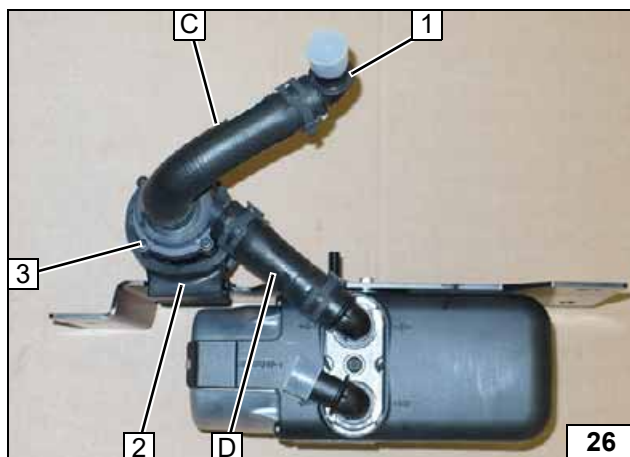

All spring clips = 25 mm dia.
Push mount of circulating pump **2** onto tab of bracket.

- 1 90° connecting pipe
- 3 Circulating pump



Premounting hoses

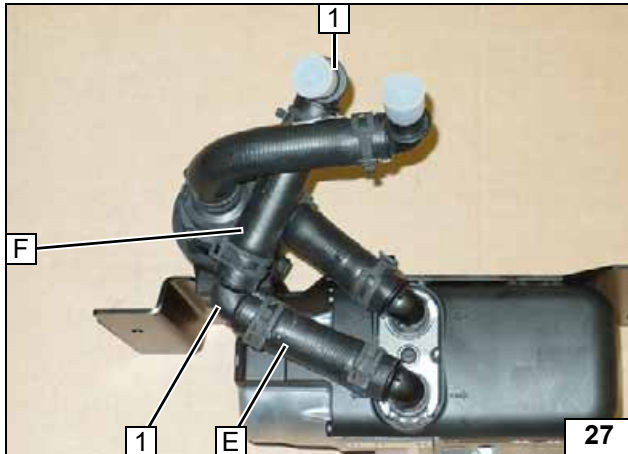
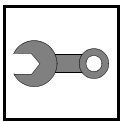

All spring clips = 25 mm dia.

- 1 90° connecting pipe [2x]



Premounting hoses

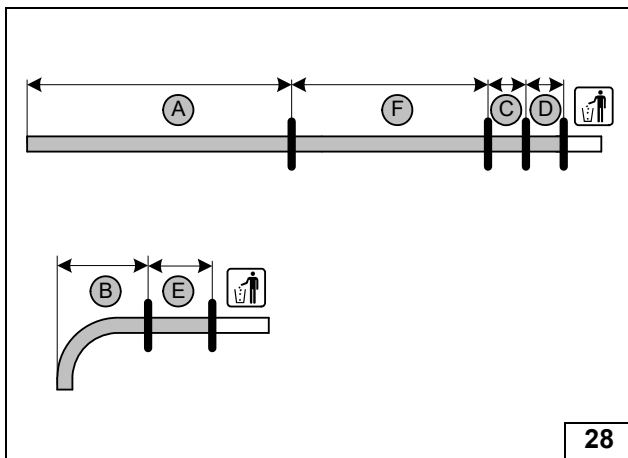

4Motion and petrol 2WD

	Diesel	Petrol	Petrol
	4Motion	4Motion	2WD
A	850	930	1070
B	110	110	110
C	70	70	85
D	70	70	90
E	110	110	110
F	900	960	990

Cutting hoses to length

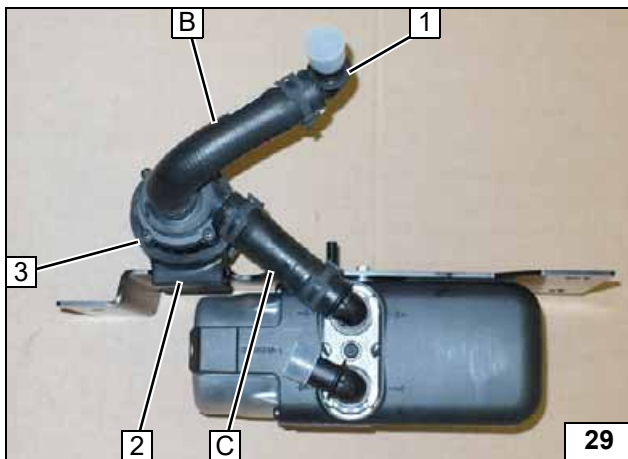

All spring clips = 25 mm dia.

Push mount of circulating pump 2 onto tab of bracket.

- 1 90° connecting pipe
- 3 Circulating pump



Premounting hoses

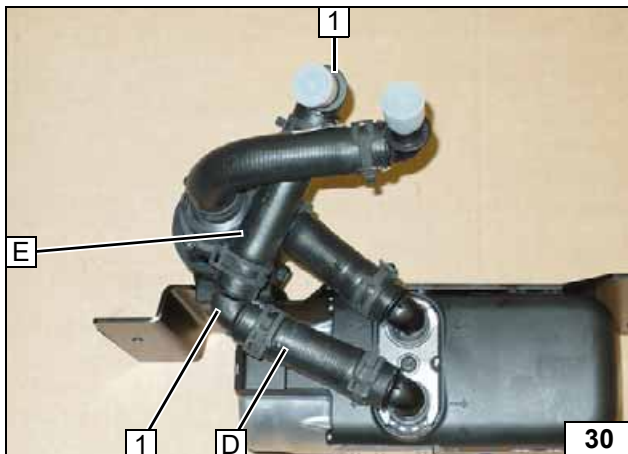

All spring clips = 25 mm dia.

- 1 90° connecting pipe [2x]



Premounting hoses

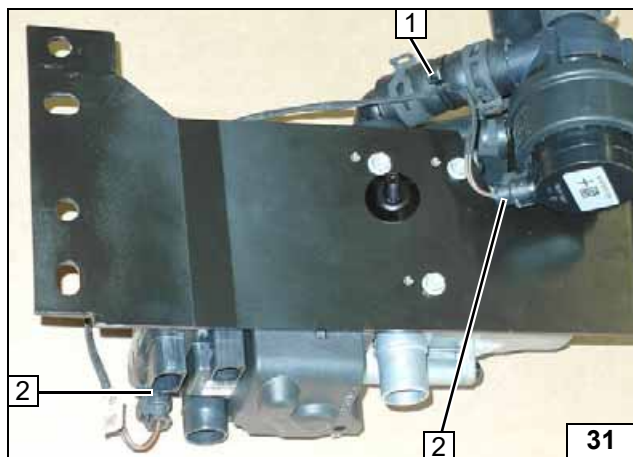

All vehicles

- 1 Cable tie
- 2 Connector of circulating pump wiring harness [2x]

**Connect-
ing wiring
harness**

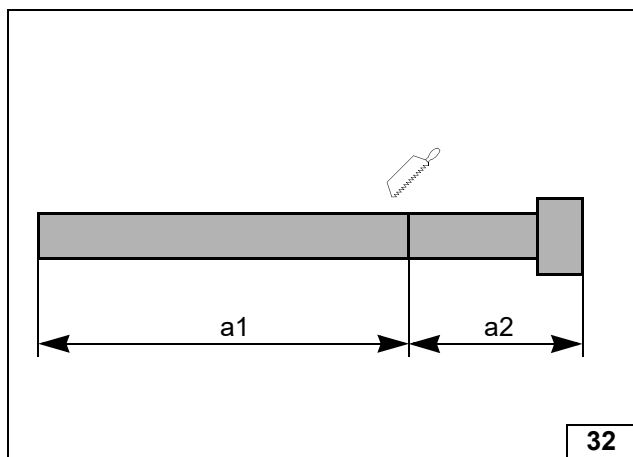

- a1 = 300
- a2 = 100

**Preparing ex-
haust pipe**

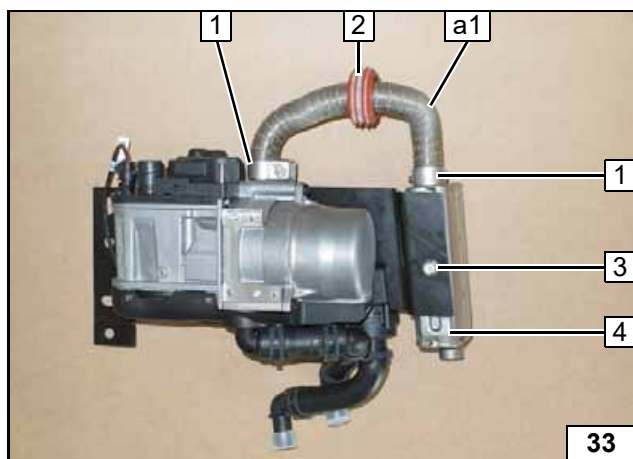

- 1 Hose clamp [2x]
- 2 Spacer bracket
- 3 M6x16 bolt with serrated flange
- 4 Silencer

**Installing
exhaust
pipe a1 and
silencer**



**Aligning
exhaust
pipe a1**

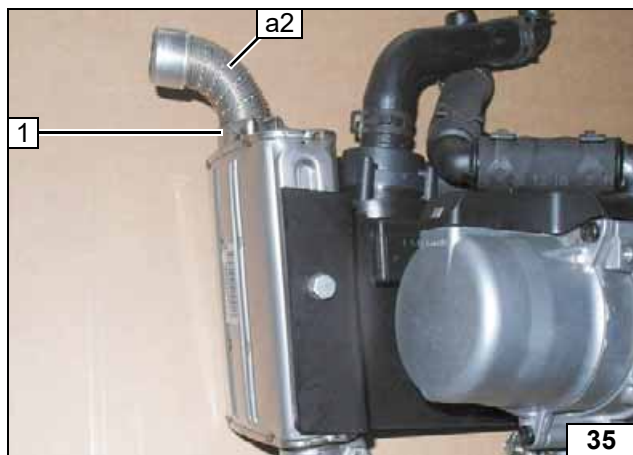

1 Hose clamp

Installing exhaust pipe a2

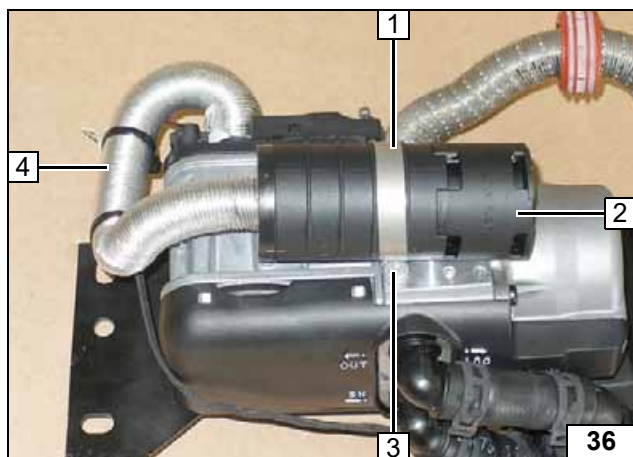

1 51mm dia. clamp
2 Combustion air silencer
3 5x13 self-tapping bolt
4 Combustion air pipe



Installing combustion air pipe / combustion air silencer

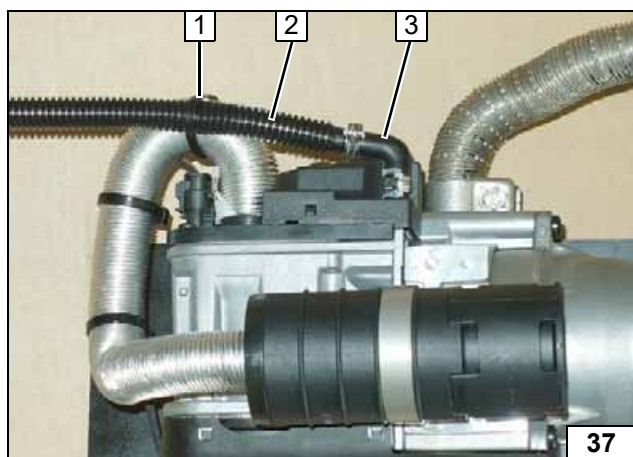

1 Cable tie
2 Fuel line in 200mm long corrugated tube
3 90° short moulded hose, 10 mm dia. clamp [2x]



Premounting fuel line

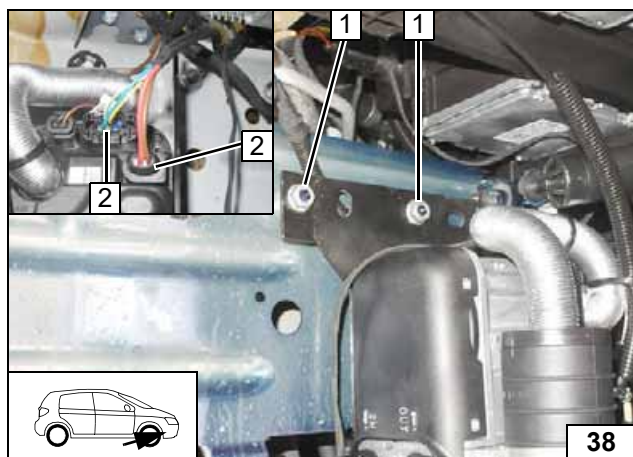

Installing Heater

Insert connector of heater wiring harness 2 [2x] before installing the heater!

1 Original vehicle stud bolt, 5mm shim, 8mm shim, M8 flanged nut [2x each]



Installing heater



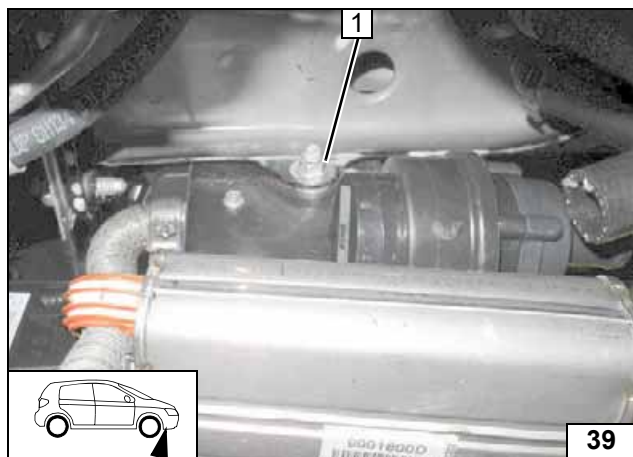
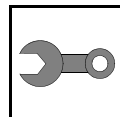

Position one 5mm spacer between bracket and eyelet at position 1.



- 1 Stud bolt of heater, 5mm spacer, large diameter washer, flanged nut

Installing heater



Ensure sufficient distance between exhaust pipe **a1** and horn as well as original vehicle wiring harnesses, correct if necessary!



- 1 Position spacer bracket

Aligning exhaust pipe a1



Ensure sufficient distance between exhaust pipe **a1** and original vehicle wiring harnesses, correct if necessary!



Aligning exhaust pipe a1

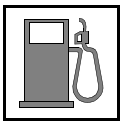

Fuel



Open the vehicle's fuel tank cap, ventilate the tank and then re-close the tank lock.

Catch any fuel running off in an appropriate container.

Route fuel line and metering pump wiring harness so that they are protected against stone impact. Unless specified otherwise, always fasten using cable ties.



Provide rub protection for fuel line and wiring harness in areas where there are sharp edges.

The fuel line and wiring harness are routed to the metering pump as shown in the wiring harness routing diagram.

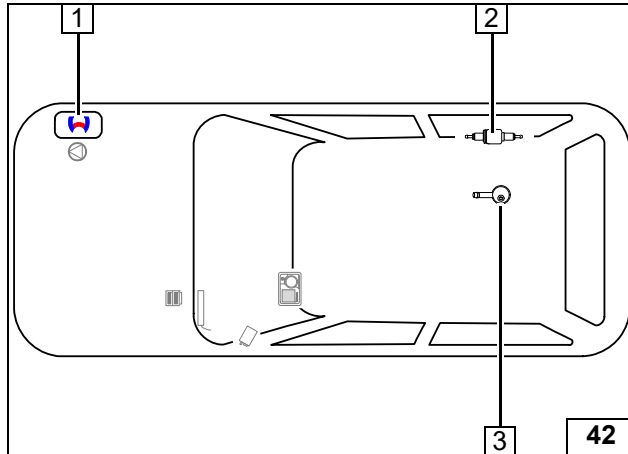

- 1 Heater assembly
- 2 Metering pump
- 3 FuelFix



Installation overview

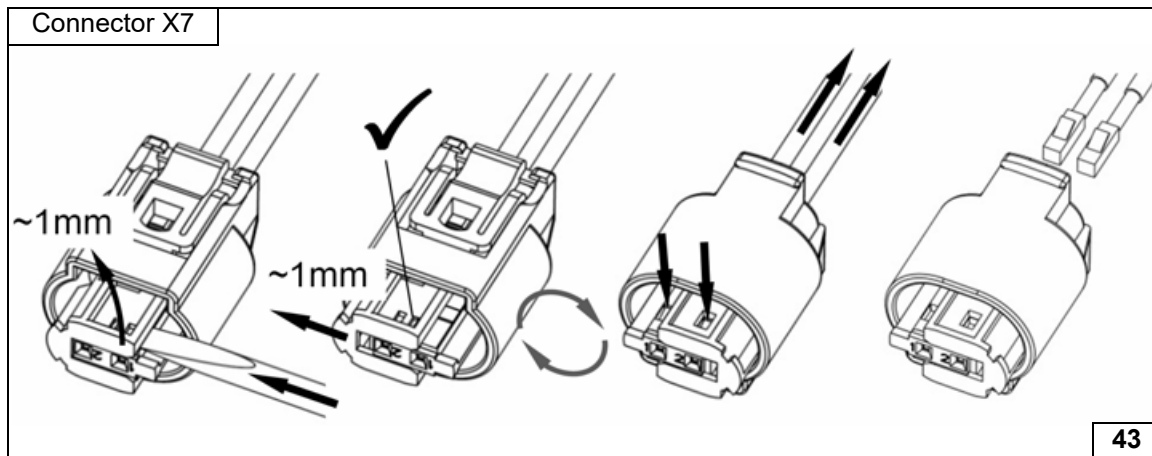

Dismantling metering pump connector

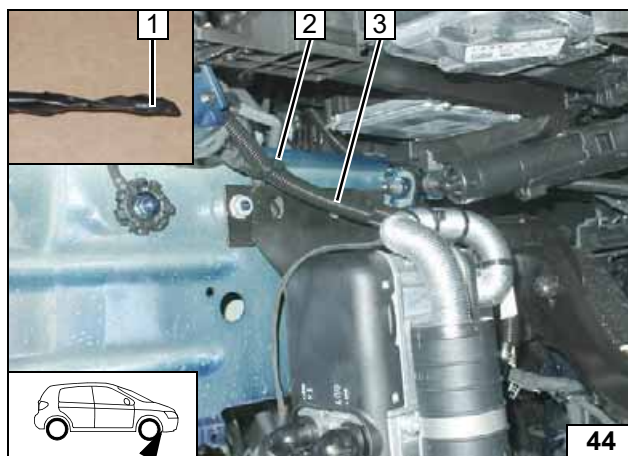

Close the opening of the fuel line 1 with insulating tape.

Pull fuel line and wiring harness of metering pump into 10mm dia. corrugated tube 3 and route in the engine compartment.



Routing lines

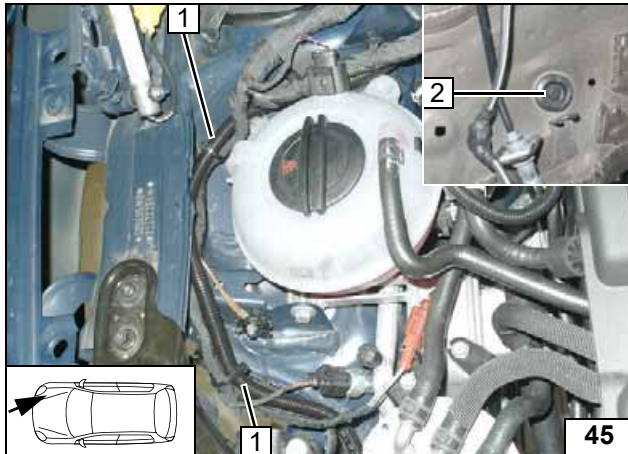

Route fuel line and wiring harness of metering pump in 10mm dia. corrugated tube 1 to original vehicle grommet 2 in the wheel well.



Routing lines

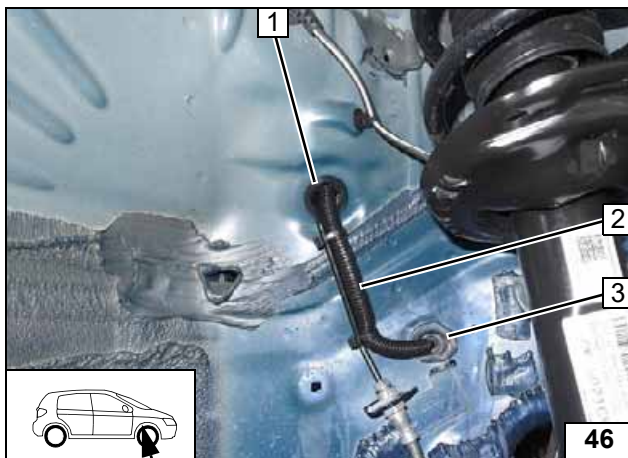

- 1 Original vehicle grommet in wheel well
- 2 Fuel line and wiring harness of metering pump in 10mm dia. corrugated tube
- 3 Original vehicle pass through grommet in underbody

Routing lines

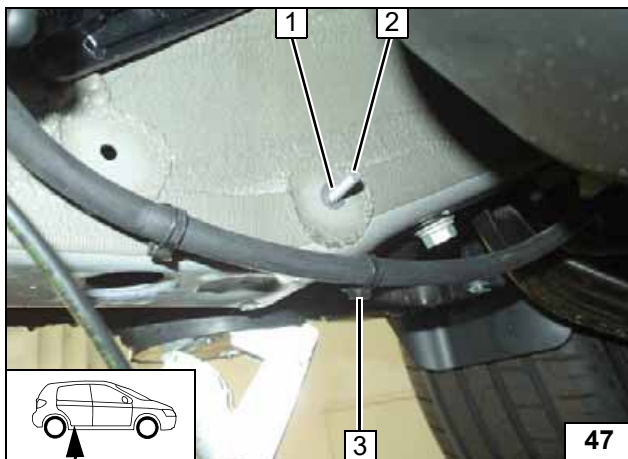

Remove handbrake cable clip 3 at position 1 and discard, insert M6x25 bolt 2 by appropriate means through hole 1 and secure using a lock washer.



Premounting M6x25 bolt

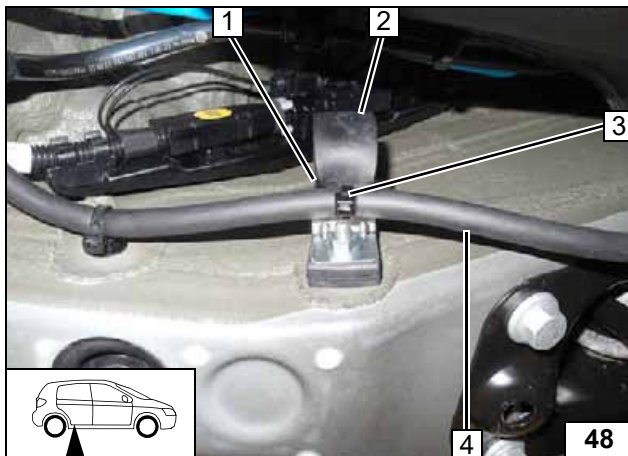

Attach handbrake cable 4 using cable ties 1 and 3 to support angle bracket.



- 2 Metering pump mount

Installing metering pump mount

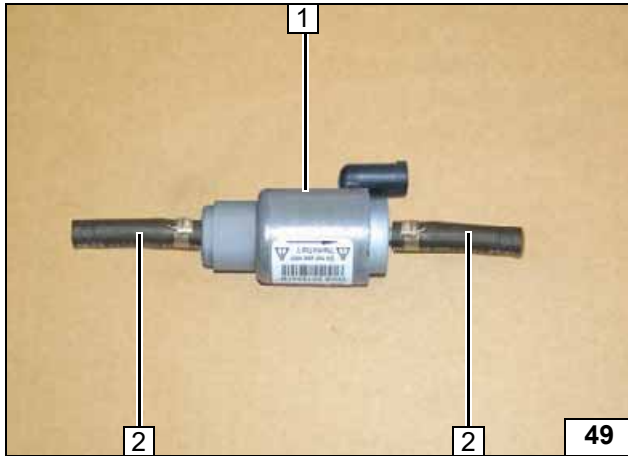

- 1 Metering pump
- 2 Hose section, 10mm dia clamp [2x each]

Premounting metering pump

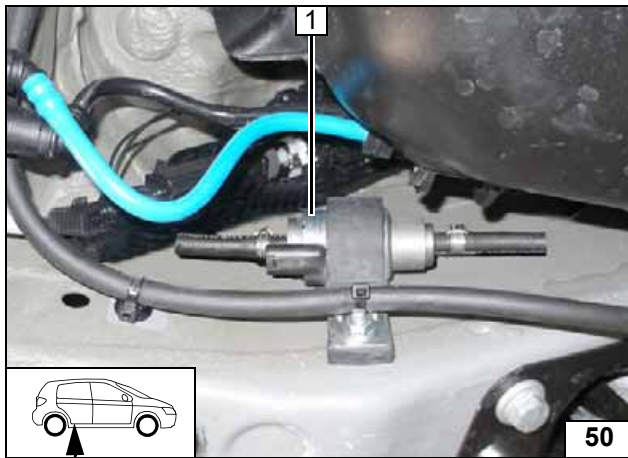

- 1 Metering pump



Installing metering pump

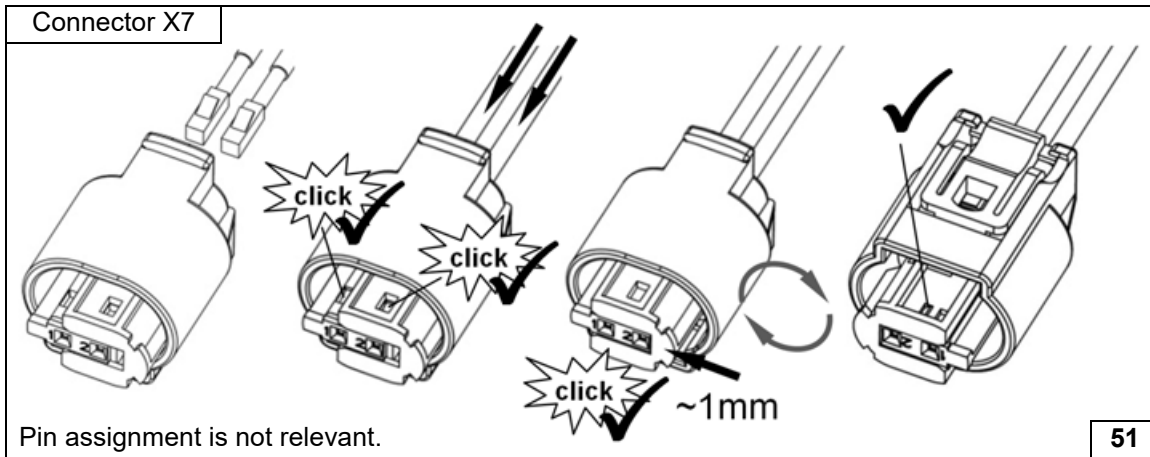

Pin assignment is not relevant.

51

Completing metering pump connector

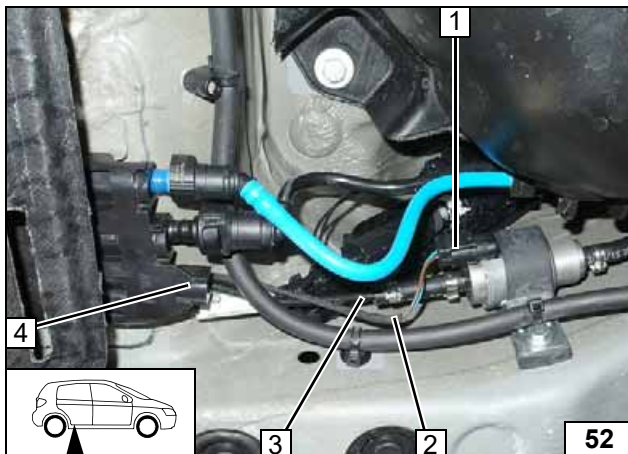

- 1 Metering pump wiring harness, connector X7 mounted
- 2 Fuel line of heater
- 3 10 mm dia. clamp
- 4 Underbody pass through



Connecting metering pump

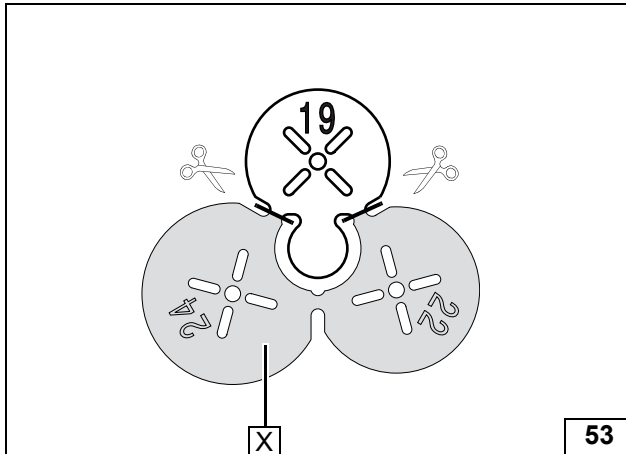

Installing FuelFix

2WD Diesel

X =



Preparing drilling template

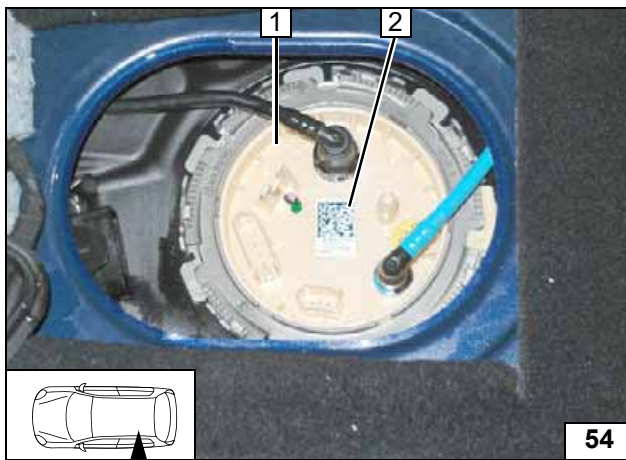

Work step F1.

Detach sticker 2.

- 1 Fuel tank sending unit



Moving sticker

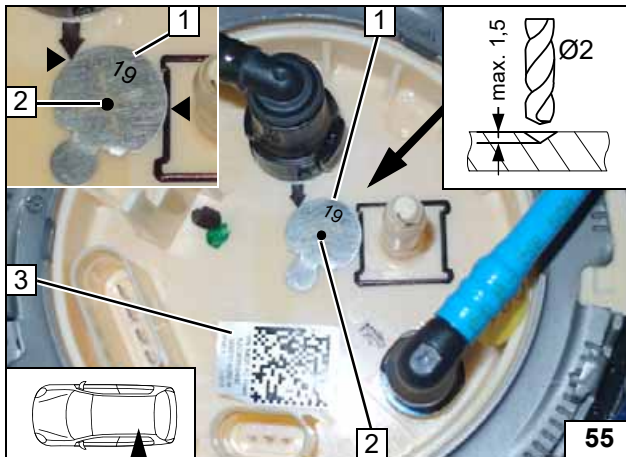

Work step F2.

- 1 Position 19mm dia. drilling template as shown
- 2 2mm dia. centring hole
- 3 Position sticker



Copying hole pattern

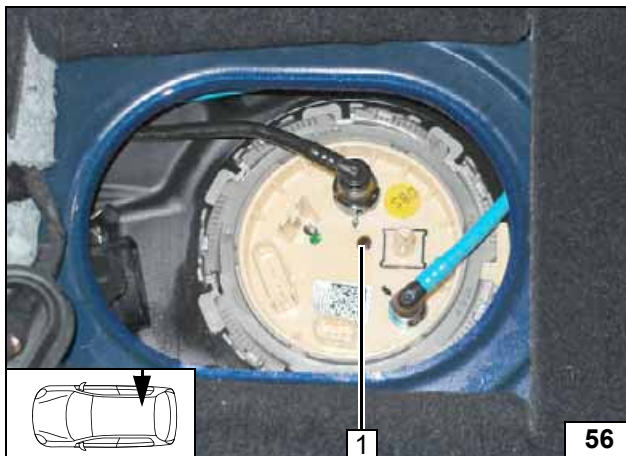

Work step F3.

- 1 Hole made with provided drill

Hole for FuelFix

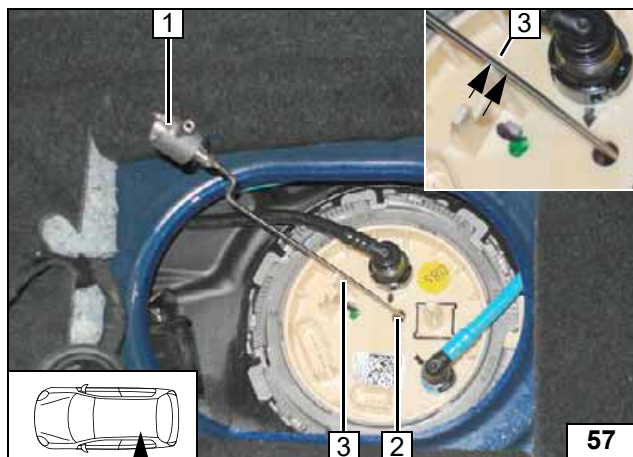

Work steps F4 and F5.

Bend FuelFix 1 according to template and cut to length. Insert into hole 2. When inserting place the FuelFix in position 3.



Inserting FuelFix



Inserting FuelFix



Inserting FuelFix

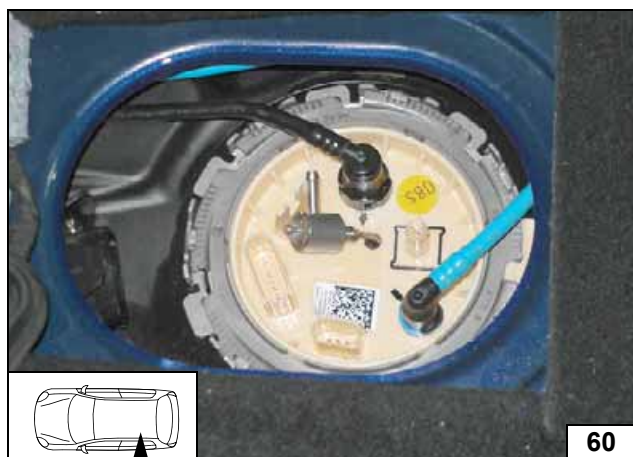

Inserting FuelFix

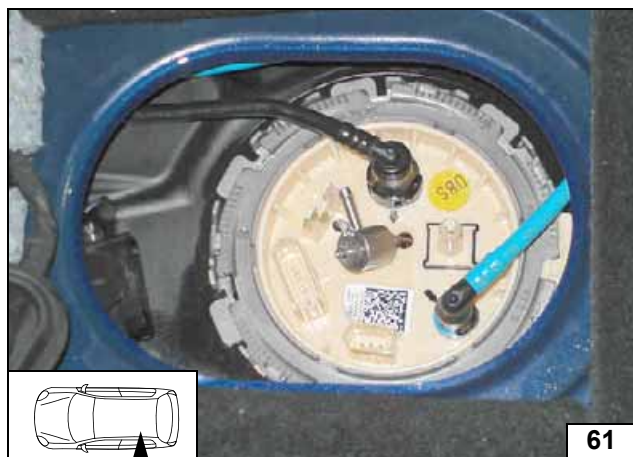

Inserting FuelFix

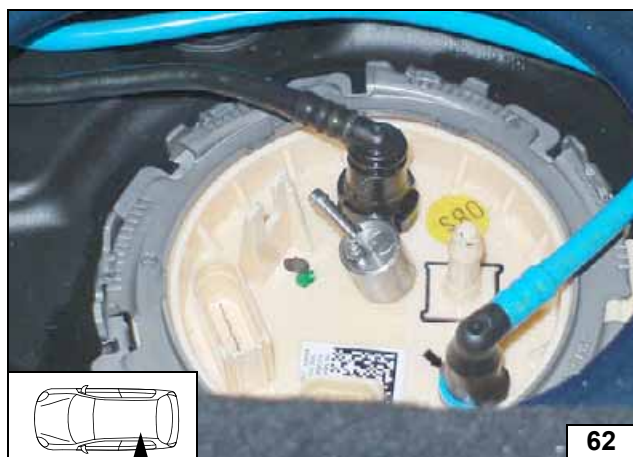

Inserting FuelFix

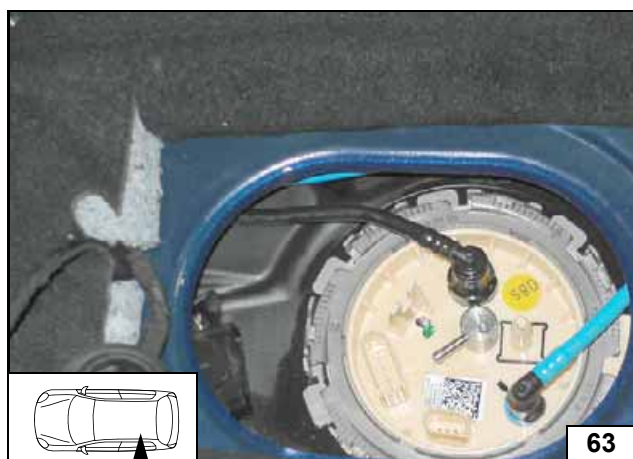

Work steps F5.3 and F5.4.

Align FuelFix as shown.



Aligning FuelFix

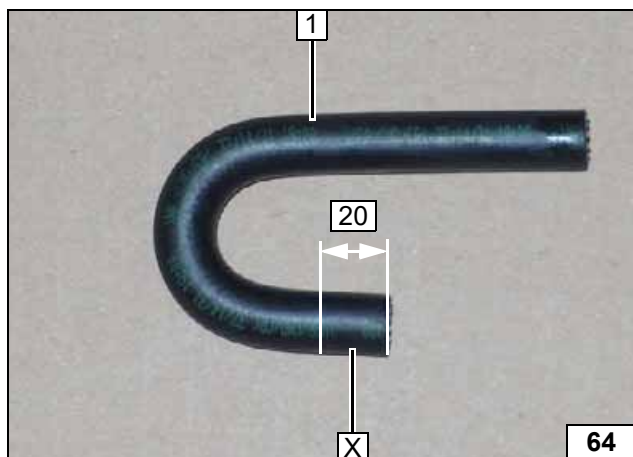

1 180° moulded hose

X =

Shortening moulded hose

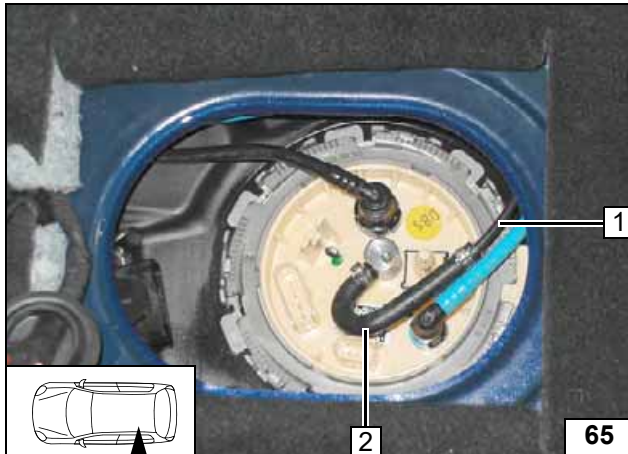

Work step F6.

- 1 Fuel line
- 2 180° moulded hose, 10 mm dia. clamp [2x]

Connect-
ing fuel line

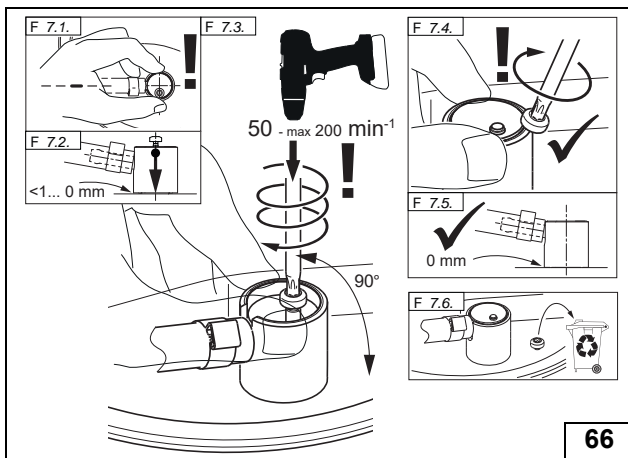

Work step F7.



Installing
FuelFix



Work step F8.

Ensuring
firm seating
of FuelFix

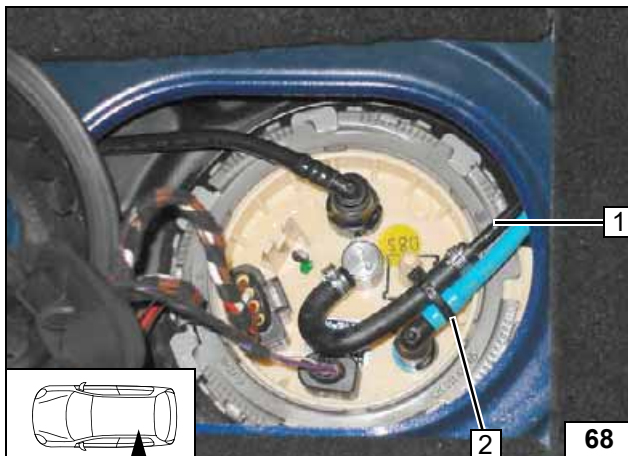

- 1 Fuel line of FuelFix
- 2 Cable tie as tension relief

Securing
fuel line

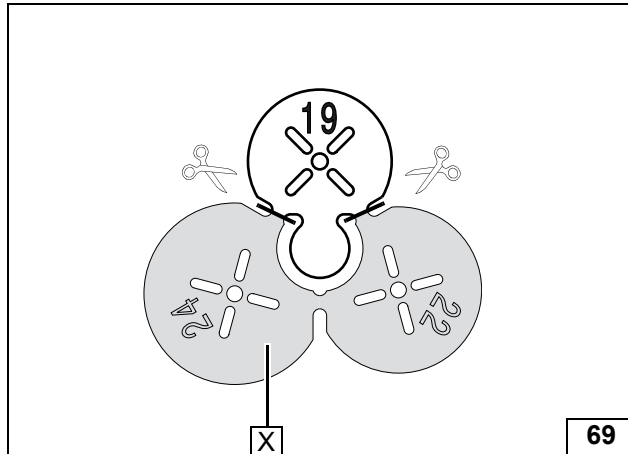
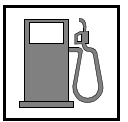

4Motion Diesel

X =

Preparing drilling template

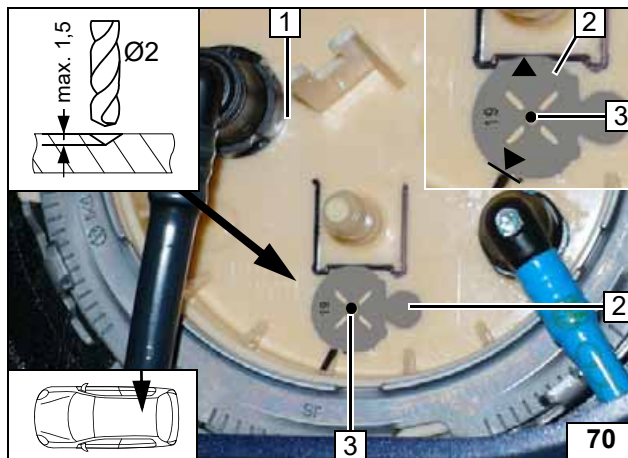

Work steps F1 and F2.

- 1 Fuel tank sending unit
- 2 Position 19mm dia. drilling template as shown
- 3 2mm dia. centring hole



Copying hole pattern

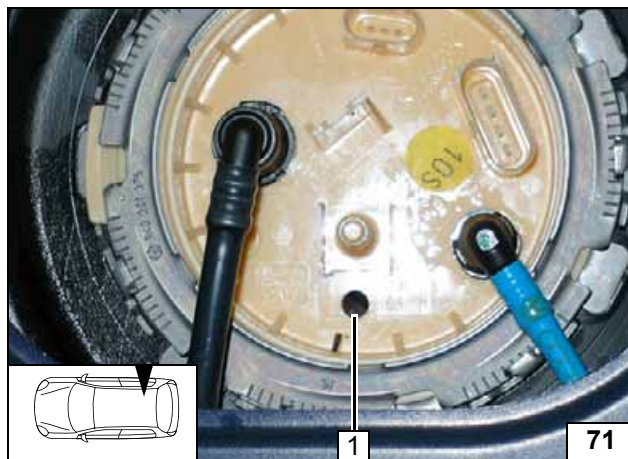

Work step F3.

- 1 Hole made with provided drill

Hole for FuelFix

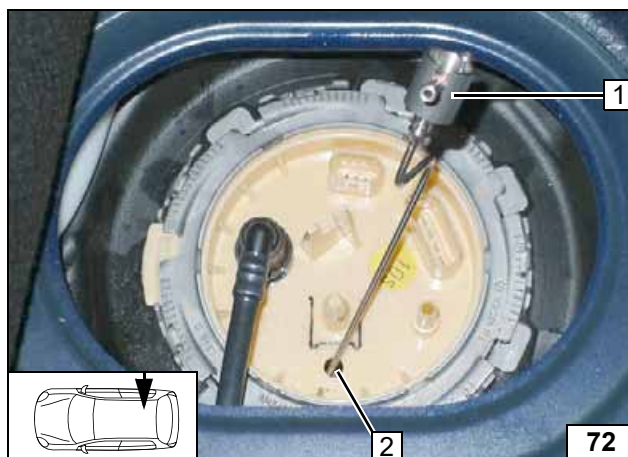

Work steps F4 and F5.

Bend FuelFix 1 according to template and cut to length. Insert into hole 2.



Inserting FuelFix



Work step F5.



Inserting
FuelFix



Inserting
FuelFix

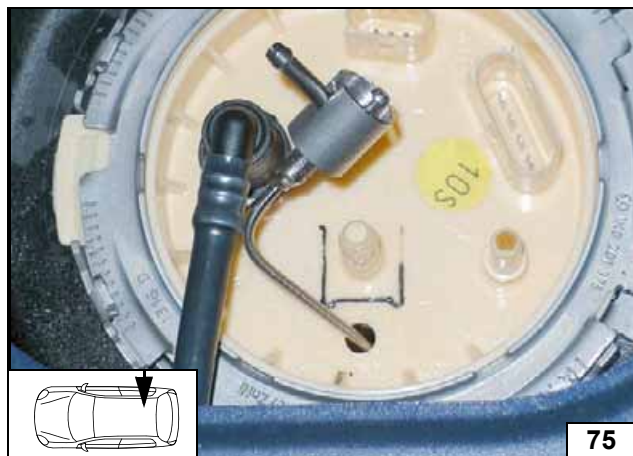

Inserting
FuelFix

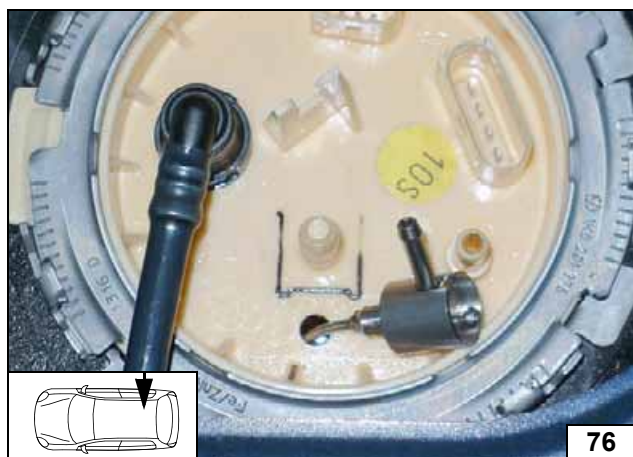

Inserting
FuelFix

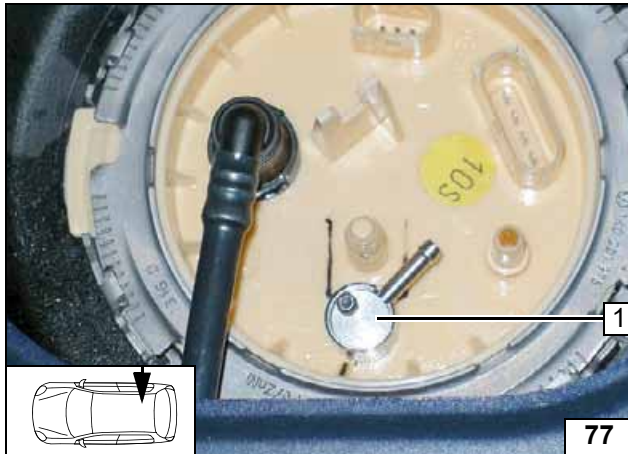

Work steps F5.3 and F5.4.

Align FuelFix 1 as shown.



Aligning FuelFix

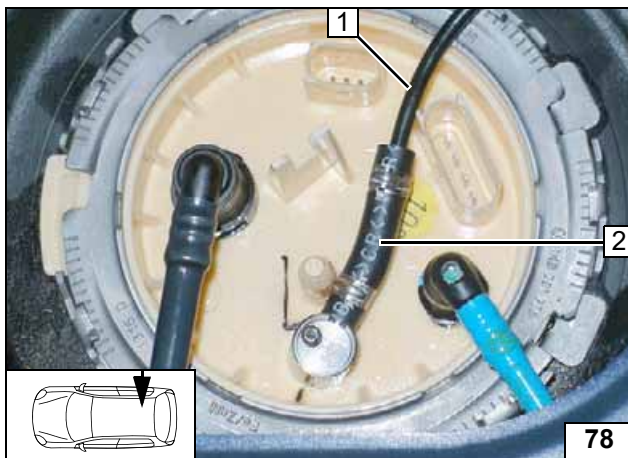

Work step F6.

- 1 Fuel line
- 2 Hose section, 10mm dia. clamp [2x]

Connecting fuel line

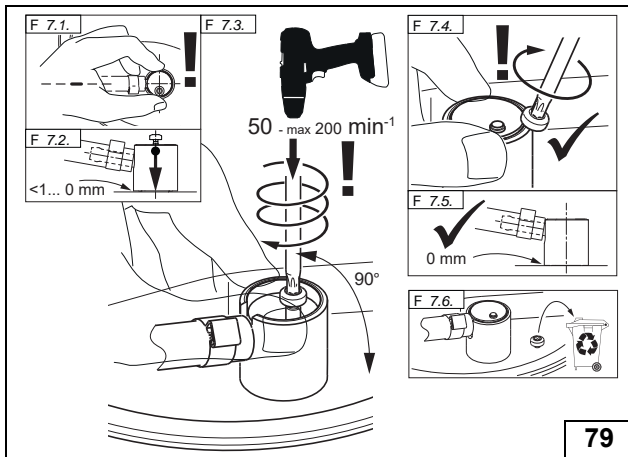

Work step F7.



Installing FuelFix

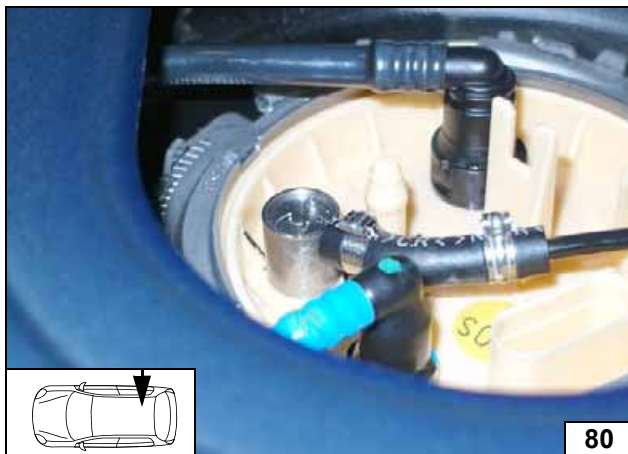

Work step F8.

Ensuring firm seating of FuelFix

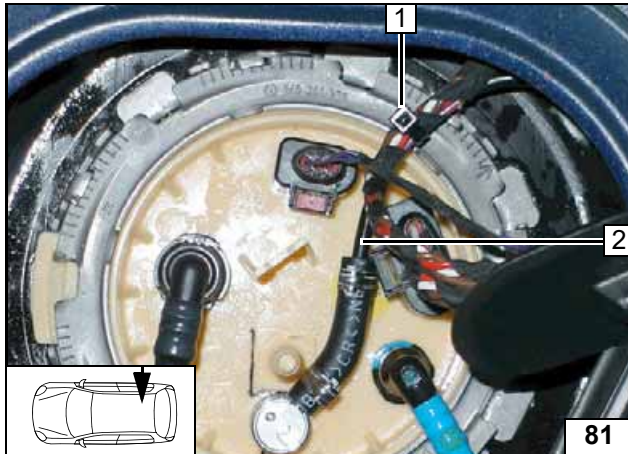

- 1 Cable tie as tension relief
- 2 Fuel line of FuelFix

Securing fuel line

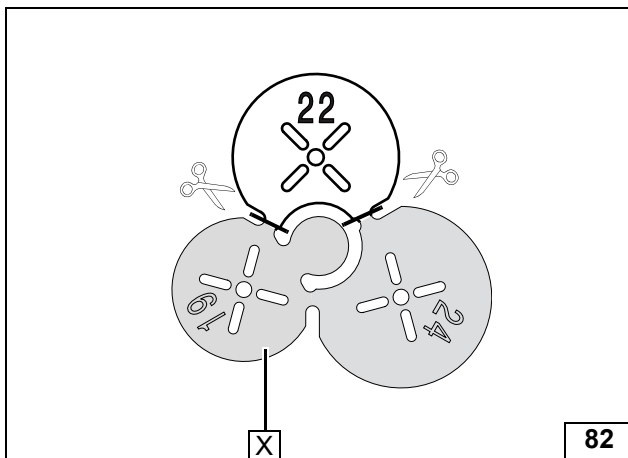

2WD petrol

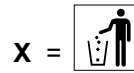

Preparing drilling template

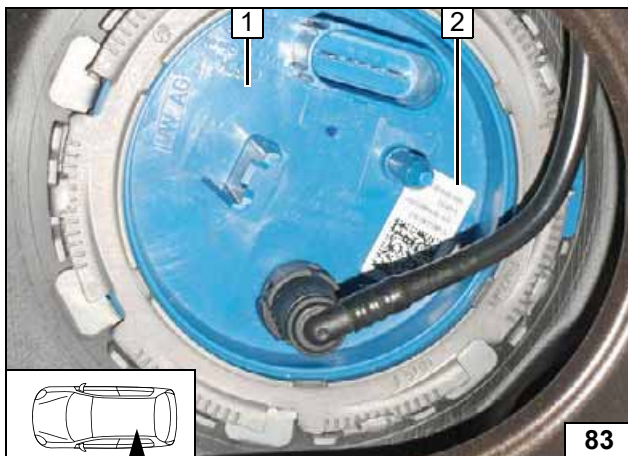

Work step F1.

Detach sticker 2.

- 1 Fuel tank sending unit



Moving sticker

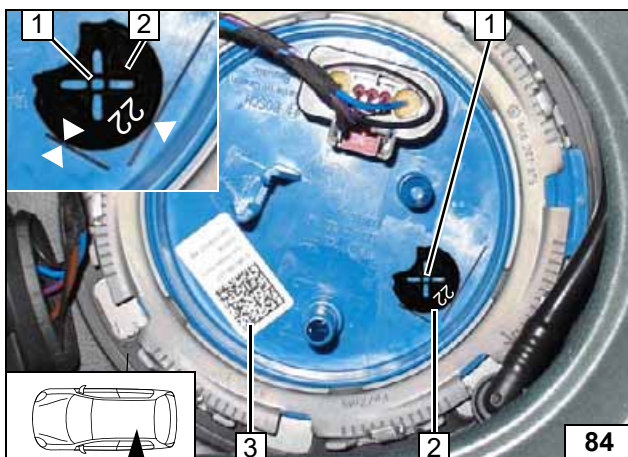

Work step F2.

- 1 Hole pattern
- 2 Position 22mm dia. template at the marking
- 3 Position sticker

Copying hole pattern

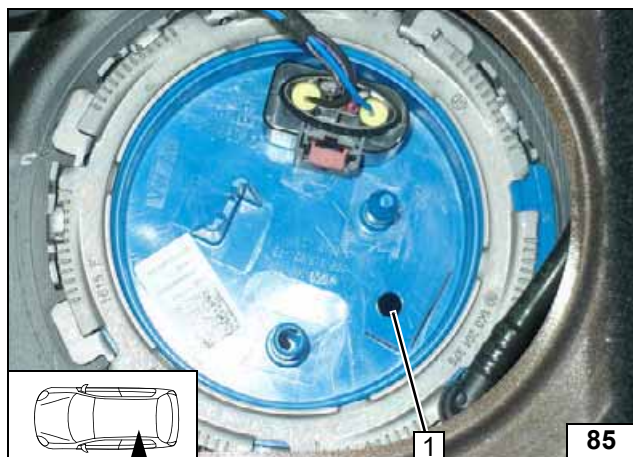

Work step F3.

- 1 Hole made with provided drill

Hole for FuelFix

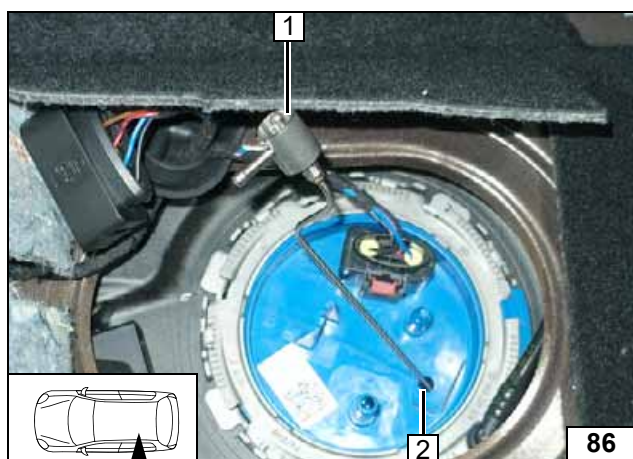

Work steps F4 and F5.

Bend FuelFix 1 according to template and cut to length. Insert into hole 2.



Inserting FuelFix

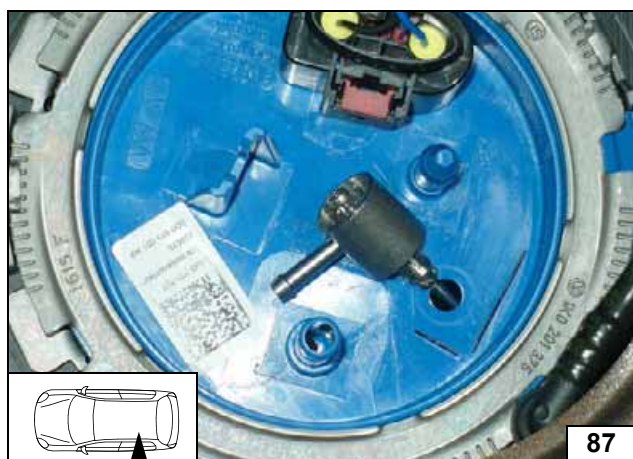

Inserting FuelFix

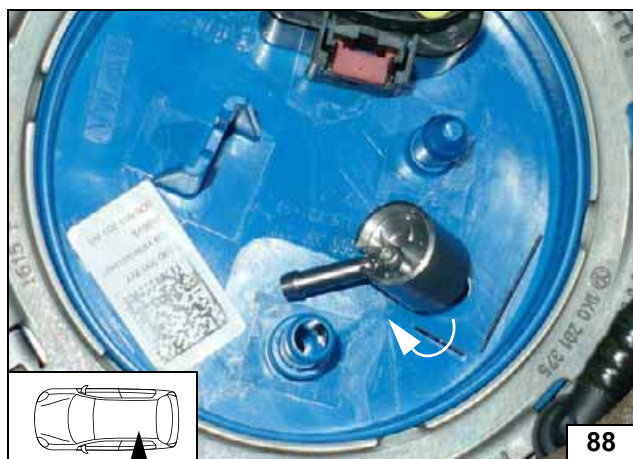

Inserting FuelFix

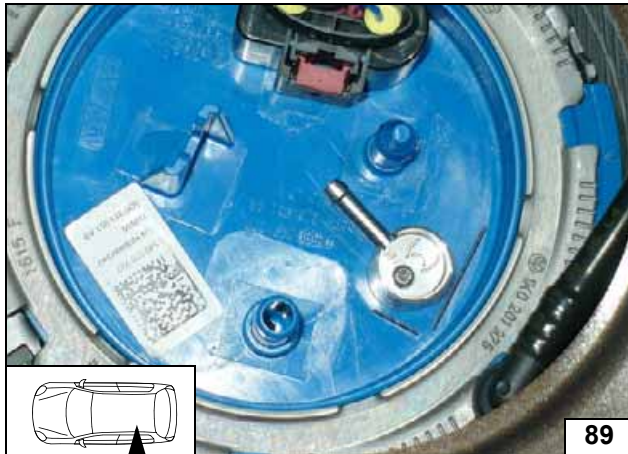
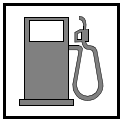

89

Work steps F5.3 and F5.4.

Align FuelFix 1 as shown.



Inserting FuelFix

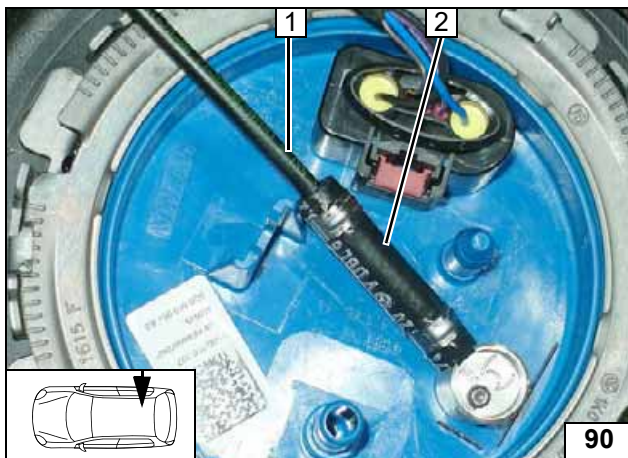

90

Work step F6.

Attach fuel line 1 at an appropriate point using a cable tie for tension relief.

2 Hose section, 10mm dia. clamp [2x]



Connecting fuel line

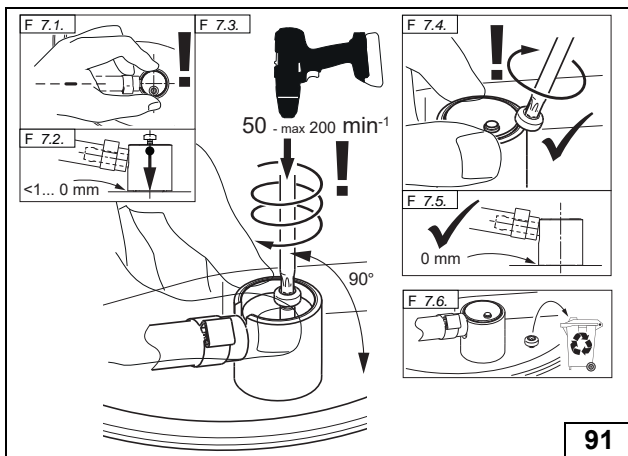

91

Work step F7.



Installing FuelFix

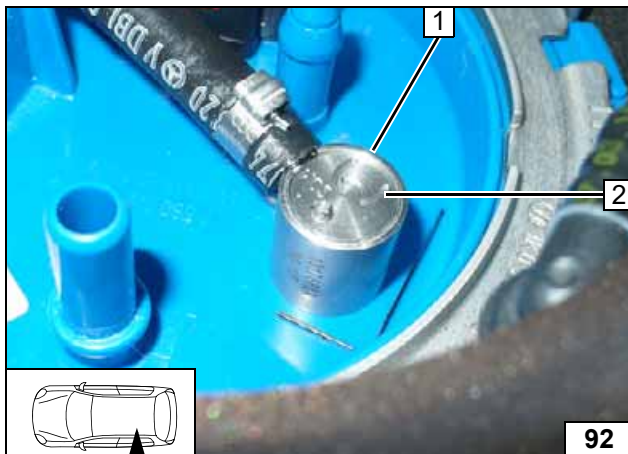

92

Work step F8.

Ensuring firm seating of FuelFix

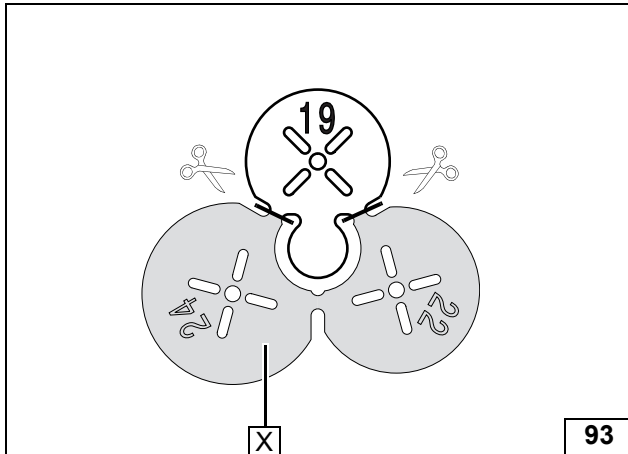

4Motion petrol

X =

Preparing drilling template

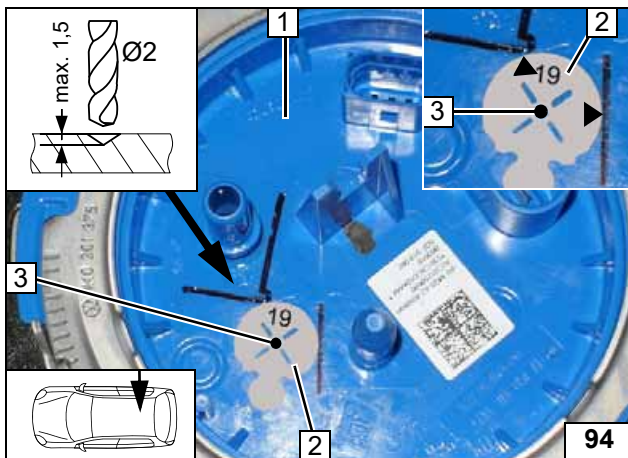

Work steps F1 and F2.

- 1 Fuel tank sending unit
- 2 Position 19mm dia. drilling template as shown
- 3 2mm dia. centring hole



Copying hole pattern



Work step F3.

- 1 Hole made with provided drill

Hole for FuelFix

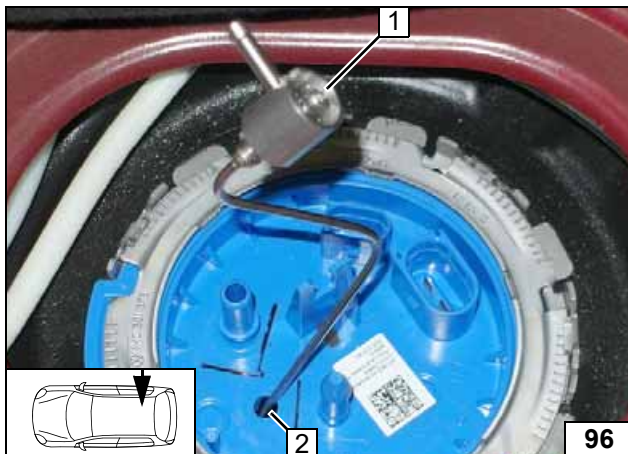

Work steps F4 and F5.

Bend FuelFix 1 according to template and cut to length. Insert into hole 2.



Inserting FuelFix



Work step F5.



Inserting
FuelFix



Inserting
FuelFix



Inserting
FuelFix



Inserting
FuelFix

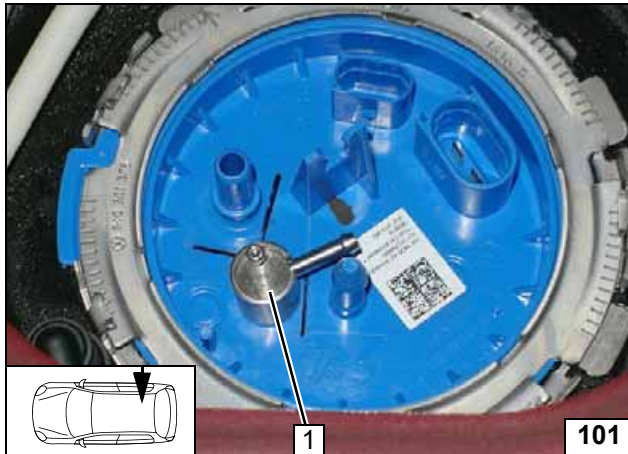

Work steps F5.3 and F5.4.

Align FuelFix 1 as shown.



Inserting FuelFix

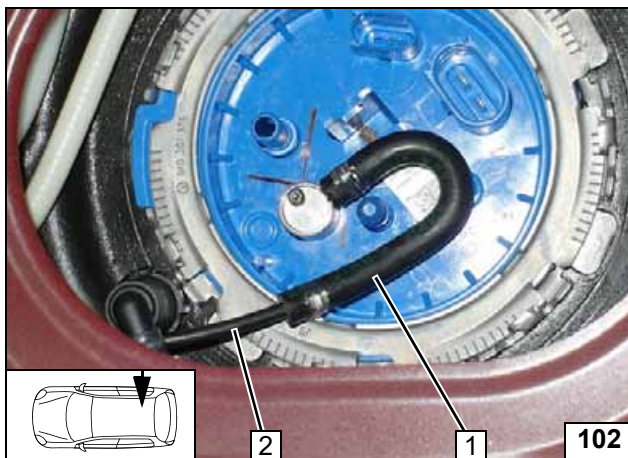

Work step F6.

- 1 Moulded hose, 10 mm dia. clamp [2x]
- 2 Fuel line

Connecting fuel line

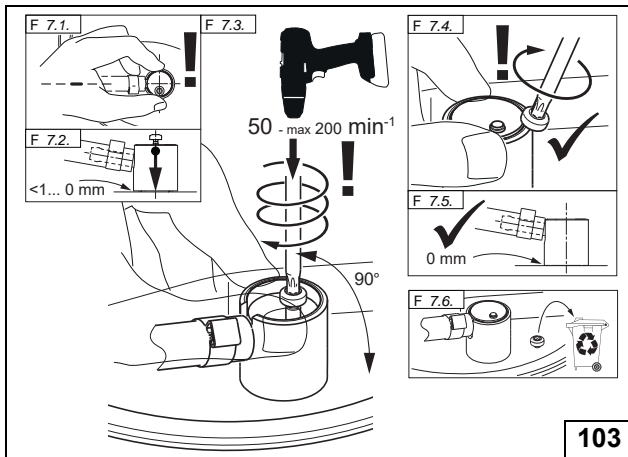

Work step F7.



Installing FuelFix

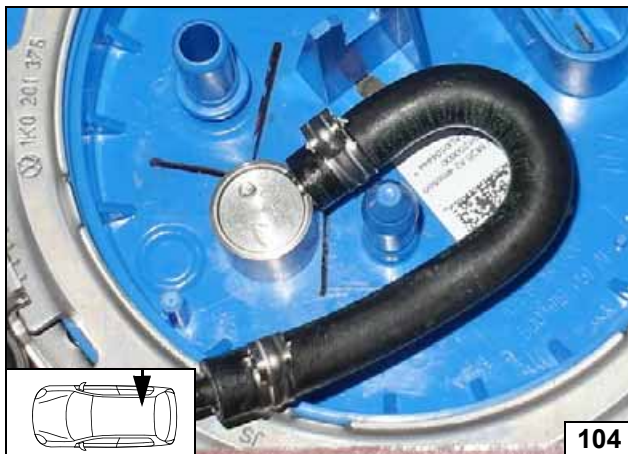

Work step F8.

Ensuring firm seating of FuelFix

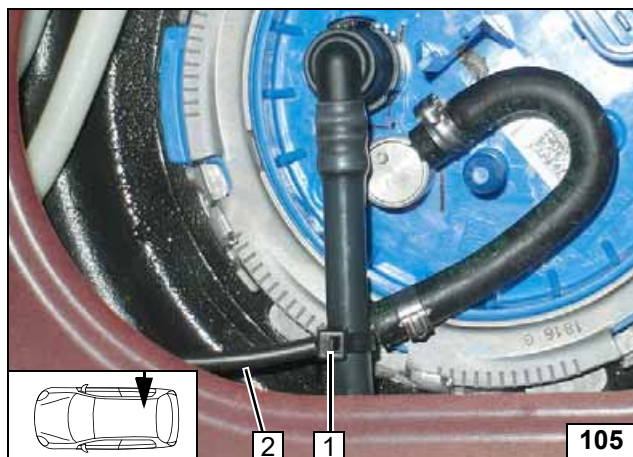

- 1 Cable tie as tension relief
- 2 Fuel line of FuelFix

Securing fuel line

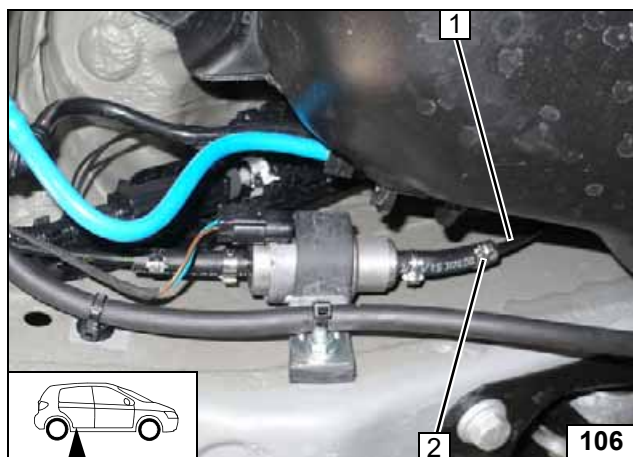

All vehicles

- 1 Fuel line of FuelFix
- 2 10 mm dia. clamp [2x]



**Connect-
ing meter-
ing pump**

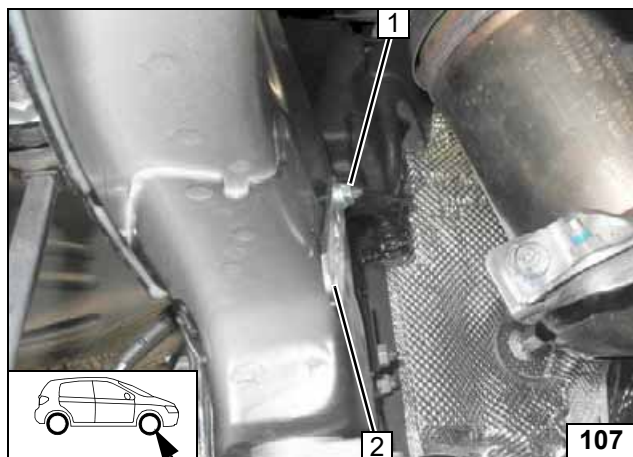

Preparing Hose Routing

- 1 M6 flanged nut, original vehicle stud bolt
- 2 Perforated bracket

Installing perforated bracket

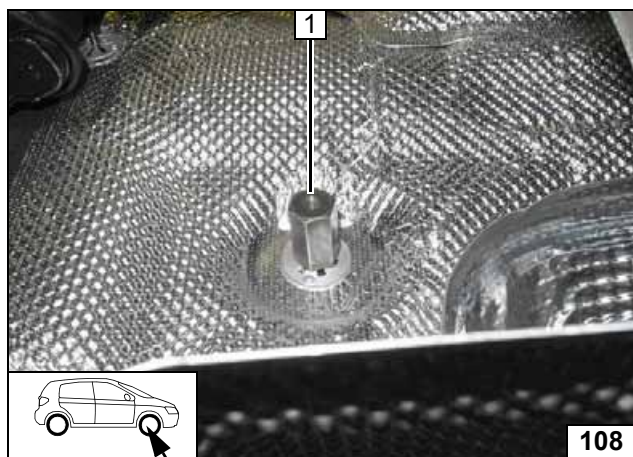

- 1 M6x30 spacer nut, original vehicle stud bolt

Installing spacer nut

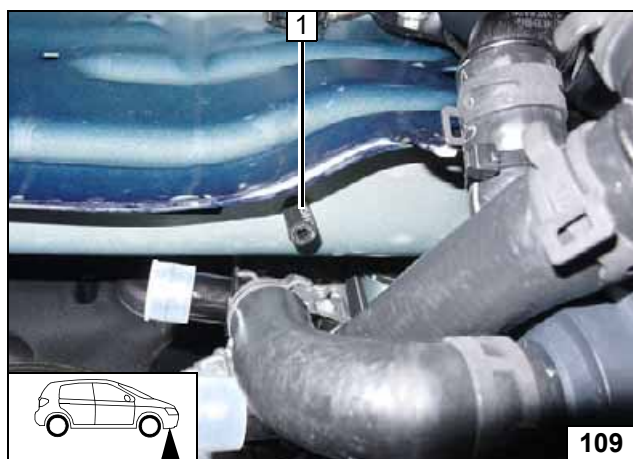

Install 20mm long hose section 1 onto original vehicle stud bolt.



Mounting hose section

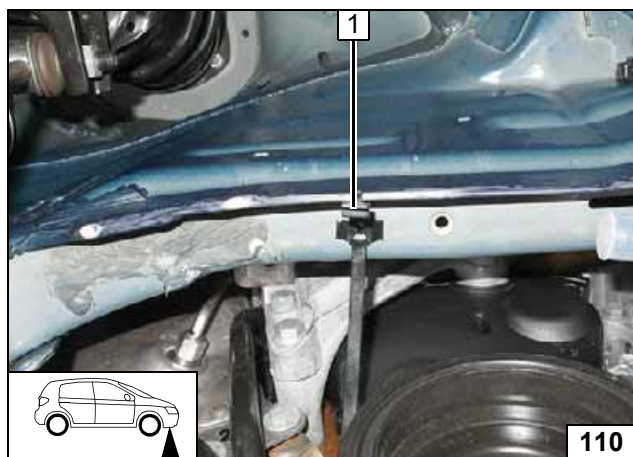

- 1 Eyelet cable tie in original vehicle hole

Installing cable tie

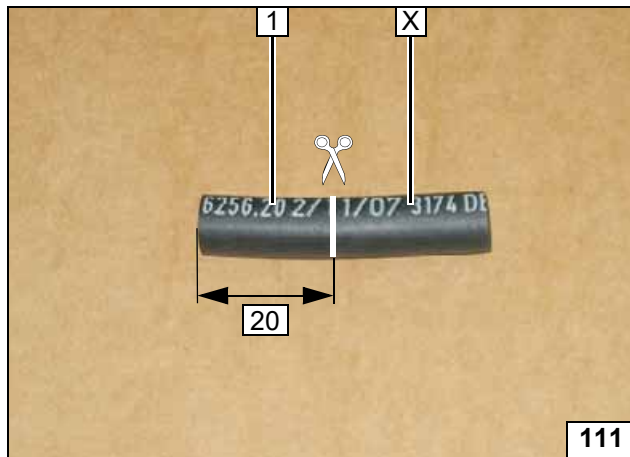

1 Hose section

X =

Cutting
hose section to
length



Coolant Circuit for 2WD Diesel Vehicles



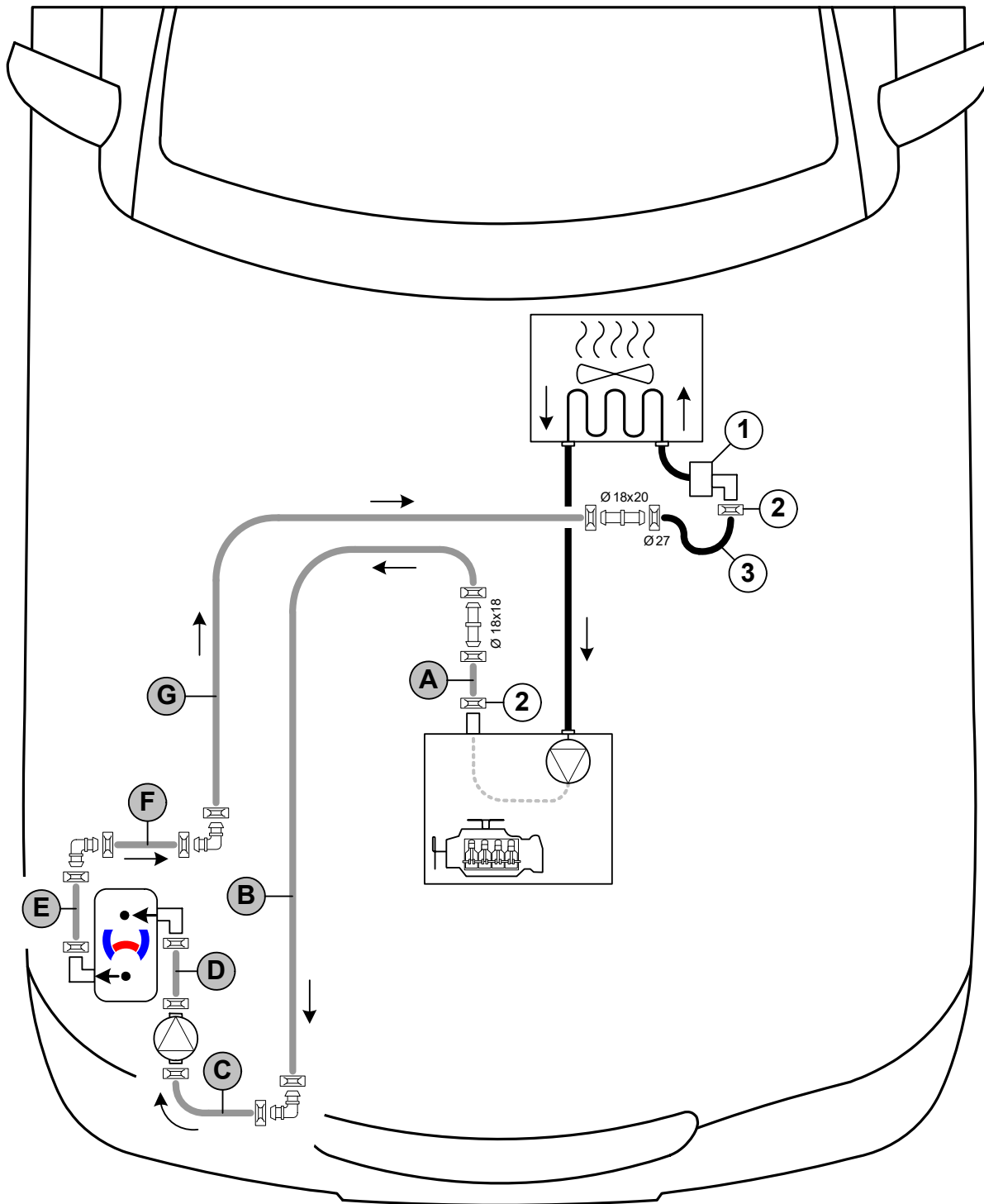

Any coolant running off should be collected in an appropriate container. Route hoses kink-free. Unless specified otherwise, always fasten using cable ties. Position clamps so that other hoses cannot be damaged. The heater must be filled with coolant when installing the hoses.

The connection should be modelled on an 'inline' circuit and based on the following diagram:



Hose routing diagram

All spring clips without a specific designation  = 25 mm dia. All connecting pipes  = 18x18 mm dia.

1 = EGR!

2 = Original vehicle spring clip .

3 = Original vehicle hose



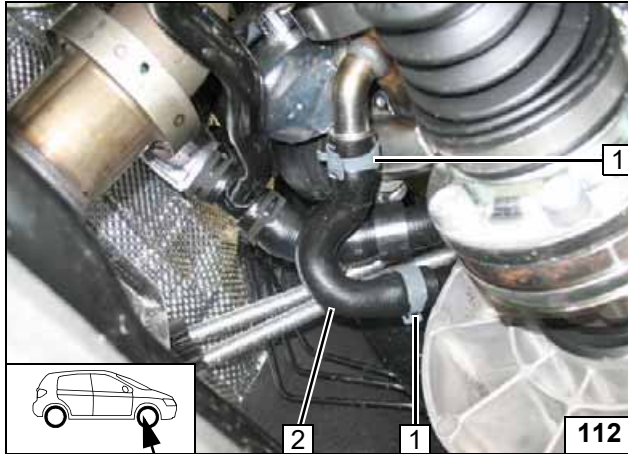

Remove hose from engine outlet / EGR inlet 2. Spring clips 1 [2x] will be reused.



Cutting point

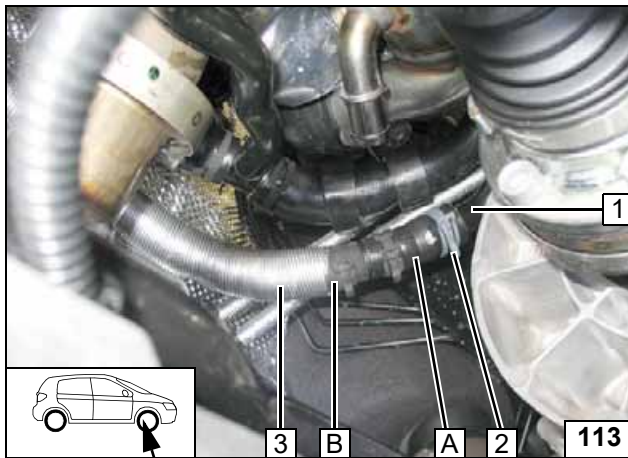

Slide 600mm long heat protection hose 3 onto hose B.



Connecting engine outlet

- 1 Pipe of engine outlet
- 2 Original vehicle spring clip

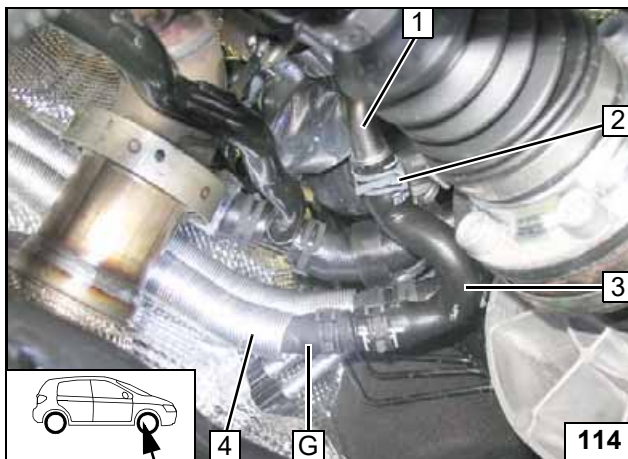

Slide 600mm long heat protection hose 4 onto hose B.



Connecting heat exchanger inlet

- 1 Pipe of EGR
- 2 Original vehicle spring clip
- 3 Original vehicle hose

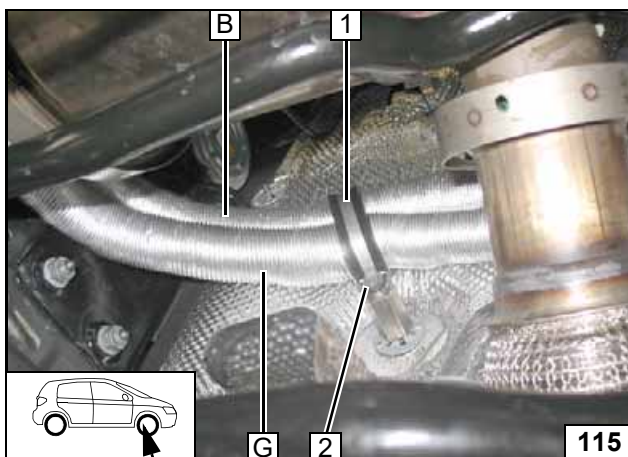

- 1 48 mm dia. rubber-coated p-clamp
- 2 M6x20 bolt, spring lockwasher

Fastening on firewall

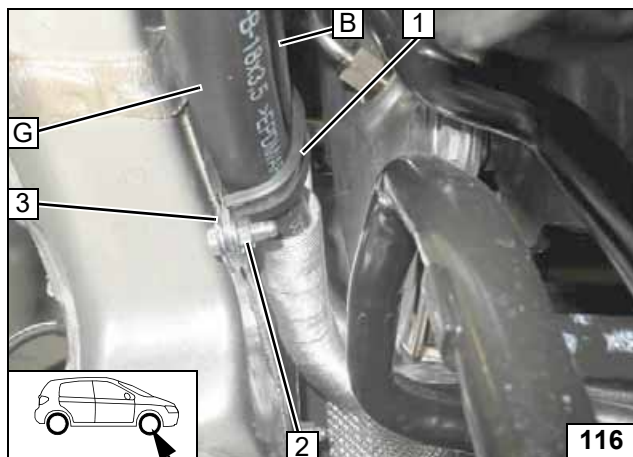

- 1 38 mm dia. rubber-coated p-clamp
- 2 M6x20 bolt, flanged nut
- 3 Perforated bracket

Routing on frame side member

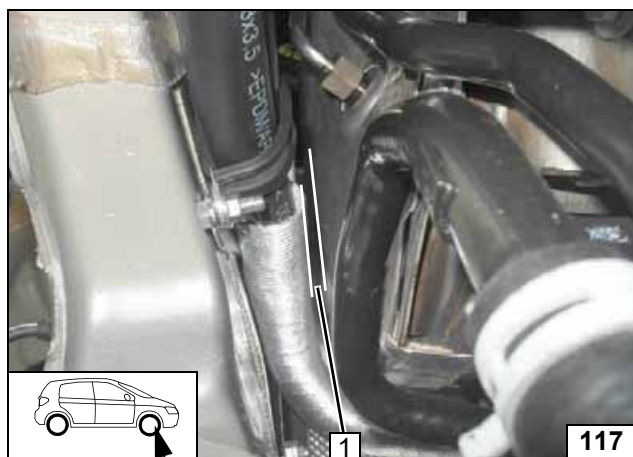

Align hoses. Ensure sufficient distance to catalytic converter at position 1, correct if necessary.



Routing in engine compartment

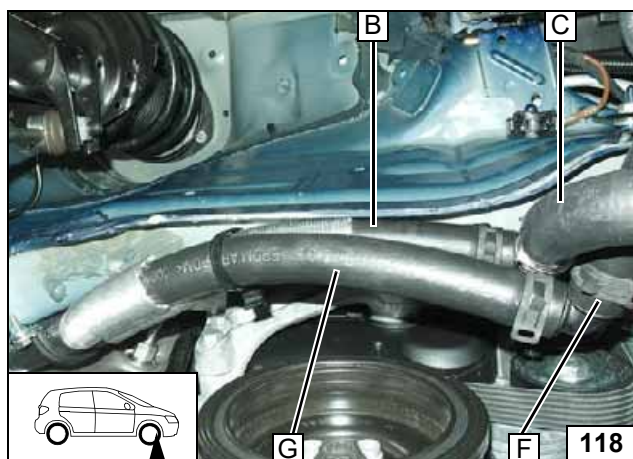

Align hoses. Ensure sufficient distance from neighbouring components, correct if necessary.



**Connect-
ing heater**



Coolant Circuit for 4Motion Diesel Vehicles



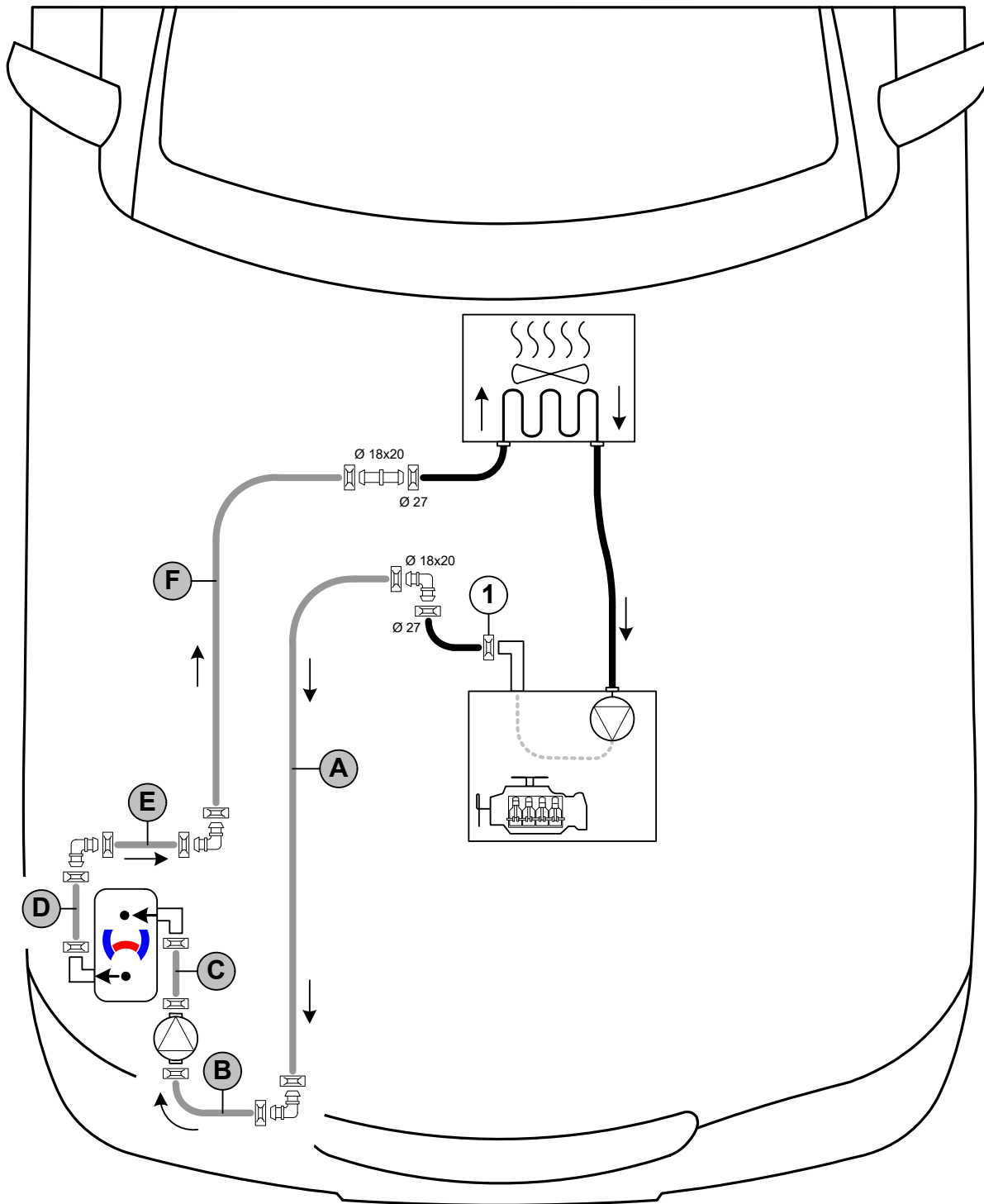

Any coolant running off should be collected in an appropriate container. Route hoses kink-free. Unless specified otherwise, always fasten using cable ties. Position clamps so that other hoses cannot be damaged. The heater must be filled with coolant when installing the hoses.

The connection should be modeled on an 'inline' circuit and based on the following diagram:



Hose routing diagram

All spring clips without a specific designation  = 25 mm dia.
 All connecting pipes without a specific designation  = 18x18 mm dia.
 1 = Original vehicle spring clip .



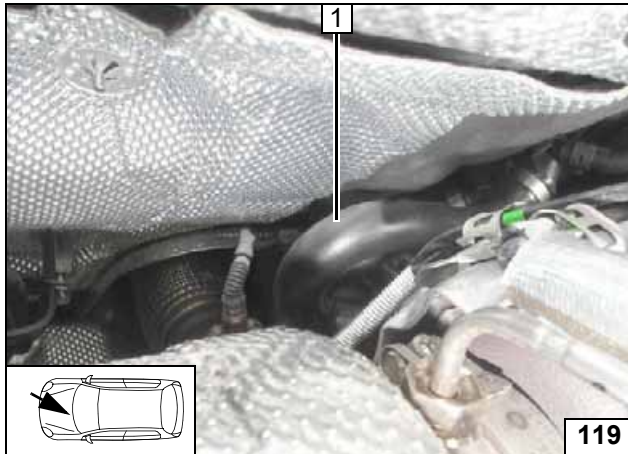

- 1 Hose of engine outlet / heat exchanger inlet

Dismantling engine outlet / heat exchanger inlet hose

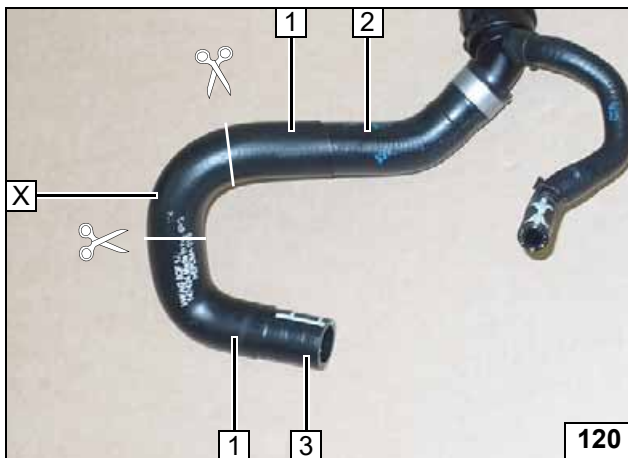

Cut off hose on engine outlet/heat exchanger inlet at marking. Remove protective hose 1 [2x] and discard.



- 2 Heat exchanger inlet hose section
- 3 Engine outlet hose section

Cutting point

X =

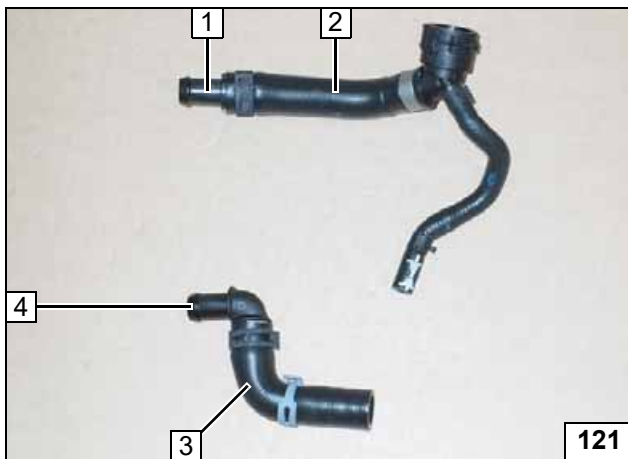

- 1 18x20mm dia. connecting pipe, 27mm dia. spring clip
- 2 Heat exchanger inlet hose section
- 3 Engine outlet hose section
- 4 90°, 18x20mm dia. connecting pipe, 27mm dia. spring clip

Preparing hose sections

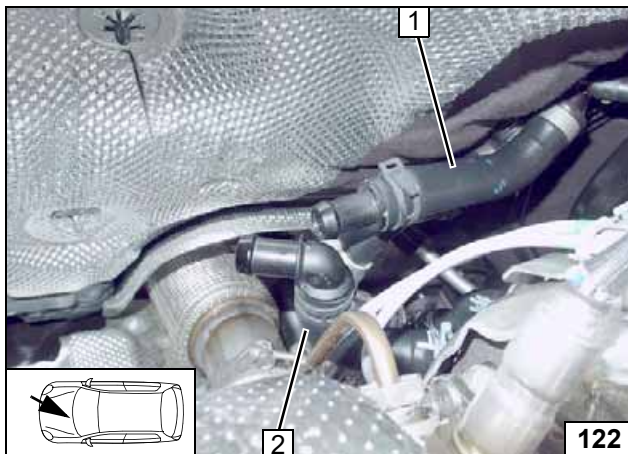

- 1 Heat exchanger inlet hose section
- 2 Engine outlet hose section

Installing hose sections

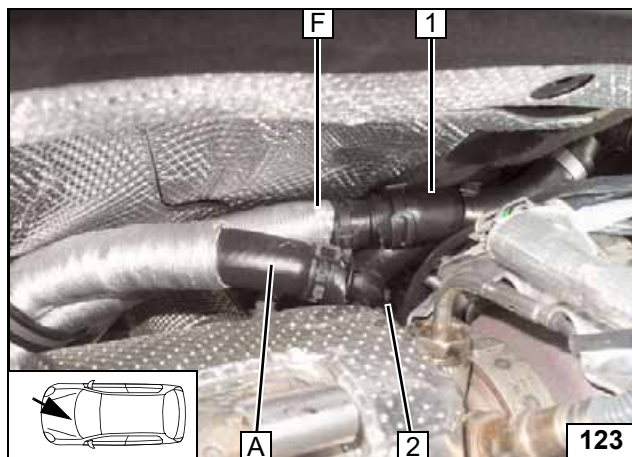
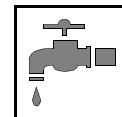

Slide one 600mm long heat protection hose each onto hoses **A** and **F**.

- 1 Heat exchanger inlet hose section
- 2 Engine outlet hose section



**Connect-
ing engine
outlet / heat
exchanger
inlet**

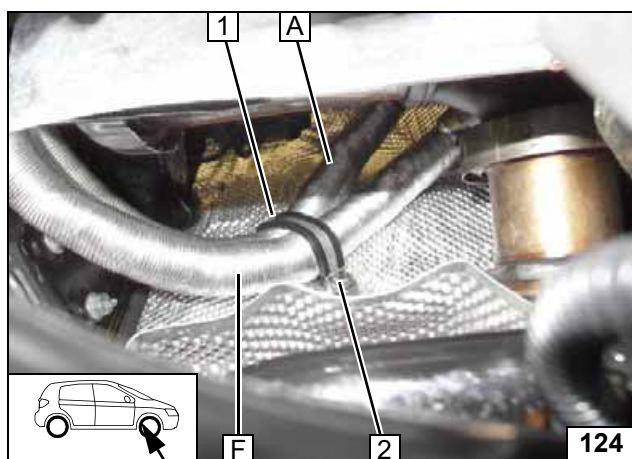

- 1 48 mm dia. rubber-coated p-clamp
- 2 M6x20 bolt, spring lockwasher

**Fastening on
firewall**

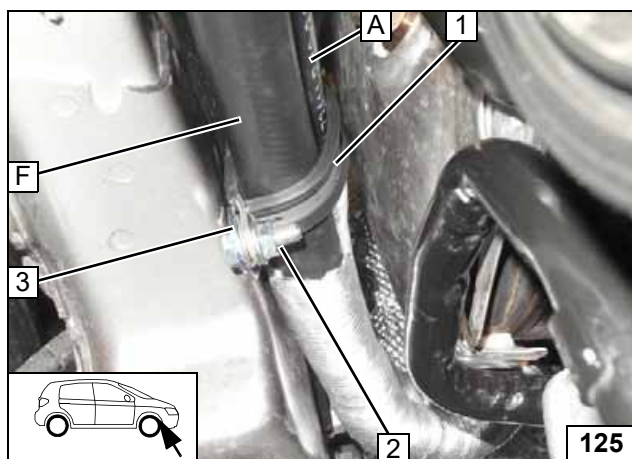

- 1 38 mm dia. rubber-coated p-clamp
- 2 M6x20 bolt, flanged nut
- 3 Perforated bracket

**Routing on
frame side
member**

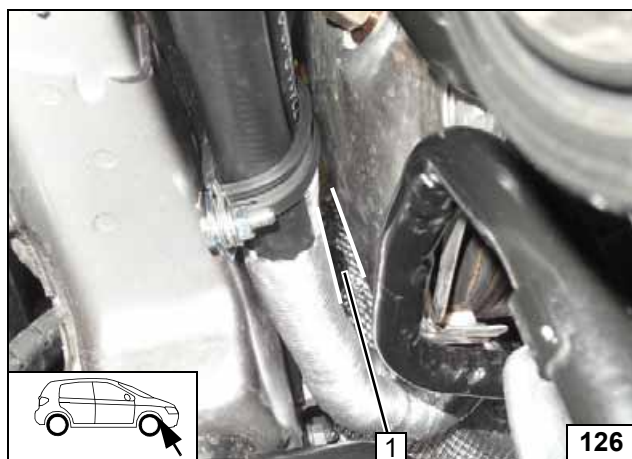

Align hoses. Ensure sufficient distance to catalytic converter at position **1**, correct if necessary.



**Routing in
engine
compartment**

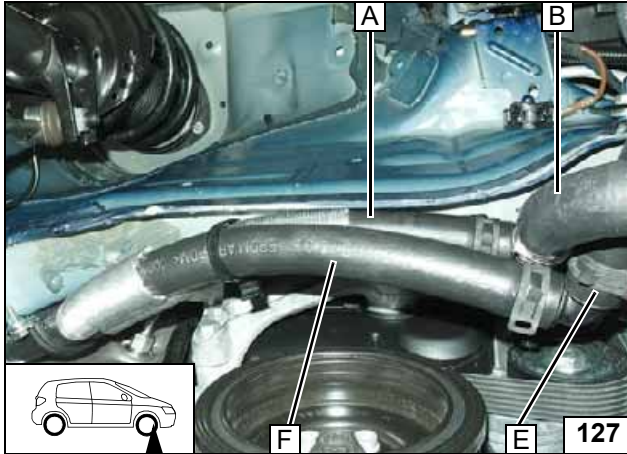
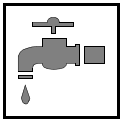

Align hoses. Ensure sufficient distance from neighbouring components, correct if necessary.



**Connect-
ing heater**



Coolant Circuit for 2WD Petrol Vehicles





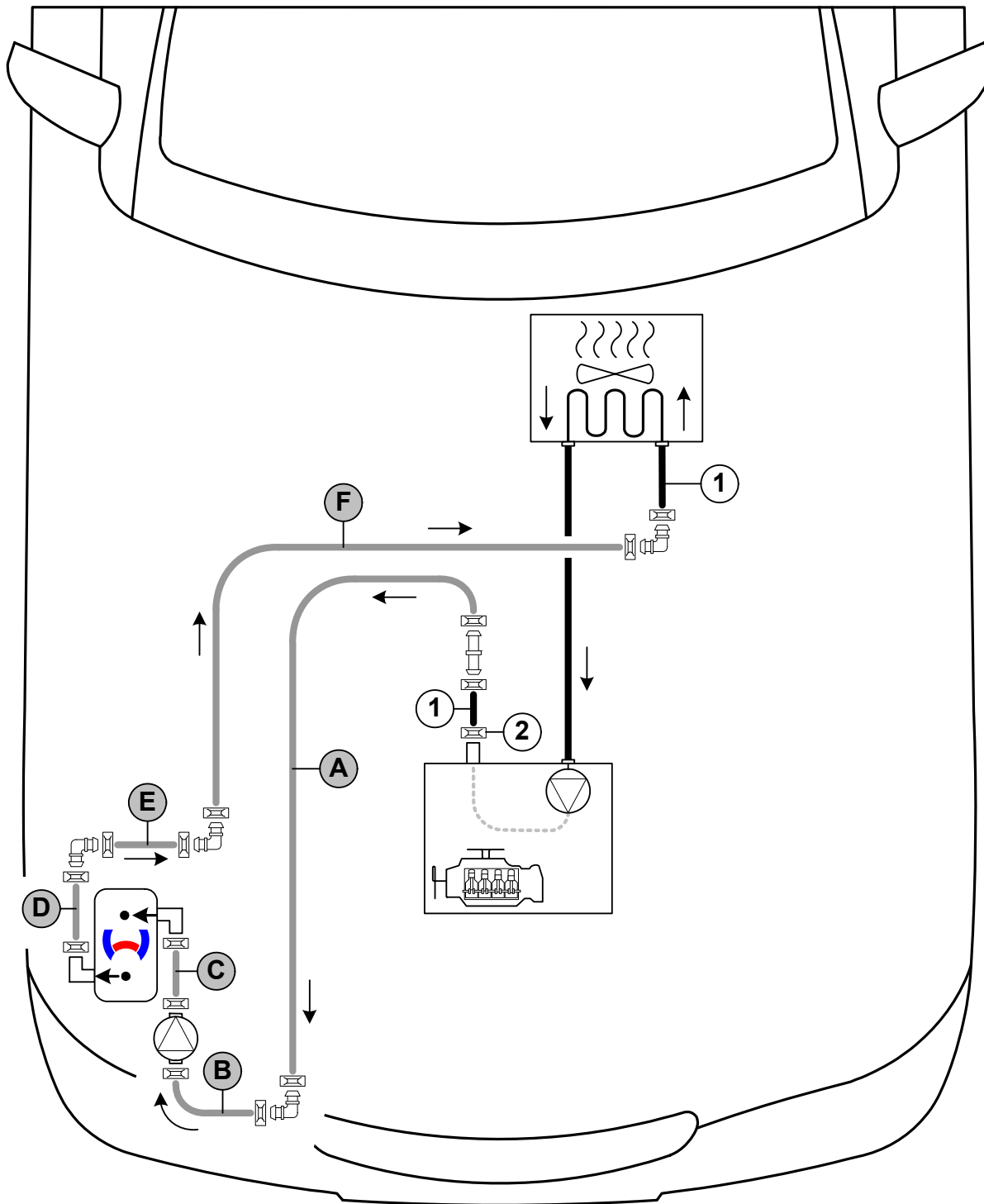

Any coolant running off should be collected in an appropriate container. Route hoses kink-free. Unless specified otherwise, always fasten using cable ties. Position clamps so that other hoses cannot be damaged. The heater must be filled with coolant when installing the hoses.

The connection should be modelled on an 'inline' circuit and based on the following diagram:



Hose routing diagram

All spring clips without a specific designation  = 25 mm dia. All connecting pipes  and  = 18x18 mm dia.
 1 = Original vehicle hose
 2 = Original vehicle spring clip .



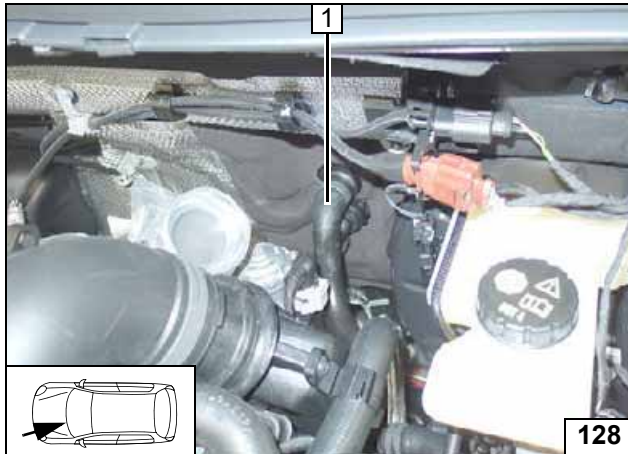

Remove engine outlet / heat exchanger inlet hose 1. Spring clip will be reused.



Cutting point

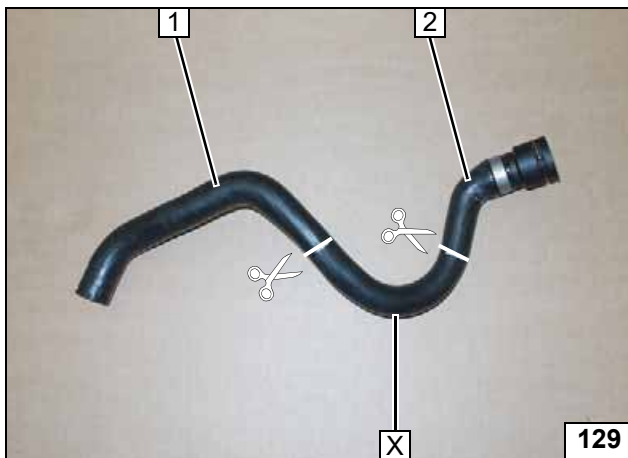

Remove protective hose at cutting point.



- 1 Engine outlet hose section
- 2 Heat exchanger inlet hose section

X =

Cutting point

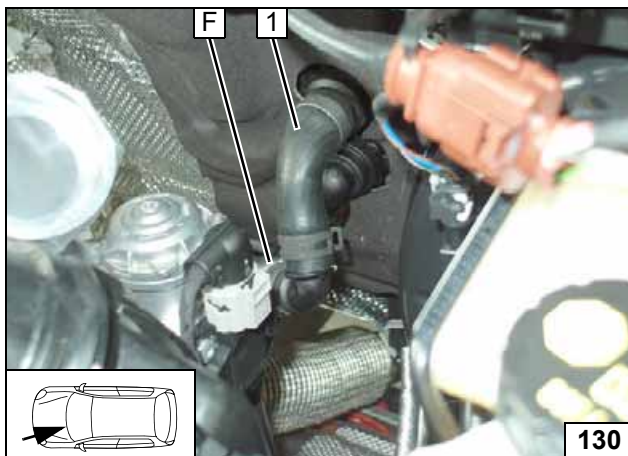

- 1 Heat exchanger inlet hose section

Connect-
ing heat ex-
changer
inlet

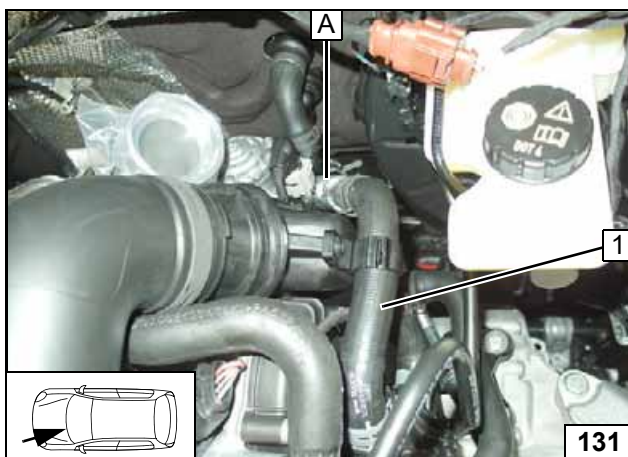

- 1 Engine outlet hose section

Connect-
ing engine
outlet

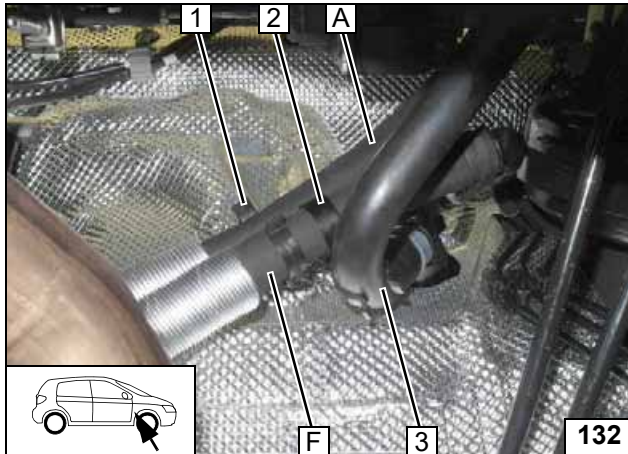

Slide one 600mm long heat protection hose each onto hoses **A** and **F**.

- 1 Spacer bracket
- 2 Twistable spacer bracket
- 3 Heat exchanger outlet hose section



Routing on firewall

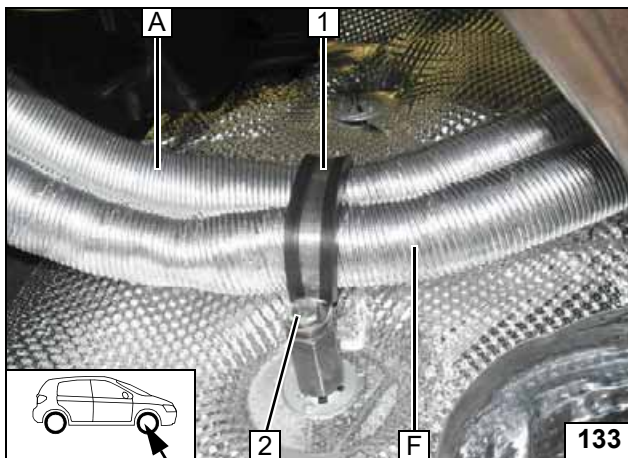

- 1 48 mm dia. rubber-coated p-clamp
- 2 M6x20 bolt, spring lockwasher

Fastening on firewall

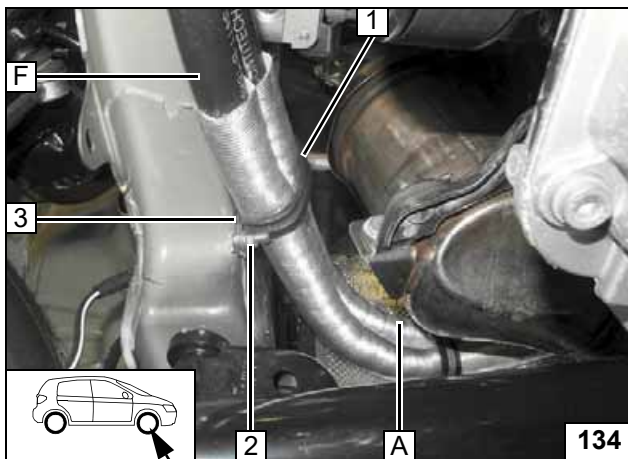

Align hoses. Ensure sufficient distance to catalytic converter, correct if necessary.

- 1 48 mm dia. rubber-coated p-clamp
- 2 M6x20 bolt, flanged nut
- 3 Perforated bracket



Routing on frame side member

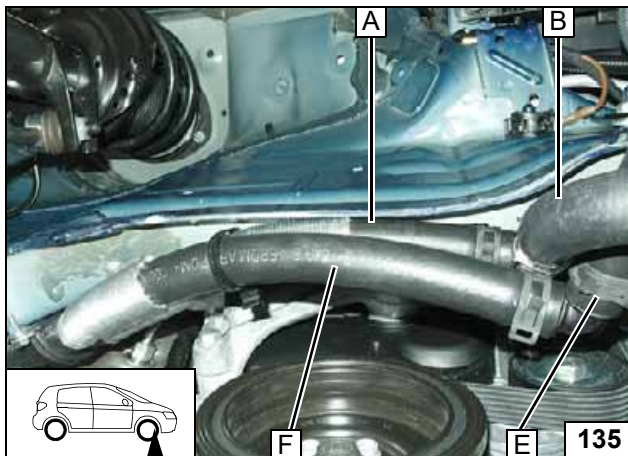

Align hoses. Ensure sufficient distance from neighbouring components, correct if necessary.



Connecting heater



Coolant Circuit for 4Motion Petrol Vehicles



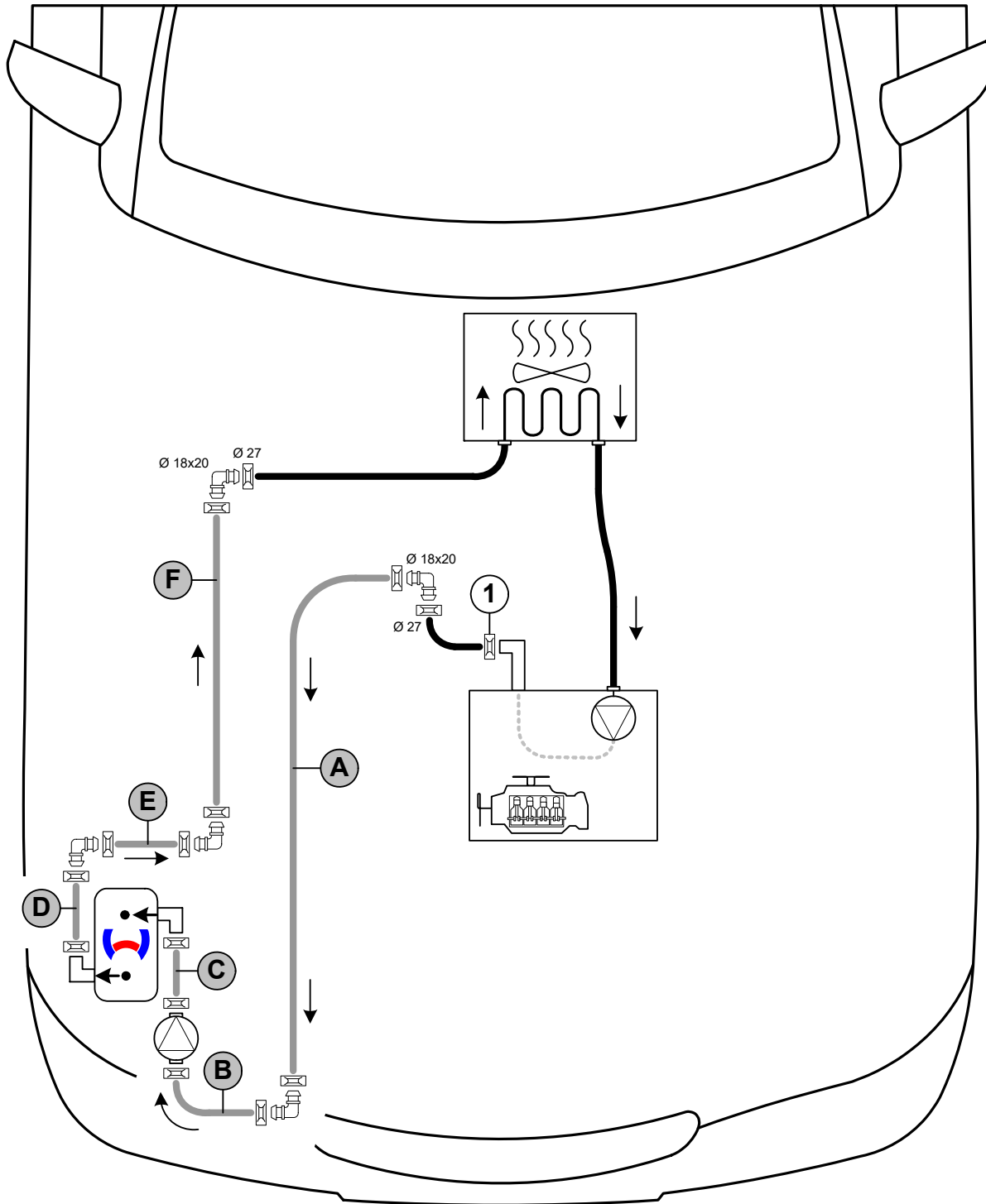

Any coolant running off should be collected in an appropriate container. Route hoses kink-free. Unless specified otherwise, always fasten using cable ties. Position clamps so that other hoses cannot be damaged. The heater must be filled with coolant when installing the hoses.

The connection should be modelled on an 'inline' circuit and based on the following diagram:



Hose routing diagram

All spring clips without a specific designation  = 25 mm dia.
 All connecting pipes without a specific designation  = 18x18 mm dia.
 1 = Original vehicle spring clip .



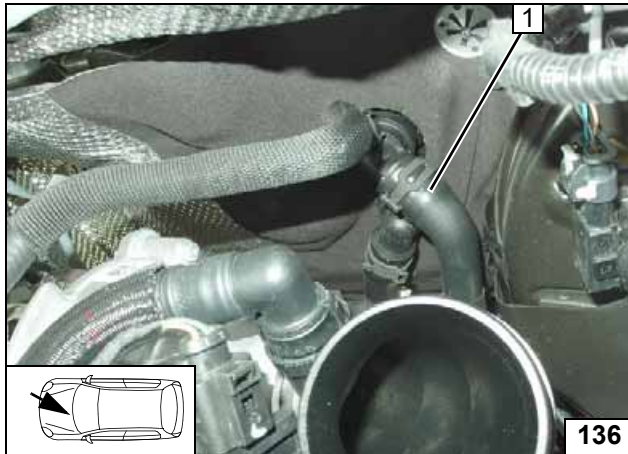

1 Hose of engine outlet / heat exchanger inlet

Dismantling engine outlet / heat exchanger inlet hose

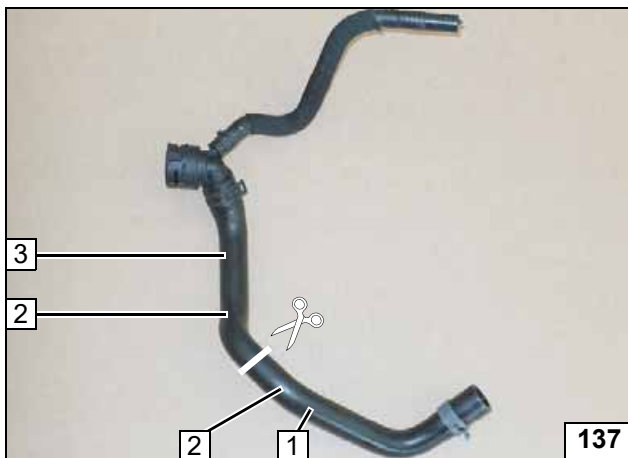

Cut off hose on engine outlet/heat exchanger inlet at marking. Remove protective hose 2 [2x] and discard.



- 1 Engine outlet hose section
- 3 Heat exchanger inlet hose section

Cutting point

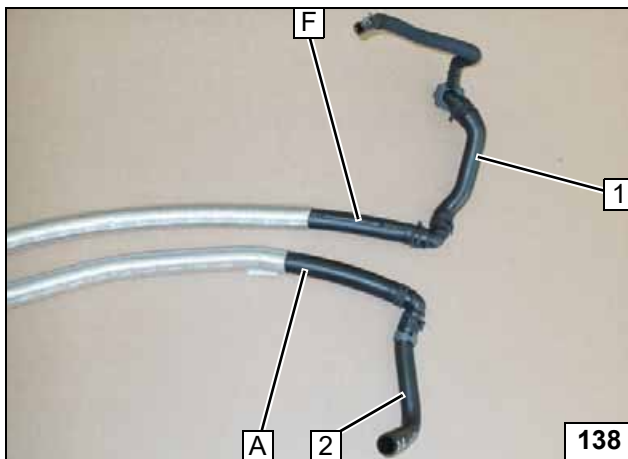

Slide one 600mm long heat protection hose each onto hoses A and F.



- 1 Heat exchanger inlet hose section
- 2 Engine outlet hose section

Preparing hose sections

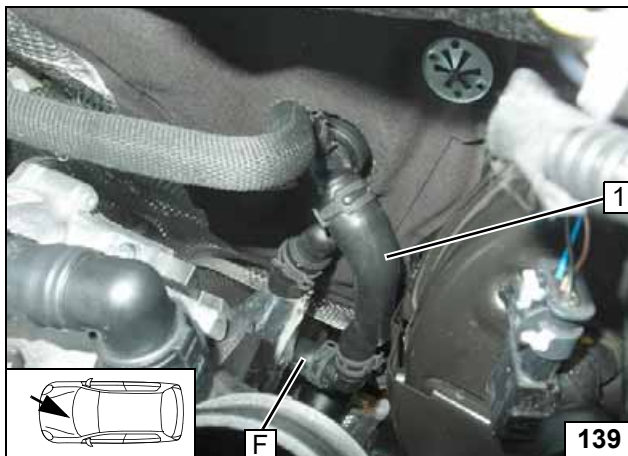

- 1 Heat exchanger inlet hose section

Connecting heat exchanger inlet

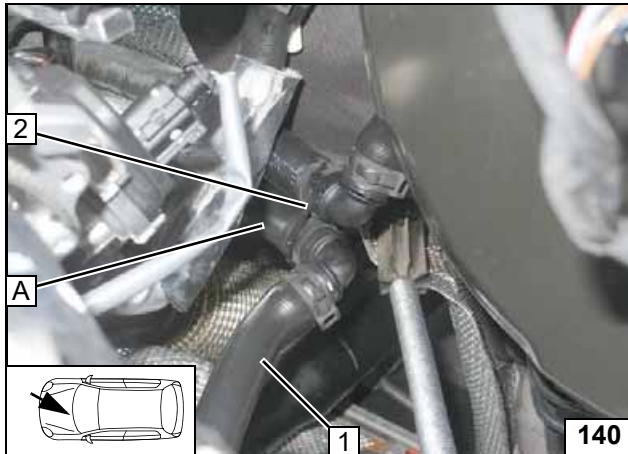

- 1 Engine outlet hose section
- 2 Cable tie

**Connect-
ing engine
outlet**

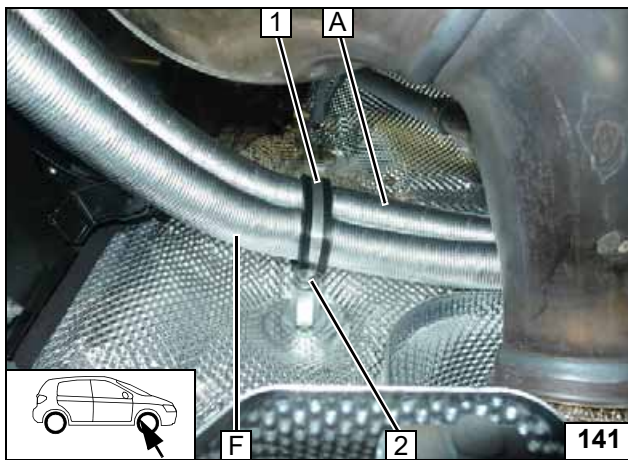

- 1 48 mm dia. rubber-coated p-clamp
- 2 M6x20 bolt, spring lockwasher

**Fastening on
firewall**

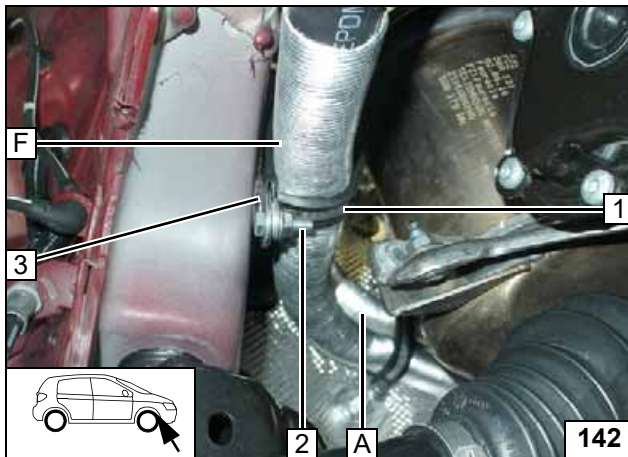

- 1 38 mm dia. rubber-coated p-clamp
- 2 M6x20 bolt, flanged nut
- 3 Perforated bracket

**Routing on
frame side
member**

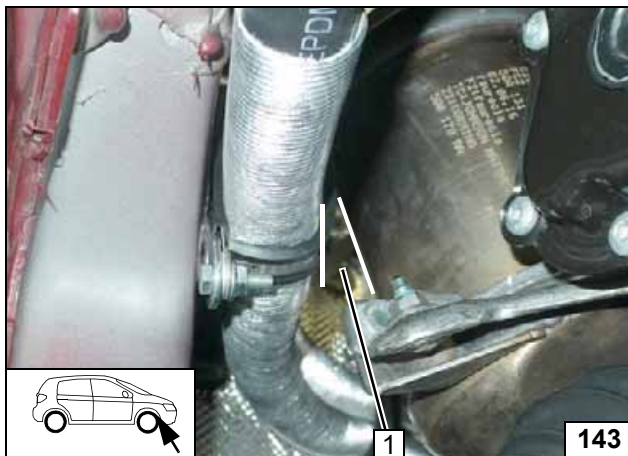

Align hoses. Ensure sufficient distance to catalytic converter at position 1, correct if necessary.



**Routing in
engine
compartment**

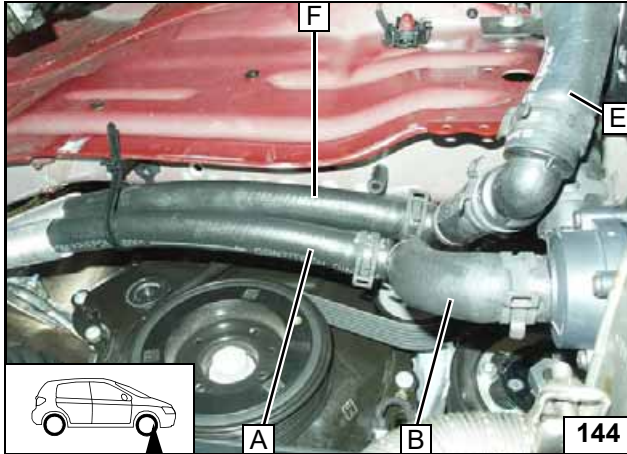
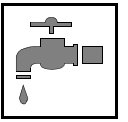

Align hoses. Ensure sufficient distance from neighbouring components, correct if necessary.



**Connect-
ing heater**



Final Work



Reassemble the components in reverse order. Check all hoses, clamps and all electrical connections for firm seating. Insulate and tie back loose lines. Only use manufacturer-approved coolant. Spray the heater components with anti-corrosion wax (Tectyl 100K).

- **Connect the battery.**
- **Fill and bleed the coolant circuit according to the vehicle manufacturer's instructions.**
- **Program MultiControl CAR, teach Telestart transmitter.**
- **For initial start-up and function check, please see installation instructions.**
- **If the fan function or A/C control panel settings need to be checked, see the installation documentation in the additional kit 'Webasto Standard' or 'Webasto Comfort' A/C control, section 'Final Work'.**
- **Place the 'Switch off parking heater before refuelling' caution label near the filler neck.**

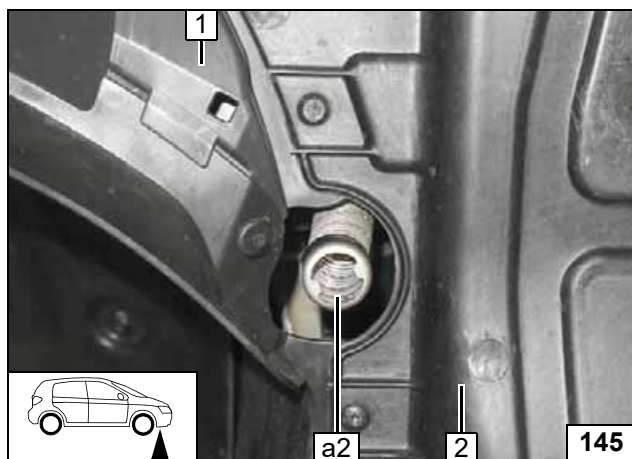

Align exhaust pipe **a2** with centre of pass through.

- 1 Wheel well trim installed
- 2 Underride protection installed



Aligning exhaust pipe a2

Webasto Thermo & Comfort SE
 Postfach 1410
 82199 Gilching
 Germany
 Internet: www.webasto.com
 Technical Extranet:
<http://dealers.webasto.com>



FuelFix Template for 2WD Diesel Vehicles

Top view

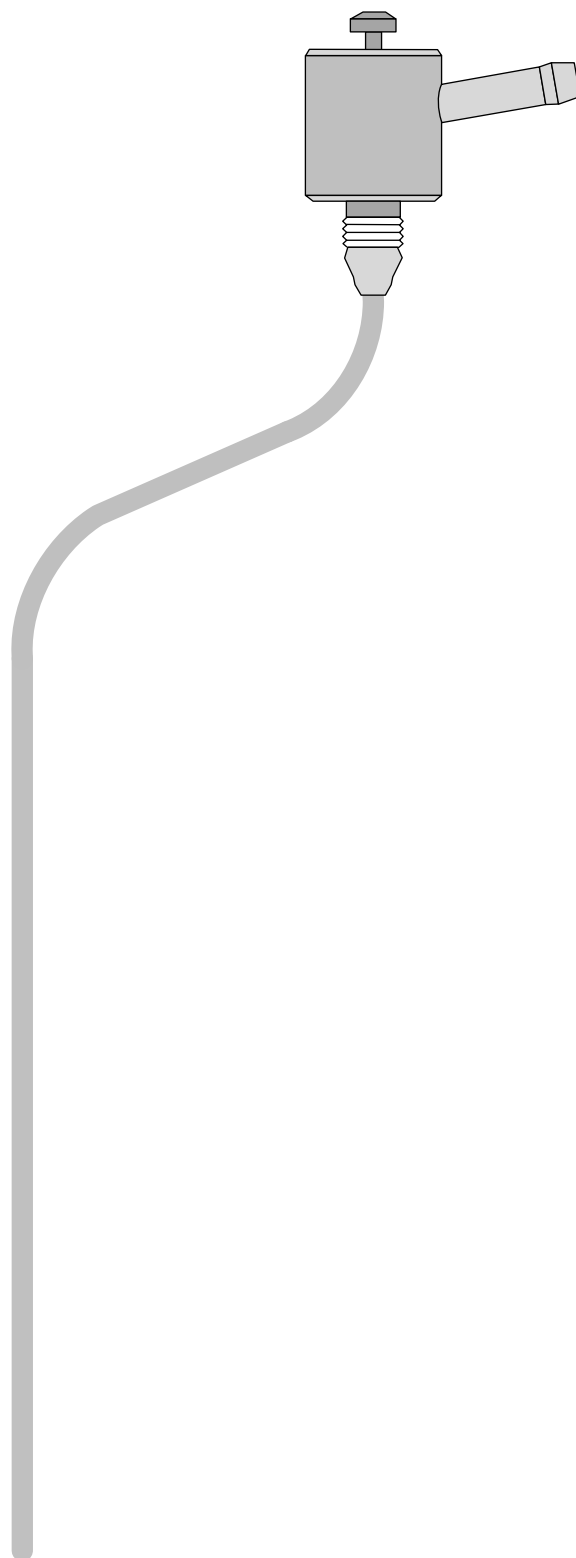
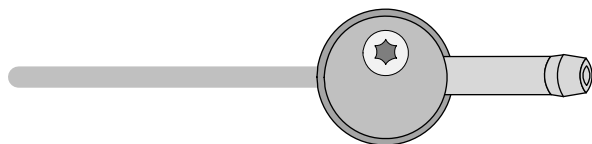

100mm



Scale 1:1

Compare size of printout with dimension lines.
Maximum permitted tolerance 2%.

Set the printer settings to 'no margin' or 'minimise margins' and 100% of the normal size.

100mm

0



FuelFix Template for 4Motion Diesel Vehicles

Top view

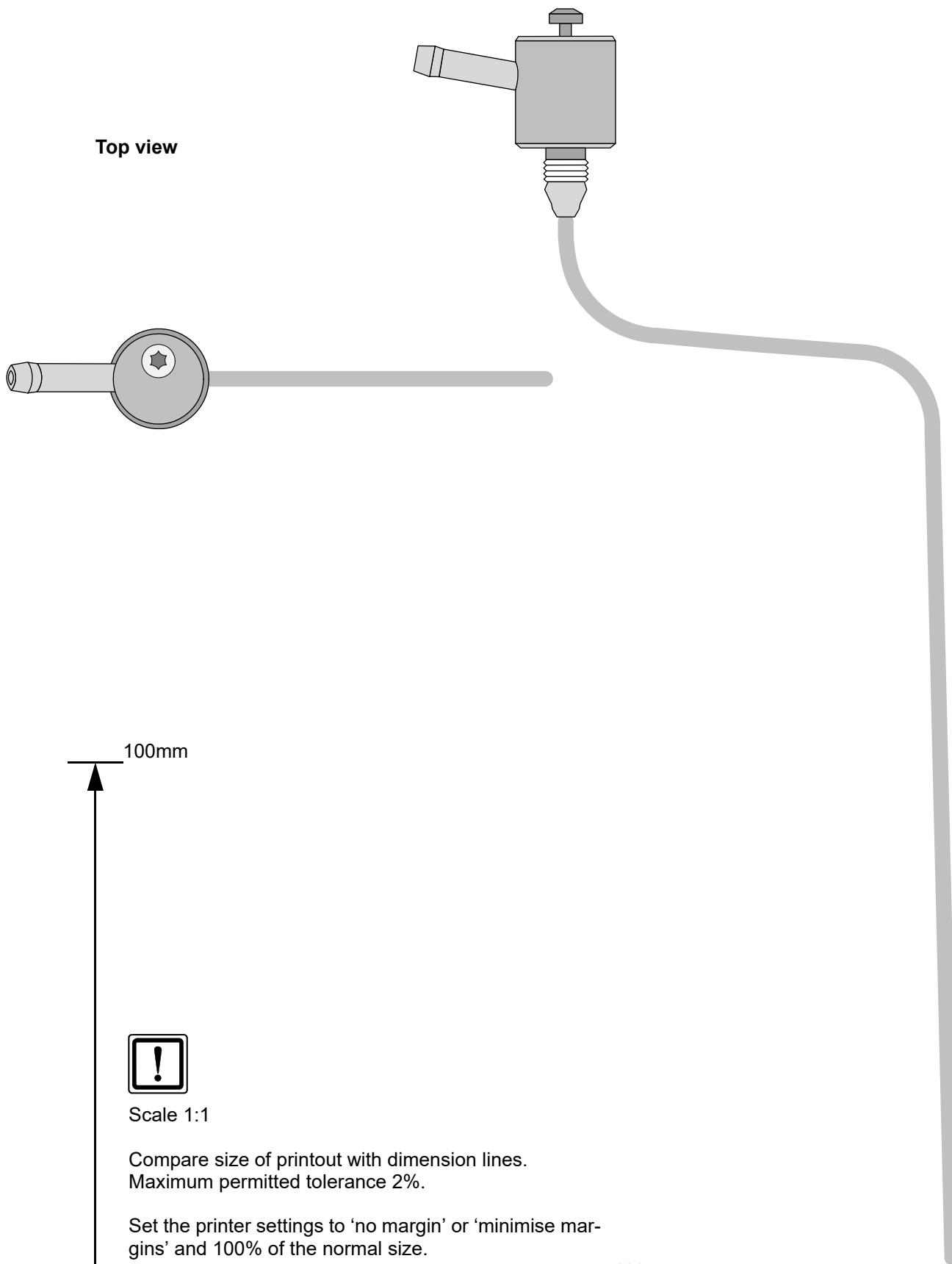

Scale 1:1

Compare size of printout with dimension lines.
Maximum permitted tolerance 2%.

Set the printer settings to 'no margin' or 'minimise margins' and 100% of the normal size.

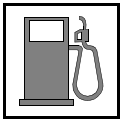

FuelFix Template for 2WD Petrol Vehicles

Top view

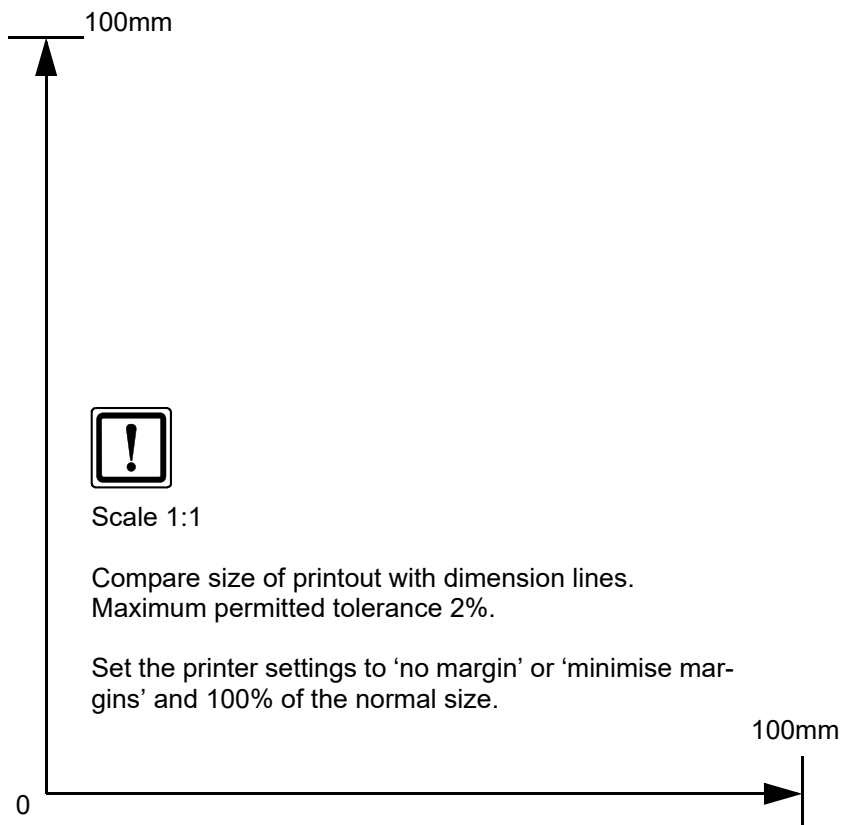
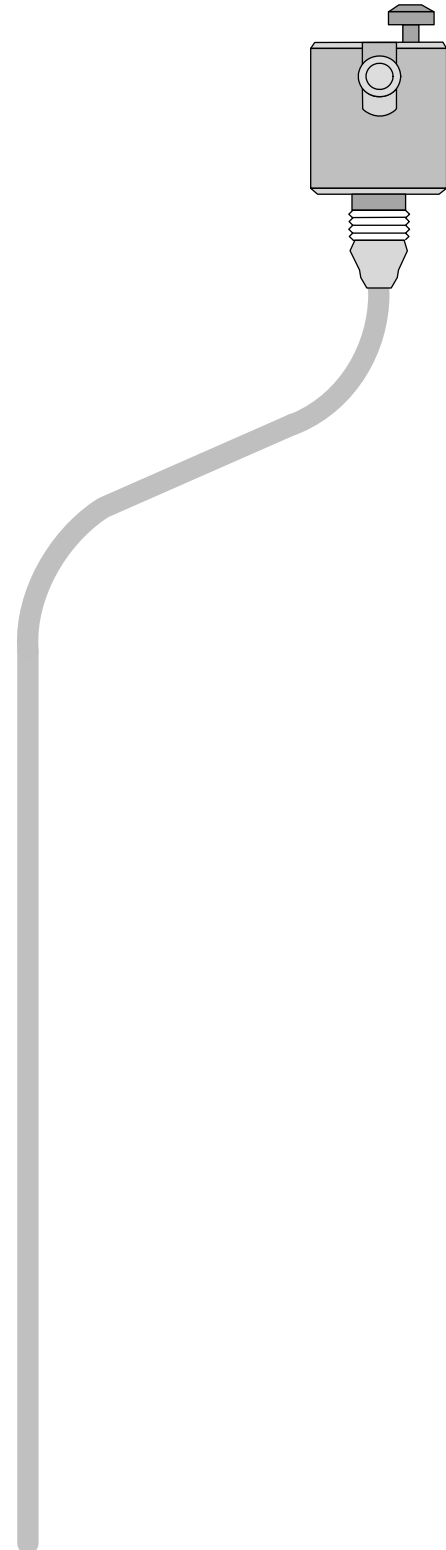
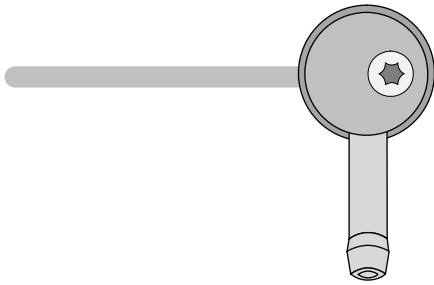



FuelFix Template for 4Motion Petrol Vehicles

Top view

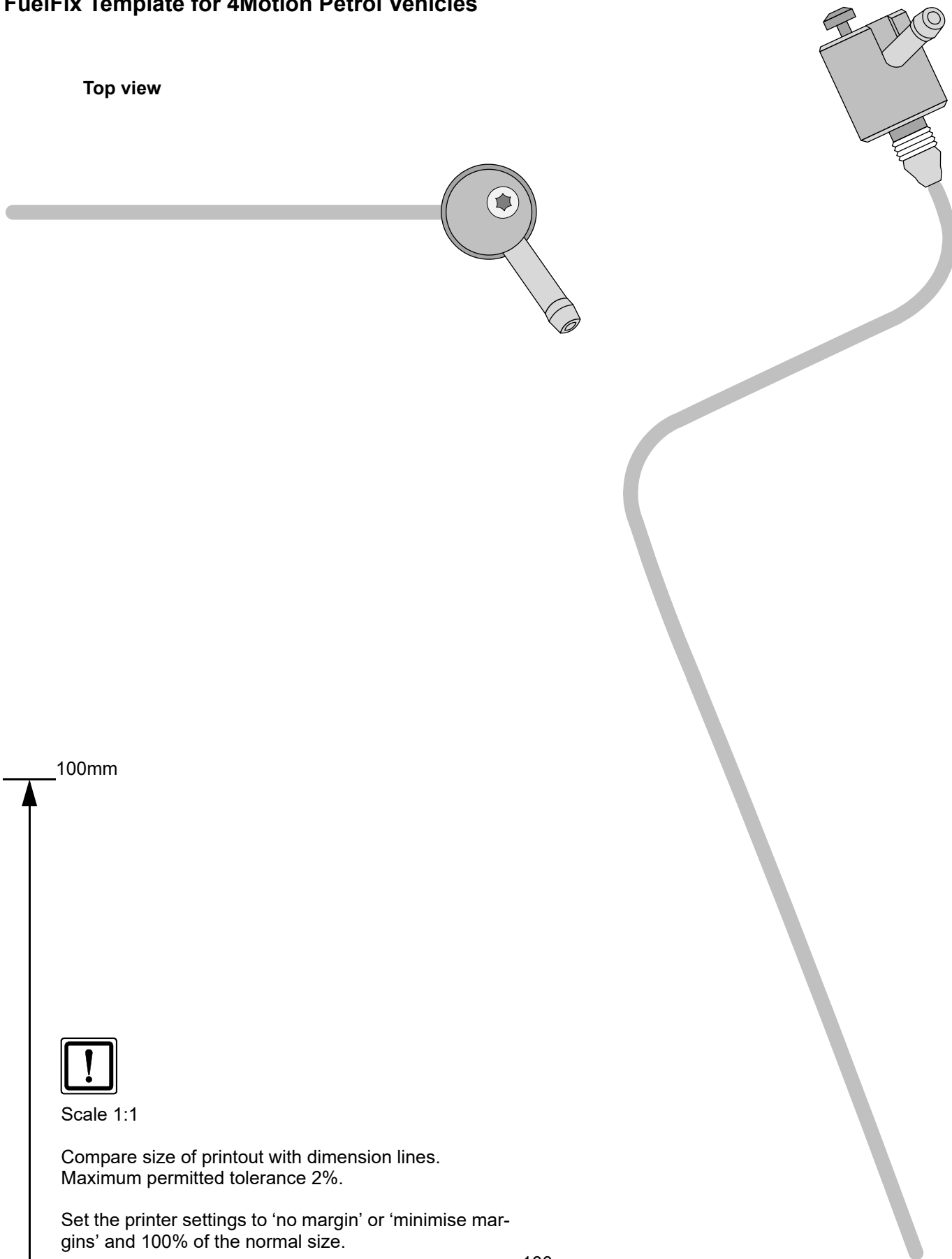

100mm



Scale 1:1

Compare size of printout with dimension lines.
Maximum permitted tolerance 2%.

Set the printer settings to 'no margin' or 'minimise margins' and 100% of the normal size.

100mm

0