



Water Heater

Thermo Top Evo Parking Heater



Installation Documentation Jeep Grand Cherokee V6

Validity

Manufacturer	Model	Type	Model year	EG BE No. / ABE
Jeep	Grand Cherokee V6	WK	From model year 2014	e4 * 2007 / 46 * 0186 * ...

Motorisation	Fuel	Emission standard	Transmission type	Output in kW	Displacement in cm ³	Engine code
3.6 V6	Petrol	Euro 5	AG	210	3604	ERB

AG = automatic transmission

Left-hand drive vehicle

Verified equipment variants: Automatic air-conditioning
Front fog lights
Headlight washer system

Not verified: Passenger compartment monitoring

Total installation time: about 11.5 hours

Jeep Grand Cherokee V6

Table of Contents

Validity	1	Preparing Bracket	9
Necessary Components	2	Preparing Installation Location	10
Installation Instructions	2	Preparing Heater	13
Information on Total Installation Time	2	Installing Heater	14
Information on Operating and Installation Instructions	3	Combustion Air	16
Information on Validity	4	Coolant Circuit	17
Technical Information	4	Fuel	19
Explanatory Notes on Document	4	Exhaust Gas	23
Preliminary Work	5	Final Work	25
Heater Installation Location	5	Fuel Tank Sending Unit Template	26
Electrical System	6	Fuel Standpipe Template	27
Air-Conditioning Control	7		
Heater Control Installation	7		
MultiControl CAR Option	7		
Remote Option (Telestart)	7		
ThermoCall Option	8		

Necessary Components

Description	Order No.:
Basic delivery scope of Thermo Top Evo	In accordance with price list
Installation kit for Jeep Grand Cherokee 2014 Petrol V6 and diesel	1325292A
Additional kit 'Webasto Comfort' A/C control for Jeep Grand Cherokee	1325260A
In case of Telestart, heater control, as well as indicator lamp in consultation with end customer	In accordance with price list
In case of MultiControl CAR installation - MultiControl installation frame	9030077_

Webasto Individual Option

Description	Order No.:
Webasto Individual Auxiliary Heating additional kit	1320077_
Webasto Individual Quick additional kit	9030826_
Webasto Individual Select additional kit	9030828_

Installation Instructions

Arrange for the vehicle to be delivered with the tank only about ¼ full.

The installation location of the push button in case of Telestart or ThermoCall should be confirmed with the end customer.

Depending on the space required and the vehicle manufacturer's instructions, we recommend the use of a vehicle battery with a higher electrical capacity.

Information on Total Installation Time

The total installation time includes the time needed for mounting and demounting the vehicle-specific components, the heater specific installation time and all other times required for the system integration and initial start-up of the heater.

The total installation time may vary for vehicle equipment other than provided.

Information on Operating and Installation Instructions

1 Important information (not complete)

1.1 Installation and repair



The improper installation or repair of Webasto heating and cooling systems can cause fire or the leakage of deadly carbon monoxide, leading to serious injury or death.



To install and repair Webasto heating and cooling systems you need to have completed a special company training course and have the appropriate technical documentation, special tools and special equipment.



Installation and repair may ONLY be carried out by persons trained and certified in a Webasto training course. NEVER try to install or repair Webasto heating or cooling systems if you have not completed a Webasto training course, you do not have the necessary technical skills and you do not have the technical documentation, tools and equipment available to ensure that you can complete the installation and repair work properly.

Only use genuine Webasto parts. See the Webasto air and water heaters accessories catalogue for this purpose.

1.2 Operation

To ensure safe operation, we recommend having the heater checked every two years by an authorised Webasto dealer, especially when used over a long period and/or under extreme environmental conditions.

Do not operate the heater in closed rooms due to the danger of poisoning and suffocation.

Always switch off the heater before refuelling.

The heater may only be used with the prescribed fuel diesel (DIN EN 590) or petrol (DIN EN 228).

The heater may not be cleaned with a high-pressure cleaner.

1.3 Please note

ALWAYS follow all Webasto installation and operating instructions and observe all warnings.

To become familiar with and understand all functions and properties of the heater, the operating instructions must be read carefully and observed at all times.

For proper, safe installation and repair work, the installation instructions with all warnings and safety information must be carefully read and observed at all times. Please always contact a workshop authorised by Webasto for all installation and repair work.

Important

Webasto shall assume no liability for defects, damage and injuries resulting from a failure to observe the installation, repair and operating instructions of the information contained in them.

This liability exclusion particularly applies to improper installations and repairs, installations and repairs by untrained persons or in the case of a failure to use genuine spare parts.

The liability due to culpable disregard to life, limb or health and due to damage or injuries caused by a wilful or reckless breach of duty remain unaffected, as does the obligatory product liability.

Installation should be carried out according to the general, standard rules of technology. Unless specified otherwise, fasten hoses, lines and wiring harnesses to original vehicle lines and wiring harnesses using cable ties. Insulate loose wire ends and tie back. Connectors on electronic components have to audibly click into place during installation.

Sharp edges should be fitted with rub protection. Spray unfinished body areas, e.g. drilled holes, with anti-corrosion wax (Tectyl 100K).

Observe the instructions and guidelines of the respective vehicle manufacturer for demounting and mounting vehicle specific components!

The initial startup is to be executed with the Webasto Thermo Test Diagnosis.

When installing a programmable control module (e.g. a PWM Gateway), the corresponding settings must be checked or adjusted.

2 Statutory regulations governing installation

Guidelines	Thermo Top Evo
Heating Directive ECE R122	E1 00 0258
EMC Directive ECE R10	E1 04 5627

Note

The regulations of these guidelines are binding in the scope of the Directive 70/156/EEC and/or 2007/46/EC (for new vehicle models from 29/04/2009) and should also be observed in countries in which there are no special regulations.

Important

Failure to follow the installation instructions will result in the invalidation of the type approval for the heater and therefore invalidation of the general **homologation of the vehicle**.

Note

The heater is licensed in accordance with paragraph 19, section 3, No. 2b of the StVZO (German Road Traffic Licensing Authority).

2.1 Excerpt from ECE regulation 122 (heating system) paragraph 5 for the installation of the heater

Beginning of excerpt.

ANNEX VII

REQUIREMENTS FOR COMBUSTION HEATERS AND THEIR INSTALLATION

1. GENERAL REQUIREMENTS

1.7.1. A clearly visible tell-tale in the operator's field of view shall inform when the combustion heater is switched on or off.

2. VEHICLE INSTALLATION REQUIREMENTS

2.1. Scope

2.1.1. Subject to paragraph 2.1.2, combustion heaters shall be installed according to the requirements of this Annex.

2.1.2. Vehicles of category O having liquid fuel heaters are deemed to comply with the requirements of this Annex.

2.2. Positioning of heater

2.2.1. Body sections and any other components in the vicinity of the heater must be protected from excessive heat and the possibility of fuel or oil contamination.

2.2.2. The combustion heater shall not constitute a risk of fire, even in the case of overheating. This requirement shall be deemed to be fulfilled if the installation ensures an adequate distance to all parts and suitable ventilation, by the use of fire resistant materials or by the use of heat shields.

2.2.3. In the case of M2 and M3 vehicles, the heater must not be positioned in the passenger compartment. However, an installation in an effectively sealed envelope which also complies with the conditions in paragraph 2.2.2 may be used.

2.2.4. The label referred to in paragraph 1.4 or a duplicate, must be positioned so that it can be easily read when the heater is installed in the vehicle.

2.2.5. Every reasonable precaution should be taken in positioning the heater to minimise the risk of injury and damage to personal property.

2.3. Fuel supply

2.3.1. The fuel filler must not be situated in the passenger compartment and must be provided with an effective cap to prevent fuel spillage.

2.3.2. In the case of liquid fuel heaters, where a supply separate to that of the vehicle is provided, the type of fuel and its filler point must be clearly labelled.

2.3.3. A notice, indicating that the heater must be shut down before refuelling, must be affixed to the fuelling point. In addition a suitable instruction must be included in the manufacturer's operating manual.

2.4. Exhaust system

2.4.1. The exhaust outlet must be located so as to prevent emissions from entering the vehicle through ventilators, heated air inlets or opening windows.

2.5. Combustion air inlet

2.5.1. The air for the combustion chamber of the heater must not be drawn from the passenger compartment of the vehicle.

2.5.2. The air inlet must be so positioned or guarded that blocking by rubbish or luggage is unlikely.

2.6. Heating air inlet

2.6.1. The heating air supply may be fresh or recirculated air and must be drawn from a clean area not likely to be contaminated by exhaust fumes emitted either by the propulsion engine, the combustion heater or any other vehicle source.

2.6.2. The inlet duct must be protected by mesh or other suitable means.

2.7. Heating air outlet

2.7.1. Any ducting used to route the hot air through the vehicle must be so positioned or protected that no injury or damage could be caused if it were to be touched.

2.7.2. The air outlet must be so positioned or guarded that blocking by rubbish or luggage is unlikely.

End of excerpt.

In multilingual versions the German language is binding.

Jeep Grand Cherokee V6

Information on Validity

This installation documentation applies to Jeep Grand Cherokee V6 Petrol vehicles - for validity, see page 1 - from model year 2014 and later, assuming technical modifications to the vehicle do not affect installation, any liability claims excluded. Depending on the vehicle version and equipment, modifications may be necessary during installation with respect to this 'installation documentation'.

Vehicle and engine types, equipment variants and other specifications not listed in this installation documentation have not been tested. However, installation according to this installation documentation may be possible.

Technical Information

Special Tools

- Hose clamp pliers for auto-tightening hose clamps
- Hose clamp pliers for Clic hose clamps of type W
- Automatic wire stripper, 0.2 - 6mm²
- Crimping pliers for cable lug / tab connector, 0.5 - 6mm²
- Torque wrench for 2.0 - 10 Nm
- Hose clamping pliers
- Metric thread-setter kit
- Deep-hole marker
- Webasto Thermo Test Diagnosis with current software

Dimensions

- All dimensions are in mm.

Tightening torque values

- Tightening torque values of 5x13 heater bolts and 5x11 heater stud bolts = 8Nm.
- Tightening torque value of 5x15 water connection piece retaining plate bolt = 7Nm.
- Tighten other bolt connections in accordance with manufacturer's instructions or in accordance with state-of-the-art technology.

Explanatory Notes on Document

You will find an identification mark on the outside top right corner of the page in question to provide you with a quick overview of the individual working steps.

Mechanics

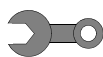

Electrics



Coolant Circuit



Combustion Air

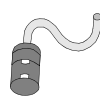

Fuel



Exhaust Gas



Software



Special features are highlighted using the following symbols:

Specific risk of damage to components.



Specific risk due to electrical voltage.



Specific risk of fire or explosion.



Reference to a special technical feature.



The arrow in the vehicle icon indicates the position on the vehicle and the viewing angle.

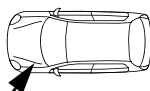

Reference to the manufacturer's vehicle-specific documents.



Reference to specific installation instructions of Webasto components (demonstrated with the example of the FuelFix).



Reference to general installation instructions of Webasto components.



Tightening torque according to the manufacturer's vehicle-specific documents.



Preliminary Work

Vehicle



- Open the fuel tank cap.
- Ventilate the fuel tank.
- Close the fuel tank cap again.
- Depressurise the cooling system.
- Disconnect the battery.
- Remove the exhaust pipe.
- Remove the heat protection trim of the cardan shaft.
- Remove the cardan shaft according to the manufacturer's instructions.
- Remove the fuel lines trim at the left on the underbody.
- Remove the fuel tank according to the manufacturer's instructions.
- Remove the fuel tank sending unit according to the manufacturer's instructions.
- Remove the lower engine cover.
- Drain the engine coolant.
- Remove the engine design cover.
- Remove the air filter box including the air ducting.
- Remove the footwell trim under the glove box.
- Remove the air outlet nozzle in the right footwell.
- Remove the trim of the entrance strip on the right side (for Telestart option only).
- Remove the lower A-pillar trim in the right footwell.
- Remove the A/C control panel.

Heater

- Remove years that do not apply from the type and duplicate label.
- Attach the duplicate label (type label) visibly in the appropriate place in the engine compartment.



Heater Installation Location

- 1 Heater

Installation location



Electrical System



Positive wire

- 1 Positive wire on original vehicle positive support point

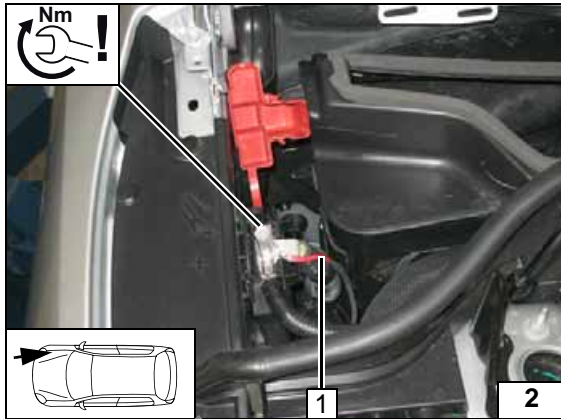

Wiring harness pass through

- 1 Cable grommet

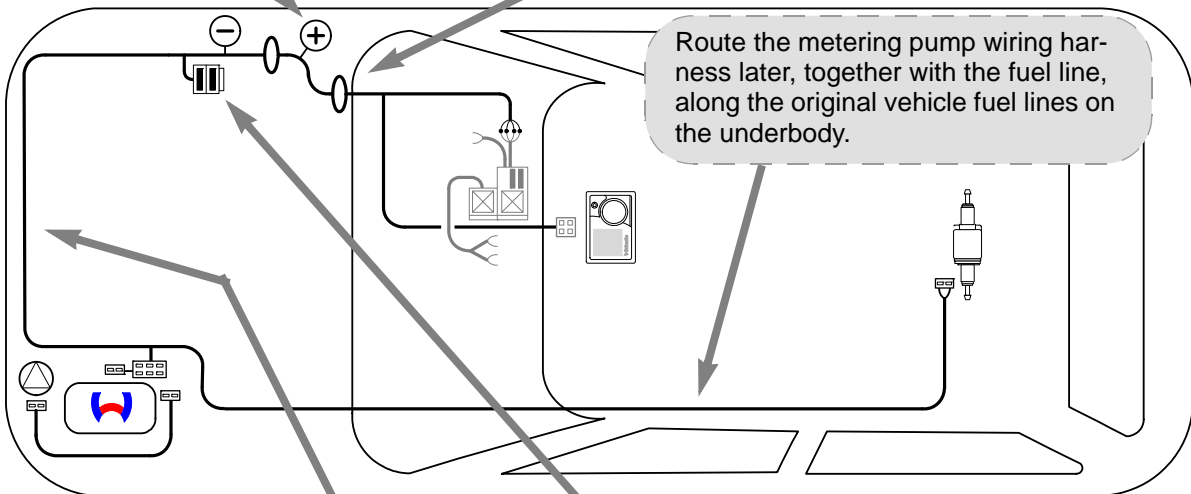
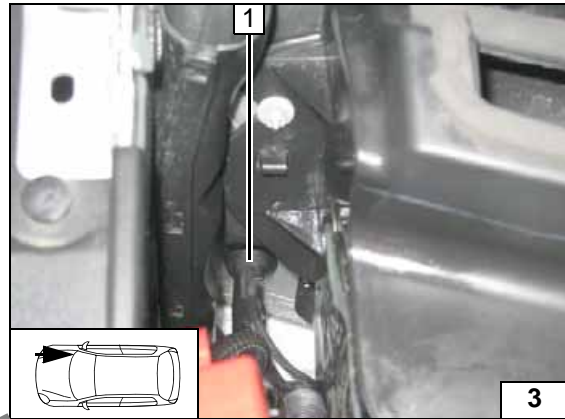

Wiring harness routing diagram

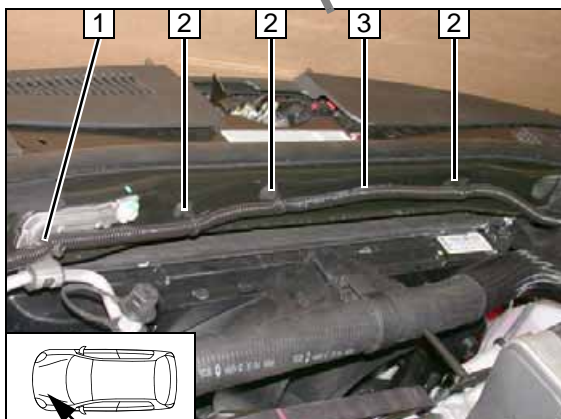

Wiring harness routing, engine compartment

- 1 Cable tie
- 2 Fastening clip with cable tie [3x]
- 3 Heater and metering pump wiring harnesses in 10mm dia., 2100mm long corrugated tube

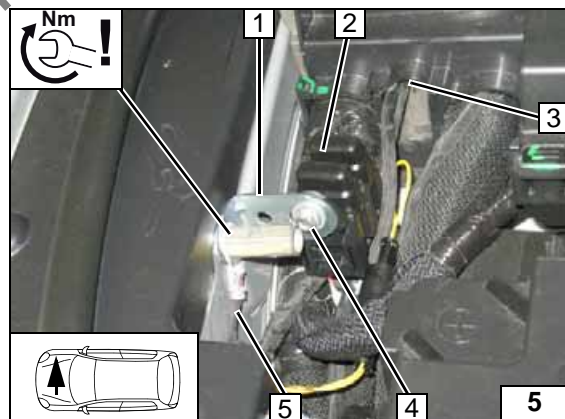

Fuse holder of engine compartment, earth wire

Mount earth wire 5 and angle bracket 1 on original vehicle earth support point.

- 2 Fuses F1-2
- 3 Cable pass through via partition wall
- 4 M5x16 bolt, washer [2x], retaining plate of fuse holder, nut





Air-Conditioning Control



Integrate the A/C control as explained in the separate installation documentation:

Installation documentation '**Webasto Comfort**' A/C control for Jeep Grand Cherokee AAC

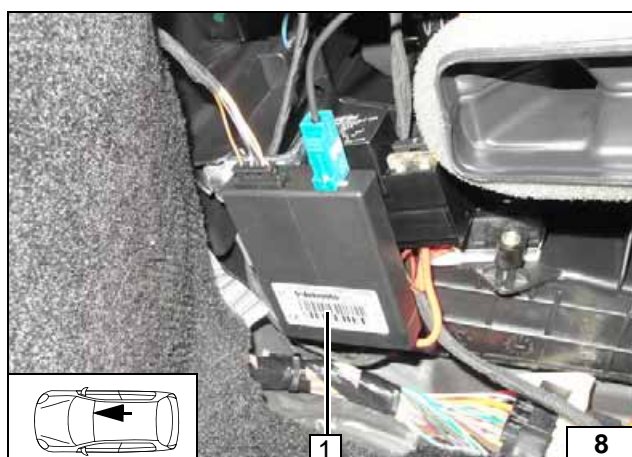
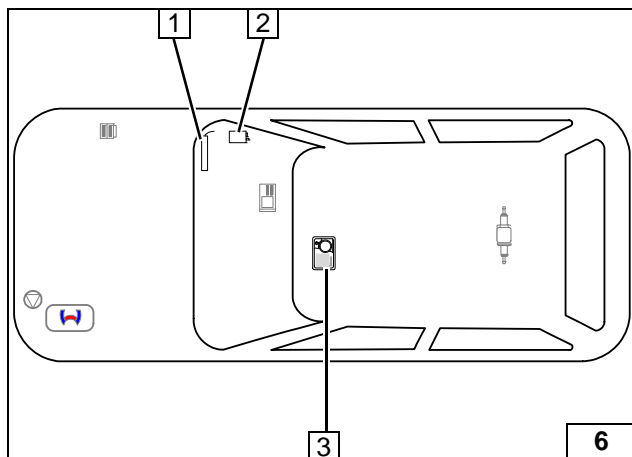

Heater Control Installation

- 1 Telestart / ThermoCall aerial
- 2 Telestart / ThermoCall receiver
- 3 MultiControl CAR

MultiControl CAR Option

- 1 Installation frame

Remote Option (Telestart)

Fasten receiver 1 with double-sided adhesive tape.



Installation overview



Installing MultiControl CAR



Installing receiver

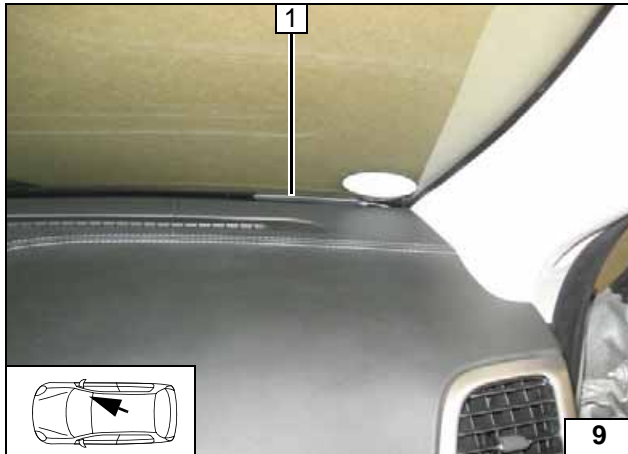

1 Aerial

Installing aerial

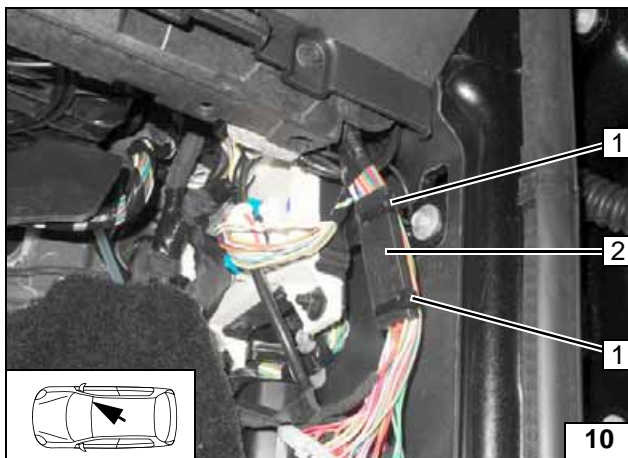

Temperature sensor T100 HTM

Fasten temperature sensor 2 with cable tie 1.



Installing temperature sensor

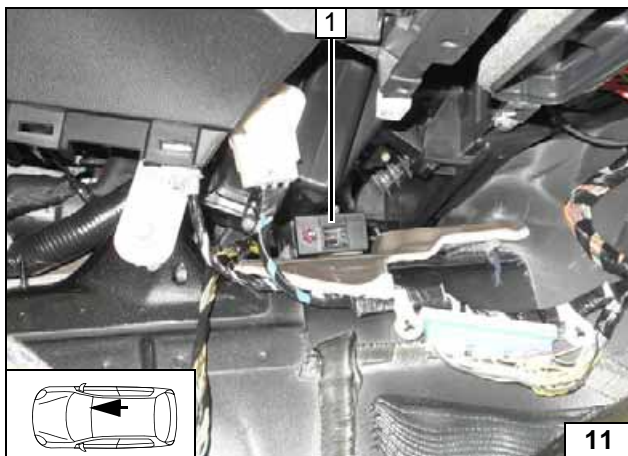

ThermoCall Option

Fasten receiver 1 with double-sided adhesive tape.



Installing receiver

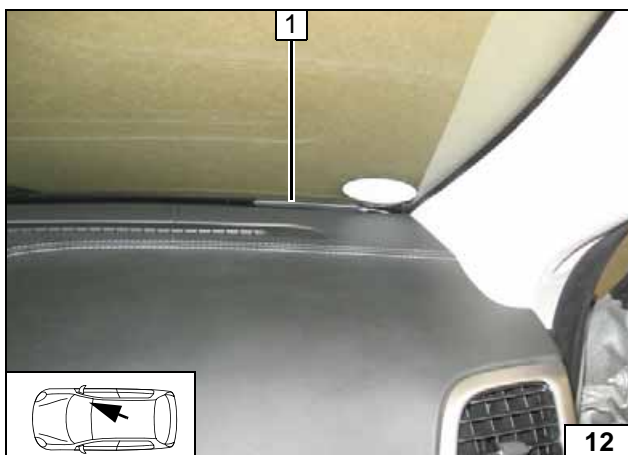

1 Aerial (optional)

Installing aerial

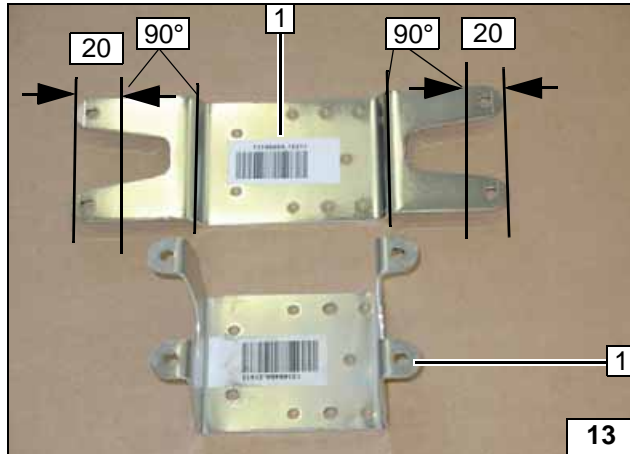
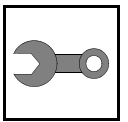

Preparing Bracket

- 1 Bracket

Angling down bracket

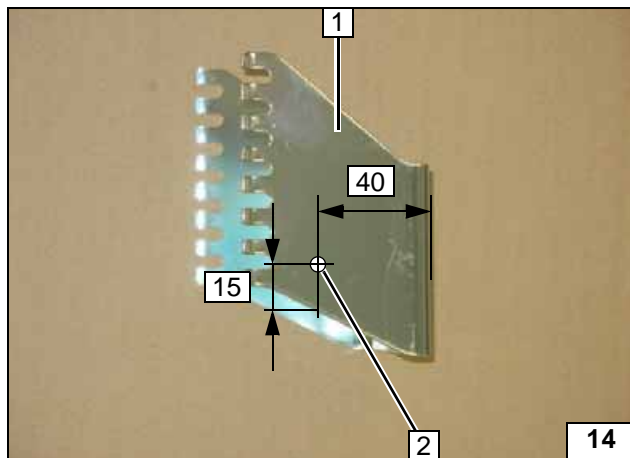

- 1 Bracket
- 2 7.0 mm dia. hole

Preparing bracket

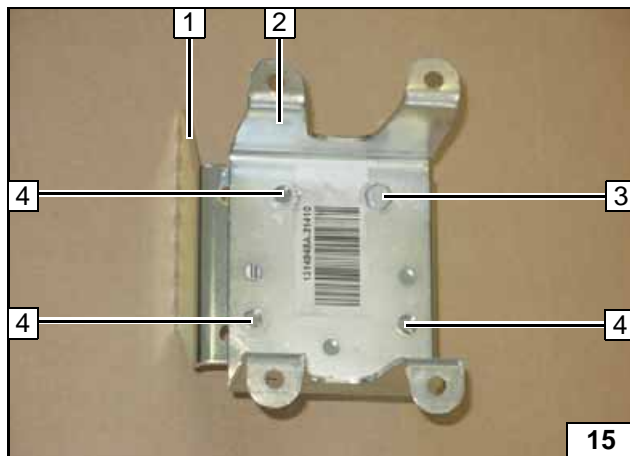

Align bracket 2 with bracket 1 and secure using M6x16 bolt and flanged nut 3. Copy hole pattern 4 onto 7mm dia. bracket 1 [3x] and drill.



Copying hole pattern

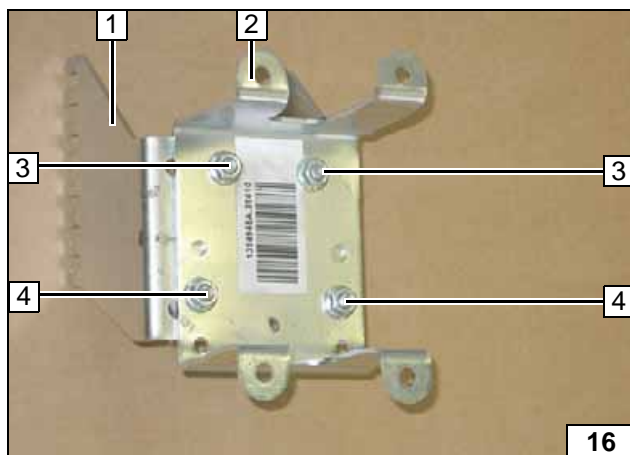

- 1 Bracket
- 2 Bracket
- 3 M6x16 bolt, nut [2x each]
- 4 M6x16 bolt, large diameter washer, nut [2x each]

Premounting bracket

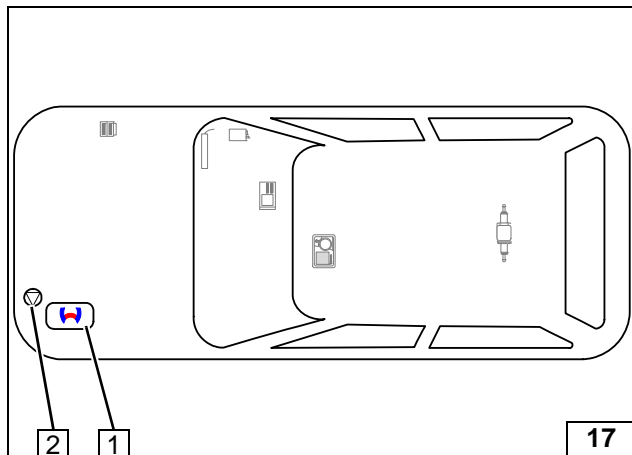
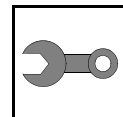

Preparing Installation Location

- 1 Heater
- 2 Circulating pump



Installation overview

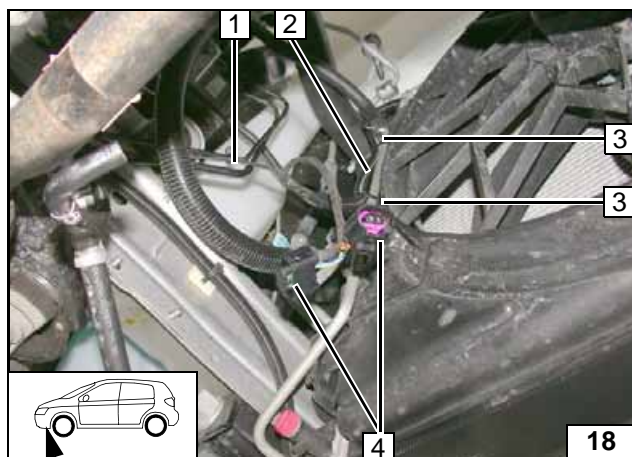

- 1 Wiring harness of metering pump
- 2 Heater wiring harness
- 3 Cable tie [2x]
- 4 Heater wiring harness connector

Routing wiring harnesses in engine compartment

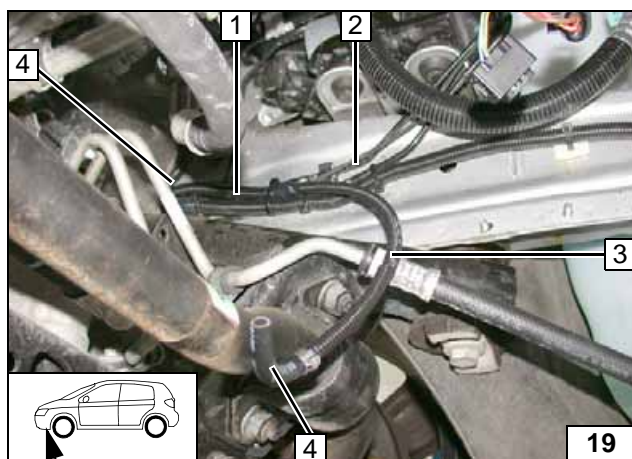

Route wiring harness of metering pump and 6000mm long fuel line together in 10mm dia. corrugated tube 1 behind heat protection trim 4 along the brake wires to the underbody.



- 2 Wiring harness of metering pump
- 3 10 mm dia. corrugated tube, fuel line
- 4 90° moulded hose

Installing bracket

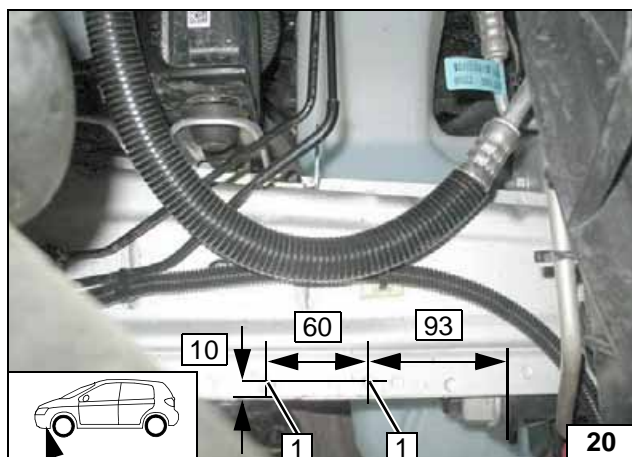

- 1 7mm dia. hole [2x]

Hole in frame side member

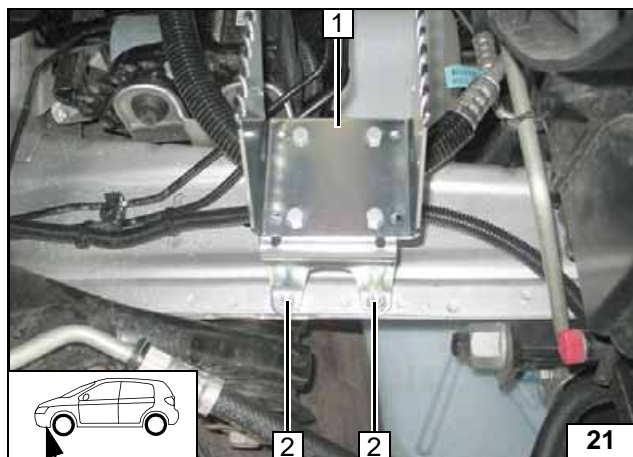

Mount bracket 1 with M6x16 bolt 2 [2x] and flanged nut [2x].



Copying hole pattern

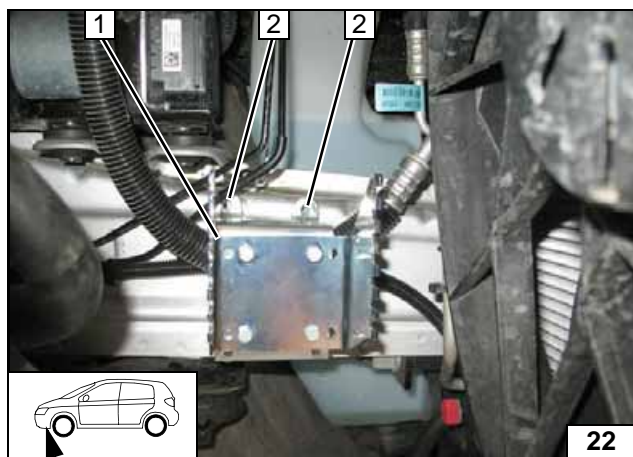

Align bracket 1 copy hole pattern 2 [2x]. Disassemble bracket again.



Copying hole pattern

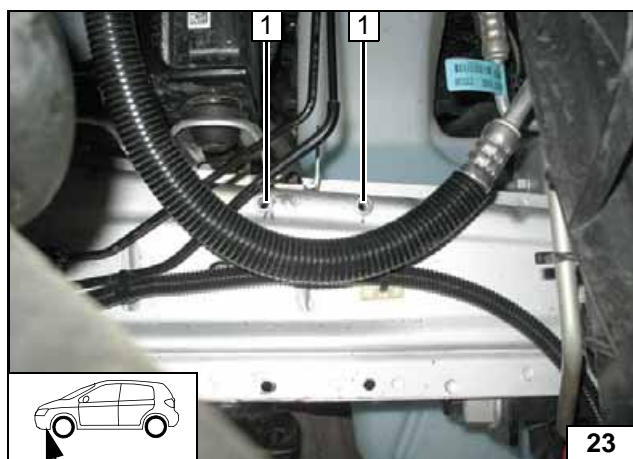

1 9mm dia. holes, M6 rivet nut [2x each]

Installing rivet nuts

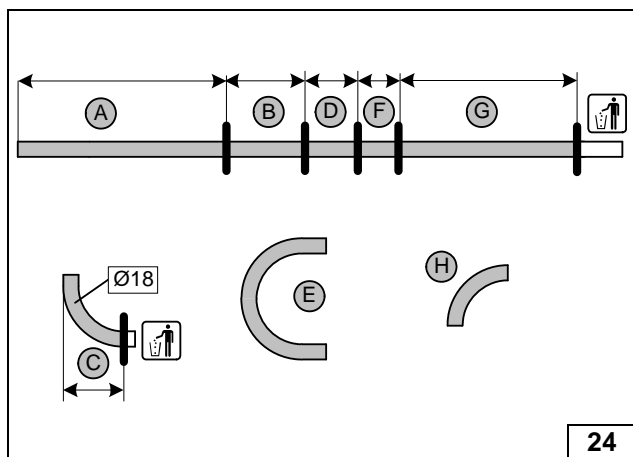

- A = 630
- B = 120
- C = 55
- D = 70
- E = 180°, 18x18mm dia.
- F = 60
- G = 530
- H = 90°, 15x18mm dia.

Cutting hoses to length

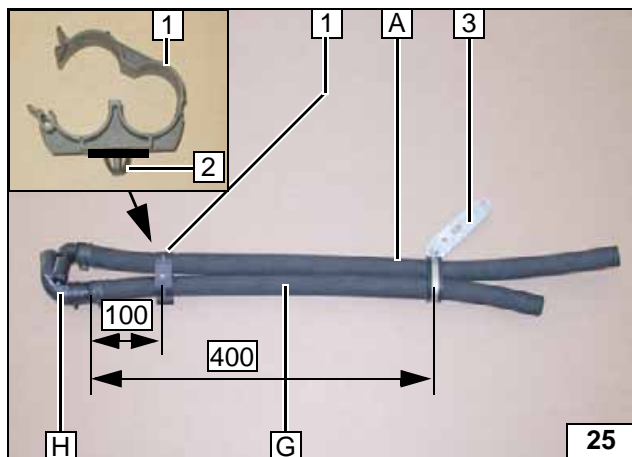

Separate retaining clip 2 from hose bracket 1.



- 1 Hose bracket
- 3 Perforated bracket, 38 mm dia. rubber-coated clamp, M6x16 bolt, flanged nut

Premounting coolant hoses A, G and H

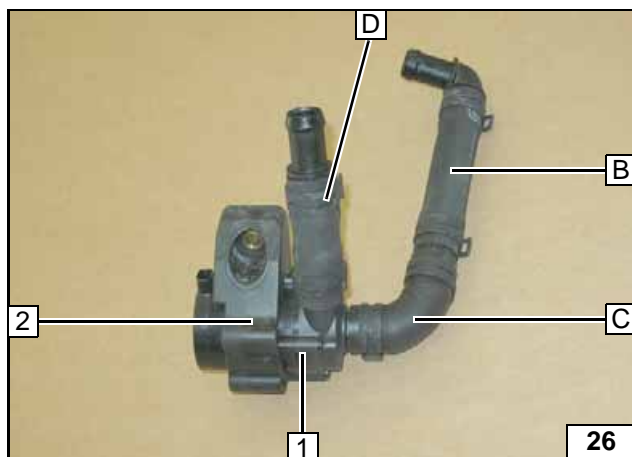

All spring clips, 25 mm dia.
All connecting pipes, 18x18 mm dia.



- 1 Circulating pump
- 2 Circulating pump mount

Premounting circulating pump

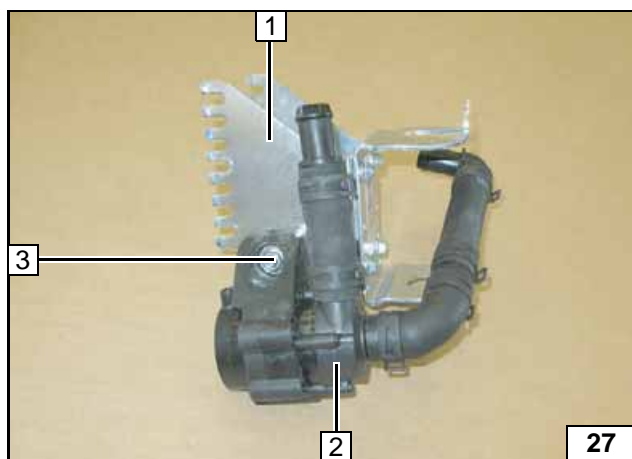

- 1 Bracket of heater
- 2 Circulating pump pre-mounted
- 3 M6x25 bolt, washer, flanged nut

Premounting bracket and circulating pump

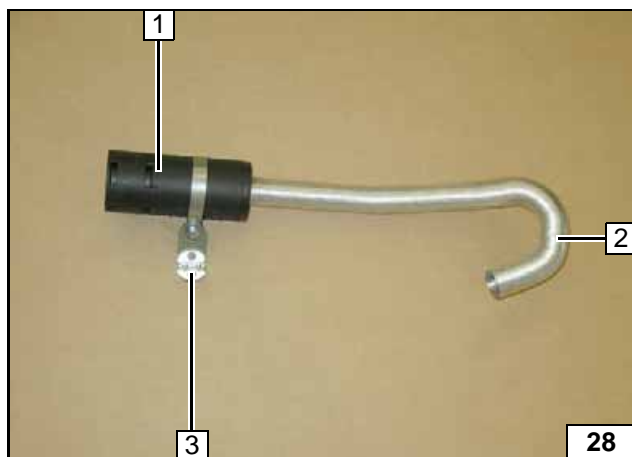

- 1 Silencer
- 2 Intake pipe
- 3 Angle bracket, M5x16 bolt, nut, large diameter washer, 51 mm dia. clamp

Premounting silencer

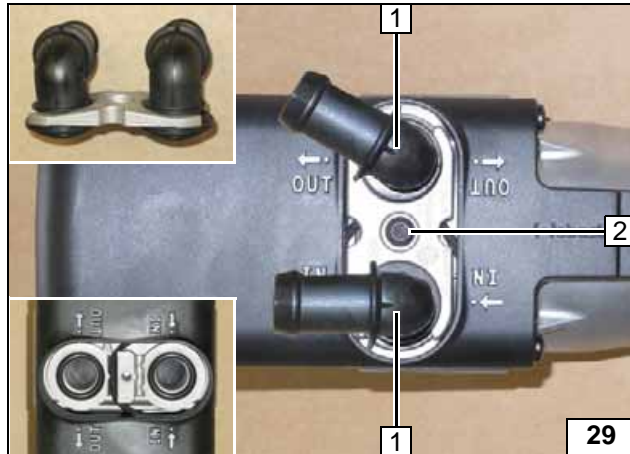
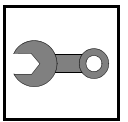

Preparing Heater

- 1 Water connection piece, sealing ring [2x each]
- 2 5x15 self-tapping bolt, retaining plate of water connection piece



Installing water connection piece

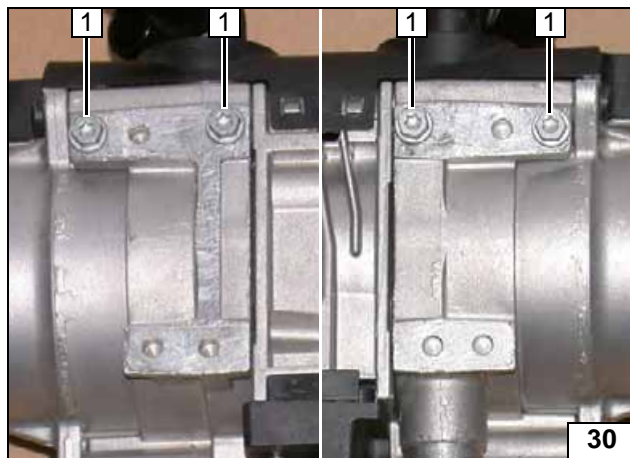

Screw 5x13 self-tapping bolts 1 [4x] into existing holes by a maximum of 3 thread turns.



Premounting bolts loosely

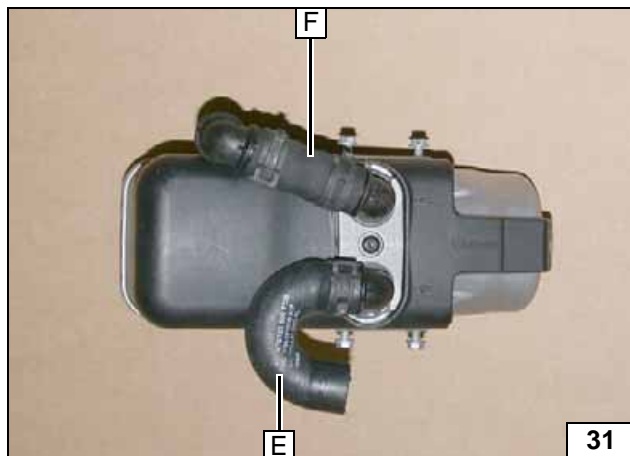

All spring clips, 25 mm dia. 18x18 connecting pipe.



Mounting hoses E and F

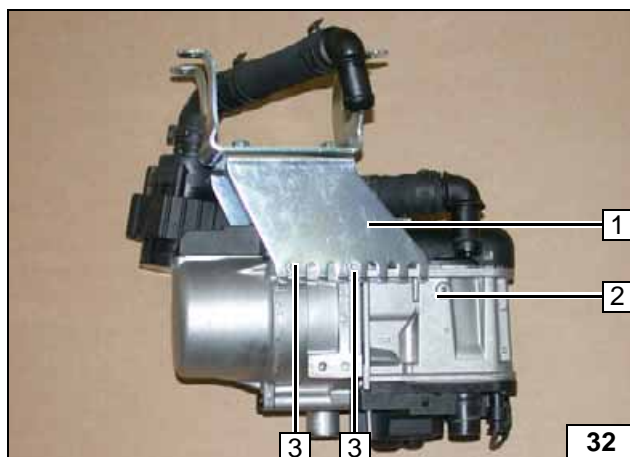

Insert heater 2 in bracket 1 as shown and tighten 5x13 self-tapping bolt 3 [2x].



Installing bracket on heater

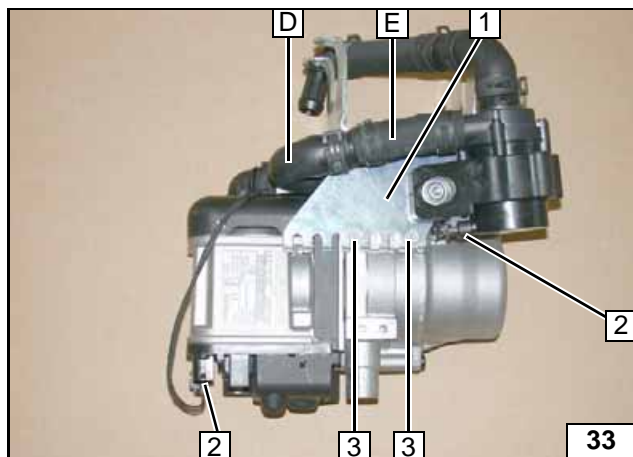
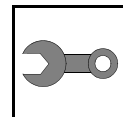

Connect hoses **D** and **E**.

- 1 Bracket
- 2 Install circulating pump wiring harness
- 3 Tighten 5x13 self-tapping bolts [2x]



Installing bracket on heater



- 1 Intake pipe

Premounting combustion air pipe

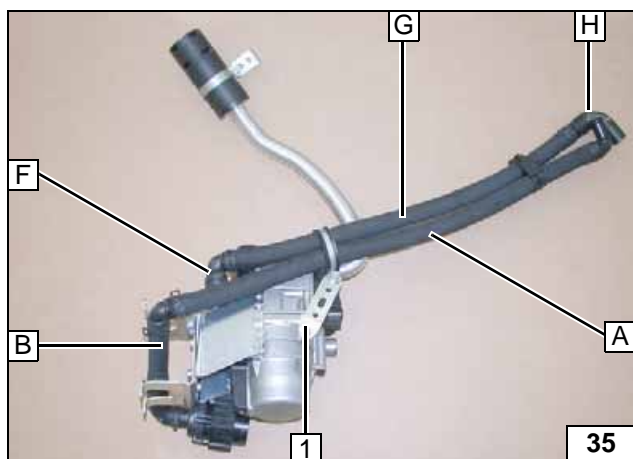

- 1 5x13 self-tapping bolts, perforated bracket

Mounting hoses A and G

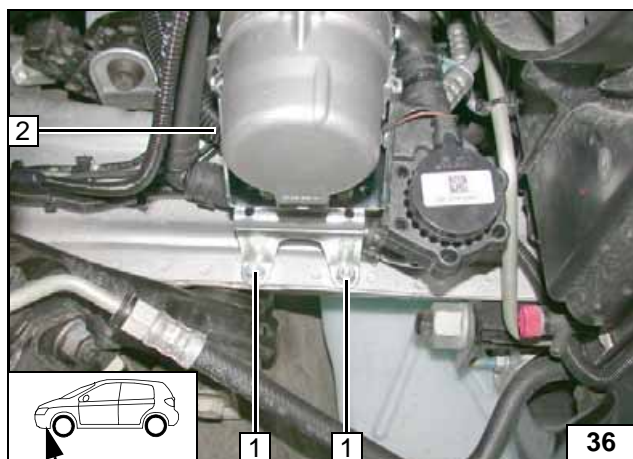

Installing Heater

Align A/C line **2** within the bracket.

- 1 M6x16 bolt, flanged nut



Installing heater

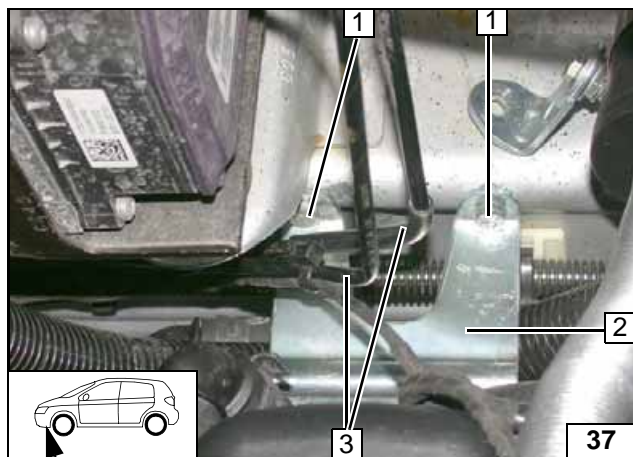

Align brake lines **3**.

- 1 M6x20 bolt, spring lockwasher
- 2 Bracket with heater premounted



**Installing
heater**

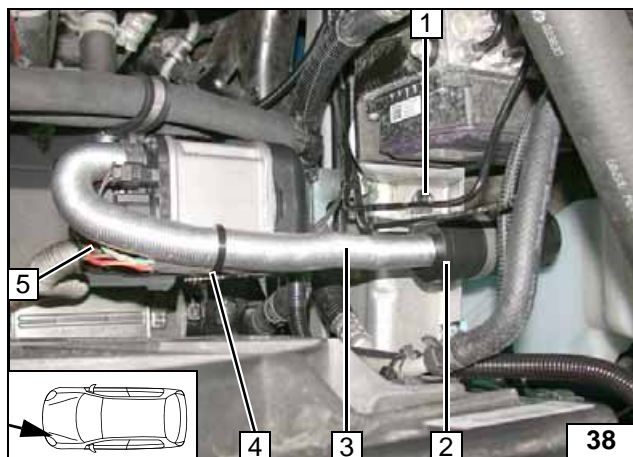
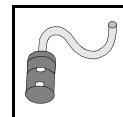

Combustion Air

Align silencer 2 and install with plastic nut 1 on original vehicle stud bolt.

- 3 Intake pipe
- 4 Cable tie, wiring harness of heater
- 5 Plug connector [2x] of heater wiring harness into heater



Installing silencer

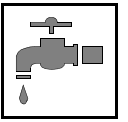

Coolant Circuit





Any coolant running off should be collected in an appropriate container. Route hoses kink-free. Unless specified otherwise, always fasten using cable ties. Position clamps so that other hoses cannot be damaged. The heater must be filled with coolant when installing the hoses.

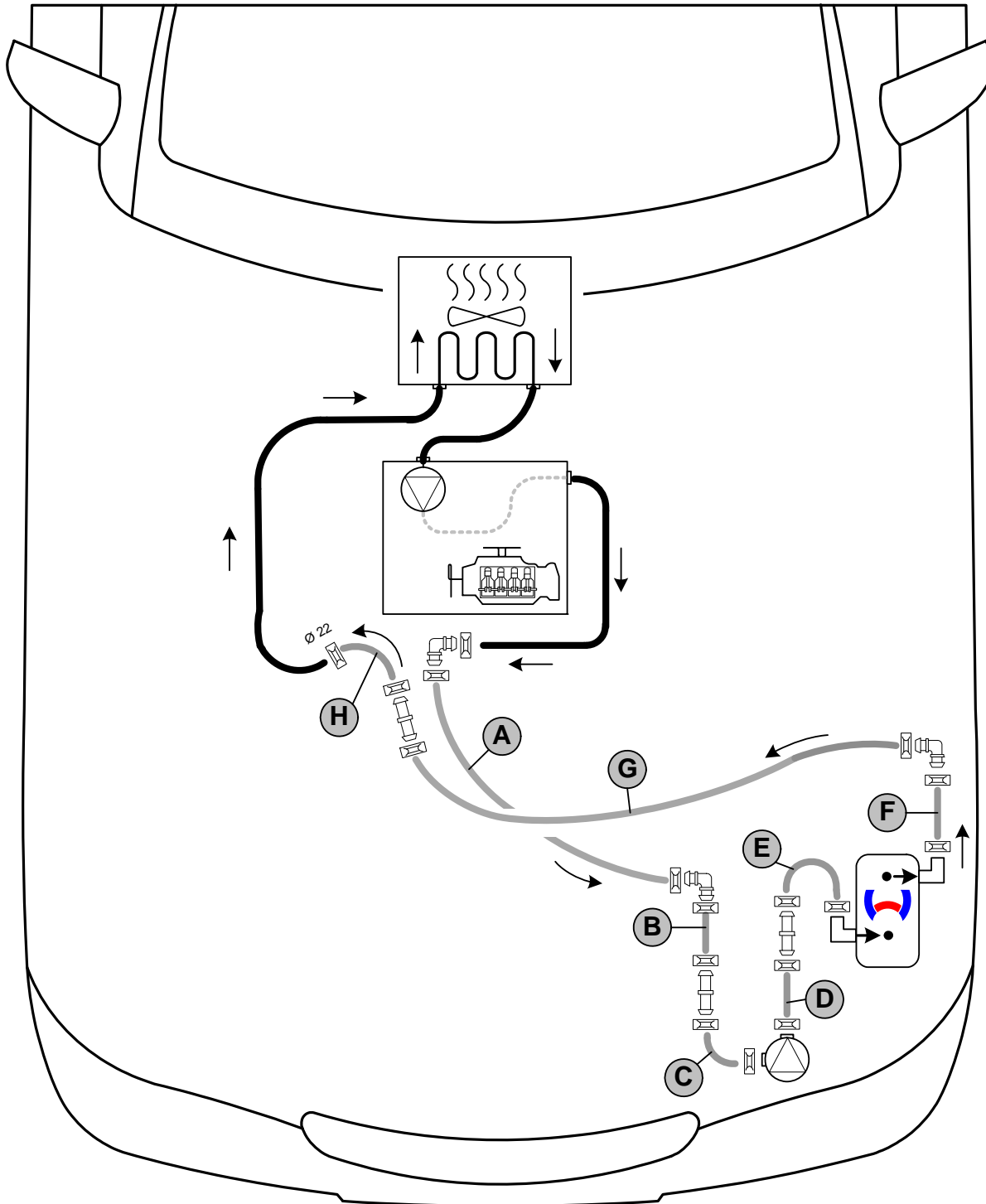

The connection should be modelled on an 'inline' circuit and based on the following diagram:



Hose routing diagram

All spring clips without a specific designation  = 25 mm dia.
 All connecting pipes without a specific designation  = 18x18mm dia.
 All connecting pipes without a specific designation  = 18x18 mm dia.



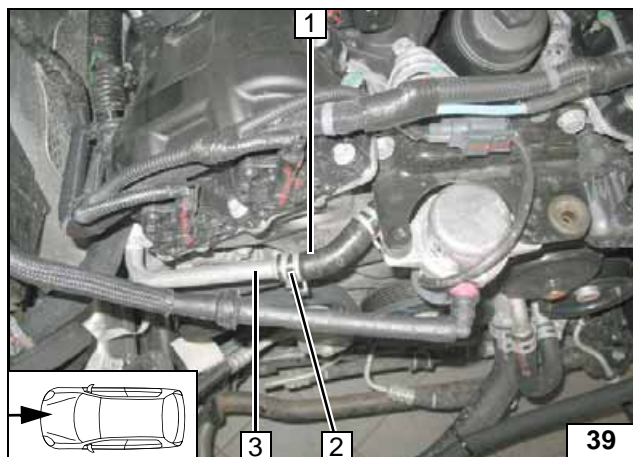

Pull hose end at engine outlet **1** off pipe **3**, the original vehicle spring clip **2** will not be reused.



Cutting point

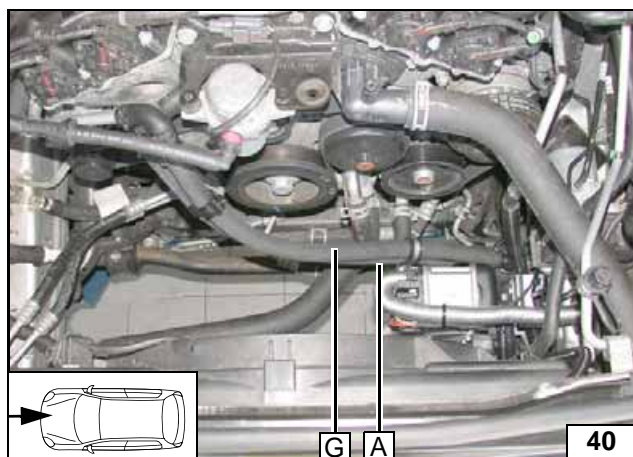

Route hoses **A** and **G** to the connecting point.



Routing in engine compartment

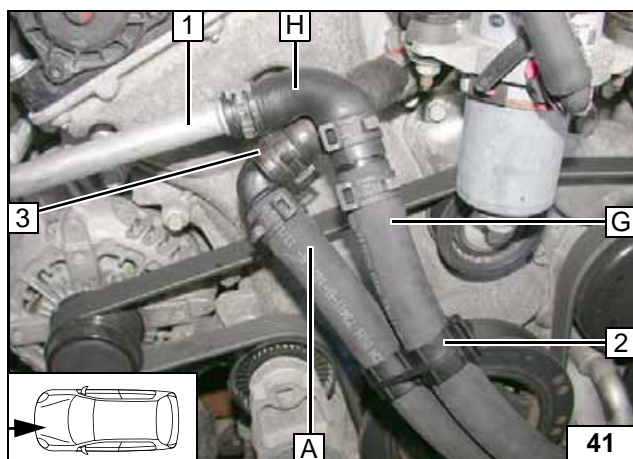

Ensure sufficient distance from neighbouring components.

Align hose bracket **2**.

- 1** Pipe on heat exchanger inlet
- 3** Engine outlet hose section



Connecting engine outlet and heat exchanger inlet

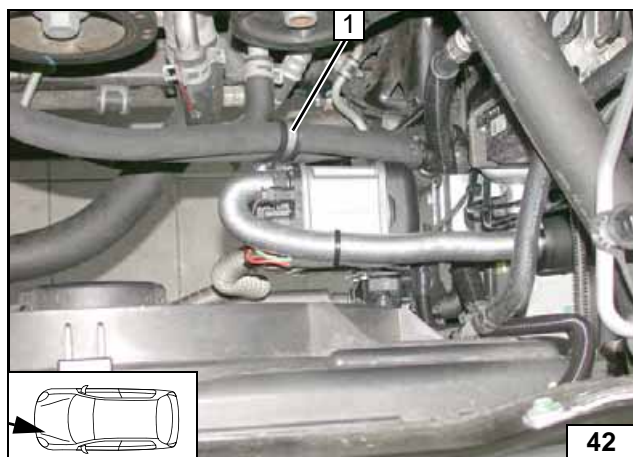

Ensure sufficient distance from neighbouring components.

- 1** 38 mm dia. rubber-coated p-clamp

Routing in engine compartment



Fuel



Open the vehicle's fuel tank cap, ventilate the tank and then re-close the tank lock.

Catch any fuel running off in an appropriate container.

Route fuel line and metering pump wiring harness so that they are protected against stone impact. Unless specified otherwise, always fasten using cable ties.



Provide rub protection for fuel line and wiring harness in areas where there are sharp edges.

The fuel line and wiring harness are routed to the metering pump as shown in the wiring harness routing diagram.

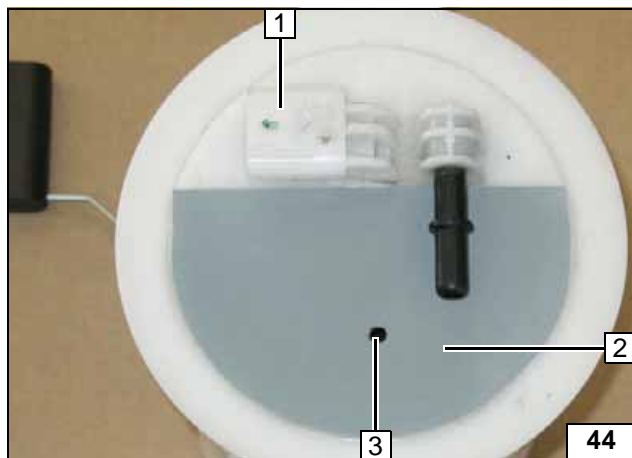
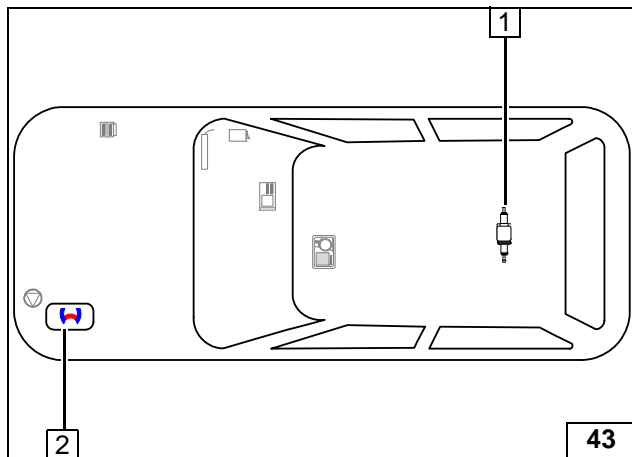

Remove the tank according to the manufacturer's instructions. Remove fuel tank sending unit **1** according to the manufacturer's instructions. Cut out template of fuel tank sending unit **2** and apply.

3 Copy hole pattern, 6mm dia. hole

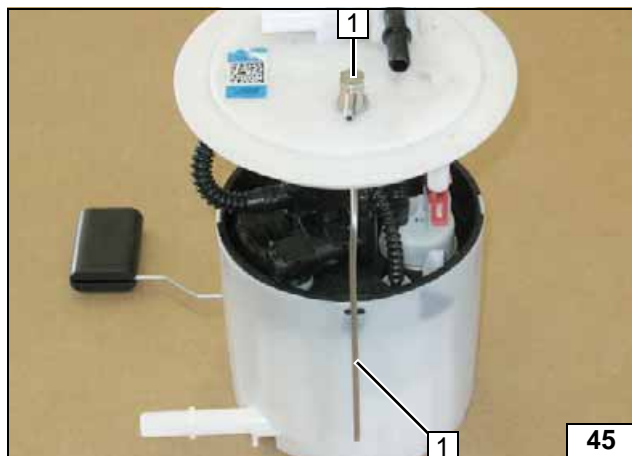

Bend fuel standpipe **1** according to template and cut to length.



Installation overview



Fuel extraction



Installing fuel standpipe

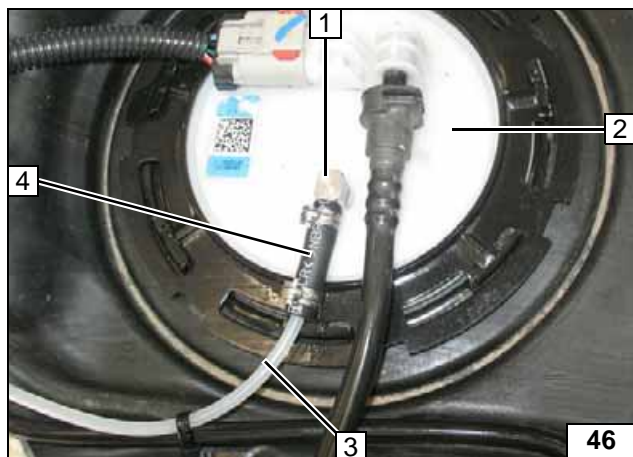
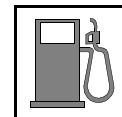

Install fuel tank sending unit **2** according to the manufacturer's instructions.

- 1 Fuel standpipe
- 3 Fuel line
- 4 Hose section, 10mm dia.clamp [2x]



Connecting fuel line

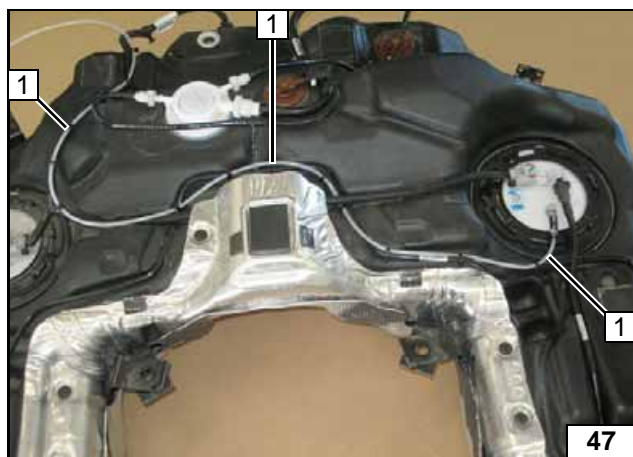

Install tank after routing according to manufacturer's instructions.

- 1 Fuel line



Routing fuel line

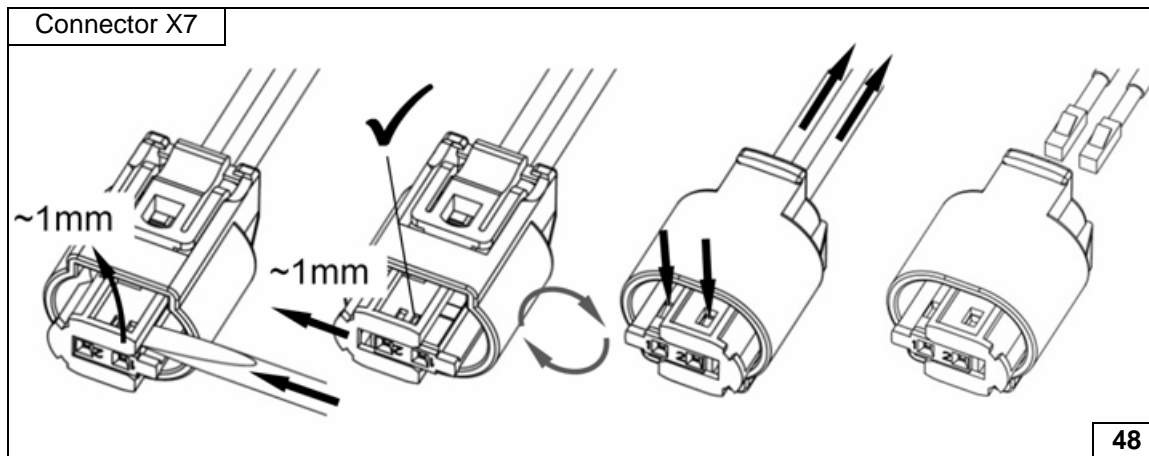

Dismantling metering pump connector

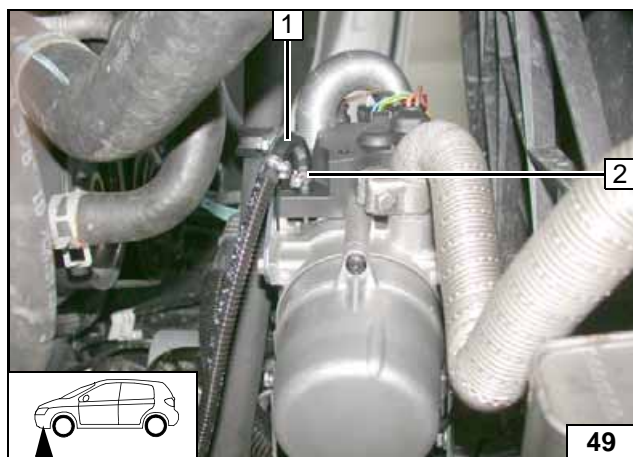

- 1 90° moulded hose, fuel line
- 2 10 mm dia. clamp



Connecting heater



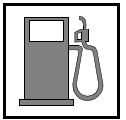

Route fuel line and wiring harness of metering pump in corrugated tube 1 on original vehicle lines to the rear.



Routing lines

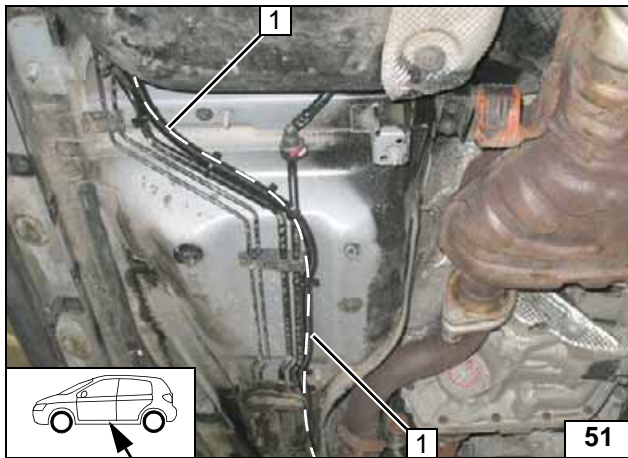

Route fuel line and wiring harness of metering pump in corrugated tube 1 on original vehicle lines to the tank.



Routing lines

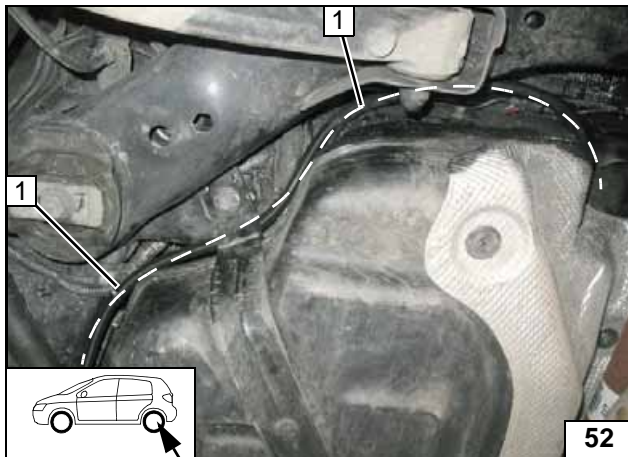

Route fuel line and metering pump wiring harness in corrugated tube 1 to the installation location of the metering pump.



Routing lines

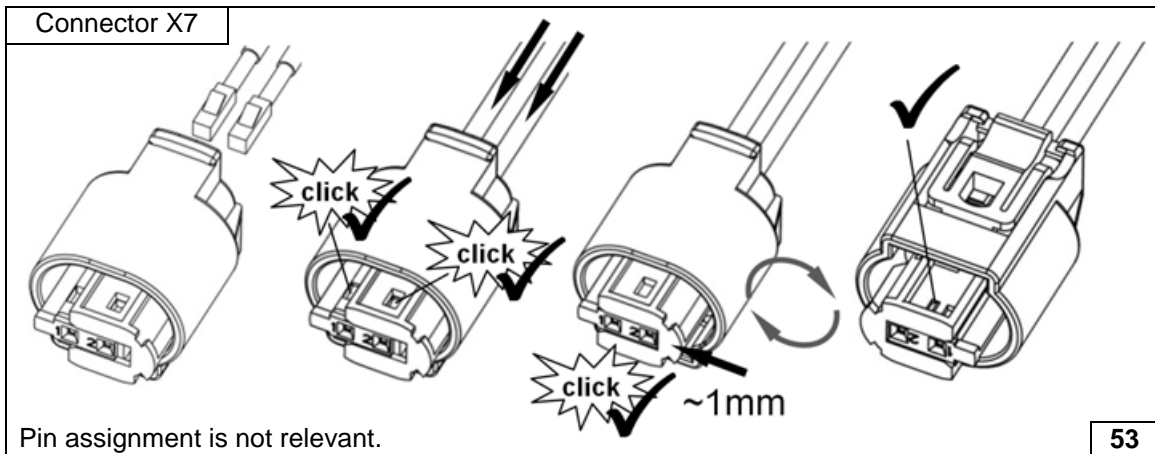

Completing metering pump connector

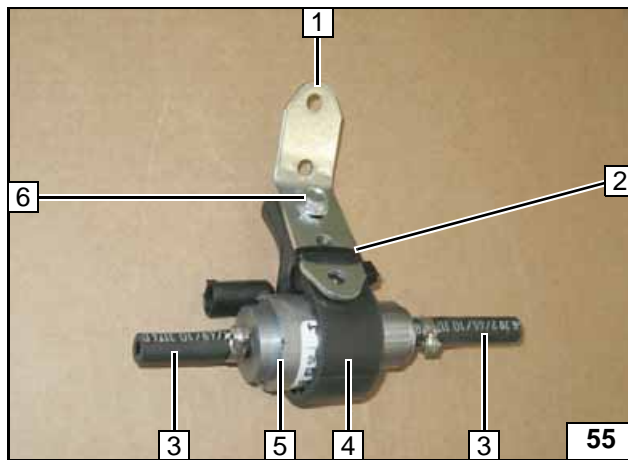
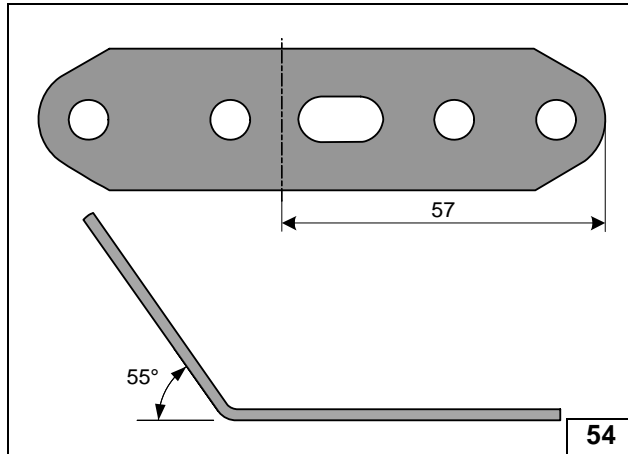
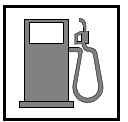

- 1 Perforated bracket
- 2 Cable tie
- 3 Hose section, 10mm dia. clamp [2x each]
- 4 Metering pump mount
- 5 Metering pump
- 6 M6x25 bolt, support angle bracket, flanged nut

Angling down perforated bracket

Premounting metering pump

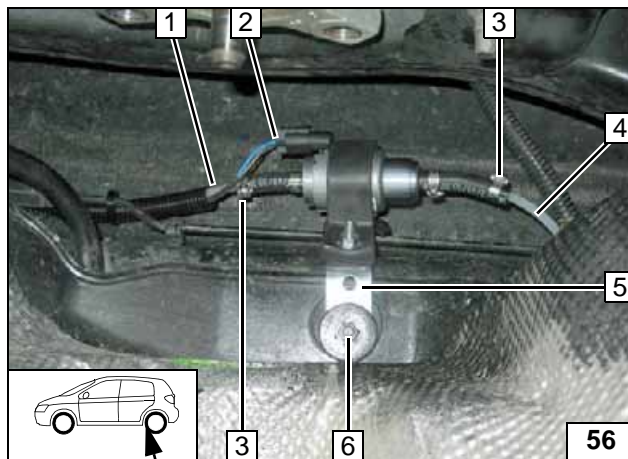

Check the position of the components; adjust if necessary. Check that they have freedom of movement.



- 1 Fuel line of heater
- 2 Wiring harness of metering pump, connector mounted
- 3 10 mm dia. clamp [2x]
- 4 Fuel line of fuel standpipe
- 5 Perforated bracket
- 6 Original vehicle bolt

Installing metering pump

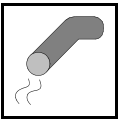

Exhaust Gas

a1 = 390
a2 = 350

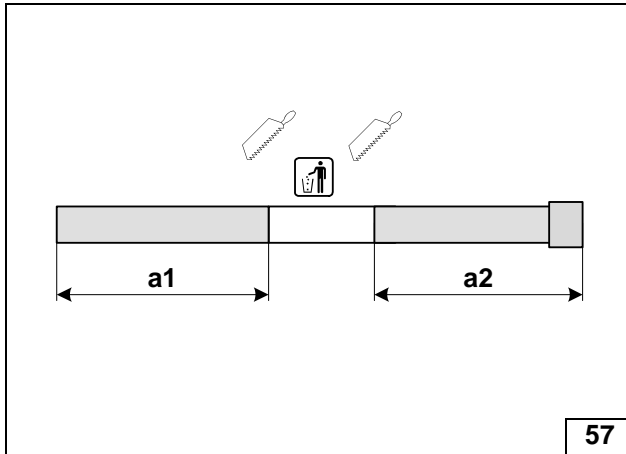

57

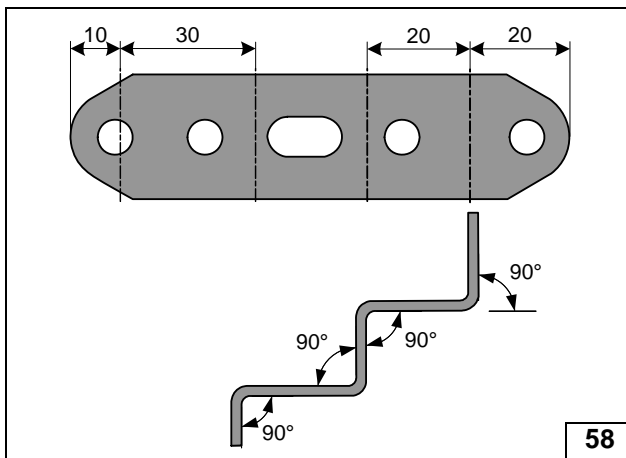

58

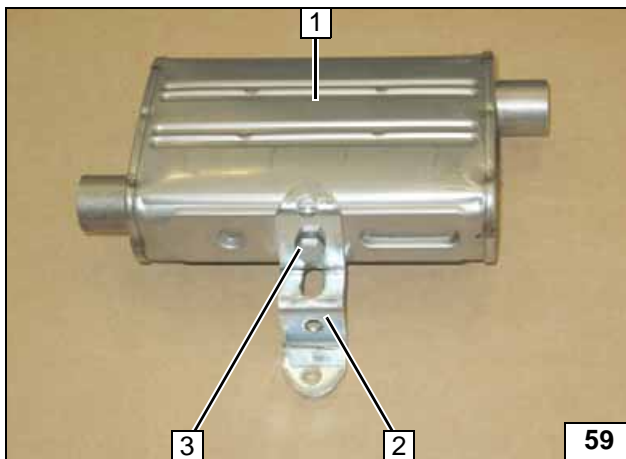

59

- 1 Silencer
- 2 Perforated bracket A
- 3 M6x16 bolt, spring lockwasher

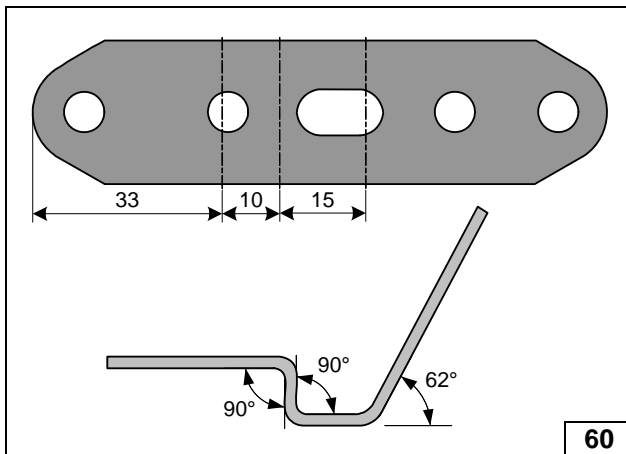

60

Preparing exhaust pipe

Angling down perforated bracket A

Premounting silencer

Angling down perforated bracket B

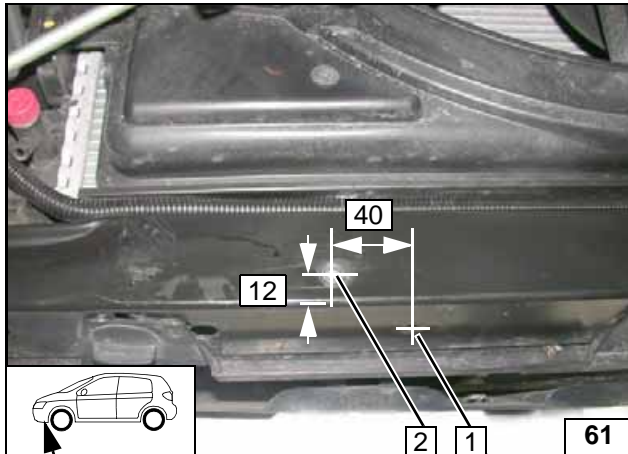
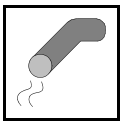

- 1 Original vehicle hole
- 2 9mm dia. hole for M6 rivet nut

**Cutting out
underride
protection**

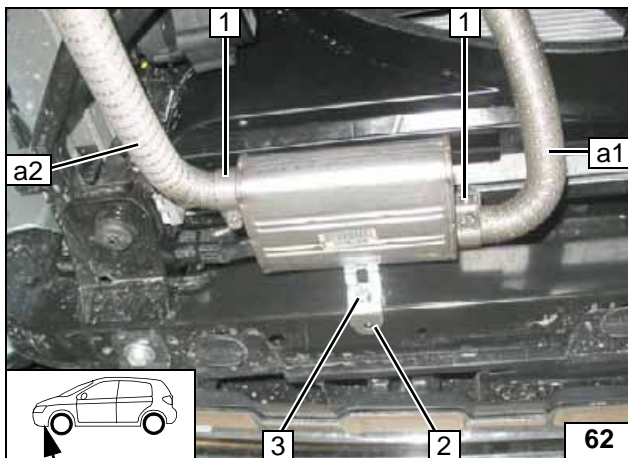

- 1 Hose clamp [2x]
- 2 Perforated bracket A
- 3 M6x20 bolt, spring lockwasher

**Installing
silencer**

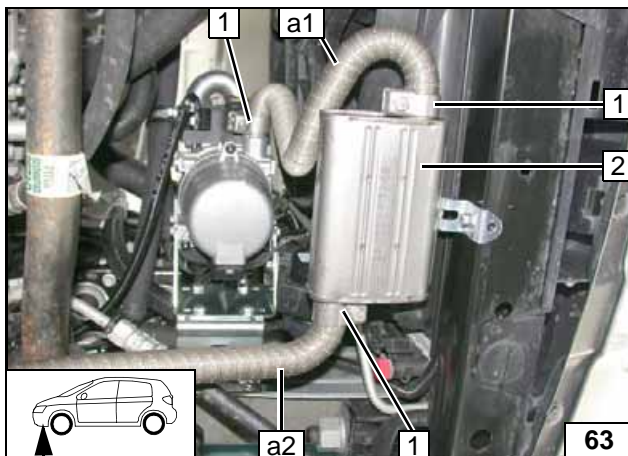

- 1 Hose clamp [3x]
- 2 Silencer

**Installing
exhaust
pipes a1
and a2**

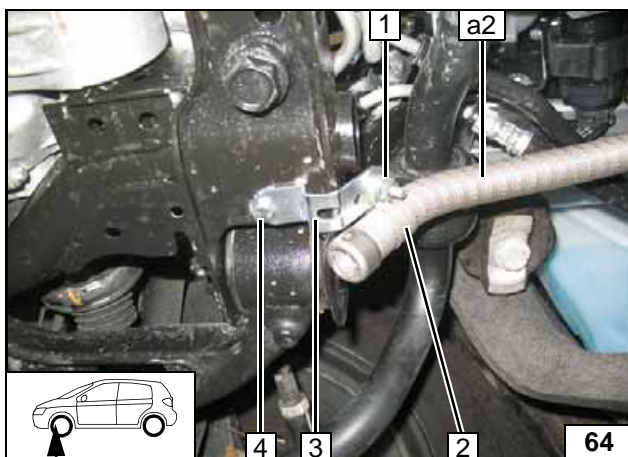

Ensure sufficient distance from neighbouring components.

- 1 M6x20 bolt, flanged nut
- 2 P-clamp
- 3 Perforated bracket B
- 4 M6x20 bolt, large diameter washer, flanged nut, existing hole

**Installing
exhaust
pipe a2**

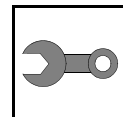

Final Work



Reassemble the components in reverse order. Check all hoses, clamps and all electrical connections for firm seating. Insulate and tie back loose lines. Only use manufacturer-approved coolant. Spray the heater components with anti-corrosion wax (Tectyl 100K).

- Connect the battery.
- Fill and bleed the coolant circuit according to the vehicle manufacturer's instructions.
- Program MultiControl CAR, teach Telearstart transmitter.
- For initial startup and function check, please see installation instructions.
- For the settings of the A/C control panel see the installation documentation in the additional kit 'Webasto Comfort' A/C control section 'Final Work'
- Place the 'Switch off parking heater before refuelling' caution label near the filler neck.



1 Underride protection

X =

Cutting out underride protection

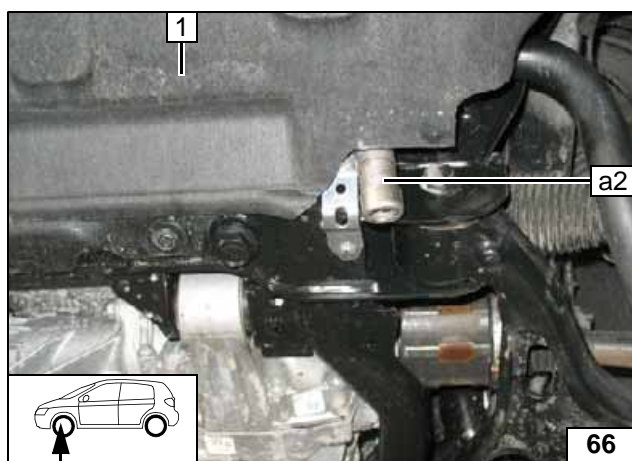

Ensure sufficient distance from neighbouring components.

1 Underride protection, installed

Aligning exhaust pipe a2



Webasto Thermo & Comfort SE
Postfach 1410
82199 Gilching
Germany
Internet: www.webasto.com
Technical Extranet:
<http://dealers.webasto.com>



Fuel Tank Sending Unit Template

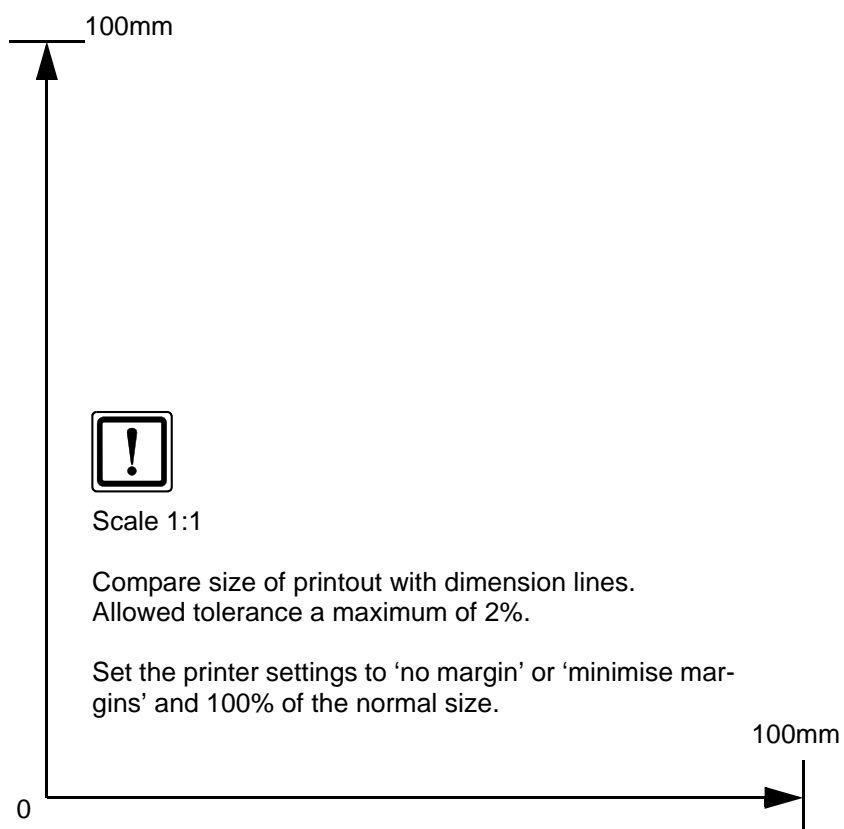
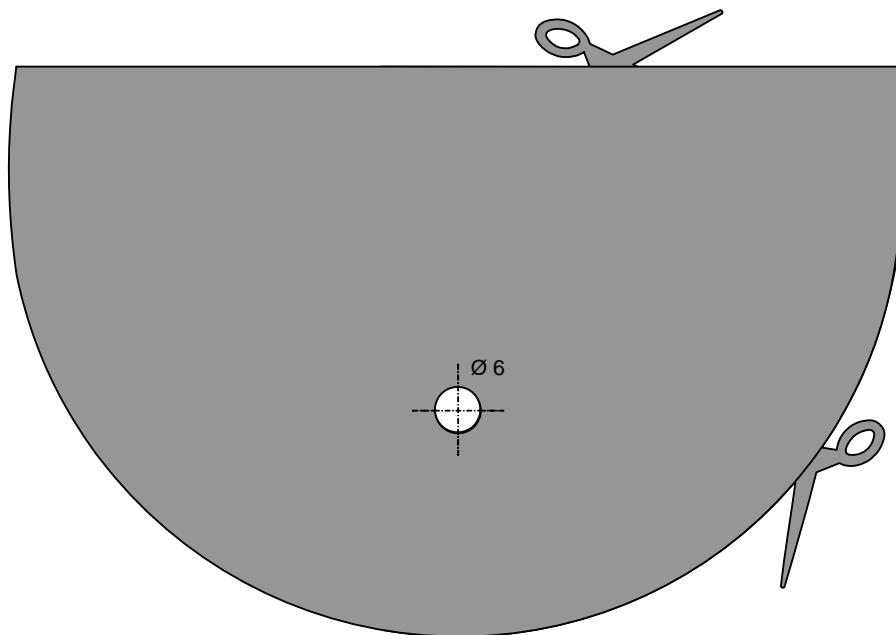

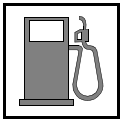

Fuel Standpipe Template

