



Water Heater

Thermo Top Evo Parking Heater



Installation Documentation Toyota Yaris

Validity

Manufacturer	Model	Type	Model year	EG BE No. / ABE
Toyota	Yaris	XP13M	From model year 2016	e11 * 2007 / 46 * 0152 * ...

Motorisation	Fuel	Emission standard	Transmission type	Output in kW	Displacement in cm ³	Engine code
1.4 D	Diesel	Euro 6	6-speed SG	66	1364	1ND-TV

SG = manual transmission

Left-hand drive vehicle

Verified equipment variants: Manual air-conditioning
Automatic air-conditioning
Front fog lights
LED daytime running lights

Not verified: Passenger compartment monitoring
Headlight washer system

Total installation time: approx. 8.5 hours

Toyota Yaris

Table of Contents

Validity	1	Preparing Installation Location	14
Necessary Components	2	Preparing Heater	16
Installation Instructions	2	Installing Heater	17
Information on Total Installation Time	2	Combustion Air	19
Information on Operating and Installation Instructions	3	Fuel	20
Information on Validity	4	Installing FuelFix	22
Technical Information	4	Coolant Circuit	25
Explanatory Notes on Document	4	Exhaust Gas	31
Preliminary Work	5	Final Work	33
Heater Installation Location	5	FuelFix Template	34
Preparing Electrical System	6	Operating Instructions for Manual Air-Conditioning	35
Electrical System, All Vehicles	8	Operating Instructions for Automatic Air-Conditioning	36
Fan Controller	9		
System Wiring Diagram for Manual Air-Conditioning	10		
System Wiring Diagram for Automatic A/C	11		
Cold Start System Installation	12		
Heater Control Installation	12		
MultiControl CAR Option	12		
Remote Option (Telestart)	12		

Necessary Components

Description	Order No.:
Basic delivery scope of Thermo Top Evo	In accordance with price list
Installation kit for Toyota Yaris 2016 Diesel	1325435A
In case of Telestart, heater control, as well as indicator lamp in consultation with end customer	In accordance with price list
In case of MultiControl CAR installation - timer cable extension	1319724_

Webasto Individual Option

Description	Order No.:
Webasto Individual Auxiliary Heating additional kit	1320077_
Webasto Individual Quick additional kit	9030826_
Webasto Individual Select additional kit	9030828_

Installation Instructions

Arrange for the vehicle to be delivered with the tank only about ¼ full.

The installation location of the push button in case of Telestart or ThermoCall should be confirmed with the end customer.

Depending on the space required and the vehicle manufacturer's instructions, we recommend the use of a vehicle battery with a higher electrical capacity.

Information on Total Installation Time

The total installation time includes the time needed for mounting and demounting the vehicle-specific components, the heater specific installation time and all other times required for the system integration and initial start-up of the heater. The total installation time may vary for vehicle equipment other than provided.

Information on Operating and Installation Instructions

1 Important information (not complete)

1.1 Installation and repair



The improper installation or repair of Webasto heating and cooling systems can cause fire or the leakage of deadly carbon monoxide, leading to serious injury or death.



To install and repair Webasto heating and cooling systems you need to have completed a special company training course and have the appropriate technical documentation, special tools and special equipment.



Installation and repair may ONLY be carried out by persons trained and certified in a Webasto training course. NEVER try to install or repair Webasto heating or cooling systems if you have not completed a Webasto training course, you do not have the necessary technical skills and you do not have the technical documentation, tools and equipment available to ensure that you can complete the installation and repair work properly.

Only use genuine Webasto parts. See the Webasto air and water heaters accessories catalogue for this purpose.

1.2 Operation

To ensure safe operation, we recommend having the heater checked every two years by an authorised Webasto dealer, especially when used over a long period and/or under extreme environmental conditions.

Do not operate the heater in closed rooms due to the danger of poisoning and suffocation.

Always switch off the heater before refuelling.

The heater may only be used with the prescribed fuel diesel (DIN EN 590) or petrol (DIN EN 228).

The heater may not be cleaned with a high-pressure cleaner.

1.3 Please note

ALWAYS follow all Webasto installation and operating instructions and observe all warnings.

To become familiar with and understand all functions and properties of the heater, the operating instructions must be read carefully and observed at all times.

For proper, safe installation and repair work, the installation instructions with all warnings and safety information must be carefully read and observed at all times. Please always contact a workshop authorised by Webasto for all installation and repair work.

Important

Webasto shall assume no liability for defects, damage and injuries resulting from a failure to observe the installation, repair and operating instructions of the information contained in them.

This liability exclusion particularly applies to improper installations and repairs, installations and repairs by untrained persons or in the case of a failure to use genuine spare parts.

The liability due to culpable disregard to life, limb or health and due to damage or injuries caused by a wilful or reckless breach of duty remain unaffected, as does the obligatory product liability.

Installation should be carried out according to the general, standard rules of technology. Unless specified otherwise, fasten hoses, lines and wiring harnesses to original vehicle lines and wiring harnesses using cable ties. Insulate loose wire ends and tie back. Connectors on electronic components have to audibly click into place during installation.

Sharp edges should be fitted with rub protection. Spray unfinished body areas, e.g. drilled holes, with anti-corrosion wax (Tectyl 100K).

Observe the instructions and guidelines of the respective vehicle manufacturer for demounting and mounting vehicle specific components!

The initial startup is to be executed with the Webasto Thermo Test Diagnosis.

When installing a programmable control module (e.g. a PWM Gateway), the corresponding settings must be checked or adjusted.

2 Statutory regulations governing installation

Guidelines	Thermo Top Evo
Heating Directive ECE R122	E1 00 0258
EMC Directive ECE R10	E1 04 5627

Note

The regulations of these guidelines are binding in the scope of the Directive 70/156/EEC and/or 2007/46/EC (for new vehicle models from 29/04/2009) and should also be observed in countries in which there are no special regulations.

Important

Failure to follow the installation instructions will result in the invalidation of the type approval for the heater and therefore invalidation of the general **homologation of the vehicle**.

Note

The heater is licensed in accordance with paragraph 19, section 3, No. 2b of the StVZO (German Road Traffic Licensing Authority).

2.1 Excerpt from ECE regulation 122 (heating system) paragraph 5 for the installation of the heater

Beginning of excerpt.

ANNEX VII

REQUIREMENTS FOR COMBUSTION HEATERS AND THEIR INSTALLATION

1. GENERAL REQUIREMENTS

1.7.1. A clearly visible tell-tale in the operator's field of view shall inform when the combustion heater is switched on or off.

2. VEHICLE INSTALLATION REQUIREMENTS

2.1. Scope

2.1.1. Subject to paragraph 2.1.2, combustion heaters shall be installed according to the requirements of this Annex.

2.1.2. Vehicles of category O having liquid fuel heaters are deemed to comply with the requirements of this Annex.

2.2. Positioning of heater

2.2.1. Body sections and any other components in the vicinity of the heater must be protected from excessive heat and the possibility of fuel or oil contamination.

2.2.2. The combustion heater shall not constitute a risk of fire, even in the case of overheating. This requirement shall be deemed to be fulfilled if the installation ensures an adequate distance to all parts and suitable ventilation, by the use of fire resistant materials or by the use of heat shields.

2.2.3. In the case of M2 and M3 vehicles, the heater must not be positioned in the passenger compartment. However, an installation in an effectively sealed envelope which also complies with the conditions in paragraph 2.2.2 may be used.

2.2.4. The label referred to in paragraph 1.4 or a duplicate, must be positioned so that it can be easily read when the heater is installed in the vehicle.

2.2.5. Every reasonable precaution should be taken in positioning the heater to minimise the risk of injury and damage to personal property.

2.3. Fuel supply

2.3.1. The fuel filler must not be situated in the passenger compartment and must be provided with an effective cap to prevent fuel spillage.

2.3.2. In the case of liquid fuel heaters, where a supply separate to that of the vehicle is provided, the type of fuel and its filler point must be clearly labelled.

2.3.3. A notice, indicating that the heater must be shut down before refuelling, must be affixed to the fuelling point. In addition a suitable instruction must be included in the manufacturer's operating manual.

2.4. Exhaust system

2.4.1. The exhaust outlet must be located so as to prevent emissions from entering the vehicle through ventilators, heated air inlets or opening windows.

2.5. Combustion air inlet

2.5.1. The air for the combustion chamber of the heater must not be drawn from the passenger compartment of the vehicle.

2.5.2. The air inlet must be so positioned or guarded that blocking by rubbish or luggage is unlikely.

2.6. Heating air inlet

2.6.1. The heating air supply may be fresh or recirculated air and must be drawn from a clean area not likely to be contaminated by exhaust fumes emitted either by the propulsion engine, the combustion heater or any other vehicle source.

2.6.2. The inlet duct must be protected by mesh or other suitable means.

2.7. Heating air outlet

2.7.1. Any ducting used to route the hot air through the vehicle must be so positioned or protected that no injury or damage could be caused if it were to be touched.

2.7.2. The air outlet must be so positioned or guarded that blocking by rubbish or luggage is unlikely.

End of excerpt.

In multilingual versions the German language is binding.

Toyota Yaris

Information on Validity

This installation documentation applies to Toyota Yaris Diesel vehicles - for validity, see page 1 - from model year 2016 and later, assuming technical modifications to the vehicle do not affect installation, any liability claims excluded. Depending on the vehicle version and equipment, modifications may be necessary during installation with respect to this 'installation documentation'.

Vehicle and engine types, equipment variants and other specifications not listed in this installation documentation have not been tested. However, installation according to this installation documentation may be possible.

Technical Information

Special Tools

- Hose clamp pliers for auto-tightening hose clamps
- Hose clamp pliers for Clic hose clamps of type W
- Automatic wire stripper, 0.2 - 6mm²
- Crimping pliers for cable lug / tab connector, 0.5 - 6mm²
- Torque wrench for 2.0 - 10 Nm
- Hose clamping pliers
- Metric thread-setter kit
- Deep-hole marker
- Webasto Thermo Test Diagnosis with current software

Dimensions

- All dimensions are in mm.

Tightening torque values

- Tightening torque values of 5x13 heater bolts and 5x11 heater stud bolts = 8Nm.
- Tightening torque value of 5x15 water connection piece retaining plate bolt = 7Nm.
- Tighten other bolt connections in accordance with manufacturer's instructions or in accordance with state-of-the-art technology.

Explanatory Notes on Document

You will find an identification mark on the outside top right corner of the page in question to provide you with a quick overview of the individual working steps.

Mechanics



Electrics



Coolant Circuit



Combustion Air

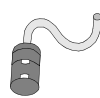

Fuel



Exhaust Gas



Software



Special features are highlighted using the following symbols:

Specific risk of damage to components.



Specific risk due to electrical voltage.



Specific risk of fire or explosion.



Reference to a special technical feature.



The arrow in the vehicle icon indicates the position on the vehicle and the viewing angle.

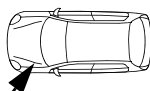

Reference to the manufacturer's vehicle-specific documents.



Reference to specific installation instructions of Webasto components (demonstrated with the example of the FuelFix).



Reference to general installation instructions of Webasto components.



Tightening torque according to the manufacturer's vehicle-specific documents.



Toyota Yaris

Preliminary Work

Vehicle



- Open the fuel tank cap.
- Ventilate the fuel tank.
- Close the fuel tank cap again.
- Depressurise the cooling system.
- Disconnect and completely remove the battery together with the carrier.
- Remove the air filter completely, together with the intake hose.
- Remove the windscreen wipers.
- Remove the coolant reservoir cap.
- Remove the windscreen wiper motor.
- Remove the entire coolant reservoir.
- Remove the left headlight.
- Detach the wheel well trim on the right and left.
- Remove the bumper.
- Remove the front left-hand underride protection.
- Remove the rear bench seat.
- Open the tank-fitting service lid on the right.
- Remove the lower instrument panel trim on the driver's side
- Remove the footwell trim on the driver's side.



Heater

- Remove years that do not apply from the type and duplicate label.
- Attach the duplicate label (type label) visibly in the appropriate place in the engine compartment.

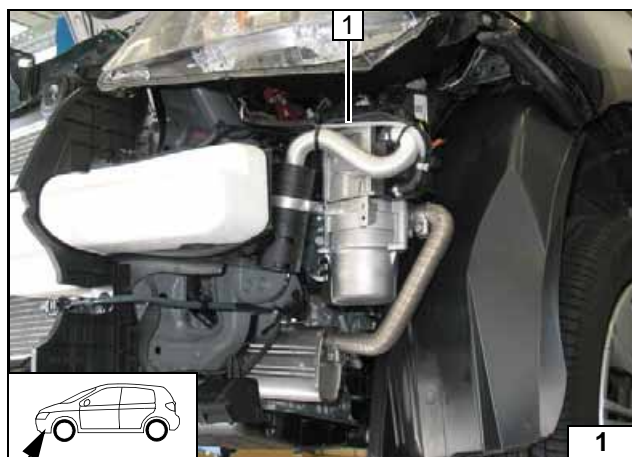

Heater Installation Location

- 1 Heater

Installation location

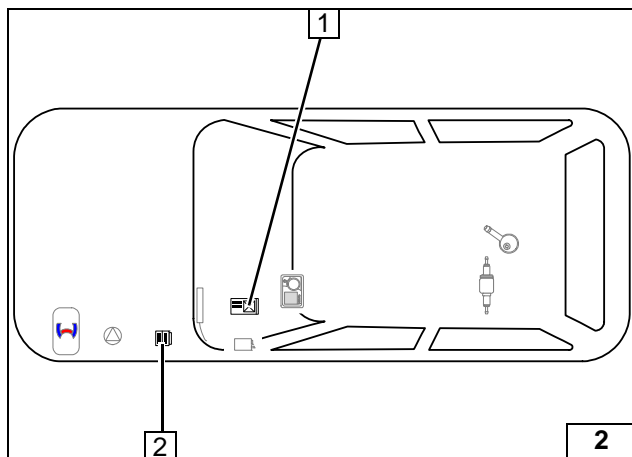

Preparing Electrical System

- 1 Passenger compartment relay and fuse holder
- 2 Engine compartment fuse holder



Installation overview

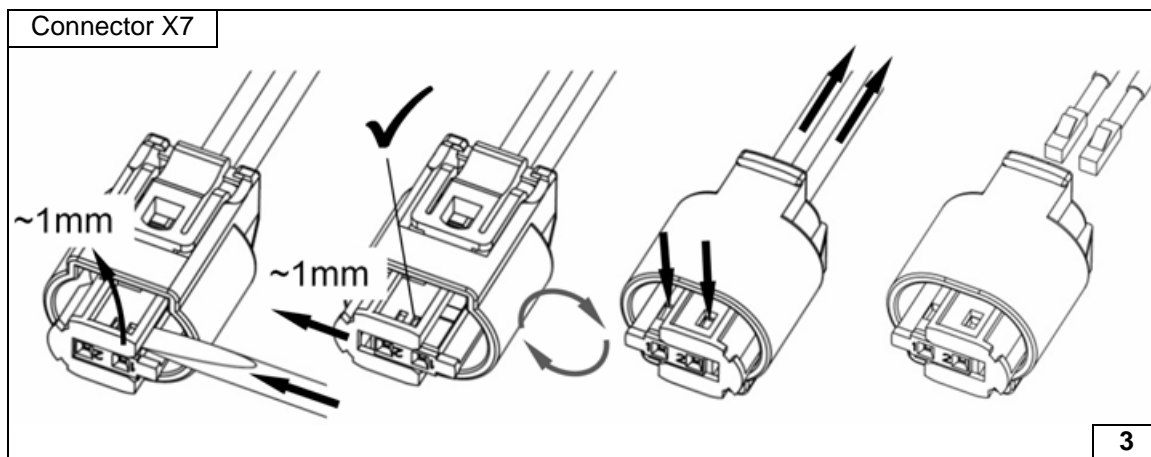

Dismantling metering pump connector

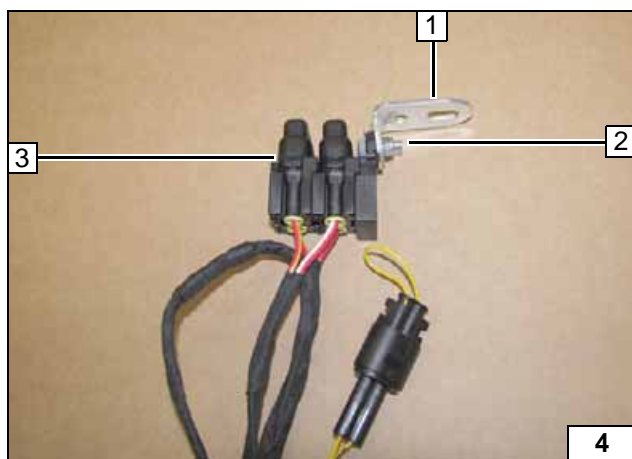

- 1 Angle bracket
- 2 M5x16 bolt, large diameter washer [2x], retaining plate for engine compartment fuse holder, nut
- 3 Fuse F1-2

Preparing fuse holder of engine compartment

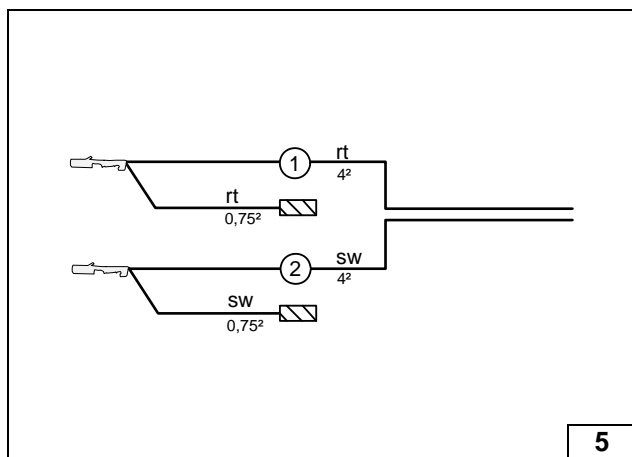

Wire sections retain their numbering in the entire document.

- ① Red (rt) wire of fan wiring harness
- ② Black (sw) wire of fan wiring harness



Assigning wires

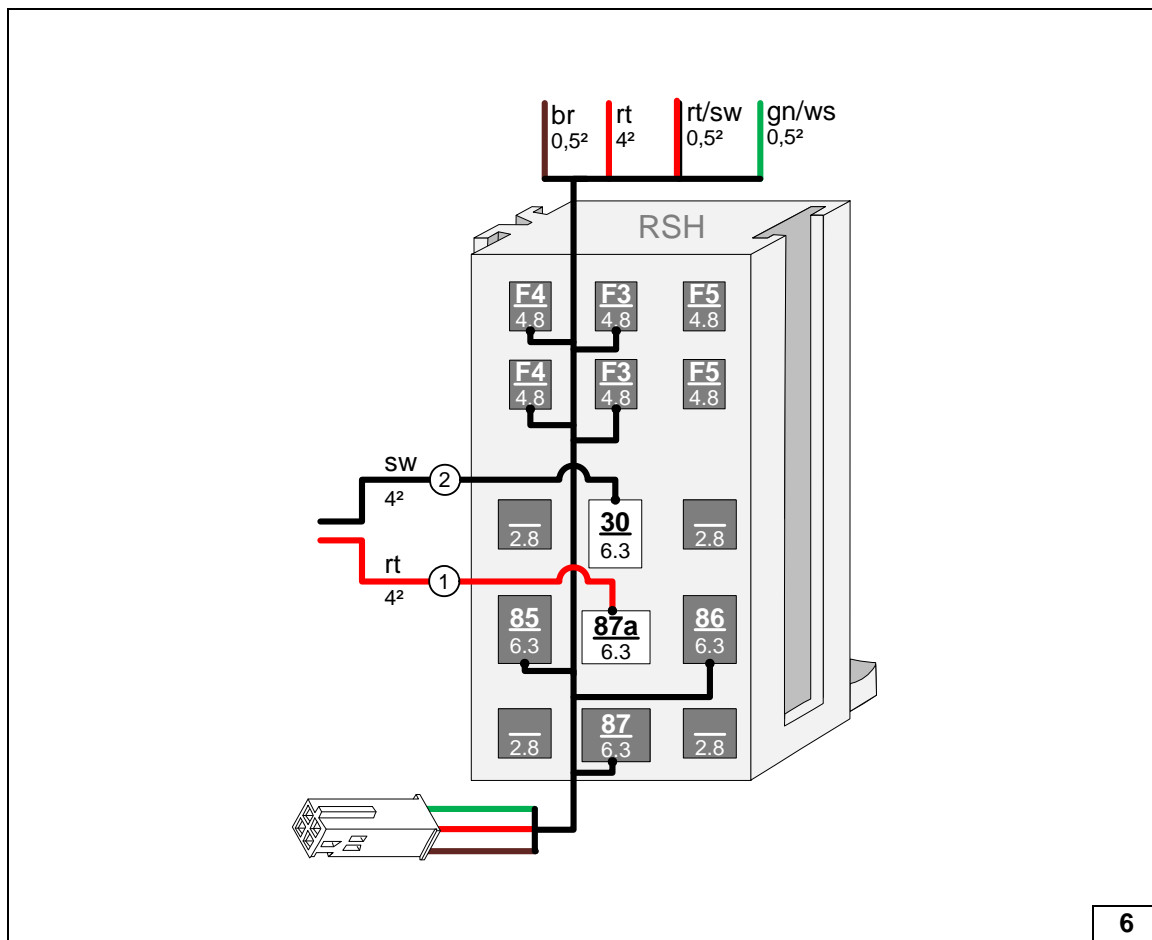

Connecting wires to passenger compartment relay and fuse holder

6

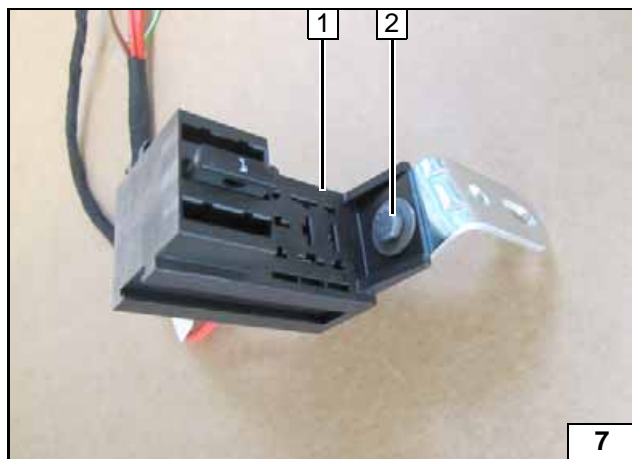

- 1 Passenger compartment relay and fuse holder
- 2 M5x16 bolt, large diameter washer [2x], angle bracket, nut

Preparing passenger compartment relay and fuse holder

7

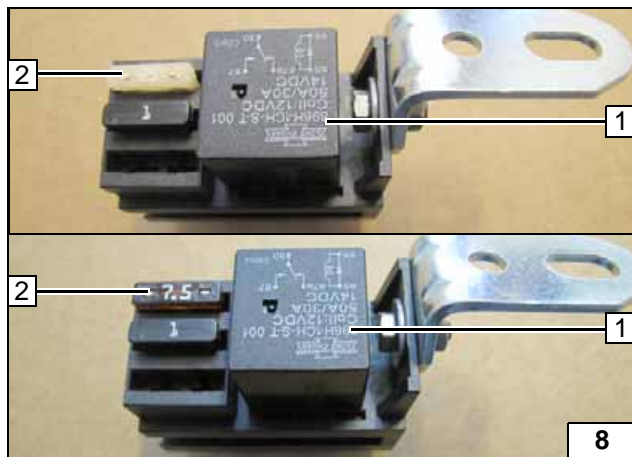

Manual air-conditioning

- 1 Relay K1
- 2 25A fuse F4

Automatic air-conditioning

- 1 Relay K1
- 2 7.5A fuse F4

Inserting fuse F4 and relay K1

8



Electrical System, All Vehicles



Positive wire

- 1 Positive wire on positive battery terminal

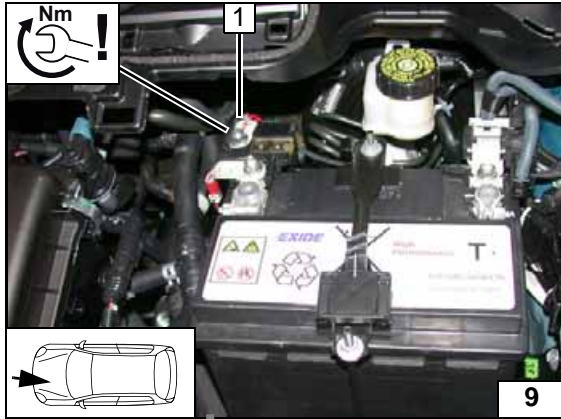

Wiring harness pass through

- 1 Protective rubber plug

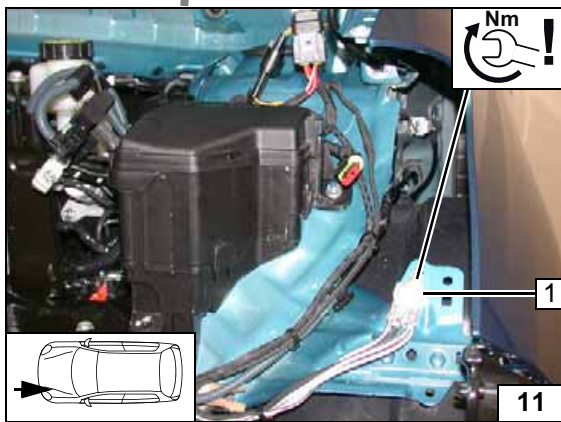
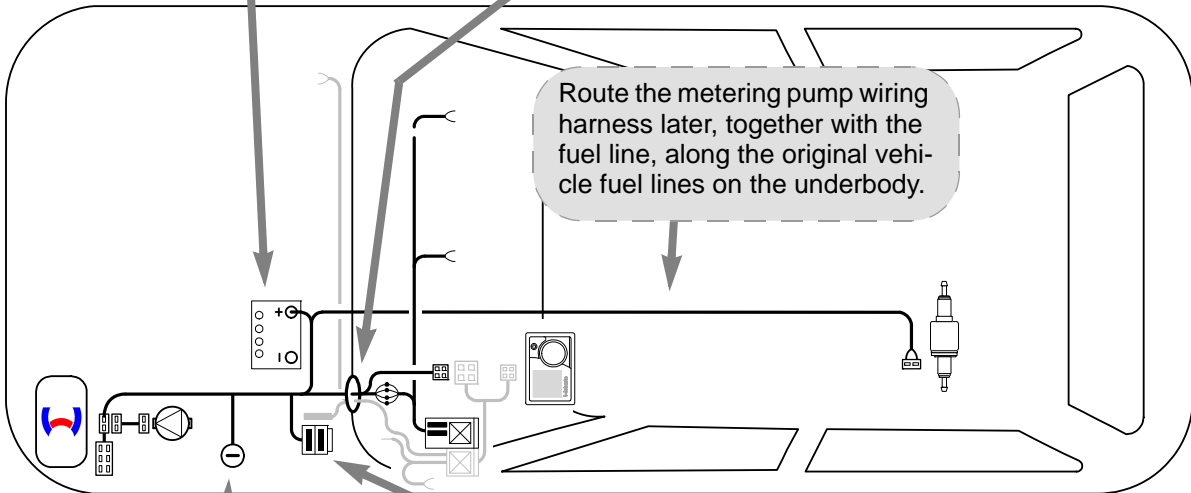
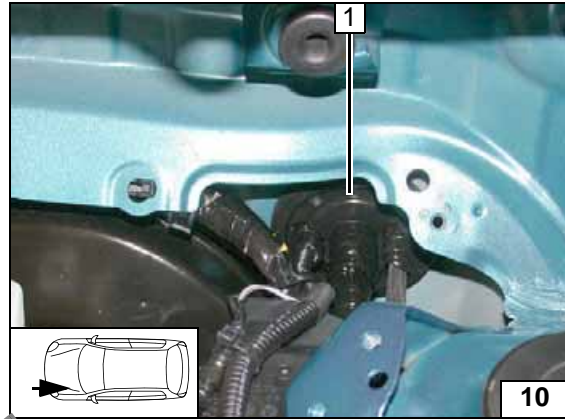

Earth wire

- 1 Earth wire on original vehicle earth support point

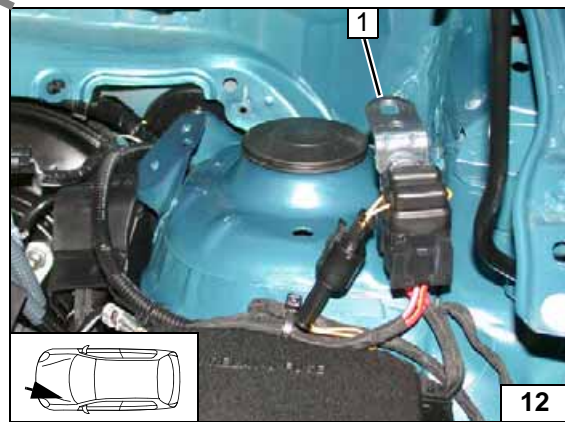

Engine compartment fuse holder

Position fuse holder of engine compartment 1 as shown. Will be mounted during final work.



Wiring harness routing diagram



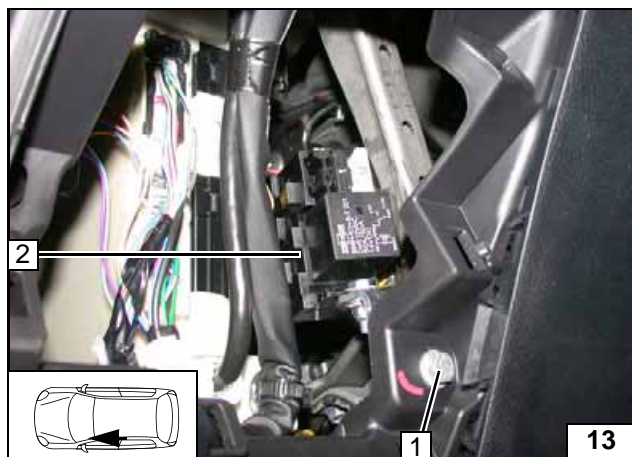

Fan Controller

Produce all following electrical connections as shown in the system wiring diagram.

Remove original vehicle bolt at position 1 and discard.

- 1 M6x25 bolt, 8 mm shim, angle bracket, flanged nut
- 2 Passenger compartment relay and fuse holder

Installing relay and fuse holder of passenger compartment

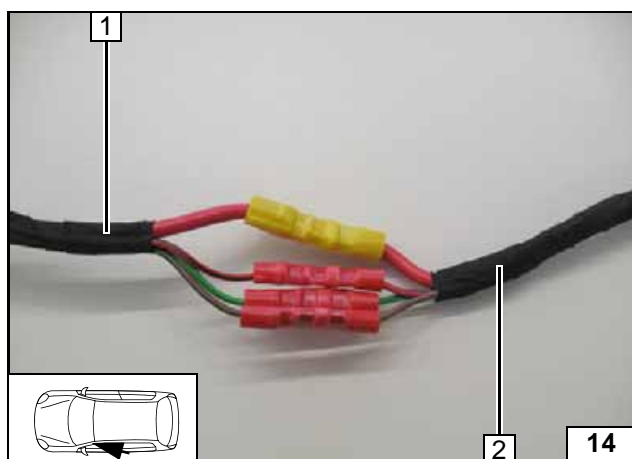

- 1 Passenger compartment relay and fuse holder wiring harness
- 2 Heater wiring harness

Connecting same colour wires of wiring harnesses

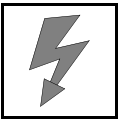

System Wiring Diagram for Manual Air-Conditioning

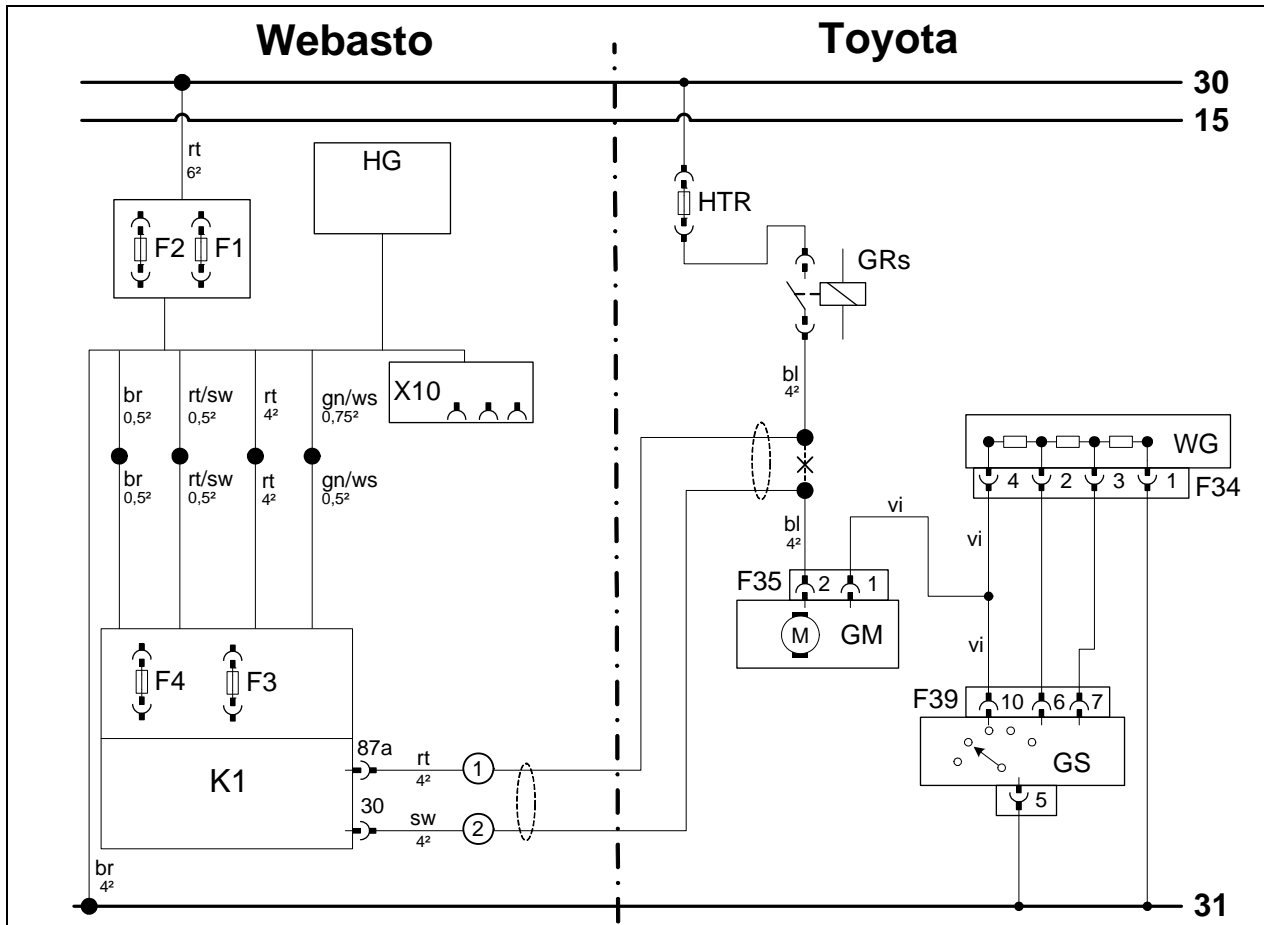

System wiring diagram

Webasto components		Vehicle components		Colours and symbols	
HG	TT-Evo heater	HTR	40A fuse	rt	red
F1	20A fuse	GRs	Fan relay	sw	black
F2	30A fuse	WG	Resistor group	gn	green
X10	4-pin socket of heater control	F34	WG connector	vi	violet
A	Adapter connector of CLR	GM	Fan motor	ws	white
B	Adapter socket of CLR	GS	Fan switch	br	brown
F3	1A fuse	F39	GS connector	bl	blue
F4	25A fuse				
K1	Fan relay				
				X	Cutting point
				Wiring colours may vary.	

Legend

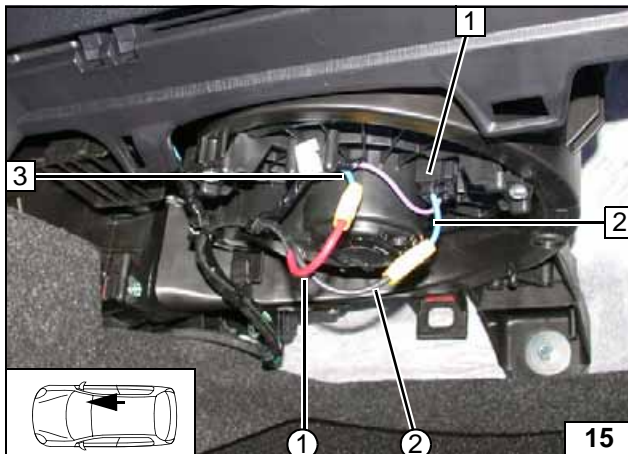

- 1 2-pin connector F35 of fan motor
- 2 Blue (bl) wire of connector F35/ pin 2
- 3 Blue (bl) wire of fan relay
- ① Red (rt) wire of K1/87a, fan wiring harness
- ② Black (sw) wire of K1/30, fan wiring harness



Connecting fan motor

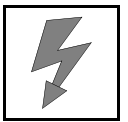

System Wiring Diagram for Automatic A/C

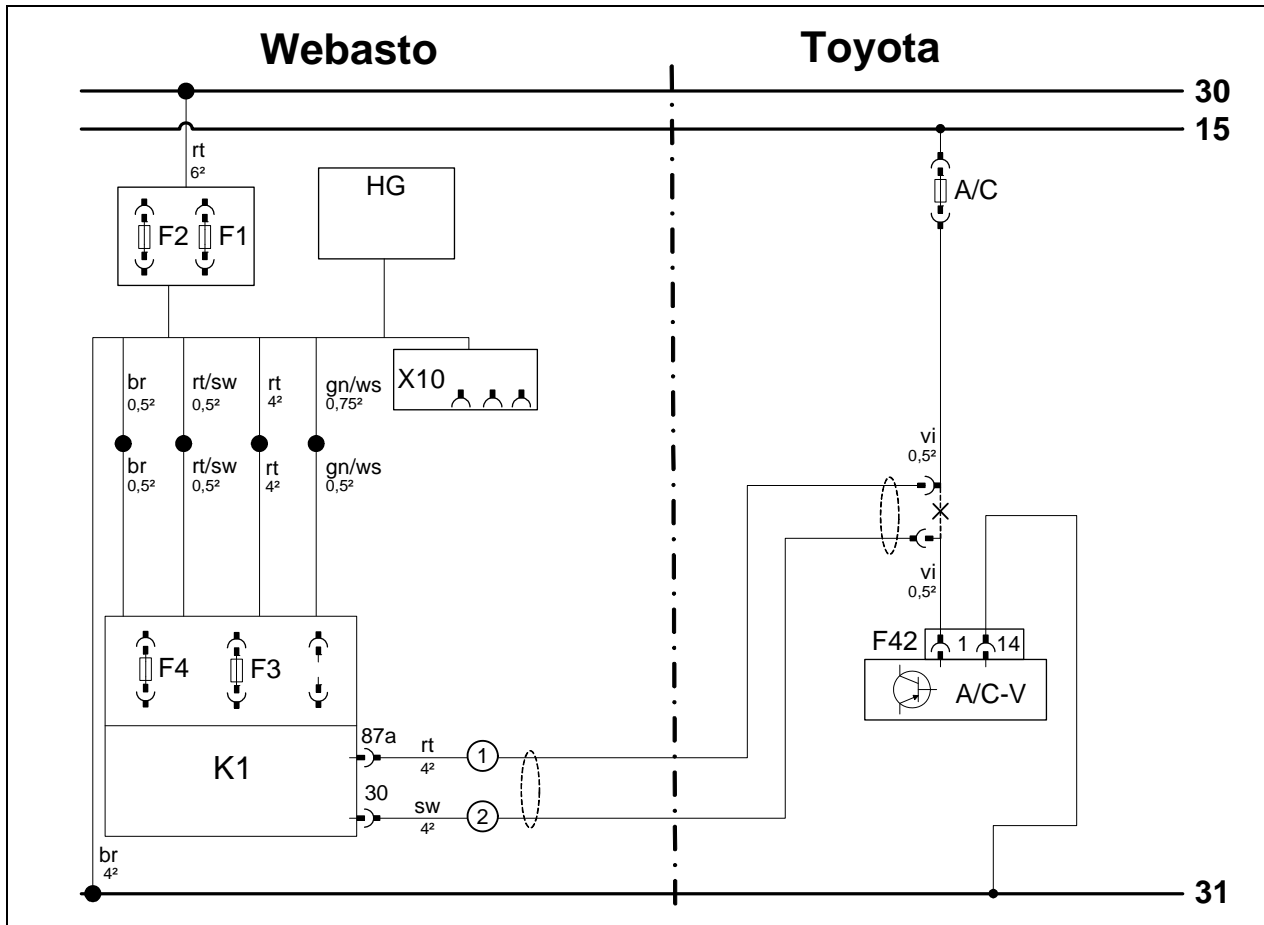

System wiring diagram

Webasto components		Vehicle components		Colours and symbols	
HG	TT-Evo heater	A/C	7.5A fuse	rt	red
F1	20A fuse	A/C-V	A/C booster	sw	black
F2	30A fuse	F42	40-pin connector of A/C V	gn	green
X10	4-pin socket of heater control			vi	violet
A	Adapter connector of CLR			ws	white
B	Adapter socket of CLR			br	brown
CLR	CLR Module				
F3	1A fuse				
F4	7.5A fuse			X	Cutting point
K1	Fan relay				Wiring colours may vary.

Legend

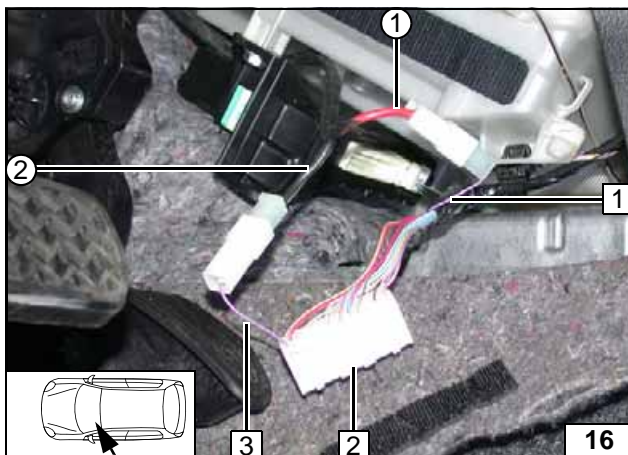

- 1 Violet (vi) wire of A/C fuse
- 2 40-pin connector F42 of A/C booster
- 3 Violet (vi) wire of connector F42 of A/C booster/ pin 1
- ① Red (rt) wire of K1/87a, fan wiring harness
- ② Black (sw) wire of K1/30, fan wiring harness

Connecting A/C booster

View of F42 connector on contact side:

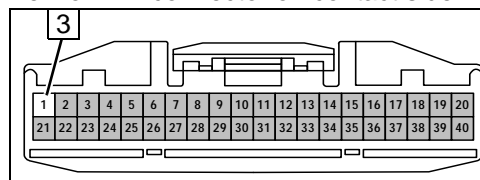



Cold Start System Installation

! Integrate the cold start system as explained in the separate installation documentation:

Cold start system installation documentation for Toyota Yaris diesel

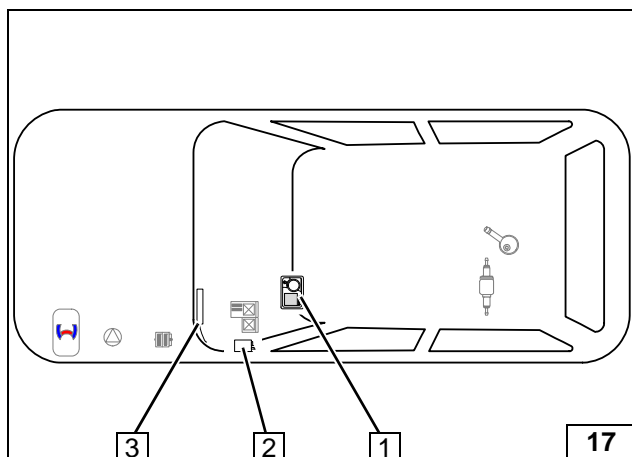

Heater Control Installation

- 1 MultiControl CAR
- 2 Telestart receiver
- 3 Telestart aerial



Installation overview

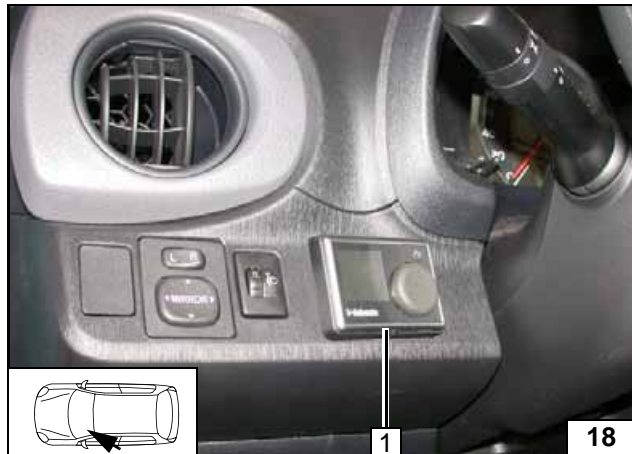

MultiControl CAR Option

- 1 MultiControl CAR installation frame



Installing MultiControl CAR

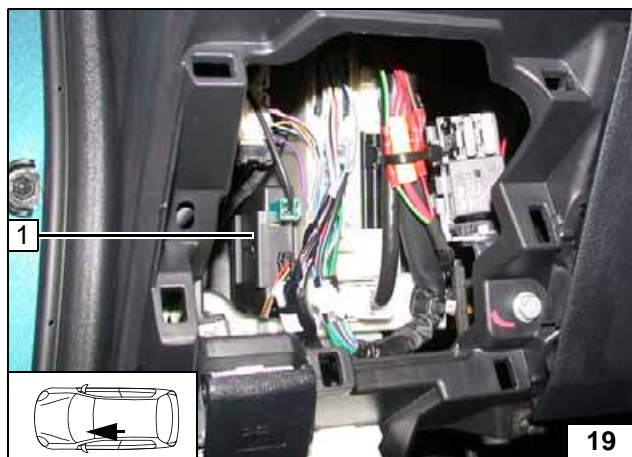

Remote Option (Telestart)

Fasten receiver 1 with double-sided adhesive tape.



Installing receiver

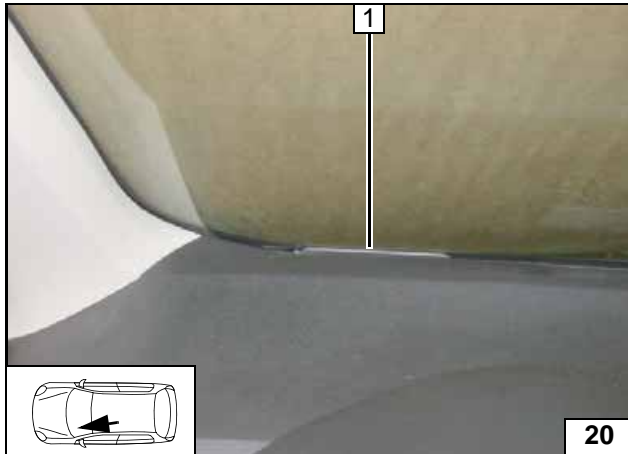
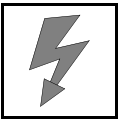

1 Aerial

Installing aerial

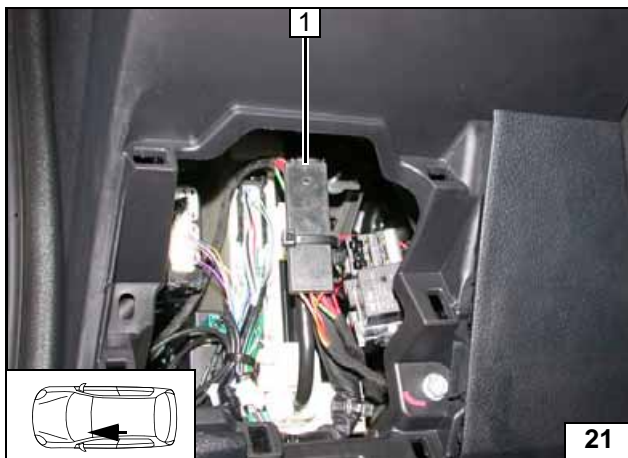

Temperature sensor T100 HTM

Fasten temperature sensor 1 with cable tie.



Installing temperature sensor

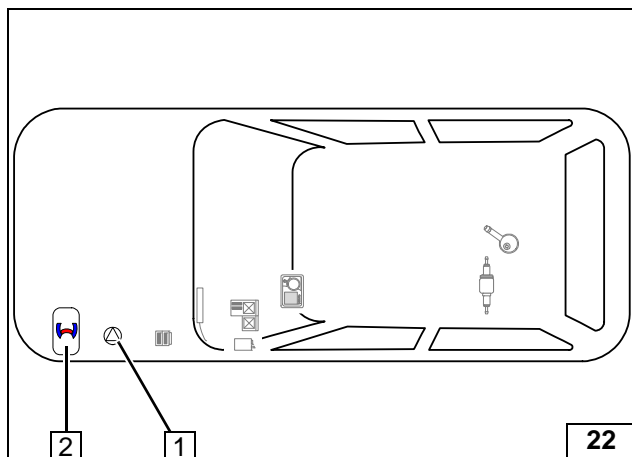

Preparing Installation Location

- 1 Circulating pump
- 2 Heater



Installation overview

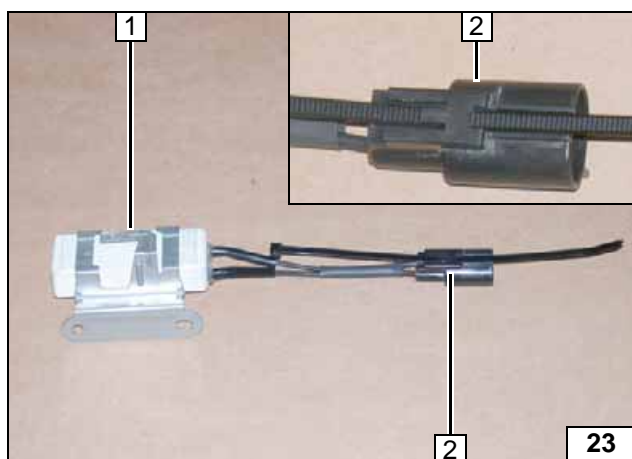

Resistor with bracket and connector 1 removed for better display.



- 2 Cable tie mounted on connector

Preparing resistor

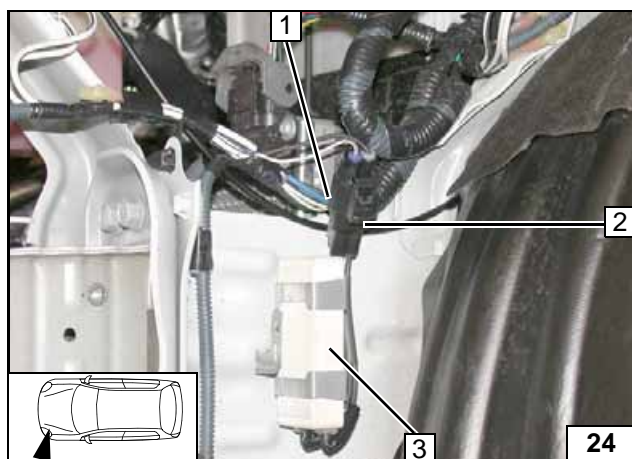

Fasten original vehicle connector 2 with cable tie to original vehicle wiring harness (close cable tie 1)



- 3 Resistor with bracket installed at the same position

Installing resistor

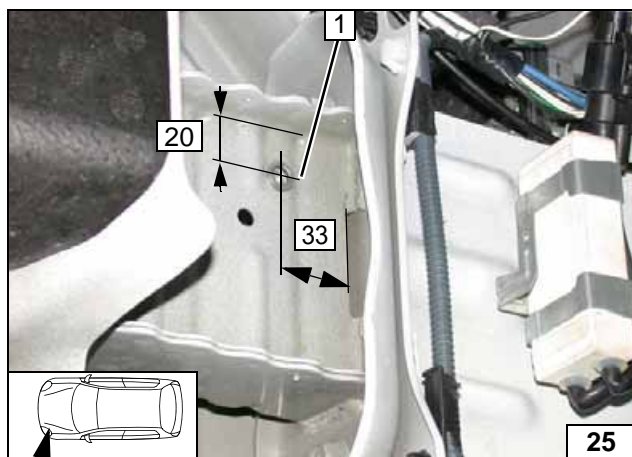

- 1 9.1 mm dia. hole; rivet nut

Installing rivet nut

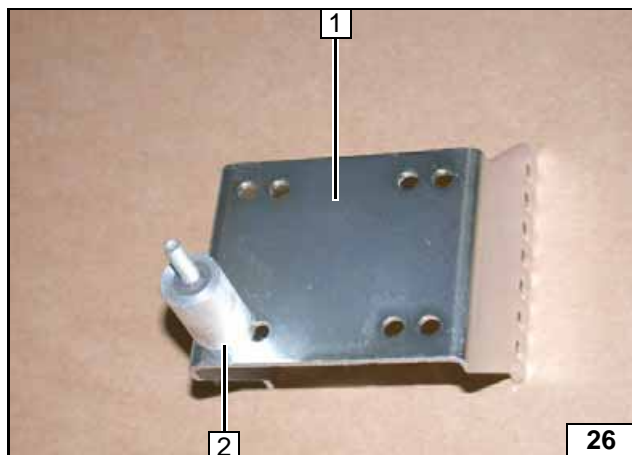
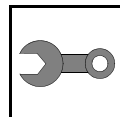

- 1 Bracket
- 2 M6x60 bolt, spring lockwasher, 5 mm shim, 30 mm shim, washer, lock washer

Preparing bracket

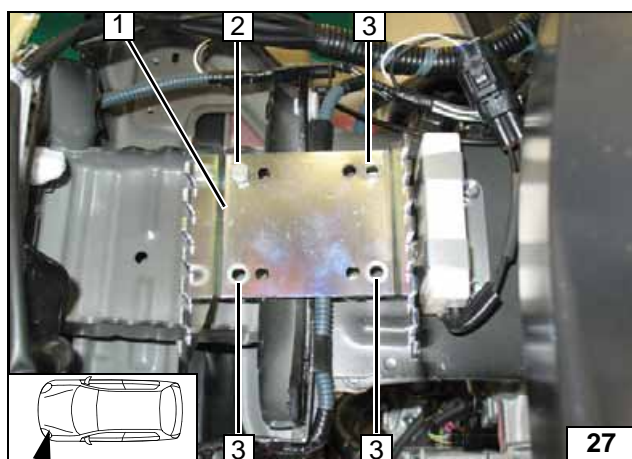

Align bracket 1 and mount loosely.



- 2 M6x60 bolt
- 3 Copy hole pattern [3x]

Copying hole pattern

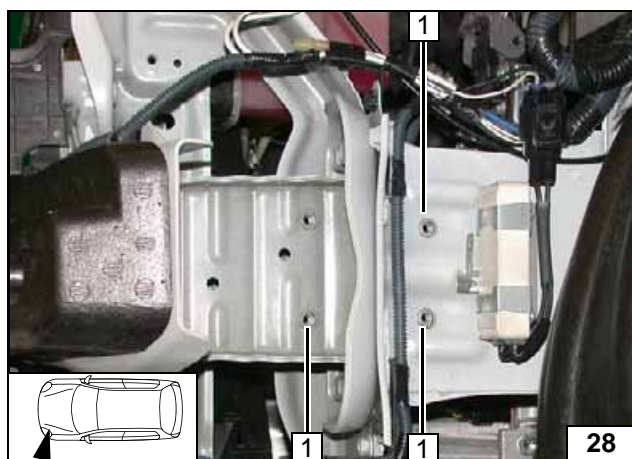

Remove bracket.



- 1 9.1 mm dia. hole; rivet nut [3x each]

Installing rivet nut

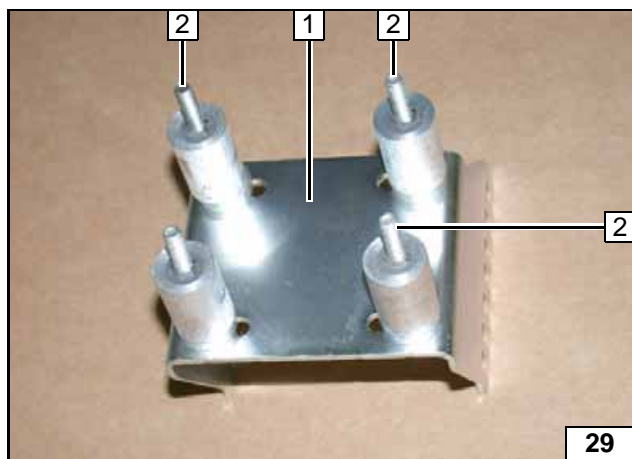

- 1 Bracket
- 2 M6x60 bolt, spring lockwasher, 5 mm shim, 30 mm shim, washer, lock washer [3x each]

Preparing bracket

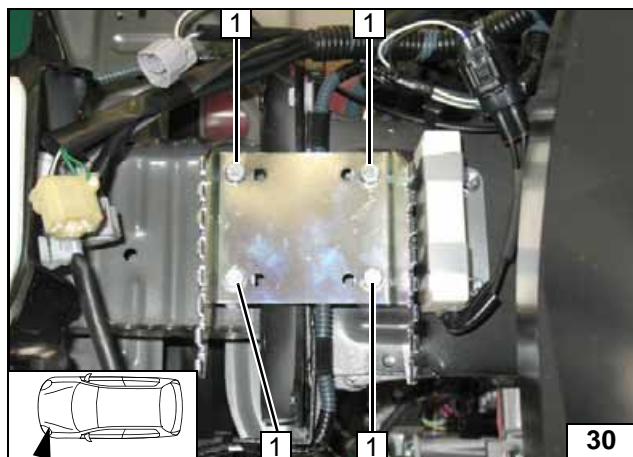
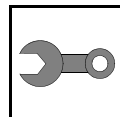

1 Tighten M6x60 bolt [4x]

Installing bracket

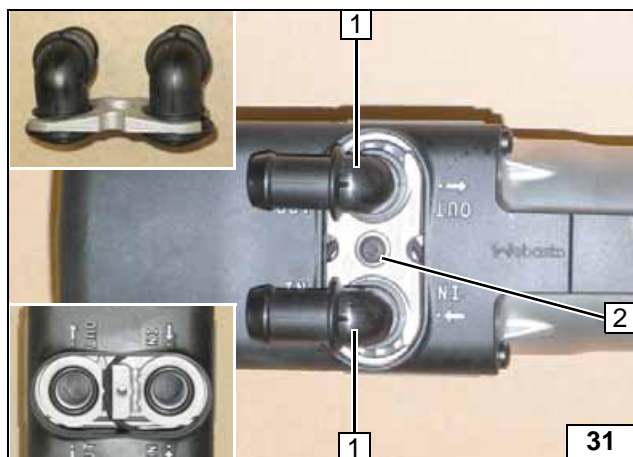

Preparing Heater

- 1 Water connection piece, sealing ring [2x each]
- 2 5x15 self-tapping bolt, retaining plate of water connection piece



Installing water connection piece

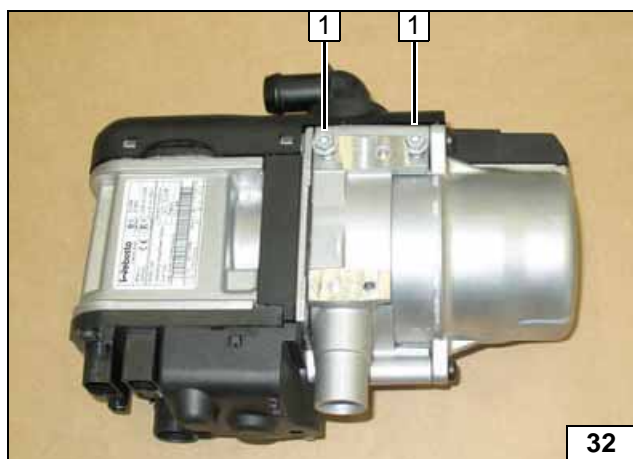

Screw 5x13 self-tapping bolts 1 [2x] into existing holes by a maximum of 3 thread turns.



Premounting bolts loosely

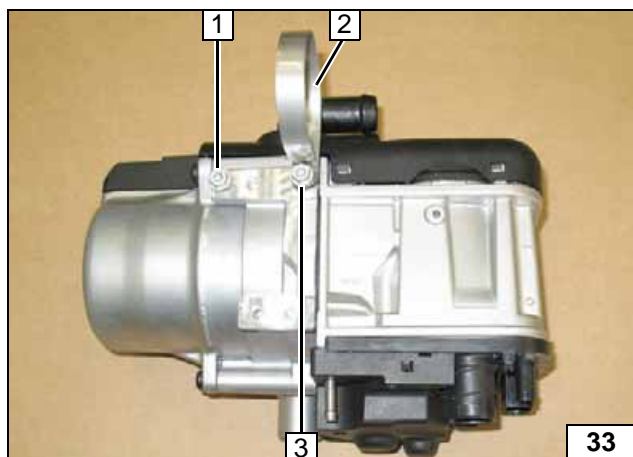

Screw 5x13 self-tapping bolts 1 [2x] into existing holes in position 1 and 3 by a maximum of 3 thread turns. Loosely mount 51 mm dia. clamp 2 at position 3.



Premounting bolts loosely

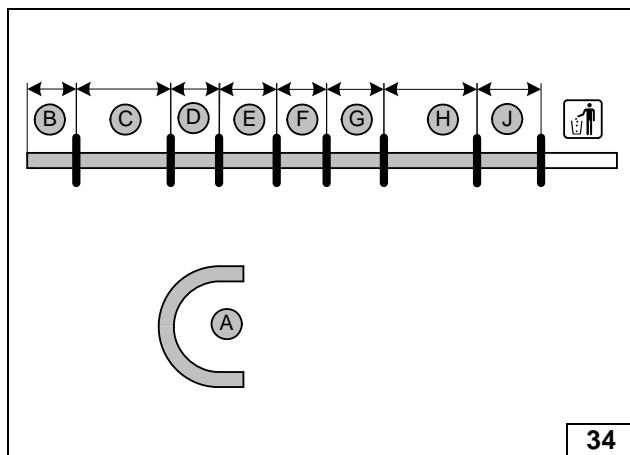
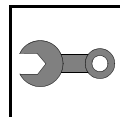

- A = 180°, 18mm dia.
- B = 160
- C = 360
- D = 60
- E = 130
- F = 80
- G = 160
- H = 360
- J = 160

Cutting hoses to length

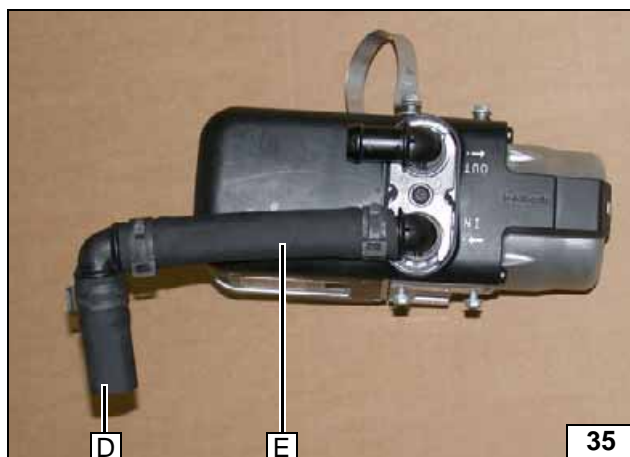

All spring clips = 25 mm dia.
All connecting pipes 90° and 18x18 mm dia.



Premounting hoses of heater inlet

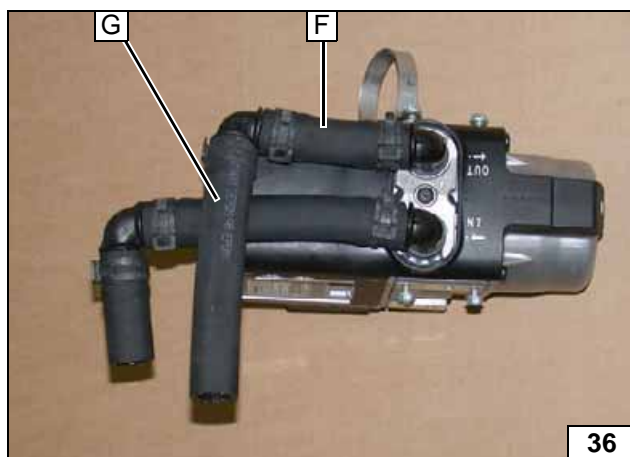

All spring clips = 25 mm dia.
All connecting pipes 90° and 18x18 mm dia.



Premounting hoses of heater outlet

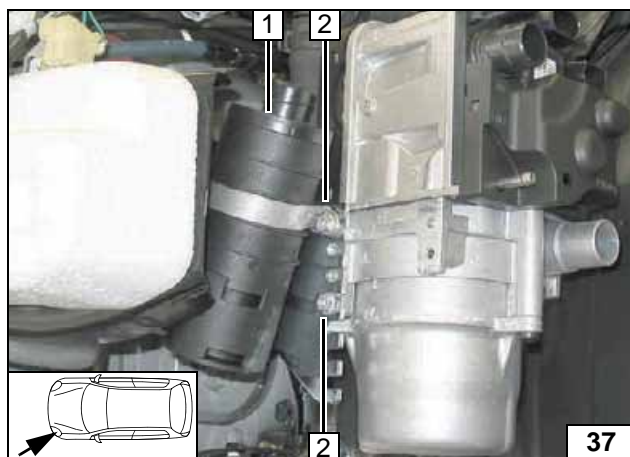

Installing Heater

- 1 Combustion air silencer
- 2 Tighten 5x13 self-tapping bolt [2x]

Installing Heater

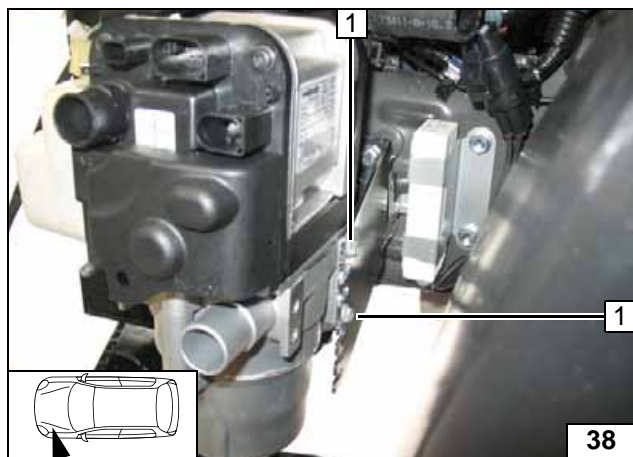

- 1 Tighten 5x13 self-tapping bolt [2x]

Installing
heater

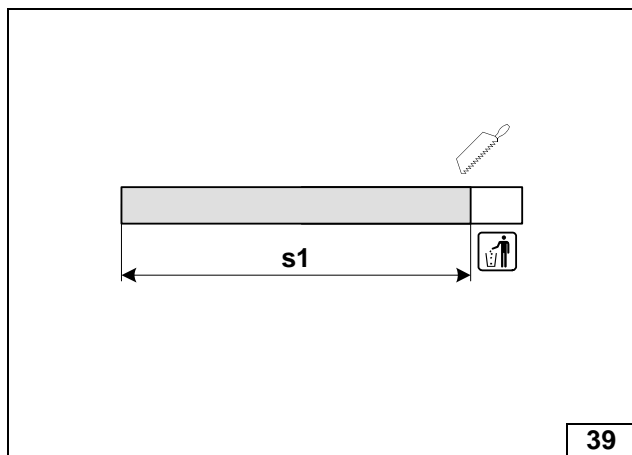
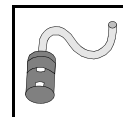

Combustion Air

s1 = 270

Cutting combustion air pipe to length

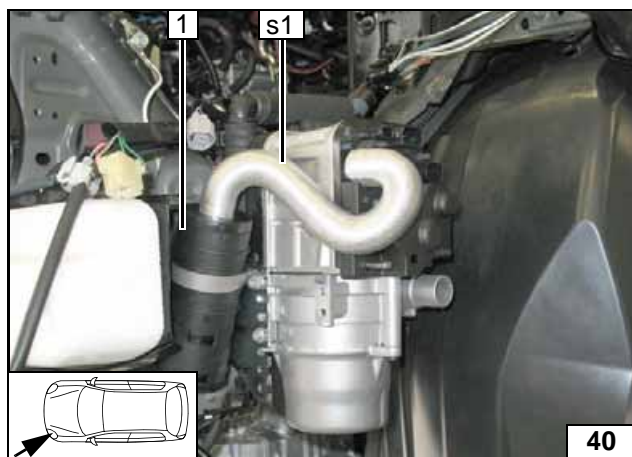

1 Silencer



Installing combustion air pipe s1

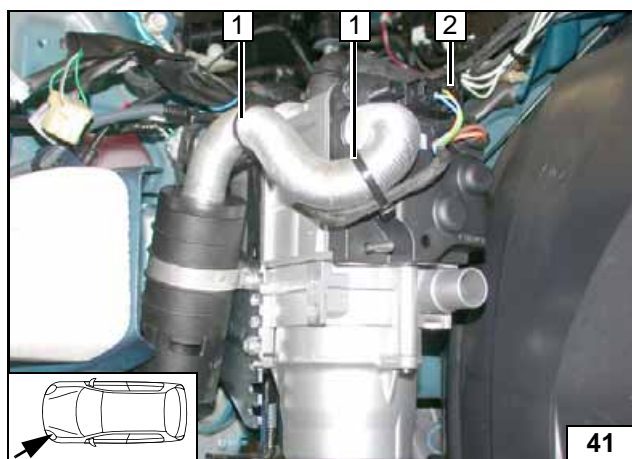

- 1 Cable tie
- 2 Installing heater wiring harness [2x]

Wiring harness of heater



Fuel



Open the vehicle's fuel tank cap, ventilate the tank and then re-close the tank lock.

Catch any fuel running off in an appropriate container.

Route fuel line and metering pump wiring harness so that they are protected against stone impact. Unless specified otherwise, always fasten using cable ties.



Provide rub protection for fuel line and wiring harness in areas where there are sharp edges.

The fuel line and wiring harness are routed to the metering pump as shown in the wiring harness routing diagram.

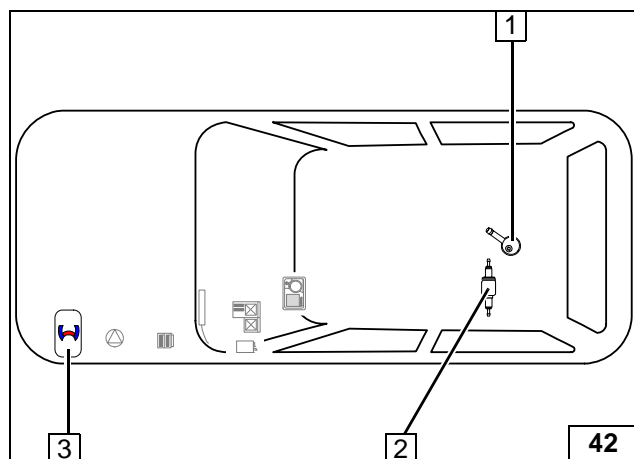

- 1 FuelFix
- 2 Metering pump
- 3 Heater



Installation overview

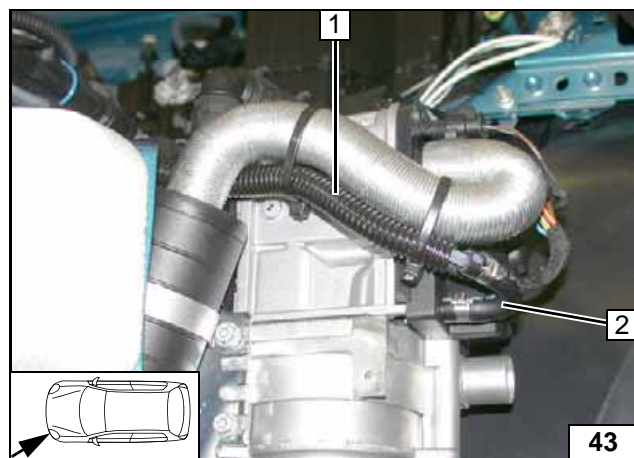

- 1 Fuel line and wiring harness of metering pump in corrugated tube
- 2 90° moulded hose, 10mm dia. clamp [2x]

Connecting heater

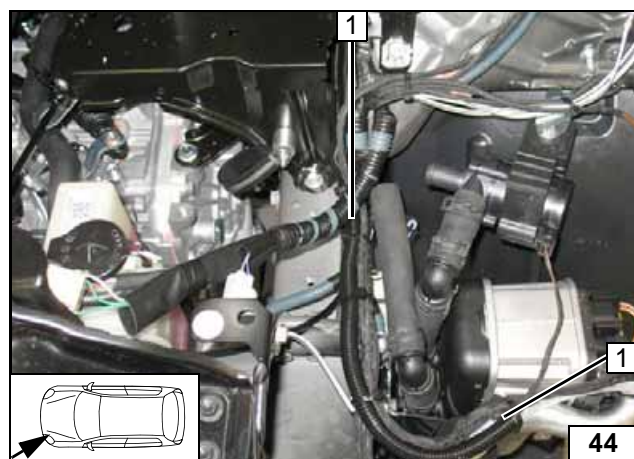

- 1 Route fuel line and wiring harness of metering pump in corrugated tube to firewall

Routing lines

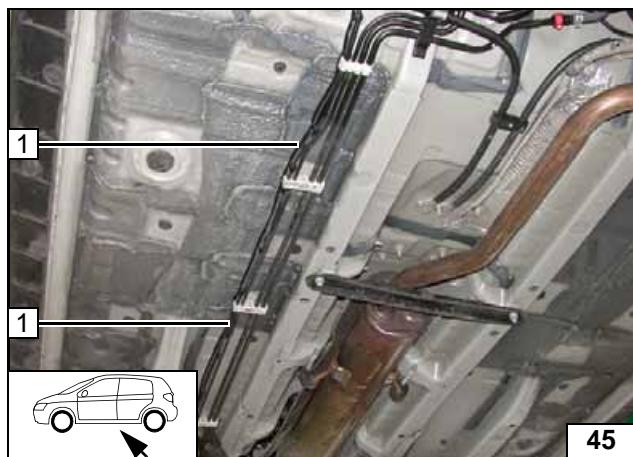

1 Fuel line and wiring harness of metering pump in corrugated tube

Routing lines

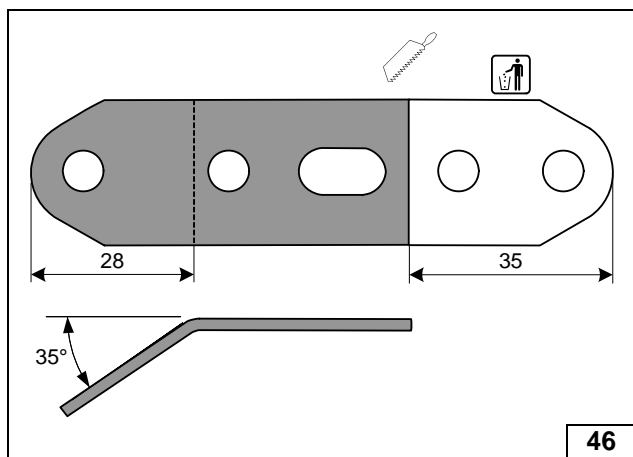

Preparing perforated bracket

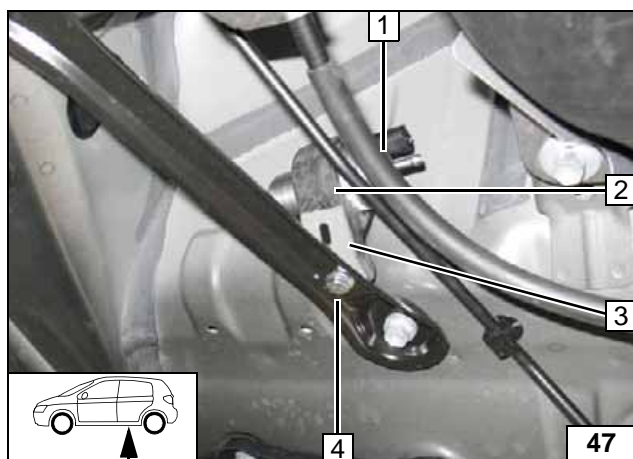

1 Metering pump
2 Metering pump mount
3 Perforated bracket
4 M6x25 bolt, existing hole in strut, support angle bracket, flanged nut

Installing metering pump

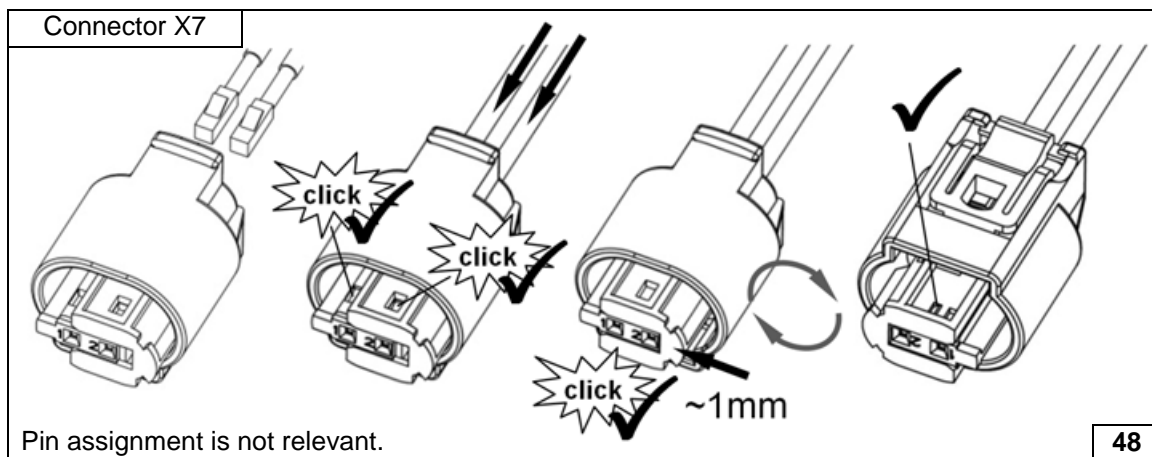

Pin assignment is not relevant.

Completing metering pump connector

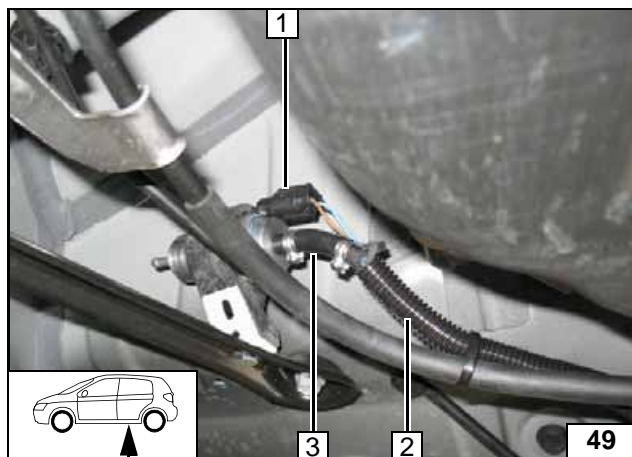
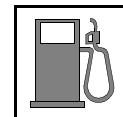

- 1 Metering pump wiring harness, connector X7 mounted
- 2 Fuel line of heater
- 3 Hose section, 10 mm dia. clamp [2x]



Connect-
ing meter-
ing pump

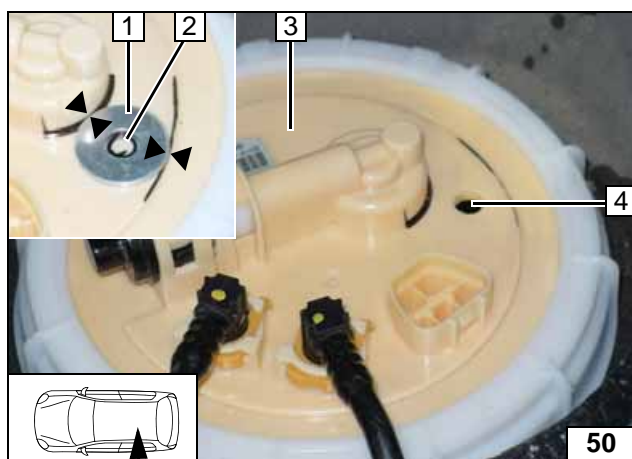

Installing FuelFix

Work steps F1, F2 and F3.

- 1 Position washer with outer dia. $d_a = 24\text{mm}$ as template against connection piece and marked raised part
- 2 Hole pattern
- 3 Fuel tank sending unit
- 4 Hole made with provided drill



Drilling
hole

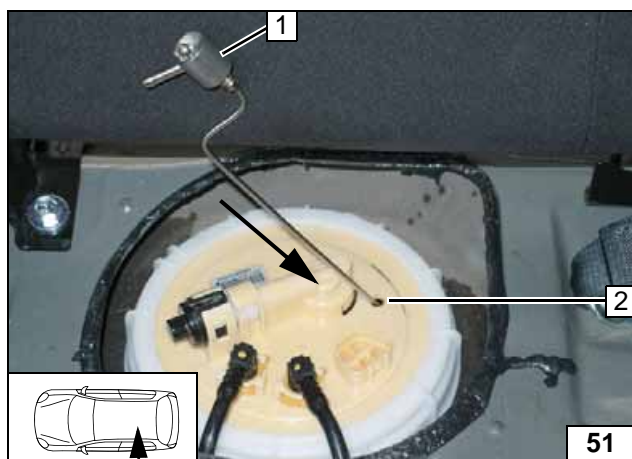

Work steps F4 and F5.

Bend FuelFix 1 according to template and cut to length.
Insert into hole 2.



Inserting
FuelFix

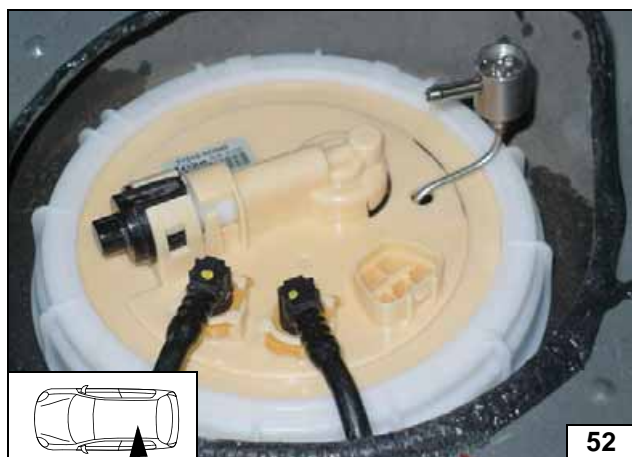

Inserting
FuelFix

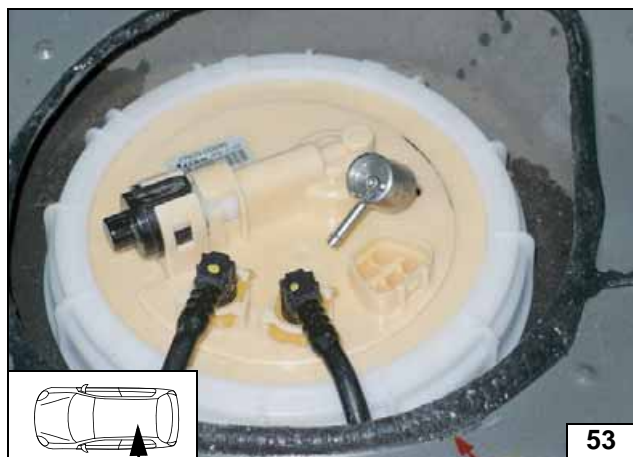

Inserting FuelFix

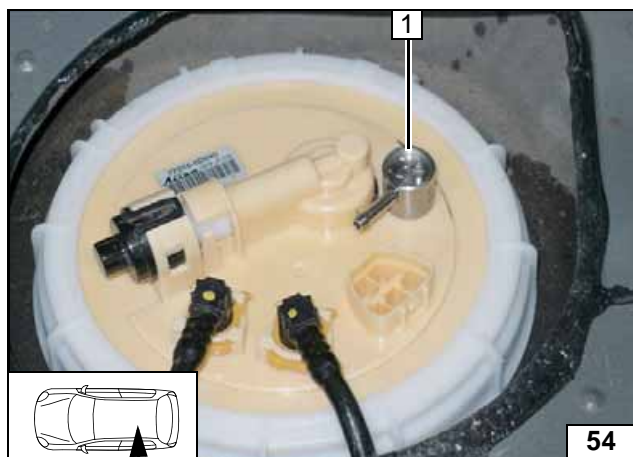

Work step F5.3, 5.4!

Position FuelFix 1 as shown!



Aligning FuelFix

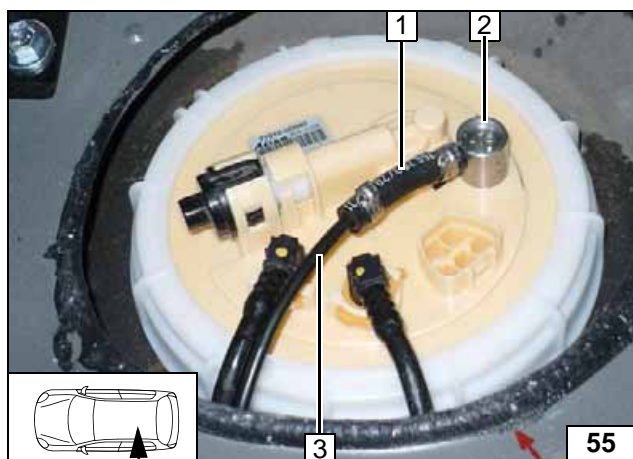

Work step F6.

- 1 Hose section, 10 mm dia. clamp [2x]
- 2 FuelFix
- 3 Fuel line

Connecting fuel line

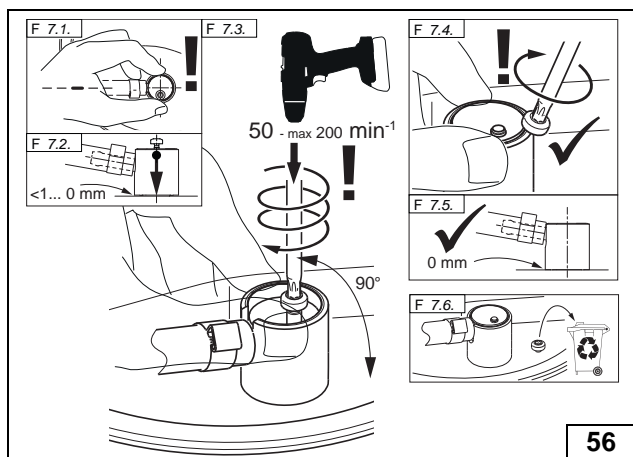

Work step F7.



Installing FuelFix

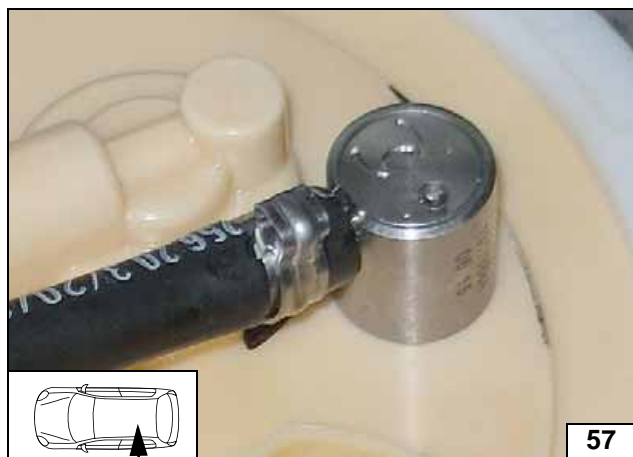

Work step F8.

Ensuring firm seating of FuelFix

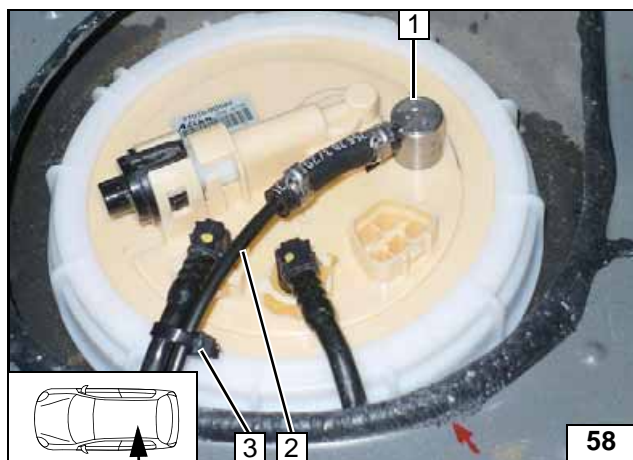

- 1 FuelFix installed
- 2 Fuel line of FuelFix
- 3 Cable tie as tension relief

Securing fuel line

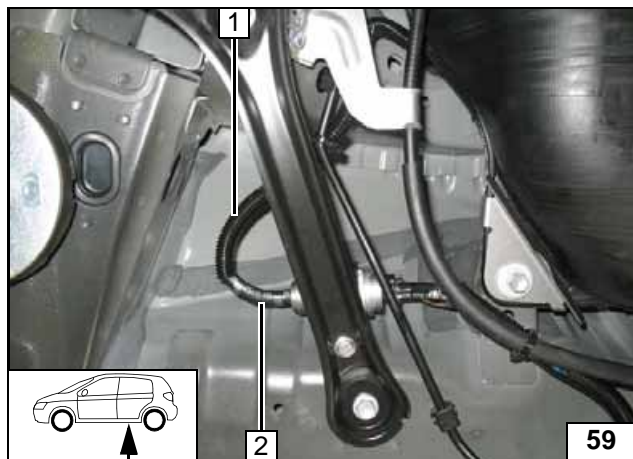

Check the position of the components; adjust if necessary. Check that they have freedom of movement.



- 1 Fuel line of FuelFix in corrugated tube
- 2 Hose section, 10 mm dia. clamp [2x]

Connecting metering pump



Coolant Circuit





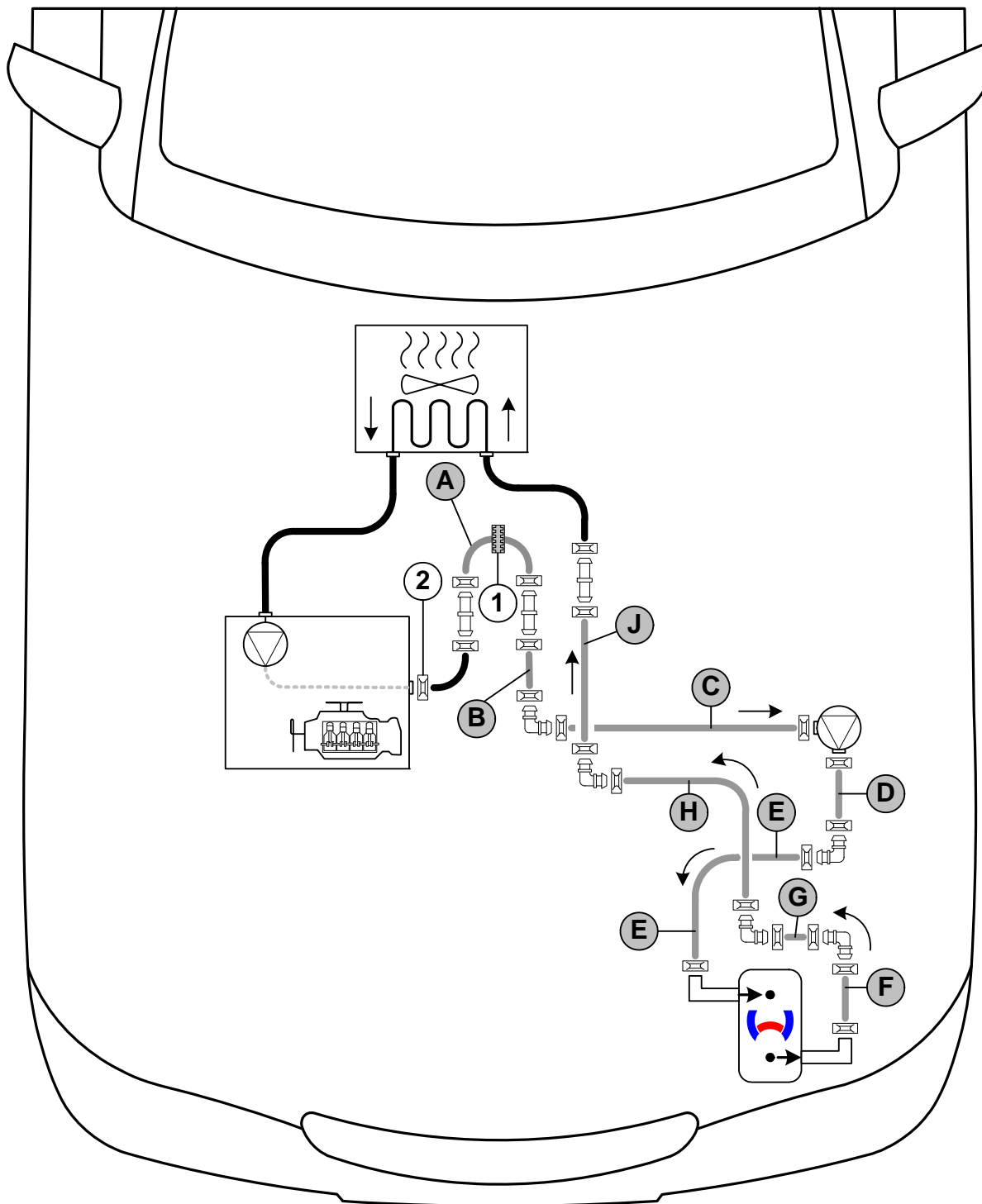

Any coolant running off should be collected in an appropriate container. Route hoses kink-free. Unless specified otherwise, always fasten using cable ties. Position clamps so that other hoses cannot be damaged. The heater must be filled with coolant when installing the hoses.

The connection should be modelled on an 'inline' circuit and based on the following diagram:



Hose routing diagram

All spring clips  = Ø 25 mm dia. All connecting pipes  and  = 18x18 mm dia.

1 = Black (sw) rubber isolator .

2 = Original vehicle spring clip .



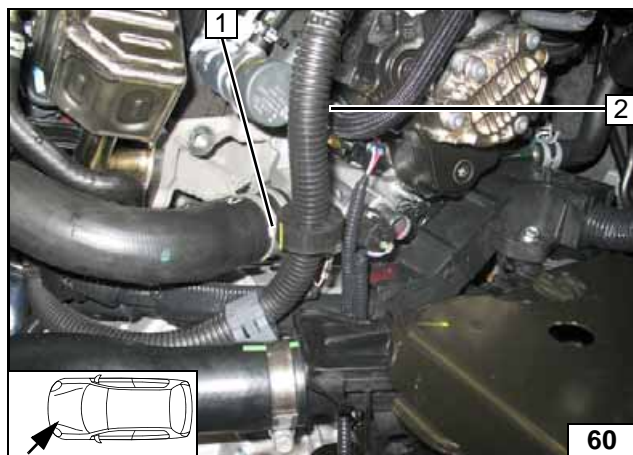
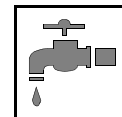

Detach positive wire **2** and slide on rubber isolator **1**.



Mounting rubber isolator

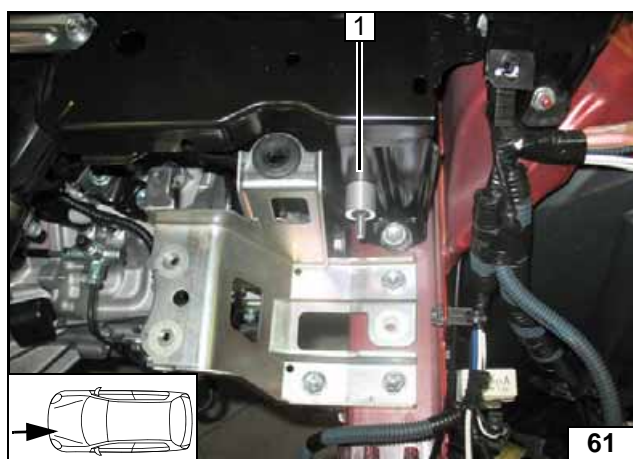

1 M6x40 bolt, large diameter washer, 20mm shim, lock washer, existing hole

Installing bolt

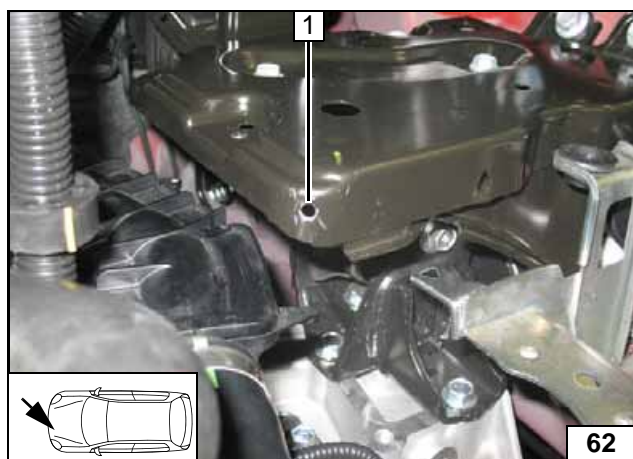

Drill 7 mm dia. hole **1** at centre of battery carrier



Preparing battery carrier

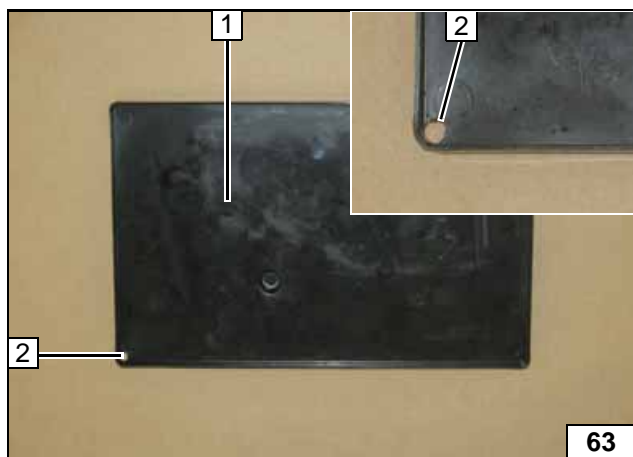

1 Battery support
2 7 mm dia. hole

Preparing battery support

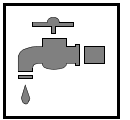

1 Paste foam base

Rub protection

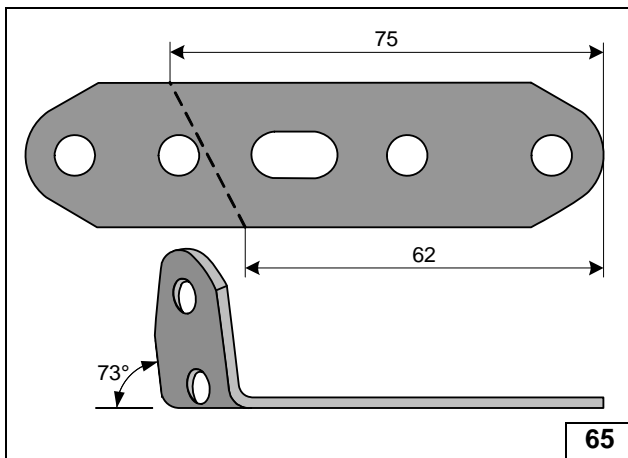

Bending perforated bracket

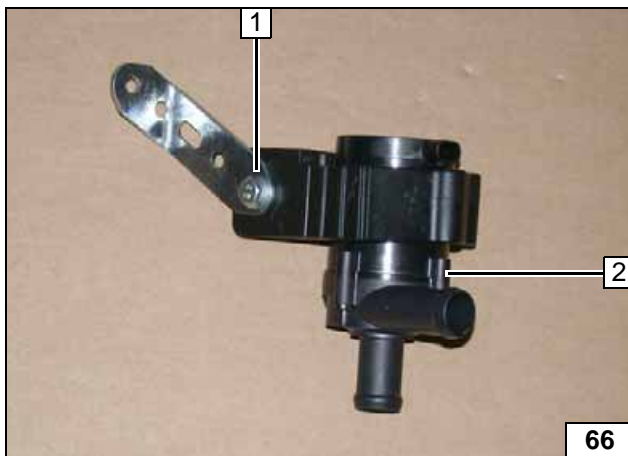

1 M6x25 bolt, perforated bracket, circulating pump mounting, flanged nut
2 Circulating pump

Preparing circulating pump

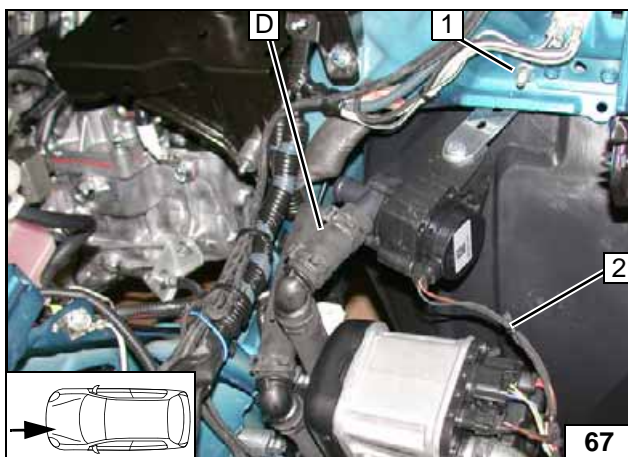

1 M6x20 bolt, perforated bracket, flanged nut, existing hole
2 Circulating pump wiring harness

Installing circulating pump

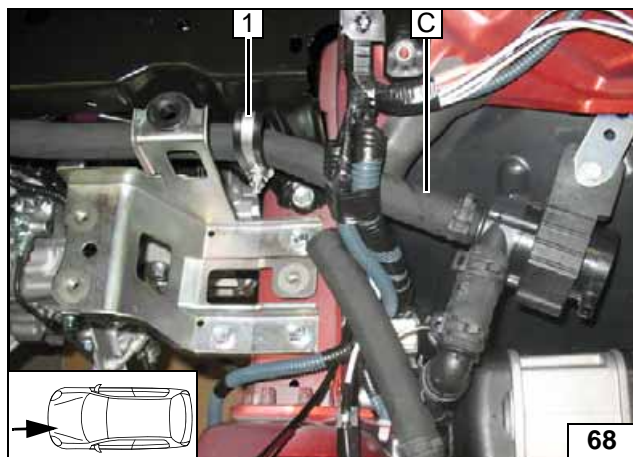

Route hose **C** through rubber-coated p-clamp **1**.



**Connect-
ing circu-
lating
pump**

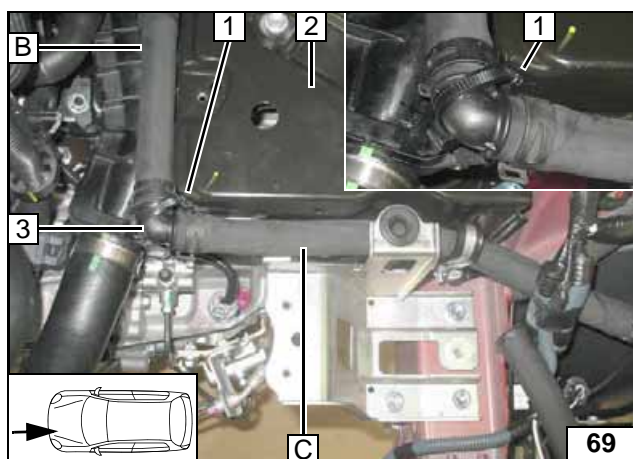

Attach connecting pipe **3** using eyelet cable tie **1** to battery carrier **2**.



**Routing in
engine
compart-
ment**

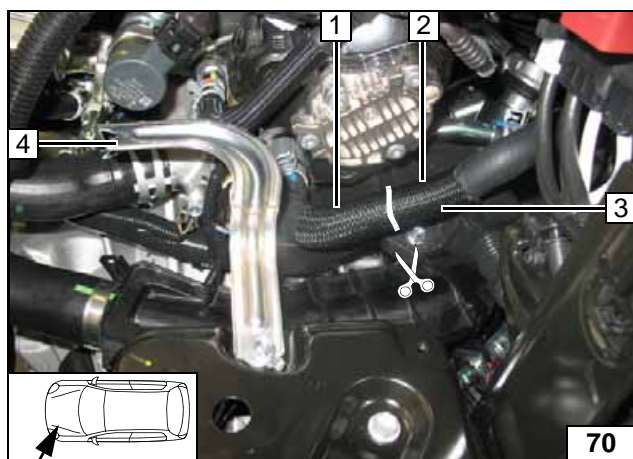

Remove braided protection hose at pos.**3**.



- 1** Engine outlet hose section
- 2** Hose section of heat exchanger inlet
- 4** Remove bracket and discard

**Cutting
point**

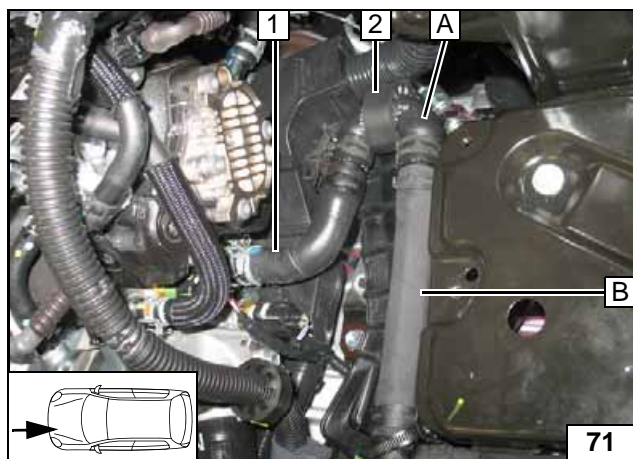

- 1** Engine outlet hose section
- 2** Rubber isolator

**Connect-
ing engine
outlet**

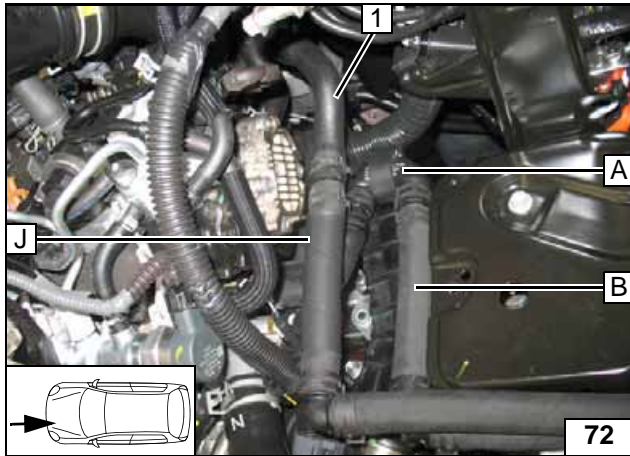

1 Hose section of heat exchanger inlet

Connect-
ing heat ex-
changer
inlet

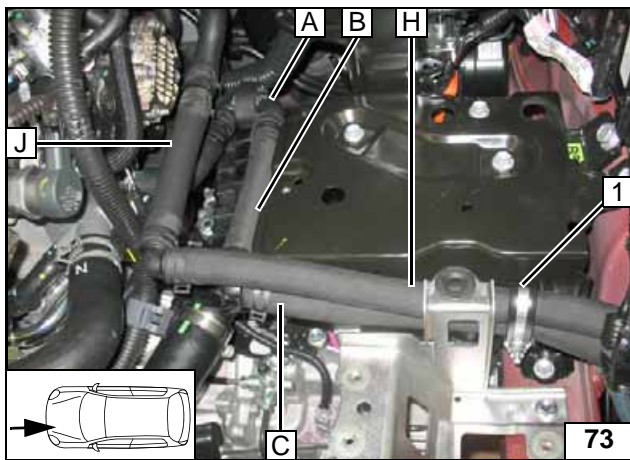

Route hose H through rubber-coated p-clamp 1.



1 Tighten rubber-coated p-clamp

Routing in
engine
compart-
ment

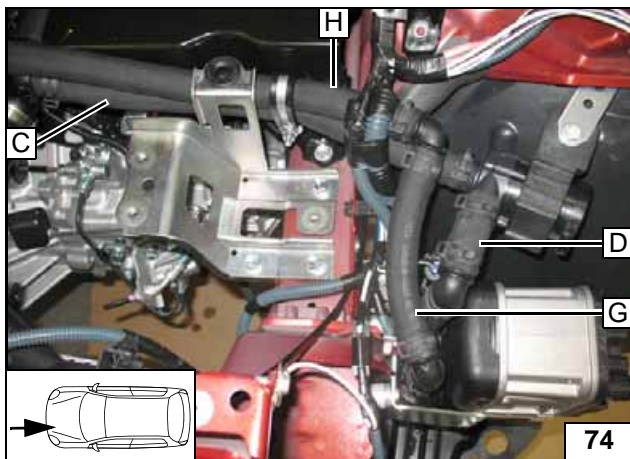

Routing in
engine
compart-
ment

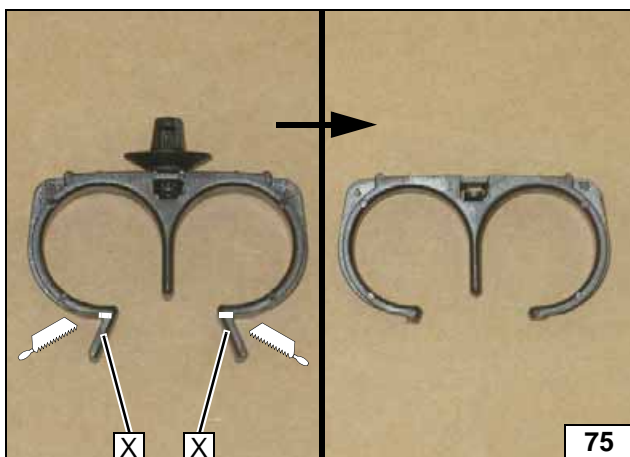

Adapt hose bracket as shown.



X =

Preparing
hose
bracket



Fix connecting pipe 1 with cable tie to battery carrier.

- 2 Hose bracket
- 3 Align rubber isolator



Routing in engine compartment

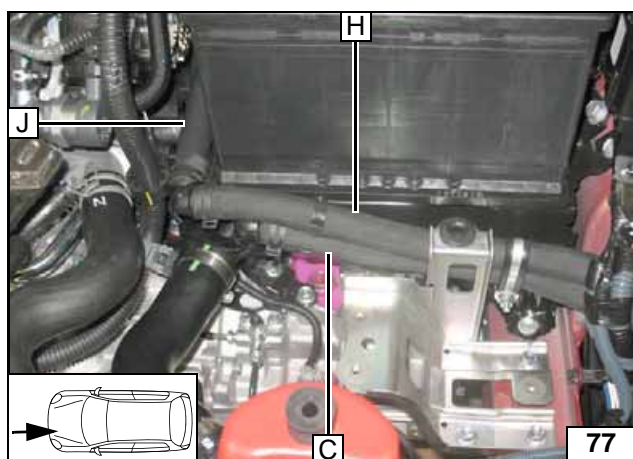

Align hoses.
Ensure sufficient distance from neighbouring components, correct if necessary.



Routing in engine compartment



Shorten pin 2 of air filter box 1 by 5mm.



Processing air filter box

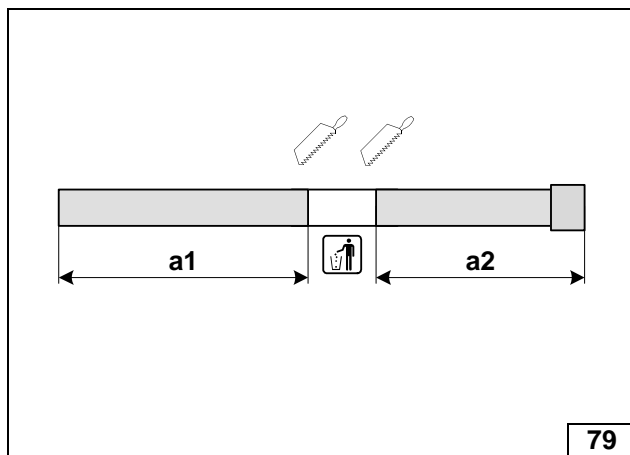
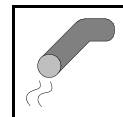

Exhaust Gas

$a_1 = 300$

$a_2 = 200$

Assigning/preparing exhaust pipe

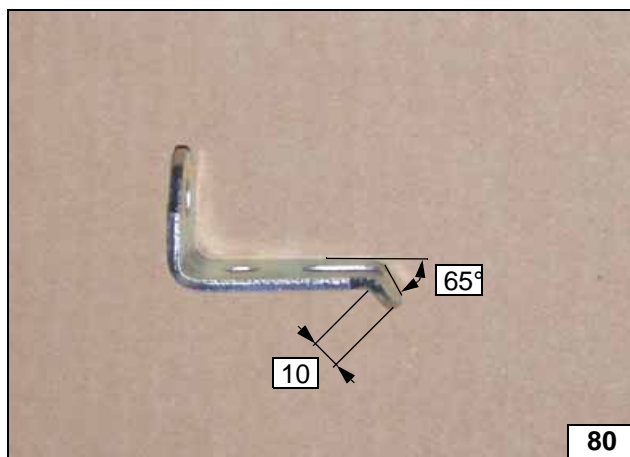

Bending angle bracket

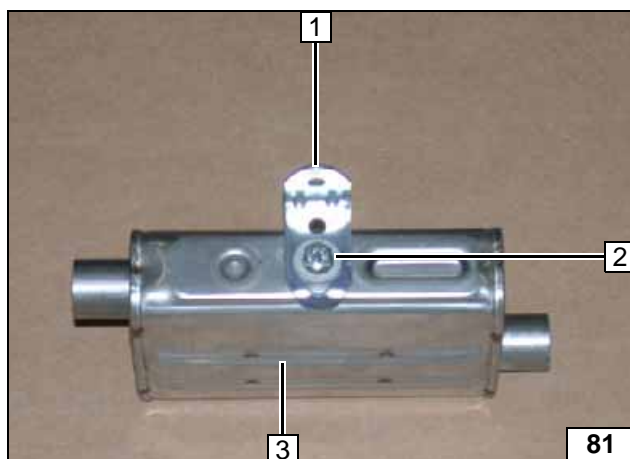

- 1 Angle bracket
- 2 M6x16 bolt, spring lockwasher, large diameter washer
- 3 Silencer

Premounting silencer

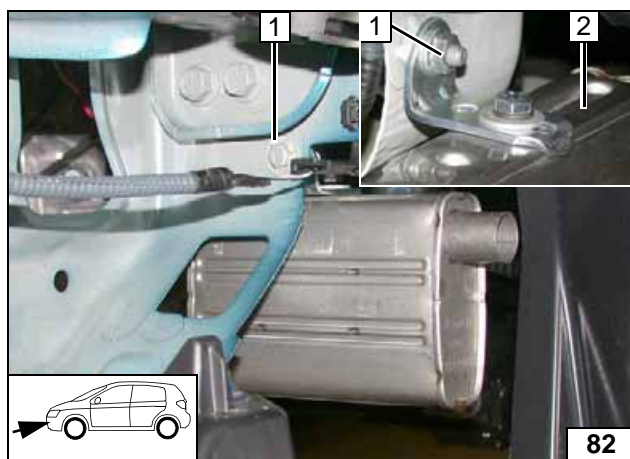

Remove original vehicle bolt at position 1 and discard.

- 1 M6x25 bolt, large diameter washer, flanged nut
- 2 Exhaust silencer



Installing silencer

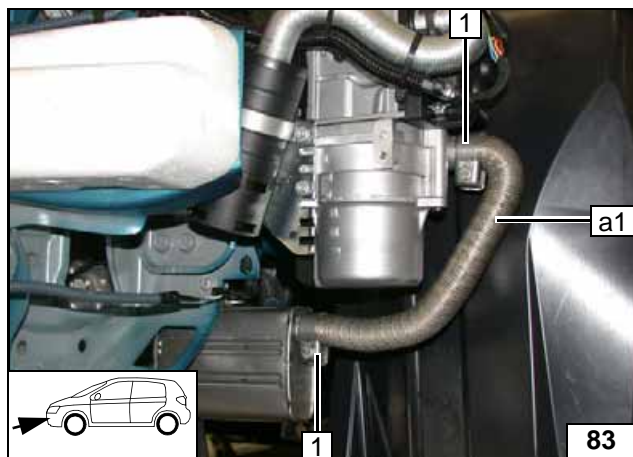
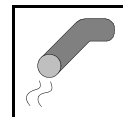

1 Hose clamp [2x]

Installing exhaust pipe a1

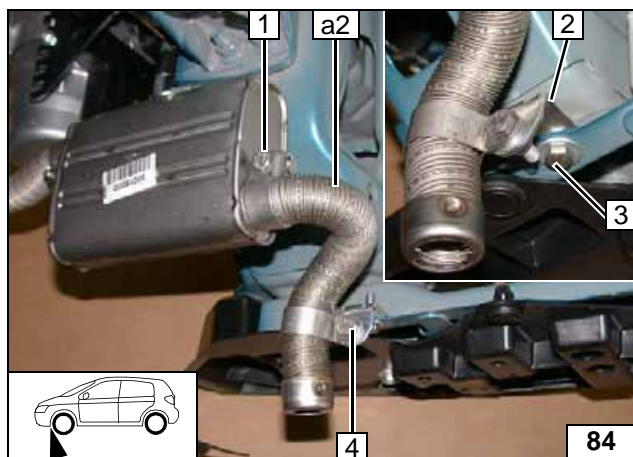

- 1 Hose clamp
- 2 Angle bracket
- 3 M6x20 bolt, large diameter washer, flanged nut, existing hole
- 4 M6x20 bolt, pipe clamp, flanged nut

Installing exhaust pipe a2

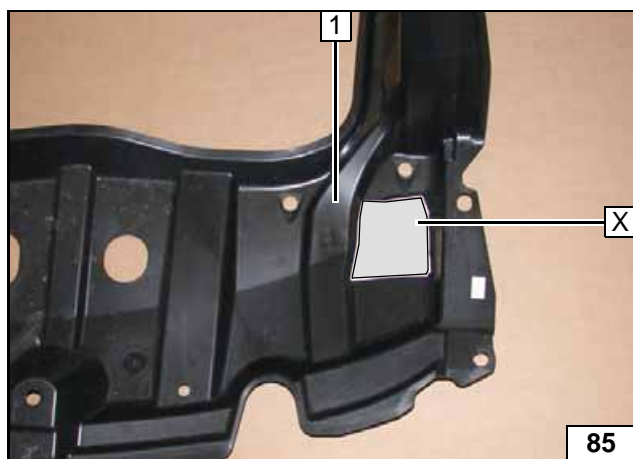

1 Underride protection

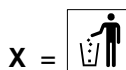

Cutting out underride protection

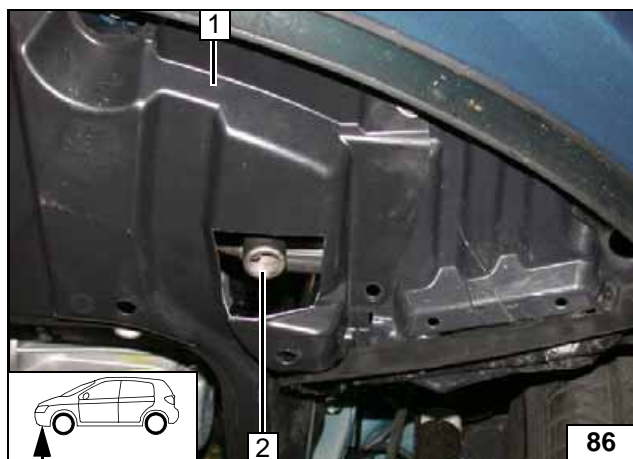

Install underride protection 1. Align exhaust pipe a2 at centre of recess and flush with underride protection 1. Ensure sufficient distance from neighbouring components.



Aligning exhaust pipe a2



Final Work



Reassemble the components in reverse order. Check all hoses, clamps and all electrical connections for firm seating. Insulate loose wire ends and tie back.
Only use manufacturer-approved coolant. Spray the heater components with anti-corrosion wax (Tectyl 100K).

- **Connect the battery.**
- **Fill and bleed the coolant circuit according to the vehicle manufacturer's specifications.**
- **Program MultiControl CAR, teach Telearstart transmitter.**
- **Make settings on A/C control panel according to the 'Operating Instructions for End Customer'.**
- **Check the proper operation of the parking heater, see the operating instructions/installation instructions.**
- **Place the 'Switch off parking heater before refuelling' caution label near the filler neck.**

Proceed as follows with the Webasto Thermo Test Diagnosis during initial start-up:

- **Control coolant pump under Menu Component test, check coolant level**
- **Pre-feed fuel for the heater using the line filling menu.**
- **Check CO₂ settings; take setting values from the general installation instructions**
- **During the trial run, all water and fuel connections must be checked for leakage and firm seating**
- **Conduct troubleshooting in case of malfunctions.**

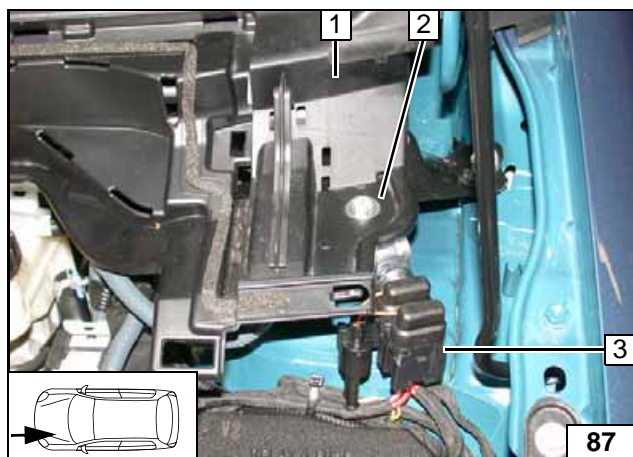

- 1 Mount coolant reservoir cap
- 2 M6x16 bolt, large diameter washer, flanged nut, existing hole
- 3 Engine compartment fuse holder



Installing fuse holder

Webasto Thermo & Comfort SE
Postfach 1410
82199 Gilching
Germany
Internet: www.webasto.com
Technical Extranet:
<http://dealers.webasto.com>

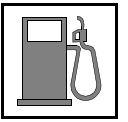

FuelFix Template

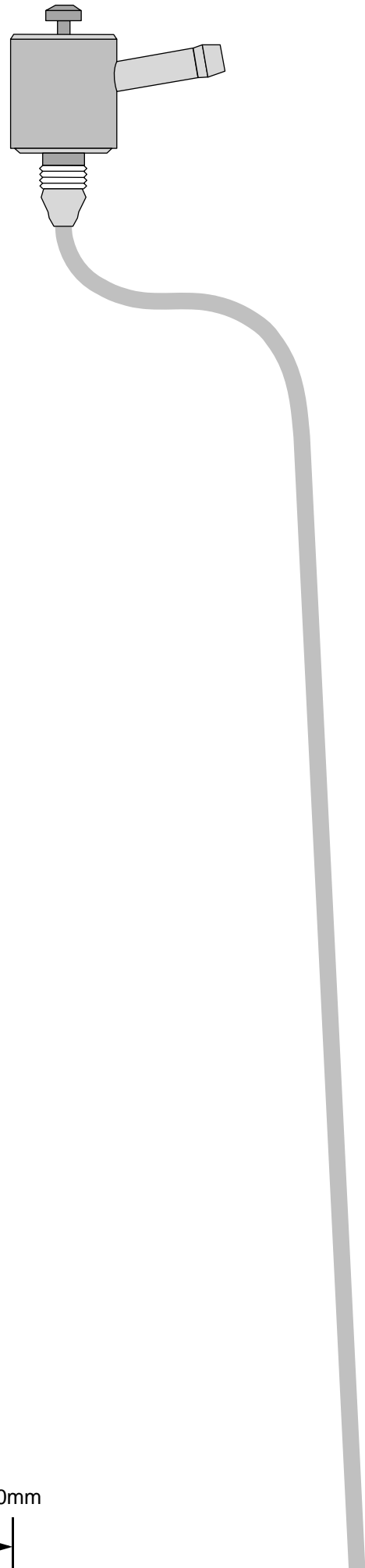

Top view

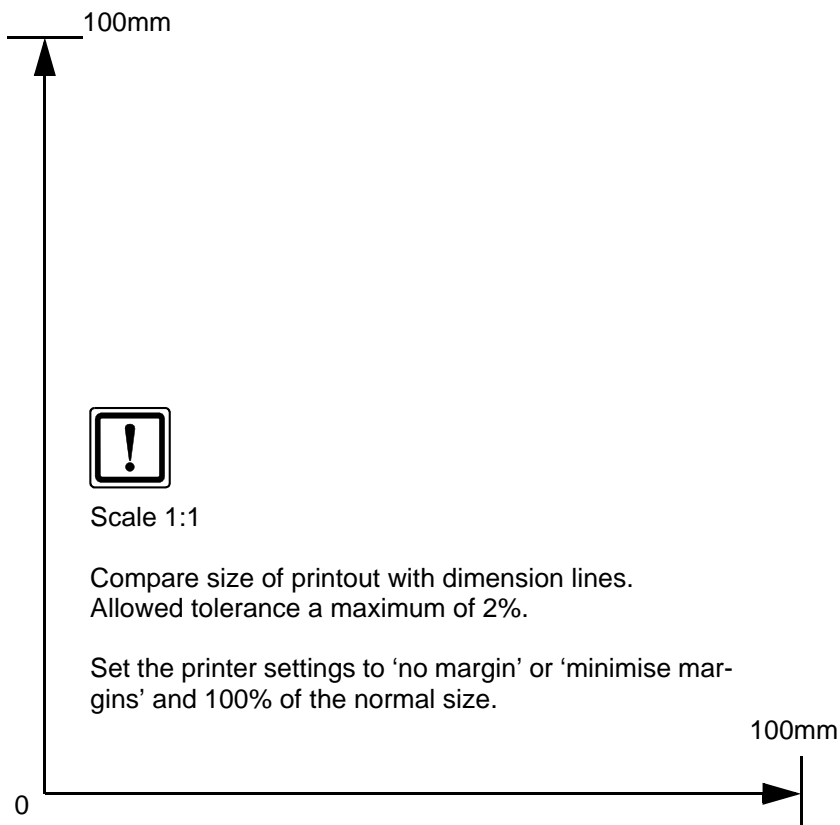
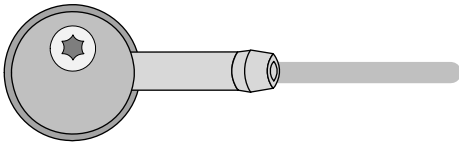

Scale 1:1

Compare size of printout with dimension lines.
Allowed tolerance a maximum of 2%.

Set the printer settings to 'no margin' or 'minimise margins' and 100% of the normal size.

Operating Instructions for Manual Air-Conditioning

Please remove page and add to the vehicle operating instructions.

Note:

We recommend matching the heating time to the driving time.

Heating time = driving time

Example:

For a driving time of approx. 20 min. (in one direction), we recommend not exceeding a switch-on time of 20 min.

Passenger compartment monitoring, if installed, must be deactivated in addition to the vehicle settings for the heating operation.

For instructions on deactivation, please refer to the operating instructions of the vehicle.

Before parking the vehicle, make the following settings:

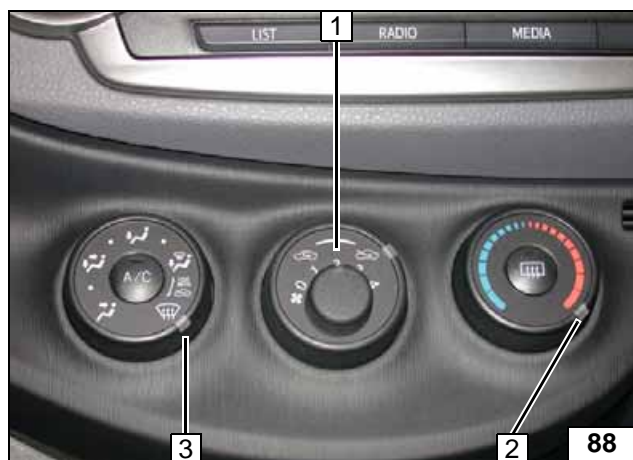

- 1 Set fan to level '1', or max. '2'
- 2 Set temperature to 'max.'
- 3 Air outlet to windscreen

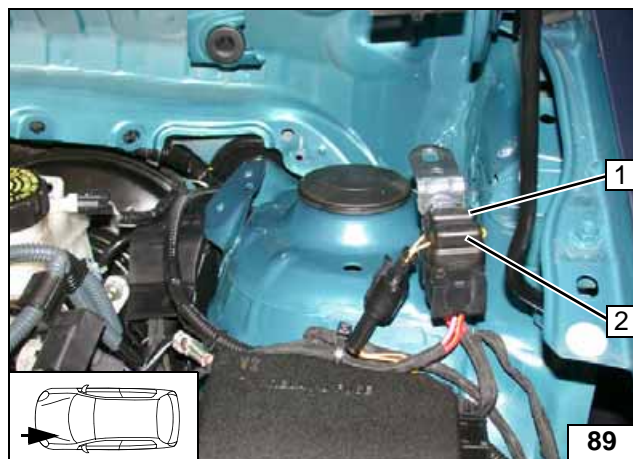

- 1 30A passenger compartment main fuse F2
- 2 20A heater fuse F1

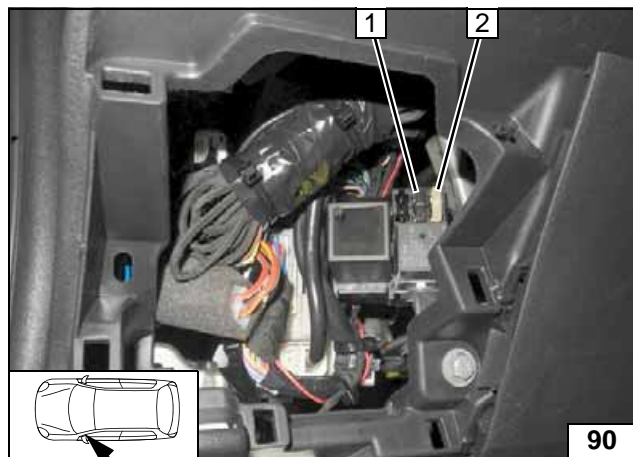

- 1 1A heater control fuse F3
- 2 25A fan fuse F4



A/C control panel

Engine compartment fuses

Passenger compartment fuses



Operating Instructions for Automatic Air-Conditioning

Please remove page and add to the vehicle operating instructions.

Note:

We recommend matching the heating time to the driving time.

Heating time = driving time

Example:

For a driving time of approx. 20 min. (in one direction), we recommend not exceeding a switch-on time of 20 min.

Passenger compartment monitoring, if installed, must be deactivated in addition to the vehicle settings for the heating operation.

For instructions on deactivation, please refer to the operating instructions of the vehicle.

Before parking the vehicle, make the following settings:



- 1 Set temperature to 'HI'
- 2 Air outlet to windscreen
- 3 Set fan to level '1', or max. '2'



A/C control panel

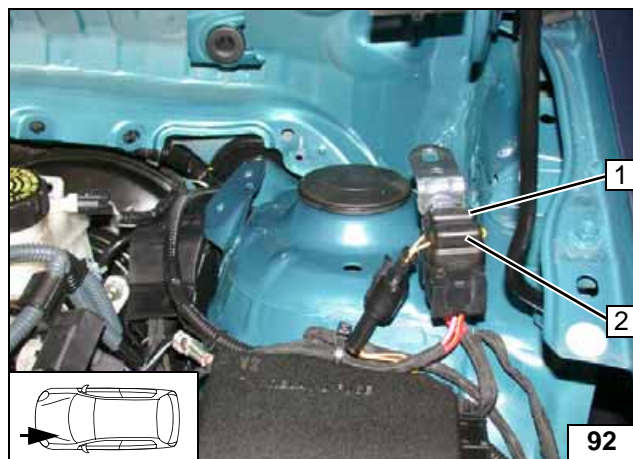

- 1 30A passenger compartment main fuse F2
- 2 20A heater fuse F1

Engine compartment fuses

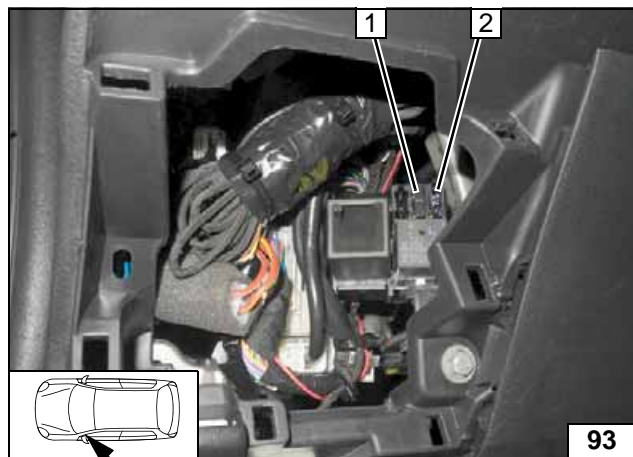

- 1 1A heater control fuse F3
- 2 7.5A fan fuse F4

Passenger compartment fuses