

## Cold start kit

Thermo Top Evo parking heater



## Installation documentation Jeep Renegade

### Validity

Manufacturer	Model	Type	Model year	EG BE No. / ABE
Jeep	Renegade	BU	From model year 2015	e3 * 2007 / 46 * 0300 * ...

Motorisation	Fuel	Emission standard	Transmission type	Output in kW	Displacement in cm <sup>3</sup>	Engine code
1.6 D	Diesel	Euro 6	SG	88	1598	EJK
2.0 D	Diesel	Euro 6	AG	103	1956	EBT
2.0 D	Diesel	Euro 6	SG	125	1956	EBT
2.0 D	Diesel	Euro 6	AG	125	1956	EBT

SG = manual transmission

AG = automatic transmission

**Left-hand drive vehicle**

# Jeep Renegade

## Table of contents

Validity	1	Electrical system	5
Necessary components	2	Preparing electrical system	6
Information on validity	2	System wiring diagram	8
Installation overview	2	Cold start system installation	9
Information on operating and installation instructions	3	Final work	13
Information on validity	4		
Technical information	4		
Explanatory notes on document	4		
Preliminary work	5		

## Necessary components

Description	Order No.:
Additional cold start kit for Jeep Renegade 2015 diesel	1325525C
Cold start kit installation documentation for Jeep Renegade 2015 diesel	1325526D

## Information on validity

This installation documentation applies only in combination with:

Description	Order No.:
Installation kit (incl. cold start kit) for Jeep Renegade 2015 diesel	1323609_
Installation documentation for Jeep Renegade 2015 diesel	1323610_

## Installation overview

### Legend:

1. CLR Module
2. Temperature sensor (RTD)
3. Adapter connector

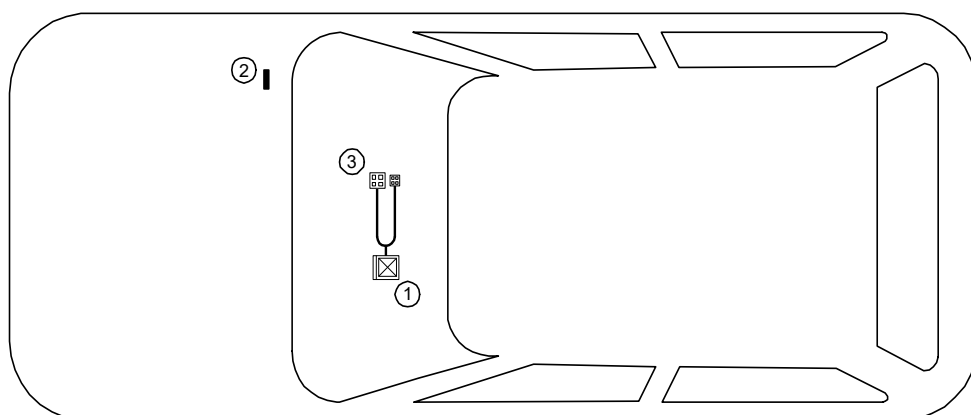

## Information on operating and installation instructions

### 1 Important information (not complete)

#### 1.1 Installation and repair



The improper installation or repair of Webasto heating and cooling systems can cause fire or the leakage of deadly carbon monoxide, leading to serious injury or death.



To install and repair Webasto heating and cooling systems you need to have completed a special company training course and have the appropriate technical documentation, special tools and special equipment.



Installation and repair may ONLY be carried out by persons trained and certified in a Webasto training course. NEVER try to install or repair Webasto heating or cooling systems if you have not completed a Webasto training course, you do not have the necessary technical skills and you do not have the technical documentation, tools and equipment available to ensure that you can complete the installation and repair work properly.

Only use genuine Webasto parts. See the Webasto air and water heaters accessories catalogue for this purpose.

#### 1.2 Operation

To ensure safe operation, we recommend having the heater checked every two years by an authorised Webasto dealer, especially when used over a long period and/or under extreme environmental conditions.

Do not operate the heater in closed rooms due to the danger of poisoning and suffocation.

Always switch off the heater before refuelling.

The heater may only be used with the prescribed fuel diesel (DIN EN 590) or petrol (DIN EN 228).

The heater may not be cleaned with a high-pressure cleaner.

#### 1.3 Please note

ALWAYS follow all Webasto installation and operating instructions and observe all warnings.

To become familiar with and understand all functions and properties of the heater, the operating instructions must be read carefully and observed at all times.

For proper, safe installation and repair work, the installation instructions with all warnings and safety information must be carefully read and observed at all times. Please always contact a workshop authorised by Webasto for all installation and repair work.

#### Important

**Webasto shall assume no liability for defects, damage and injuries resulting from a failure to observe the installation, repair and operating instructions of the information contained in them.**

**This liability exclusion particularly applies to improper installations and repairs, installations and repairs by untrained persons or in the case of a failure to use genuine spare parts.**

**The liability due to culpable disregard to life, limb or health and due to damage or injuries caused by a wilful or reckless breach of duty remain unaffected, as does the obligatory product liability.**

Installation should be carried out according to the general, standard rules of technology. Unless specified otherwise, fasten hoses, lines and wiring harnesses to original vehicle lines and wiring harnesses using cable ties. Insulate loose wire ends and tie back. Connectors on electronic components have to audibly click into place during installation.

Sharp edges should be fitted with rub protection. Spray unfinished body areas, e.g. drilled holes, with anti-corrosion wax (Tectyl 100K).

Observe the instructions and guidelines of the respective vehicle manufacturer for demounting and mounting vehicle specific components!

The initial start-up is to be executed with the Webasto Thermo Test Diagnosis.

When installing a programmable control module (e.g. a PWM Gateway), the corresponding settings must be checked or adjusted.

### 2 Statutory regulations governing installation

Guidelines	Thermo Top Evo
Heating Directive ECE R122	E1 00 0258
EMC Directive ECE R10	E1 04 5627

#### Note

The regulations of these guidelines are binding in the scope of the Directive 70/156/EEC and/or 2007/46/EC (for new vehicle models from 29/04/2009) and should also be observed in countries in which there are no special regulations.

#### Important

Failure to follow the installation instructions will result in the invalidation of the type approval for the heater and therefore invalidation of the general **homologation of the vehicle**.

#### Note

The heater is licensed in accordance with paragraph 19, section 3, No. 2b of the StVZO (German Road Traffic Licensing Authority).

### 2.1 Excerpt from ECE regulation 122 (heating system) paragraph 5 for the installation of the heater

Beginning of excerpt.

#### ANNEX VII

#### REQUIREMENTS FOR COMBUSTION HEATERS AND THEIR INSTALLATION

##### 1. GENERAL REQUIREMENTS

1.7.1. A clearly visible tell-tale in the operator's field of view shall inform when the combustion heater is switched on or off.

##### 2. VEHICLE INSTALLATION REQUIREMENTS

###### 2.1. Scope

2.1.1. Subject to paragraph 2.1.2, combustion heaters shall be installed according to the requirements of this Annex.

2.1.2. Vehicles of category O having liquid fuel heaters are deemed to comply with the requirements of this Annex.

###### 2.2. Positioning of heater

2.2.1. Body sections and any other components in the vicinity of the heater must be protected from excessive heat and the possibility of fuel or oil contamination.

2.2.2. The combustion heater shall not constitute a risk of fire, even in the case of overheating. This requirement shall be deemed to be fulfilled if the installation ensures an adequate distance to all parts and suitable ventilation, by the use of fire resistant materials or by the use of heat shields.

2.2.3. In the case of M2 and M3 vehicles, the heater must not be positioned in the passenger compartment. However, an installation in an effectively sealed envelope which also complies with the conditions in paragraph 2.2.2 may be used.

2.2.4. The label referred to in paragraph 1.4 or a duplicate, must be positioned so that it can be easily read when the heater is installed in the vehicle.

2.2.5. Every reasonable precaution should be taken in positioning the heater to minimise the risk of injury and damage to personal property.

###### 2.3. Fuel supply

2.3.1. The fuel filler must not be situated in the passenger compartment and must be provided with an effective cap to prevent fuel spillage.

2.3.2. In the case of liquid fuel heaters, where a supply separate to that of the vehicle is provided, the type of fuel and its filler point must be clearly labelled.

2.3.3. A notice, indicating that the heater must be shut down before refuelling, must be affixed to the fuelling point. In addition a suitable instruction must be included in the manufacturer's operating manual.

###### 2.4. Exhaust system

2.4.1. The exhaust outlet must be located so as to prevent emissions from entering the vehicle through ventilators, heated air inlets or opening windows.

###### 2.5. Combustion air inlet

2.5.1. The air for the combustion chamber of the heater must not be drawn from the passenger compartment of the vehicle.

2.5.2. The air inlet must be so positioned or guarded that blocking by rubbish or luggage is unlikely.

###### 2.6. Heating air inlet

2.6.1. The heating air supply may be fresh or recirculated air and must be drawn from a clean area not likely to be contaminated by exhaust fumes emitted either by the propulsion engine, the combustion heater or any other vehicle source.

2.6.2. The inlet duct must be protected by mesh or other suitable means.

###### 2.7. Heating air outlet

2.7.1. Any ducting used to route the hot air through the vehicle must be so positioned or protected that no injury or damage could be caused if it were to be touched.

2.7.2. The air outlet must be so positioned or guarded that blocking by rubbish or luggage is unlikely.

End of excerpt.

In multilingual versions the German language is binding.

# Jeep Renegade

## Information on validity

This installation documentation applies to Jeep Renegade diesel vehicles - for validity, see page 1 - from model year 2015 and later, assuming technical modifications to the vehicle do not affect installation, any liability claims excluded. Depending on the vehicle version and equipment, modifications may be necessary during installation with respect to this installation documentation.

Vehicle and engine types, equipment variants and other specifications not listed in this installation documentation have not been tested. However, installation according to this installation documentation may be possible.

## Technical information

### Special tools

- Automatic wire stripper, 0.2 - 6mm<sup>2</sup>
- Crimping pliers for male connector, 0.14 - 6mm<sup>2</sup>
- Crimping pliers for cable lug, 0.5 - 10mm<sup>2</sup>
- Crimping pliers for connector, 0.25 - 6mm<sup>2</sup>
- Torque wrench for 2.0 - 10 Nm
- Webasto Thermo Test Diagnosis with current software

### Dimensions

- All dimensions are in mm.

### Tightening torque values

Tighten bolt connections in accordance with manufacturer's instructions or in accordance with state-of-the-art-technology.

## Explanatory notes on document

You will find an identification mark on the outside top right corner of the page in question to provide you with a quick overview of the individual working steps.

### Mechanics

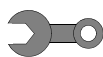

### Electrics



Special features are highlighted using the following symbols:

Specific risk of damage to components.



Specific risk due to electrical voltage.



Specific risk of fire or explosion.



Reference to a special technical feature.



The arrow in the vehicle icon indicates the position on the vehicle and the viewing angle.

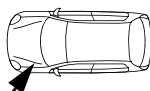

Reference to the manufacturer's vehicle-specific documents.



Reference to specific installation instructions of Webasto components (demonstrated with the example of the FuelFix).



Reference to general installation instructions of Webasto components.



Tightening torque according to the manufacturer's vehicle-specific documents.



# Jeep Renegade

## Preliminary work

### Vehicle



- Disconnect the battery.
- Remove the windscreen wipers.
- Remove the water drain chamber cover.
- Remove the wiring harness pass through trim for the firewall on the left (5x clipped on).
- Remove the side trim of the instrument panel on the left and on the right.
- Remove the footwell trim on the driver's and front passenger's sides.
- Remove the glove box.



## Electrical system

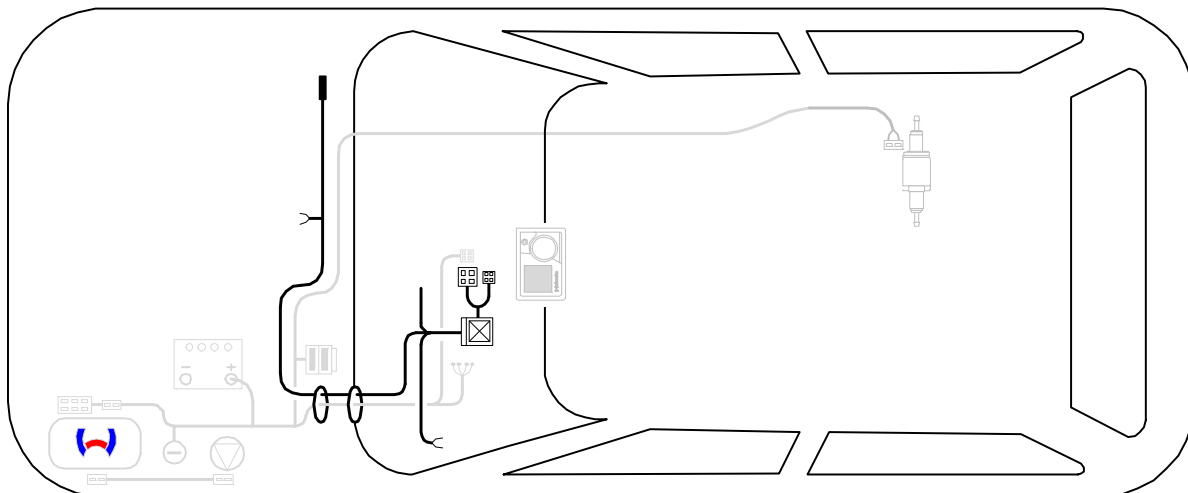

Wiring harness routing diagram for passenger compartment

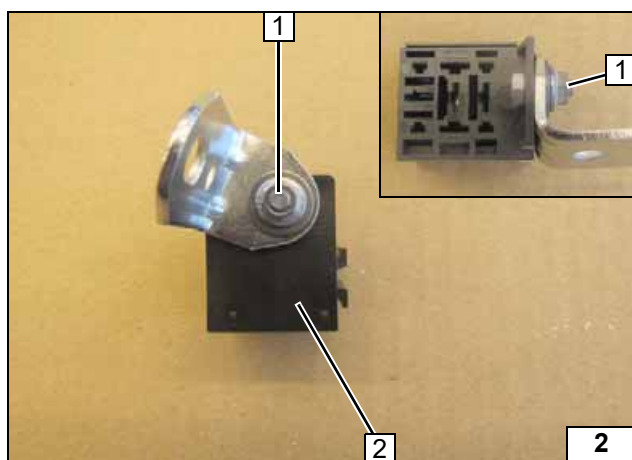
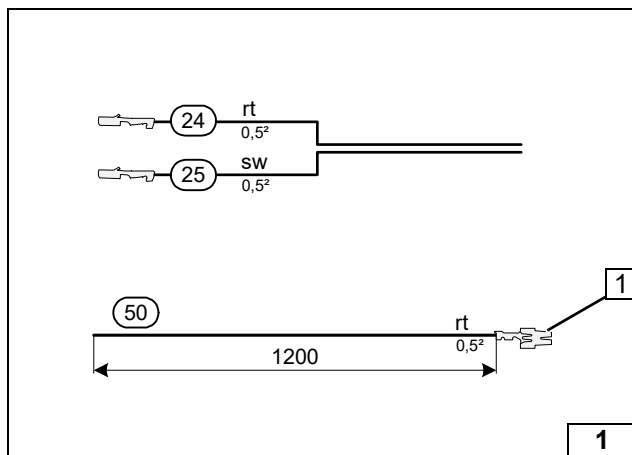

## Preparing electrical system



Wire sections retain their numbering in the entire document.

Produce all following electrical connections as shown in the system wiring diagram.

Pull wire (50) into provided protective sleeving.

- 1 Flat spring contact
- 24 Red (rt) wire of cold start wiring harness
- 25 Black (sw) wire of cold start wiring harness
- 1 M5x16 bolt, large diameter washer, flanged nut
- 2 CLR module socket (wires are not shown)

## Assigning wires

## Premounting angle bracket

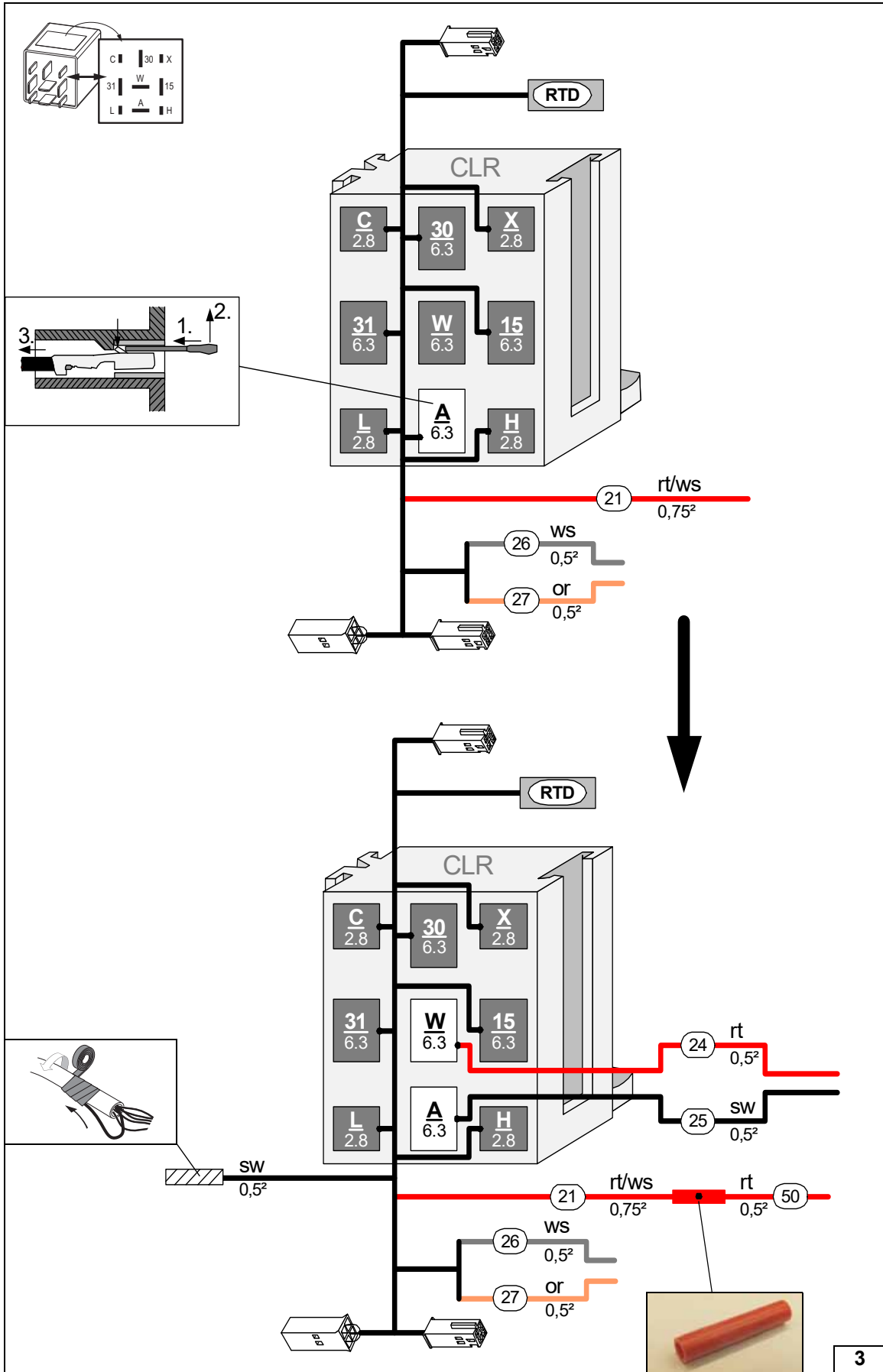

Disconnecting black (sw) wire from A / assignment of wires to be used



Insulating black (sw) wire / connecting wires / connecting red (rt) wire (50) with red/white (rt/ws) wire (21)

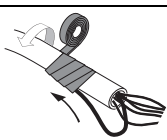

3



System wiring diagram

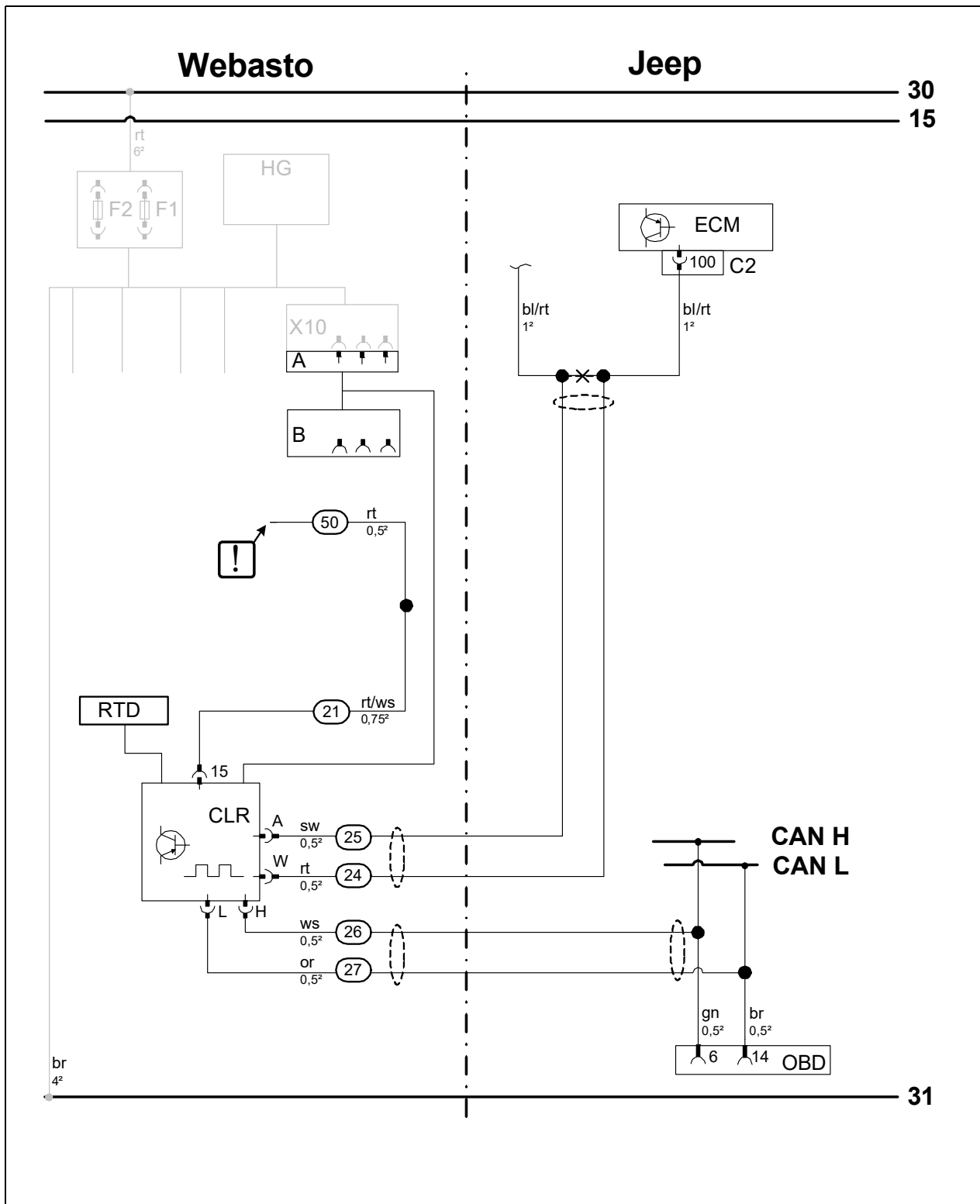

System wiring diagram for all vehicles





Webasto components		Vehicle components		Colours and symbols	
HG	TT-Evo heater	ECM	Engine control unit	rt	red
F1	20A fuse	C2	120-pin connector of ECM	sw	black
F2	30A fuse	OBD	On-board diagnostics	gn	green
X10	4-pin female connector of control element			or	orange
A	Connector of CLR module wiring harness			ws	white
B	Female connector of CLR module wiring harness			br	brown
				bl	blue
RTD	Temperature sensor			The connection is made when integrating the A/C control	
CLR	CLR Module				
				X	Cutting point
				Wiring colours may vary.	

Legend

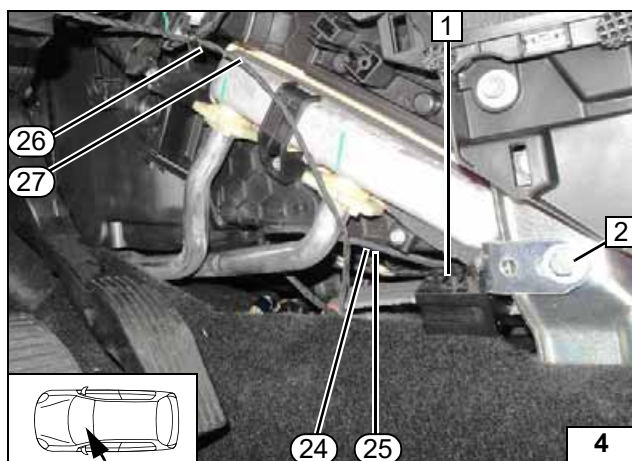

Cold start system installation

Wiring harnesses (24) and (25) as well as temperature sensor (RTD) through cable grommet in the engine compartment, wires (26) and (27) to OBD socket outlet

- 1 CLR module socket
- 2 M6x20 bolt, distance washer (5), original vehicle hole, large diameter washer, flanged nut



Mounting CLR module socket

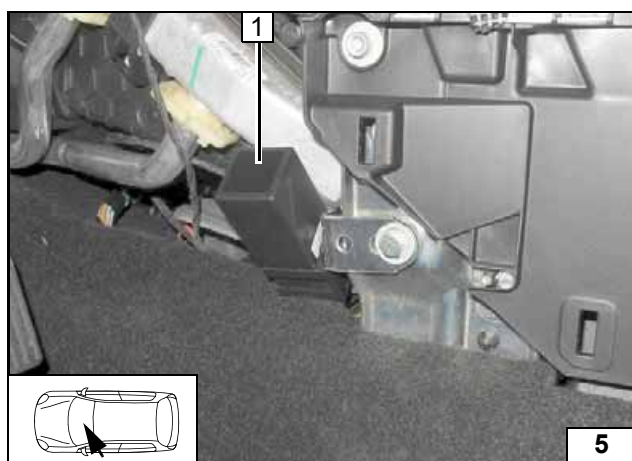

- 1 CLR module

Installing CLR module



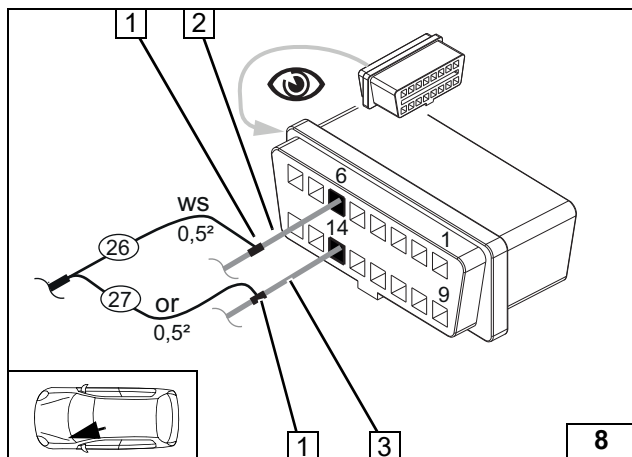

- 1 Crimp and shrink the butt connector [2x]
- 2 Green (gn) wire of OBD socket outlet/ pin 6
- 3 Brown (br) wire of OBD socket outlet/ pin 14
- 26 White (ws) wire of CLR module/ H wiring harness of cold start
- 27 Orange (or) wire of CLR module/ L wiring harness of cold start

**Connecting OBD socket outlet**

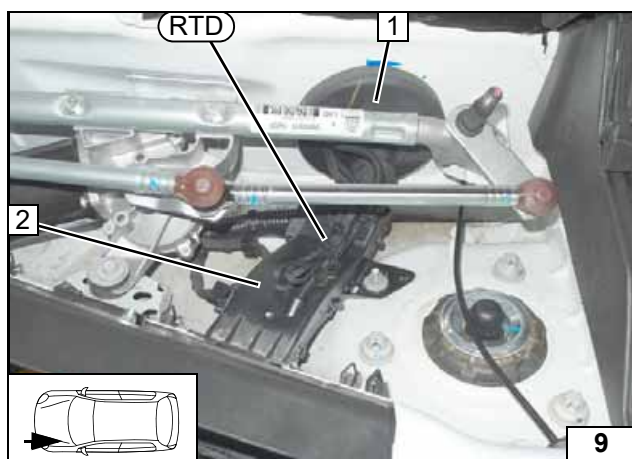

Route wiring harnesses (24) and (25) through the water drain chamber in the engine compartment. Fasten temperature sensor (RTD) with cable tie!



- 1 Cable grommet
- 2 Original vehicle wiring duct

**Routing wires into engine compartment**



Route wiring harnesses (24) and (25) to the right to the engine control unit and secure using cable ties.



**Routing wiring harnesses**

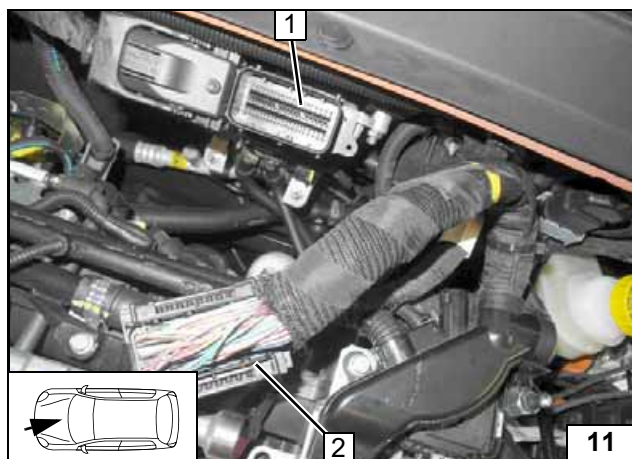

- 1 Socket of engine control unit connector C2
- 2 Connector C2

**Detaching engine control unit connector**

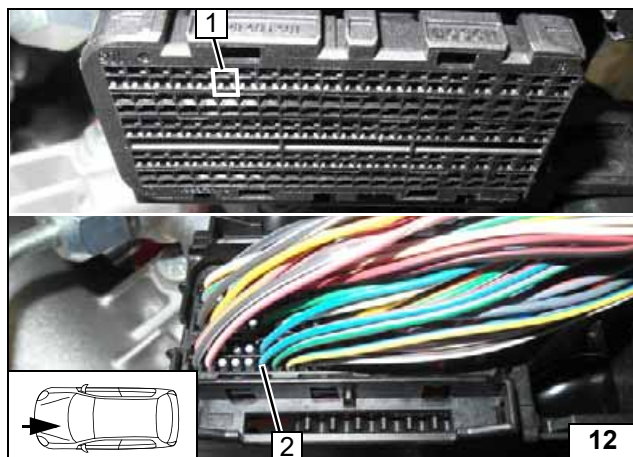
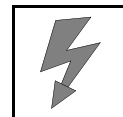

- 1 Blue/red (bl/rt) wire of engine control unit connector C2 pin 100, contact side
- 2 Blue/red (bl/rt) wire of engine control unit connector C2 pin 100, wiring side

View of engine control unit connector C2

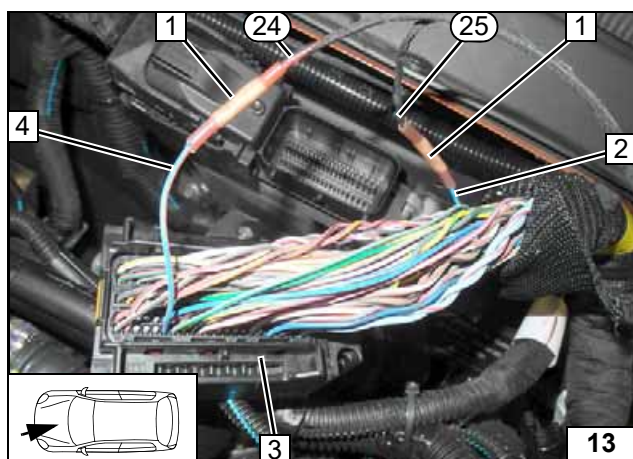

Remove the upper cover of connector C2 and detach a section of the wiring harness wrapping. After finishing this, appropriately wrap and install again.

- 1 Shrink butt connector [2x]
- 2 Blue/red (bl/rt) wire
- 3 Engine control unit connector C2
- 4 Blue/red (bl/rt) wire of engine control unit connector C2 /pin 100
- 24 Red (rt) wire of CLR module/ wiring harness of cold start W
- 25 Black (sw) wire of CLR module/ wiring harness of cold start A

Engine control unit connection

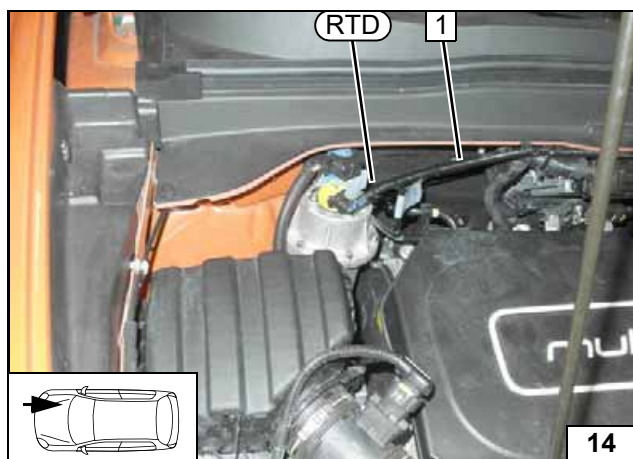

Attach temperature sensor (RTD) to original vehicle wiring harness, in the vicinity of the fuel filter.

- 1 Temperature sensor wiring harness in corrugated tube

Installing temperature sensor



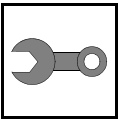

## Final work



### **Warning:**

Final work is not carried out until the installation of the heater in the vehicle has been completed. Check all electrical connections for firm seating. Insulate and tie back loose lines. Spray the heater components with anti-corrosion wax (Tectyl 100K).

