



Water Heater

Thermo Top Evo Parking Heater



Installation Documentation Citroen Berlingo

Validity

Manufacturer	Model	Type	Model year	EG BE No. / ABE
Citroen	Berlingo		From model year 2017	e2 * 2001 / 116 * 0366 * ...

Motorisation	Fuel	Emission standard	Transmission type	Output in kW	Displacement in cm ³	Engine code
1.2B	Petrol	Euro 6	SG	81	1199	HN01

SG = manual transmission

Left-hand drive vehicle

Verified equipment variants: Manual air-conditioning
Halogen main headlights
Front fog lights
LED daytime running lights
Start / Stop

Not verified: Automatic air-conditioning
Passenger compartment monitoring

Total installation time: approx. 8 hours

Citroen Berlingo

Table of Contents

Validity	1	Preparing Installation Location	16
Necessary Components	2	Preparing Heater	18
Installation Instructions	2	Combustion Air	21
Information on Total Installation Time	2	Fuel	22
Information on Operating and Installation Instructions	3	Coolant Circuit	26
Information on Validity	4	Exhaust Gas	31
Technical Information	4	Final Work	35
Explanatory Notes on Document	4	Fuel Standpipe Template	36
Preliminary Work	5	Operating Instructions for Manual Air-Conditioning	37
Heater Installation Location	5		
Preparing Electrical System	6		
Electrical System	8		
Cold Start System Installation	9		
Manual Air-Conditioning Fan Controller	10		
Heater Control Installation	14		
MultiControl CAR Option	14		
Remote Option (Telestart)	14		
ThermoCall Option	15		

Necessary Components

Description	Order No.:
Basic delivery scope of Thermo Top Evo	In accordance with price list
Installation kit Citroen Berlingo 2017 Petrol	1325939A
Heater control as well as indicator lamp for Telestart in consultation with end customer	In accordance with price list

Installation Instructions

Arrange for the vehicle to be delivered with the tank only about ¼ full.

The installation location of the push button in case of Telestart or ThermoCall should be confirmed with the end customer.

Depending on the space required and the vehicle manufacturer's instructions, we recommend the use of a vehicle battery with a higher electrical capacity.

Information on Total Installation Time

The total installation time includes the time needed for mounting and demounting the vehicle-specific components, the heater specific installation time and all other times required for the system integration and initial start-up of the heater.

The total installation time may vary for vehicle equipment other than provided.

Information on Operating and Installation Instructions

1 Important information (not complete)

1.1 Installation and repair



The improper installation or repair of Webasto heating and cooling systems can cause fire or the leakage of deadly carbon monoxide, leading to serious injury or death.



To install and repair Webasto heating and cooling systems you need to have completed a special company training course and have the appropriate technical documentation, special tools and special equipment.



Installation and repair may ONLY be carried out by persons trained and certified in a Webasto training course. NEVER try to install or repair Webasto heating or cooling systems if you have not completed a Webasto training course, you do not have the necessary technical skills and you do not have the technical documentation, tools and equipment available to ensure that you can complete the installation and repair work properly.

Only use genuine Webasto parts. See the Webasto air and water heaters accessories catalogue for this purpose.

1.2 Operation

To ensure safe operation, we recommend having the heater checked every two years by an authorised Webasto dealer, especially when used over a long period and/or under extreme environmental conditions.

Do not operate the heater in closed rooms due to the danger of poisoning and suffocation.

Always switch off the heater before refuelling.

The heater may only be used with the prescribed fuel diesel (DIN EN 590) or petrol (DIN EN 228).

The heater may not be cleaned with a high-pressure cleaner.

1.3 Please note

ALWAYS follow all Webasto installation and operating instructions and observe all warnings.

To become familiar with and understand all functions and properties of the heater, the operating instructions must be read carefully and observed at all times.

For proper, safe installation and repair work, the installation instructions with all warnings and safety information must be carefully read and observed at all times. Please always contact a workshop authorised by Webasto for all installation and repair work.

Important

Webasto shall assume no liability for defects, damage and injuries resulting from a failure to observe the installation, repair and operating instructions of the information contained in them.

This liability exclusion particularly applies to improper installations and repairs, installations and repairs by untrained persons or in the case of a failure to use genuine spare parts.

The liability due to culpable disregard to life, limb or health and due to damage or injuries caused by a wilful or reckless breach of duty remain unaffected, as does the obligatory product liability.

Installation should be carried out according to the general, standard rules of technology. Unless specified otherwise, fasten hoses, lines and wiring harnesses to original vehicle lines and wiring harnesses using cable ties. Insulate loose wire ends and tie back. Connectors on electronic components must audibly snap into place during assembly.

Sharp edges should be fitted with rub protection. Spray unfinished body areas, e.g. drilled holes, with anti-corrosion wax (Tectyl 100K).

Observe the instructions and guidelines of the respective vehicle manufacturer for demounting and mounting vehicle specific components!

The initial start-up is to be executed with the Webasto Thermo Test Diagnosis.

When installing a programmable control module (e.g. a PWM Gateway), the corresponding settings must be checked or adjusted.

2 Statutory regulations governing installation

Guidelines	Thermo Top Evo
Heating Directive ECE R122	E1 00 0258
EMC Directive ECE R10	E1 04 5627

Note

The regulations of these guidelines are binding in the scope of the Directive 70/156/EEC and/or 2007/46/EC (for new vehicle models from 29/04/2009) and should also be observed in countries in which there are no special regulations.

Important

Failure to follow the installation instructions will result in the invalidation of the type approval for the heater and therefore invalidation of the general **homologation of the vehicle**.

Note

The heater is licensed in accordance with paragraph 19, section 3, No. 2b of the StVZO (German Road Traffic Licensing Authority).

2.1 Excerpt from ECE regulation 122 (heating system) paragraph 5 for the installation of the heater

Beginning of excerpt.

ANNEX VII

REQUIREMENTS FOR COMBUSTION HEATERS AND THEIR INSTALLATION

1. GENERAL REQUIREMENTS

1.7.1. A clearly visible tell-tale in the operator's field of view shall inform when the combustion heater is switched on or off.

2. VEHICLE INSTALLATION REQUIREMENTS

2.1. Scope

2.1.1. Subject to paragraph 2.1.2, combustion heaters shall be installed according to the requirements of this Annex.

2.1.2. Vehicles of category O having liquid fuel heaters are deemed to comply with the requirements of this Annex.

2.2. Positioning of heater

2.2.1. Body sections and any other components in the vicinity of the heater must be protected from excessive heat and the possibility of fuel or oil contamination.

2.2.2. The combustion heater shall not constitute a risk of fire, even in the case of overheating. This requirement shall be deemed to be fulfilled if the installation ensures an adequate distance to all parts and suitable ventilation, by the use of fire resistant materials or by the use of heat shields.

2.2.3. In the case of M2 and M3 vehicles, the heater must not be positioned in the passenger compartment. However, an installation in an effectively sealed envelope which also complies with the conditions in paragraph 2.2.2 may be used.

2.2.4. The label referred to in paragraph 1.4 or a duplicate, must be positioned so that it can be easily read when the heater is installed in the vehicle.

2.2.5. Every reasonable precaution should be taken in positioning the heater to minimise the risk of injury and damage to personal property.

2.3. Fuel supply

2.3.1. The fuel filler must not be situated in the passenger compartment and must be provided with an effective cap to prevent fuel spillage.

2.3.2. In the case of liquid fuel heaters, where a supply separate to that of the vehicle is provided, the type of fuel and its filler point must be clearly labelled.

2.3.3. A notice, indicating that the heater must be shut down before refuelling, must be affixed to the fuelling point. In addition a suitable instruction must be included in the manufacturer's operating manual.

2.4. Exhaust system

2.4.1. The exhaust outlet must be located so as to prevent emissions from entering the vehicle through ventilators, heated air inlets or opening windows.

2.5. Combustion air inlet

2.5.1. The air for the combustion chamber of the heater must not be drawn from the passenger compartment of the vehicle.

2.5.2. The air inlet must be so positioned or guarded that blocking by rubbish or luggage is unlikely.

2.6. Heating air inlet

2.6.1. The heating air supply may be fresh or recirculated air and must be drawn from a clean area not likely to be contaminated by exhaust fumes emitted either by the propulsion engine, the combustion heater or any other vehicle source.

2.6.2. The inlet duct must be protected by mesh or other suitable means.

2.7. Heating air outlet

2.7.1. Any ducting used to route the hot air through the vehicle must be so positioned or protected that no injury or damage could be caused if it were to be touched.

2.7.2. The air outlet must be so positioned or guarded that blocking by rubbish or luggage is unlikely.

End of excerpt.

In multilingual versions the German language is binding.

Citroen Berlingo

Information on Validity

This installation documentation applies to Citroen Berlingo Petrol vehicles - for validity, see page 1 - from model year 2017 and later, assuming technical modifications to the vehicle do not affect installation, any liability claims excluded. Depending on the vehicle version and equipment, modifications may be necessary during installation with respect to this 'installation documentation'.

Vehicle and engine types, equipment variants and other specifications not listed in this installation documentation have not been tested. However, installation according to this installation documentation may be possible.

Technical Information

Special Tools

- Hose clamp pliers for auto-tightening hose clamps
- Hose clamp pliers for Clic hose clamps of type W
- Automatic wire stripper 0.2 - 6mm²
- Crimping pliers for cable lug / tab connector 0.5 - 6mm²
- Torque wrench for 2.0 - 10 Nm
- Hose clamping pliers
- Metric thread-setter kit
- Deep-hole marker
- Webasto Thermo Test Diagnosis with current software

Dimensions

- All dimensions are in mm.

Tightening torque values

- Tightening torque values of 5x13 heater bolts and 5x11 heater stud bolts = 8Nm.
- Tightening torque value of 5x15 water connection piece retaining plate bolt = 7Nm.
- Tighten other bolt connections in accordance with manufacturer's instructions or in accordance with state-of-the-art technology.

Explanatory Notes on Document

You will find an identification mark on the outside top right corner of the page in question to provide you with a quick overview of the individual working steps.

Mechanics



Electrics



Coolant Circuit



Combustion Air

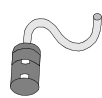

Fuel



Exhaust



Software



Special features are highlighted using the following symbols:

Specific risk of damage to components.



Specific risk due to electrical voltage.



Specific risk of fire or explosion.



Reference to a special technical feature.



The arrow in the vehicle icon indicates the position on the vehicle and the viewing angle.

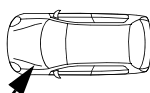

Reference to the manufacturer's vehicle-specific documents.



Reference to specific installation instructions of Webasto components (shown, for example, FuelFix).



Reference to general installation instructions of Webasto components.



Tightening torque according to the manufacturer's vehicle-specific documents.



Preliminary Work

Vehicle



- Open the fuel tank cap.
- Ventilate the fuel tank.
- Close the fuel tank cap again.
- Depressurise the cooling system.
- Disconnect the battery.
- Detach the front section of the left front wheel well trim.
- Completely remove the battery together with the carrier.
- Remove the air intake hose.
- Remove the bracket of the air intake hose.
- Remove the control unit with bracket in the front on the left.
- Remove the rear left wheel and wheel well trim.
- Remove the lower and left instrument panel trim on the driver's side.
- Remove the knee airbag (if present).
- Remove the glove box.
- Remove the footwell trim on the driver's and front passenger's sides.
- Remove the underride protection.

The following work should only be performed during the corresponding installation sequence:



- Lower the fuel tank in accordance with the manufacturer's instructions.

Heater

- Remove years that do not apply from the type and duplicate label.
- Attach the duplicate label (type label) visibly in the appropriate place in the engine compartment.



Heater Installation Location

- 1 Heater



Installation location

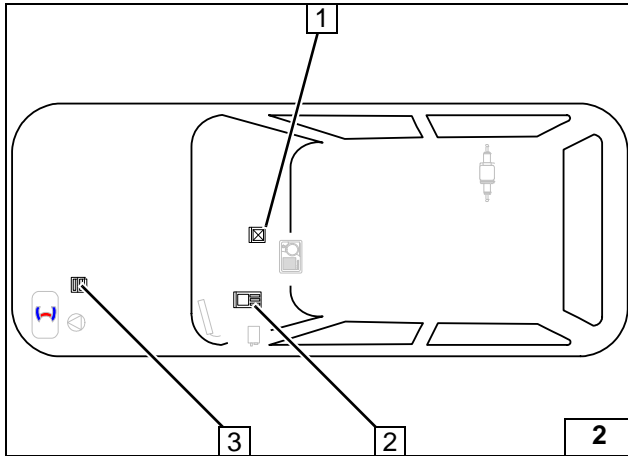

Preparing Electrical System

- 1 Relay K2
- 2 Passenger compartment relay and fuse holder
- 3 Engine compartment fuse holder



Installation overview

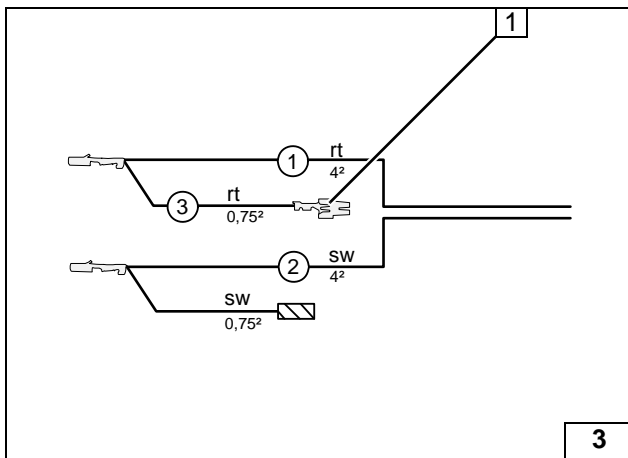

Wire sections retain their numbering in the entire document.

- 1 Power timer
- ① Red (rt) wire of fan wiring harness
- ② Black (sw) wire of fan wiring harness

Preparing / assigning wires

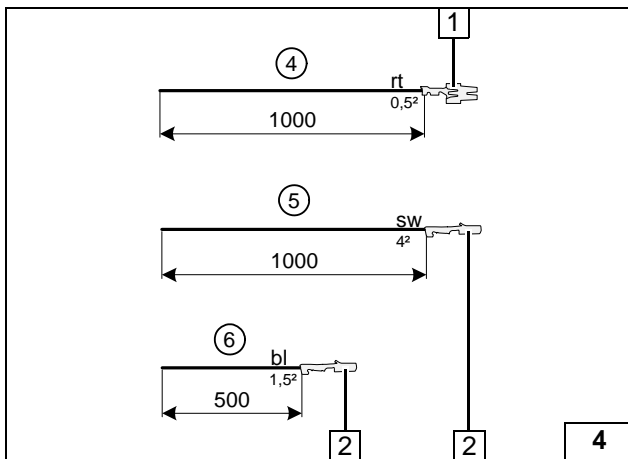

Pull wire section ④ into provided protective sleeving.

- 1 Power timer
- 2 Blade receptacle [2x]

Preparing / assigning wires

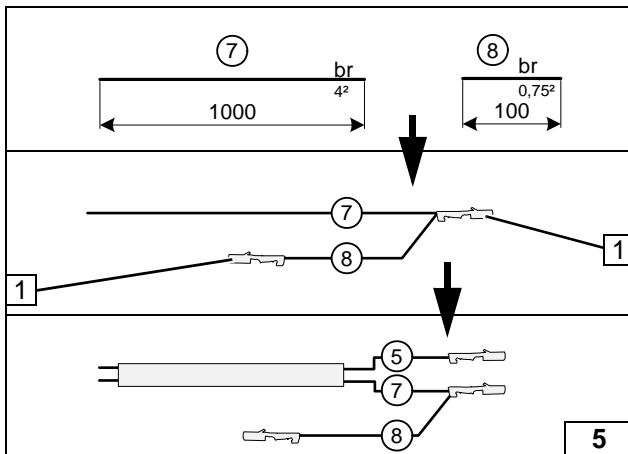

- 1 Blade receptacle [2x]

Preparing / assigning wires

After pre-assembly, draw the wire sections ⑦ and ⑤ (see previous figure) into provided protective sleeving.

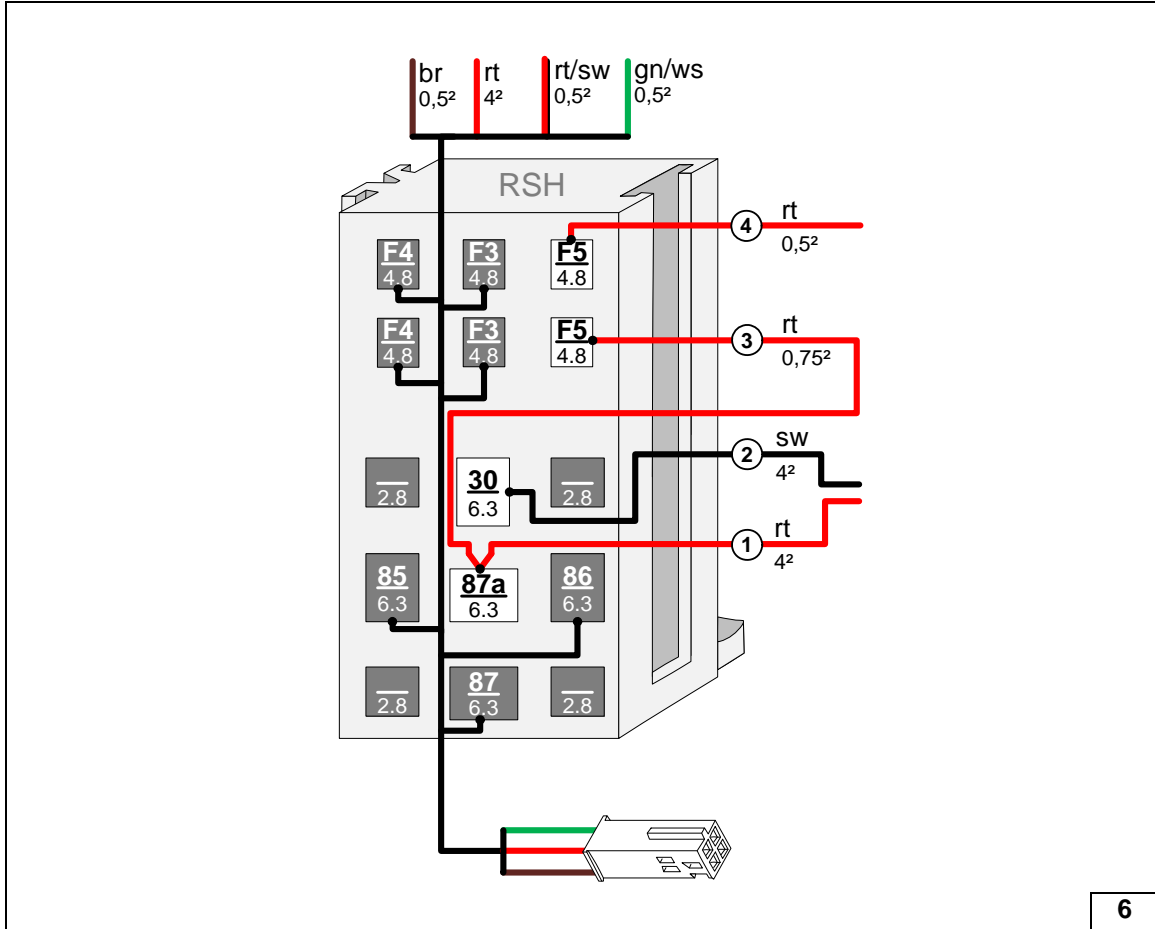

Connecting wires to passenger compartment relay and fuse holder

6

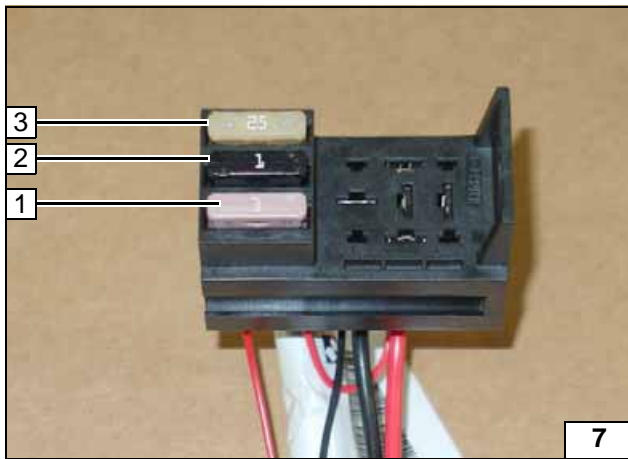

- 1 3A fuse F5
- 2 1A fuse F3
- 3 25A fuse F4

Inserting fuses

7

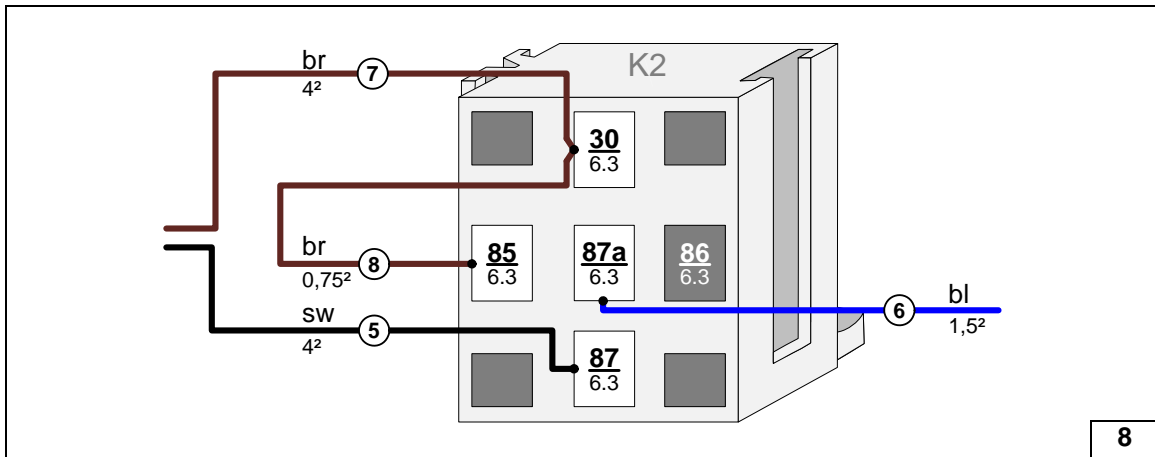

Connecting wires to socket of relay K2

8



Electrical System



Earth wire

- 1 Earth wire on original vehicle earth support point

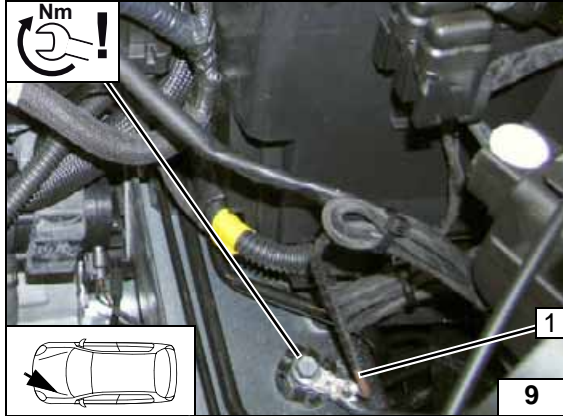

Positive wire

- 1 Positive wire on positive distributor

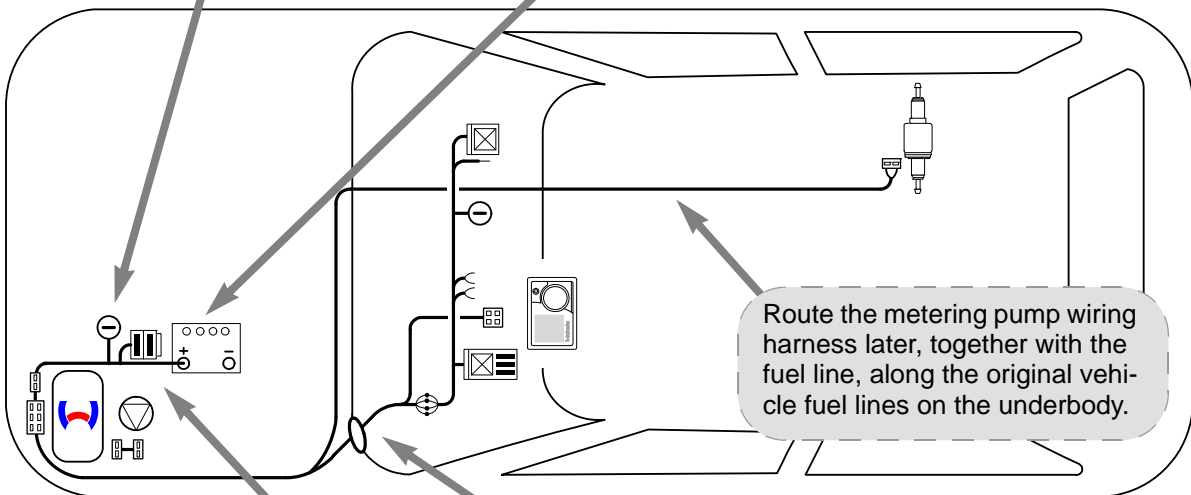
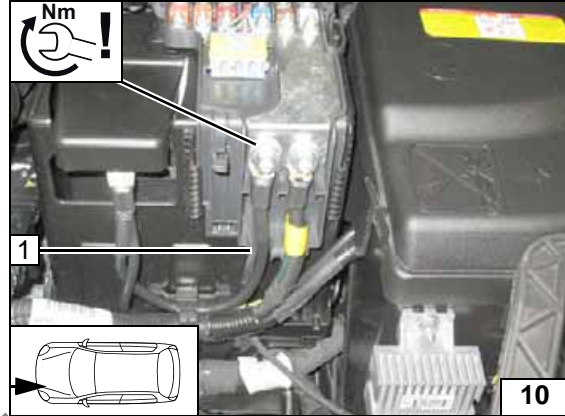

Wiring harness routing diagram

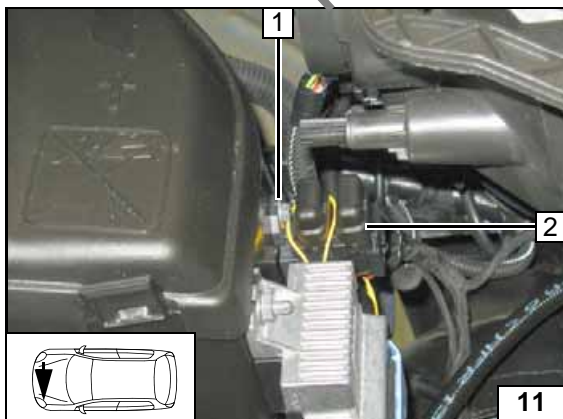

Engine compartment fuse holder

- 1 5.5 mm dia. hole; M5x16 bolt, washer [2x], retaining plate of fuse holder, nut
- 2 Fuses F1-2

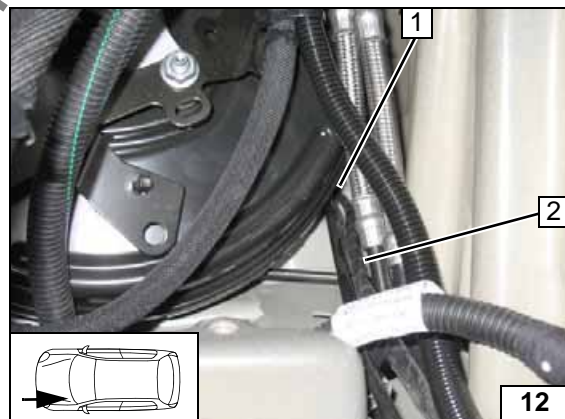

Wiring harness pass through

- 1 Cable grommet of bonnet Bowden cable
- 2 Wiring harnesses of heater, heater controls



Cold Start System Installation

! Integrate the cold start system as per the separate installation documentation:



Cold start system installation documentation for PSA petrol vehicles





Manual Air-Conditioning Fan Controller



System wiring diagram

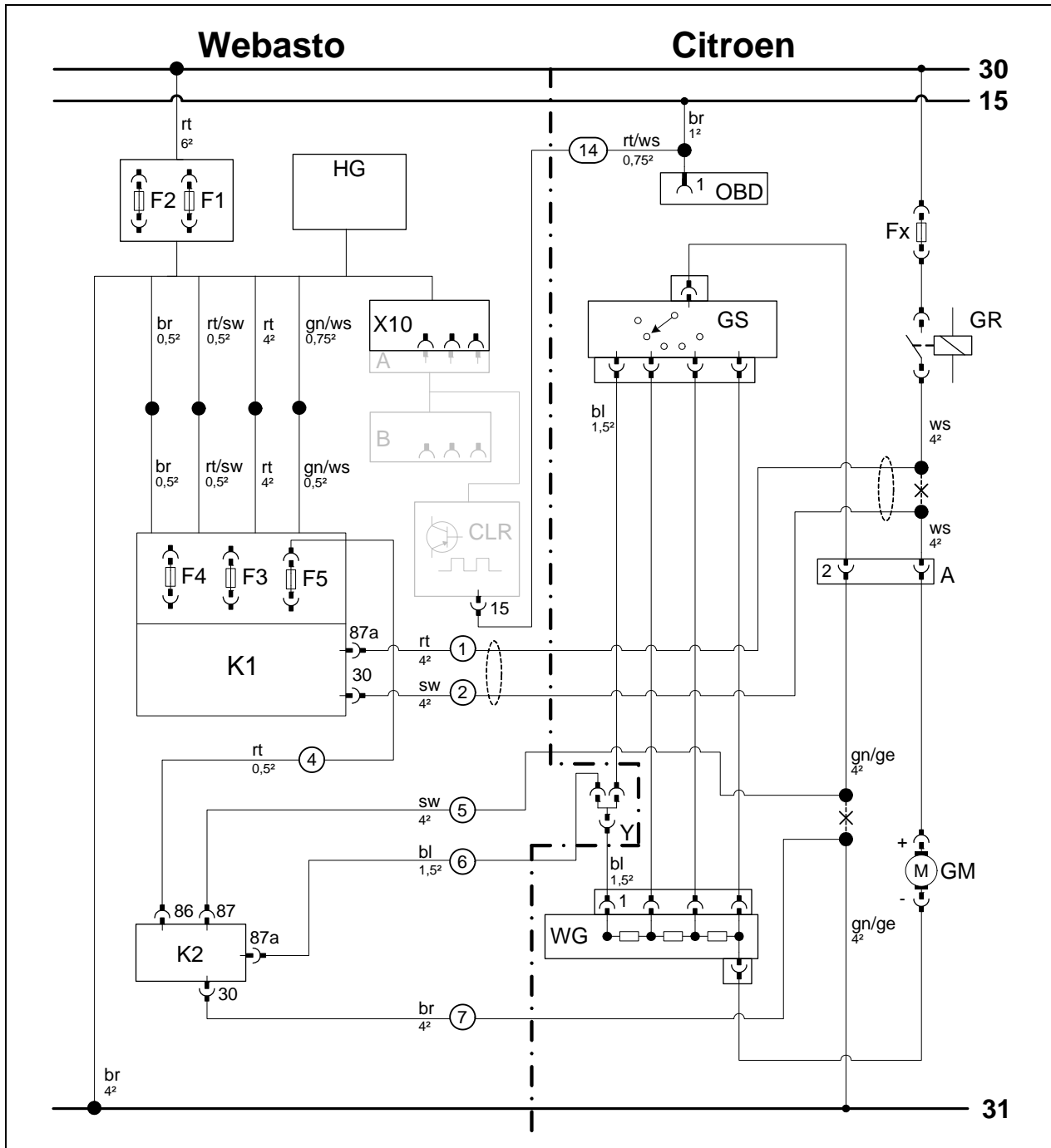



Webasto components		Vehicle components		Colours and symbols	
HG	TT-Evo heater	Fx	Fuse	rt	red
F1	20A fuse	GS	Fan switch	sw	black
F2	30A fuse	GR	Fan relay	ge	yellow
X10	4-pin socket of heater control	A	6-pin connector	gn	green
		GM	Fan motor	bl	blue
A	Connector of CLR module wiring harness	WG	Resistor group	ws	white
		OBD	OBD socket outlet	br	brown
B	Socket of CLR module wiring harness				
CLR	CLR module				
F3	1A fuse				
F4	25A fuse				
F5	3A fuse				
K1	Fan relay				
Y	Y-adapter				
K2	Additional relay			X	Cutting point

Legend

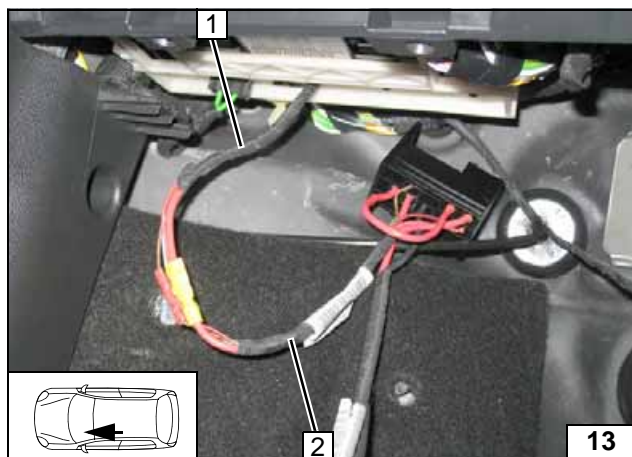

Produce all following electrical connections as shown in the system wiring diagram.

- 1 Heater wiring harness
- 2 Passenger compartment relay and fuse holder wiring harness

Connecting same colour wires of wiring harnesses

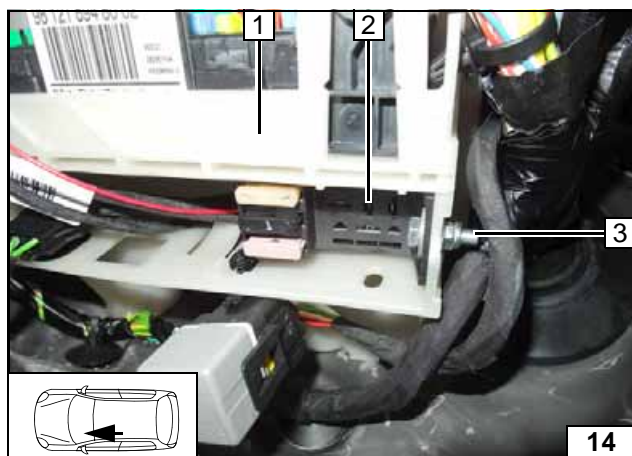

- 1 Fuse and relay box of passenger compartment
- 2 Passenger compartment relay and fuse holder
- 3 M5x16 bolt, large diameter washer [2x], nut, existing hole

Installing passenger compartment relay and fuse holder

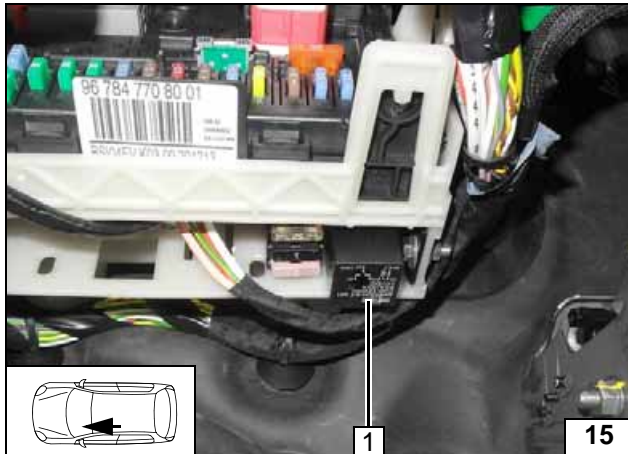
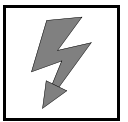

Route red (rt) wire ④ to the front passenger's side.



1 Relay K1

Installing passenger compartment relay and fuse holder

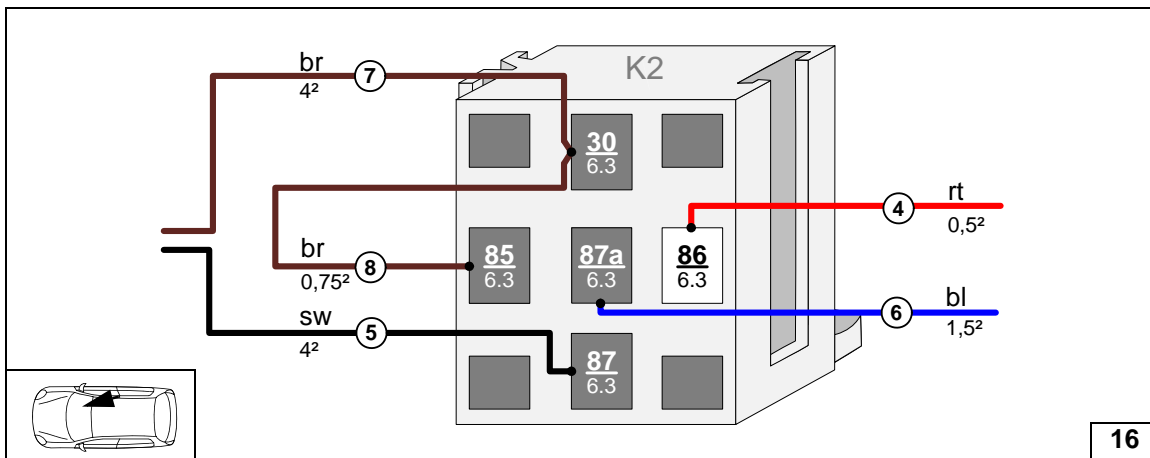

Connecting red (rt) wire ④ to relay K2 socket

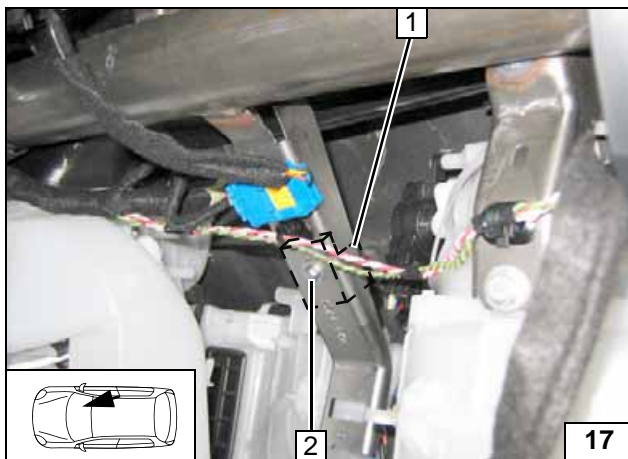

- 1 Socket of relay K2 covered (installed behind original vehicle strut)
- 2 M5x16 bolt, large diameter washer, flanged nut



Insert relay K2 after installation !
Route black (sw) ⑤ and brown (br) wires ⑦ in protective sleeving to the driver's side.

Installing socket of relay K2

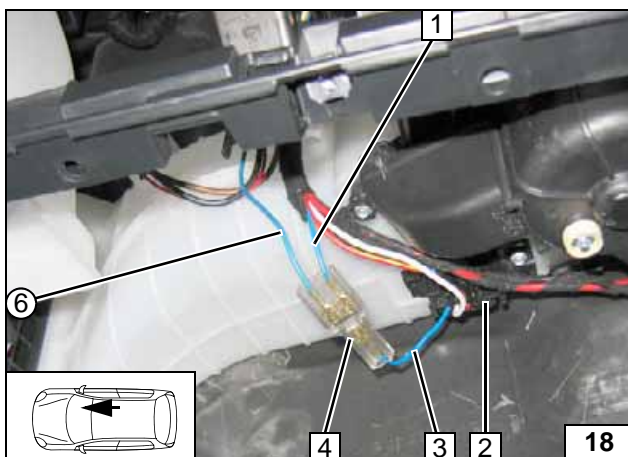

Connection to 5-pin connector 2 from resistor group.



- 1 Blue (bl) wire of fan switch
- 3 Blue (bl) wire of 5-pin connector, pin 1
- 4 Y-adaptor
- ⑥ Blue (bl) wire of K2/87a

Connecting resistor group

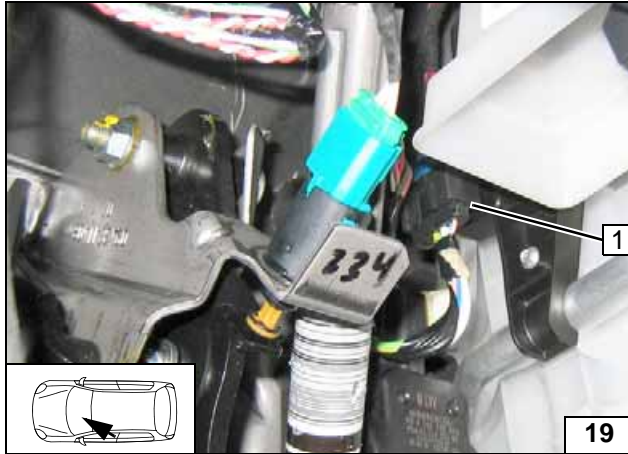
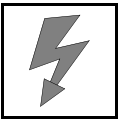

1 6-pin connector A

Discon-
necting
connector
A

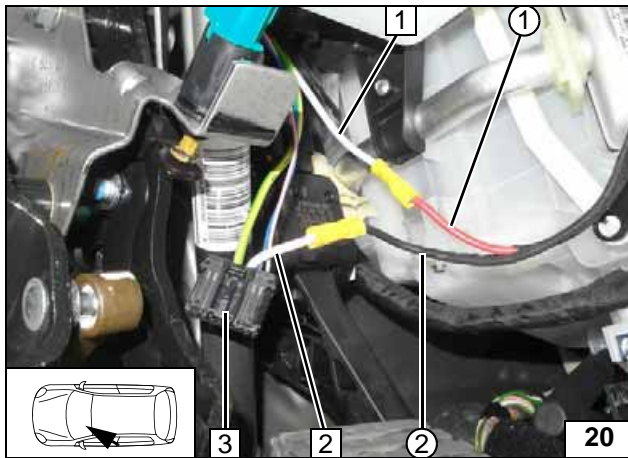

Connection to 6-pin connector A 3.

- 1 White (ws) wire of fan relay
- 2 White (ws) wire 6-pin connector A
- ① Red (rt) wire of K1/87a, fan wiring harness
- ② Black (sw) wire of K1/30, fan wiring harness

Connect-
ing fan mo-
tor

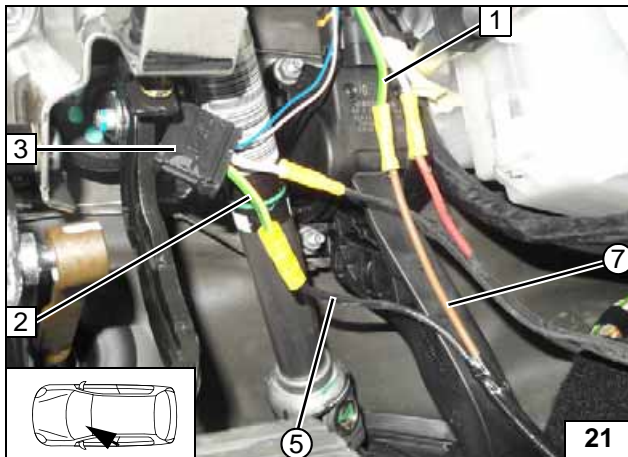

Connection to 6-pin connector A 3.

- 1 Green/yellow (gn/ge) wire of earth wire
- 2 Green/yellow (gn/ge) wire of 6-pin connector A
- ⑤ Black (sw) wire from K2/87
- ⑦ Brown (br) wire from K2/30

Connect-
ing fan
switch

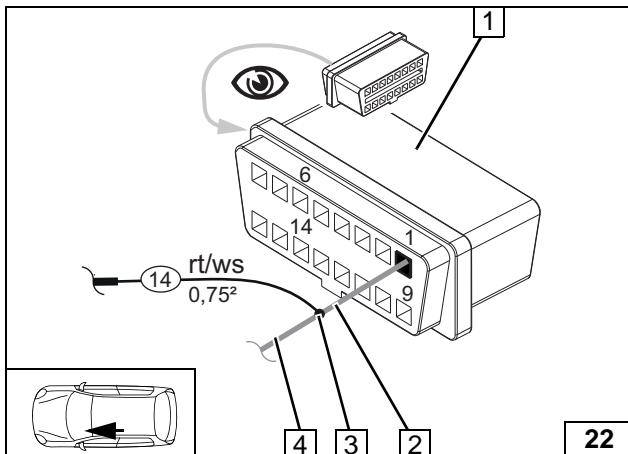

Remove OBD socket outlet from the bracket.

- 1 OBD socket outlet
- 2 Brown (br) wire of OBD socket outlet/ pin 1
- 3 Crimp butt connector
- 4 Brown (br) wire of terminal 15
- ⑭ Red/white (rt/ws) wire of CLR module/ 15 from cold start wiring harness

Connecting
terminal 15

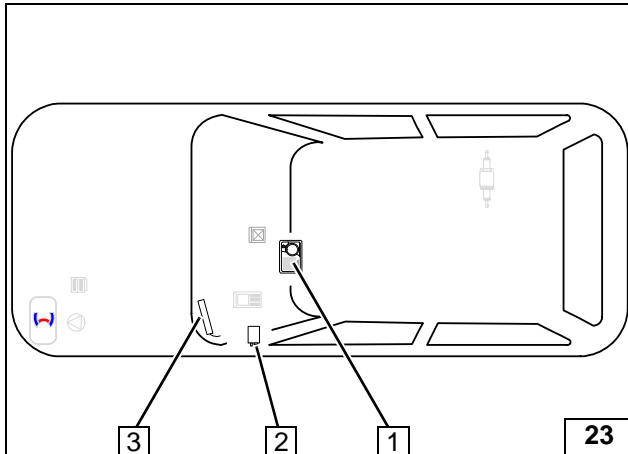
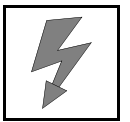

Heater Control Installation

- 1 MultiControl CAR
- 2 Telestart / ThermoCall receiver
- 3 Telestart / ThermoCall aerial



Installation overview

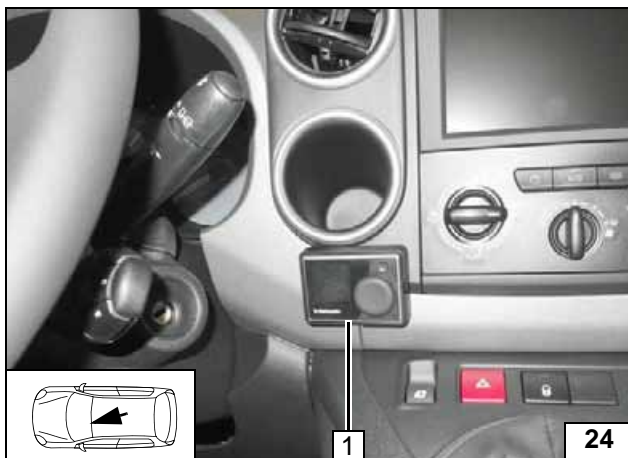

MultiControl CAR Option

- 1 Installation frame



Installing MultiControl CAR



Remote Option (Telestart)

Fasten receiver 1 with double-sided adhesive tape.



Installing receiver

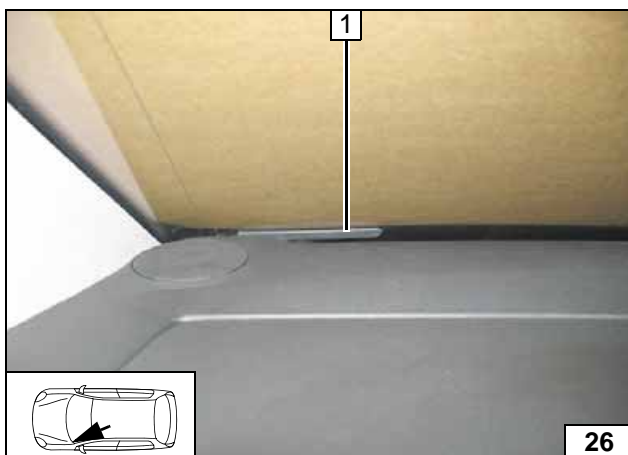

- 1 Aerial

Installing aerial

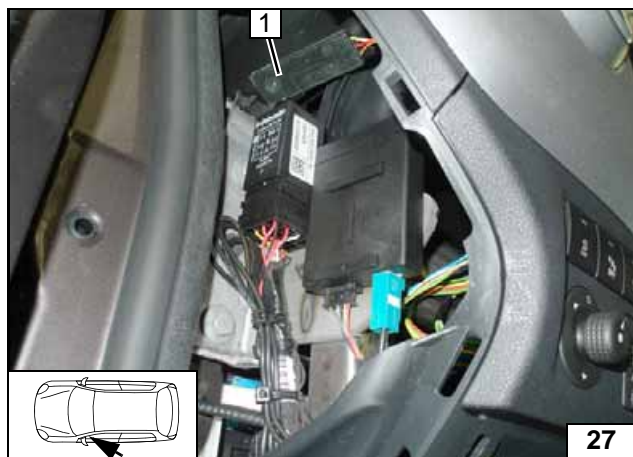

Temperature sensor T100 HTM

Fasten temperature sensor 1 with double-sided adhesive tape.



Installing temperature sensor

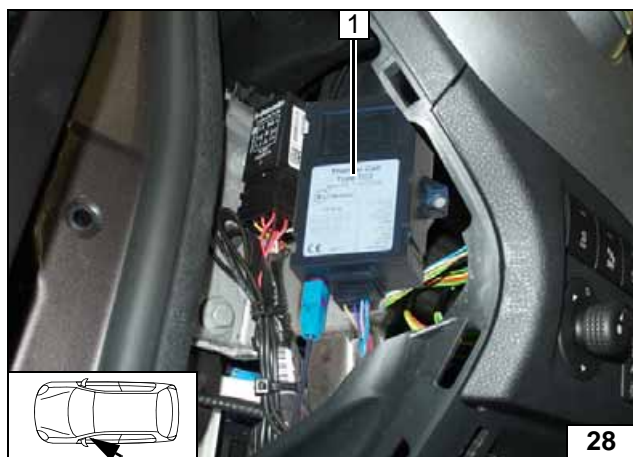

ThermoCall Option

Fasten receiver 1 with double-sided adhesive tape.



Installing receiver

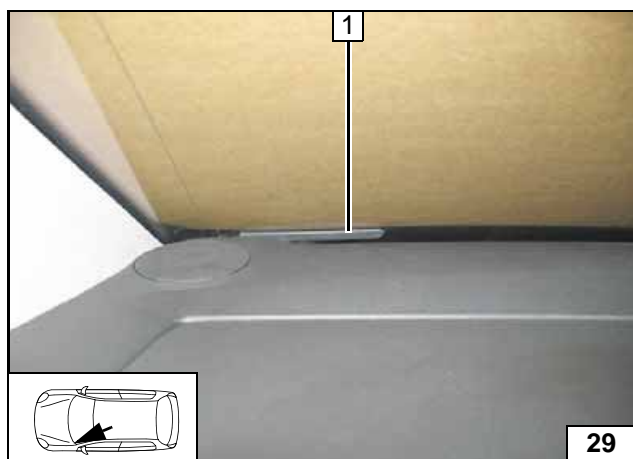

1 Aerial (optional)

Installing aerial

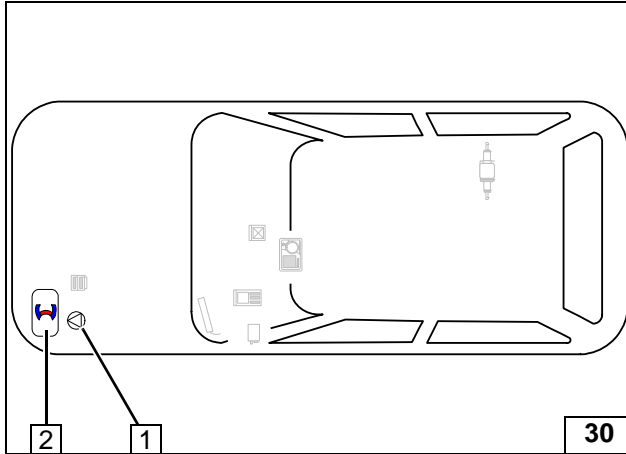
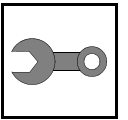

Preparing Installation Location

- 1 Circulating pump
- 2 Heater



Installation overview

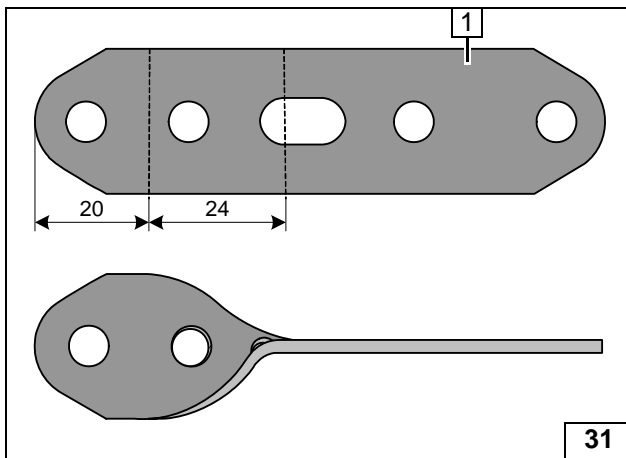

- 1 Twist perforated bracket in longitudinal axis

Preparing perforated bracket

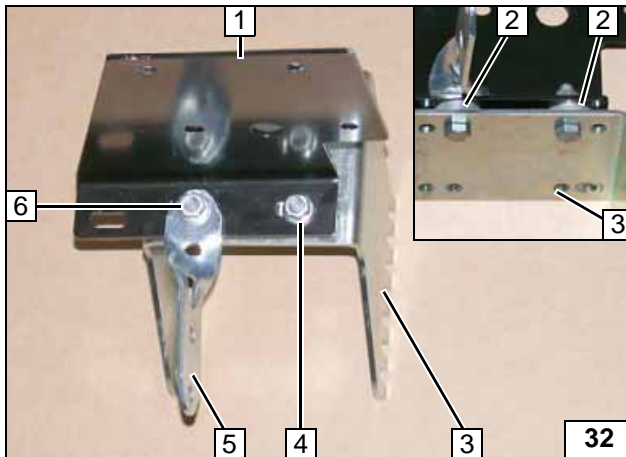

Install retaining plate 1 and bracket 3.

- 2 5 mm shim
- 4 M6x16 bolt, 5 mm shim, flanged nut
- 5 Perforated bracket
- 6 M6x20 bolt, 5 mm shim, flanged nut



Premounting bracket

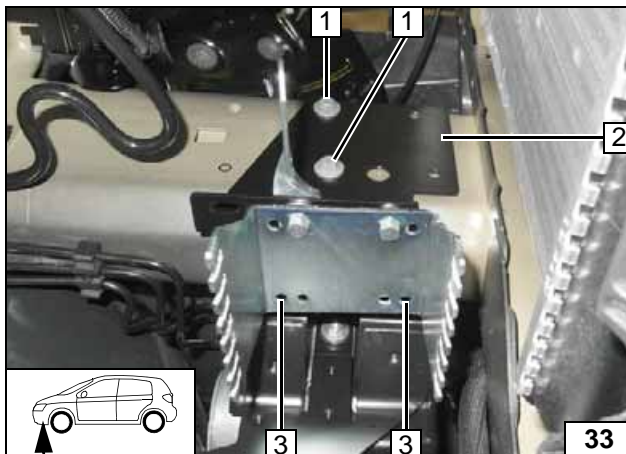

Remove original vehicle relay.
Install retaining plate with bracket 2 loosely.

- 1 Original vehicle bolt in existing hole [2x]
- 3 Copy hole pattern [2x]



Copying hole pattern

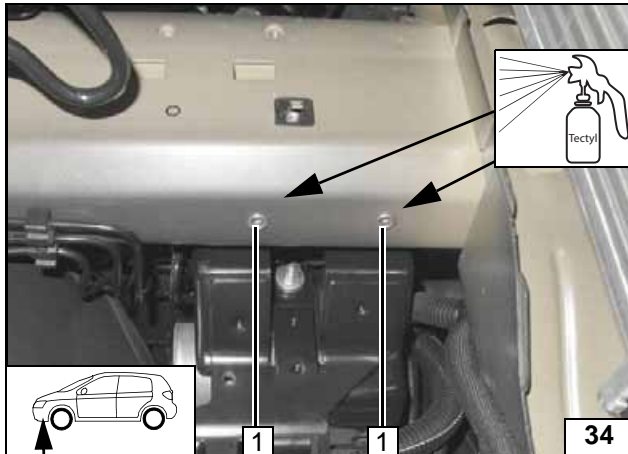
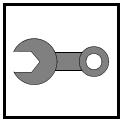

Remove retaining plate with bracket again.

- 1 9.1mm dia. hole; rivet nut [2x each]



Hole in frame side member / installing rivet nut

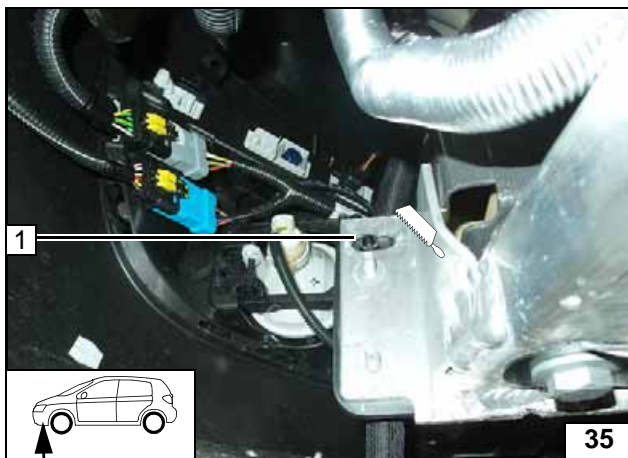

Cut off connection piece 1 flush with the frame level as shown.



Shortening connection piece

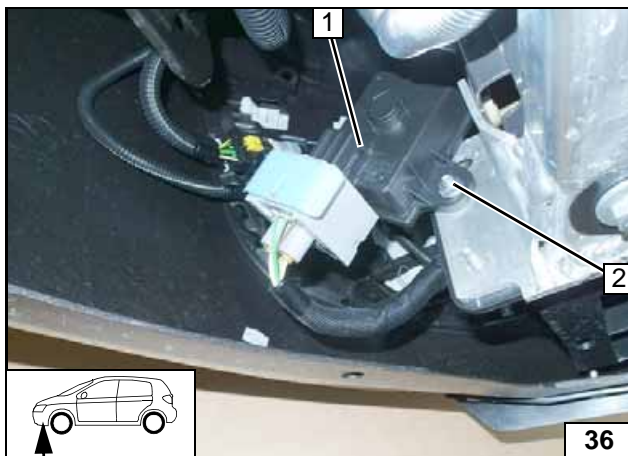

- 1 Original vehicle relay
- 2 Original vehicle stud bolt, flanged nut

Installing original vehicle relay

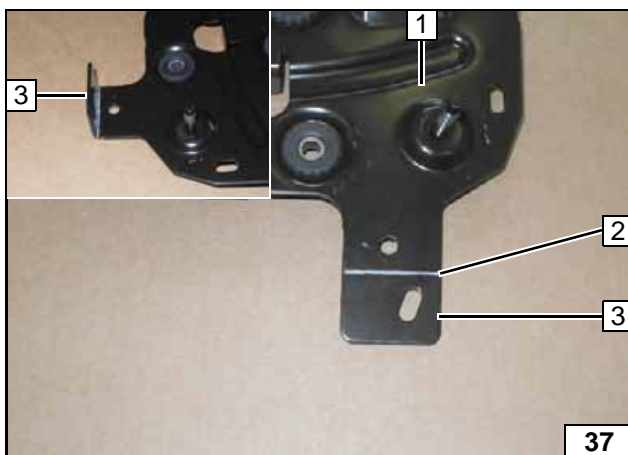

Bend tab 3 of original vehicle bracket 1 by 90° upwards at bending line 2 .



Preparing original vehicle bracket

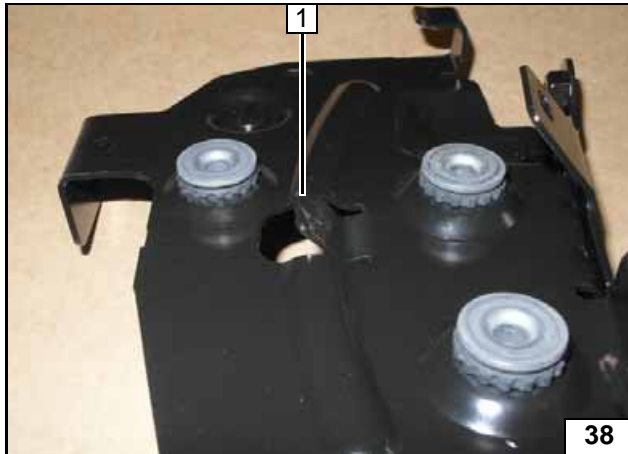
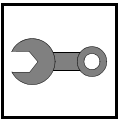

Bend tab 1 as shown.



Preparing original vehicle bracket

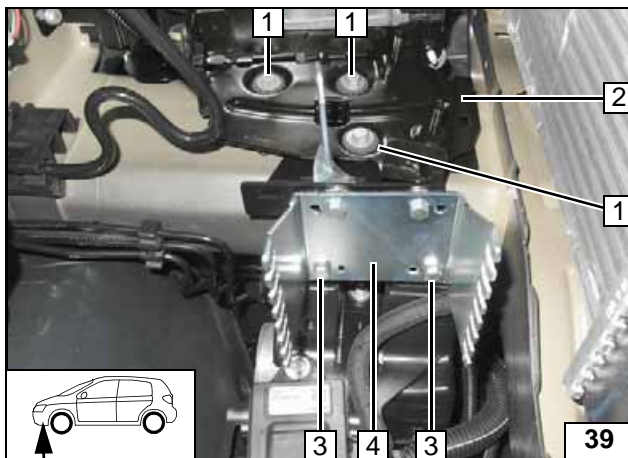

- 1 Original vehicle bolts [3x]
- 2 Original vehicle bracket
- 3 M6x35 bolt, spring lockwasher, 20mm shim [2x each]
- 4 Bracket

Installing bracket

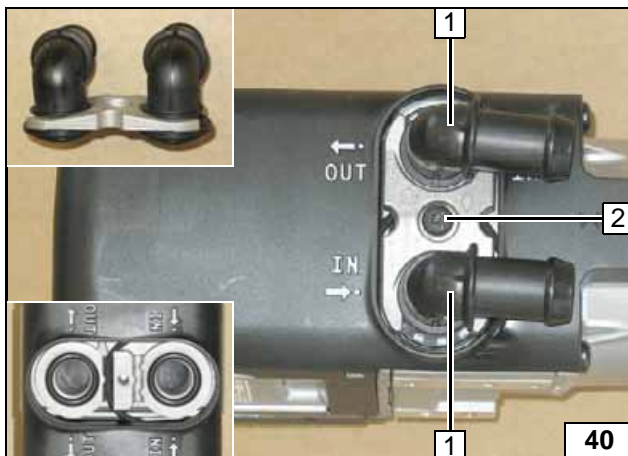

Preparing Heater

All vehicles

- 1 Water connection piece, sealing ring [2x each]
- 2 5x15 self-tapping bolt, retaining plate of water connection piece



Installing water connection piece

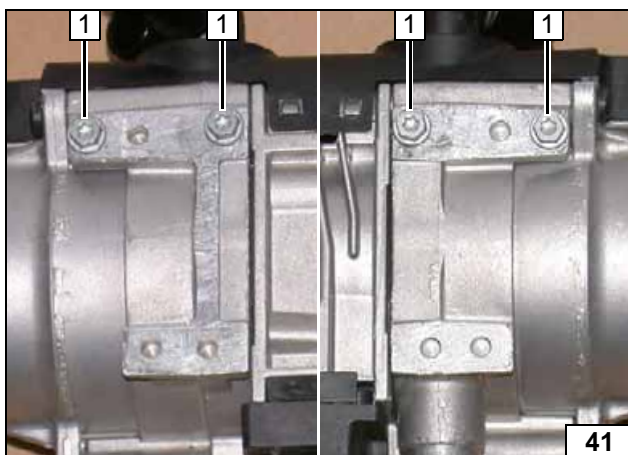

Screw 5x13 self-tapping bolts 1 [4x] into existing holes by a maximum of 3 thread turns.



Premounting bolts loosely

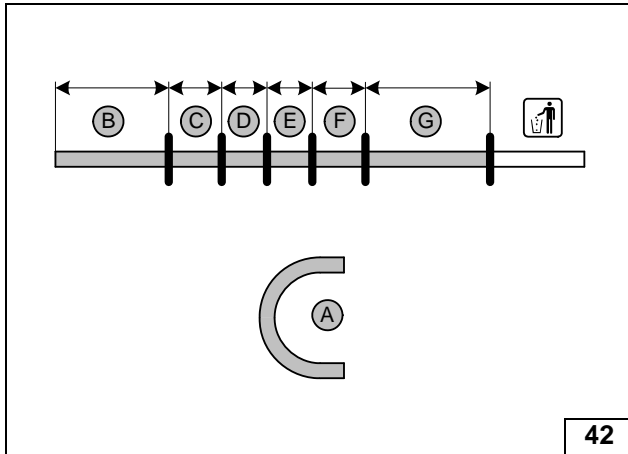
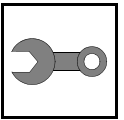

- A = 180°, 18mm dia.
- B = 440
- C = 60
- D = 60
- E = 60
- F = 100
- G = 650



Cutting hoses to length

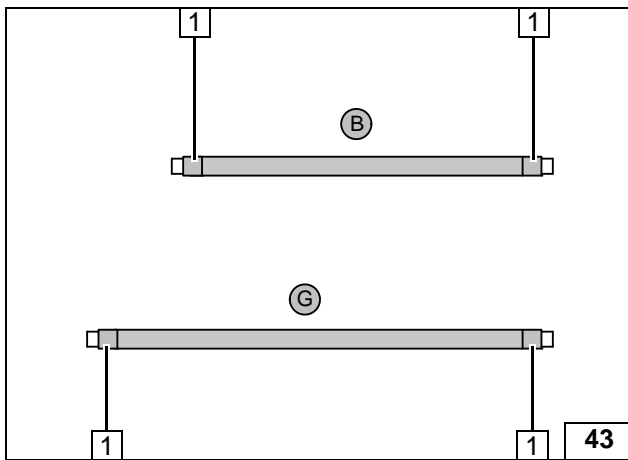

Push braided protection hoses onto hose **B** and **G** and cut to length.
Cut heat shrink plastic tubing to size.



- 1 50 mm long heat shrink plastic tubing [4x]

Preparing hoses

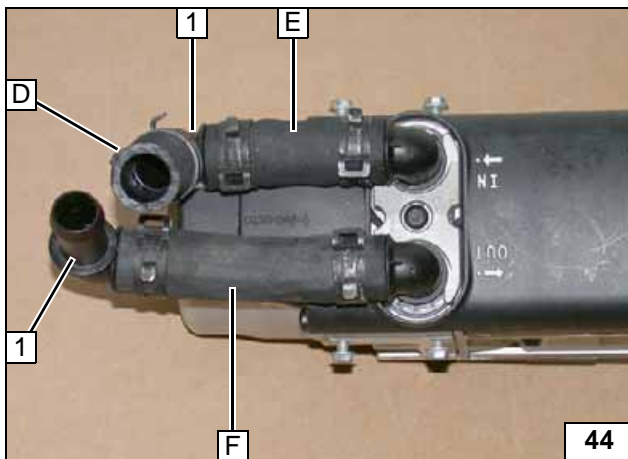

All spring clips = 25mm dia.!

- 1 90°, 18x18 connecting pipe

Premounting hoses

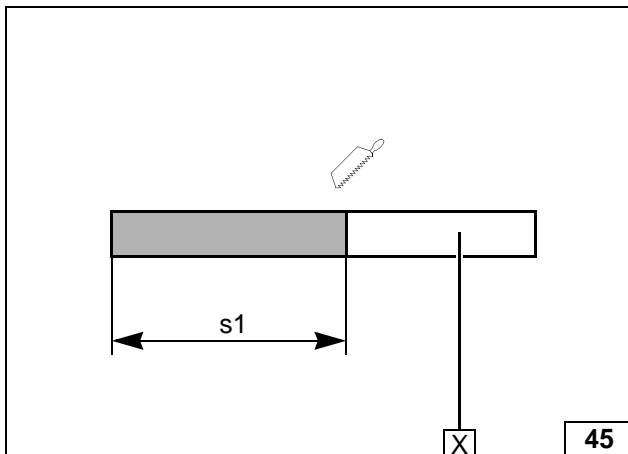

s1 = 260

X =

Cutting combustion air pipe s1 to length

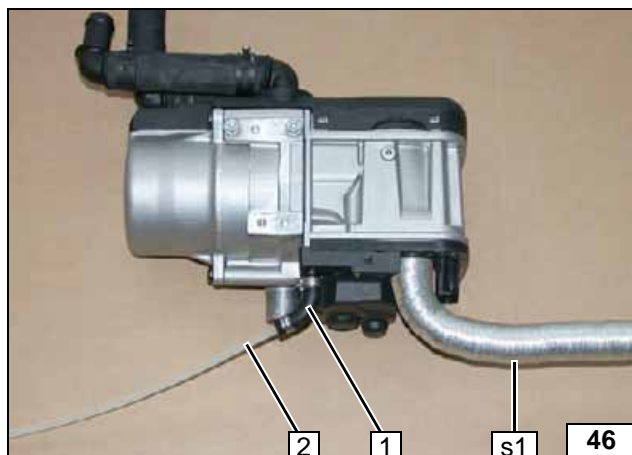

- 1 90° moulded hose, 10mm dia. clamp [2x]
- 2 Fuel line



Premounting heater

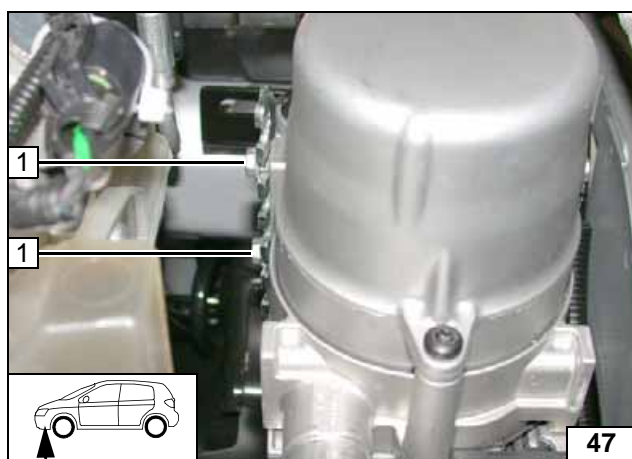

- 1 Tighten 5x13 self-tapping bolt [2x]

Installing heater

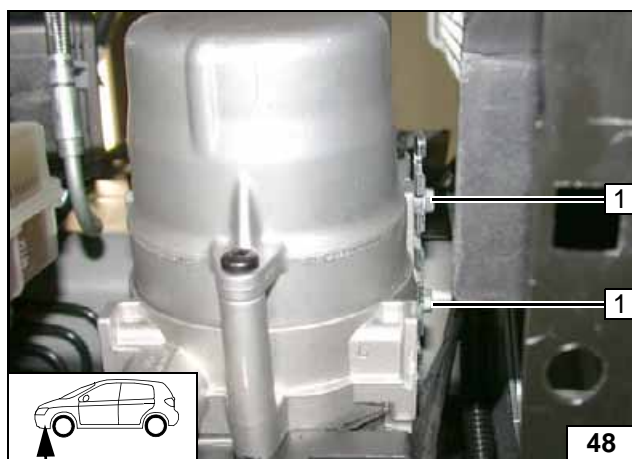

- 1 Tighten 5x13 self-tapping bolt [2x]

Installing heater

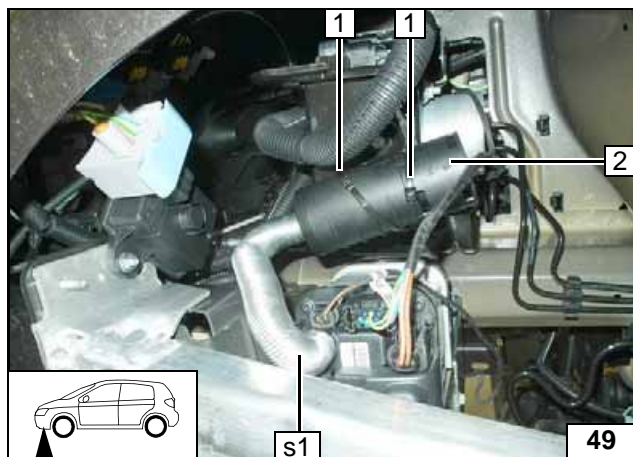
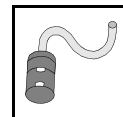

Combustion Air

- 1 Cable tie [2x]
- 2 Silencer



Installing silencer

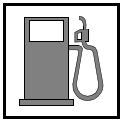

Fuel



Open the vehicle's fuel tank cap, ventilate the tank and then re-close the tank lock.

Catch any fuel running off in an appropriate container.

Route fuel line and metering pump wiring harness so that they are protected against stone impact. Unless specified otherwise, always fasten using cable ties.



Provide rub protection for fuel line and wiring harness in areas where there are sharp edges.

The fuel line and wiring harness are routed to the metering pump as shown in the wiring harness routing diagram.

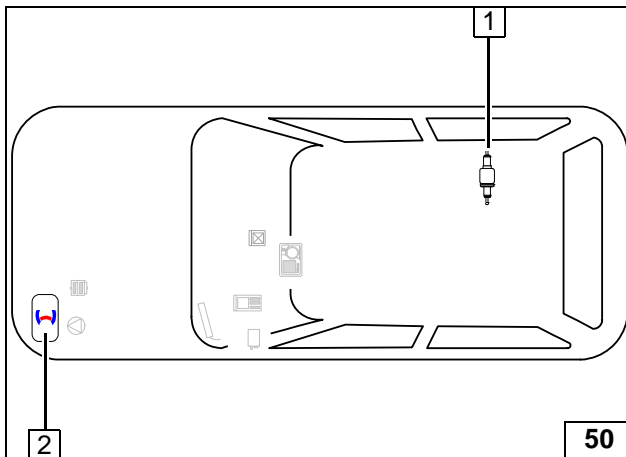

- 1 Metering pump
- 2 Heater

Installation overview

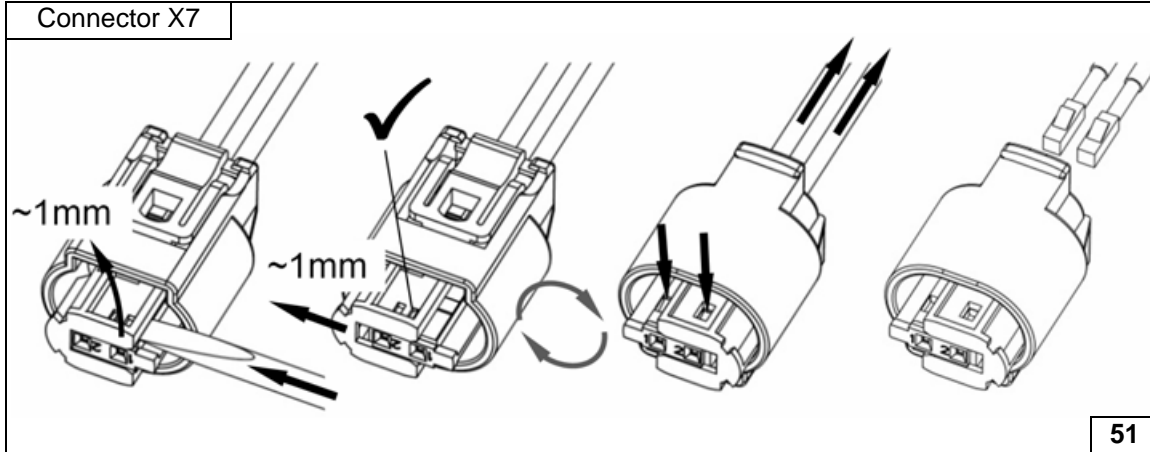

Dismantling metering pump connector

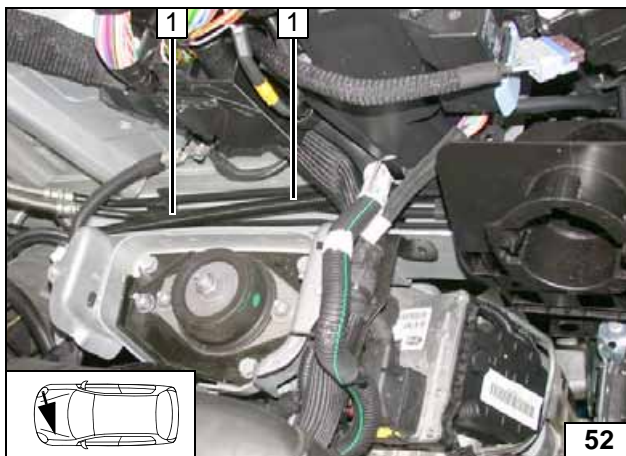

Route fuel line and wiring harness of metering pump into 2100mm corrugated tube 1 to the firewall.



Routing lines

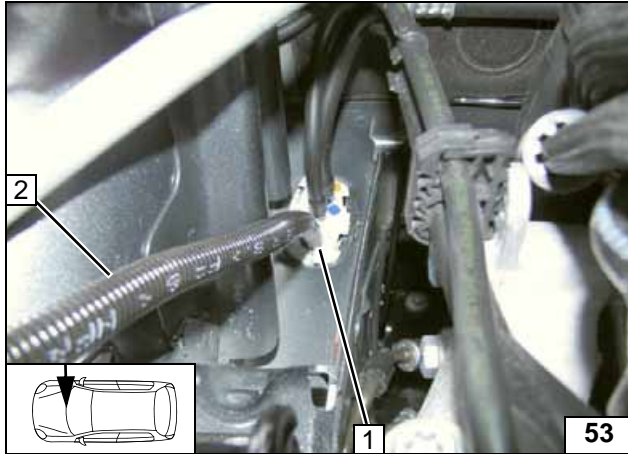
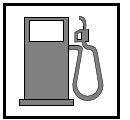

Route fuel line and wiring harness of metering pump in original vehicle line duct to the underbody.



- 1 Original vehicle pass through
- 2 Fuel line, metering pump wiring harness in corrugated tube

Routing lines

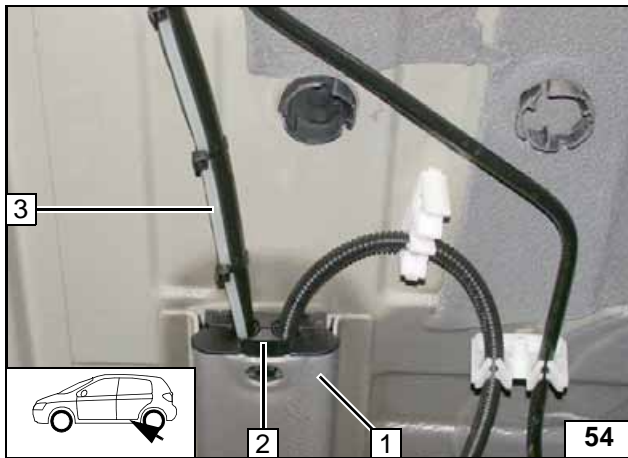

- 1 Original vehicle line duct
- 2 Original vehicle sealing
- 3 Fuel line, metering pump wiring harness

Routing lines

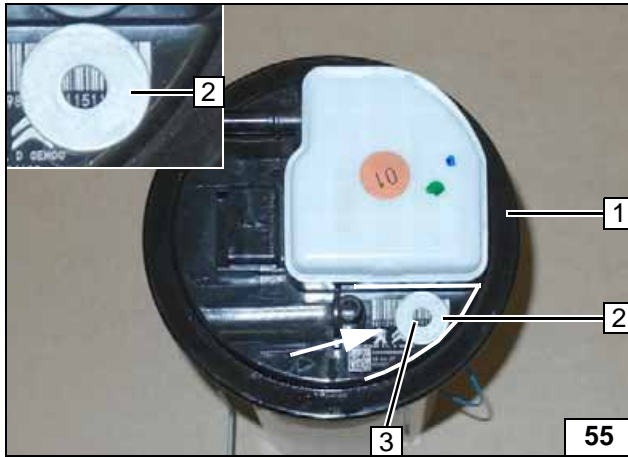

Lower the fuel tank in accordance with the manufacturer's instructions. Disconnect and remove fuel tank sending unit 1.



- 2 Position washer with outer dia. $d_a = 21.6\text{mm}$ as shown, will be used as a template
- 3 Copy hole pattern

Fuel extraction

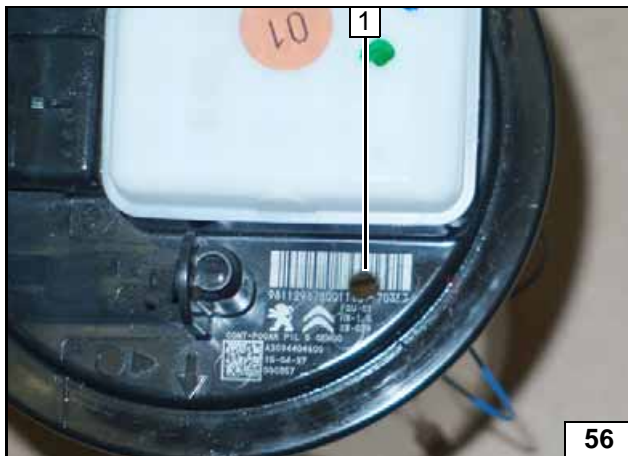

- 1 6 mm dia. hole



Hole in fuel tank sending unit

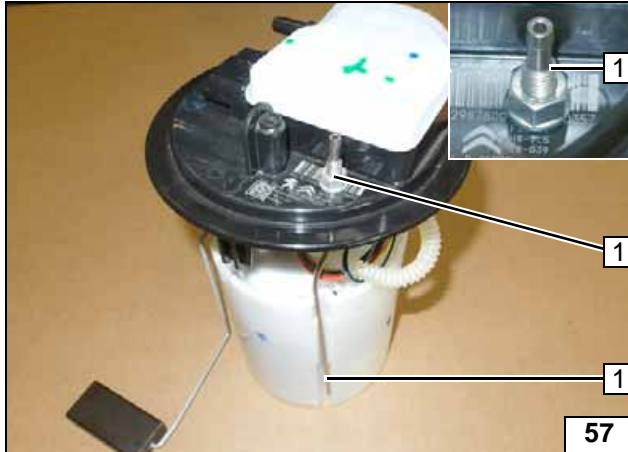

Bend fuel standpipe 1 according to template and cut to length.



Installing fuel standpipe

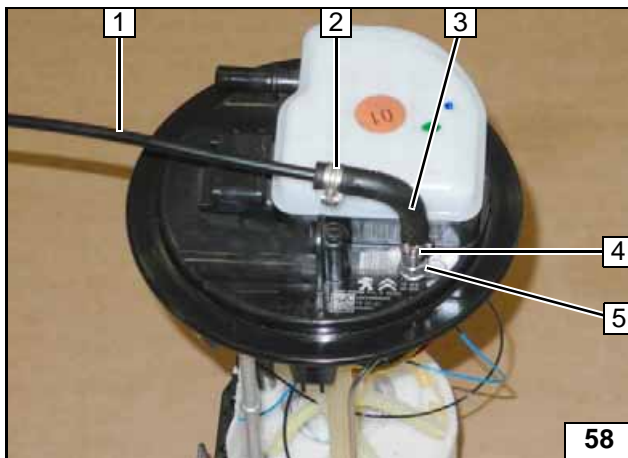

- 1 1500mm long fuel line of fuel standpipe
- 2 10 mm dia. clamp
- 3 3.5x4.5mm dia. moulded hose
- 4 9 mm dia. clamp
- 5 Fuel standpipe

Connecting fuel line

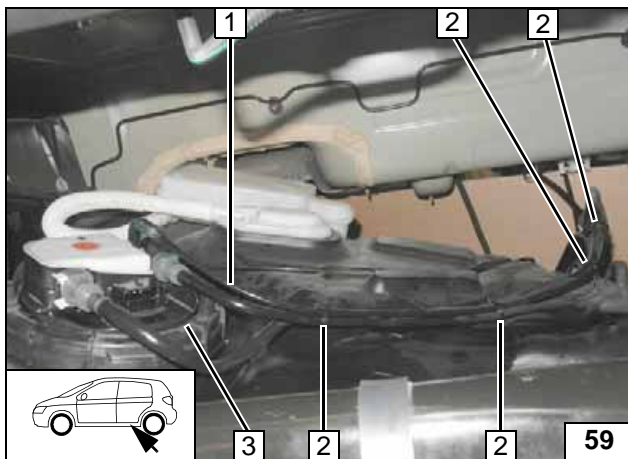

Install fuel tank sending unit 3 in accordance with manufacturer's instructions. Route fuel line of fuel standpipe 1 along original vehicle fuel lines and secure using cable ties 2 [4x]. Install fuel tank in accordance with manufacturer's instructions.



Routing fuel line

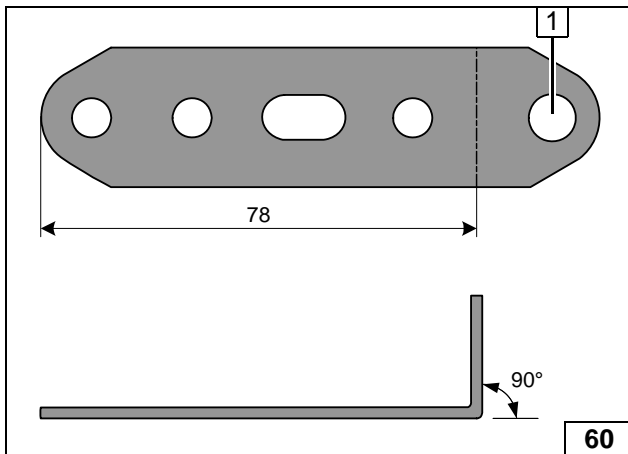

- 1 Drill out hole to 9 mm dia.

Preparing perforated bracket

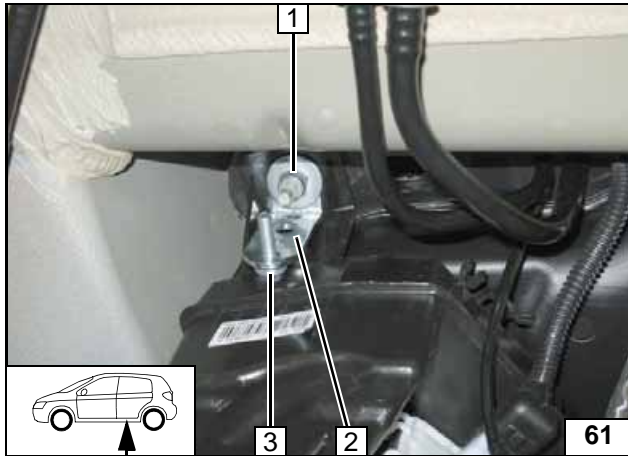

- 1 Original vehicle bolt
- 2 Perforated bracket
- 3 Mount M6x25 bolt

Installing perforated bracket

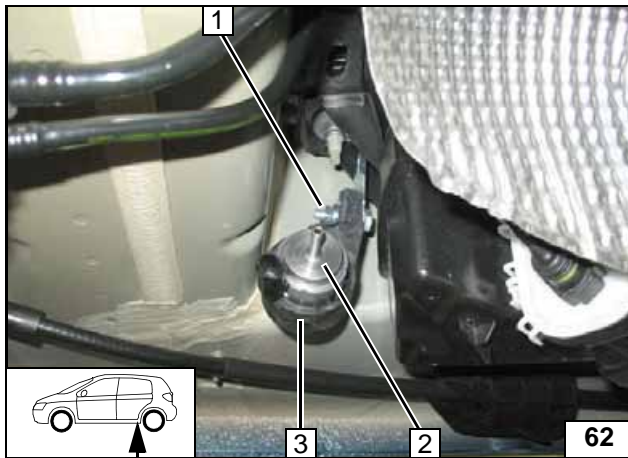

- 1 Flanged nut, support angle bracket
- 2 Metering pump
- 3 Metering pump mount



Installing metering pump

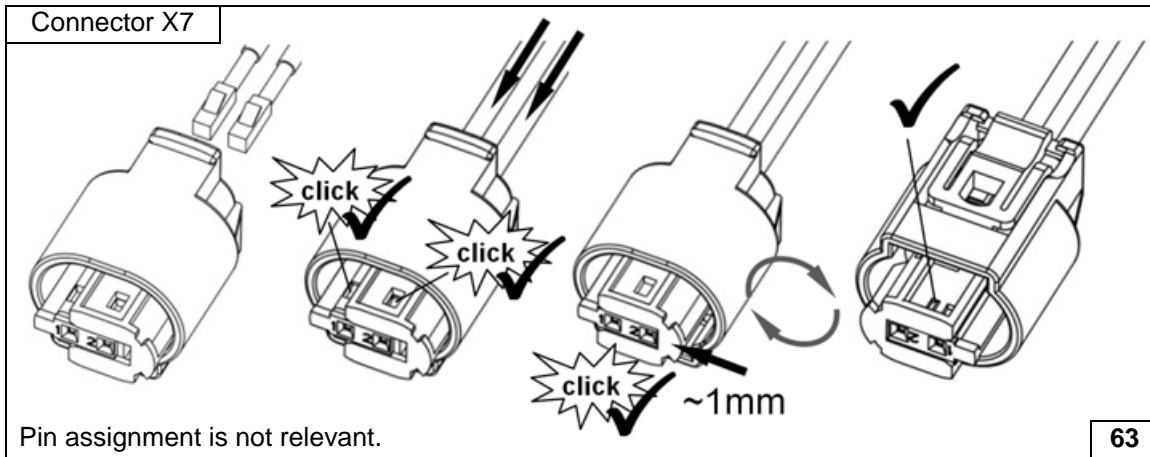

Pin assignment is not relevant.

Completing metering pump connector

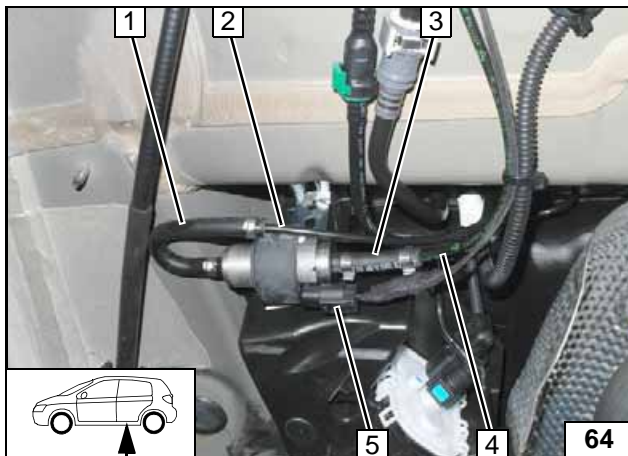

Check the position of the components; adjust if necessary. Check that they have freedom of movement.

- 1 180° moulded hose, 10mm dia. clamp [2x]
- 2 Fuel line of fuel standpipe
- 3 Hose section, 10mm dia. clamp [2x]
- 4 Fuel line of heater
- 5 Metering pump wiring harness, connector X7 mounted



Connecting metering pump

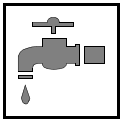

Coolant Circuit







Any coolant running off should be collected in an appropriate container. Route hoses kink-free. Unless specified otherwise, always fasten using cable ties. Position clamps so that other hoses cannot be damaged. The heater must be filled with coolant when installing the hoses.

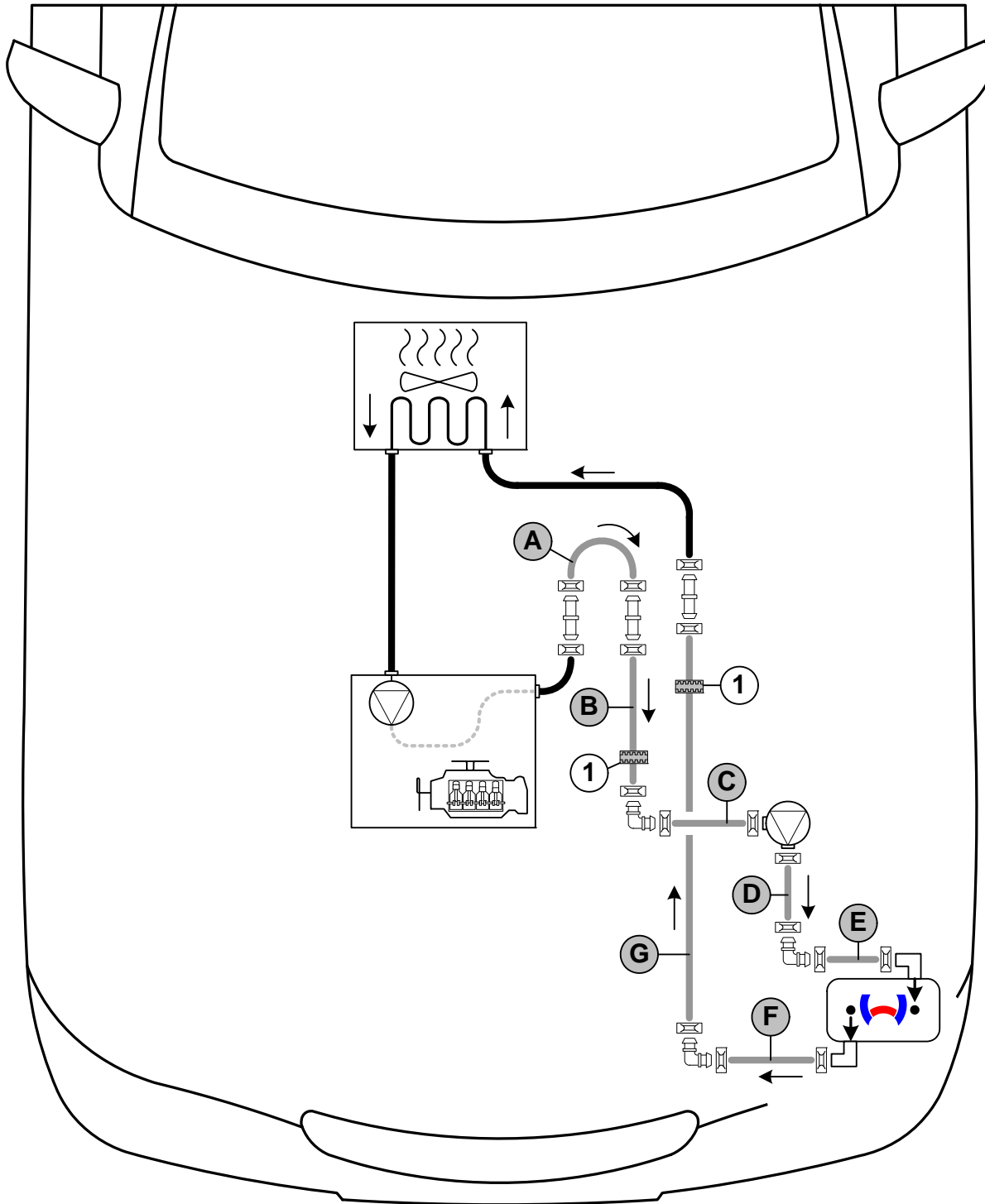

The connection should be modelled on an 'inline' circuit and based on the following diagram:



Hose routing diagram

All spring clips  = 25 mm dia. All connecting pipes  and  = 18x18 mm dia.
 1 = Black (sw) rubber isolator .



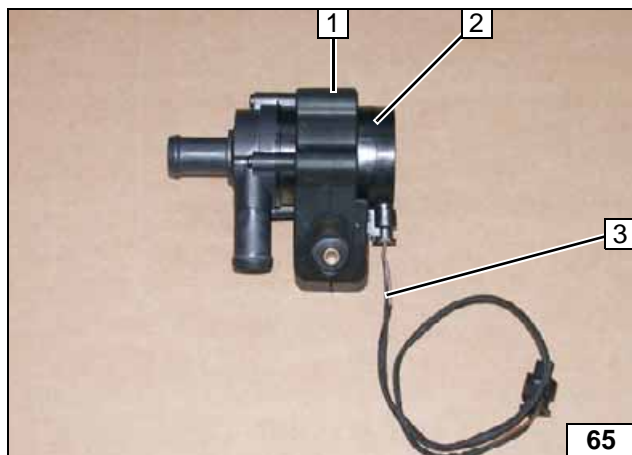

- 1 Circulating pump mount
- 2 Circulating pump
- 3 Circulating pump wiring harness

Premounting circulating pump

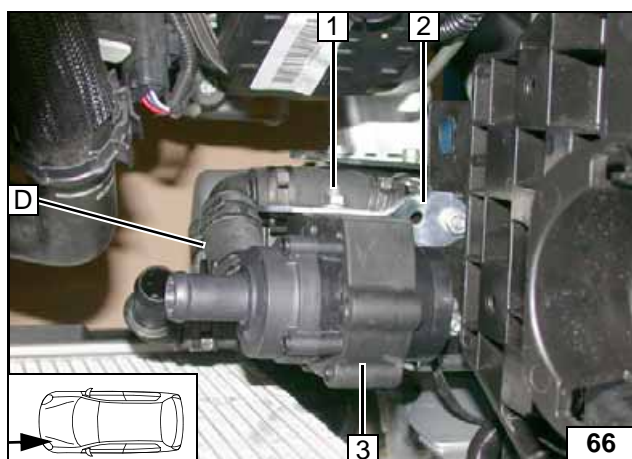

- 1 M6x25 bolt, flanged nut
- 2 Perforated bracket
- 3 Circulating pump mount

Installing circulating pump

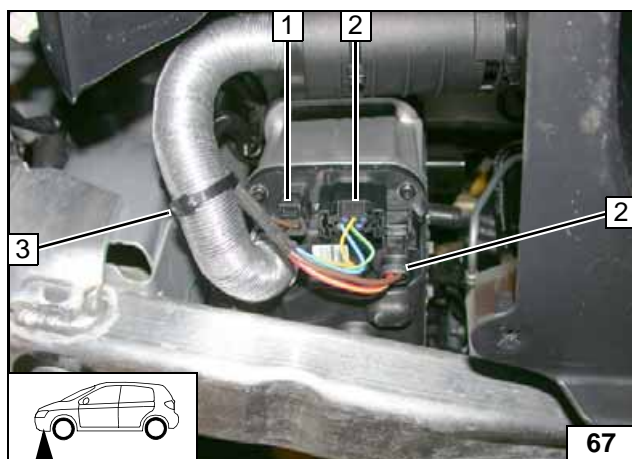

- 1 Connector of circulating pump wiring harness
- 2 Heater wiring harness connector [2x]
- 3 Cable tie

Installing wiring harnesses

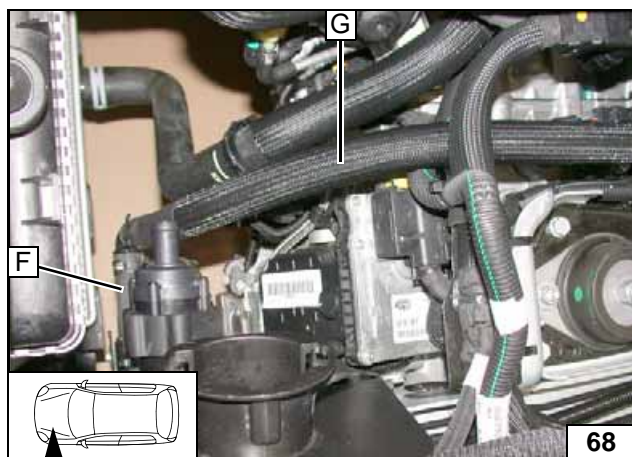

Connecting heater outlet

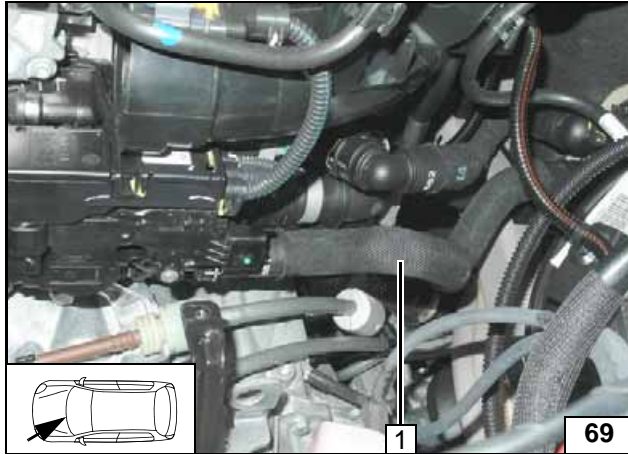

Remove hose 1 from engine outlet/heat exchanger inlet.



Cutting point

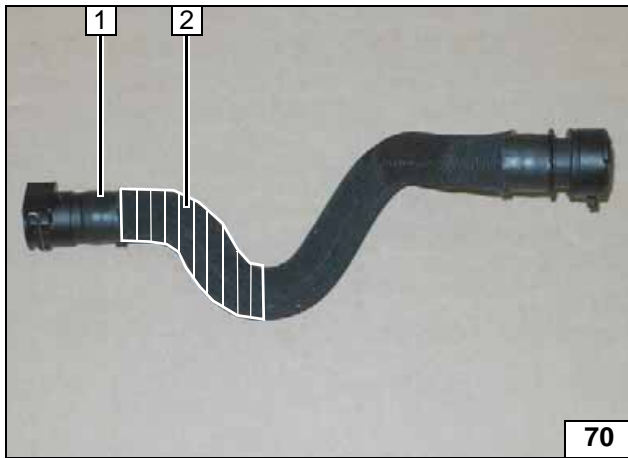

Remove marked section of original vehicle braided protection hose 2.



- 1 Hose of engine outlet / heat exchanger inlet

Removing original vehicle braided protection hose



Cut off hose of engine outlet/heat exchanger inlet at the marking.



Cutting point

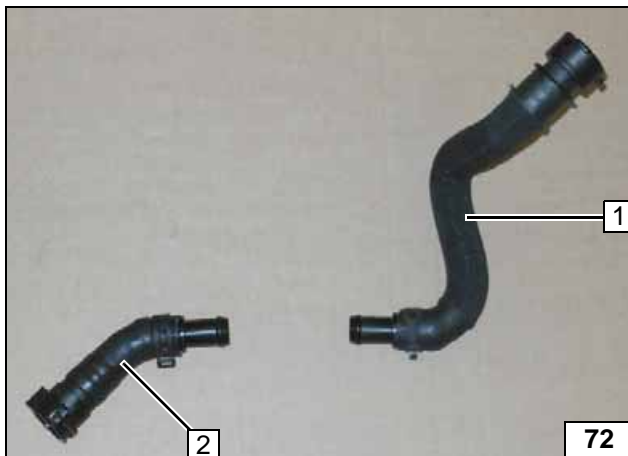

- 1 Heat exchanger inlet hose section
- 2 Engine outlet hose section

Premounting hose sections

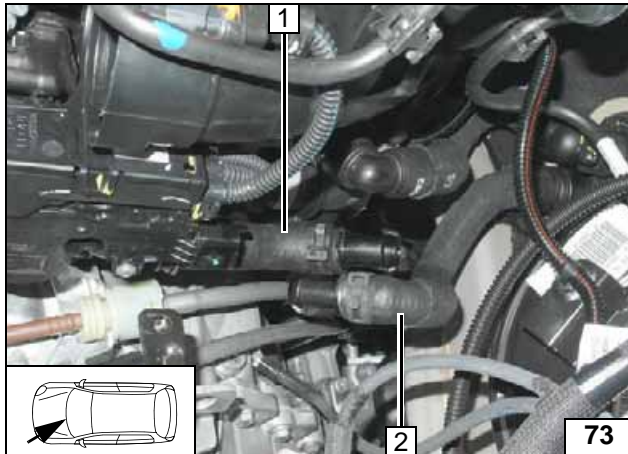

- 1 Engine outlet hose section
- 2 Heat exchanger inlet hose section

Installing hose sections

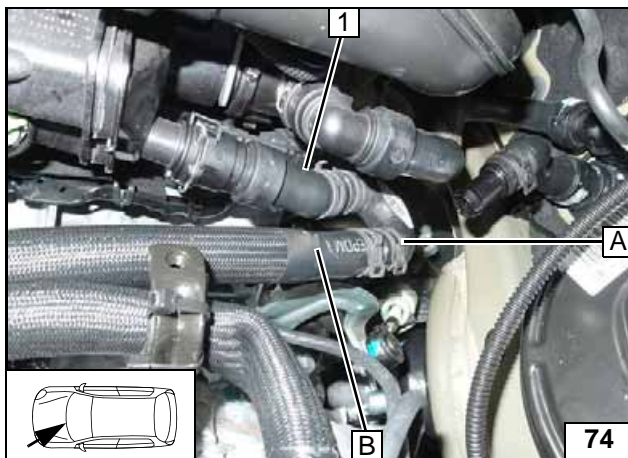

- 1 Engine outlet hose section

Connecting engine outlet

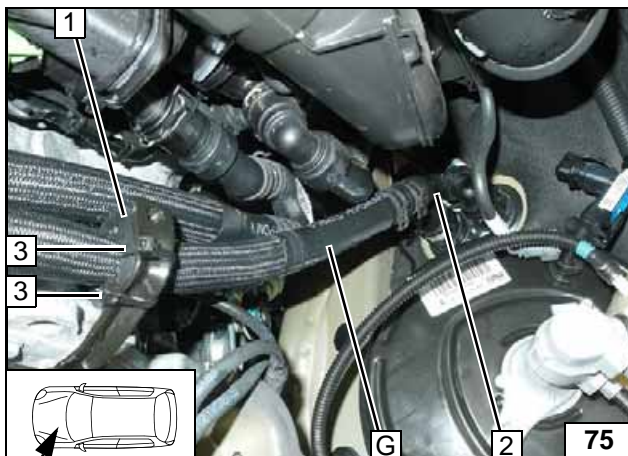

- 1 Slide on black (sw) rubber isolator and align
- 2 Heat exchanger inlet hose section
- 3 Cable tie [2x]

Connecting heat exchanger inlet

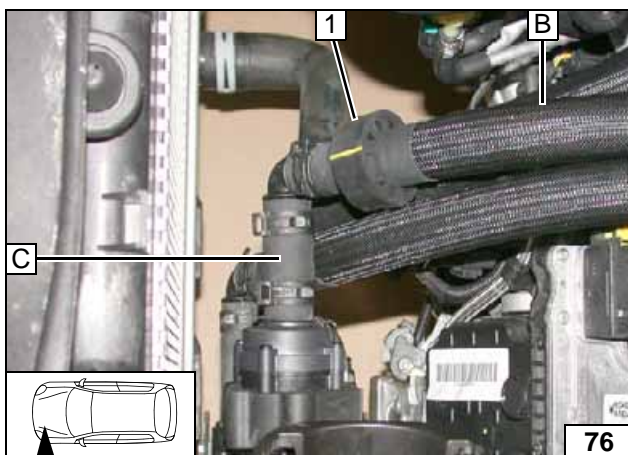

- 1 Slide on black (sw) rubber isolator and align

Connecting circulating pump

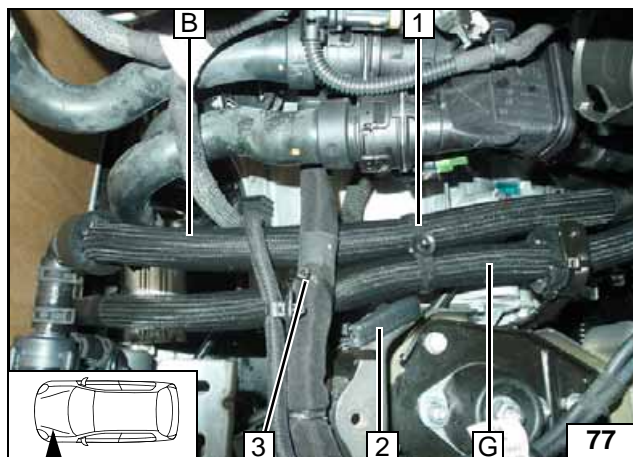

Align hoses.
Ensure sufficient distance from neighbouring components.

- 1 Hose bracket
- 2 Edge protection
- 3 Cable tie



**Installing
hose bracket**

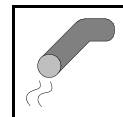

Exhaust Gas

a1 = 160
a2 = 100

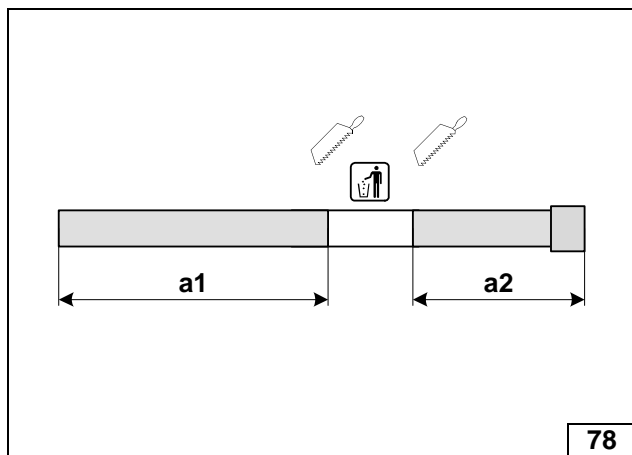

**Preparing ex-
haust pipe**

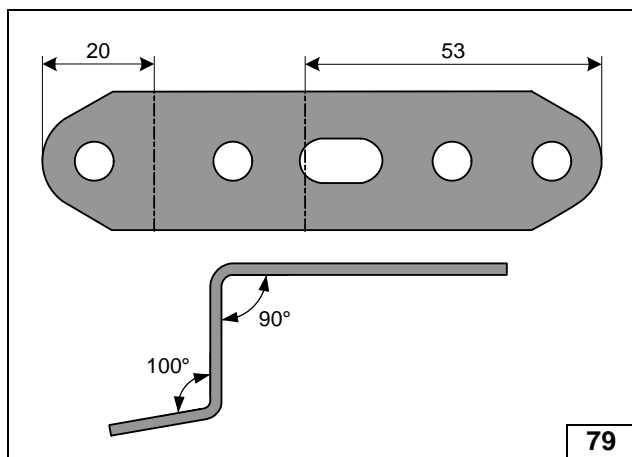

**Angling
down perfor-
ated brack-
et of
silencer**

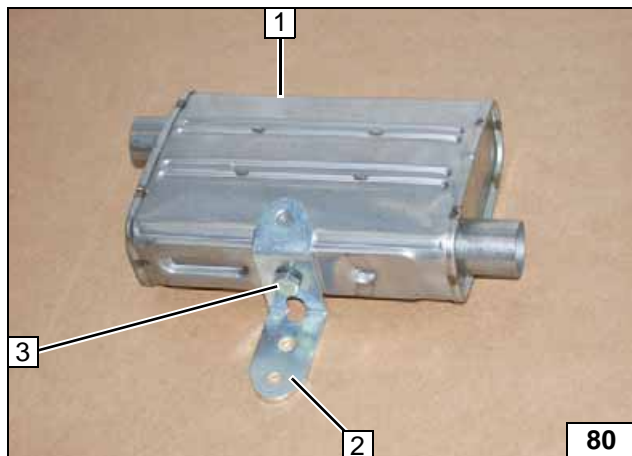

- 1 Silencer
- 2 Perforated bracket
- 3 M6x16 bolt, spring lockwasher

**Premounting
silencer**

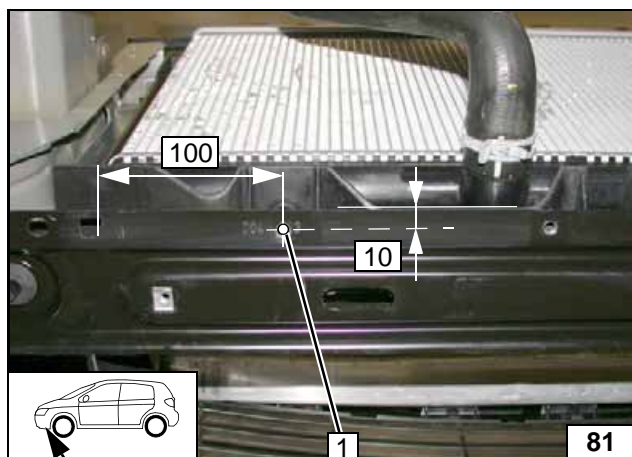

- 1 7 mm dia. hole

**Hole in cross
member**

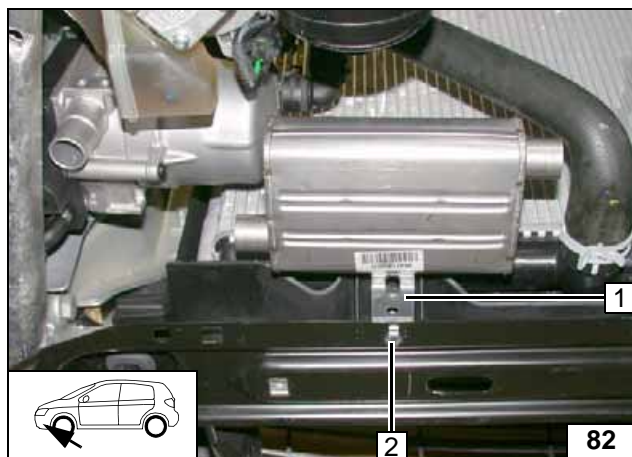
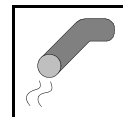

- 1 Perforated bracket
- 2 M6x20 bolt, flanged nut

Installing silencer

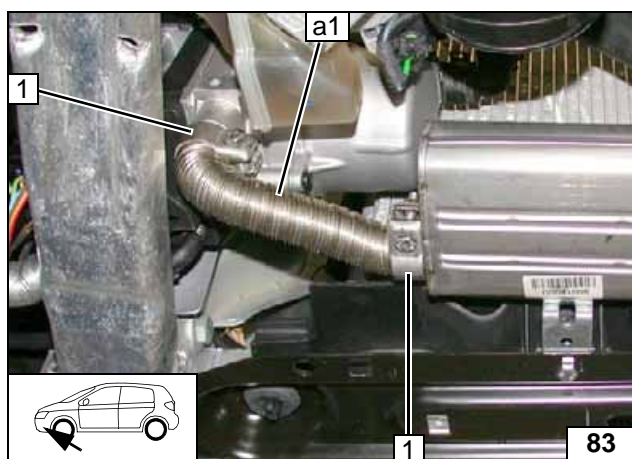

- 1 Hose clamp [2x]

Installing exhaust pipe a1

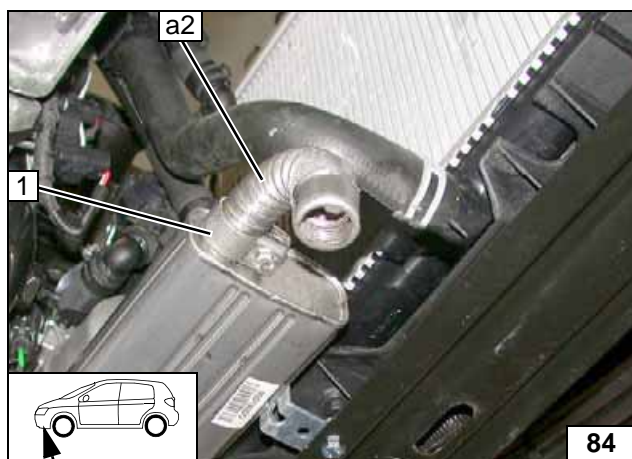

Metallic underride protection

Ensure sufficient distance from neighbouring components, correct if necessary.



- 1 Hose clamp

Installing exhaust pipe a2

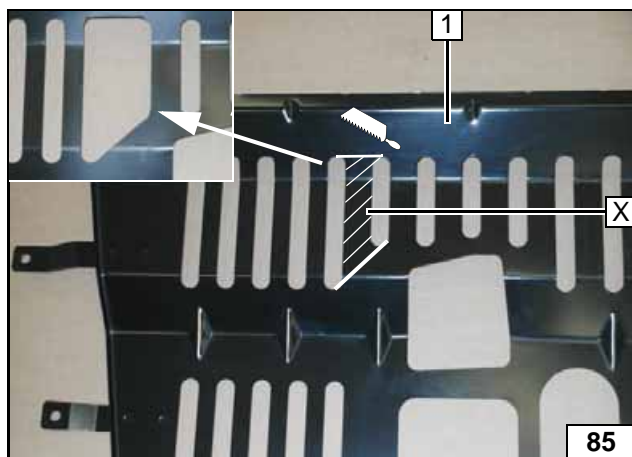

- 1 Metallic underride protection

X =

Cutting out underide protection

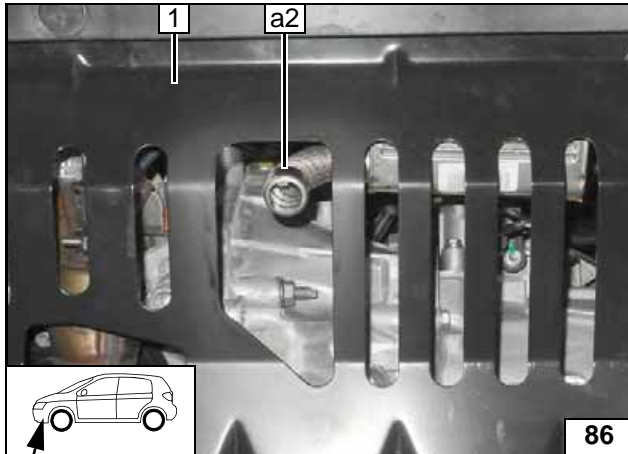
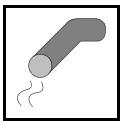

Install underdrive protection. Ensure sufficient distance between silencer and underdrive protection **1**, correct if necessary. Align exhaust pipe **a2** centrally in the recess of underdrive protection **1**.



Aligning exhaust pipe a2

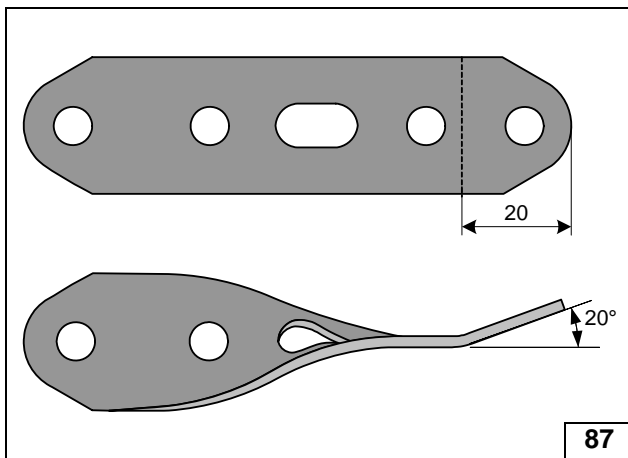

Plastic underdrive protection

Twist perforated bracket by 90° around the longitudinal axis and angle down.



Preparing perforated bracket of exhaust pipe a2

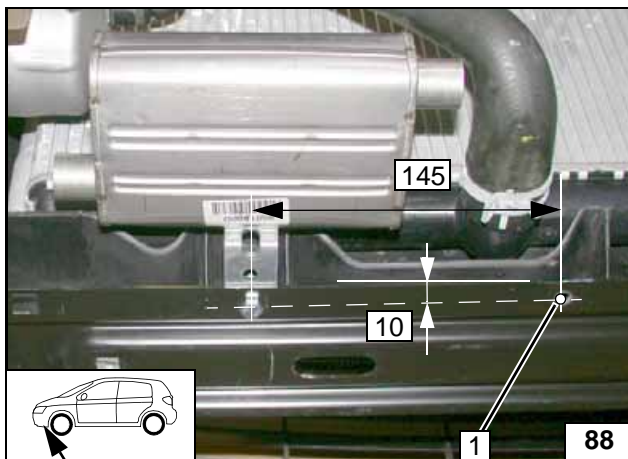

1 7 mm dia. hole

Hole in cross member

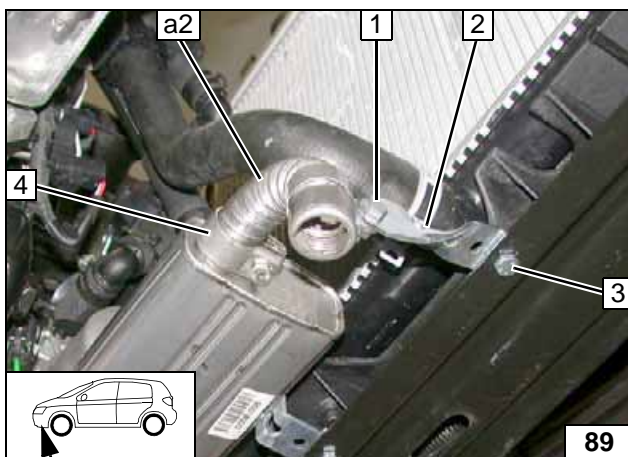

Ensure sufficient distance from neighbouring components, correct if necessary.

- 1** M6x20 bolt, p-clamp, flanged nut
- 3** M6x20 bolt, flanged nut
- 4** Hose clamp



Installing exhaust pipe a2

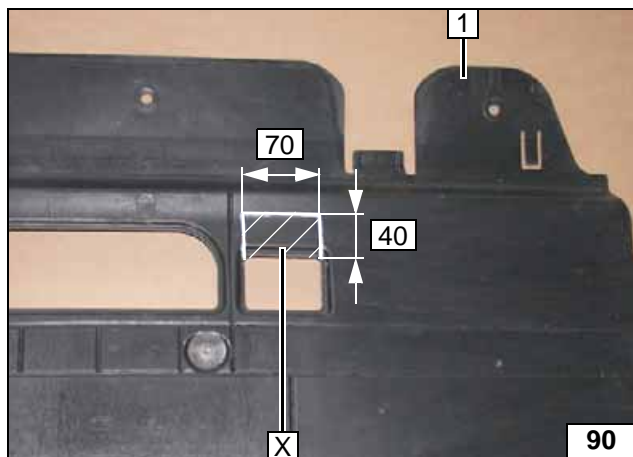
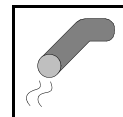

1 Plastic underide protection

X =

Cutting out underide protection

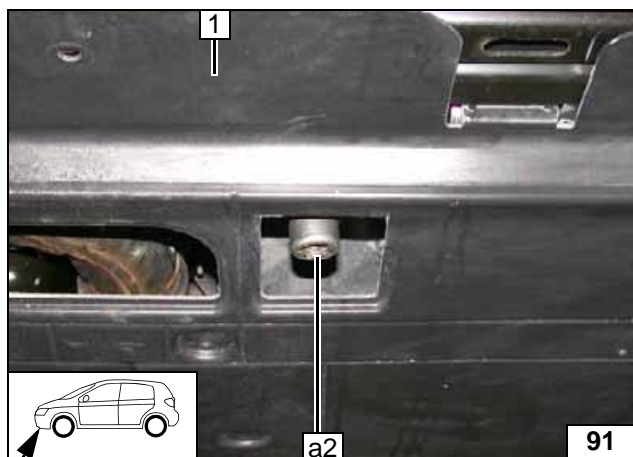

Install underide protection. Ensure sufficient distance between silencer and underide protection 1, correct if necessary. Align exhaust pipe a2 centrally in the recess of underide protection 1.



Aligning exhaust pipe a2



Final Work



Reassemble the components in reverse order. Check all hoses, clamps and all electrical connections for firm seating. Insulate and tie back loose lines.

Only use manufacturer-approved coolant. Spray the heater components with anti-corrosion wax (Tectyl 100K).

- **Connect the battery.**
- **Fill and bleed the coolant circuit according to the vehicle manufacturer's instructions.**
- **Program MultiControl CAR, teach Teleshield transmitter.**
- **For initial start-up and function check, please see installation instructions.**
- **Make settings on the A/C control panel according to the 'operating instructions'.**
- **Place the 'Switch off parking heater before refuelling' caution label near the filler neck.**





Fuel Standpipe Template

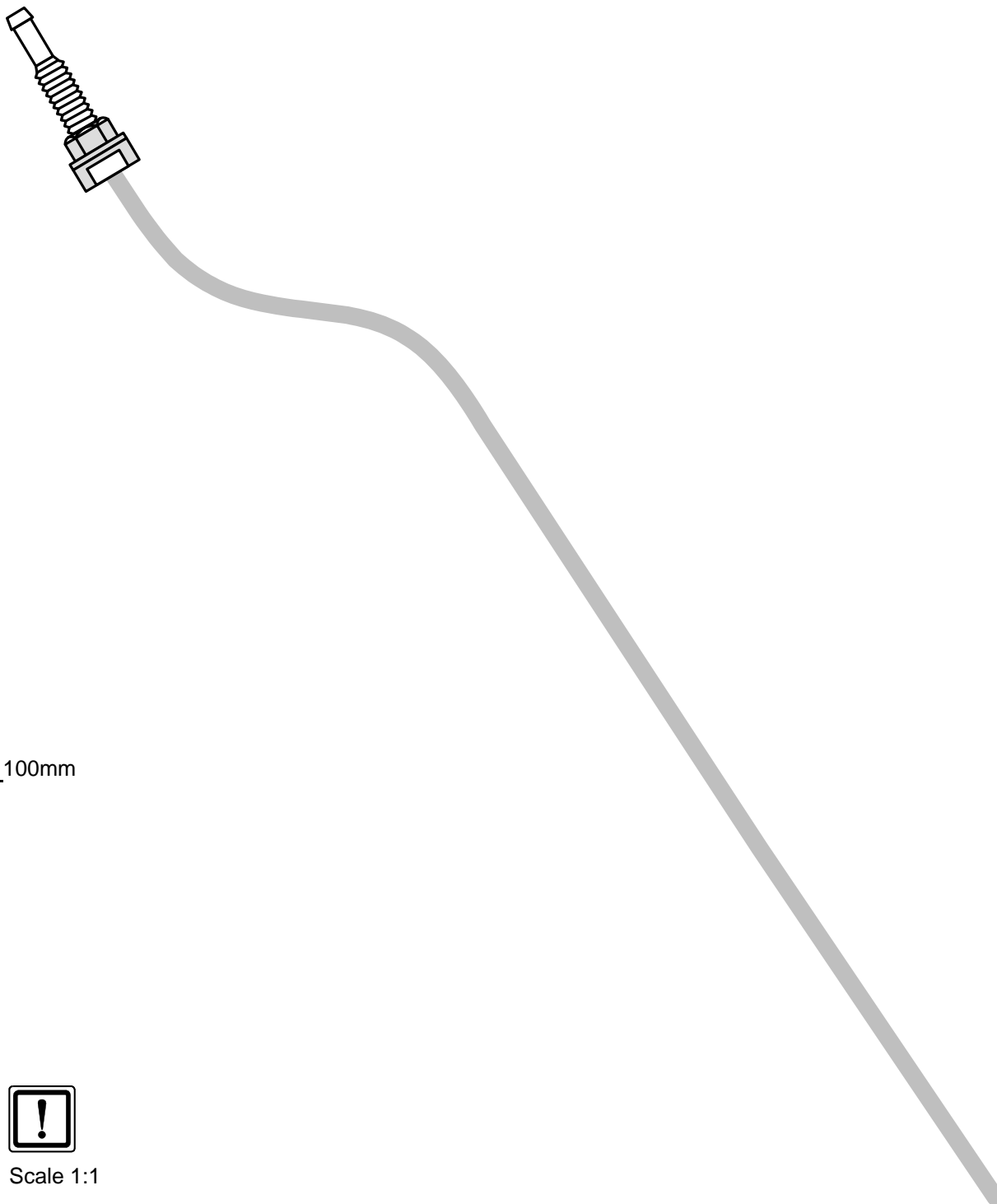

100mm



Scale 1:1

Compare size of printout with dimension lines.
Allowed tolerance a maximum of 2%.

Set the printer settings to 'no margin' or 'minimise margins' and 100% of the normal size.

100mm

0

Operating Instructions for Manual Air-Conditioning

Please remove page and add to the vehicle operating instructions.

Note:

We recommend matching the heating time to the driving time.
Heating time = driving time

Example:

For a driving time of approx. 20 min. (in one direction), we recommend not exceeding a switch-on time of 20 min.

Passenger compartment monitoring, if installed, must be deactivated in addition to the vehicle settings for the heating operation.

For instructions on deactivation, please refer to the operating instructions of the vehicle.

Before parking the vehicle, make the following settings:

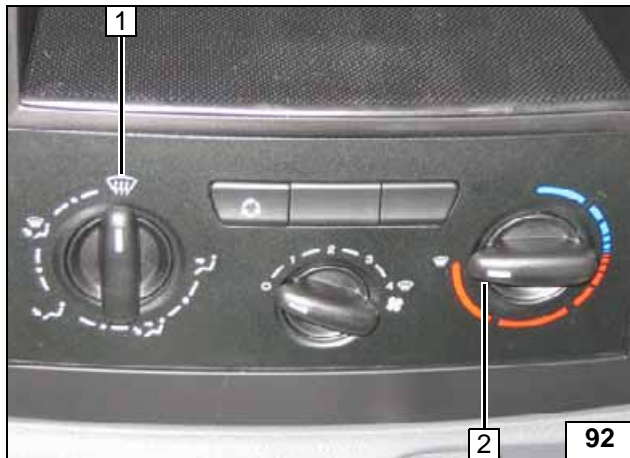

- 1 Air outlet to windscreen
- 2 Set temperature to 'max.'

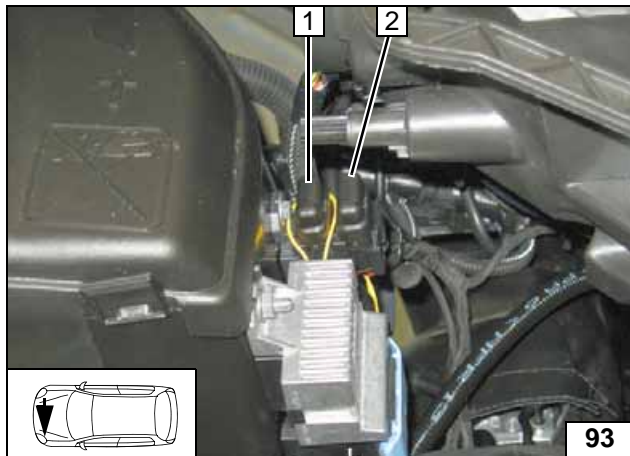

- 1 30A passenger compartment main fuse F2
- 2 20A heater fuse F1

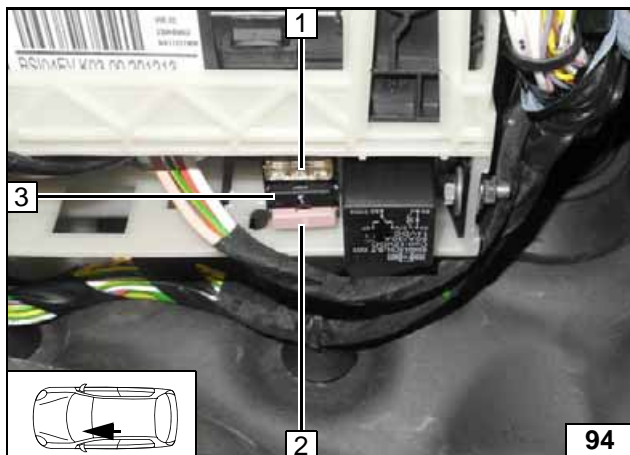

- 1 25A fan fuse F4
- 2 3A fan controller fuse F5
- 3 1A heater control fuse F3



A/C control panel

Engine compartment fuses

Passenger compartment fuses

