

M Installation documentation

Thermo Top Evo Cold start for water heater

Jeep Compass

Left-hand drive vehicle

Manufacturer	Model	Type	Model year	EG-BE-No. / ABE
Jeep	Compass	MX	from 2017	e11* 2007/46* 4037*...

Motorisation	Fuel	Emission standard	Transmission type	Output [kW]	Displacement [cm ³]	Engine code
1.4P	Petrol	Euro 6	SG	103	1368	T247088
1.4P	Petrol	Euro 6	AG	125	1368	T663549
1.6D	Diesel	Euro 6	SG	88	1598	T690240
2.0D	Diesel	Euro 6	AG	103	1998	T655509

Total installation time	Note
1.5 hours	Applies only to the retroffing of a cold start system in vehicles with an already retrofitted parking heater

Contents

1	List of abbreviations	3
2	Installation notes	4
2.1	Information on Validity	4
2.2	Components used	4
2.3	Validity Notes	4
2.4	Information on total installation time	4
3	About this document	5
3.1	Purpose of the document	5
3.2	Warranty and liability	5
3.3	Safety	5
3.4	Using this document	6
4	Technical Information	7
5	Installation overview	8
6	Electrical system	9
6.1	Electrical system preparation	9
6.2	Wiring diagram	11
6.3	CLR module installation	13
6.4	Passenger compartment connection	14
6.5	Connection of engine control unit for petrol vehicles	15
6.6	Connection of engine control unit for diesel vehicles	17
7	Final work	19

1 List of abbreviations

AG	Automatic transmission
CLR	Cold start module
RTD	Temperature sensor
SG	Manual transmission

2 Installation notes

2.1 Information on Validity

This installation documentation applies to vehicles listed on page 1, assuming technical modifications to the vehicle do not affect installation, any liability claims excluded.



Vehicle and engine types, equipment variants and other specifications not listed in this installation documentation have not been tested. The installation is not permitted.

2.2 Components used

Designation	Order number
Additional kit for cold start Jeep Compass 2017 petrol and diesel	1325525C
Installation documentation for cold start Jeep Compass 2017 petrol and diesel	1326181D

2.3 Validity Notes

This installation documentation applies only in combination with:

Designation	Order number
Installation kit (including cold start kit) for Jeep Compass 2017 petrol and diesel	1326108_
Installation documentation for Jeep Compass 2017 petrol and diesel	1326107_

2.4 Information on total installation time

The total installation time includes the time needed for mounting and demounting the vehicle-specific components, the cold start-specific installation times and all other times required for the subsequent installation of the cold start kit with a parking heater that has already been retrofit.

The total installation time may vary for vehicle equipment other than provided.

3 About this document

3.1 Purpose of the document

This installation documentation is part of the product and contains all the information required to ensure professional vehicle specific installation of the:

Cold start kit

3.2 Warranty and liability

Webasto shall assume no liability for defects, damage and injuries resulting from a failure to observe the installation, repair and operating instructions of the information contained in them.

This liability exclusion particularly applies to improper installations and repairs by untrained persons or in the case of a failure to use genuine spare parts.

The liability due to culpable disregard to life, limb or health and due to damage or injuries caused by a wilful or reckless breach of duty remain unaffected, as does the obligatory product liability.

Installation should be carried out according to the general, standard rules of technology. Unless specified otherwise, fasten hoses, lines and wiring harnesses to original vehicle lines and wiring harnesses using cable ties. Insulate loose wire ends and tie back. Connectors on electronic components must audibly snap into place during assembly.

Spray unfinished body areas, e.g. drilled holes, with anti-corrosion wax (Tectyl 100K).

Observe the instructions and guidelines of the respective vehicle manufacturer for demounting and mounting vehicle specific components.

The initial start-up is to be executed with the Webasto Thermo Test Diagnosis.

When installing a programmable control module (e.g. a PWM Gateway), the corresponding settings must be checked or adjusted.

3.2.1 Statutory regulations governing installation

The Thermo Top Evo heater has been type-tested and approved in accordance with ECE-R 10 (EMC) and ECE-R 122 (heater). The regulations of these guidelines are binding in the scope of the Directive 70/156/EEC and/or 2007/46/EC (for new vehicle models from 29/04/2009) and should also be observed in countries in which there are no special regulations.

The heater is licensed in accordance with paragraph 19, section 3, No. 2b of the StVZO (German Road Traffic Licensing Authority).

3.3 Safety

Qualifications of installation personnel

The installation personnel must have the following qualifications:

- Successful completion of Webasto training
- Corresponding qualification for working on technical systems

Regulations and legal requirements

The regulations from the heater's general installation and operating instructions must be observed.

3.3.1 Safety information on installation

Danger posed by live parts

- ▶ Prior to installation, disconnect the vehicle from the voltage supply.
- ▶ Make sure the electrical system is earthed correctly.
- ▶ Always comply with legal requirements.
- ▶ Observe data on type label.

Danger of fire and leaking toxic gases due to improper installation

- ▶ Vehicle parts in the vicinity of the heater must be protected against excessive heating by the following measures:
 - ⇒ Maintain minimum safety distances.
 - ⇒ Ensure adequate ventilation.
 - ⇒ Use fire-resistant materials or heat shields.

Danger due to sharp edges

- Lacerations
- Short circuit due to electrical wire damage
- ▶ Fit protectors on sharp edges.

3.4 Using this document

Before installing, read this installation documentation, the installation instructions of the heater, the operating instructions and supplementary sheets provided.

3.4.1 Explanatory Notes on the Document:

There is an identification mark near the respective work step to allow you to quickly allocate the other applicable documents to the Webasto components to be installed:

Generally valid Webasto documentation	
Vehicle-specific installation documentation	
Vehicle-specific installation documentation of the cold start kit	
Webasto Comfort A/C control	
Webasto Standard A/C control	
Tank extracting device (e.g. FuelFix)	
Exhaust end fastener (EFIX)	
Combustion air intake silencer	
Spacer bracket (ASH)	

3.4.2 Use of symbols



DANGER

Type and source of the risk

Consequences: Failure to follow the instructions can result in death

► Actions to protect yourself against risks.



WARNING

Type and source of the risk

Consequences: Failure to follow the instructions can lead to serious or even fatal injuries

► Actions to protect yourself against risks.



CAUTION

Type and source of the risk

Consequences: Failure to follow the instructions can lead to minor injuries

► Actions to protect yourself against risks.



Type and source of the risk

Consequences: Failure to follow the instructions can lead to material damage

► Actions to protect yourself against risks.



Reference to the vehicle manufacturer's specific documents.



a note on a special technical feature

3.4.3 Work step identification marks

The ongoing work step is indicated on the outside top corner of the page:

Mechanical system	Electrical system	High-voltage	Coolant
Combustion air	Fuel	Exhaust	Software

3.4.4 Orientation aid

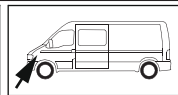
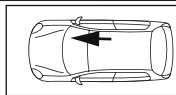

The arrow indicates the position on the vehicle and the viewing angle

3.4.5 Use of highlighting

Highlight	Explanation
►	Necessary action
⇒	Result of an action
1 / 12 / a1	Position numbers for the image descriptions
① / ⑫ / Ⓐ	Position numbers for the image descriptions for electrical wires and wiring harnesses and coolant hose sections

4 Technical Information

Dimension specifications

- All dimensions specified in mm
- Perforated brackets and mounting angles are shown to scale
- Observe data regarding scale on the templates

Tightening torque specifications

- Tighten all screw connections in accordance with manufacturer's instructions or in accordance with state-of-the-art-technology

Necessary special tools

- Automatic wire stripper 0.2 - 6 mm²
- Crimping pliers for cable lugs 0.5 – 10 mm²
- Crimping pliers for male connector 0.14 – 6 mm²
- Crimping pliers for connector 0.25 – 6 mm²
- Torque wrench for 2.0 - 10 Nm
- Deep-hole marker

5 Installation overview

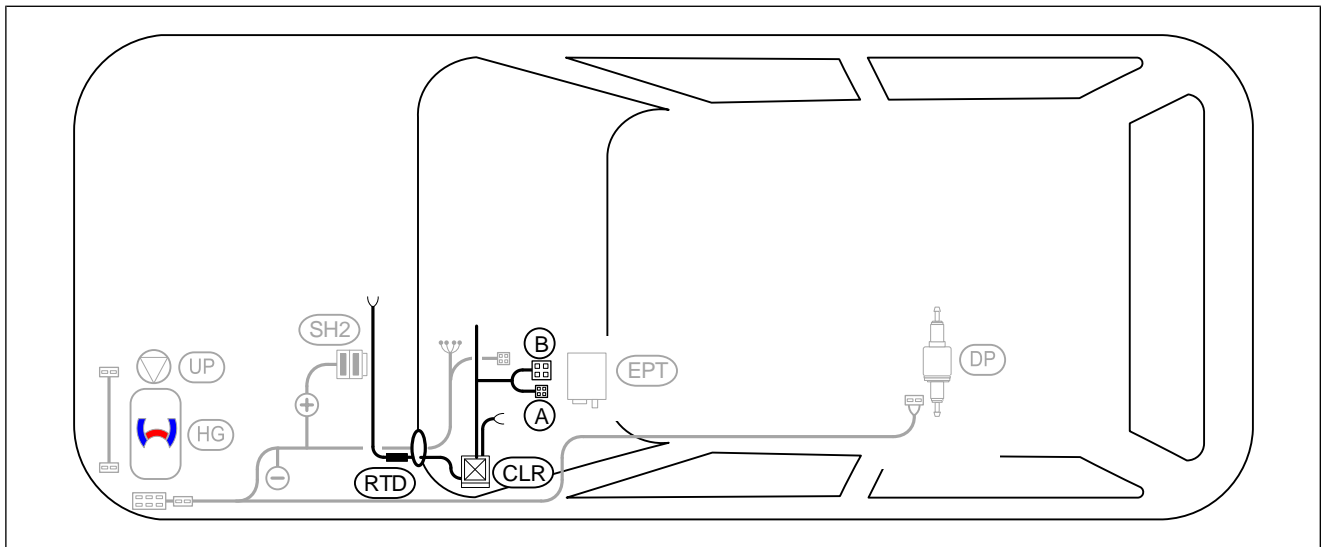

Fig. 1

Legend to installation overview

Abbreviation	Component
CLR	CLR module
RTD	Temperature sensor
A/B	Adapter connector



6 Electrical system

6.1 Electrical system preparation

Assigning wires

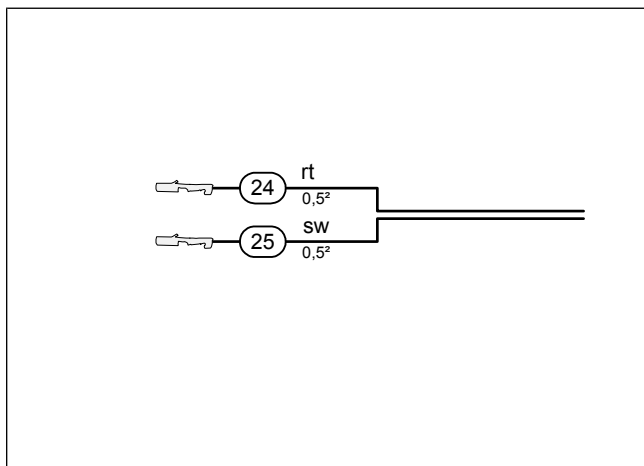

Fig. 2

- ②4 Red (rt) wire of cold start wiring harness
- ②5 Black (sw) wire of cold start wiring harness

Preparing angle bracket

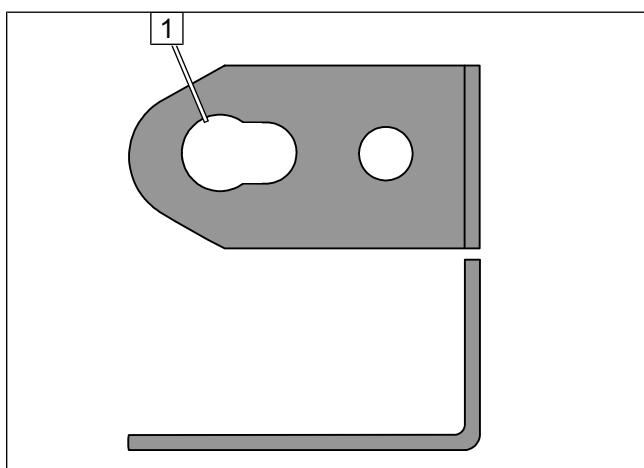

Fig. 3

- Drill out oblong hole at position **1** to $\text{Ø}10$.

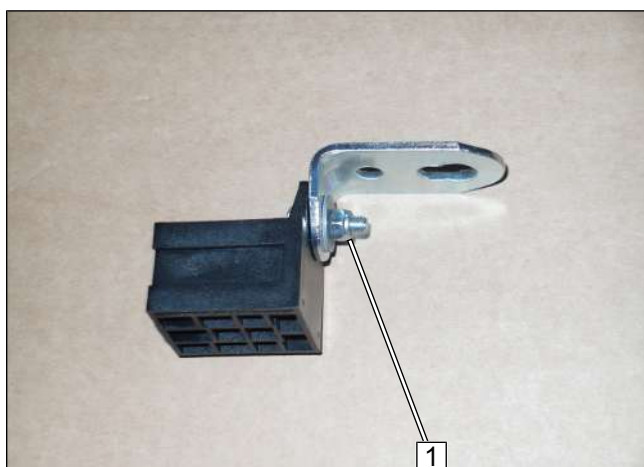

Fig. 4

- 1** M5x16 bolt, large diameter washer, CLR module socket, angle bracket, large diameter washer, nut



Preparing CLR module

- ▶ Detach black (sw) wire from terminal A and insulate.
- ▶ Connect red (rt) wire (24) and black (sw) wire (25) and mount flat spring contact (1).

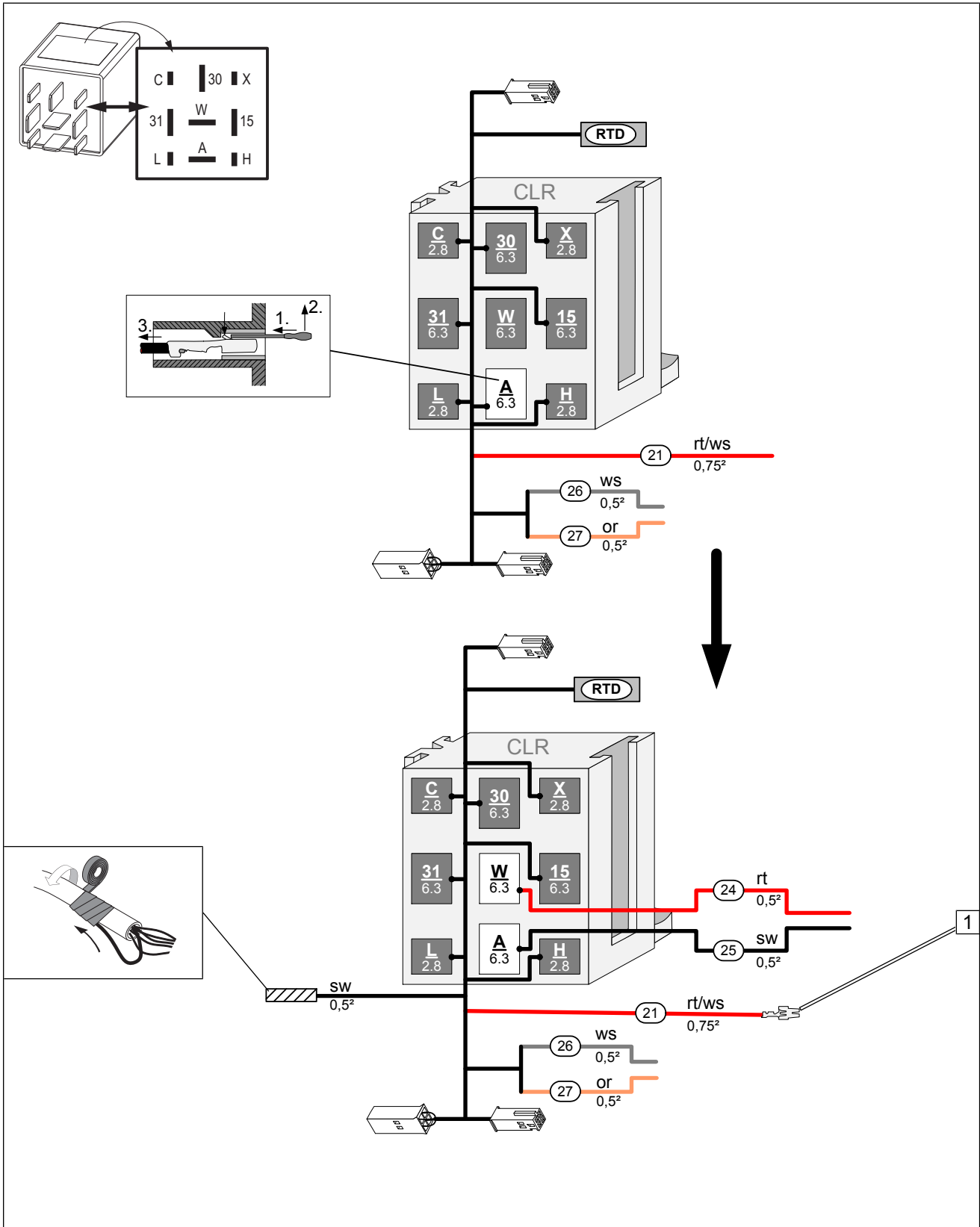

Fig. 5



6.2 Wiring diagram

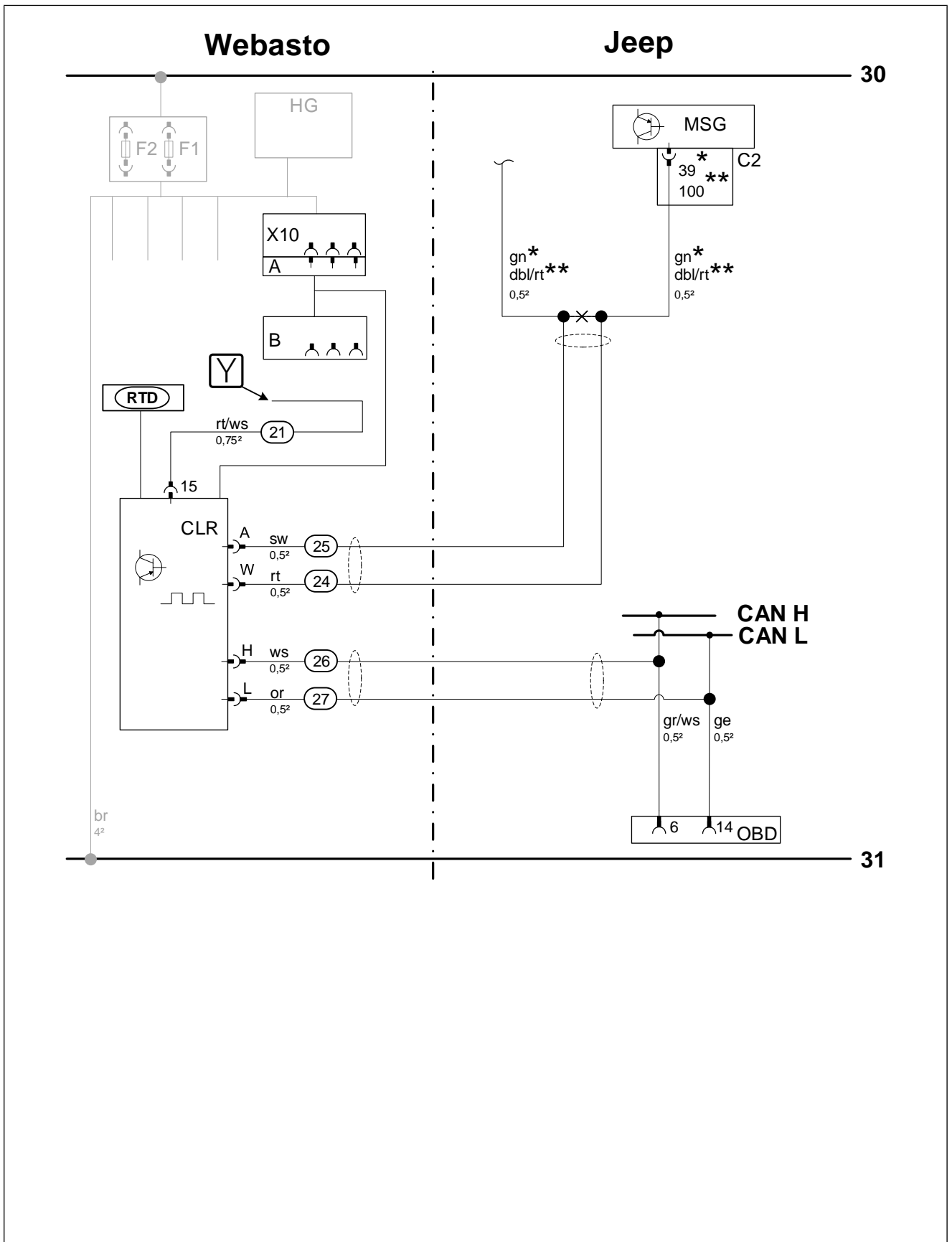

Fig. 6



Legend to wiring diagram



The vehicle connector and component designations are freely chosen by Webasto.
Cable colours may vary.

Vehicle components		Symbols	
Abbreviation	Component	Abbreviation	Designation
MSG	Engine control unit	X	Cutting point
C2	60-pin MSG connector for petrol / 105-pin for diesel	*	Petrol
OBD	ON-Board Diagnosis	**	Diesel
		Y	The connection is carried out in the "fan controller" section with the A/C control installation documentation

Webasto components		Cable colours	
Abbreviation	Component	Abbreviation	Colour
A	Male plug for CLR module wiring harness	bg	beige
B	Female plug for CLR module wiring harness	bl	blue
C	Male plug for adapter wiring harness	br	brown
D	Female plug for adapter wiring harness	dbl	dark blue
E	Male plug for Plug&Play wiring harness	dgn	dark green
F	Female plug for Plug&Play wiring harness	ge	yellow
CCL GW	CAN CAN LIN Gateway	gn	green
CL GW	CAN LIN Gateway	gr	grey
CLR	Cold start module	hbl	light blue
D1	Diode	hgn	light green
D2	Diode group	or	orange
F0	Additional fuse for power supply	pk	pink
F1	Heater main fuse	rt	red
F2	Passenger compartment fan controller main fuse	sw	black
F3	Control element fuse	vi	violet
F4	Fan controller fuse	ws	white
F5	Additional fuse		
HG	Heater TT-Evo		
K1	Relay K1		
K2	Relay K2		
K3	Relay K3		
LIN GW	LIN Gateway		
PWM GW	Pulse width modulator gateway		
RSH	Relay and fuse holder of passenger compartment		
RTD	Temperature sensor		
X10	Female plug for control element		
Y	Power adapter		



6.3 CLR module installation

Mounting CLR module socket

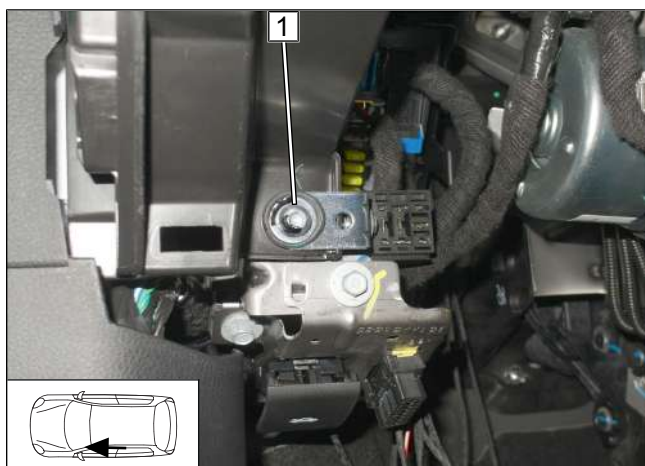

Fig. 7



Produce all following electrical connections as shown in the system wiring diagram.

- Route wires **(24)** and **(25)** as well as temperature sensor **(RTD)** through the cable grommet in the engine compartment.

- 1** Original vehicle bolt

Installing CLR module

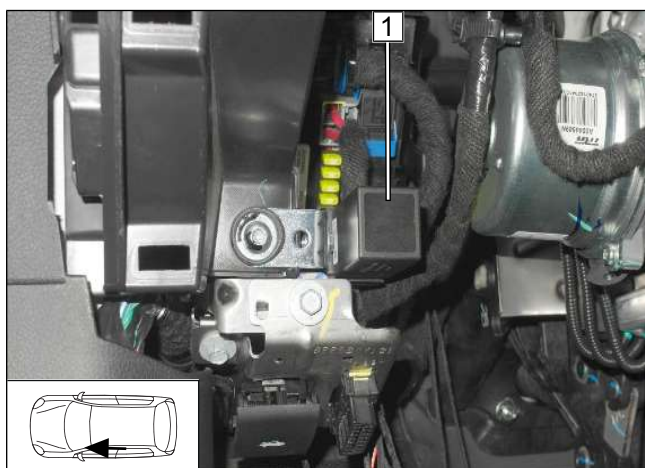

Fig. 8

- 1** CLR module

Mounting RTD

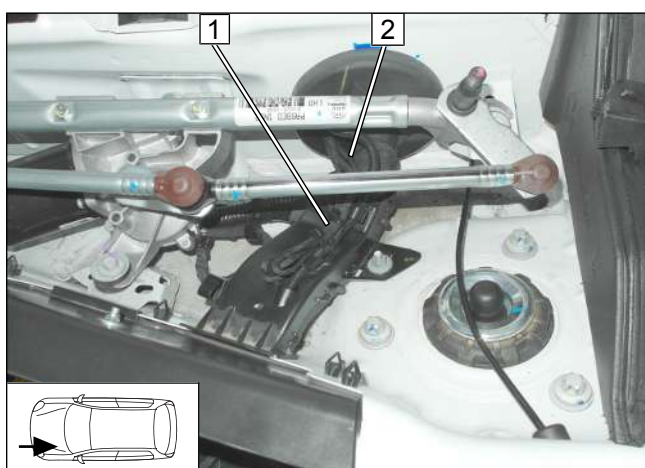

Fig. 9

- Route wires **(24)** and **(25)** to the engine control unit.

- 1** Fasten temperature sensor **(RTD)** using a cable tie



6.4 Passenger compartment connection

Connection to OBD socket outlet

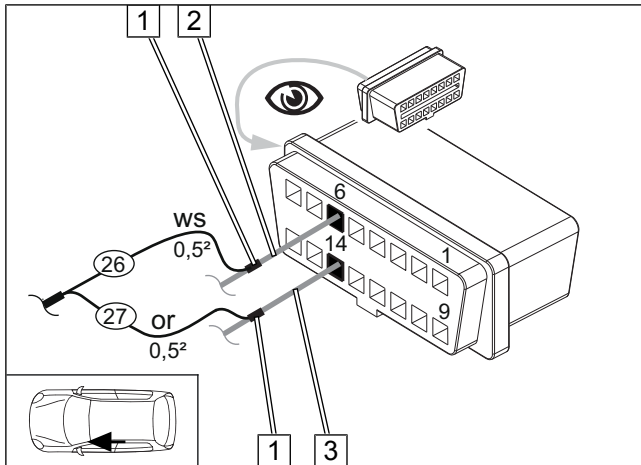

Fig. 10



Further information can be found in the vehicle manufacturer's technical documentation.

► Remove OBD socket outlet from bracket.



► Crimp and shrink butt connector **1**

- 2** Grey/white (gr/ws) wire of OBD socket outlet/ pin 6
- 3** Yellow (ge) wire of OBD socket outlet/ pin 14
- 26** White (ws) wire of CLR module/ H cold start wiring harness
- 27** Orange (or) wire of CLR module/ L cold start wiring harness



6.5 Connection of engine control unit for petrol vehicles

View of connector C2

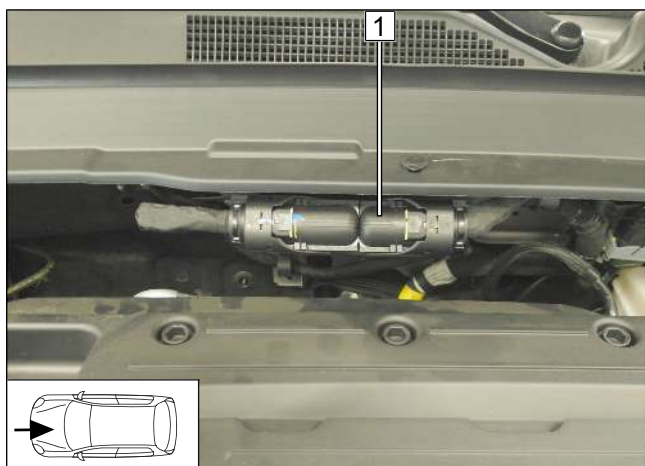

Fig. 11

- 1 60-pin connector C2 of engine control unit

View of connector C2 of engine control unit on contact side

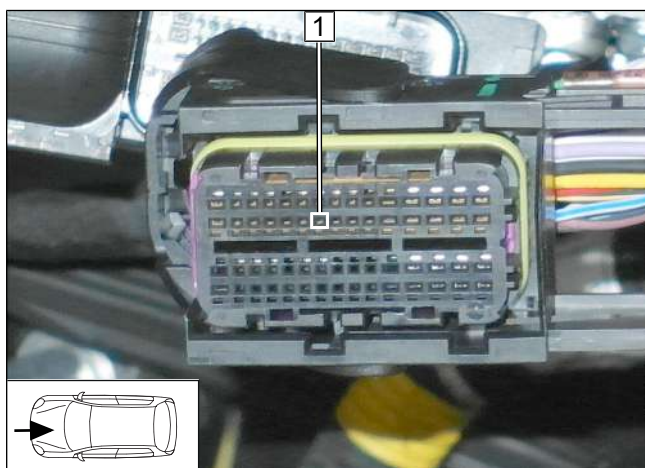

Fig. 12

- 1 60-pin connector C2 of engine control unit/pin 39

View of connector C2 of engine control unit on wiring side

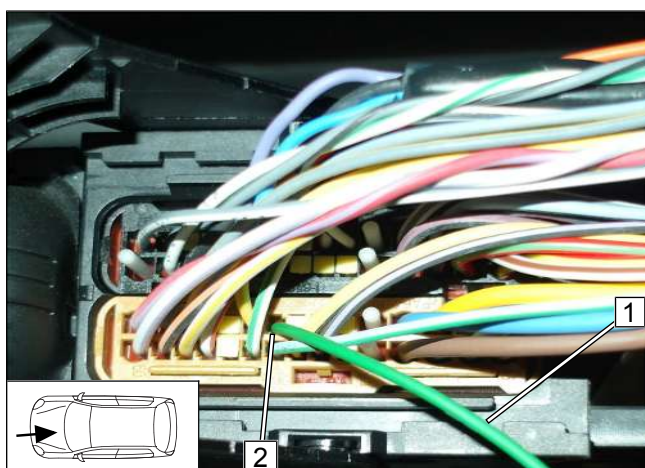

Fig. 13

► Remove the cover from connector C2.

- 1 Green (gn) wire
- 2 60-pin connector C2 of engine control unit/pin 39



Connection to engine control unit

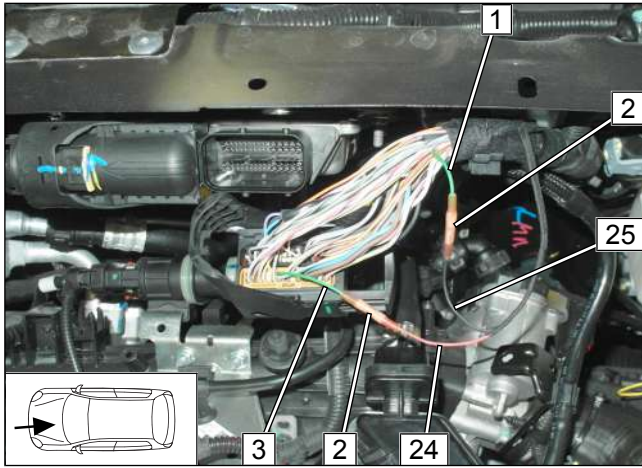

Fig. 14



► Crimp and shrink butt connector **2**.

- 1** Green (gn) wire
- 3** Green (gn) wire of 60-pin connector C2 of engine control unit/pin 39
- 24** Red (rt) wire of CLR module/W from cold start wiring harness
- 25** Black (sw) wire of CLR module/A from cold start wiring harness



6.6 Connection of engine control unit for diesel vehicles

View of connector C2

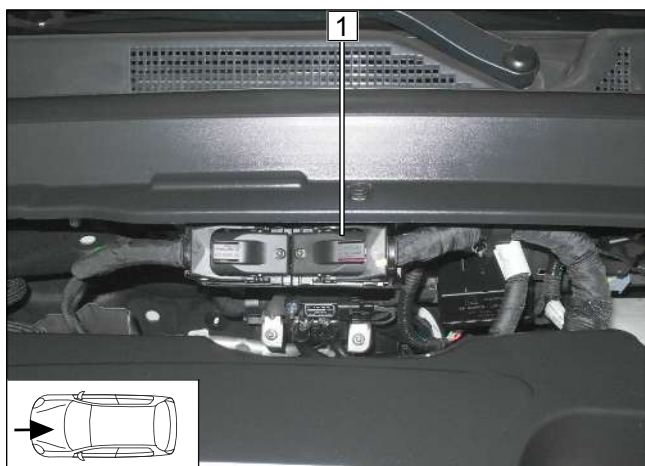

Fig. 15

- 1 105-pin connector C2 of engine control unit

View of connector C2 of engine control unit on contact side

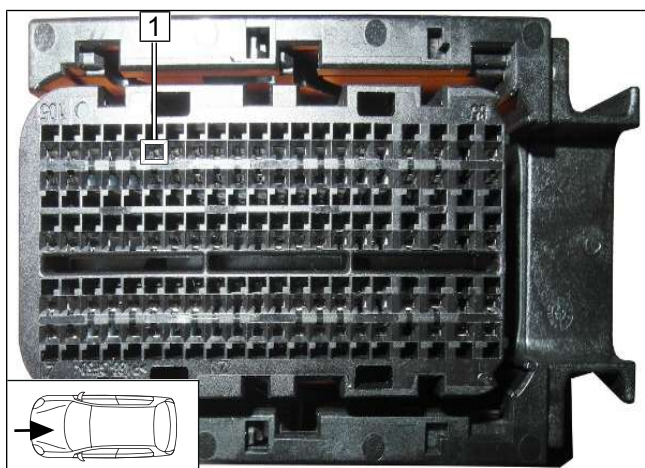

Fig. 16

- 1 105-pin connector C2 of engine control unit/pin 100

View of connector C2 of engine control unit on wiring side

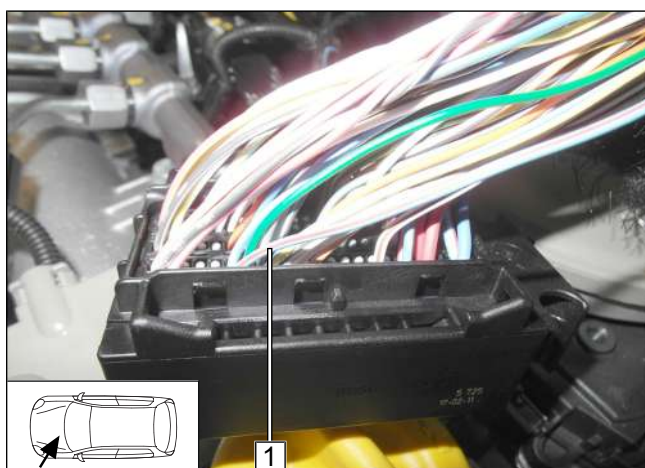

Fig. 17

► Remove the cover from connector C2.

- 1 Dark blue/red (dbl/rt) wire of 105-pin engine control unit connector C2/ pin 100



Connection to engine control unit

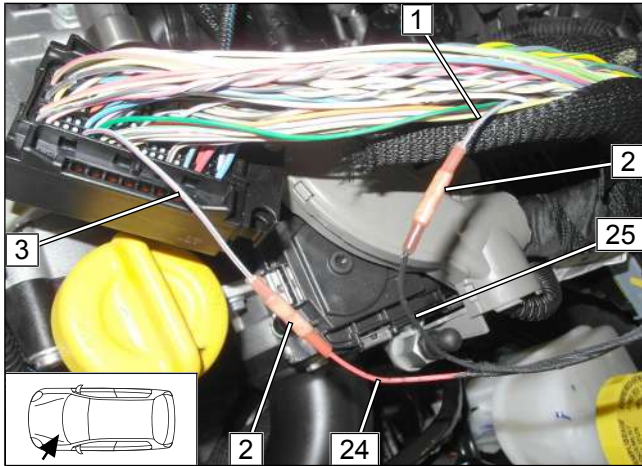

Fig. 18



► Crimp and shrink butt connector **2**.

- 1** Dark blue/red (dbl/rt) wire
- 3** Dark blue/red (dbl/rt) wire of 105-pin engine control unit connector C2/ pin 100
- 24** Red (rt) wire of CLR module/W from cold start wiring harness
- 25** Black (sw) wire of CLR module/A from cold start wiring harness



7 Final work



- ▶ Final work is not carried out until the installation of the heater in the vehicle has been completed
- ▶ Check all electrical connections for firm seating
- ▶ Insulate and tie back loose lines



These are the original instructions. The German language is binding.
You can request your language if it is missing. The telephone number of each country can be found in the Webasto service centre leaflet or the website of the respective Webasto representative of your country.

Ident No. 1326181D_EN • 06/19 • Errors and omissions excepted • © Webasto Thermo & Comfort SE • 2019

Webasto Thermo & Comfort SE
Postfach 1410
82199 Gilching
Germany

Company address:
Friedrichshafener Str. 9
82205 Gilching
Germany

Technical Extranet: <https://dealers.webasto.com>



WWW.WEBASTO.COM