



Water Heater

Thermo Top Evo Parking Heater



Installation Documentation Renault Scenic

Validity

Manufacturer	Model	Type	Model year	EG BE No. / ABE
Renault	Scenic	RFA	From model year 2017	e2 * 2007 / 46 * 0574 * ...

Motorisation	Fuel	Emission standard	Transmission type	Output in kW	Displacement in cm ³	Engine code
1.5 D	Diesel	Euro 6	7-speed DKG	81	1461	K9K

DKG = dual clutch transmission EDC

Left-hand drive vehicle

Verified equipment variants: Two zone automatic air-conditioning
LED main headlights incl. cornering light
LED daytime running lights
Halogen front fog lights
Headlight washer system
Start button with keycard
4 WD

Not verified: Halogen main headlights
LED front fog lights
Grand Scenic

Total installation time: approx. 9.3 hours

Renault Scenic

Table of Contents

Validity	1	Preparing Installation Location	11
Necessary Components	2	Preparing Bracket	15
Installation Instructions	2	Preparing Heater	16
Information on Total Installation Time	2	Installing Heater	18
Information on Operating and Installation Instructions	3	Coolant Circuit	19
Information on Validity	4	Fuel	21
Technical Information	4	Installing FuelFix	22
Explanatory Notes on Document	4	Combustion Air	28
Preliminary Work	5	Exhaust Gas	30
Heater Installation Location	5	Exhaust End Fastener Installation	31
Preparing Electrical System	6	Final Work	33
Electrical System	7	FuelFix Template	34
Air-Conditioning Control	8		
Heater Control Installation	8		
Remote Option (Telestart)	8		
ThermoCall Option	9		

Necessary Components

Description	Order No.:
Basic delivery scope of Thermo Top Evo	In accordance with price list
Installation kit for Renault Scenic 2017 petrol and Diesel	1325453B
Additional 'Webasto Standard' A/C control kit for Renault Scenic or Additional 'Webasto Comfort' A/C control kit for Renault Scenic	1324475_ 1324908_
In case of Telestart, heater control, as well as indicator lamp in consultation with end customer	In accordance with price list
Note	
The installation location should be confirmed with the end customer in case of MultiControl.	

Installation Instructions

Arrange for the vehicle to be delivered with the tank only about ¼ full.

The installation location of the push button in case of Telestart or ThermoCall should be confirmed with the end customer. Depending on the space required and the vehicle manufacturer's instructions, we recommend the use of a vehicle battery with a higher electrical capacity.

Information on Total Installation Time

The total installation time includes the time needed for mounting and demounting the vehicle-specific components, the heater specific installation time and all other times required for the system integration and initial start-up of the heater. The total installation time may vary for vehicle equipment other than provided.

Information on Operating and Installation Instructions

1 Important information (not complete)

1.1 Installation and repair



The improper installation or repair of Webasto heating and cooling systems can cause fire or the leakage of deadly carbon monoxide, leading to serious injury or death.



To install and repair Webasto heating and cooling systems you need to have completed a special company training course and have the appropriate technical documentation, special tools and special equipment.



Installation and repair may ONLY be carried out by persons trained and certified in a Webasto training course. NEVER try to install or repair Webasto heating or cooling systems if you have not completed a Webasto training course, you do not have the necessary technical skills and you do not have the technical documentation, tools and equipment available to ensure that you can complete the installation and repair work properly.

Only use genuine Webasto parts. See the Webasto air and water heaters accessories catalogue for this purpose.

1.2 Operation

To ensure safe operation, we recommend having the heater checked every two years by an authorised Webasto dealer, especially when used over a long period and/or under extreme environmental conditions.

Do not operate the heater in closed rooms due to the danger of poisoning and suffocation.

Always switch off the heater before refuelling.

The heater may only be used with the prescribed fuel diesel (DIN EN 590) or petrol (DIN EN 228).

The heater may not be cleaned with a high-pressure cleaner.

1.3 Please note

ALWAYS follow all Webasto installation and operating instructions and observe all warnings.

To become familiar with and understand all functions and properties of the heater, the operating instructions must be read carefully and observed at all times.

For proper, safe installation and repair work, the installation instructions with all warnings and safety information must be carefully read and observed at all times. Please always contact a workshop authorised by Webasto for all installation and repair work.

Important

Webasto shall assume no liability for defects, damage and injuries resulting from a failure to observe the installation, repair and operating instructions of the information contained in them.

This liability exclusion particularly applies to improper installations and repairs, installations and repairs by untrained persons or in the case of a failure to use genuine spare parts.

The liability due to culpable disregard to life, limb or health and due to damage or injuries caused by a wilful or reckless breach of duty remain unaffected, as does the obligatory product liability.

Installation should be carried out according to the general, standard rules of technology. Unless specified otherwise, fasten hoses, lines and wiring harnesses to original vehicle lines and wiring harnesses using cable ties. Insulate loose wire ends and tie back. Connectors on electronic components must audibly snap into place during assembly.

Sharp edges should be fitted with rub protection. Spray unfinished body areas, e.g. drilled holes, with anti-corrosion wax (Tectyl 100K).

Observe the instructions and guidelines of the respective vehicle manufacturer for demounting and mounting vehicle specific components!

The initial start-up is to be executed with the Webasto Thermo Test Diagnosis.

When installing a programmable control module (e.g. a PWM Gateway), the corresponding settings must be checked or adjusted.

2 Statutory regulations governing installation

Guidelines	Thermo Top Evo
Heating Directive ECE R122	E1 00 0258
EMC Directive ECE R10	E1 04 5627

Note

The regulations of these guidelines are binding in the scope of the Directive 70/156/EEC and/or 2007/46/EC (for new vehicle models from 29/04/2009) and should also be observed in countries in which there are no special regulations.

Important

Failure to follow the installation instructions will result in the invalidation of the type approval for the heater and therefore invalidation of the general **homologation of the vehicle**.

Note

The heater is licensed in accordance with paragraph 19, section 3, No. 2b of the StVZO (German Road Traffic Licensing Authority).

2.1 Excerpt from ECE regulation 122 (heating system) paragraph 5 for the installation of the heater

Beginning of excerpt.

ANNEX VII

REQUIREMENTS FOR COMBUSTION HEATERS AND THEIR INSTALLATION

1. GENERAL REQUIREMENTS

1.7.1. A clearly visible tell-tale in the operator's field of view shall inform when the combustion heater is switched on or off.

2. VEHICLE INSTALLATION REQUIREMENTS

2.1. Scope

2.1.1. Subject to paragraph 2.1.2, combustion heaters shall be installed according to the requirements of this Annex.

2.1.2. Vehicles of category O having liquid fuel heaters are deemed to comply with the requirements of this Annex.

2.2. Positioning of heater

2.2.1. Body sections and any other components in the vicinity of the heater must be protected from excessive heat and the possibility of fuel or oil contamination.

2.2.2. The combustion heater shall not constitute a risk of fire, even in the case of overheating. This requirement shall be deemed to be fulfilled if the installation ensures an adequate distance to all parts and suitable ventilation, by the use of fire resistant materials or by the use of heat shields.

2.2.3. In the case of M2 and M3 vehicles, the heater must not be positioned in the passenger compartment. However, an installation in an effectively sealed envelope which also complies with the conditions in paragraph 2.2.2 may be used.

2.2.4. The label referred to in paragraph 1.4 or a duplicate, must be positioned so that it can be easily read when the heater is installed in the vehicle.

2.2.5. Every reasonable precaution should be taken in positioning the heater to minimise the risk of injury and damage to personal property.

2.3. Fuel supply

2.3.1. The fuel filler must not be situated in the passenger compartment and must be provided with an effective cap to prevent fuel spillage.

2.3.2. In the case of liquid fuel heaters, where a supply separate to that of the vehicle is provided, the type of fuel and its filler point must be clearly labelled.

2.3.3. A notice, indicating that the heater must be shut down before refuelling, must be affixed to the fuelling point. In addition a suitable instruction must be included in the manufacturer's operating manual.

2.4. Exhaust system

2.4.1. The exhaust outlet must be located so as to prevent emissions from entering the vehicle through ventilators, heated air inlets or opening windows.

2.5. Combustion air inlet

2.5.1. The air for the combustion chamber of the heater must not be drawn from the passenger compartment of the vehicle.

2.5.2. The air inlet must be so positioned or guarded that blocking by rubbish or luggage is unlikely.

2.6. Heating air inlet

2.6.1. The heating air supply may be fresh or recirculated air and must be drawn from a clean area not likely to be contaminated by exhaust fumes emitted either by the propulsion engine, the combustion heater or any other vehicle source.

2.6.2. The inlet duct must be protected by mesh or other suitable means.

2.7. Heating air outlet

2.7.1. Any ducting used to route the hot air through the vehicle must be so positioned or protected that no injury or damage could be caused if it were to be touched.

2.7.2. The air outlet must be so positioned or guarded that blocking by rubbish or luggage is unlikely.

End of excerpt.

In multilingual versions the German language is binding.

Renault Scenic

Information on Validity

This installation documentation applies to Renault Scenic Diesel vehicles - for validity, see page 1 - from model year 2017 and later, assuming technical modifications to the vehicle do not affect installation, any liability claims excluded. Depending on the vehicle version and equipment, modifications may be necessary during installation with respect to this installation documentation.

Vehicle and engine types, equipment variants and other specifications not listed in this installation documentation have not been tested. However, installation according to this installation documentation may be possible.

Technical Information

Special Tools

- Hose clamp pliers for auto-tightening hose clamps
- Hose clamp pliers for Clic hose clamps of type W
- Automatic wire stripper, 0.2 - 6mm²
- Crimping pliers for cable lug / tab connector, 0.5 - 6mm²
- Torque wrench for 2.0 - 10 Nm
- Hose clamping pliers
- Metric thread-setter kit
- Deep-hole marker
- Webasto Thermo Test Diagnosis with current software

Dimensions

- All dimensions are in mm.

Tightening torque values

- Tightening torque values of 5x13 heater bolts and 5x11 heater stud bolts = 8Nm.
- Tightening torque value of 5x15 water connection piece retaining plate bolt = 7Nm.
- Tighten other bolt connections in accordance with manufacturer's instructions or in accordance with state-of-the-art technology.

Explanatory Notes on Document

You will find an identification mark on the outside top right corner of the page in question to provide you with a quick overview of the individual working steps.

Mechanics



Electrics



Coolant Circuit



Combustion Air

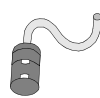

Fuel



Exhaust Gas



Software



Special features are highlighted using the following symbols:

Specific risk of damage to components.



Specific risk due to electrical voltage.



Specific risk of fire or explosion.



Reference to a special technical feature.



The arrow in the vehicle icon indicates the position on the vehicle and the viewing angle.

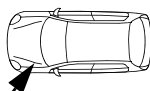

Reference to the manufacturer's vehicle-specific documents.



Reference to specific installation instructions of Webasto components (demonstrated with the example of the FuelFix).



Reference to general installation instructions of Webasto components.



Tightening torque according to the manufacturer's vehicle-specific documents.



Renault Scenic

Preliminary Work

Vehicle



- Open the fuel tank cap.
- Ventilate the fuel tank.
- Close the fuel tank cap again.
- Depressurise the cooling system.
- Disconnect and completely remove the battery together with the carrier.
- Completely remove the air filter.
- Detach the brake fluid reservoir with the filler neck and put this aside.
- Remove the coolant reservoir cap and coolant reservoir.
- Remove the wheel on the left.
- Remove the front wheel well trim on the left.
- Detach the front wheel well trim at the front on the right.
- Remove the front bumper trim in the engine compartment.
- Remove the lower engine cover.
- Remove the underride protection on the right.
- Remove the rear bench seat in the middle and on the right side.
- Open the right-hand tank-fitting service lid.
- Remove the lower instrument panel trim on the left side.
- Remove the door sill trim on the left side.
- Remove the lower A-pillar trim on the left side.

Heater

- Remove years that do not apply from the type and duplicate label.
- Attach the duplicate label (type label) visibly in the appropriate place in the engine compartment.

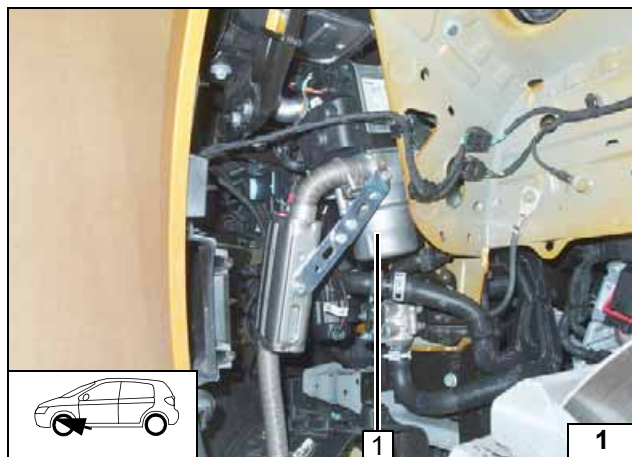

Heater Installation Location

- 1 Heater

Installation location

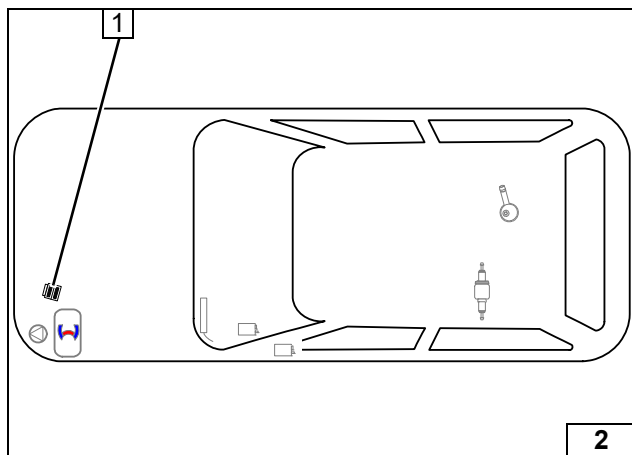

Preparing Electrical System

- 1 Engine compartment fuse holder



Installation overview

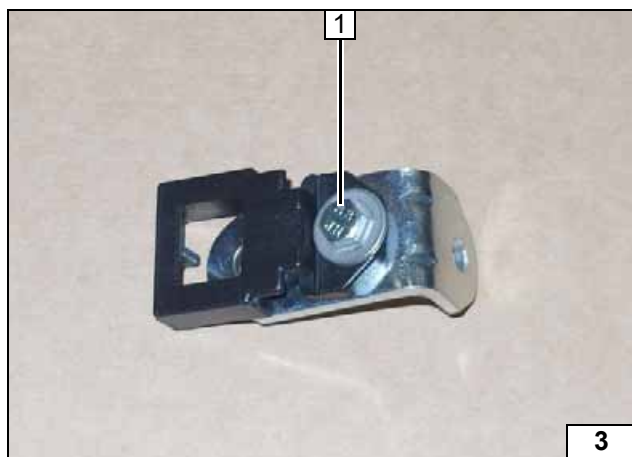

- 1 M5x16 bolt, large diameter washer, engine compartment fuse holder retaining plate, angle bracket, large diameter washer, nut

Preparing fuse holder of engine compartment

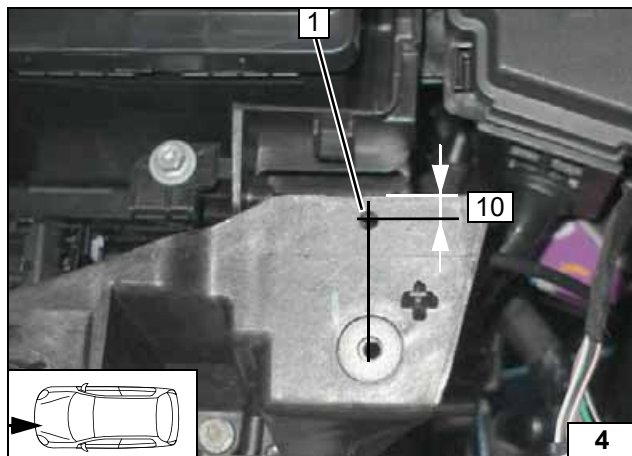

- 1 Copy hole pattern, 7mm dia. hole

Hole for fuse holder

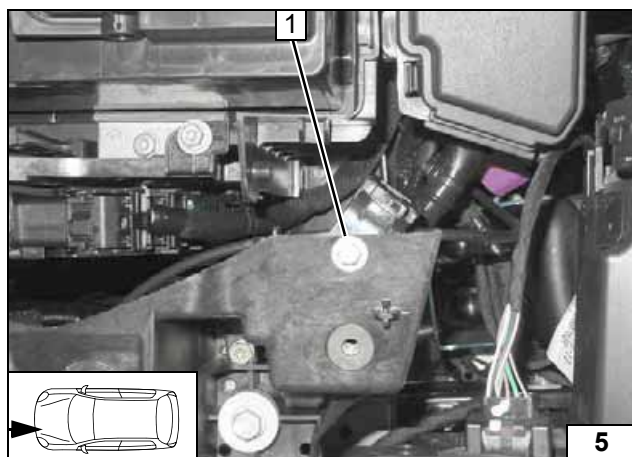

- 1 M6x20 bolt, large diameter washer, flanged nut

Installing retaining plate of engine compartment fuse holder



Electrical System



Earth wire

- 1 Earth wire on original vehicle earth support point

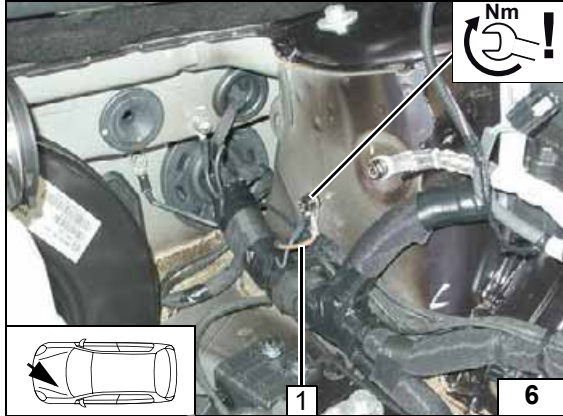

Cable pass through

- 1 Protective rubber plug
- 2 Heater wiring harnesses, heater control

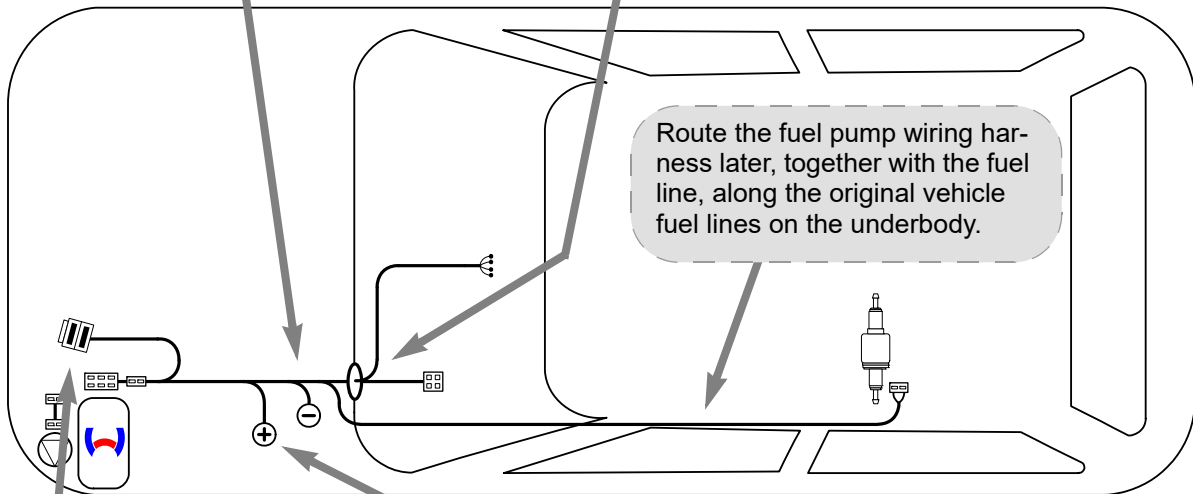
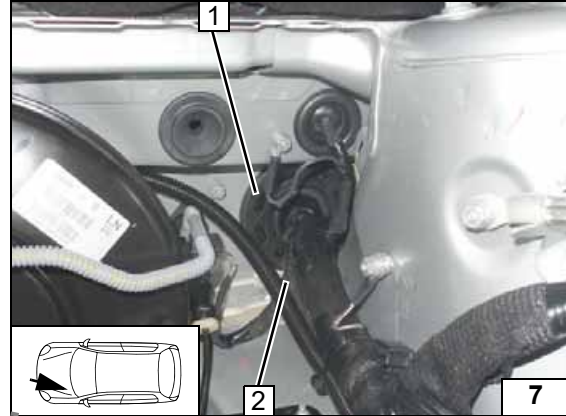

Wiring harness routing diagram

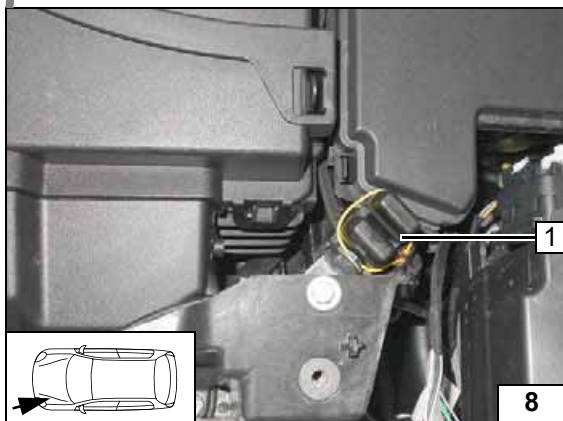

Engine compartment fuse holder

- 1 Fuses F1-2

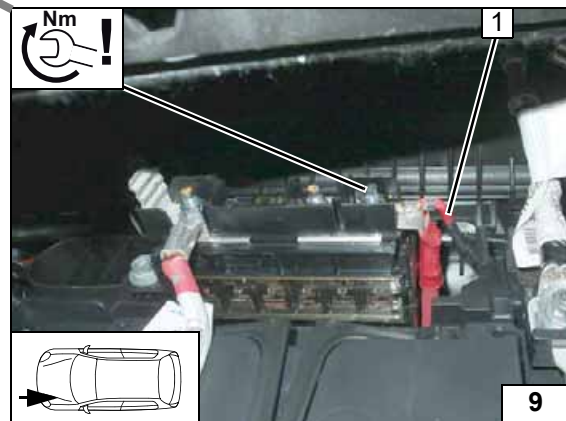

Positive wire

- 1 Positive wire on original vehicle positive support point





Air-Conditioning Control

! Integrate the A/C control as explained in the separate installation documentation:

Installation documentation of '**Webasto Standard**' A/C control for Renault Espace / Scenic

or

Installation documentation of '**Webasto Comfort**' A/C control for Espace / Scenic

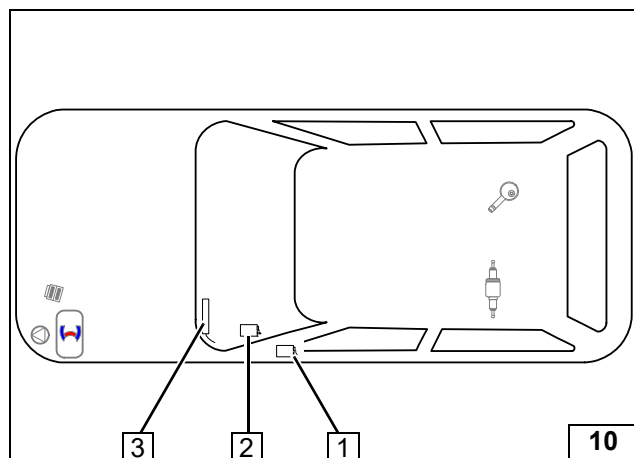

Heater Control Installation

- 1 ThermoCall receiver
- 2 Telestart receiver
- 3 Telestart / ThermoCall aerial



Installation overview

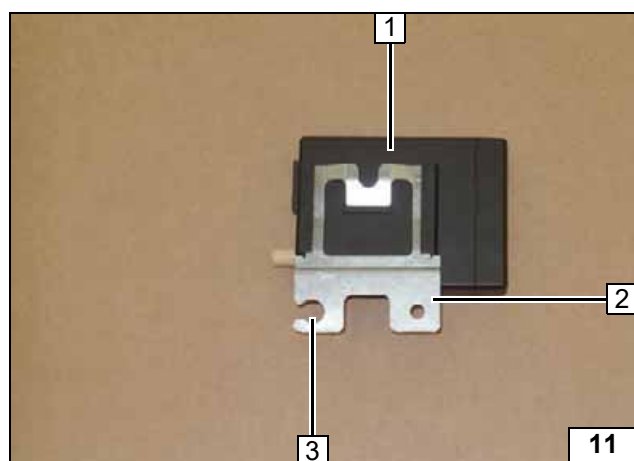

Remote Option (Telestart)

- 1 Receiver
- 2 Bracket
- 3 8.5 mm dia. hole



Preparing receiver

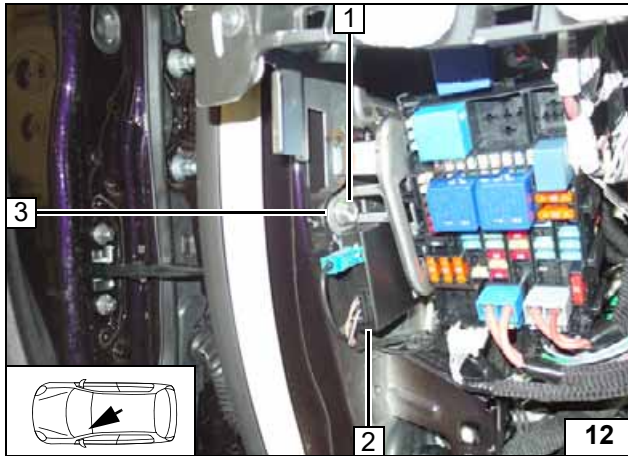

Remove original vehicle bolt **1**.
Place Telestart bracket between vehicle and original vehicle retaining plate at position **3** and secure using original vehicle bolt.



2 Receiver

Installing receiver

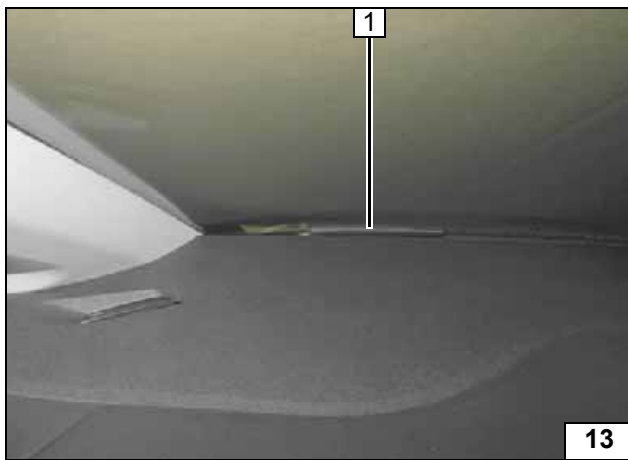

1 Aerial



Installing aerial

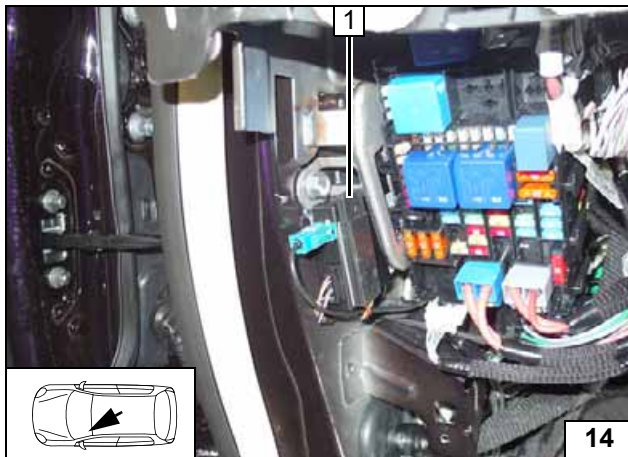

Temperature sensor T100 HTM

Fasten temperature sensor **1** with double-sided adhesive tape



Installing temperature sensor



ThermoCall Option

Carefully remove the mounting tab on the receiver.

1 Receiver

X =



Preparing receiver

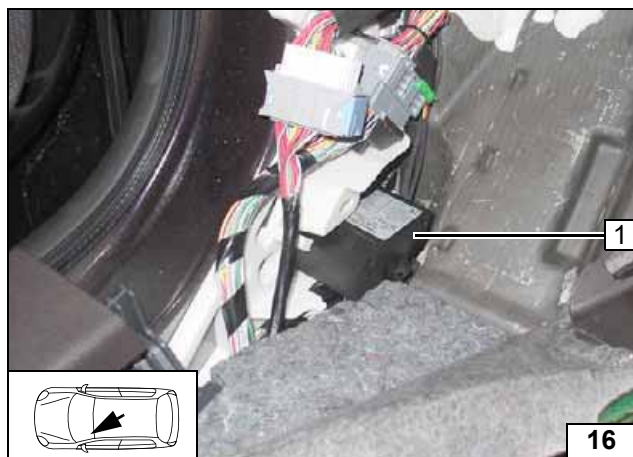

Fasten receiver 1 in line duct using double-sided adhesive tape.



Installing receiver

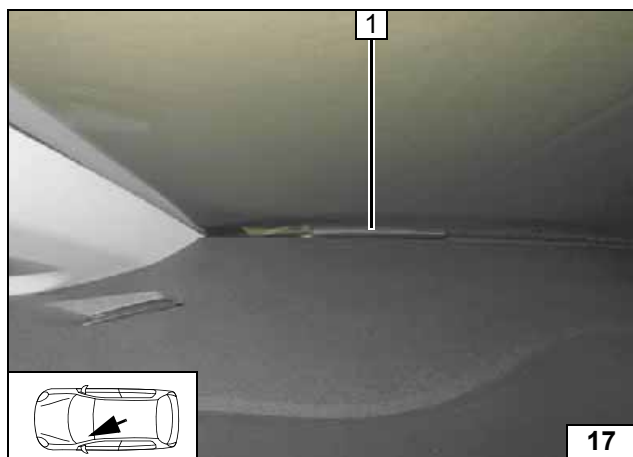

1 Aerial (optional)

Installing aerial

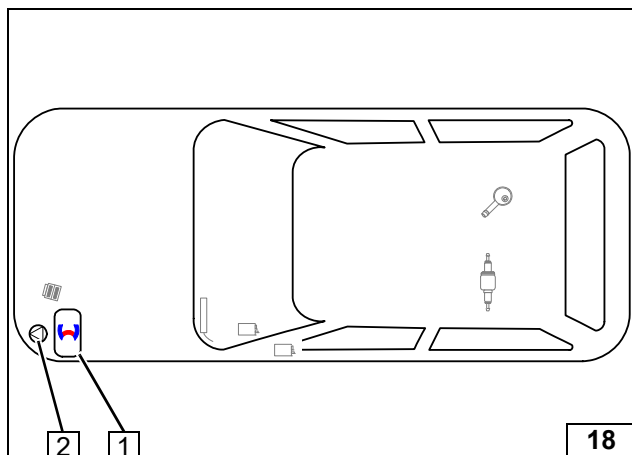

Preparing Installation Location

- 1 Heater
- 2 Coolant pump



Installation overview

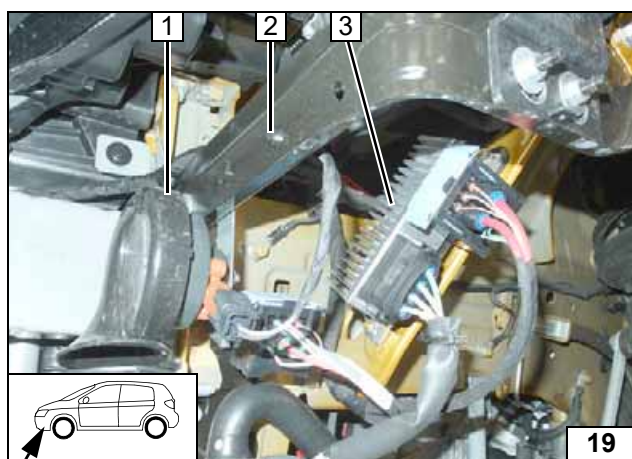

Detach original vehicle clip-type cable tie 2 and discard.

- 1 Horn with bracket
- 3 Auxiliary heater control unit



Removing horn and auxiliary heater control unit

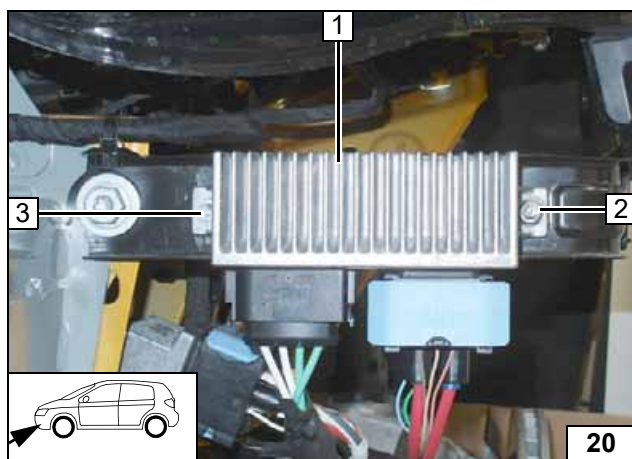

- 1 Auxiliary heater control unit
- 2 M6x20 bolt, large diameter washer, original vehicle oblong hole, auxiliary heater control unit, flanged nut
- 3 Copy hole pattern

Preparing auxiliary heater control unit

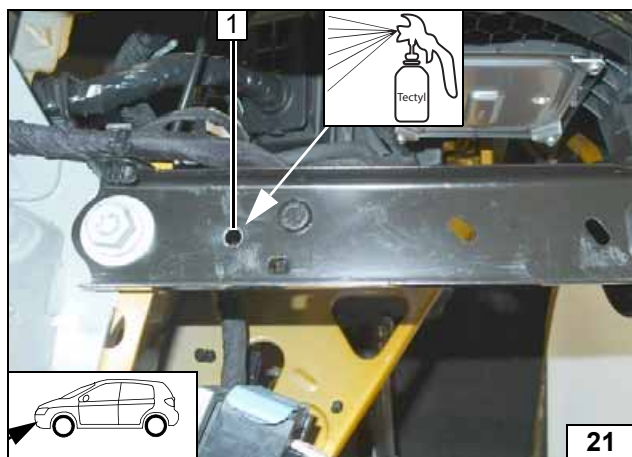

- 1 7 mm dia. hole

Drilling hole

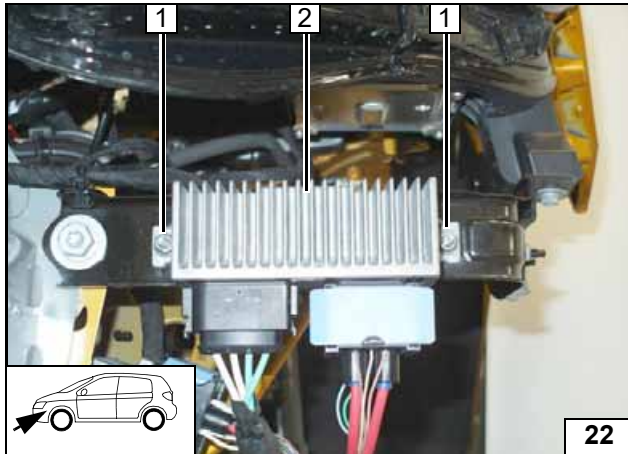
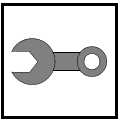

- 1 M6x20 bolt, large diameter washer, hole, auxiliary heater control unit, flanged nut
- 2 Auxiliary heater control unit

Installing auxiliary heater control unit

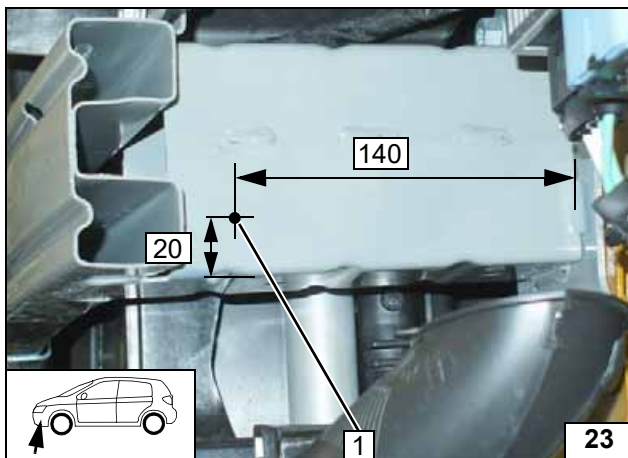

- 1 Copy hole pattern

Preparing horn installation

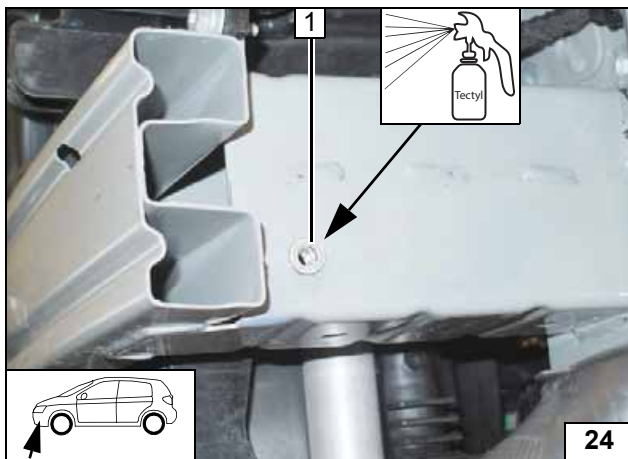

- 1 9mm dia. hole, rivet nut

Installing rivet nut

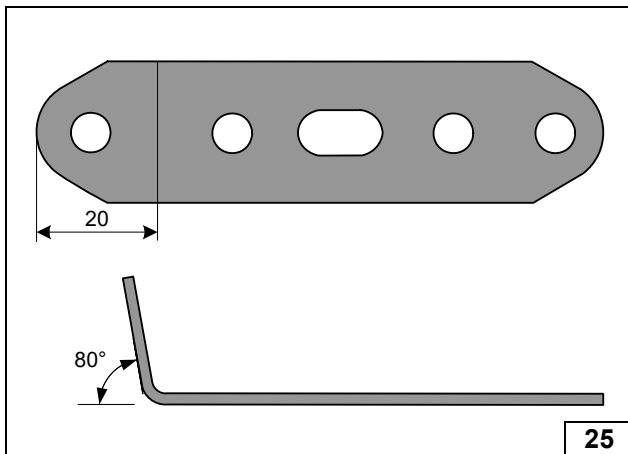

Preparing perforated bracket

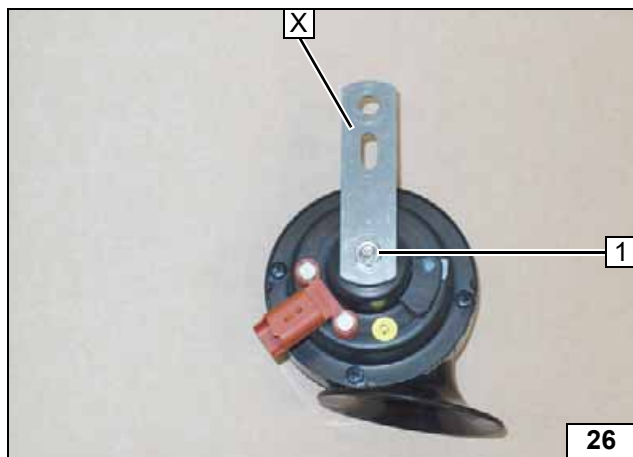
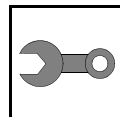

1 Original vehicle nut will be reused

X =

Preparing horn

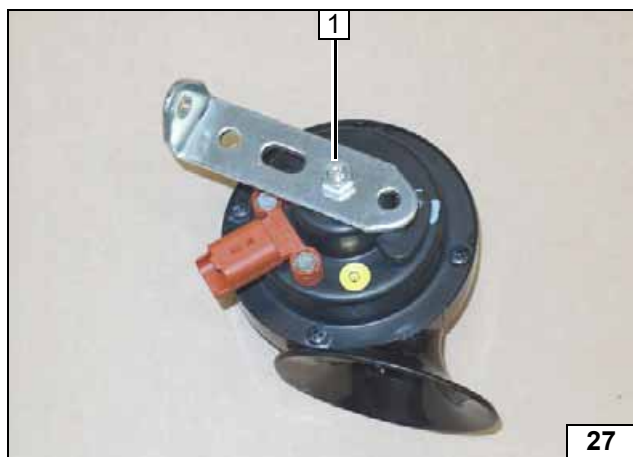

1 Mount horn, perforated bracket, original vehicle nut loosely

Installing horn

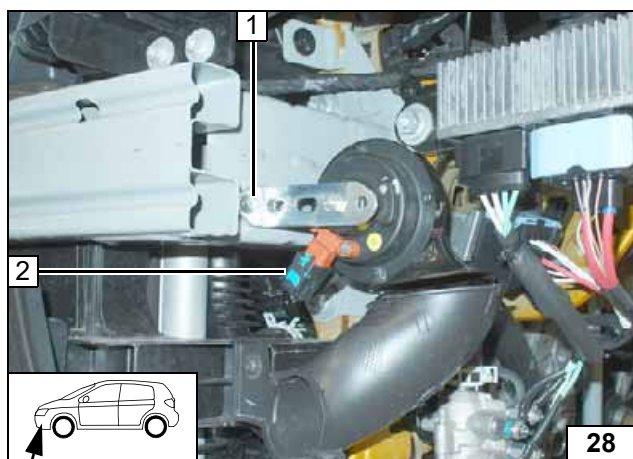

Align horn as shown and secure.

- 1 M6x20 bolt, spring lockwasher
- 2 Horn connector



Installing horn

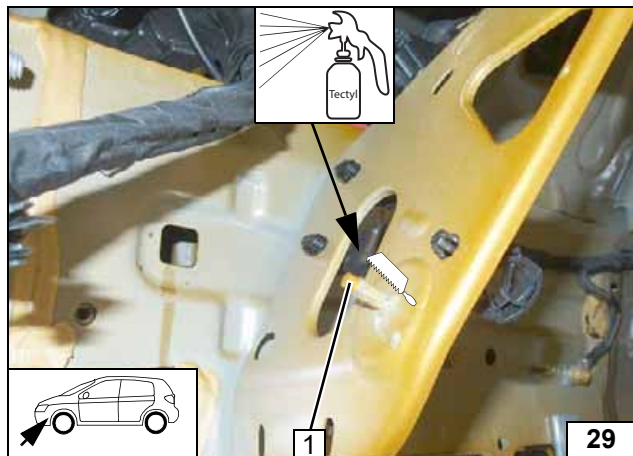

1 Original vehicle stud bolt

Removing stud bolt

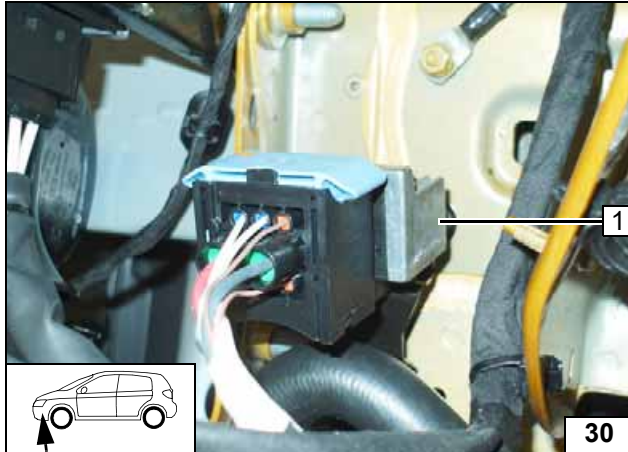
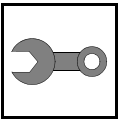

1 Original vehicle relay

Removing original vehicle relay

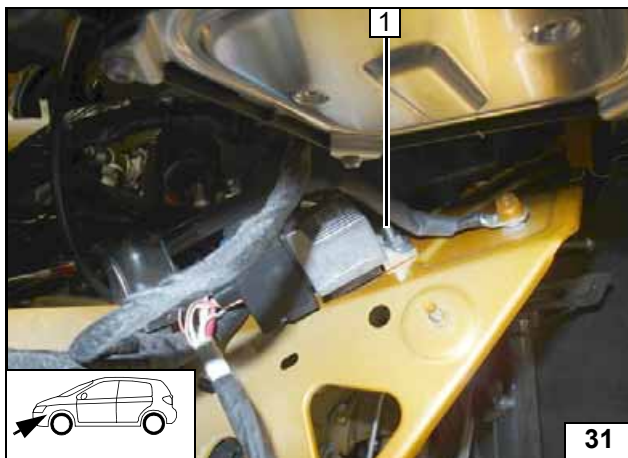

1 M6x20 bolt, large diameter washer, original vehicle hole, original vehicle relay, flanged nut

Installing original vehicle relay

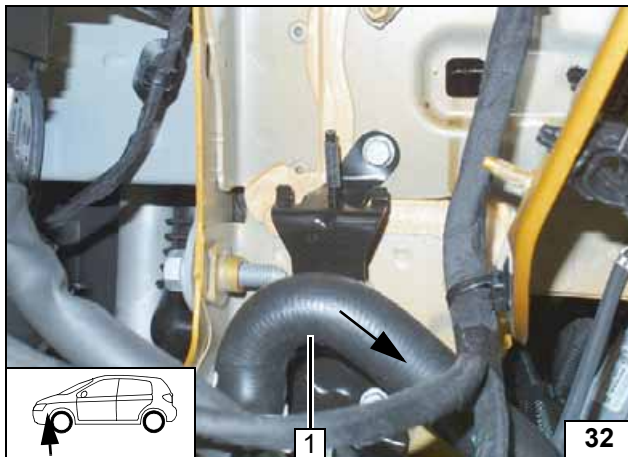

Dismantle hose of engine inlet 1 at auxiliary heater outlet and put it aside. Original vehicle spring clip will be reused.



Dismantling hose

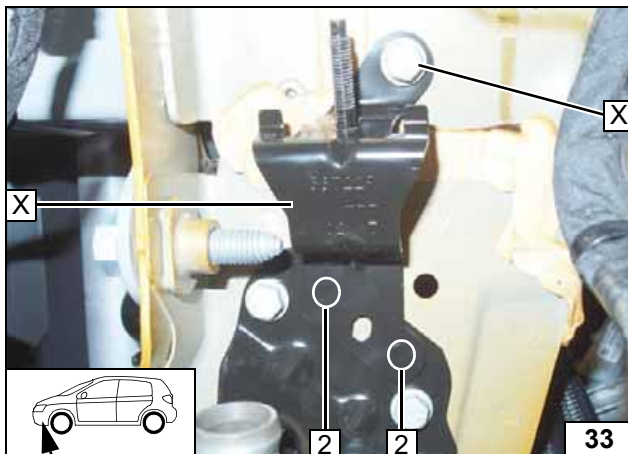

Drill open original vehicle welding spot 2.

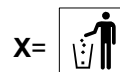

Shortening original vehicle bracket

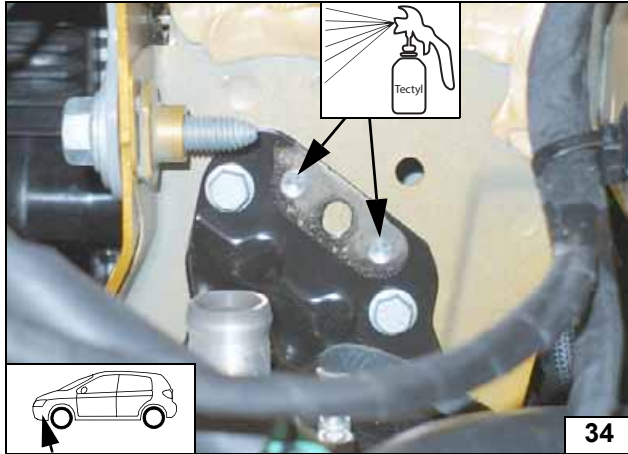
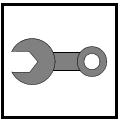

Applying corrosion protection

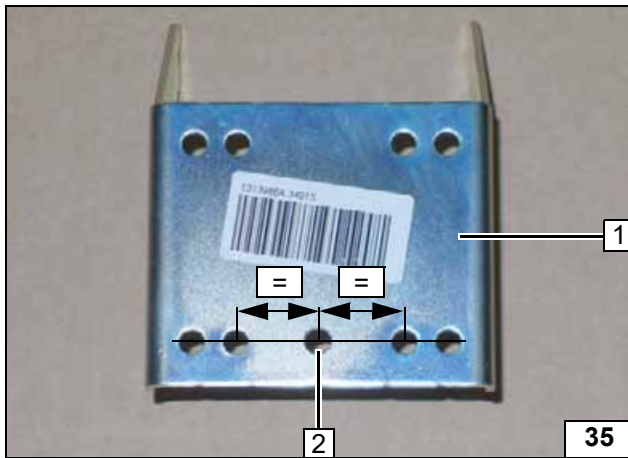

Preparing Bracket

- 1 Bracket
- 2 Copy hole pattern, 7mm dia. hole

Preparing bracket

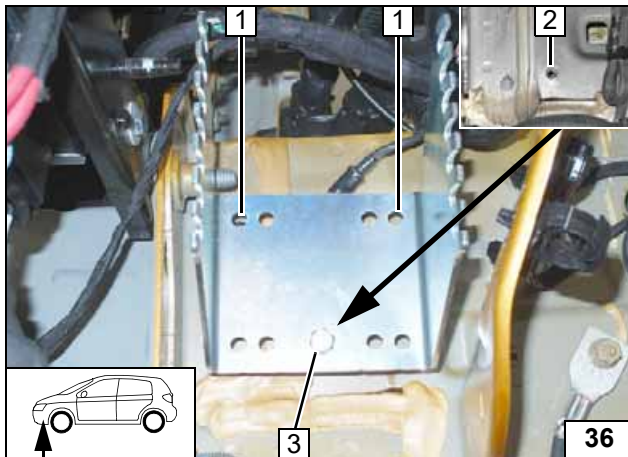

- 1 Copy hole pattern
- 2 Original vehicle thread
- 3 M6x40 bolt, spring lockwasher, 20mm spacer

Copying hole pattern

Remove bracket.

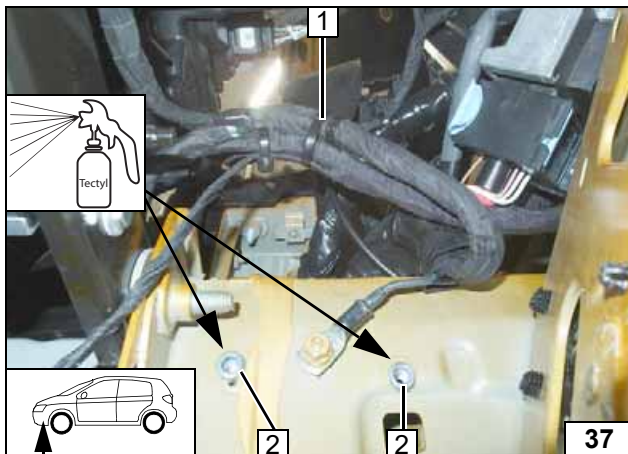

Fasten original vehicle wiring harnesses with cable ties as shown.

- 2 9mm dia. hole; rivet nut

Installing rivet nut



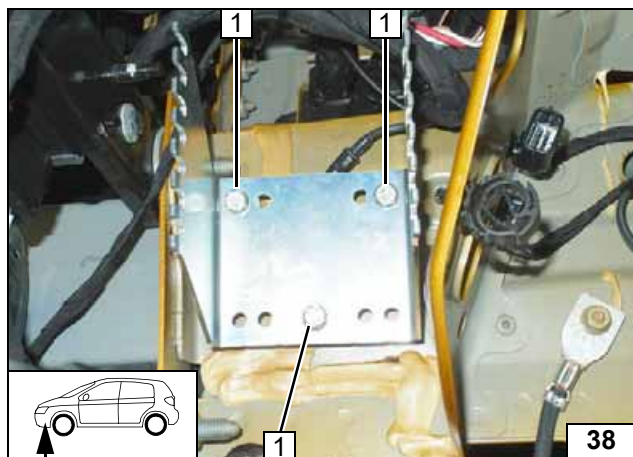
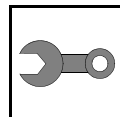

- 1 M6x40 bolt, spring lockwasher, 20mm spacer

Installing bracket

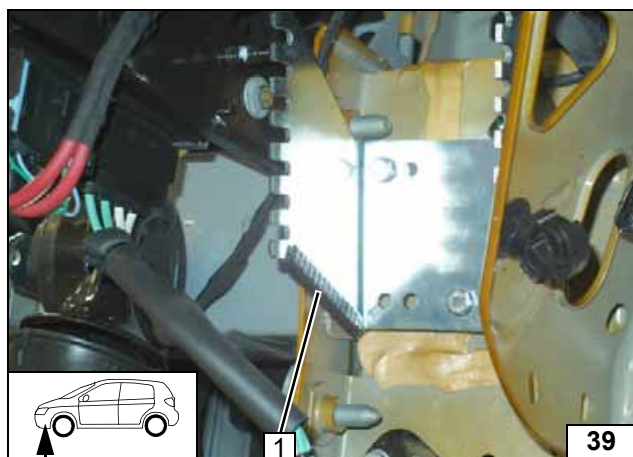

- 1 Edge protection, 70 mm long

Installing edge protection

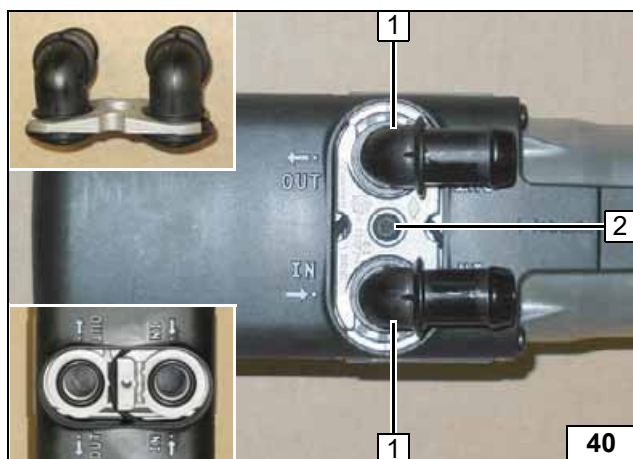

Preparing Heater

- 1 Water connection piece, sealing ring
- 2 5x15 self-tapping bolt, retaining plate of water connection piece



Installing water connection piece

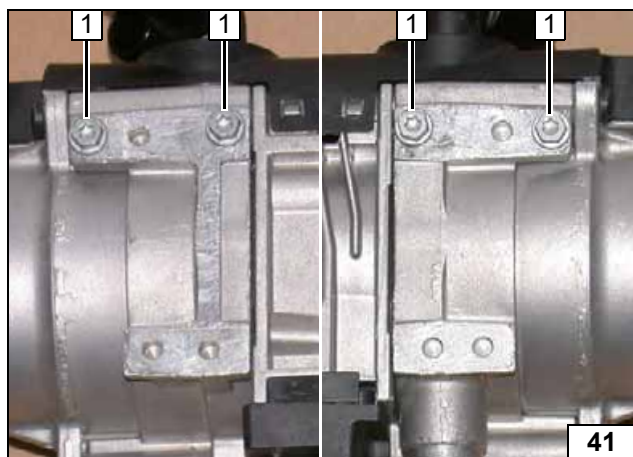

Screw 5x13 self-tapping bolts 1 into existing holes by a maximum of 3 thread turns.



Premounting bolts loosely

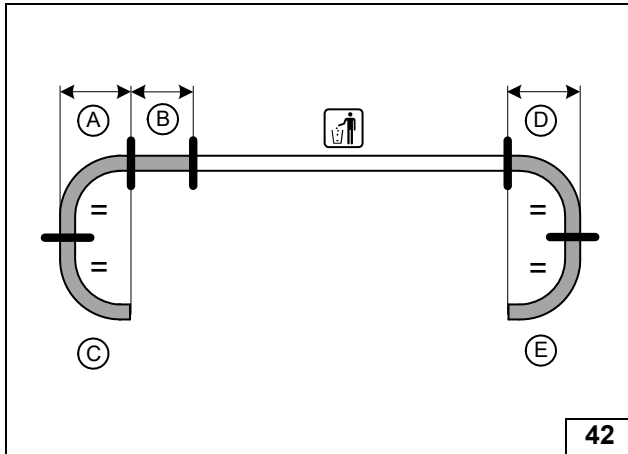
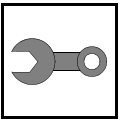

- A = 70
- B = 90
- C = 70
- D = 70
- E = 70

Cutting hoses to length

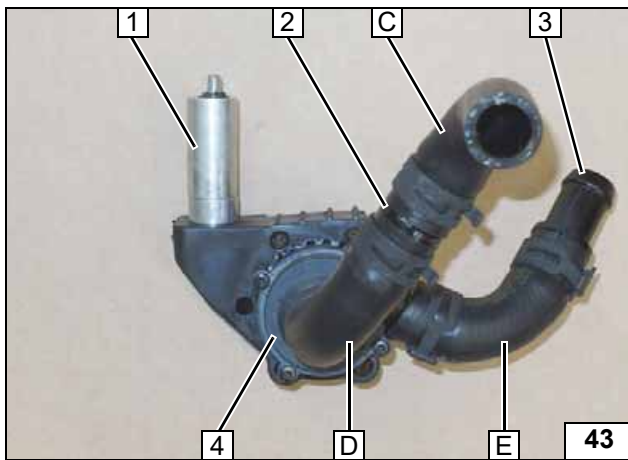

All spring clips 25 mm dia.
Mount hoses **D** and **E** with the short leg on the coolant pump.
Mount hose **C** with the short leg on the 18x18 connecting pipe.



Premounting coolant pump

- 1 M6x70 bolt, coolant pump mount, 10mm spacer, 40mm spacer, lock washer
- 2 18x18 connecting pipe
- 3 18x20 connecting pipe
- 4 Coolant pump

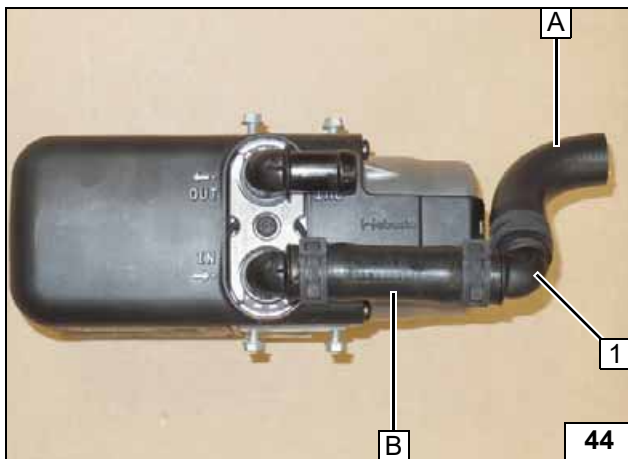

All spring clips 25 mm dia.
90° elbow **A** with long leg on 90° connecting pipe 18x18 **1**.



Premounting hoses A and B

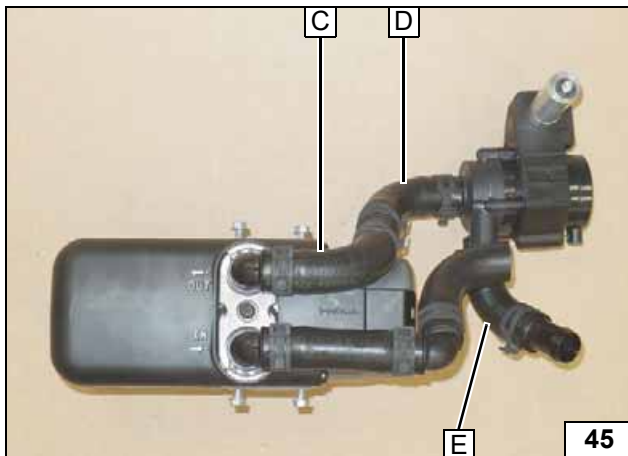

All spring clips 25 mm dia.



Mounting coolant pump

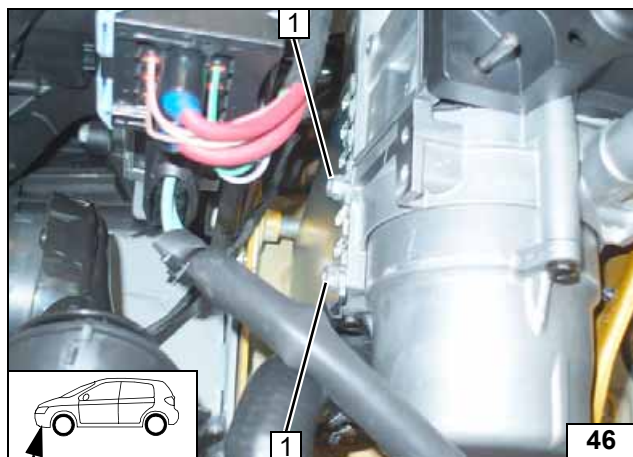
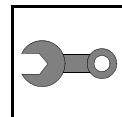

Installing Heater

- 1 Tighten 5x13 self-tapping bolt

Installing heater

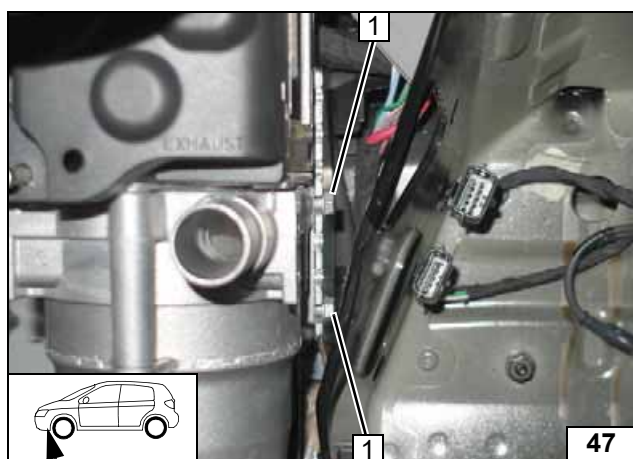

- 1 Tighten 5x13 self-tapping bolt

Installing heater

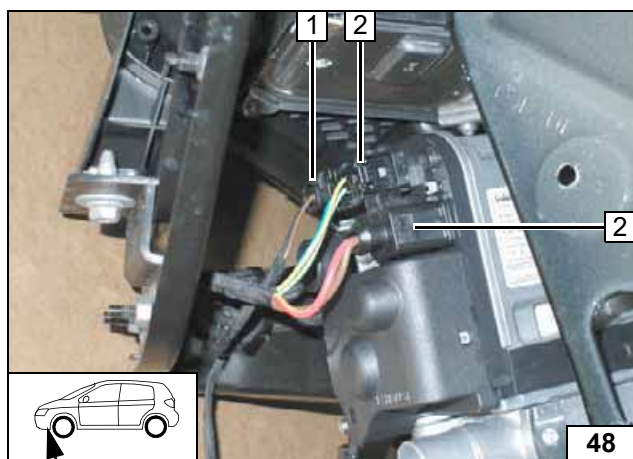

- 1 Connector of coolant pump wiring harness
- 2 Connector of heater wiring harness

Installing wiring harness of heater

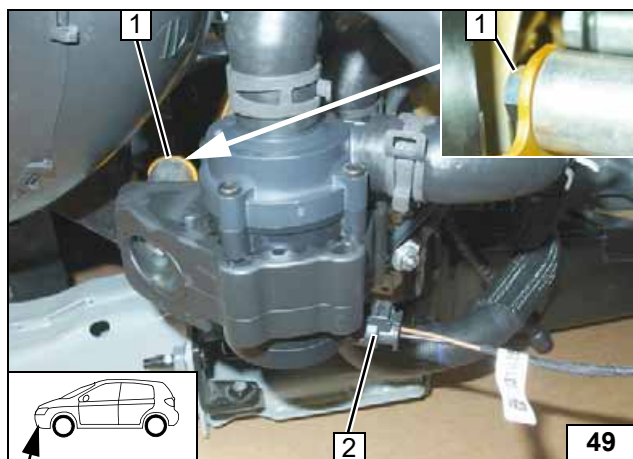

- 1 Premounted bolt, original vehicle hole, flanged nut
- 2 Connector of coolant pump wiring harness

Fastening coolant pump

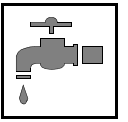

Coolant Circuit



Any coolant running off should be collected in an appropriate container. Route hoses kink-free. Unless specified otherwise, always fasten using cable ties. Position clamps so that other hoses cannot be damaged. The heater must be filled with coolant when installing the hoses.

The connection should be modelled on an 'inline' circuit and based on the following diagram:

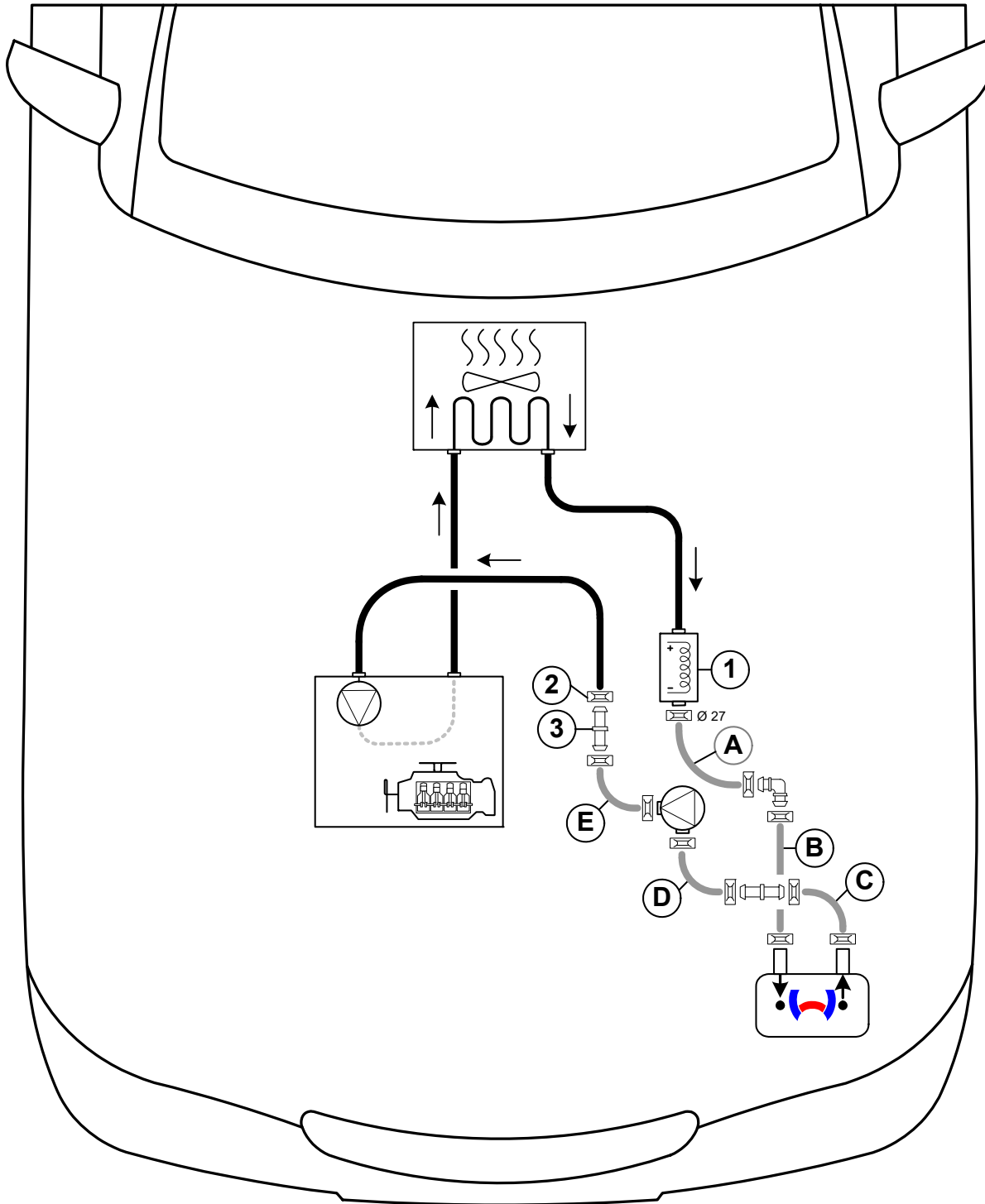

Hose routing diagram

- 1 = original vehicle auxiliary heater
- 2 = original vehicle spring clips
- 3 = original vehicle connecting pipe = 18x20mm dia.
- All spring clips without a specific designation = 25 mm dia. = 25mm dia.
- All connecting pipes without a specific designation and = 18x18mm dia.



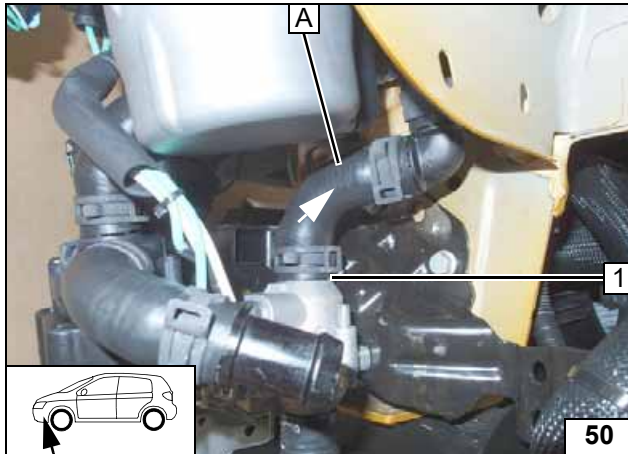

1 Auxiliary heater outlet connection piece

Conne-
tion of hose
A

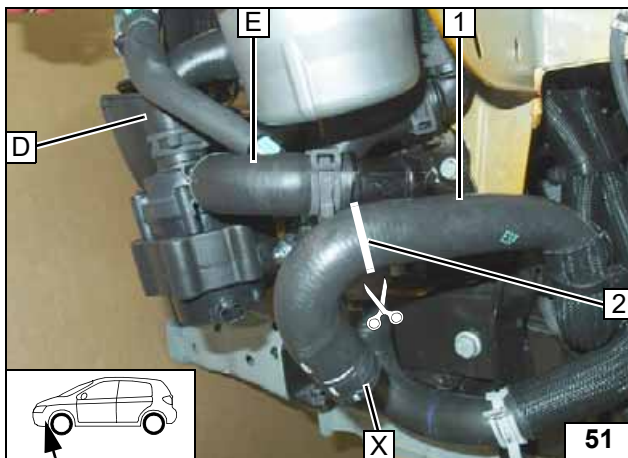

Position engine inlet hose 1 parallel with hose E as shown and copy cutting point 2.



X=

Cutting
point

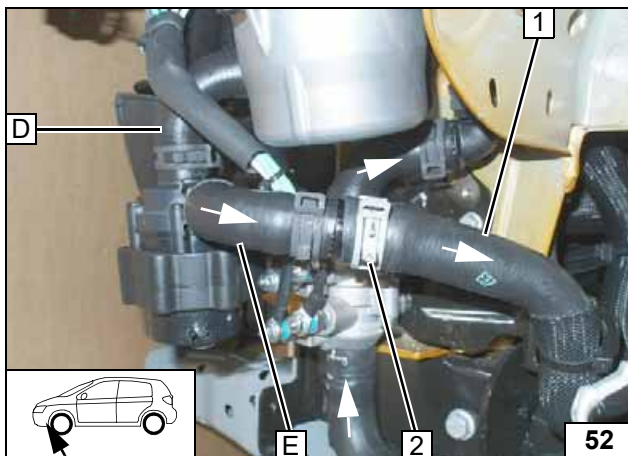

Align hoses. Ensure sufficient distance from neighbouring components, correct if necessary.



- 1 Engine inlet hose section
- 2 Original vehicle spring clip

Conne-
tion of hose
E



Fuel



Open the vehicle's fuel tank cap, ventilate the tank and then re-close the tank lock.

Catch any fuel running off in an appropriate container.



Route fuel line and fuel pump wiring harness so that they are protected against stone impact. Unless specified otherwise, always fasten using cable ties.

Provide rub protection for fuel line and wiring harness in areas where there are sharp edges.

The fuel line and wiring harness are routed to the fuel pump as shown in the wiring harness routing diagram.

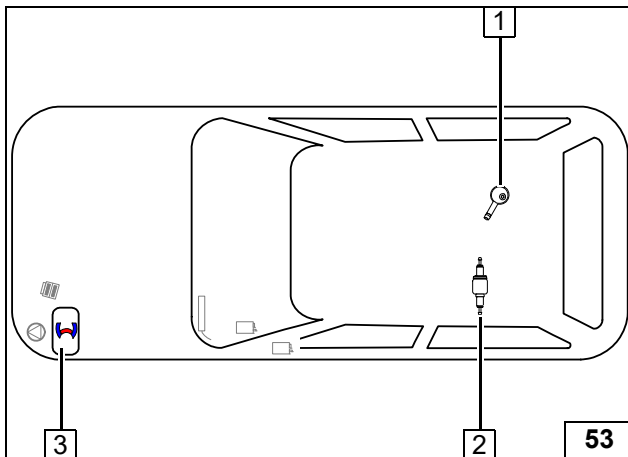

- 1 FuelFix
- 2 Fuel pump
- 3 Heater

53

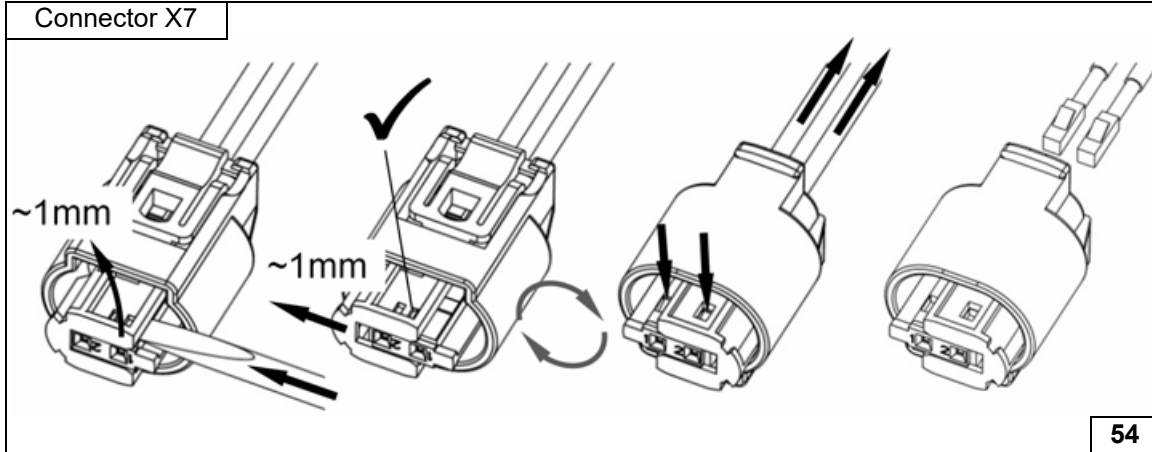

54

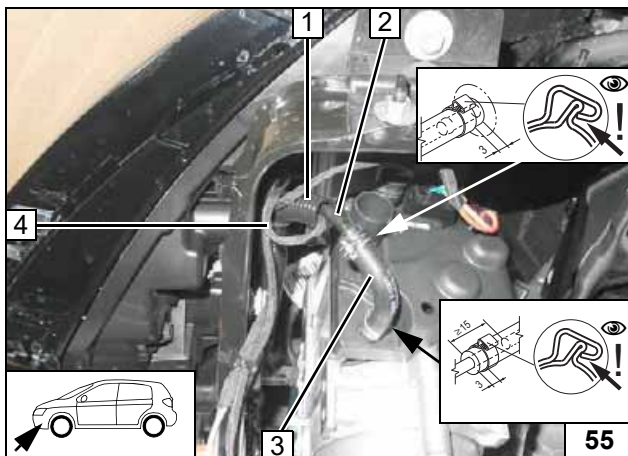

Pull fuel line 2 and fuel pump wiring harness 4 into corrugated tube 1 and route in the engine compartment.

- 3 90° moulded hose, 10mm dia. clamp [2x]

55



Installation overview

Dismantling fuel pump connector



Connecting heater



Route corrugated tube with fuel line and fuel pump wiring harness to the underbody.

Routing lines

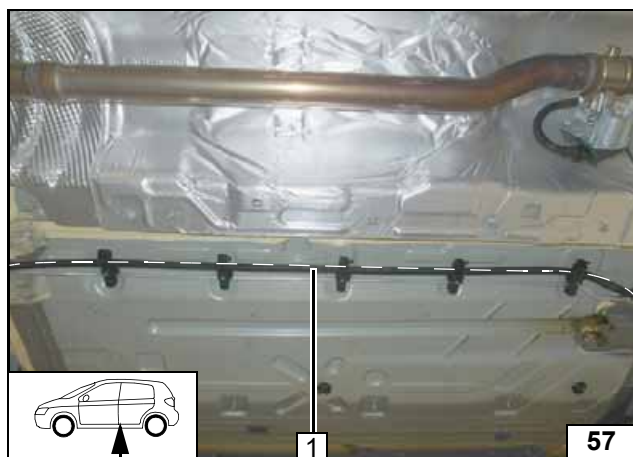

1 Route corrugated tube with fuel line and fuel pump wiring harness to the installation location of the fuel pump.

Routing lines

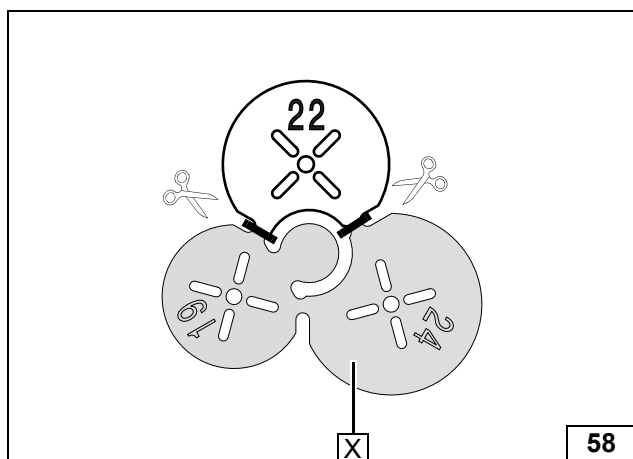

Installing FuelFix

x =

Preparing drilling template

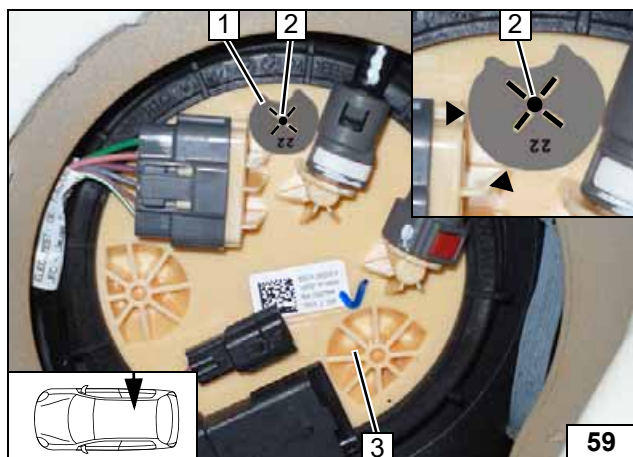

Work steps F1 and F2.

- 1 Position 22mm dia. drilling template at the marking
- 2 Copy hole pattern
- 3 Fuel tank sending unit



Copying hole pattern

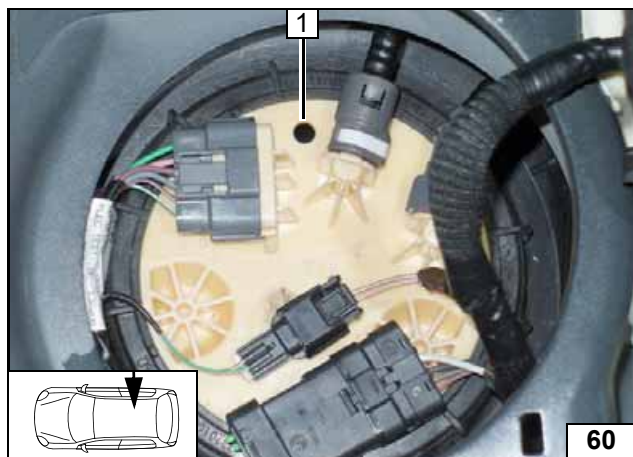

Work step F3.

1 Hole made with provided drill

Hole for FuelFix

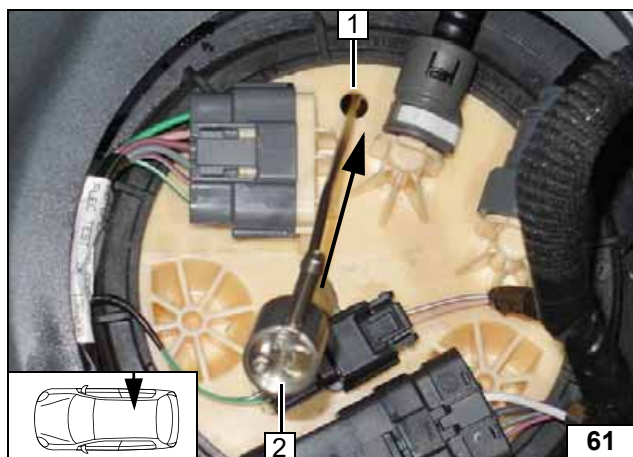

Work steps F4 and F5.

Bend FuelFix 2 according to template and cut to length. Insert into hole 1.



Inserting FuelFix

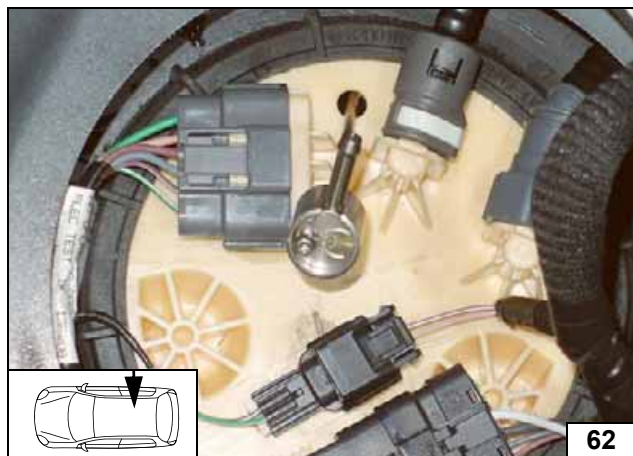

Work step F5.

Inserting FuelFix

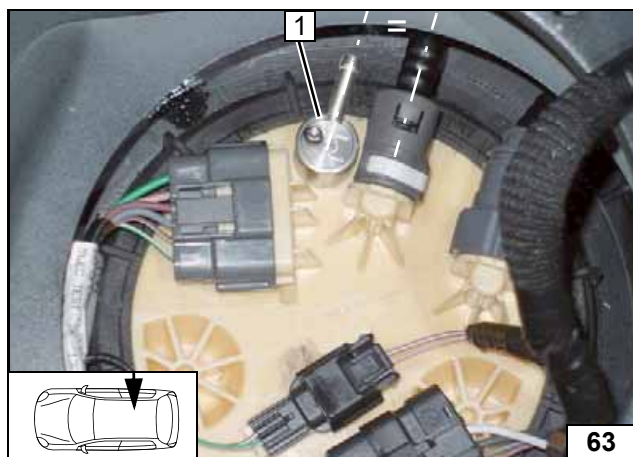

Work steps F5.3 and F5.4.

Align FuelFix 1 as shown.



Aligning FuelFix

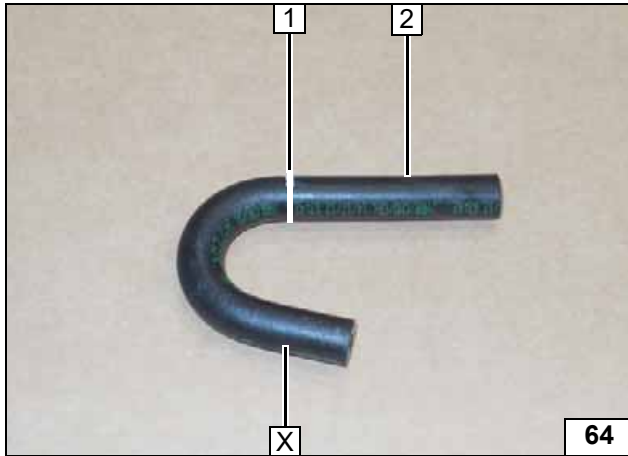
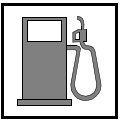

- 1 Cutting point
- 2 Hose section

X =

Cutting moulded hose to length

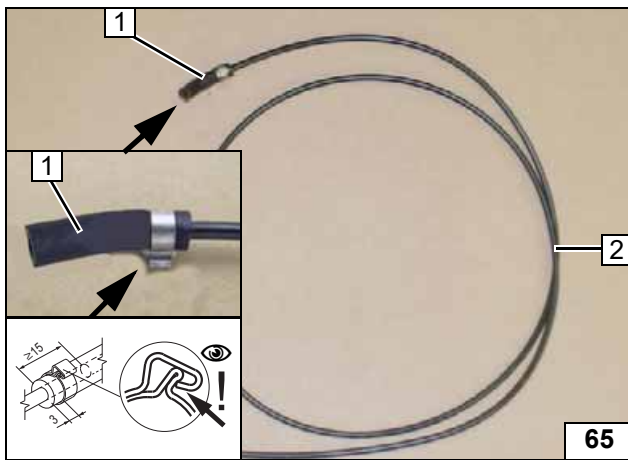

- 1 Shortened hose section, 10mm dia. clamp
- 2 1500 mm long fuel line

Preparing fuel line

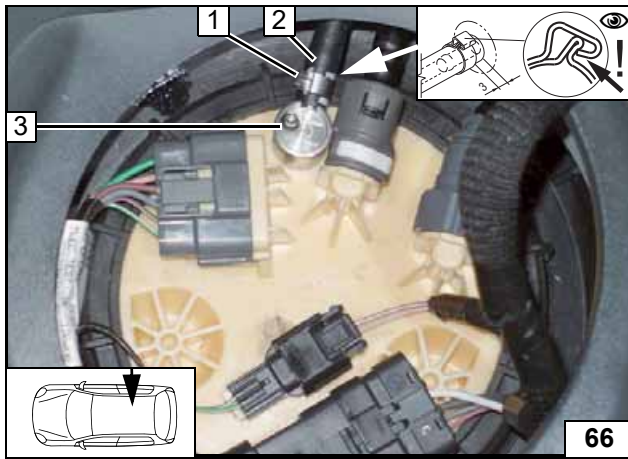

Work step F6.

- 1 10mm dia. clamp
- 2 Prepared fuel line
- 3 FuelFix

Connecting fuel line

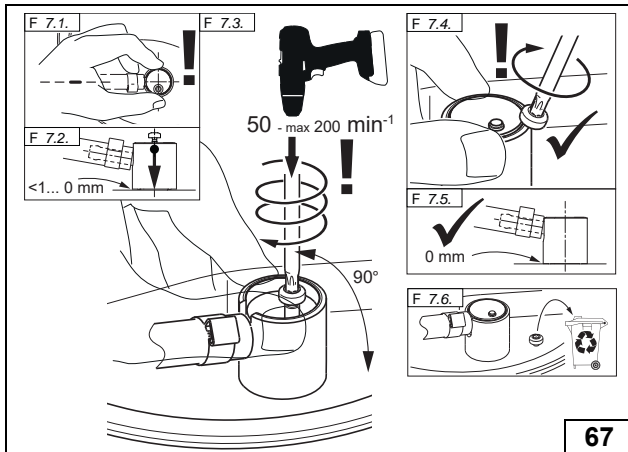

Work step F7.



Installing FuelFix

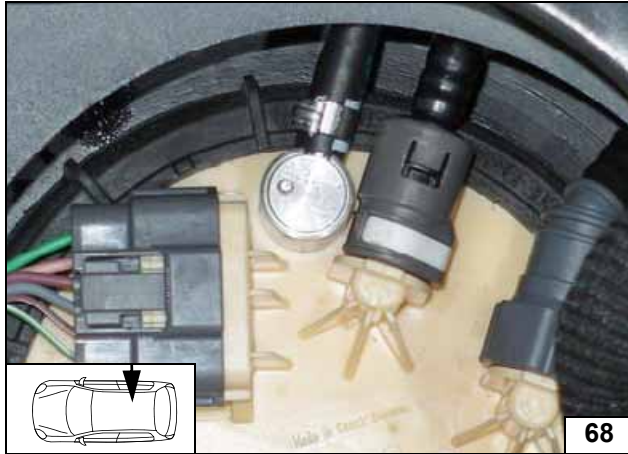
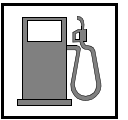

Work step F8.

Ensuring firm seating of FuelFix

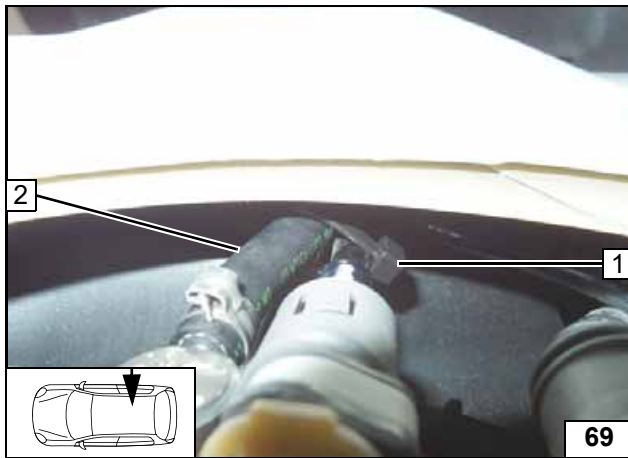

- 1 Cable tie as tension relief
- 2 Fuel line of FuelFix

Securing fuel line

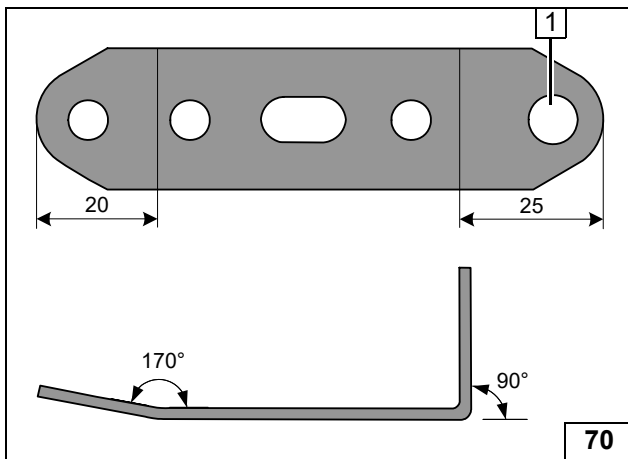

- 1 Drill out hole to 8.5 mm dia.

Preparing perforated bracket

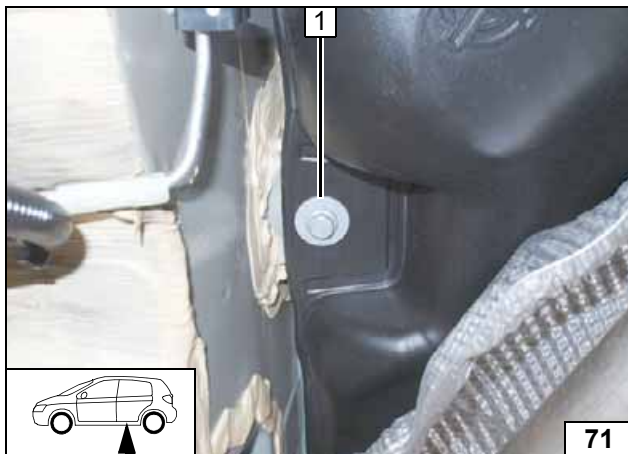

- 1 Original vehicle bolt

Removing original vehicle bolt

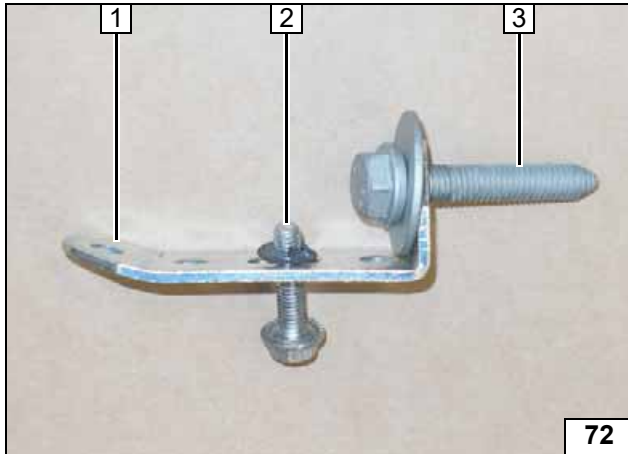

- 1 Perforated bracket
- 2 M6x25 bolt, lock washer
- 3 Original vehicle bolt

Premounting perforated bracket

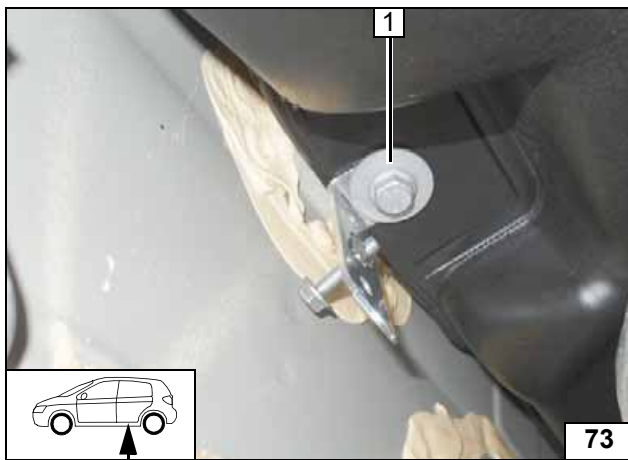

- 1 Original vehicle bolt with washer, perforated bracket

Installing perforated bracket

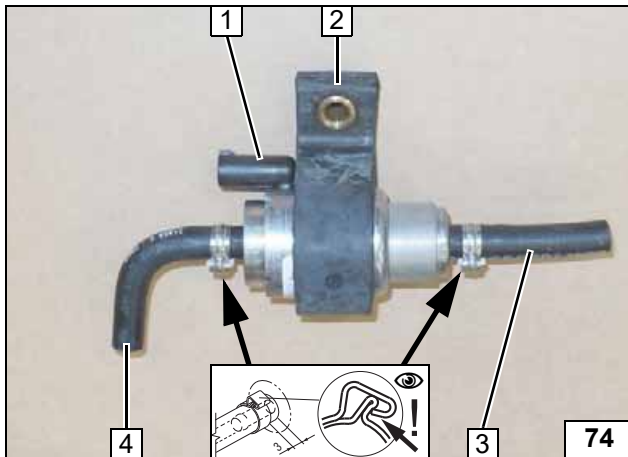

- 1 Fuel pump
- 2 Fuel pump mount, support angle bracket, flanged nut
- 3 Hose section, 10mm dia. clamp
- 4 90° moulded hose, 10 mm dia. clamp

Installing fuel pump mount

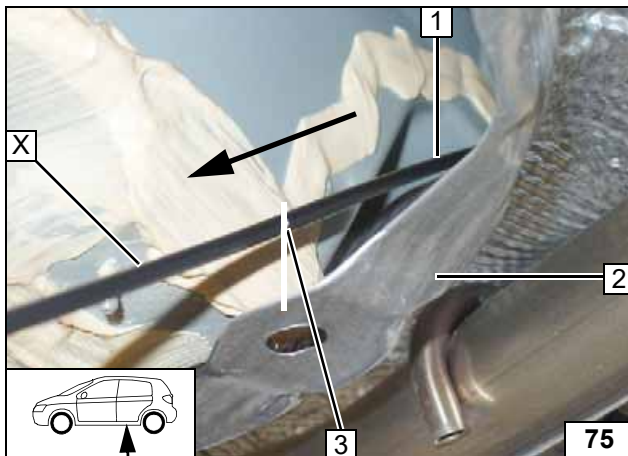

Pull the FuelFix fuel line 1 in the direction of the arrow and cut it on heat shield plate 2 side.



- 3 Cutting point

X =

Cutting FuelFix fuel line to length

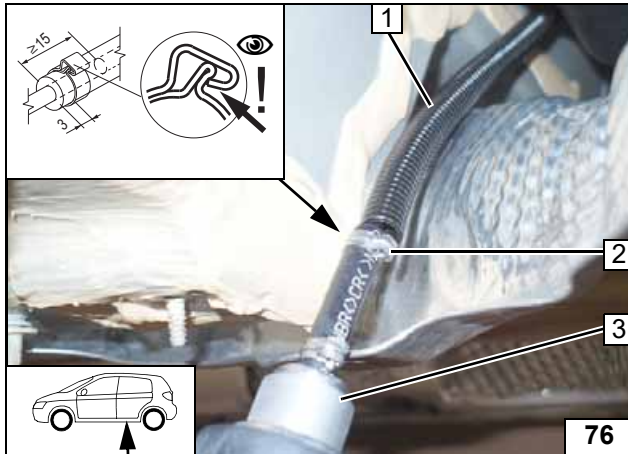

- 1 Fuel line in corrugated tube
- 2 10 mm dia. clamp
- 3 Fuel pump

**Connect-
ing fuel
pump**

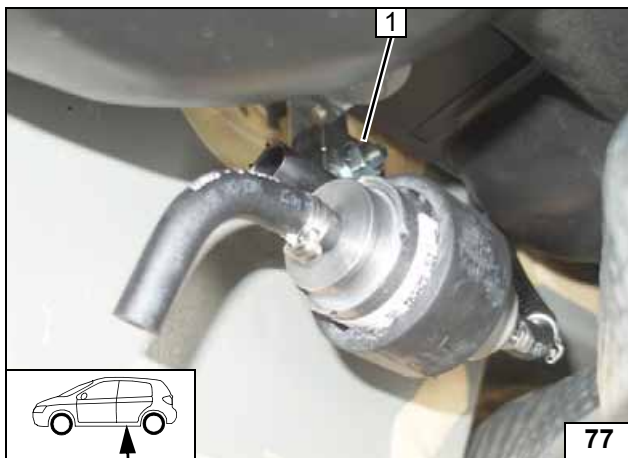

Ensure sufficient distance from neighbouring components, correct if necessary.



- 1 Premounted bolt, fuel pump mount, support angle bracket, flanged nut

**Installing
fuel pump**

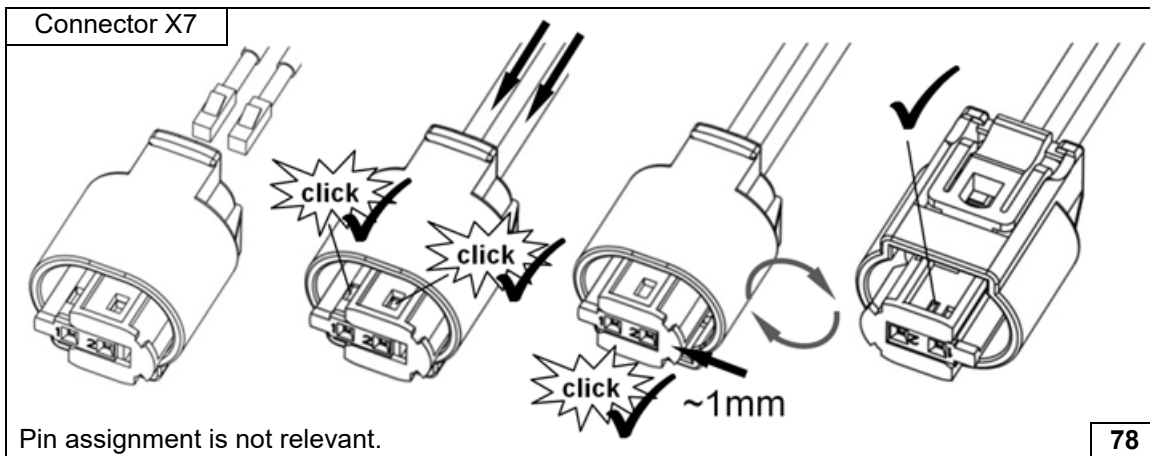

**Completing
fuel pump
connector**

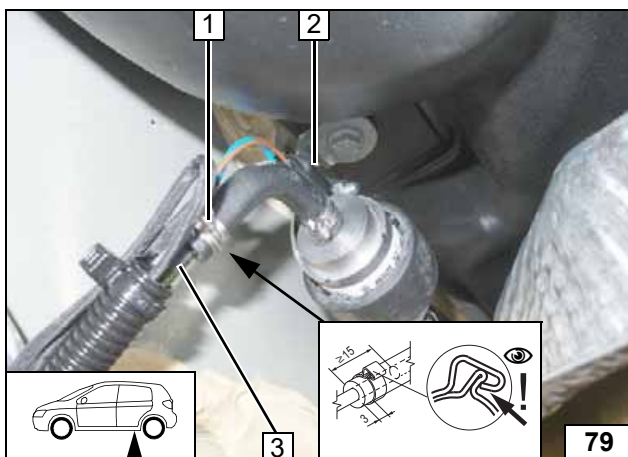

- 1 10 mm dia. clamp
- 2 Fuel pump wiring harness, connector X7 mounted
- 3 Fuel line of heater



**Connec-
tion of fuel
pump**

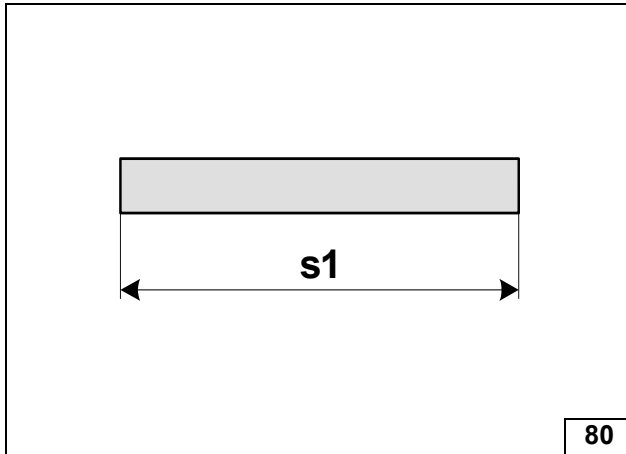
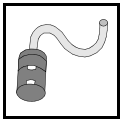

80

Combustion Air

s1 = 315

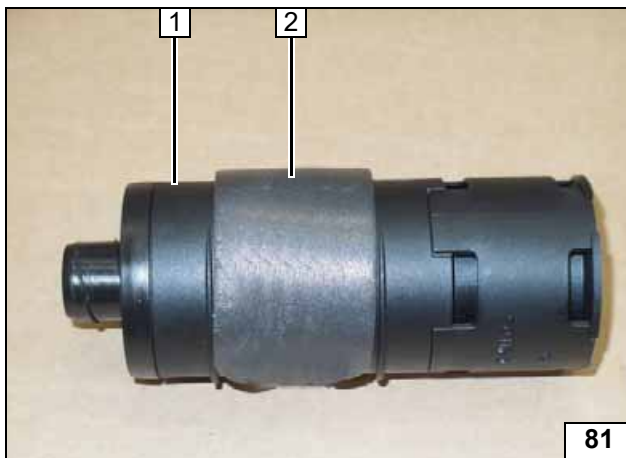

81

- 1 Silencer
- 2 Self-adhesive foam

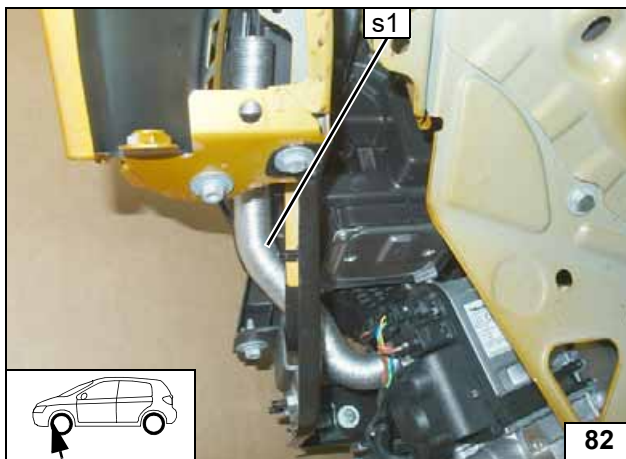

82

Cutting combustion air pipe to length

Preparing combustion air silencer



Installing combustion air pipe

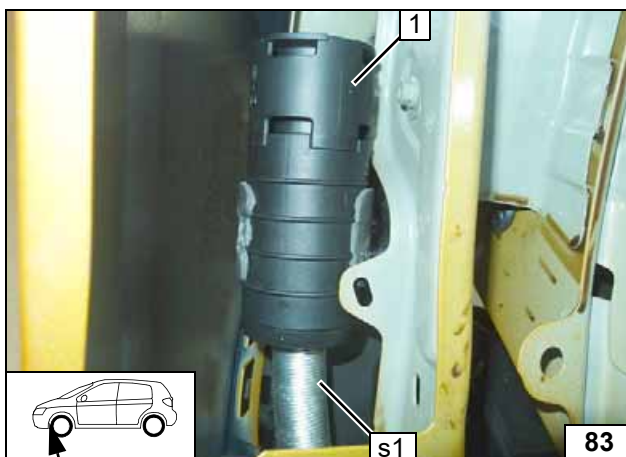

83

- 1 Silencer

Installing silencer

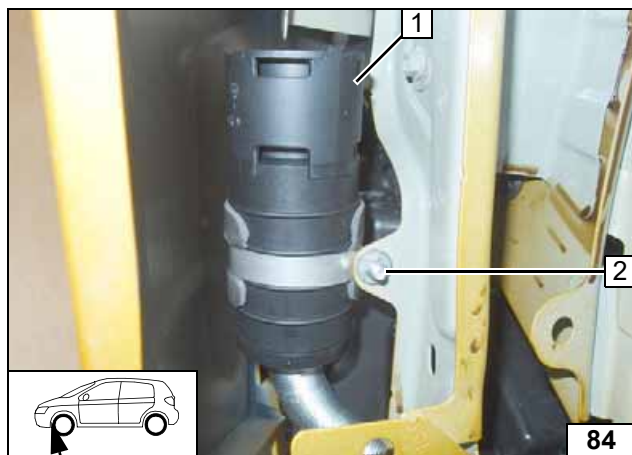
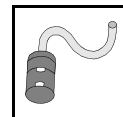

- 1 Silencer
- 2 M5x16 bolt, 51mm dia. clamp, original vehicle hole, large diameter washer, nut

Installing silencer

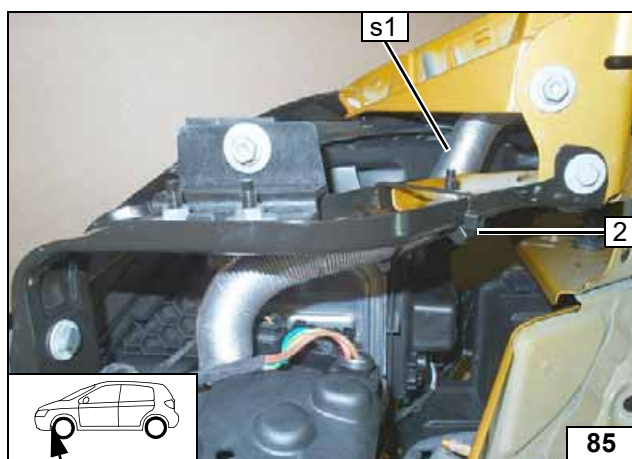

- 1 Cable tie

Fastening combustion air pipe

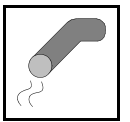

Exhaust Gas

a1 = 90
a2 = 170

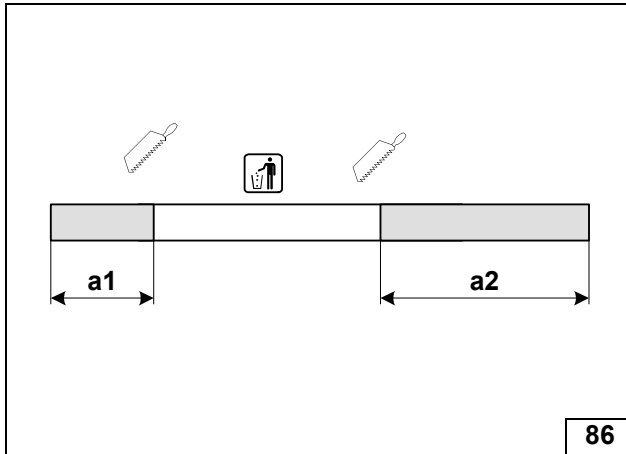

86

Preparing ex-
haust pipe

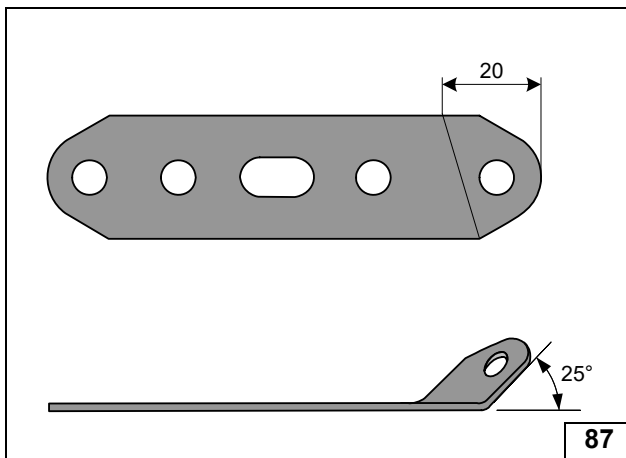

87

Preparing
perforated
bracket

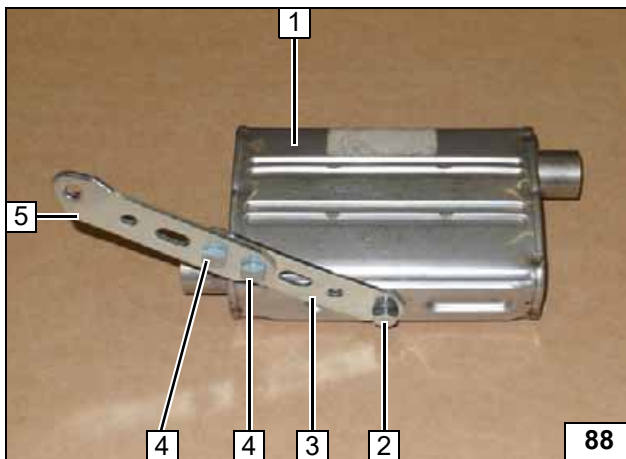

88

- 1 Silencer
- 2 Loosely mount M6x16 bolt, spring lockwasher
- 3 Perforated bracket
- 4 M6x12 bolt, flanged nut
- 5 Prepared perforated bracket

Premount-
ing silencer

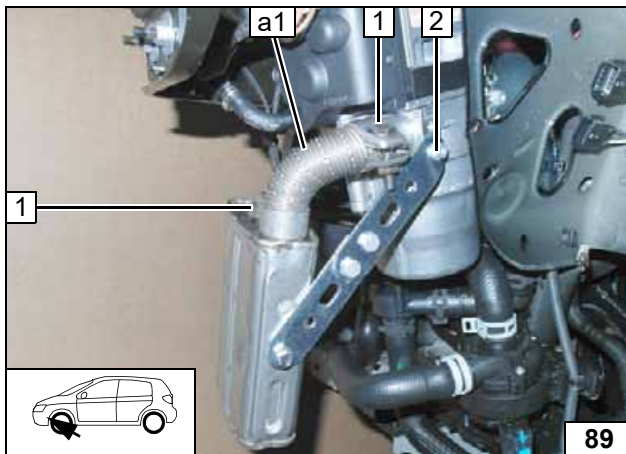

89

- 1 Hose clamp
- 2 5x13 self-tapping bolt

Installing
silencer

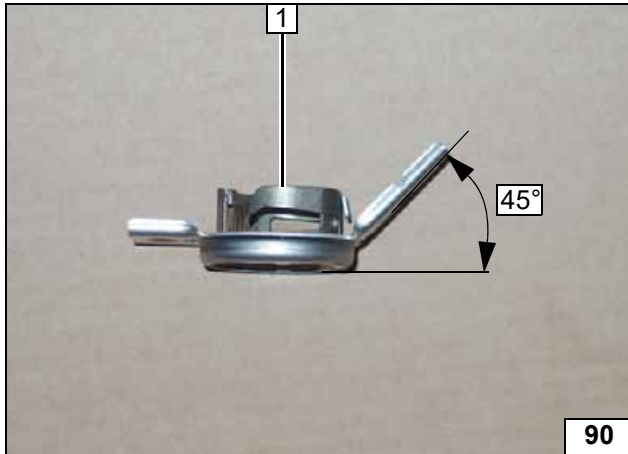
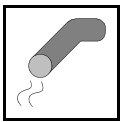

Exhaust End Fastener Installation

- 1 Exhaust end fastener

Bending exhaust end fastener

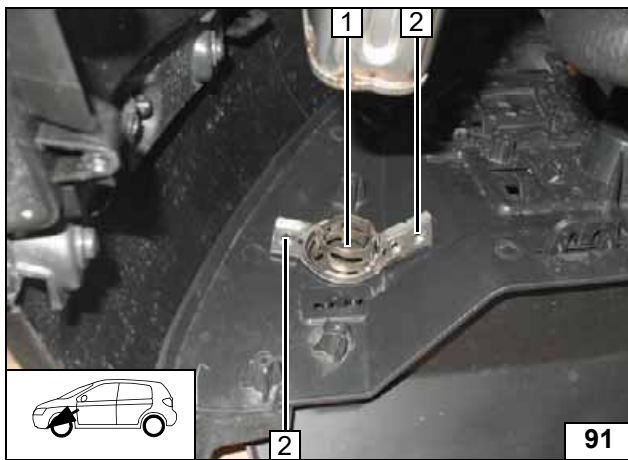

Work steps E1 and E3.

- 1 Hole
- 2 Hole pattern



Hole in lower bumper trim

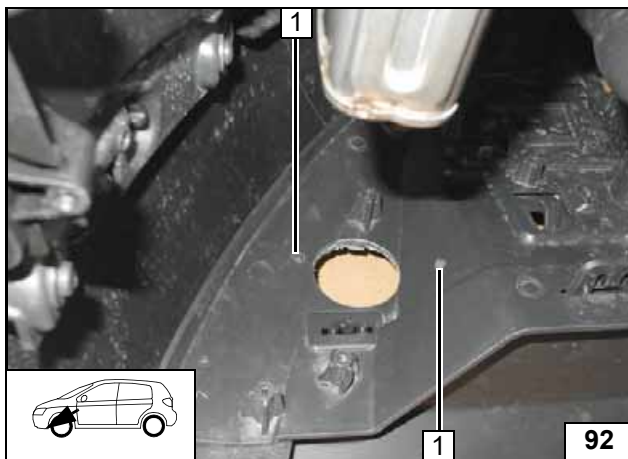

Work step E4.

- 1 Hole

Hole in lower bumper trim

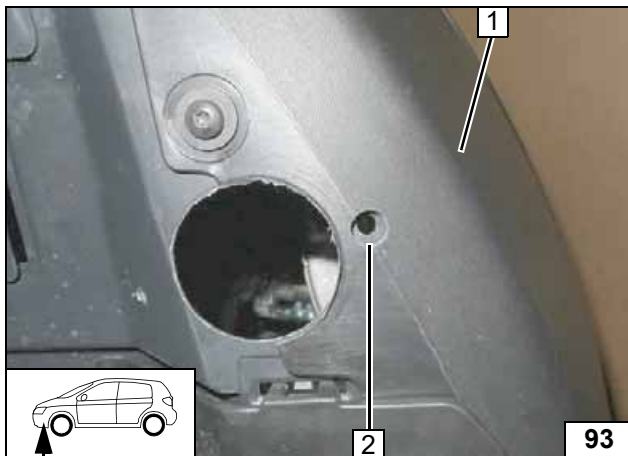

Drill 12mm dia. hole 2 for bolt head only in outer bumper trim 1.



Hole in bumper trim

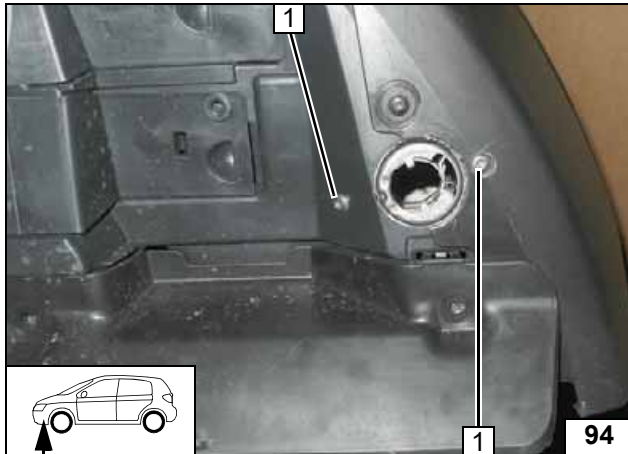
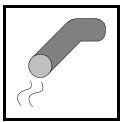

Work step E5.

- 1 5x13 self-tapping screw [2x]

Installing exhaust end fastener

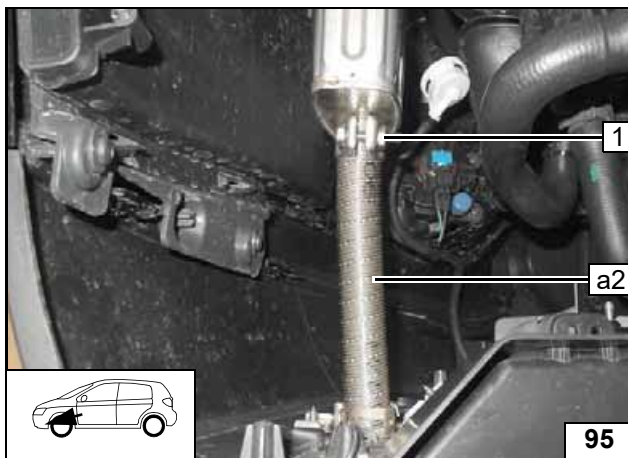

Ensure sufficient distance from neighbouring components, correct if necessary.



- 1 Hose clamp

Installing exhaust pipe a2

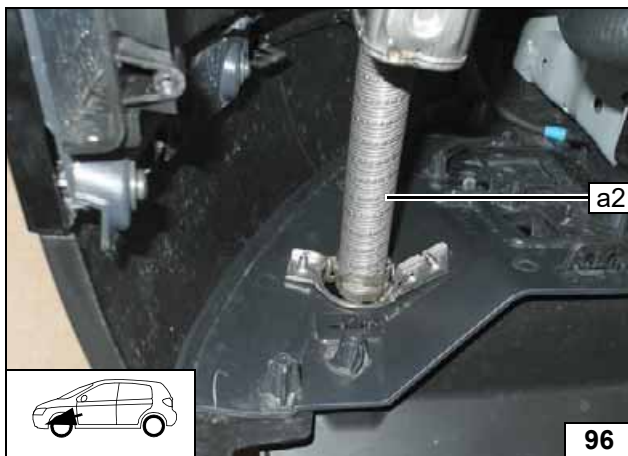

Work steps E6 - E8.



Installing exhaust pipe a2

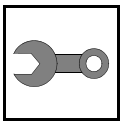

Final Work



Reassemble the components in reverse order. Check all hoses, clamps and all electrical connections for firm seating. Insulate loose wire ends and tie back.
Only use manufacturer-approved coolant. Spray the heater components with anti-corrosion wax (Tectyl 100K).

- **Connect the battery.**
- **Fill and bleed the coolant circuit according to the vehicle manufacturer's instructions.**
- **Program MultiControl CAR, teach Teleshield transmitter.**
- **For initial start-up and function check, please see installation instructions.**
- **If the fan function or A/C control panel settings need to be checked, see the installation documentation in the additional 'Webasto Standard' or 'Webasto Comfort' A/C control kit, section 'Final Work'.**
- **Place the 'Switch off parking heater before refuelling' caution label near the filler neck.**

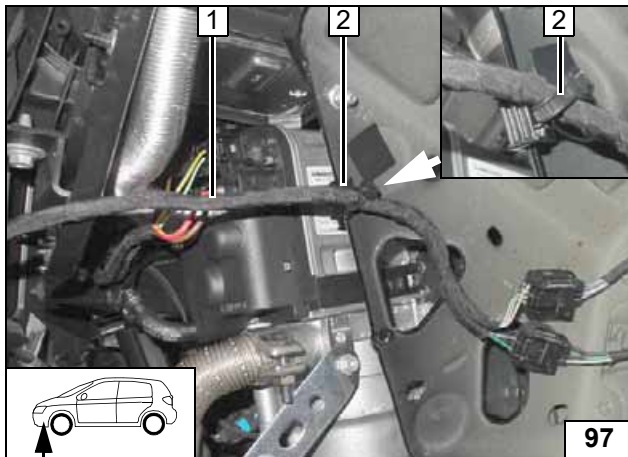

- 1 Original vehicle wiring harness
- 2 Edge clip cable tie

Attaching original vehicle wiring harness

Webasto Thermo & Comfort SE
Postfach 1410
82199 Gilching
Germany
Internet: www.webasto.com
Technical Extranet:
<http://dealers.webasto.com>



FuelFix Template

Top view

