

M Installation Documentation

Coldstart for water heater Thermo Top Evo

Hyundai Kona / Hyundai Tucson / Kia Sportage

Left-hand drive vehicle

Manufacturer	Model	Type	Model year	EG-BE-No. / ABE
Hyundai	Kona	YB	from 2018	e4* 2007/46* 1259*...

Motorisation	Fuel	Emission standard	Transmission type	Output [kW]	Displacement [cm ³]	Engine code
1.0P	Petrol	Euro 6	SG	88	998	G3LC
1.6P	Petrol	Euro 6	AG	130	1591	G4FJ

Manufacturer	Model	Type	Model year	EG-BE-No. / ABE
Hyundai	Tucson	TLE	from 2019	e11* 2007/46* 2724*...

Motorisation	Fuel	Emission standard	Transmission type	Output [kW]	Displacement [cm ³]	Engine code
1.6 T-GDI	Petrol	Euro 6d temp	SG	130	1591	G4FJ
1.6 T-GDI	Petrol	Euro 6d temp	AG	130	1591	G4FJ
1.6 GDI	Petrol	Euro 6d temp	SG	97	1591	G4FD

Manufacturer	Model	Type	Model year	EG-BE-No. / ABE
Kia	Sportage	QLE	from 2019	e11* 2007/46* 3144*...

Motorisation	Fuel	Emission standard	Transmission type	Output [kW]	Displacement [cm ³]	Engine code
1.6 T-GDI	Petrol	Euro 6d temp	SG	130	1591	G4FJ
1.6 T-GDI	Petrol	Euro 6d temp	AG	130	1591	G4FJ
1.6 GDI	Petrol	Euro 6d temp	SG	97	1591	G4FD

Total installation time	Note
1.5 hours	Applies only to the retroffing of a cold start system in vehicles with an already retrofitted parking heater

Contents

1	List of abbreviations	3
2	Installation notes	4
2.1	Information on Validity	4
2.2	Components used	4
2.3	Validity Notes	4
2.4	Information on total installation time	4
3	About this document	5
3.1	Purpose of the document	5
3.2	Warranty and liability	5
3.3	Safety	5
3.4	Using this document	6
4	Technical Information	7
5	Installation overview	8
6	Wiring diagram	10
7	Electrical system	12
7.1	Electrical system preparation	12
7.2	Connection in passenger compartment	14
7.2.1	Installing CLR module	14
7.2.2	Connecting connectors and sockets for MCC option	16
7.2.3	Connecting connectors and sockets for Teletstart option	17
7.2.4	Connection to OBD socket outlet	18
7.3	Connection in engine compartment of Hyundai Kona	19
7.4	Connection in engine compartment of Hyundai Tucson / Kia Sportage	20
7.5	Connection to engine control unit for all vehicles	21
8	Final work	22

1 List of abbreviations

AG	Automatic transmission
CLR	Cold start module
RTD	Temperature sensor
SG	Manual transmission

2 Installation notes

2.1 Information on Validity

This installation documentation applies to vehicles listed on page 1, assuming technical modifications to the vehicle do not affect installation, any liability claims excluded.



Vehicle and engine types, equipment variants and other specifications not listed in this installation documentation have not been tested. The installation is not permitted.

2.2 Components used

Designation	Order number
Additional cold start kit for Hyundai / Kia petrol	1325691B
Cold start installation documentation for Hyundai Kona Tucson Kia Sportage 2018 petrol	1326425C

2.3 Validity Notes

This installation documentation applies only in combination with:

Designation	Order number
Installation kit for Hyundai Kona 2017 1.0 petrol	1326390_
Installation documentation for Hyundai Kona 2017 1.0 petrol	1326391_

or

Designation	Order number
Installation kit for Hyundai Kona 2017 1.6 petrol 4WD	1326393_
Installation documentation for Hyundai Kona 2017 1.6 petrol 4WD	1326394_

or

Designation	Order number
Installation kit for Hyundai Kona 2018 1.6 petrol 2WD	1327298_
Installation documentation for Hyundai Kona 2018 1.6 petrol 2WD	1327299_

or

Designation	Order number
Set (including installation kit and cold start kit) for Hyundai Tucson Kia Sportage 2019 petrol Inline	1327061_
Installation documentation for Hyundai Tucson Kia Sportage 2019 petrol Inline	1327060_

2.4 Information on total installation time

The total installation time includes the time needed for mounting and demounting the vehicle-specific components, the cold start-specific installation times and all other times required for the subsequent installation of the cold start kit with a parking heater that has already been retrofit.

The total installation time may vary for vehicle equipment other than provided.

3 About this document

3.1 Purpose of the document

This installation documentation is part of the product and contains all the information required to ensure professional vehicle specific installation of the:

Cold start kit

3.2 Warranty and liability

Webasto shall assume no liability for defects, damage and injuries resulting from a failure to observe the installation, repair and operating instructions of the information contained in them.

This liability exclusion particularly applies to improper installations and repairs by untrained persons or in the case of a failure to use genuine spare parts.

The liability due to culpable disregard to life, limb or health and due to damage or injuries caused by a wilful or reckless breach of duty remain unaffected, as does the obligatory product liability.

Installation should be carried out according to the general, standard rules of technology. Unless specified otherwise, fasten hoses, lines and wiring harnesses to original vehicle lines and wiring harnesses using cable ties. Insulate loose wire ends and tie back. Connectors on electronic components must audibly snap into place during assembly.

Spray unfinished body areas, e.g. drilled holes, with anti-corrosion wax (Tectyl 100K).

Observe the instructions and guidelines of the respective vehicle manufacturer for demounting and mounting vehicle specific components.

The initial start-up is to be executed with the Webasto Thermo Test Diagnosis.

When installing a programmable control module (e.g. a PWM Gateway), the corresponding settings must be checked or adjusted.

3.2.1 Statutory regulations governing installation

The Thermo Top Evo heater has been type-tested and approved in accordance with ECE-R 10 (EMC) and ECE-R 122 (heater). The regulations of these guidelines are binding in the scope of the Directive 70/156/EEC and/or 2007/46/EC (for new vehicle models from 29/04/2009) and should also be observed in countries in which there are no special regulations.

The heater is licensed in accordance with paragraph 19, section 3, No. 2b of the StVZO (German Road Traffic Licensing Authority).

3.3 Safety

Qualifications of installation personnel

The installation personnel must have the following qualifications:

- Successful completion of Webasto training
- Corresponding qualification for working on technical systems

Regulations and legal requirements

The regulations from the heater's general installation and operating instructions must be observed.

3.3.1 Safety information on installation

Danger posed by live parts

- ▶ Prior to installation, disconnect the vehicle from the voltage supply.
- ▶ Make sure the electrical system is earthed correctly.
- ▶ Always comply with legal requirements.
- ▶ Observe data on type label.

Danger of fire and leaking toxic gases due to improper installation

- ▶ Vehicle parts in the vicinity of the heater must be protected against excessive heating by the following measures:
 - ⇒ Maintain minimum safety distances.
 - ⇒ Ensure adequate ventilation.
 - ⇒ Use fire-resistant materials or heat shields.

Danger due to sharp edges

- Lacerations
- Short circuit due to electrical wire damage
- ▶ Fit protectors on sharp edges.

3.4 Using this document

Before installing and operating the heater, read this installation documentation, the installation instructions of the heater, the operating instructions and supplementary sheets provided.

3.4.1 Explanatory Notes on the Document

There is an identification mark near the respective work step to allow you to quickly allocate the other applicable documents to the Webasto components to be installed:

Generally valid Webasto documentation	
Vehicle-specific installation documentation	
Vehicle-specific installation documentation of the cold start kit	
Webasto Comfort A/C control	
Webasto Standard A/C control	
Tank extracting device (e.g. FuelFix)	
Exhaust end fastener (EFIX)	
Combustion air intake silencer	
Spacer bracket (ASH)	

3.4.2 Use of symbols



DANGER

Type and source of the risk

Consequences: Failure to follow the instructions can result in death

► Actions to protect yourself against risks.



WARNING

Type and source of the risk

Consequences: Failure to follow the instructions can lead to serious or even fatal injuries

► Actions to protect yourself against risks.



CAUTION

Type and source of the risk

Consequences: Failure to follow the instructions can lead to minor injuries

► Actions to protect yourself against risks.



Type and source of the risk

Consequences: Failure to follow the instructions can lead to material damage

► Actions to protect yourself against risks.



Reference to the vehicle manufacturer's specific documents.



Note on a special technical feature

3.4.3 Work step identification marks

The ongoing work step is indicated on the outside top corner of the page:

Mechanical system	Electrical system	High-voltage	Coolant
Combustion air	Fuel	Exhaust	Software

3.4.4 Orientation aid

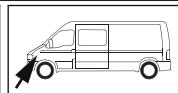
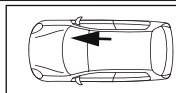

The arrow indicates the position on the vehicle and the viewing angle

3.4.5 Use of highlighting

Highlight	Explanation
►	Necessary action
⇒	Result of an action
1 / 12 / a1	Position numbers for the image descriptions
① / ⑫ / Ⓐ	Position numbers for the image descriptions for electrical wires and coolant hose sections

4 Technical Information

Dimension specifications

- All dimensions specified in mm
- Perforated brackets and mounting angles are shown to scale
- Observe data regarding scale on the templates

Tightening torque specifications

- Tighten all screw connections in accordance with manufacturer's instructions or in accordance with state-of-the-art-technology

Necessary special tools

- Automatic wire stripper 0.2 - 6 mm²
- Crimping pliers for cable lugs 0.5 – 10 mm²
- Crimping pliers for male connector 0.14 – 6 mm²
- Crimping pliers for connector 0.25 – 6 mm²
- Torque wrench for 2.0 - 10 Nm
- Deep-hole marker

5 Installation overview

1.0 petrol Kona

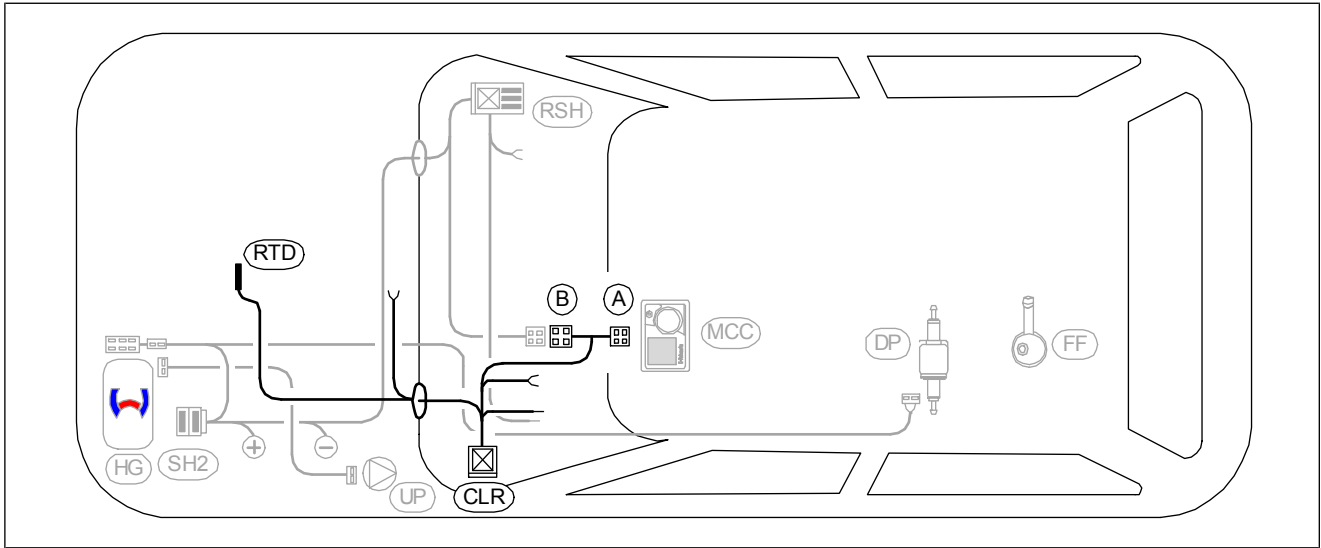

Fig. 1

1.6 petrol Kona 4WD

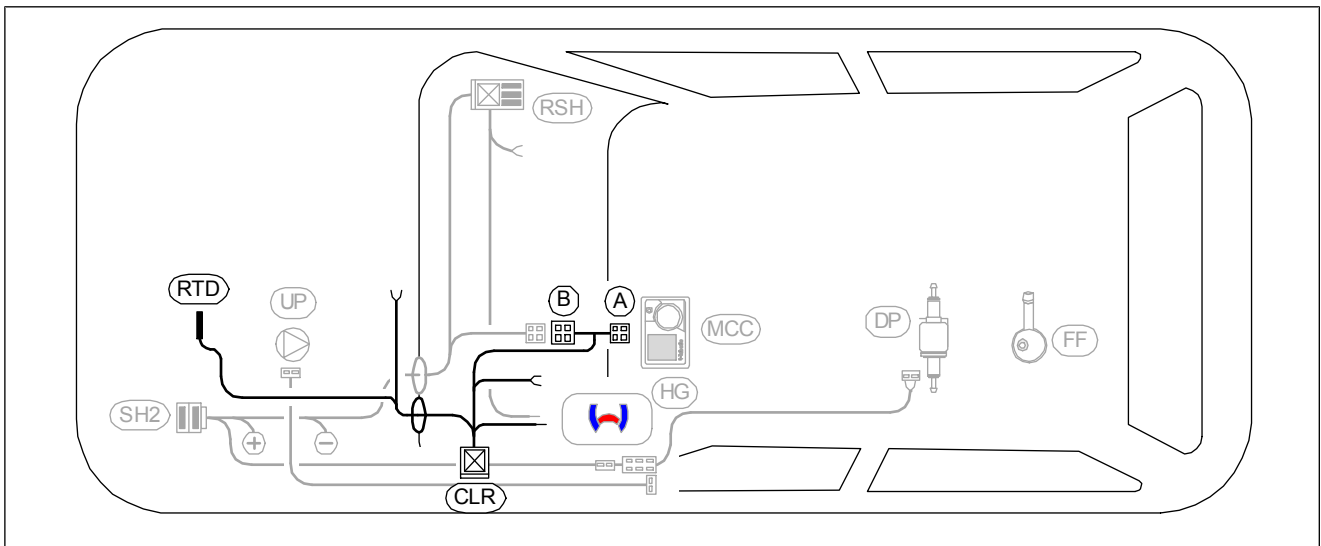

Fig. 2

1.6 petrol Kona 2WD

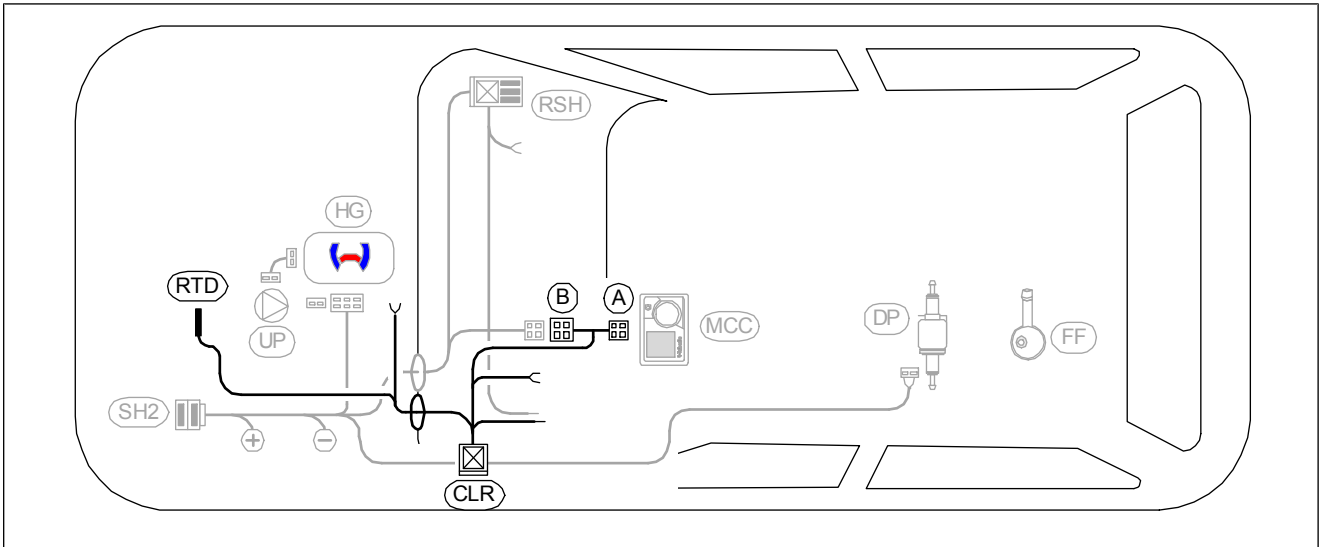

Fig. 3

Tucson / Sportage

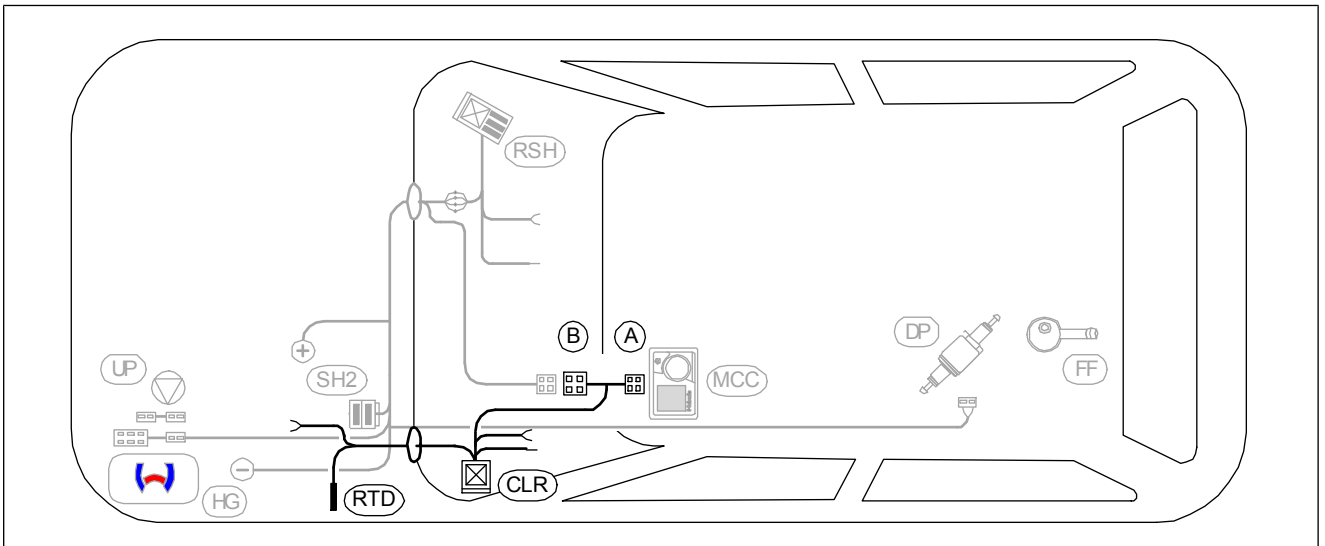

Fig. 4

Legend to installation overview

Abbreviation	Component
CLR	CLR module
RTD	Temperature sensor
A/B	Adapter connector



6 Wiring diagram

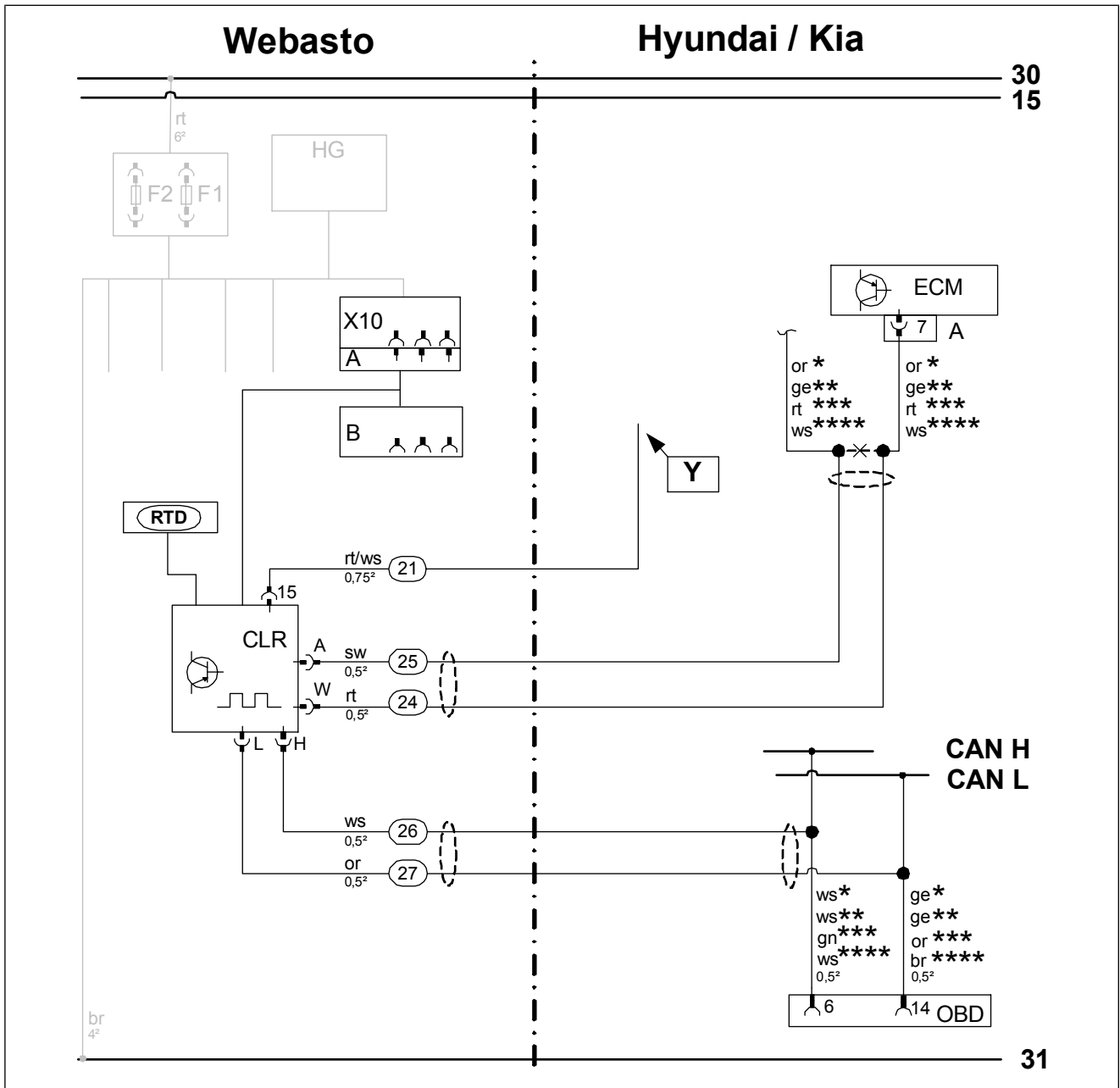

Fig. 5



Legend to wiring diagram



The vehicle connector and component designations are freely chosen by Webasto.
Cable colours may vary.

Vehicle components		Symbols	
Abbreviation	Component	Abbreviation	Designation
ECM	Engine control unit	X	Cutting point
A	60-pin ECM connector	*	1.6P Kona
OBD	ON-Board Diagnosis	**	1.0P Kona
		***	Tucson
		****	Sportage
		Y	The connection takes place together with the connection of the fan controller and according to the heater installation documentation

Webasto components		Cable colours	
Abbreviation	Component	Abbreviation	Colour
A	Male plug for CLR module wiring harness	bg	beige
B	Female plug for CLR module wiring harness	bl	blue
C	Male plug for adapter wiring harness	br	brown
D	Female plug for adapter wiring harness	dbl	dark blue
E	Male plug for Plug&Play wiring harness	dgn	dark green
F	Female plug for Plug&Play wiring harness	ge	yellow
CCL GW	CAN CAN LIN Gateway	gn	green
CL GW	CAN LIN Gateway	gr	grey
CLR	Cold start module	hbl	light blue
D1	Diode	hgn	light green
D2	Diode group	la	salmon
F0	Additional fuse for power supply	or	orange
F1	Heater main fuse	pk	pink
F2	Passenger compartment fan controller main fuse	rt	red
F3	Control element fuse	sw	black
F4	Fan controller fuse	vi	violet
F5	Additional fuse	ws	white
HG	Heater TT-Evo		
K1	Relay K1		
K2	Relay K2		
K3	Relay K3		
LIN GW	LIN Gateway		
PWM GW	Pulse width modulator gateway		
RSH	Relay and fuse holder of passenger compartment		
RTD	Temperature sensor		
X10	Female plug for control element		
Y	Power adapter		



7 Electrical system

7.1 Electrical system preparation

Assigning / preparing wires

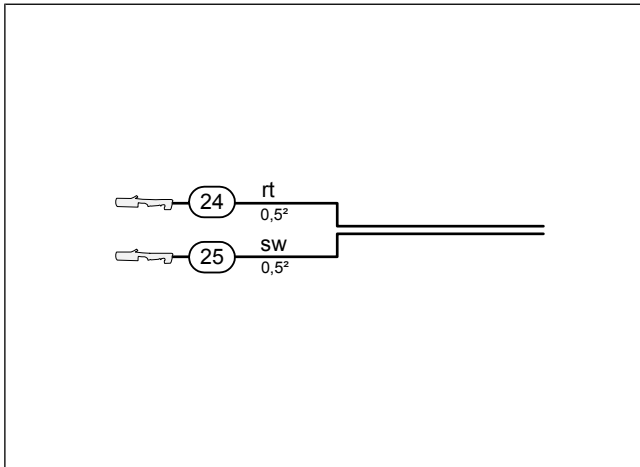

Fig. 6

- ②4 Red (rt) wire of cold start wiring harness
- ②5 Black (sw) wire of cold start wiring harness



Preparing CLR module

Produce all following electrical connections as shown in the system wiring diagram.

- ▶ Detach black (sw) wire from terminal A and insulate.
- ▶ Connect red (rt) wire (24) and black (sw) wire (25).

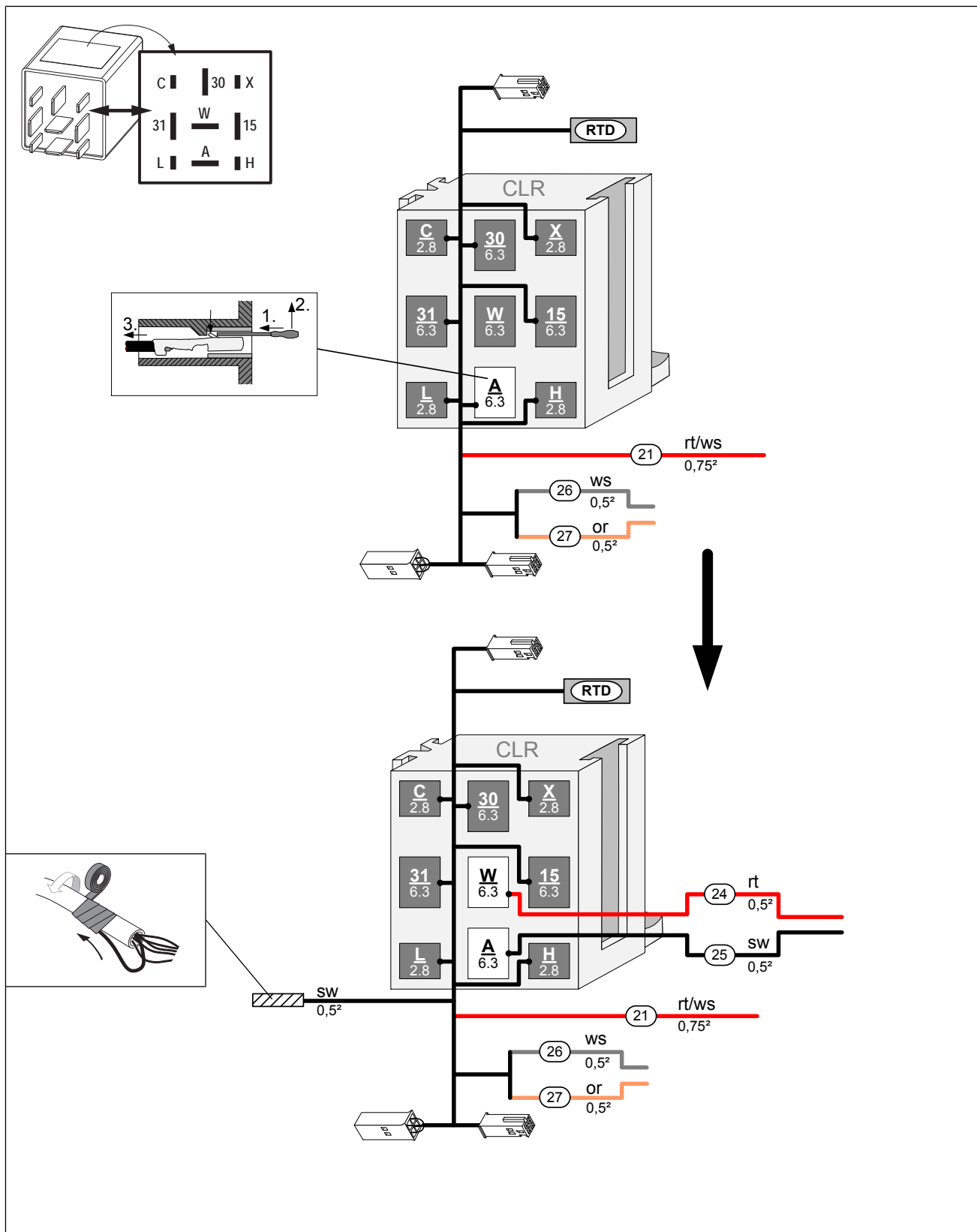

Fig. 7



Mounting perforated bracket

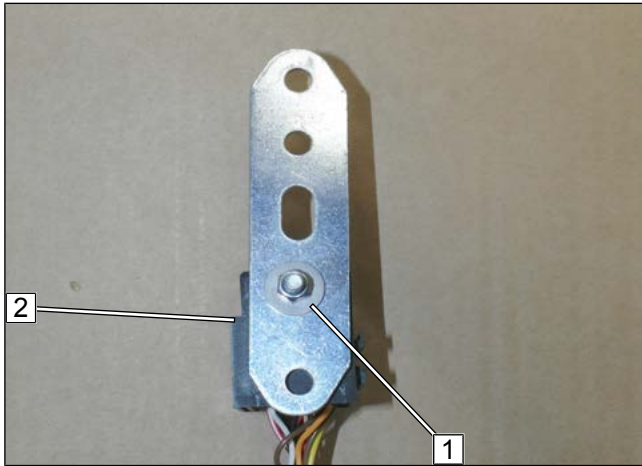

Fig. 8

- 1 M5x16 bolt, large diameter washer, CLR module socket, perforated bracket, large diameter washer, nut
- 2 CLR module socket

Installing CLR module

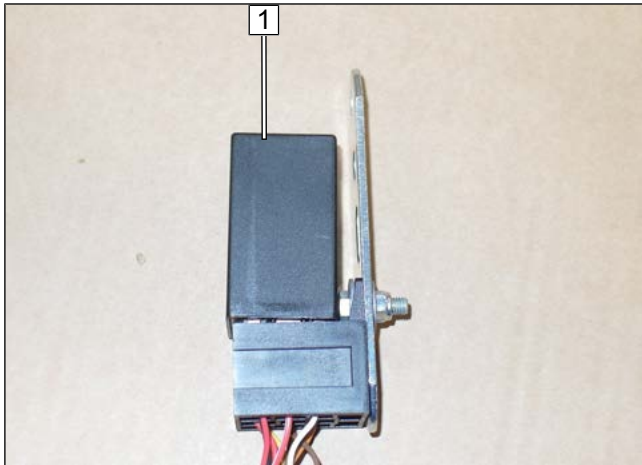

Fig. 9

- 1 CLR module

7.2 Connection in passenger compartment

7.2.1 Installing CLR module

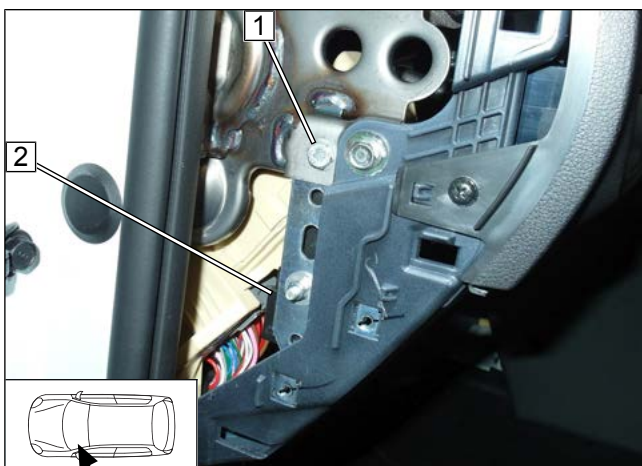

Fig. 10

Hyundai Kona view

- 1 M6x20 bolt, original vehicle hole, perforated bracket, flanged nut
- 2 CLR module, premounted

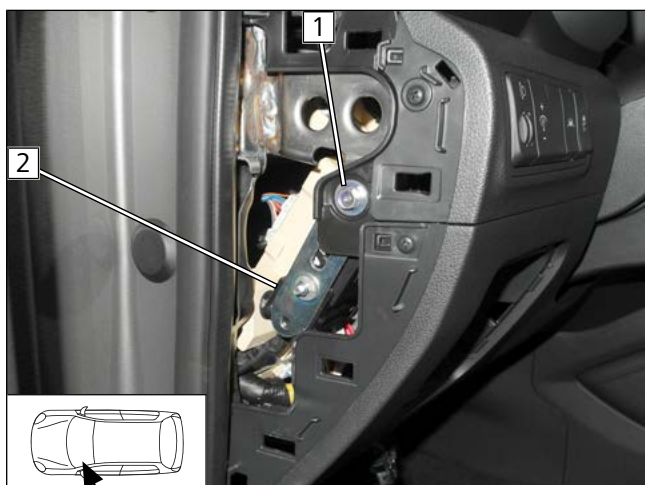

Fig. 11



Hyundai Tucson view

- 1 Original vehicle bolt
- 2 CLR module, premounted

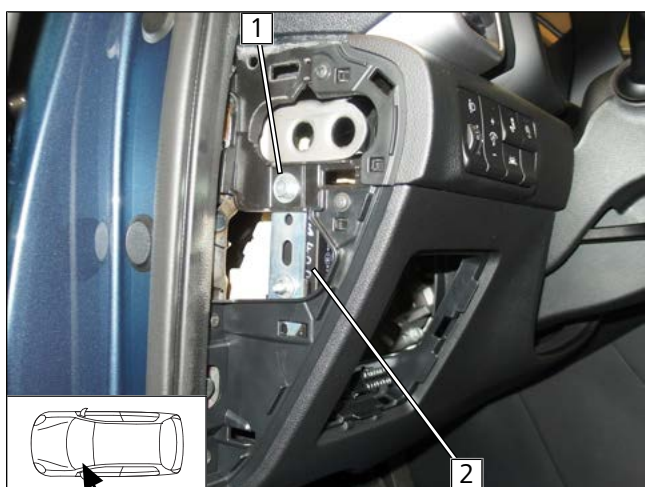

Fig. 12



Kia Sportage view

- 1 Original vehicle bolt
- 2 CLR module, premounted



7.2.2 Connecting connectors and sockets for MCC option

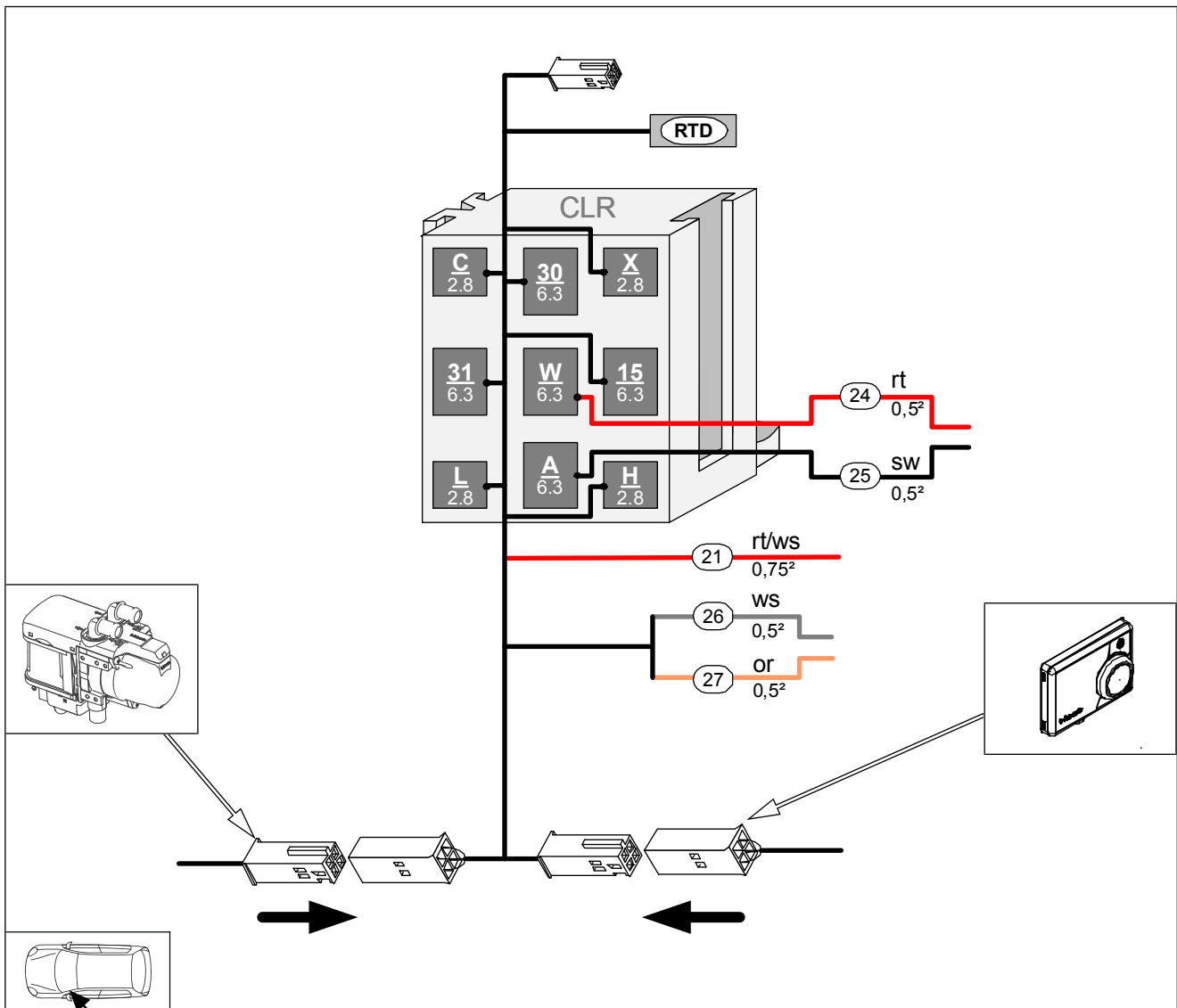

Fig. 13



7.2.3 Connecting connectors and sockets for Telearstart option

Mounting yellow wire in connector and socket of the Telearstart wiring harness

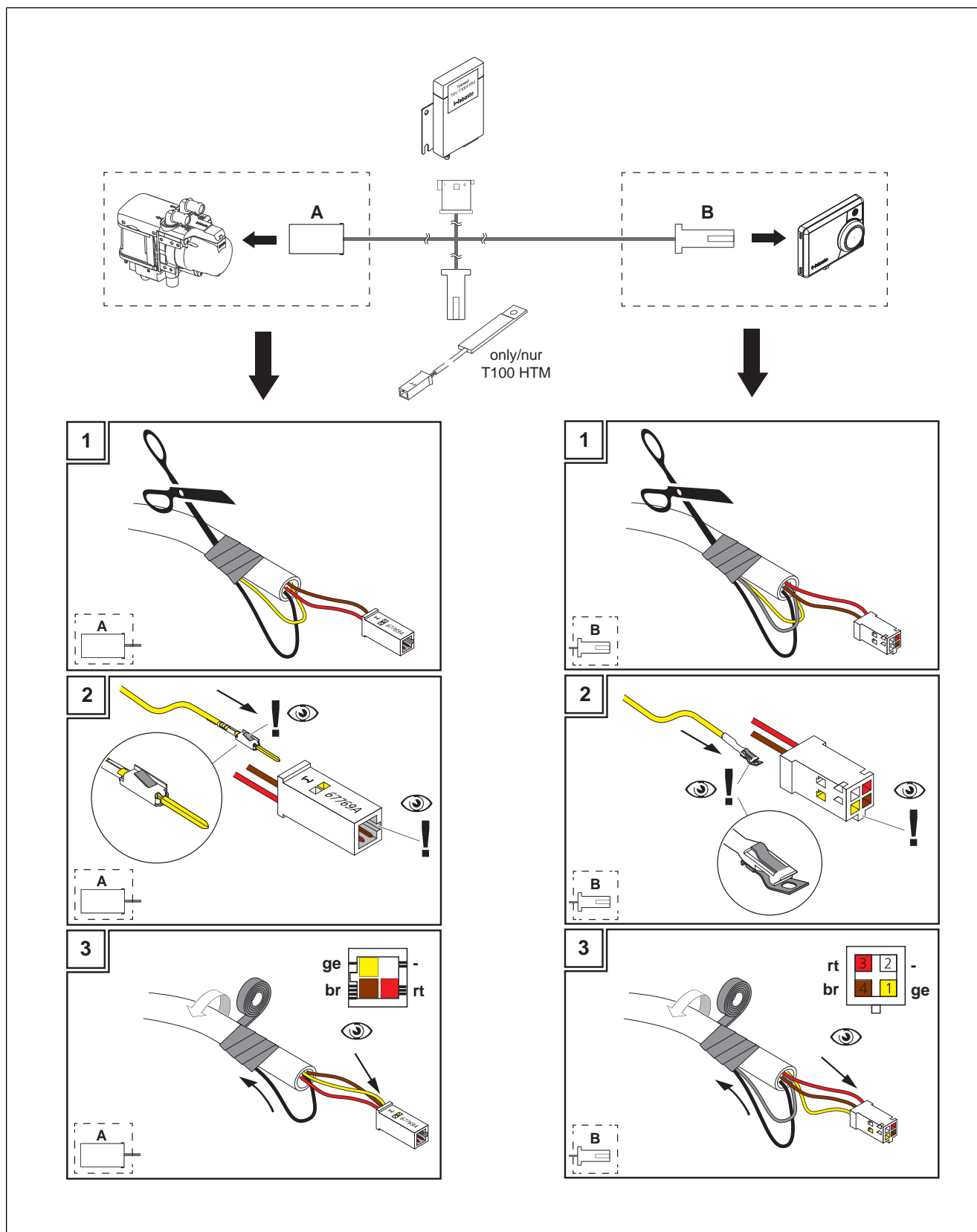

Fig. 14



Connecting connectors and sockets

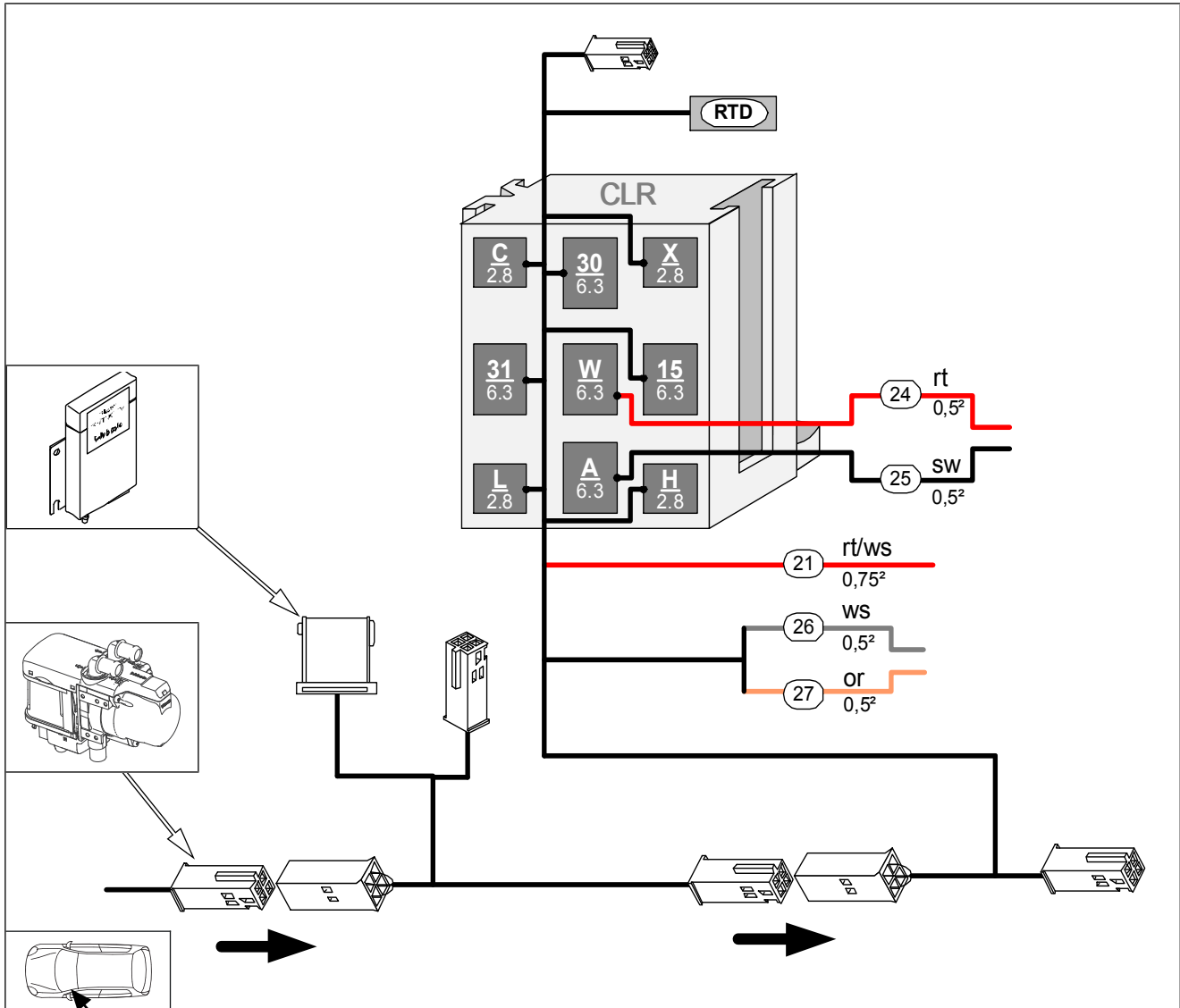

Fig. 15

7.2.4 Connection to OBD socket outlet

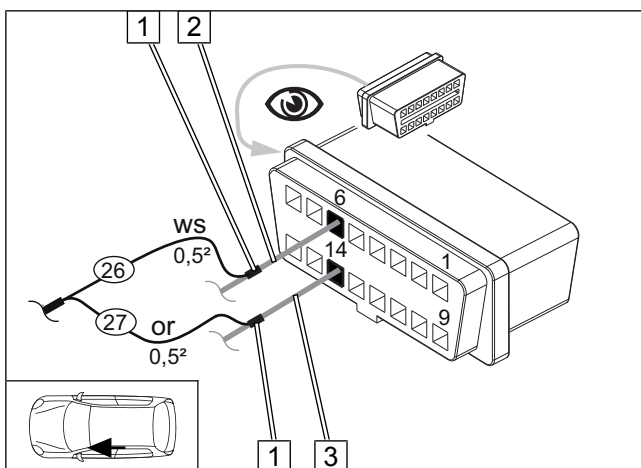

Fig. 16



Further information can be found in the vehicle manufacturer's technical documentation.

► Remove OBD socket outlet from bracket.



► Crimp and shrink butt connector **1**

- 2** Wire (cable colour according to system wiring diagram) OBD socket outlet/pin 6
- 3** Wire (cable colour according to system wiring diagram) OBD socket outlet/pin 14
- 26** White (ws) wire of CLR module/ H cold start wiring harness
- 27** Orange (or) wire of CLR module/ L cold start wiring harness



7.3 Connection in engine compartment of Hyundai Kona

Installing lines

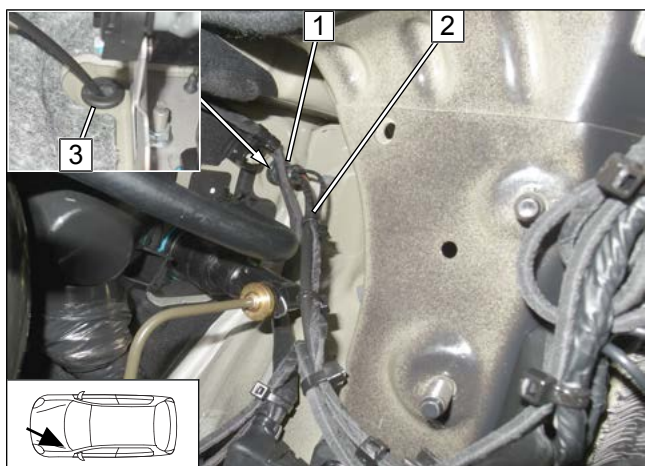

Fig. 17

► Route wires (24) and (25) as well as temperature sensor (RTD) 2 in the engine compartment.

- 1 Protective rubber plug on engine side
- 3 Protective rubber plug on passenger compartment side

Routing and fastening temperature sensor (RTD) in engine compartment

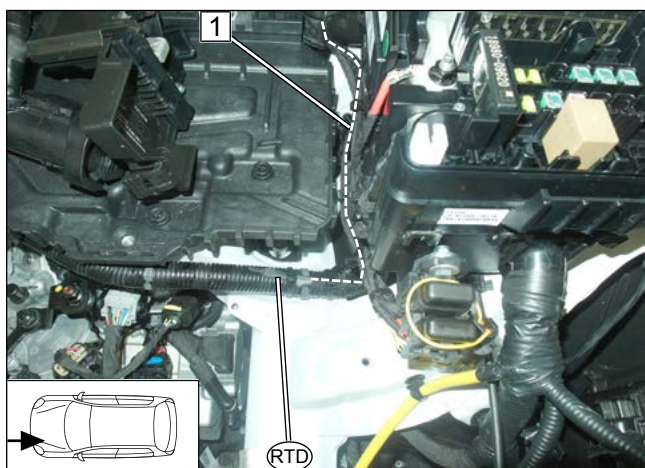

Fig. 18

► Fasten (RTD) using cable ties as shown.

- 1 Wiring harness of RTD

Detaching engine control unit connector

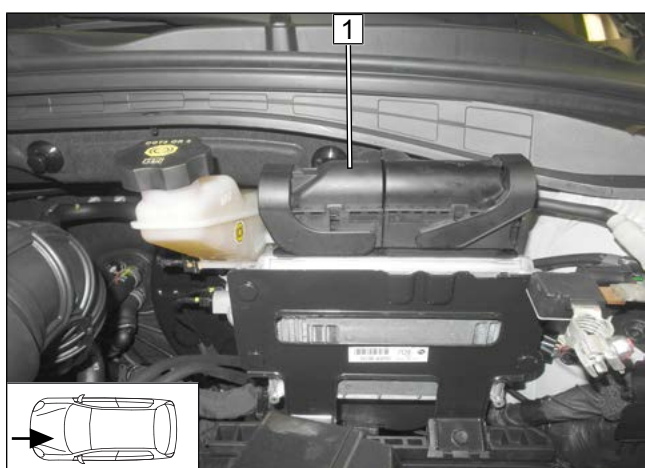

Fig. 19

- 1 60-pin connector A



7.4 Connection in engine compartment of Hyundai Tucson / Kia Sportage

Installing lines

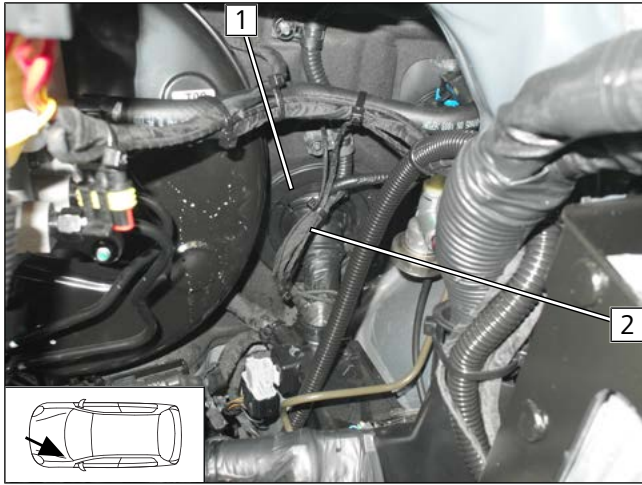

Fig. 20

- ▶ Route wires **24** and **25** as well as temperature sensor **RTD2** in the engine compartment and fasten using cable ties.

1 Protective rubber plug

Routing and fastening temperature sensor **RTD** in engine compartment

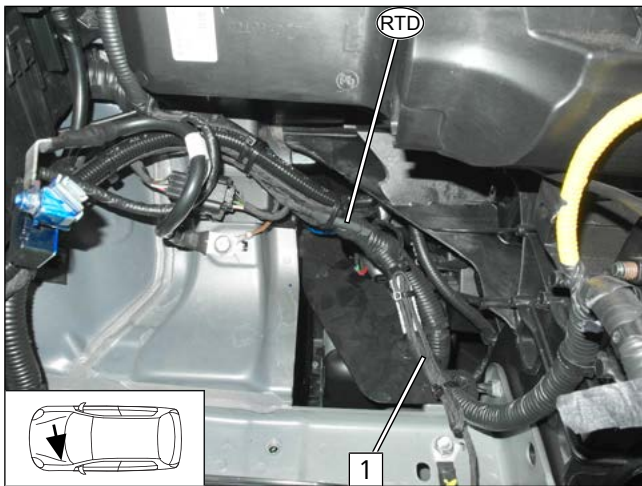

Fig. 21

- ▶ Fasten **RTD** using cable ties as shown.

1 Wiring harness of RTD

Detaching engine control unit connector

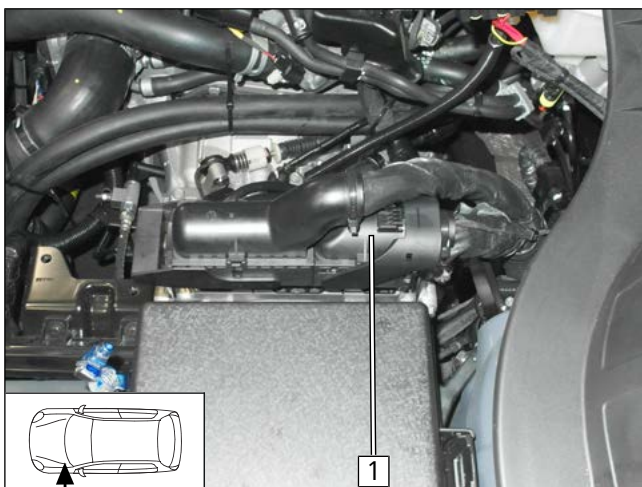

Fig. 22

1 60-pin connector A



7.5 Connection to engine control unit for all vehicles

View of engine control unit connector A

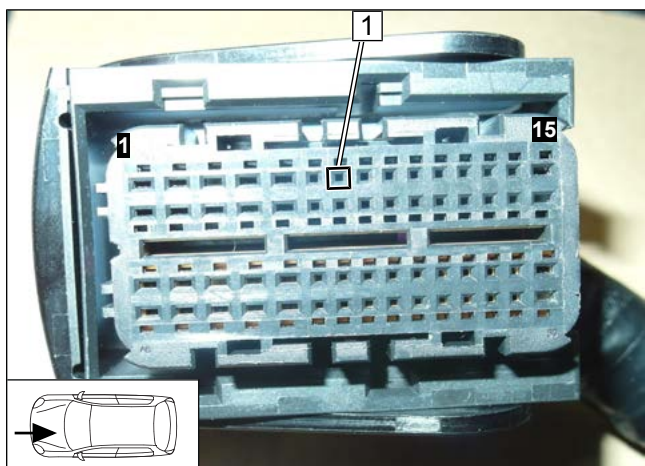

Fig. 23

This and next figures show a Hyundai Kona

- 1 Connector A of engine control unit, pin 7, on contact side

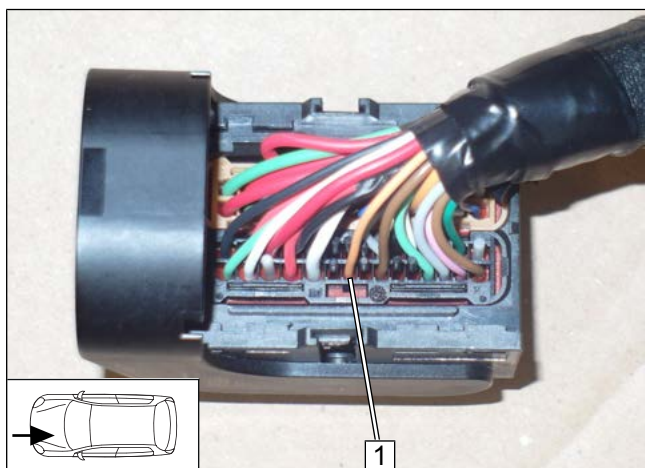

Fig. 24



► Remove the upper cover from connector A and detach part of the wiring harness wrapping. Insulate and reinstall after completion.

- 1 Wire (cable colour according to system wiring diagram) of connector A, engine control unit, pin 7, on wiring side

Connection to engine control unit

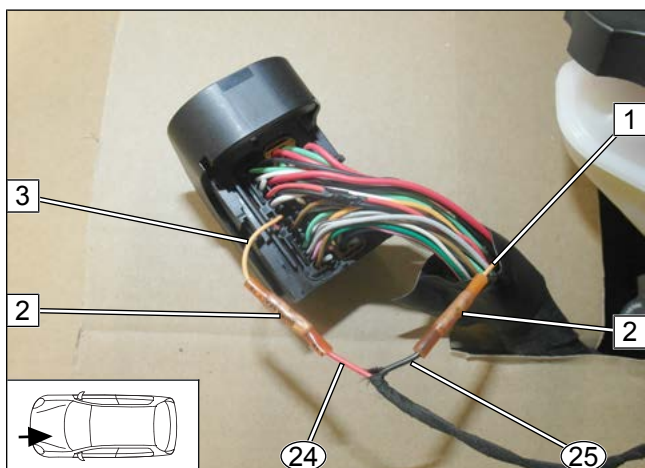

Fig. 25



► Crimp and shrink butt connector **2**

- 1 Wire (cable colour according to system wiring diagram)
- 3 Wire (cable colour according to system wiring diagram) of connector A, engine control unit, pin 7
- 24 Red (rt) wire of CLR module/W from cold start wiring harness
- 25 Black (sw) wire of CLR module/A from cold start wiring harness



8 Final work



- ▶ Final work is not carried out until the installation of the heater in the vehicle has been completed
- ▶ Check all electrical connections for firm seating
- ▶ Insulate and tie back loose lines



These are the original instructions. The German language is binding.
You can request your language if it is missing. The telephone number of each country can be found in the Webasto service centre leaflet or the website of the respective Webasto representative of your country.

Ident No. 1326425C_EN • 09/19 • Errors and omissions excepted • © Webasto Thermo & Comfort SE • 2019

Webasto Thermo & Comfort SE
Postfach 1410
82199 Gilching
Germany

Company address:
Friedrichshafener Str. 9
82205 Gilching
Germany

Technical Extranet: <https://dealers.webasto.com>



WWW.WEBASTO.COM