

K Installation documentation

Thermo Top Evo for water heater

BMW 5 Series

Left-hand drive vehicle

Manufacturer	Model	Type	Model year	EG-BE-No. / ABE		
BMW	5 Series	G30 / G31	from 2017	e1* 2007/46* 1688*...		
Motorisation	Fuel	Emission standard	Transmission type	Out-put[kW]	Displace-ment[cm ³]	Engine code
2.0D	Diesel	Euro 6	ASG	140	1995	B47D20
3.0D	Diesel	Euro 6	ASG	195	2993	B47D30

Validity	Equipment variants	Model
		BMW 5 Series
Verified equipment variants	2 zone automatic air-conditioning	X
	LED main headlights	X
	LED front fog lights	X
	Alarm system	X
	dynamic cornering light	X
	4 WD	X
Unverified equipment variants	3 zone automatic air-conditioning	X

Total installation time	Note
9.0 hours	

Contents

1	List of abbreviations	3	13	Electrical system of control elements	41
2	Installation notes	4	13.1	MCC option	41
2.1	Information on Validity	4	13.2	Telestart option	41
2.2	Components used	4	13.3	ThermoCall option	42
2.3	Information on Total Installation Time	4	14	Final Work	44
2.4	Installation recommendations	4	15	FuelFix template	47
3	About this document	5			
3.1	Purpose of the document	5			
3.2	Warranty and liability	5			
3.3	Safety	5			
3.4	Using this document	6			
4	Technical Information	7			
5	Preparing measures	8			
5.1	Vehicle preparation	8			
5.2	Heater preparation	8			
6	Installation overview	9			
7	Mechanical system	10			
7.1	Preparing installation location	10			
7.2	Premounting heater	12			
7.3	Heater installation part 1	18			
7.4	Hose routing diagram	19			
7.5	Heater installation part 2	20			
8	Electrical system of engine compartment	22			
9	Fuel	28			
9.1	Routing fuel line	28			
9.2	Installing FuelFix	31			
9.3	Fuel pump connection	35			
10	Exhaust	37			
11	Final work in engine compartment	39			
12	Electrical system of passenger compartment	40			
12.1	Mounting cold start system	40			
12.2	Air-conditioning control	40			

1 List of abbreviations

4 WD	All-wheel
AAC	Automatic air-conditioning
ASG	Semi-automatic transmission
ASH	Spacer bracket
DP	Fuel pump
EFIX	Exhaust end fastener
FF	FuelFix (tank extracting device)
Fig.	Figure
HG	Heater
MCC	MultiControl (control element)
SH2	Engine compartment fuse holder for F1/F2
UP	Coolant pump

2 Installation notes

2.1 Information on Validity

This installation documentation applies to vehicles listed on page 1, assuming technical modifications to the vehicle do not affect installation, any liability claims excluded. Depending on the vehicle version and equipment, modifications may be necessary during installation with respect to this installation documentation. Vehicle and engine types, equipment variants and other specifications not listed in this installation documentation have not been tested.

2.2 Components used

Designation	Order number
Basic delivery scope of Thermo Top Evo	In accordance with price list
Installation kit (including cold start kit) BMW 5 Series diesel	1326676A
Additional 'Webasto Comfort' A/C control kit for BMW X3 / 5 Series	1326680A
In case of Telestart, control element, as well as indicator lamp in consultation with end customer	In accordance with price list
In case of MultiControl CAR installation - installation frame for MultiControl	9030077_

2.3 Information on Total Installation Time

The total installation time includes the time needed for mounting and demounting the vehicle-specific components, the heater specific installation time and all other times required for the system integration and initial start-up of the heater.

The total installation time may vary for vehicle equipment other than provided.

2.4 Installation recommendations

Arrange for the vehicle to be delivered with the tank only about $\frac{1}{4}$ full.

For the MultiControl CAR option, the recommended installation locations for the Telestart or ThermoCall push button should be confirmed with the end customer.

Depending on the space required and the vehicle manufacturer's instructions, we recommend the use of a vehicle battery with a higher electrical capacity.

3 About this document

3.1 Purpose of the document

This installation documentation is part of the product and contains all the information required to ensure professional vehicle specific installation of the:

Thermo Top Evo heater

3.2 Warranty and liability

Webasto shall assume no liability for defects, damage and injuries resulting from a failure to observe the installation, repair and operating instructions of the information contained in them.

This liability exclusion particularly applies to improper installations and repairs by untrained persons or in the case of a failure to use genuine spare parts.

The liability due to culpable disregard to life, limb or health and due to damage or injuries caused by a wilful or reckless breach of duty remain unaffected, as does the obligatory product liability.

Installation should be carried out according to the general, standard rules of technology. Unless specified otherwise, fasten hoses, lines and wiring harnesses to original vehicle lines and wiring harnesses using cable ties. Insulate loose wire ends and tie back. Connectors on electronic components must audibly snap into place during assembly.

Spray unfinished body areas, e.g. drilled holes, with anti-corrosion wax (Tectyl 100K).

Observe the instructions and guidelines of the respective vehicle manufacturer for demounting and mounting vehicle specific components.

The initial start-up is to be executed with the Webasto Thermo Test Diagnosis.

When installing a programmable control module (e.g. a PWM Gateway), the corresponding settings must be checked or adjusted.

3.2.1 Statutory regulations governing installation

The Thermo Top Evo heater has been type-tested and approved in accordance with ECE-R 10 (EMC) and ECE-R 122 (heater). The regulations of these guidelines are binding in the scope of the Directive 70/156/EEC and/or 2007/46/EC (for new vehicle models from 29/04/2009) and should also be observed in countries in which there are no special regulations.

The heater is licensed in accordance with paragraph 19, section 3, No. 2b of the StVZO (German Road Traffic Licensing Authority).

3.3 Safety

Qualifications of installation personnel

The installation personnel must have the following qualifications:

- Successful completion of Webasto training
- Corresponding qualification for working on technical systems

Regulations and legal requirements

The regulations from the heater's general installation and operating instructions must be observed.

3.3.1 Safety information on installation

Danger posed by live parts

- ▶ Prior to installation, disconnect the vehicle from the voltage supply.
- ▶ Make sure the electrical system is earthed correctly.
- ▶ Always comply with legal requirements.
- ▶ Observe data on type label.

Danger of fire and leaking toxic gases due to improper installation

- ▶ Vehicle parts in the vicinity of the heater must be protected against excessive heating by the following measures:
 - ⇒ Maintain minimum safety distances.
 - ⇒ Ensure adequate ventilation.
 - ⇒ Use fire-resistant materials or heat shields.

Danger due to sharp edges

- Lacerations
- Short circuit due to electrical wire damage
- ▶ Fit protectors on sharp edges.

3.4 Using this document

Before installing and operating the heater, read this installation documentation, the installation instructions of the heater, the operating instructions and supplementary sheets provided.

3.4.1 Explanatory Notes on the Document

There is an identification mark near the respective work step to allow you to quickly allocate the other applicable documents to the Webasto components to be installed:

Generally valid Webasto documentation	
Vehicle-specific installation documentation	
Webasto Comfort A/C control	
Webasto Standard A/C control	
Tank extracting device (e.g. FuelFix)	
Exhaust end fastener (EFIX)	
Combustion air intake silencer	
Spacer bracket (ASH)	

3.4.2 Use of symbols



DANGER

Type and source of the risk

Consequences: Failure to follow the instructions can result in death

► Actions to protect yourself against risks.



WARNING

Type and source of the risk

Consequences: Failure to follow the instructions can lead to serious or even fatal injuries

► Actions to protect yourself against risks.



CAUTION

Type and source of the risk

Consequences: Failure to follow the instructions can lead to minor injuries

► Actions to protect yourself against risks.



Type and source of the risk

Consequences: Failure to follow the instructions can lead to material damage

► Actions to protect yourself against risks.



Reference to the vehicle manufacturer's specific documents.



a note on a special technical feature

3.4.3 Work step identification marks

The ongoing work step is indicated on the outside top corner of the page:

Mechanical system	Electrical System	High-voltage	Coolant
Combustion air	Fuel	Exhaust gas	Software

3.4.4 Orientation aid

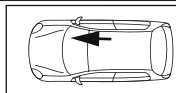

The arrow indicates the position on the vehicle and the viewing angle

3.4.5 Use of highlighting

Highlight	Explanation
►	Necessary action
⇒	Result of an action
1 / 12 / a1 / A	Position numbers for the image descriptions
① / ⑫	Position numbers for the image descriptions for electrical wires and wiring harnesses and coolant hose sections

4 Technical Information

Dimension specifications

- All dimensions specified in mm

Tightening torque specifications

- Tightening torque values of 5x13 heater bolts and 5x11 heater stud bolts = 8Nm
- Tightening torque values of 5x15 retaining plate of water connection piece bolts = 7Nm
- 5x12 bolt tightening torque of 2-part heater bracket = 6Nm
- Tighten other bolt connections in accordance with manufacturer's instructions or in accordance with state-of-the-art-technology

Specified temperature for fabric heat shrink tubing

- Shrink temperature max. 230°C

Necessary special tools

- Hose clamp pliers for self-clamping hose clamps
- Hose clamp pliers for Clic hose clamps of type W
- Hose clamping pliers
- Hose cutter
- Automatic wire stripper 0.2 - 6 mm²
- Crimping pliers for cable lugs 0.5 – 10 mm²
- Crimping pliers for tab connector 0.14 – 6 mm²
- Crimping pliers for connector 0.25 – 6 mm²
- Torque wrench for 2.0 - 10 Nm
- Deep-hole marker
- Metric thread-setter kit
- Webasto Thermo Test Diagnosis with current software
- Nibbler for sheet steel Knipex 9055280 EAN

5 Preparing measures

5.1 Vehicle preparation



Further information can be found in the vehicle manufacturer's technical documentation.

- ▶ Open the fuel tank cap
- ▶ Ventilate the fuel tank
- ▶ Close the fuel tank cap again
- ▶ Depressurise the cooling system
- ▶ Drain off the coolant
- ▶ Disconnect the battery (in the boot)
- ▶ Remove the right and left front wheel
- ▶ Remove the right wheel well trim completely
- ▶ Remove the front part of the front wheel well trim on the left (2 parts)
- ▶ Remove the lower section of the front wheel-well inner panel on the left
- ▶ Remove the brake air duct on the left
- ▶ Remove the lower engine cover completely
- ▶ Remove the underbody trim on the right
- ▶ Remove the underbody trim from the fuel tank
- ▶ Remove the strut brace on the front right
- ▶ Remove the resonator and air filter box
- ▶ Open the tank fitting service lid on the left

5.2 Heater preparation



Observe the general installation instructions of the heater.

- ▶ Remove years that do not apply from the type and duplicate label.
- ▶ Attach the duplicate label (type label) in the appropriate place in the engine compartment.

6 Installation overview

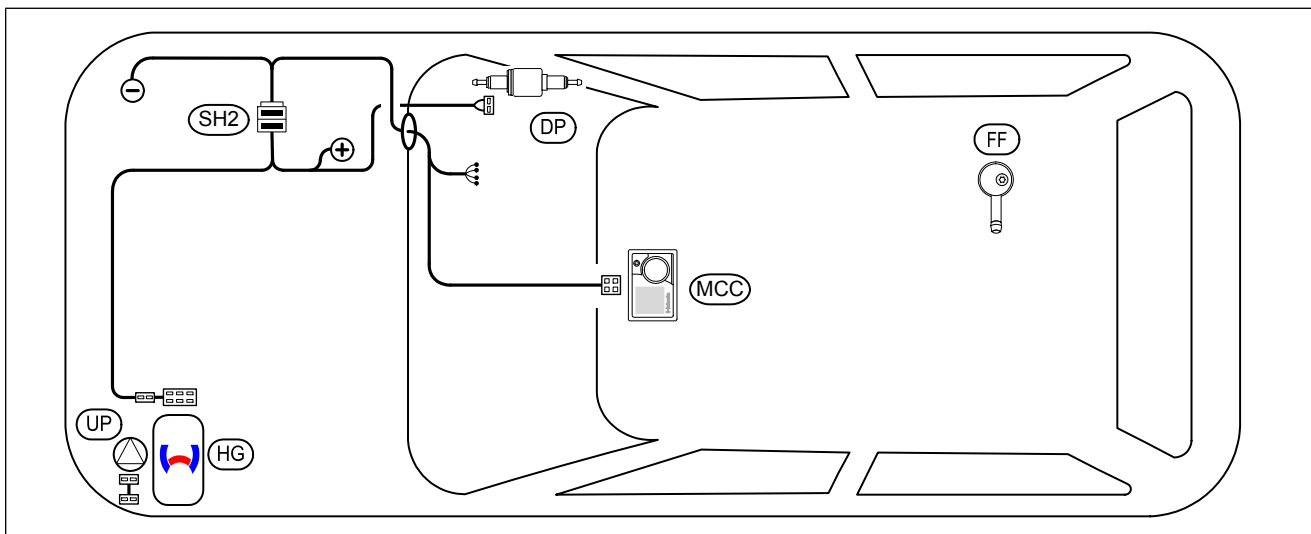
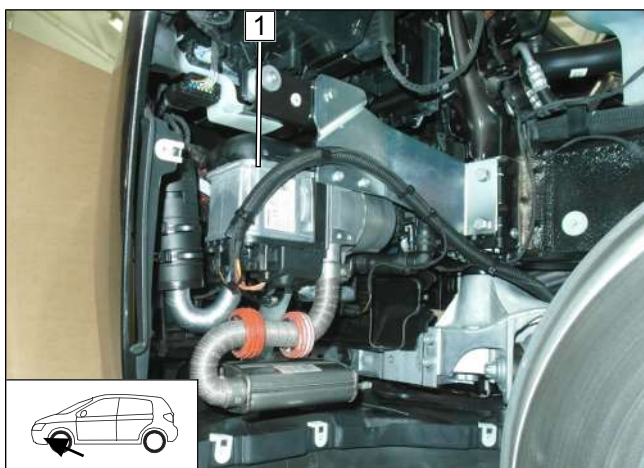

Fig. 1

Legend to installation overview

Abbreviation	Component
DP	Fuel pump
FF	FuelFix
HG	Heater
MCC	MultiControl CAR
SH2	Fuse holder of engine compartment
UP	Coolant pump

Heater installation location



1 Heater

Fig. 2



7 Mechanical system

7.1 Preparing installation location

Inserting rivet nut

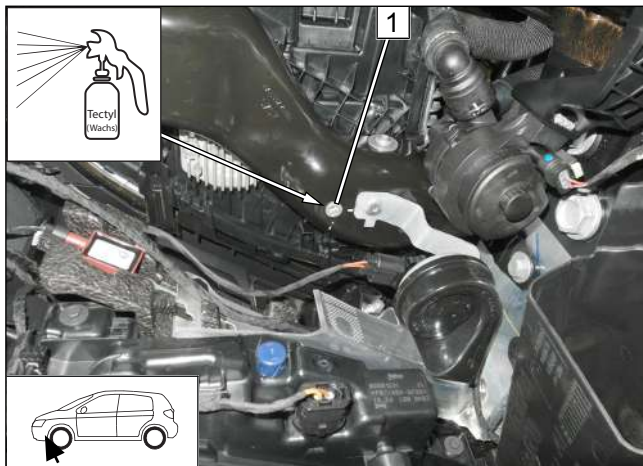

Fig. 3

- ▶ Drill out original vehicle hole at position **1** to 9 mm dia.

1 Rivet nut

Cutting original vehicle hose

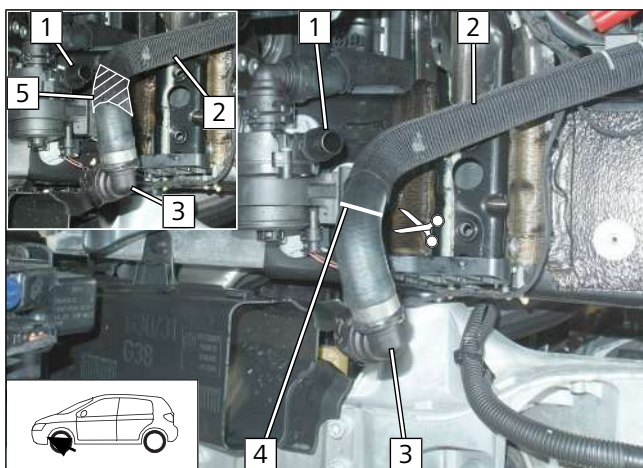

Fig. 4

- ▶ Disconnect original vehicle quick-release coupling **3** from connection piece of original vehicle coolant pump **1** and remove fabric protective hose at position **5** as shown.

2 Heat exchanger inlet hose

4 Cutting point

Preparing original vehicle quick-release coupling

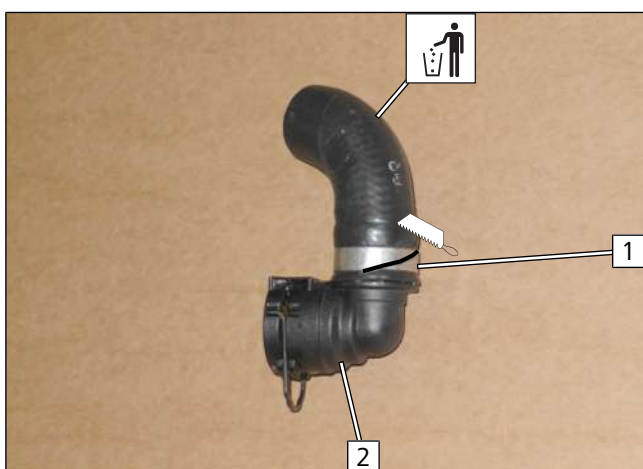

Fig. 5

- ▶ Cut original vehicle clamp **1** carefully as shown. Quick-release coupling **2** will be reused.



Cutting hoses to length

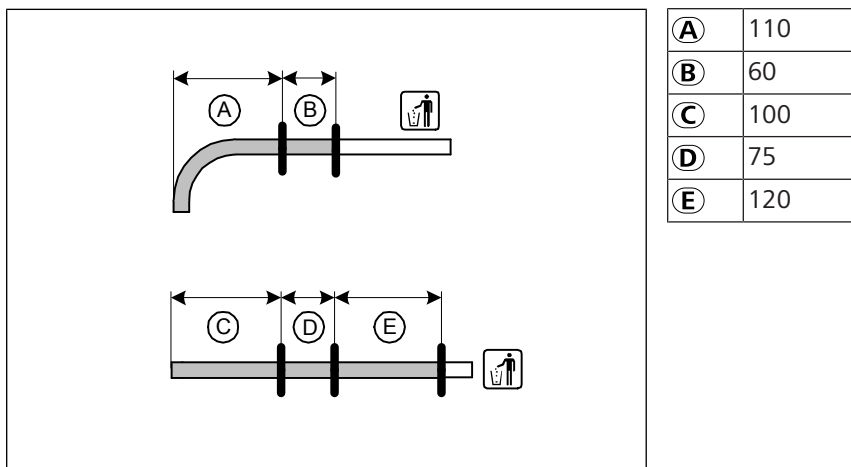

Fig. 6

Installing hose (E)

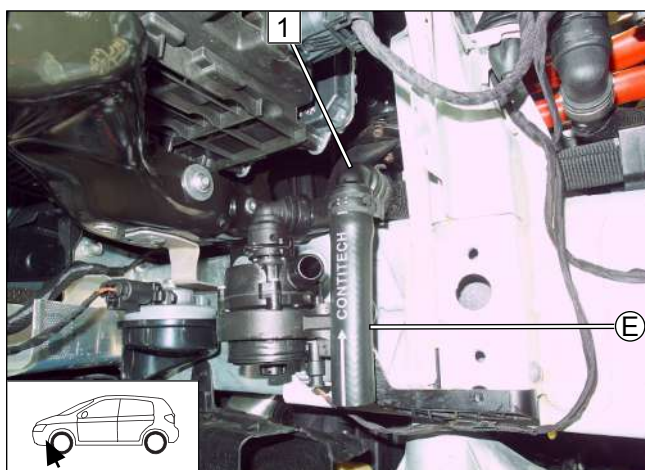

Fig. 7



All spring clips, 25mm dia.

- 1** 90°, 18x18mm connecting pipe

Drilling holes

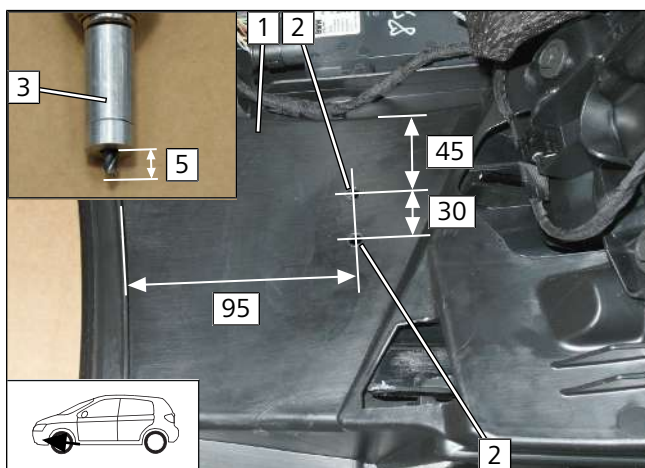

Fig. 8



Danger of damage to components

- ▶ Limit the drilling depth to max. 5 mm with appropriate means **3**.

- 1** Bumper trim
- 2** 6mm dia. hole



Mounting eyelet cable tie

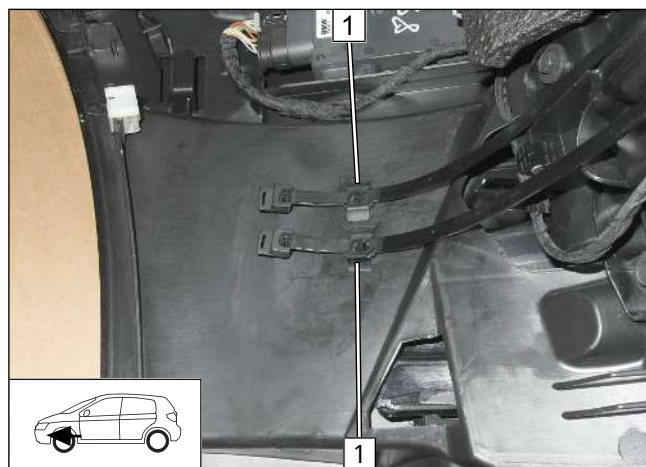

Fig. 9

- 1 Eyelet cable tie

7.2 Premounting heater

Mounting water connection piece

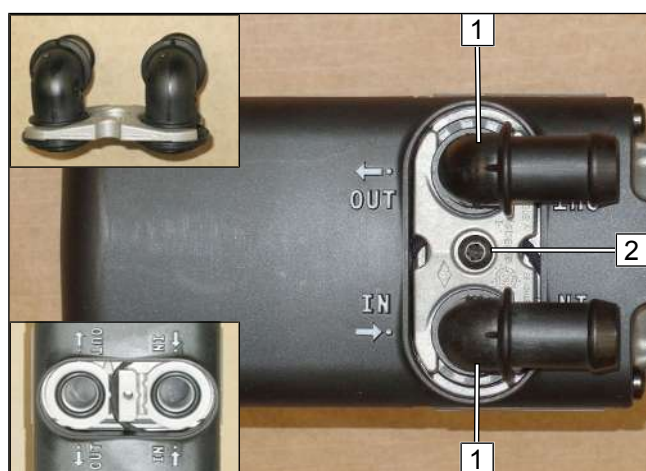

Fig. 10



Observe the general installation instructions of the heater.

- 1 90° water connection piece, seal
- 2 5x15 self-tapping bolt, water connection piece retaining plate

Mounting moulded hose

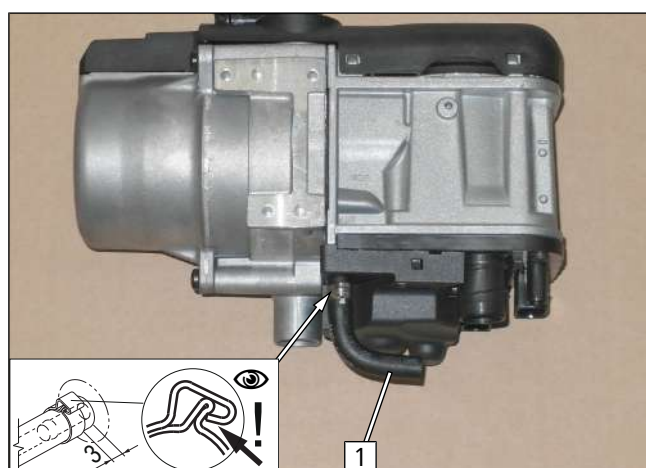
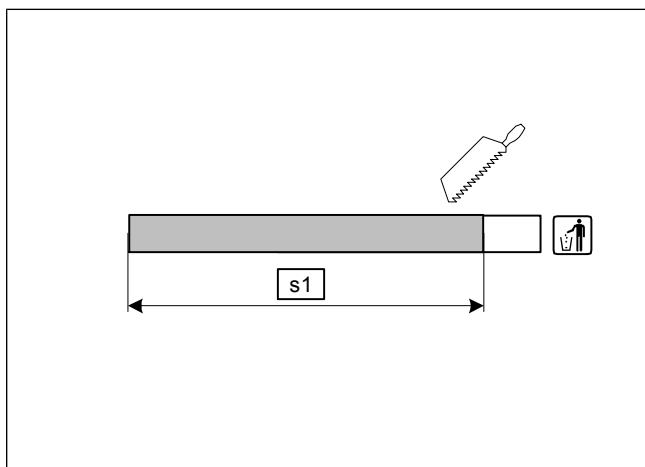

Fig. 11

- 1 90° moulded hose, 10mm dia. clamp



Cutting combustion air pipe to length



s1 150

Fig. 12

Mounting combustion air intake silencer

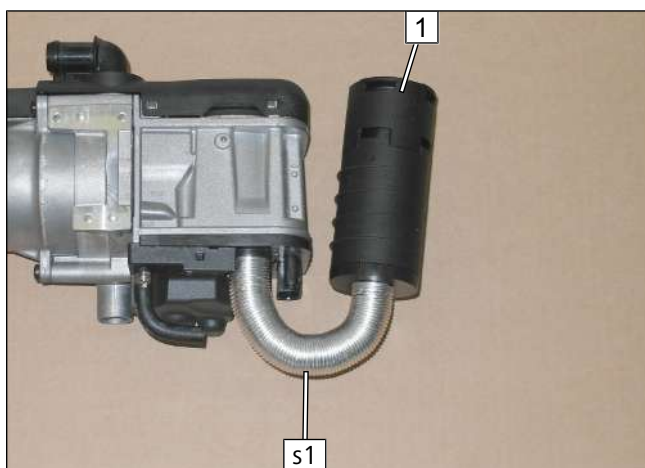

Observe the installation instructions of the combustion air intake silencer.

1 Combustion air intake silencer

Fig. 13

Mounting bracket **A**

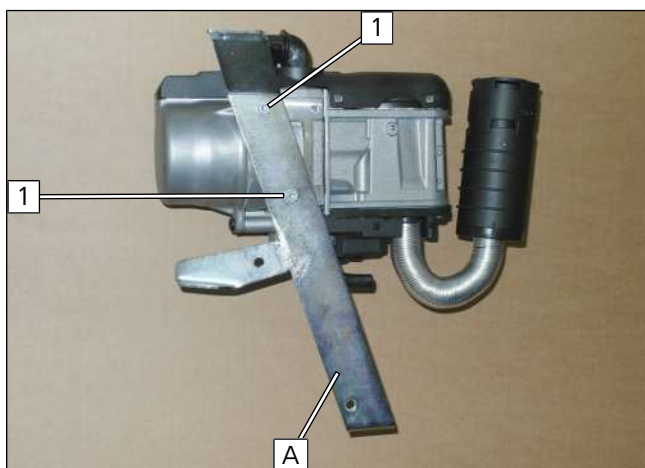

1 Mount 5x13 self-tapping bolt loosely

Fig. 14



Cutting exhaust pipe to length

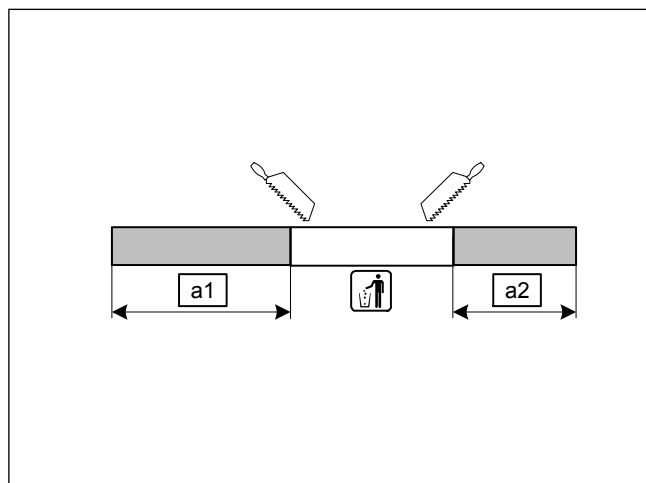

a1 280

a2 180

Fig. 15

Preparing exhaust pipe **a1**

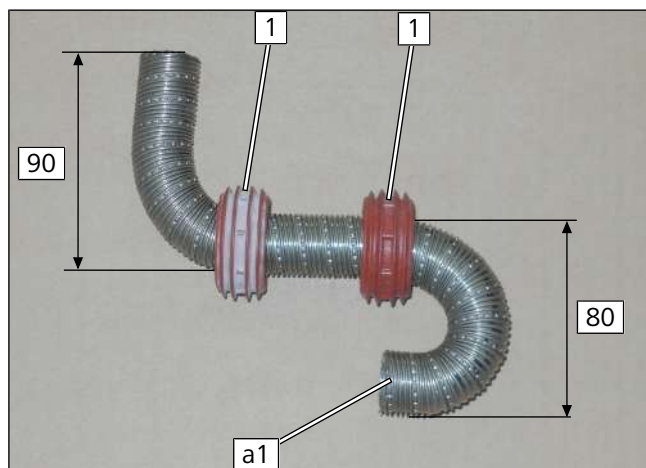

► Bend exhaust pipe **a1** as shown.

1 ASH

Fig. 16

Preparing exhaust pipe **a2**

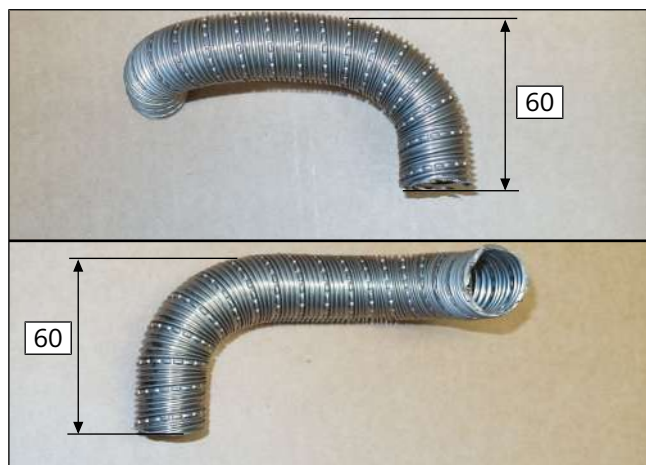

► Bend exhaust pipe **a2** as shown.

Fig. 17



Mounting exhaust silencer

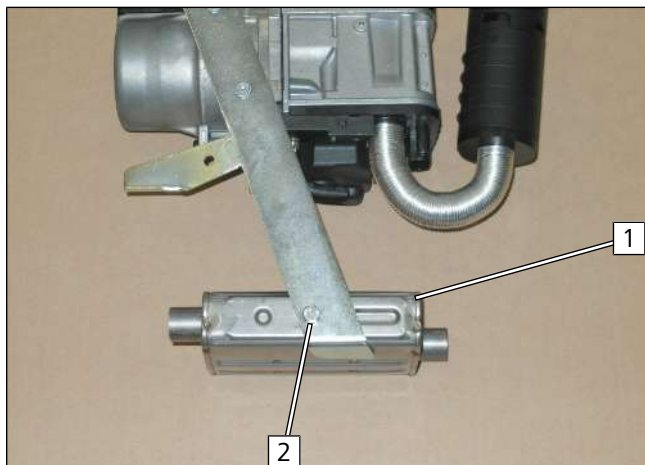

Fig. 18

- 1 Exhaust silencer
- 2 M6x16 bolt, spring lockwasher

Installing exhaust pipe a1

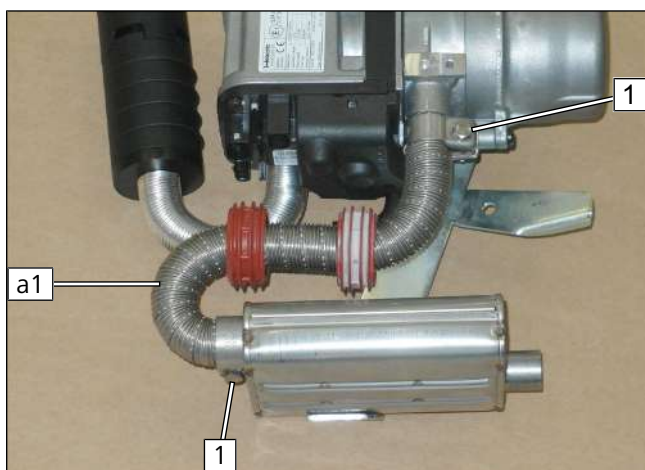

Fig. 19

- 1 Hose clamp

Mounting exhaust pipe a2

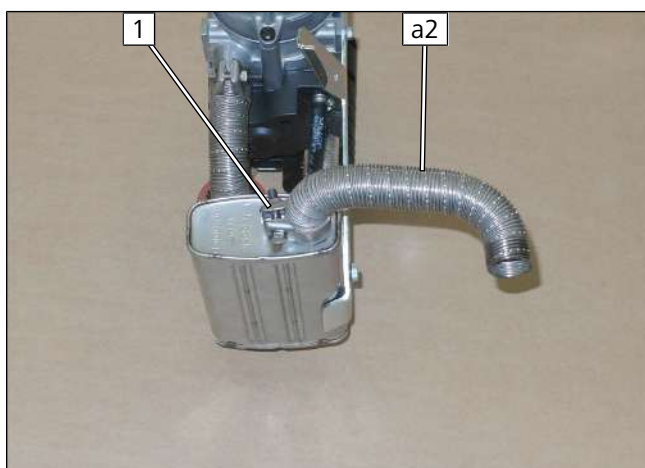

Fig. 20

- 1 Hose clamp



Mounting bracket **B**

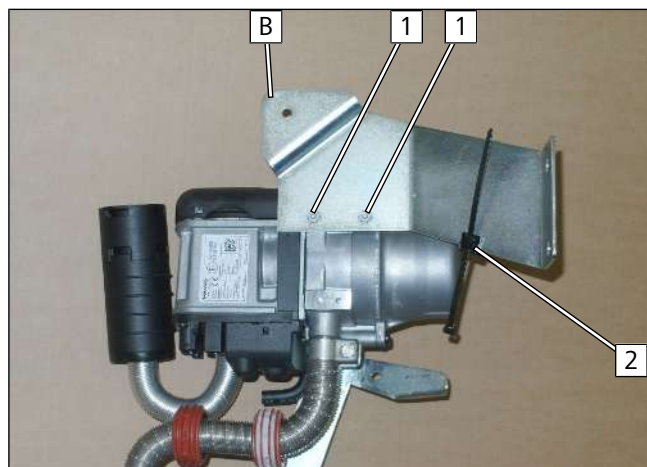

Fig. 21

- 1** Mount 5x13 self-tapping bolt loosely
- 2** Edge clip cable tie

Preparing coolant pump mount

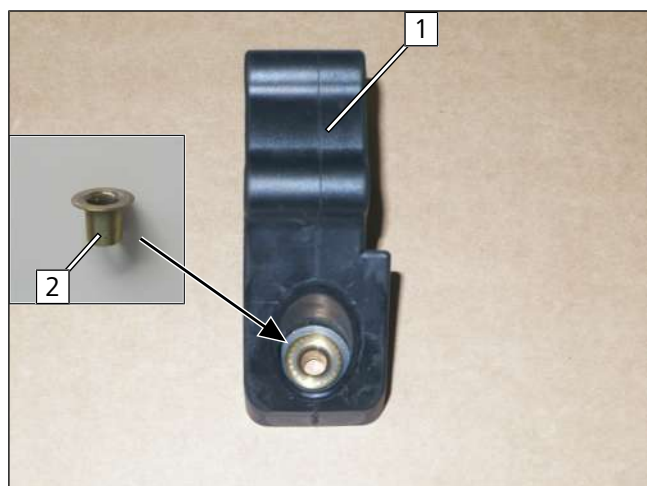

Fig. 22

- 1** UP mount
- 2** Sleeve

Mounting coolant pump

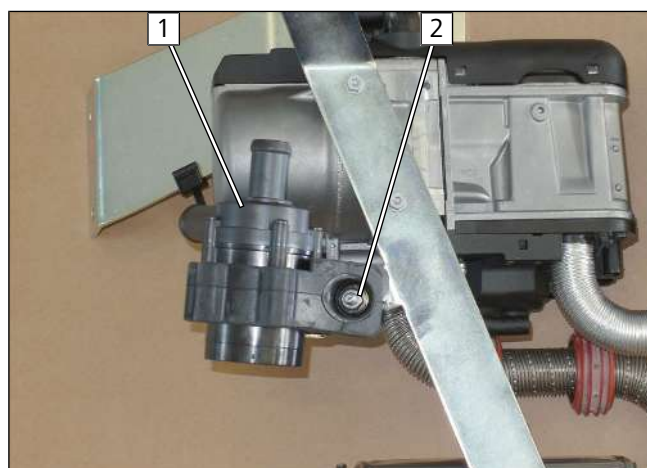

Fig. 23

- 1** Coolant pump
- 2** M6x25 bolt, bracket **A**, coolant pump mount, flanged nut



Mounting hoses **B** and **C**

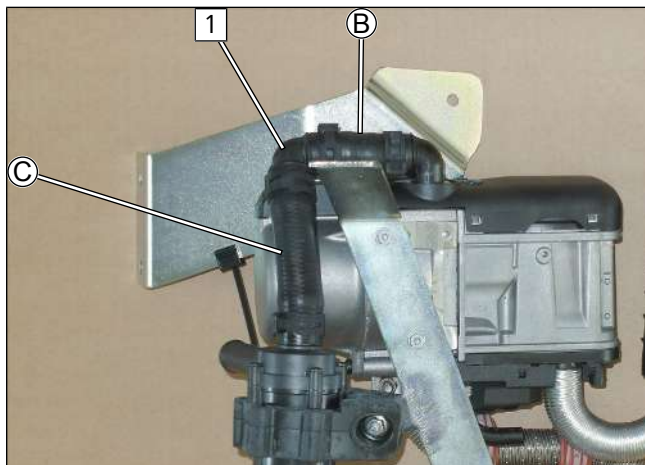

Fig. 24



All spring clips, 25mm dia.

- 1 90°, 18x18mm connecting pipe

Mounting hose **D**

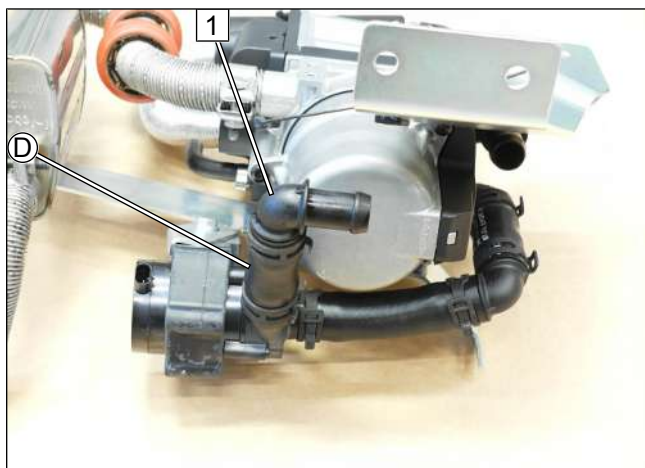

Fig. 25



All spring clips, 25mm dia.

- 1 90°, 18x18mm connecting pipe

Mounting hose **A**

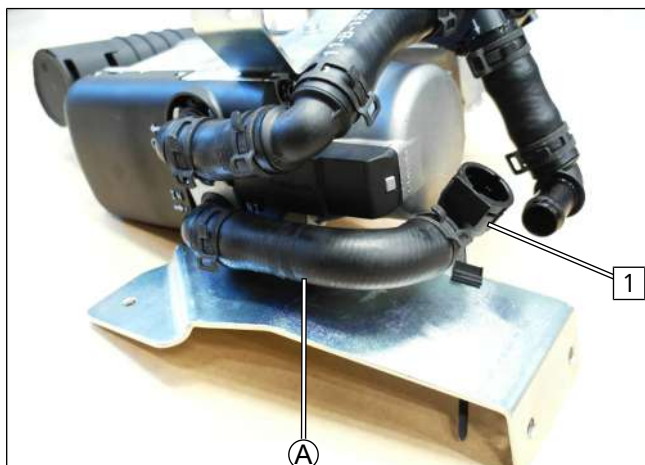

Fig. 26



All spring clips, 25mm dia.

- 1 Original vehicle quick-release coupling



Mounting coolant pump wiring harness



Fig. 27

- 1 Coolant pump wiring harness connector

7.3 Heater installation part 1

Fastening bracket B

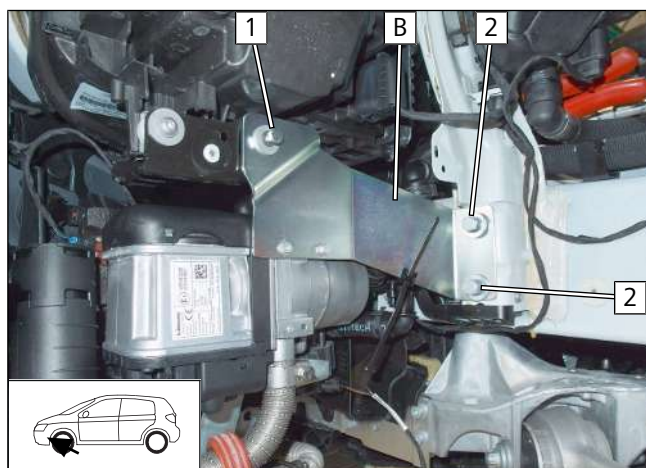

Fig. 28

- 1 Mount M6x20 bolt, spring lockwasher, 22mm dia. large diameter washer, original vehicle thread loosely
- 2 Mount M8x20 bolt, spring lockwasher, 22mm dia. large diameter washer, original vehicle thread loosely

Fastening bracket A

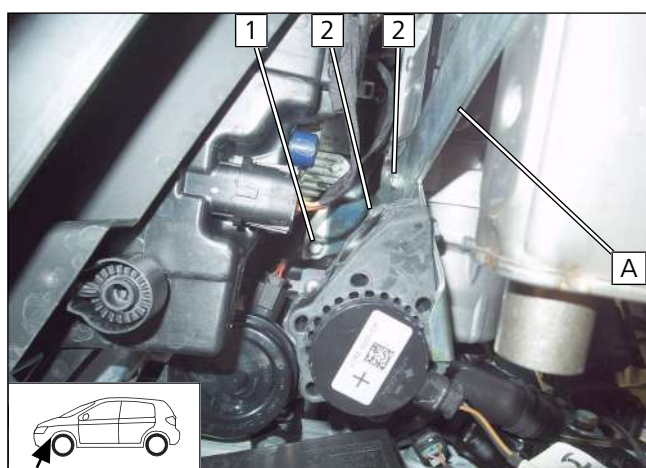

Fig. 29

- 1 Mount M6x20 bolt, spring lockwasher, 18mm dia. large diameter washer, original vehicle thread loosely
- 2 Tighten self-tapping bolts



7.4 Hose routing diagram

'Inline' coolant circuit

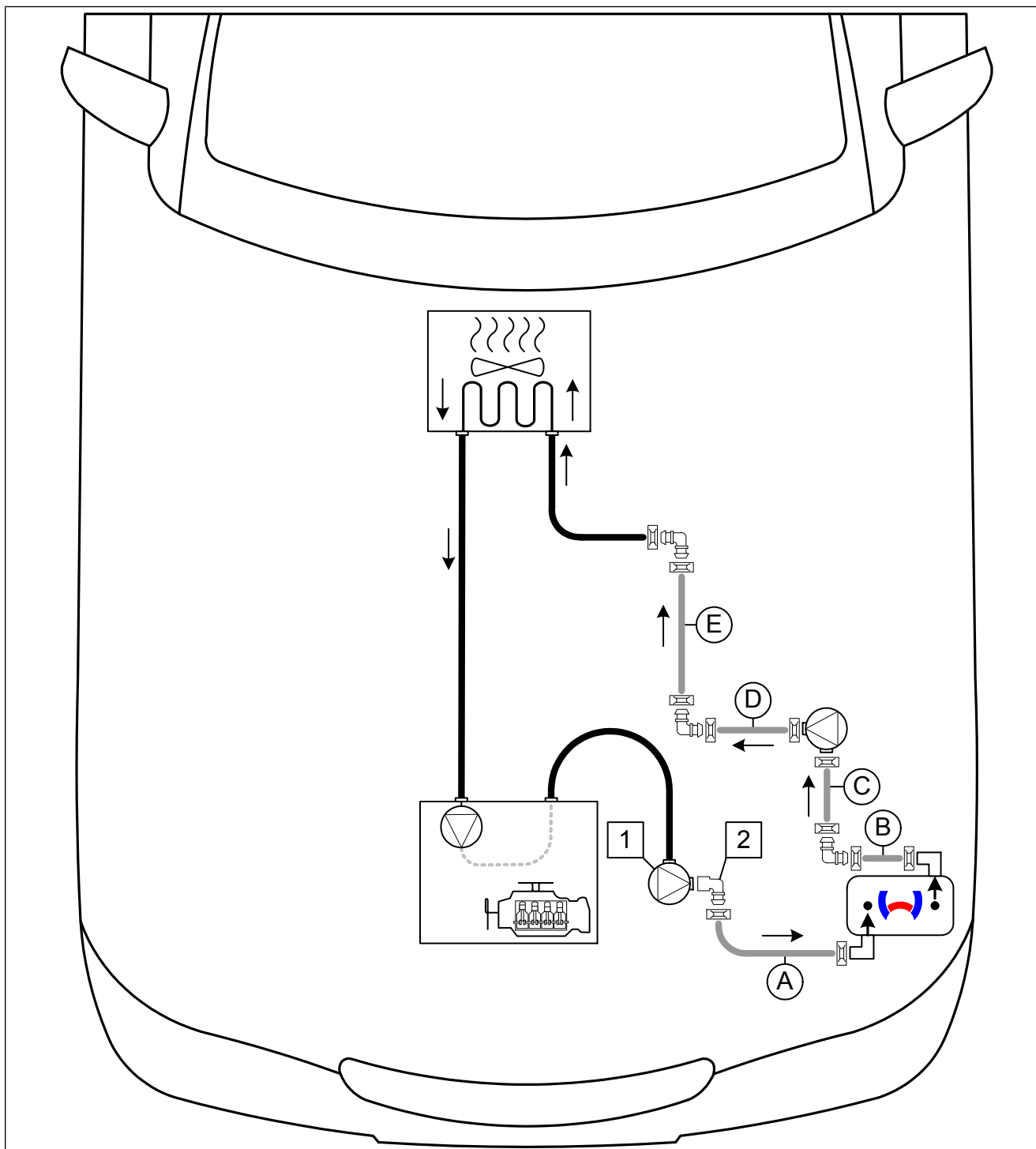

Fig. 30

► All spring clips  = 25mm dia.

► All connecting pipes  = 18x18mm dia.

1 Original vehicle coolant pump

2 Original vehicle quick-release coupling



7.5 Heater installation part 2

Connecting hoses **A**, **D** and **E**

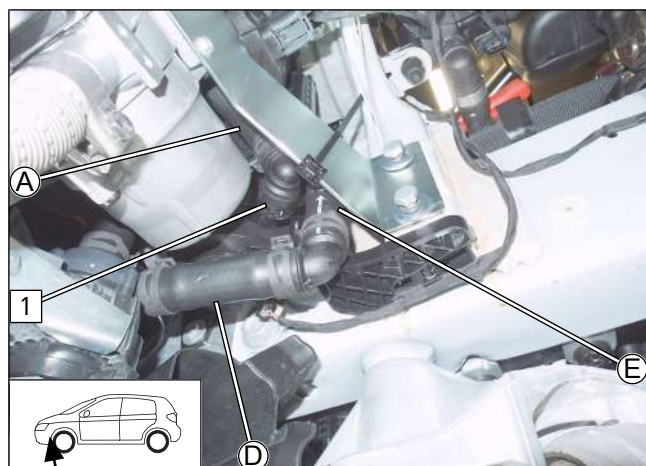

Fig. 31

- ▶ Connect original vehicle quick-release coupling **1** to original vehicle coolant pump.
- ▶ Connect hoses **D** and **E** as shown.

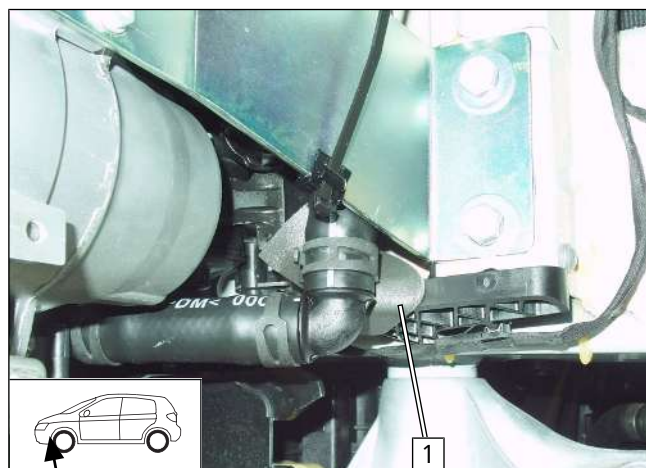

Fig. 32

- ▶ Stick on self-adhesive foam **1** as rub protection as shown.

Tightening bracket **B**

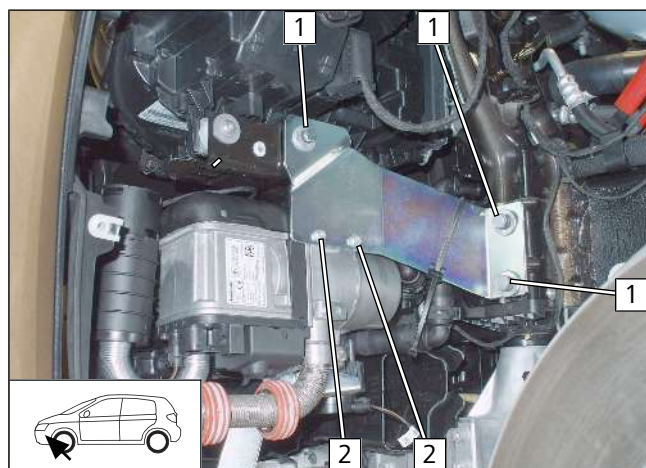

Fig. 33



- ▶ Tighten all screw connections **1** of bracket **B** and heater **2**.



Fastening combustion air intake silencer

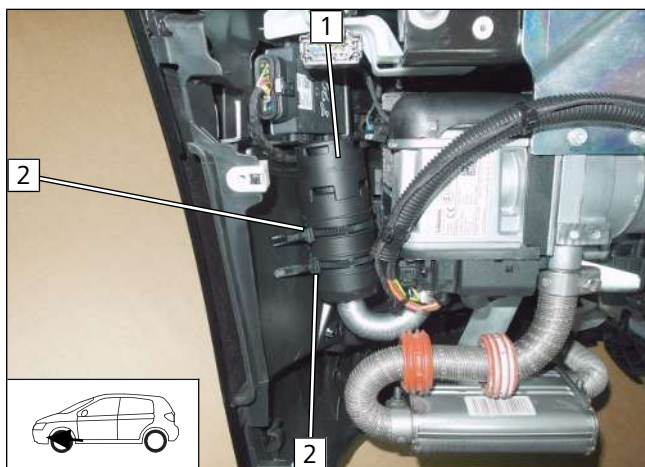

- 1** Combustion air intake silencer
- 2** Tighten eyelet cable tie

Fig. 34



8 Electrical system of engine compartment

Replacing fuse F2

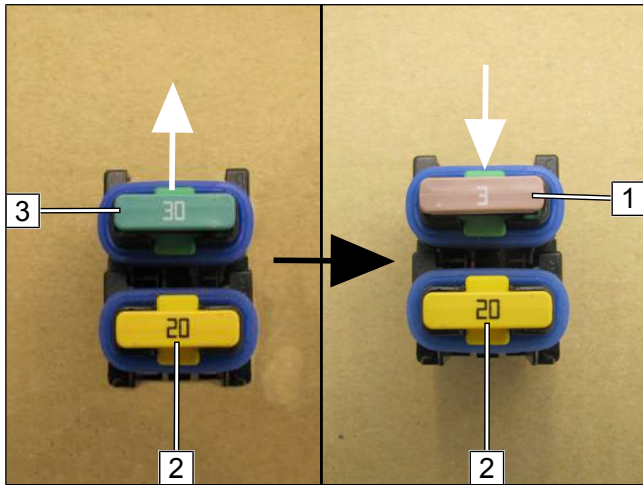

Fig. 35

► Replace 30A passenger compartment main fuse F2 **3** with 3A fuse **1**.

2 Fuse F1: 20A

Preparing heater wiring harness and fuel line

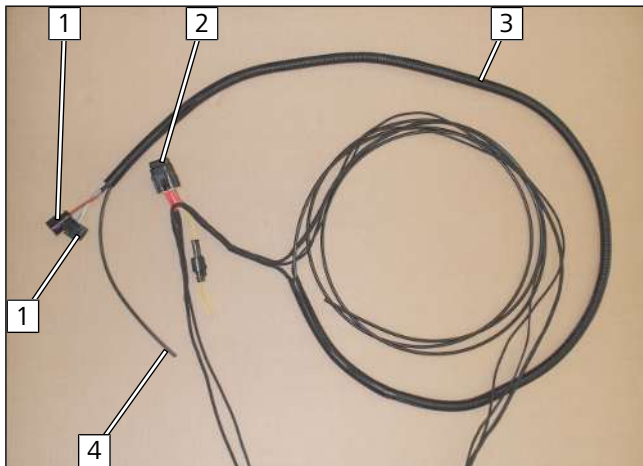

Fig. 36

► Let fuel line **4** protrude by about 200mm from 13mm dia. corrugated tube **3**.

1 Heater wiring harness connector

2 SH2

Mounting heater wiring harness

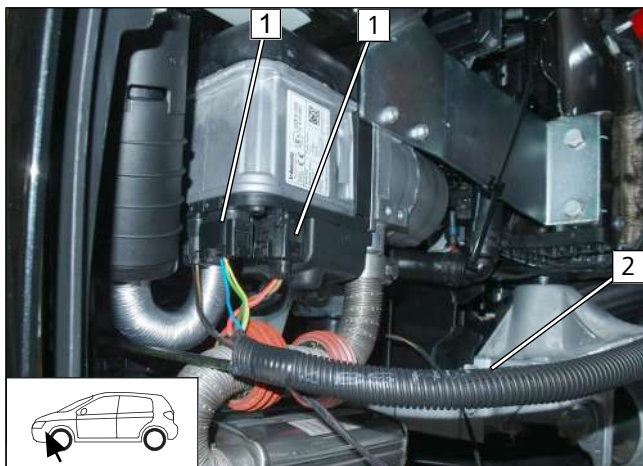

Fig. 37

1 Heater wiring harness connector



Connecting fuel line

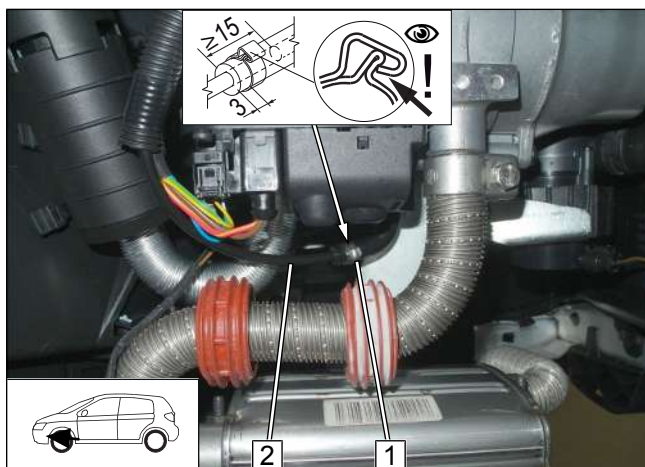

Fig. 38

- 1 10mm dia. clamp
- 2 Fuel line

Routing wiring harness

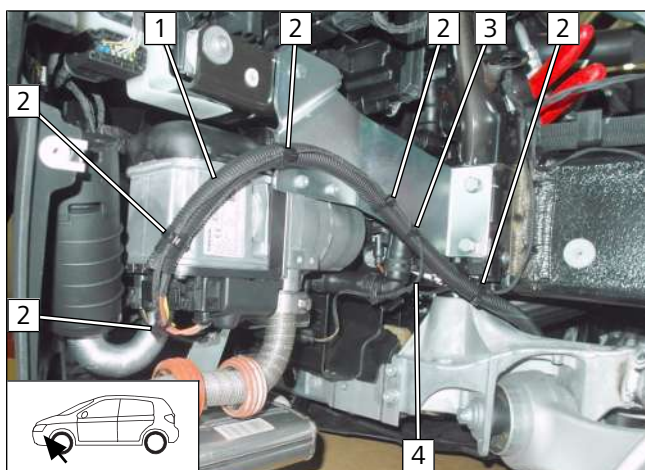

Fig. 39

- ▶ Route corrugated tube **1** with heater wiring harness, fuel pump wiring harness and fuel line as shown in the engine compartment and secure it using cable ties **2**.
- ▶ Attach coolant pump wiring harness **4** together with corrugated tube.
 - 3** Edge clip cable tie

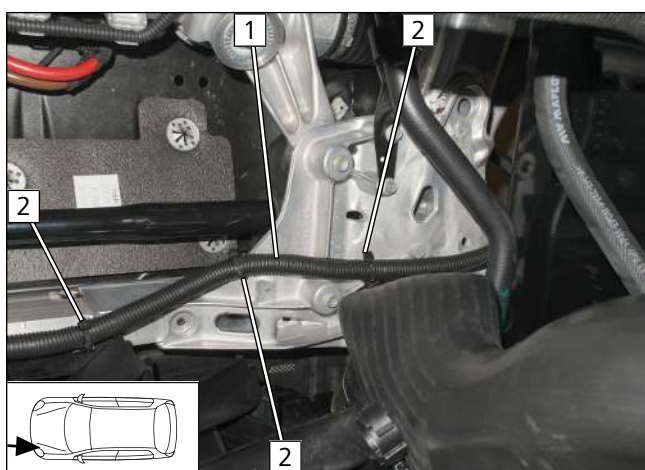
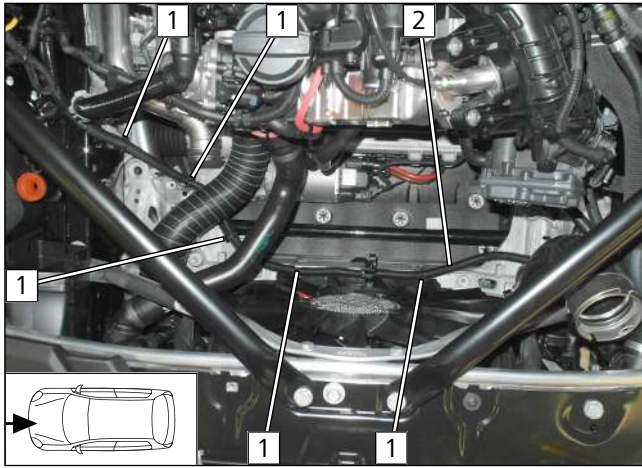

Fig. 40

- ▶ Route corrugated tube **1** with heater wiring harness, fuel pump wiring harness and fuel line as shown and secure it using edge clip cable ties **2**.



Routing wiring harness 2.0D



- ▶ Route corrugated tube **2** with heater wiring harness, fuel pump wiring harness and fuel line as shown and secure it using edge clip cable ties **1**.

Fig. 41

Routing wiring harness 3.0D

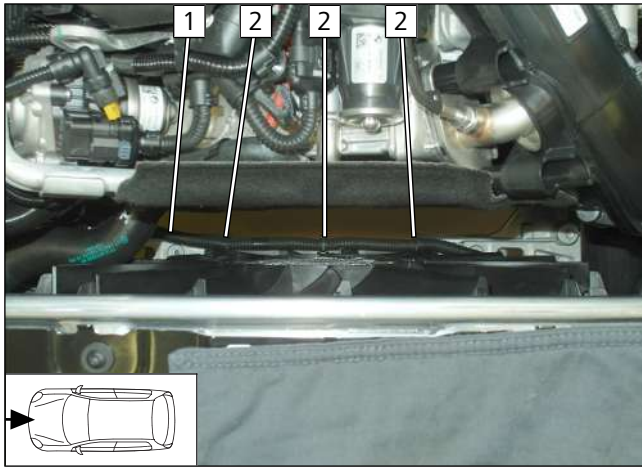

- ▶ Route corrugated tube **1** with heater wiring harness, fuel pump wiring harness and fuel line as shown and secure it using edge clip cable ties **2**.

Fig. 42

All vehicles

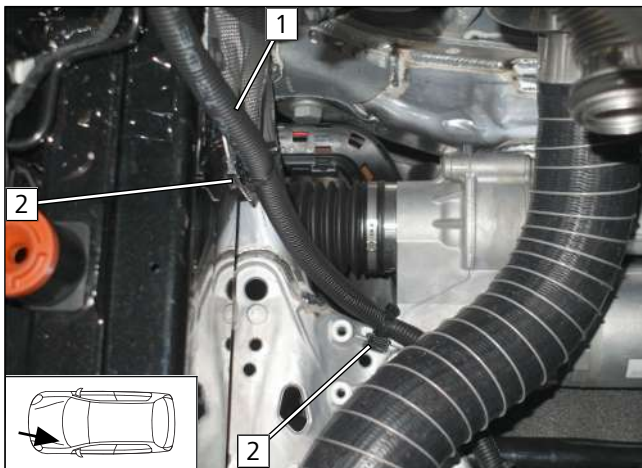

- ▶ Route corrugated tube **1** with heater wiring harness, fuel pump wiring harness and fuel line as shown and secure it using edge clip cable ties **2**.

Fig. 43



Drilling out angle bracket

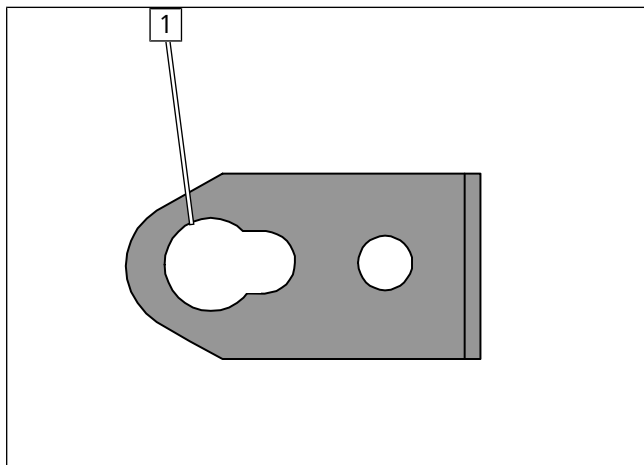

Fig. 44

- 1 Drill out angle bracket to 12.5mm dia

Premounting retaining plate of SH2

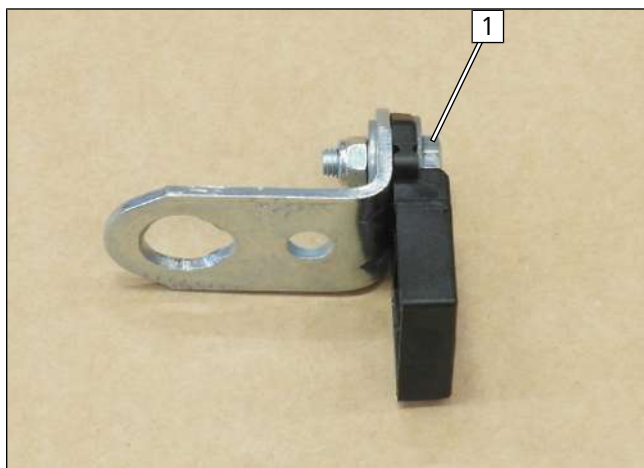

Fig. 45

- 1 M5x16 bolt, large diameter washer, retaining plate of SH2, angle bracket, large diameter washer, nut

Mounting SH2

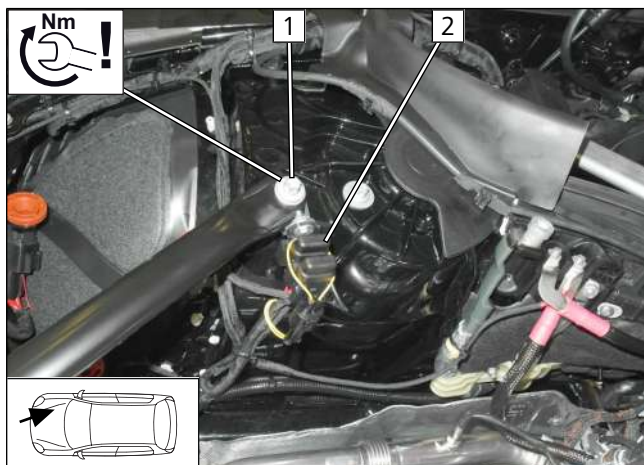

Fig. 46

- Position premounted angle bracket at position **1** between strut and strut brace.

- 1 Original vehicle bolt
- 2 Fuse F1 and F2



Connecting positive wire

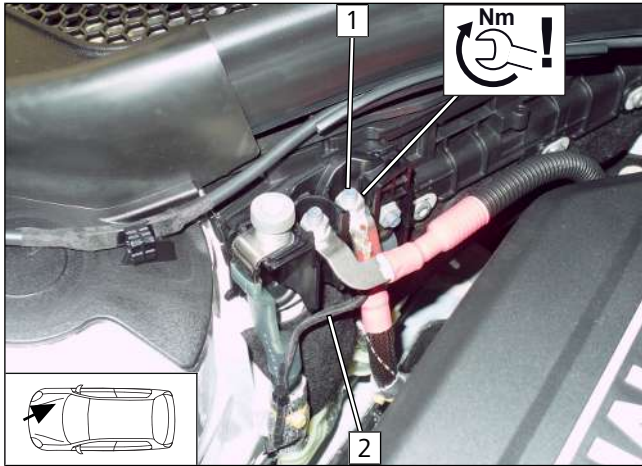

Fig. 47

- 1 Original vehicle positive support point
- 2 Positive wire

Connecting earth wire

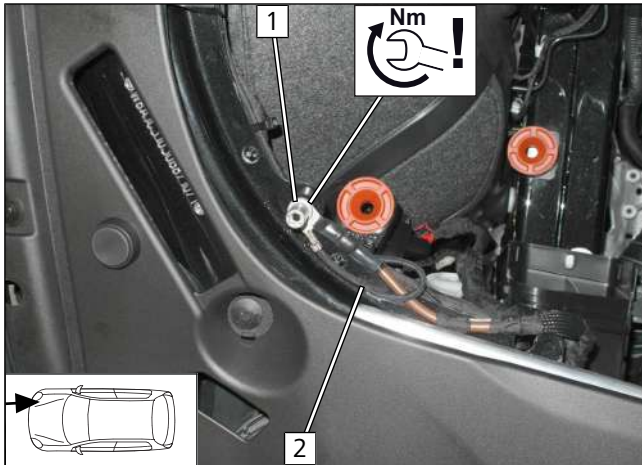

Fig. 48

- 1 Original vehicle earth support point
- 2 Earth wire

Routing wiring harness

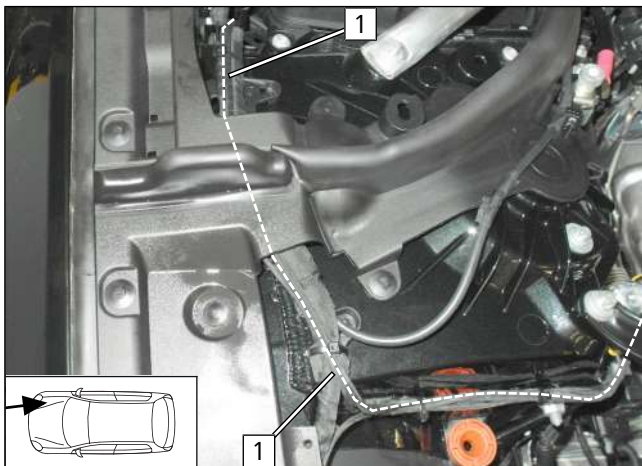
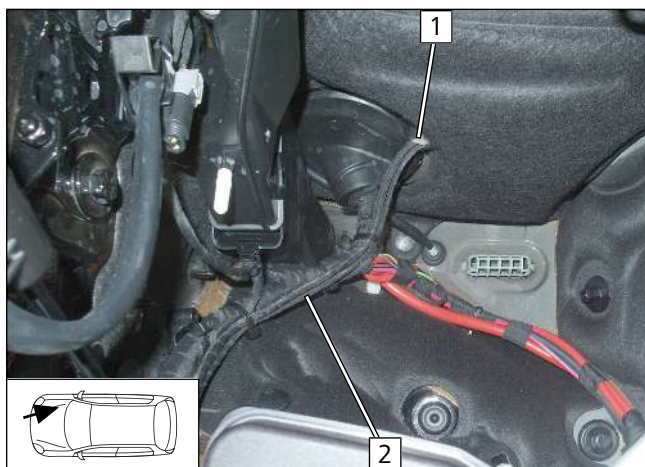

Fig. 49

- Route passenger compartment and control element wiring harnesses 1 to the passenger compartment pass through and secure them using cable ties.



Passenger compartment pass through



- 1 Passenger compartment pass through
- 2 Passenger compartment and control element wiring harnesses

Fig. 50



9 Fuel



DANGER

Risk of fire and explosion due to leaking fuel and escaping fuel vapours.

The Incorrect installation of the fuel extractor can cause damage and fire.

- ▶ Avoid electrostatic discharges and open fire.
- ▶ When working on the fuel system, ensure sufficient ventilation and bleeding.
- ▶ Open the fuel tank cap of the vehicle.
- ▶ Ventilate the fuel tank
- ▶ Re-close the tank lock.
- ▶ Catch any fuel running off with an appropriate container.



Danger of damage to components

- ▶ Install fuel line and fuel pump wiring harness so that they are protected against stone impact.
- ▶ Provide rub protection for fuel line and wiring harness in areas where there are sharp edges.

Dismantling fuel pump connector X7

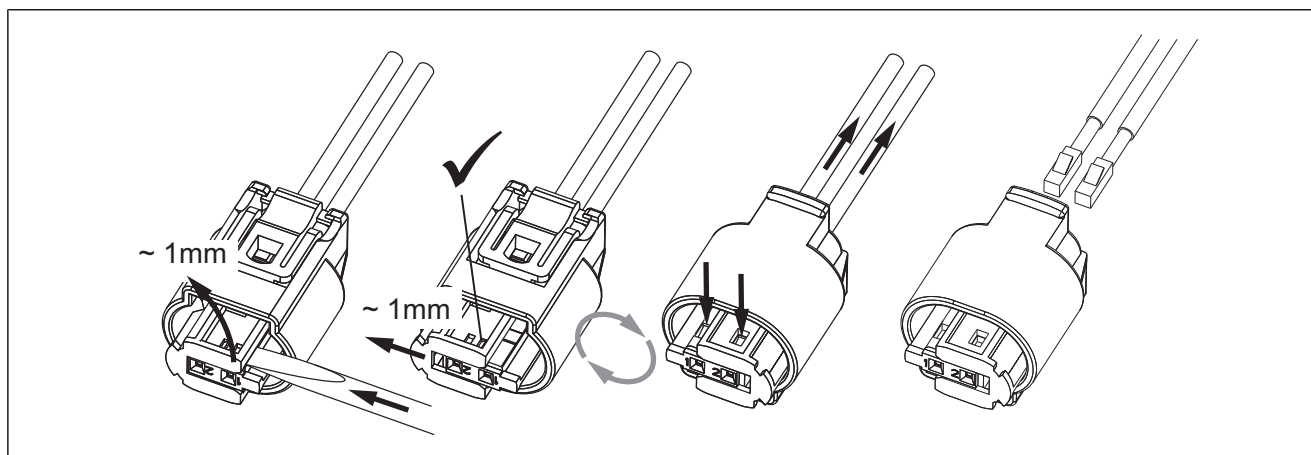
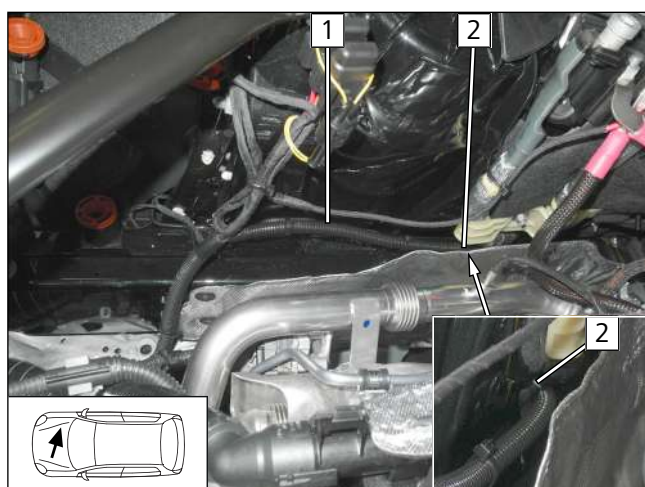

Fig. 51

9.1 Routing fuel line

Routing corrugated tube



- ▶ Draw fuel line and fuel pump wiring harness into 10mm dia. corrugated tube.

- 2** Pass through to wheel well

Fig. 52

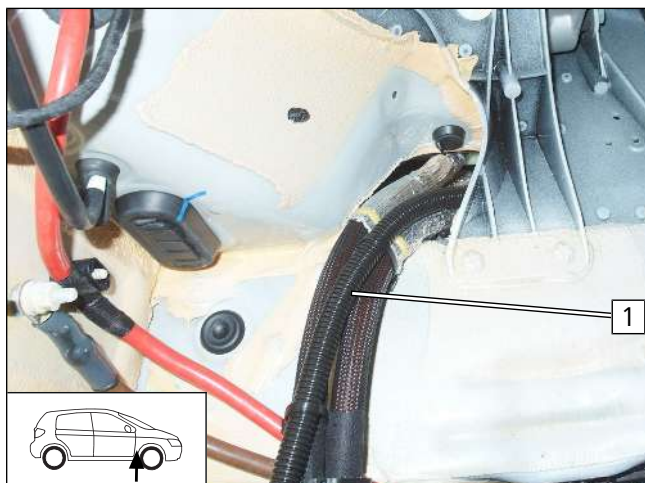

Fig. 53

- Route corrugated tube **1** with fuel line and fuel pump wiring harness to the installation location of the fuel pump on original vehicle lines.

Bending perforated bracket

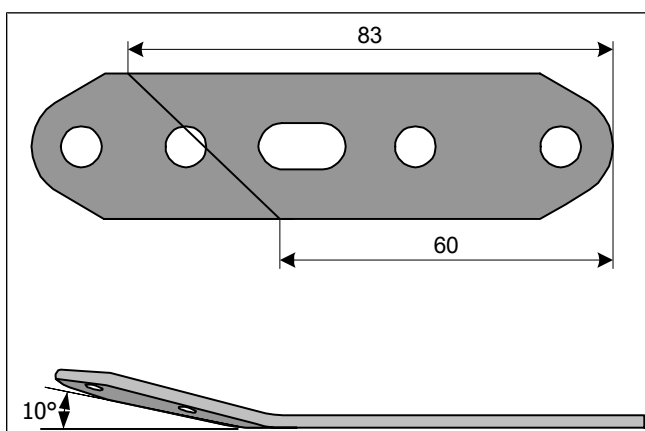

Fig. 54

Premounting fuel pump

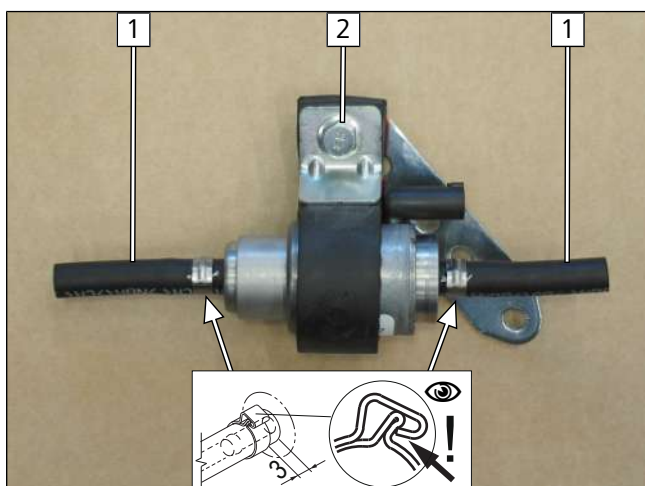

Fig. 55

- 1** Hose section, 10mm dia. clamp
- 2** M6x25 bolt, support angle bracket, fuel pump mount, perforated bracket, flanged nut



Mounting fuel pump

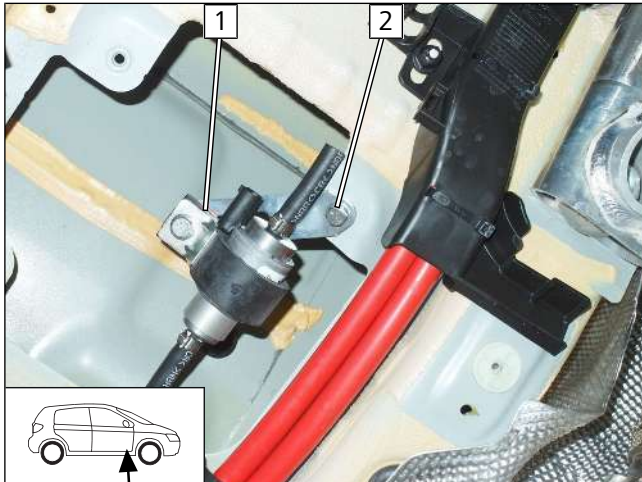

Fig. 56



► After fastening, align fuel pump horizontally with retaining plate by bending the bracket.

- 1 Premounted fuel pump
- 2 M6x20 bolt, spring lockwasher, perforated bracket, original vehicle thread

Connecting fuel pump

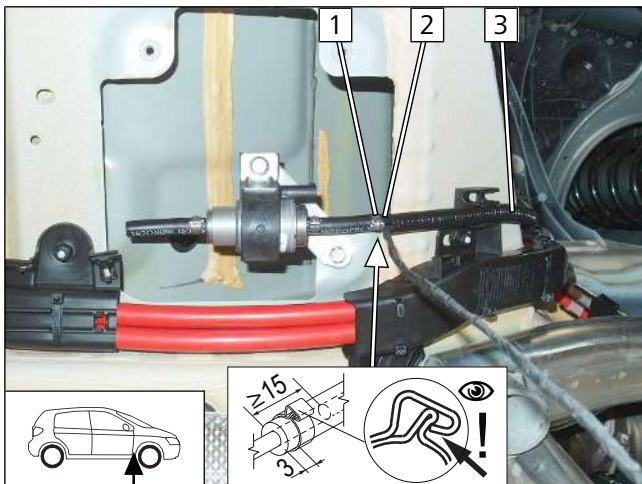

Fig. 57

- 1 10mm dia. clamp
- 2 Fuel line
- 3 Corrugated tube with fuel line and fuel pump wiring harness

Mounting fuel pump connector X7

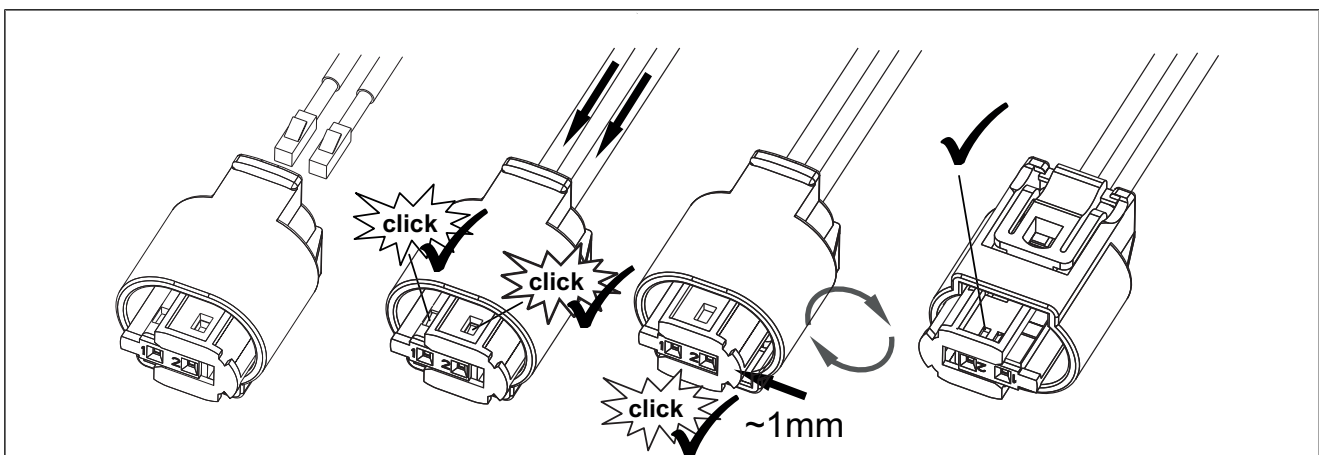

Fig. 58

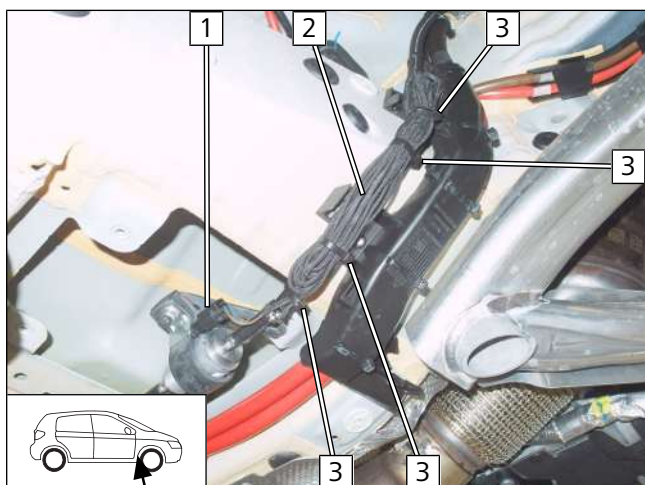

Fig. 59

- 1 Fuel pump wiring harness, connector X7 mounted
- 2 Rest of the fuel pump wiring harness
- 3 Cable tie

9.2 Installing FuelFix

Preparing drilling template

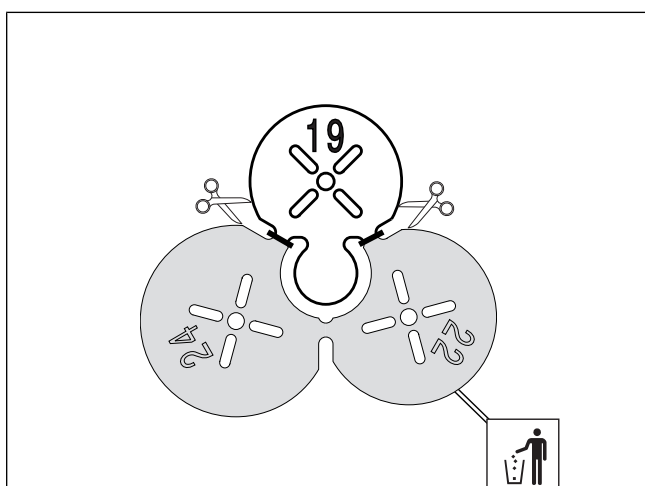

Fig. 60

View of tank fitting

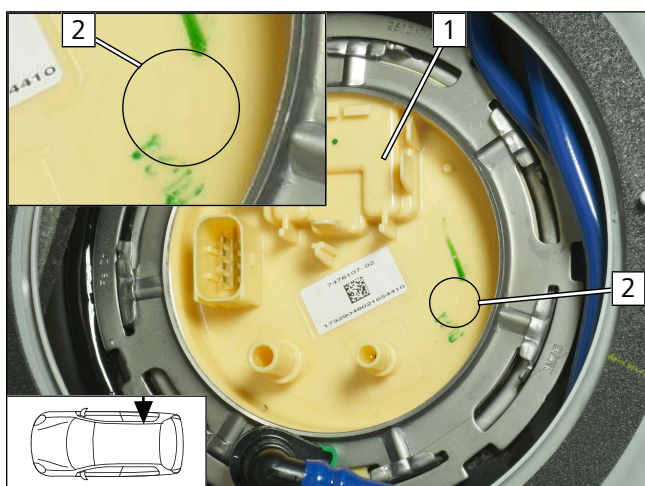

Fig. 61

- 1 Tank fitting
- 2 Embossed area on tank fitting



Copying hole pattern

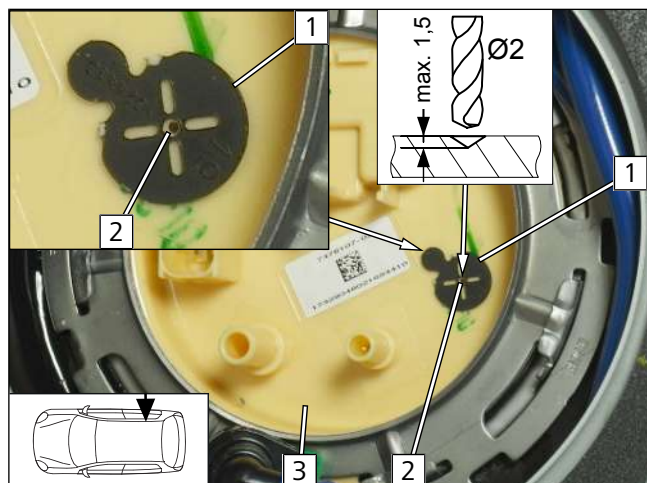

Fig. 62



Observe the installation instructions of the tank extracting device.

► Work steps F1, F2

- 1 Position 19mm dia. drilling template as shown in Fig. on the embossed area
- 2 2mm dia. centring hole
- 3 Tank fitting

Hole for FuelFix



Fig. 63



DANGER

Risk of fire and explosion due to leaking fuel and escaping fuel vapours.

► Work step F3

- 1 Hole made with provided drill

Inserting FuelFix

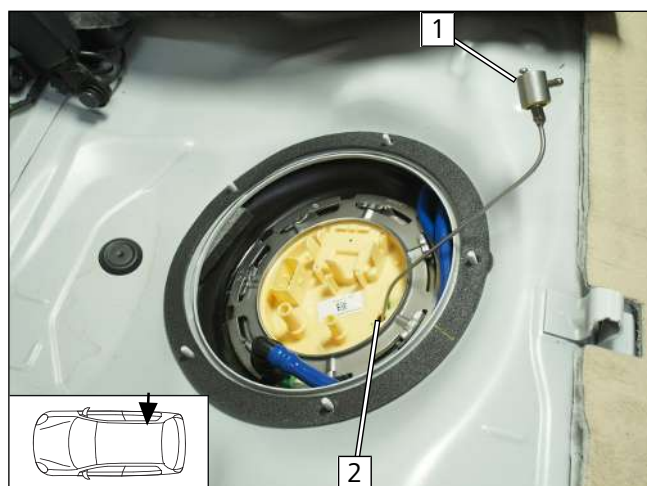

Fig. 64

► Work steps F4, F5

- Bend FuelFix 1 as shown in template and cut to length. Insert in hole 2.

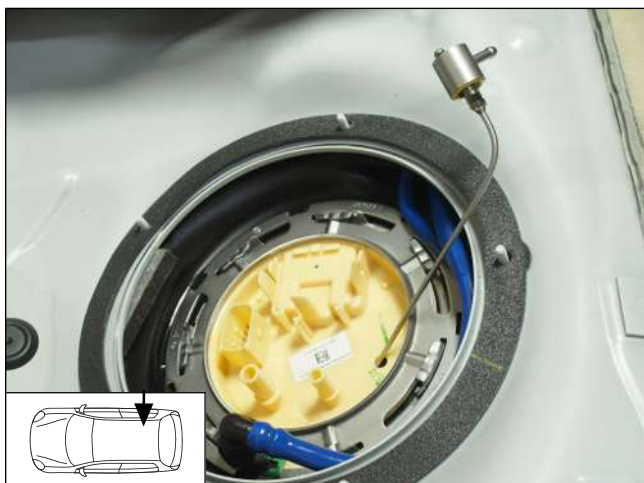

Fig. 65

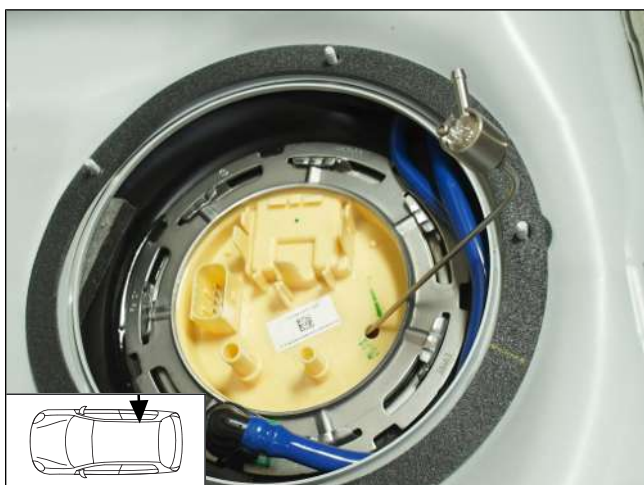

Fig. 66



Fig. 67



Aligning FuelFix



Fig. 68

- ▶ Work steps F5.3, F5.4
- ▶ Align FuelFix as shown.

Connecting fuel line

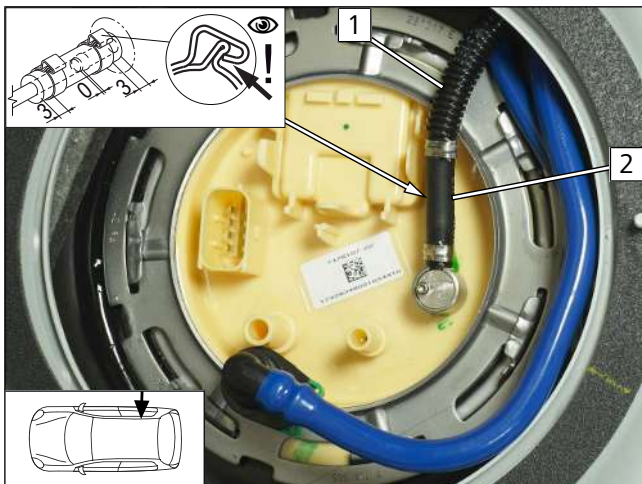

Fig. 69

- ▶ Work step F6.2
- 1 Fuel line in corrugated tube
- 2 Hose section, 10mm dia. clamp [2x]

Mounting FuelFix

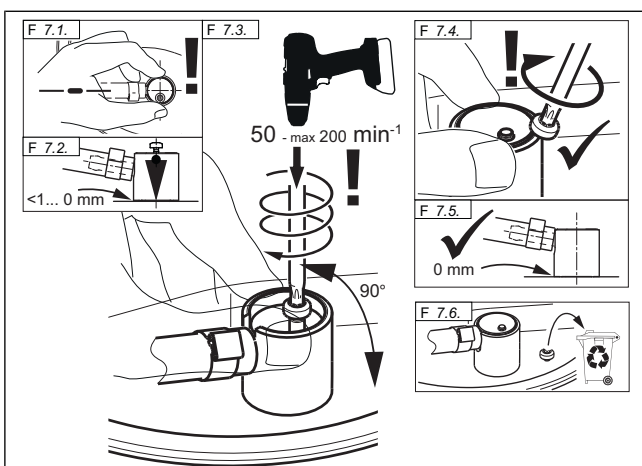

Fig. 70



DANGER

Risk of fire and explosion due to leaking fuel and escaping fuel vapours

- ▶ Work step F7



Checking firm seating of FuelFix



Fig. 71

► Work step F8

Securing fuel line

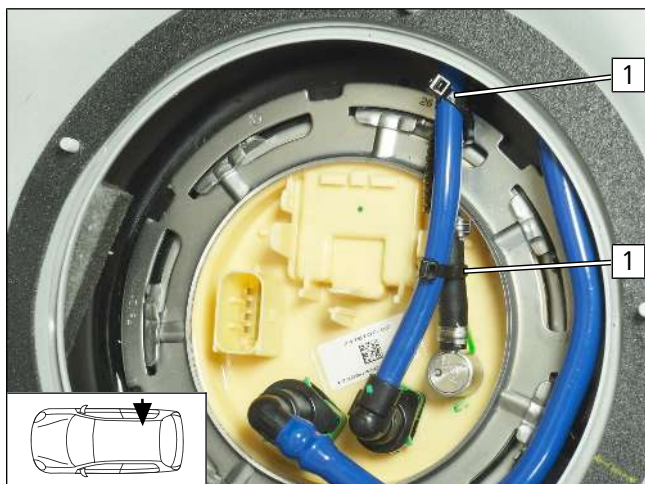

Fig. 72

1 Cable tie for tension relief

9.3 Fuel pump connection

Routing fuel line

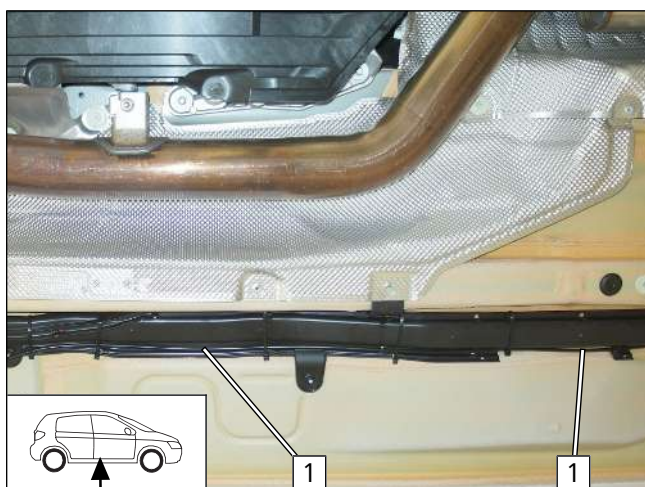
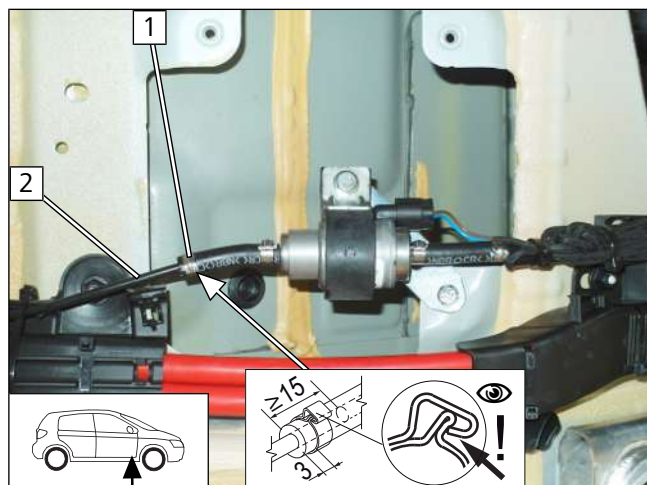

Fig. 73

► Route fuel line FuelFix 1 on original vehicle line to installation location of fuel pump and fasten with cable ties.



Connecting fuel pump



- 1 10mm dia. clamp
- 2 Fuel line FuelFix

Fig. 74



10 Exhaust

Copying hole pattern, drilling hole

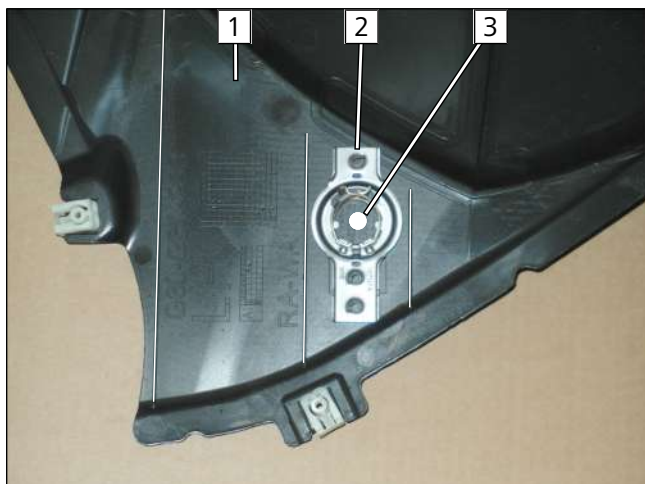

Fig. 75



Observe the EFIX installation instructions.

► Work steps E1.1 and E1.2

- 1 Front wheel well trim on the left
- 2 EFIX
- 3 Hole pattern / hole

Copying hole pattern, drilling hole

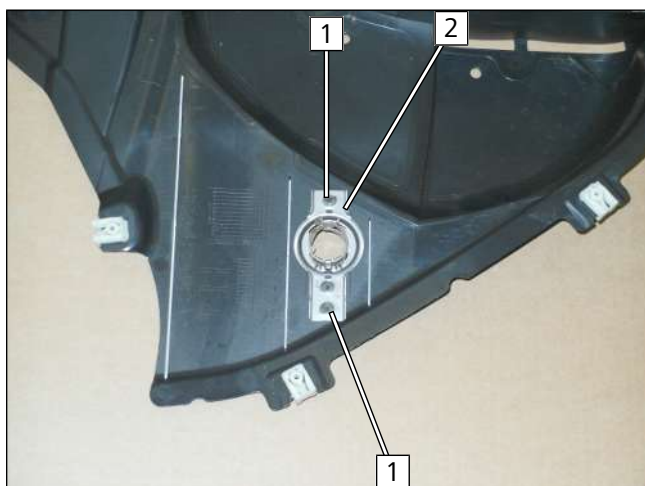

Fig. 76

► Work steps E3 and E4

- 1 Hole pattern / hole
- 2 EFIX

Mounting EFIX

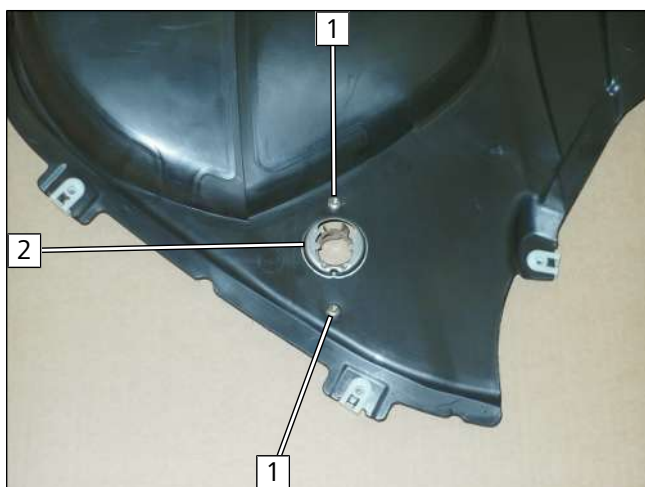

Fig. 77

► Work step E5

- 1 5x13 self-tapping screw
- 2 EFIX



Mounting exhaust pipe **a2**

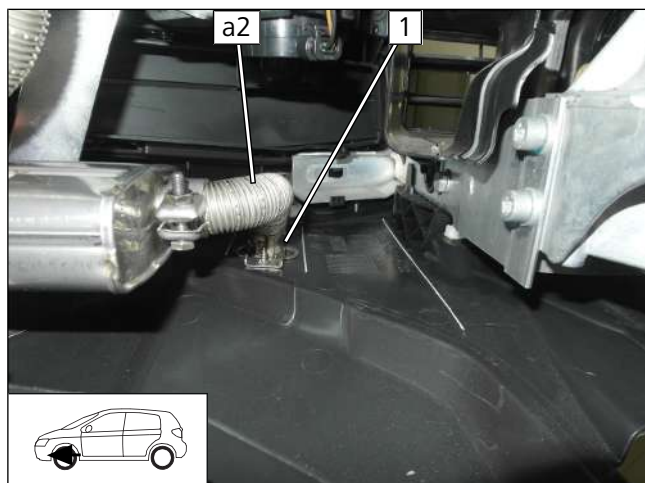

Fig. 78

► Mount front wheel well trim.

1 EFIX

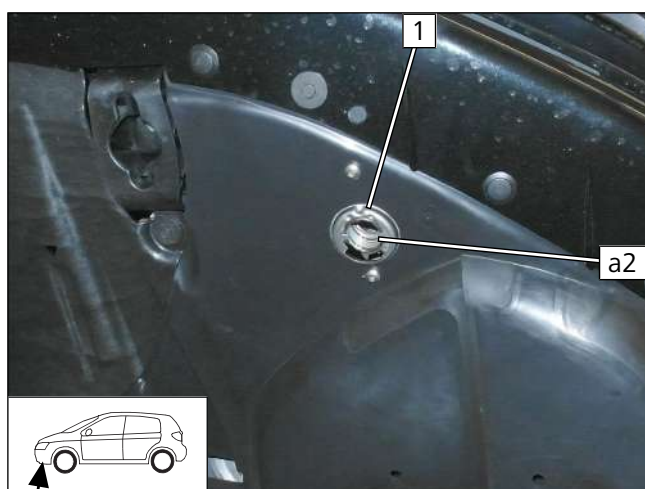

Fig. 79

► Work step E5

1 5x13 self-tapping screw

Checking distance

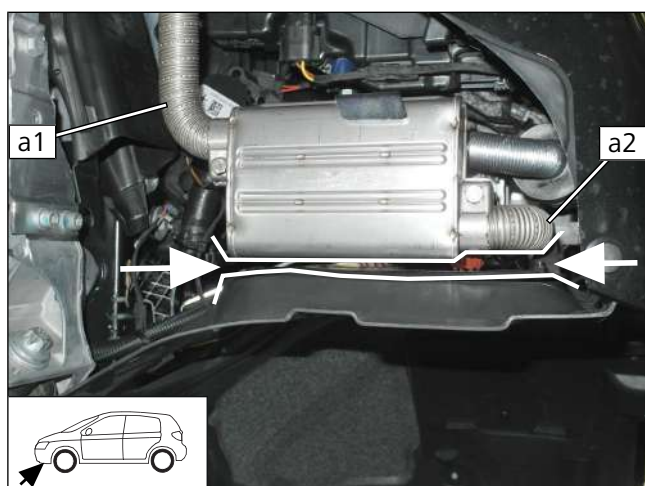

Fig. 80



Ensure sufficient distance from neighbouring components, correct if necessary.





11 Final work in engine compartment

Cutting brake air duct

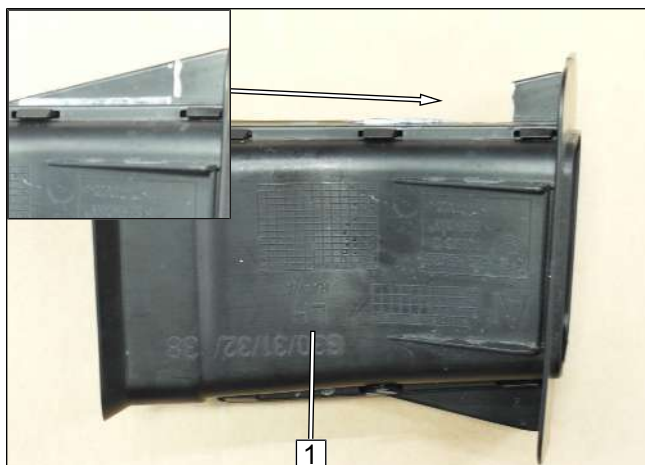

Fig. 81

- ▶ Cut brake air duct **1** as shown.

Gluing foam

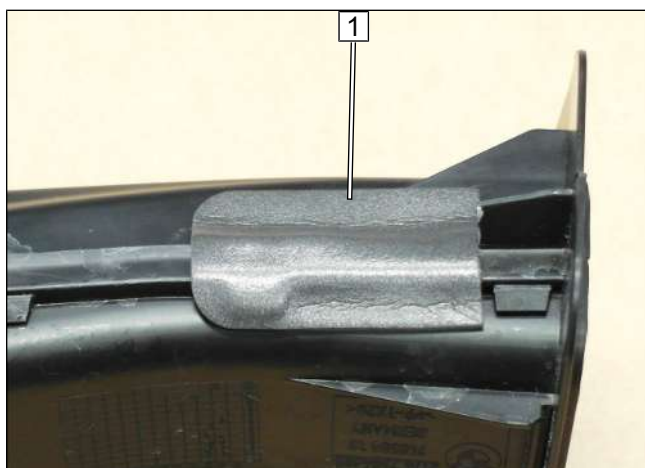

Fig. 82

- ▶ Glue self-adhesive foam **1** as shown on air duct.



12 Electrical system of passenger compartment

12.1 Mounting cold start system

Integrate the cold start system as per the separate installation documentation:



'Cold start for BMW 5 Series 2017 Diesel' installation documentation

12.2 Air-conditioning control

Integrate the air-conditioning control as per the separate installation documentation:



'Webasto Comfort' air-conditioning control installation documentation for AAC of BMW X3 / 5 Series



13 Electrical system of control elements

13.1 MCC option

Mounting MCC



Fig. 83



Observe the MultiControl CAR installation documentation.

- 1 MCC installation frame

13.2 Telestart option



Fig. 84

- 1 Receiver
- 2 M5x16 bolt, large diameter washer, perforated bracket, Telestart bracket, large diameter washer, flanged nut

Mounting receiver

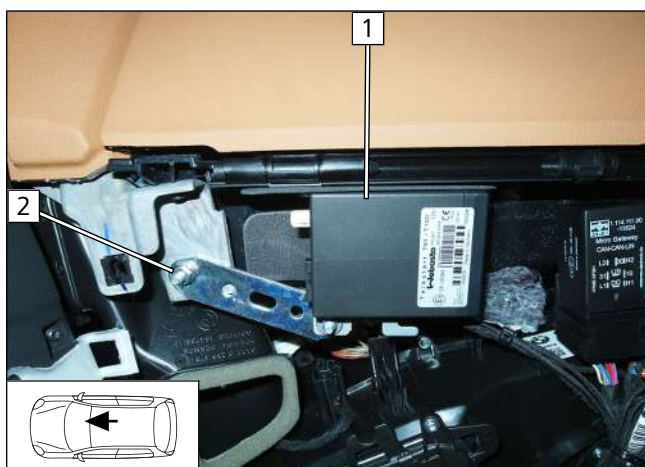

Fig. 85



Observe the Telestart installation documentation.

- 1 Premounted receiver
- 2 Original vehicle stud bolt, perforated bracket, flanged nut



Mounting temperature sensor, only in case of T100 HTM

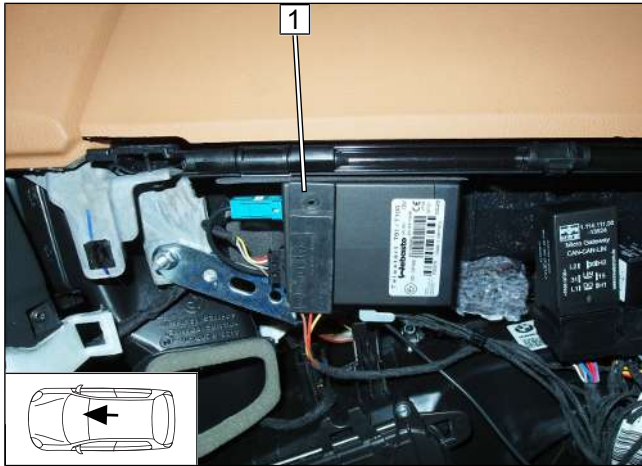

Fig. 86

- Fasten temperature sensor **1** using double-sided adhesive tape.

Mounting aerial

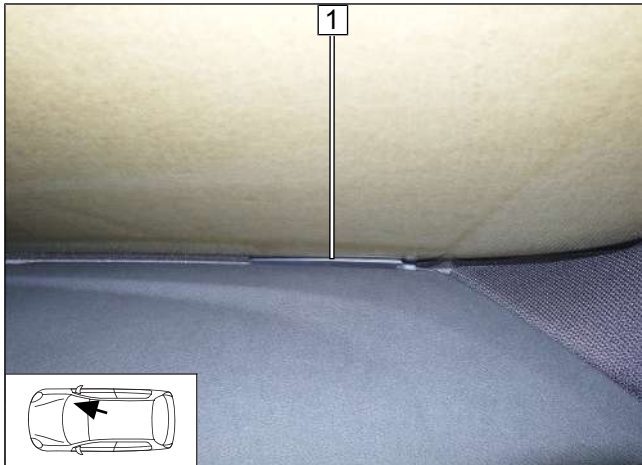

Fig. 87

- 1** Aerial

13.3 ThermoCall option

Preparing receiver

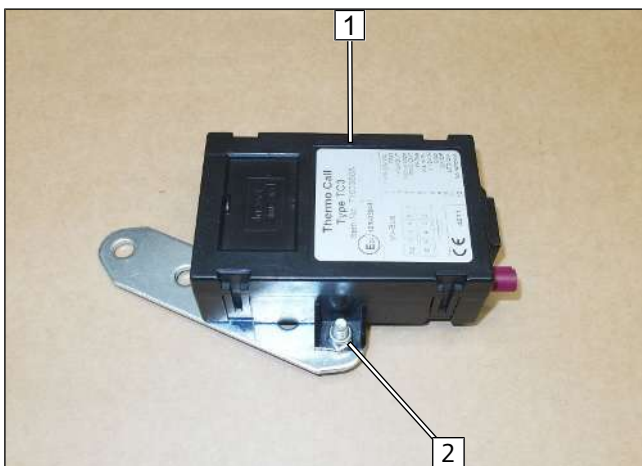

Fig. 88

- 1** Receiver
- 2** M5x16 bolt, large diameter washer, perforated bracket, receiver, nut



Mounting receiver



Fig. 89



Observe the ThermoCall installation documentation.

- 1 Premounted receiver
- 2 Original vehicle stud bolt, perforated bracket, flanged nut

Mounting aerial (optional)

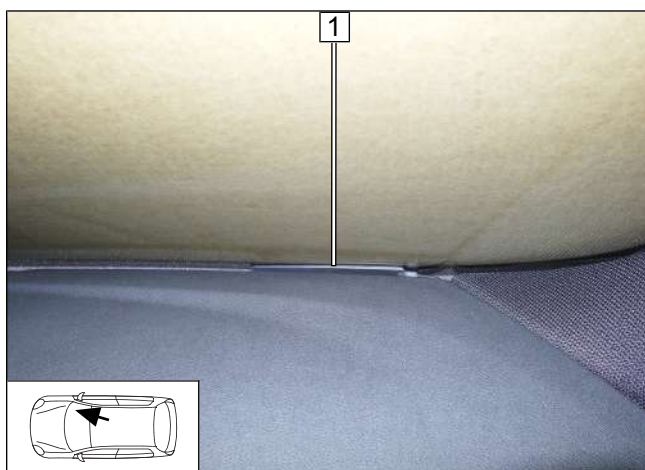

Fig. 90

- 1 Aerial



14 Final Work



Further information can be found in the vehicle manufacturer's technical documentation.

- ▶ Mount removed parts in reverse order.



▶ Check all hoses, clamps and all electrical connections for firm seating.

▶ Insulate and tie back loose lines

▶ Spray heater and electrical components with anti-corrosion wax (Tectyl 100K).

▶ Connect the battery.



Only use manufacturer-approved coolant.

- ▶ Fill and bleed the coolant circuit according to the vehicle manufacturer's specifications.



Further information can be found in the general installation and operating instructions of the Webasto components.

▶ Program MultiControl CAR, teach Telestart transmitter

▶ If the fan function or A/C control panel settings need to be checked, see the installation documentation in the additional kit 'Webasto Comfort' A/C control, section 'Final work'

▶ Initial start-up and function check

▶ Affix 'Switch off parking heater before refueling' caution label in area of filler neck

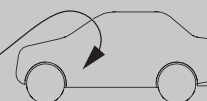
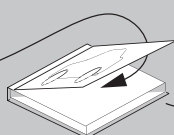
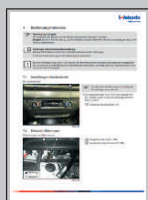
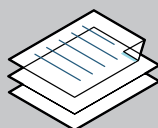

These are the original instructions. The German language is binding.
You can request your language if it is missing. The telephone number of each country can be found in the Webasto service centre leaflet or the website of the respective Webasto representative of your country.

Webasto Thermo & Comfort SE
Postfach 1410
82199 Gilching
Germany

Company address:
Friedrichshafener Str. 9
82205 Gilching
Germany

Technical Extranet: <https://dealers.webasto.com>

Only within Germany
Tel: 0395 5592 444
E-mail: technikcenter@webasto.com



WWW.WEBASTO.COM



15 FuelFix template

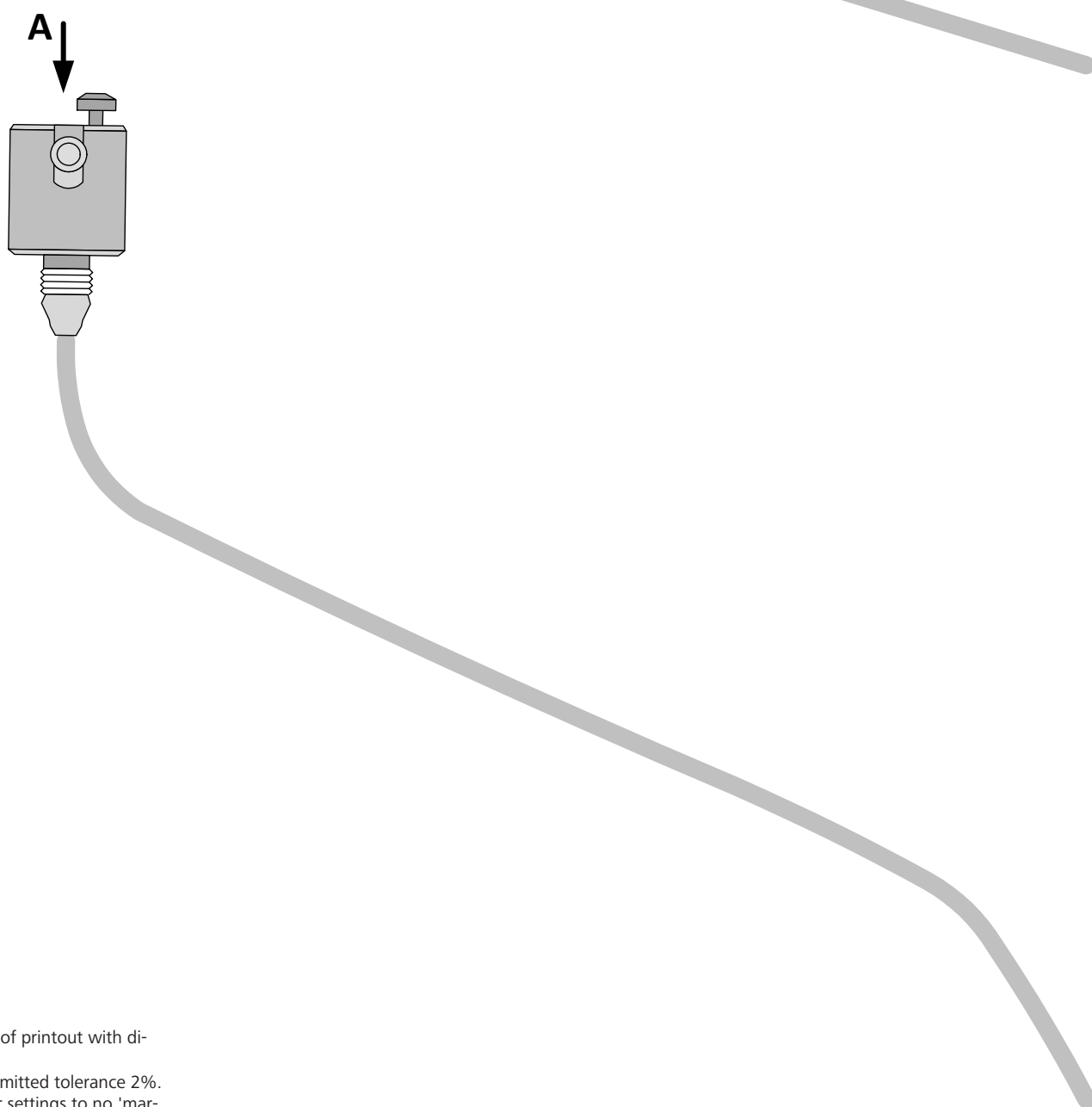
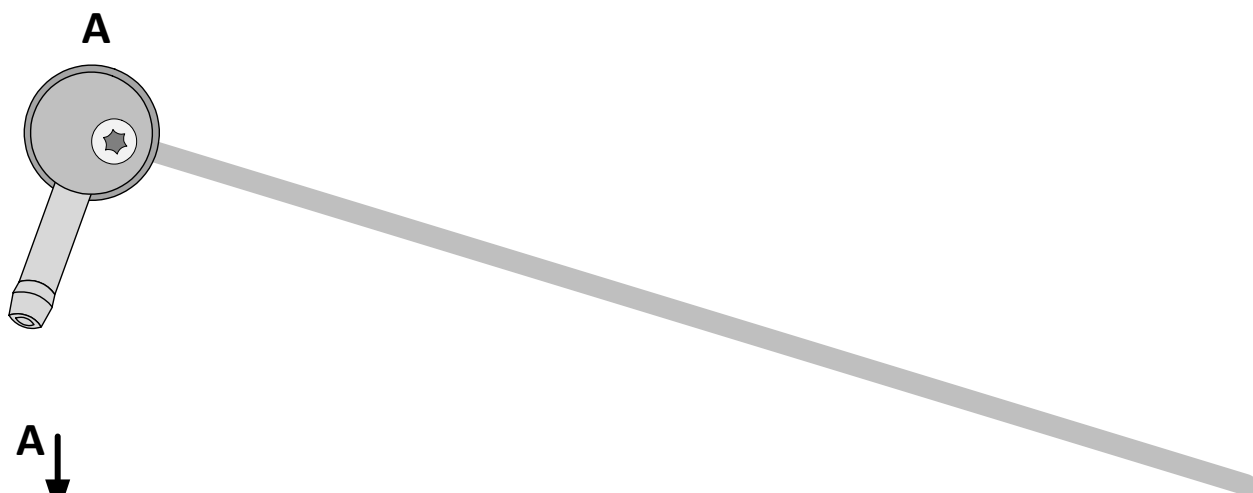

100mm

0

100mm

Scale 1:1
Compare size of printout with dimension lines.
Maximum permitted tolerance 2%.
Set the printer settings to no 'margin' or 'minimise margins' and 100% of the normal size.

