

K Installation documentation

for Thermo Top Evo water heater

'Island' coolant circuit without engine preheating

Hyundai Tucson / Kia Sportage

Left-hand drive vehicle

Manufacturer	Model	Type	Model year	EG-BE-No. / ABE
Hyundai	Tucson	TLE	from 2019	e11* 2007/46* 2724*...

Motorisation	Fuel	Emission standard	Transmission type	Output [kW]	Displacement [cm ³]	Engine code
1.6 T-GDI	Petrol	Euro 6d temp	SG	130	1591	G4FJ
1.6 T-GDI	Petrol	Euro 6d temp	AG	130	1591	G4FJ
1.6 GDI	Petrol	Euro 6d temp	SG	97	1591	G4FD

Manufacturer	Model	Type	Model year	EG-BE-No. / ABE
Kia	Sportage	QLE	from 2019	e11* 2007/46* 3144*...

Motorisation	Fuel	Emission standard	Transmission type	Output [kW]	Displacement [cm ³]	Engine code
1.6 T-GDI	Petrol	Euro 6d temp	SG	130	1591	G4FJ
1.6 T-GDI	Petrol	Euro 6d temp	AG	130	1591	G4FJ
1.6 GDI	Petrol	Euro 6d temp	SG	97	1591	G4FD

Validity	Equipment variants	Model	
		Tucson	Sportage
Verified equipment variants	Automatic air-conditioning	x	x
	Halogen main headlights	x	x
	Halogen front fog lights	x	x
	LED daytime running lights	x	x
	LED main headlights	x	x
	Automatic Start-Stop system	x	x
	Keyless Go	x	x
	Start button	x	x
Unverified equipment variants	2 WD / 4 WD	x	x
	Manual air-conditioning	x	x
	Full LED with headlight washer system	x	x
	GT Line		x

Total installation time	Note
8.6 hours	

Contents

1	List of abbreviations	4	15	Electrical system of passenger compartment	61
2	Installation notes	5	15.1	Electrical system preparation	61
2.1	Information on Validity	5	15.2	A/C control panel dismantling instructions for Hyundai Tucson	62
2.2	Components used	5	15.3	A/C control panel dismantling instructions for Kia Sportage	63
2.3	Information on Total Installation Time	5	15.4	Wiring diagram	65
2.4	Installation Recommendations	5	15.5	Fan controller	67
3	About this document	6	16	Electrical system of control elements	69
3.1	Purpose of the document	6	16.1	MultiControl CAR option	69
3.2	Warranty and liability	6	16.2	Telestart option	69
3.3	Safety	6	16.3	ThermoCall option	70
3.4	Using this document	7	17	Final Work	72
4	Technical Information	8	18	FuelFix template	75
5	Preparing measures	9	19	Operating instructions for automatic air-conditioning of Hyundai Tucson	77
5.1	Vehicle preparation	9	19.1	A/C control panel settings	77
5.2	Heater preparation	9	19.2	Installation location of fuses	77
6	Installation overview	10	20	Operating instructions for automatic air-conditioning of Kia Sportage	79
7	Electrical system of engine compartment	11	20.1	A/C control panel settings	79
8	Mechanical system	13	20.2	Installation location of fuses	79
8.1	Preparing installation location	13			
8.2	Premounting heater	16			
8.3	Heater mounting	18			
9	Fuel	20			
9.1	Routing fuel line	20			
9.2	Installing FuelFix	25			
10	Combustion air	30			
11	Coolant for 97kW	31			
11.1	Hose routing diagram	31			
11.2	Coolant circuit installation	32			
12	Coolant for 130kW	43			
12.1	Hose routing diagram	43			
12.2	Coolant circuit installation	44			
13	Exhaust	55			
13.1	Mounting exhaust pipe	55			
13.2	Mounting exhaust end fastener	57			
14	Final work in engine compartment	60			

1 List of abbreviations

AG	Automatic transmission
DP	Fuel pump
EFIX	Exhaust end fastener
FF	FuelFix (tank extracting device)
Fig.	Figure
HG	Heater
MCC	MultiControl (control element)
RSH	Relay and fuse holder of passenger compartment
SG	Manual transmission
SH2	Engine compartment fuse holder for F1/F2
UP	Coolant pump

2 Installation notes

2.1 Information on Validity

This installation documentation applies to vehicles listed on page 1, assuming technical modifications to the vehicle do not affect installation, any liability claims excluded. Depending on the vehicle version and equipment, modifications may be necessary during installation with respect to this installation documentation. Vehicle and engine types, equipment variants and other specifications not listed in this installation documentation have not been tested. However, installation according to this installation documentation may be possible.

2.2 Components used

Designation	Order number
Basic delivery scope of Thermo Top Evo (see installation recommendation)	In accordance with price list
Installation kit for Hyundai Tucson/Kia Sportage diesel and petrol island MY 2019 TT-Evo	1327062A
In case of MultiControl CAR installation – installation frame for MultiControl	9030077_
In case of control element as well as Telestart indicator lamp in consultation with end customer	In accordance with price list

2.3 Information on Total Installation Time

The total installation time includes the time needed for mounting and demounting the vehicle-specific components, the heater specific installation time and all other times required for the system integration and initial start-up of the heater.

The total installation time may vary for vehicle equipment other than provided.

2.4 Installation Recommendations

Arrange for the vehicle to be delivered with the tank only about ¼ full.

For the MultiControl CAR option, the recommended installation locations for the Telestart or ThermoCall push button should be confirmed with the end customer.

Depending on the space required and the vehicle manufacturer's instructions, we recommend the use of a vehicle battery with a higher electrical capacity.

We recommend installing a Thermo Top Evo 4. The heater is integrated into the coolant circuit as an 'island' and heats up the vehicle passenger compartment. There is no engine pre-heating.

3 About this document

3.1 Purpose of the document

This installation documentation is part of the product and contains all the information required to ensure professional vehicle specific installation of the:

Thermo Top Evo heater

3.2 Warranty and liability

Webasto shall assume no liability for defects, damage and injuries resulting from a failure to observe the installation, repair and operating instructions of the information contained in them.

This liability exclusion particularly applies to improper installations and repairs by untrained persons or in the case of a failure to use genuine spare parts.

The liability due to culpable disregard to life, limb or health and due to damage or injuries caused by a wilful or reckless breach of duty remain unaffected, as does the obligatory product liability.

Installation should be carried out according to the general, standard rules of technology. Unless specified otherwise, fasten hoses, lines and wiring harnesses to original vehicle lines and wiring harnesses using cable ties. Insulate loose wire ends and tie back. Connectors on electronic components must audibly snap into place during assembly.

Spray unfinished body areas, e.g. drilled holes, with anti-corrosion wax (Tectyl 100K).

Observe the instructions and guidelines of the respective vehicle manufacturer for demounting and mounting vehicle specific components.

The initial start-up is to be executed with the Webasto Thermo Test Diagnosis.

When installing a programmable control module (e.g. a PWM Gateway), the corresponding settings must be checked or adjusted.

3.2.1 Statutory regulations governing installation

The Thermo Top Evo heater has been type-tested and approved in accordance with ECE-R 10 (EMC) and ECE-R 122 (heater). The regulations of these guidelines are binding in the scope of the Directive 70/156/EEC and/or 2007/46/EC (for new vehicle models from 29/04/2009) and should also be observed in countries in which there are no special regulations.

The heater is licensed in accordance with paragraph 19, section 3, No. 2b of the StVZO (German Road Traffic Licensing Authority).

3.3 Safety

Qualifications of installation personnel

The installation personnel must have the following qualifications:

- Successful completion of Webasto training
- Corresponding qualification for working on technical systems

Regulations and legal requirements

The regulations from the heater's general installation and operating instructions must be observed.

3.3.1 Safety information on installation

Danger posed by live parts

- ▶ Prior to installation, disconnect the vehicle from the voltage supply.
- ▶ Make sure the electrical system is earthed correctly.
- ▶ Always comply with legal requirements.
- ▶ Observe data on type label.

Danger of fire and leaking toxic gases due to improper installation

- ▶ Vehicle parts in the vicinity of the heater must be protected against excessive heating by the following measures:
 - ⇒ Maintain minimum safety distances.
 - ⇒ Ensure adequate ventilation.
 - ⇒ Use fire-resistant materials or heat shields.

Danger due to sharp edges









- Lacerations
- Short circuit due to electrical wire damage
- ▶ Fit protectors on sharp edges.

3.4 Using this document

Before installing and operating the heater, read this installation documentation, the installation instructions of the heater, the operating instructions and supplementary sheets provided.

3.4.1 Explanatory Notes on the Document

There is an identification mark near the respective work step to allow you to quickly allocate the other applicable documents to the Webasto components to be installed:

Generally valid Webasto documentation	
Vehicle-specific installation documentation	
Vehicle-specific installation documentation of the cold start kit	
Webasto Comfort A/C control	
Webasto Standard A/C control	
Tank extracting device (e.g. FuelFix)	
Exhaust end fastener (EFIX)	
Combustion air intake silencer	
Spacer bracket (ASH)	

3.4.2 Use of symbols



DANGER

Type and source of the risk

Consequences: Failure to follow the instructions can result in death

► Actions to protect yourself against risks.



WARNING

Type and source of the risk

Consequences: Failure to follow the instructions can lead to serious or even fatal injuries

► Actions to protect yourself against risks.



CAUTION

Type and source of the risk

Consequences: Failure to follow the instructions can lead to minor injuries

► Actions to protect yourself against risks.



Type and source of the risk

Consequences: Failure to follow the instructions can lead to material damage

► Actions to protect yourself against risks.











Reference to the vehicle manufacturer's specific documents.

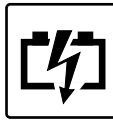

Note on a special technical feature

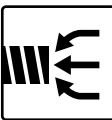
3.4.3 Work step identification marks

The ongoing work step is indicated on the outside top corner of the page:

Mechanical system	Electrical system	High-voltage	Coolant
			
Combustion air	Fuel	Exhaust	Software
			

3.4.4 Orientation aid

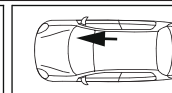

The arrow indicates the position on the vehicle and the viewing angle

3.4.5 Use of highlighting

Highlight	Explanation
►	Necessary action
⇒	Result of an action
1 / 12 / a1	Position numbers for the image descriptions
① / ⑫ / Ⓐ	Position numbers for the image descriptions for electrical wires and coolant hose sections

4 Technical Information

Dimension specifications

- All dimensions specified in mm
- Perforated brackets and mounting angles are shown to scale
- Observe data regarding scale on the templates

Tightening torque specifications

- Tightening torque values of 5x13 heater bolts and 5x11 heater stud bolts = 8Nm
- Tightening torque values of 5x15 retaining plate of water connection piece bolts = 7Nm
- 5x12 bolt tightening torque of 2-part heater bracket = 6Nm
- Tighten other bolt connections in accordance with manufacturer's instructions or in accordance with state-of-the-art-technology

Temperature specification for heat shrink plastic tubings

- Fabric heat shrink tubing: shrink temperature max. 230°C
- Standard heat shrink plastic tubing: shrink temperature max. 300°C

Necessary special tools

- Hose clamp pliers for auto-tightening hose clamps
- Hose clamp pliers for Clic hose clamps of type W
- Hose clamping pliers
- Hose cutter
- Automatic wire stripper 0.2 - 6 mm²
- Crimping pliers for cable lugs 0.5 – 10 mm²
- Crimping pliers for male connector 0.14 – 6 mm²
- Crimping pliers for connector 0.25 – 6 mm²
- Torque wrench for 2.0 - 10 Nm
- Deep-hole marker
- Metric thread-setter kit
- Webasto Thermo Test Diagnosis with current software

5 Preparing measures

5.1 Vehicle preparation



Further information can be found in the vehicle manufacturer's technical documentation.

Vehicle area	Components to be removed	Other applicable documents
General	<ul style="list-style-type: none"> ▶ Open the fuel tank cap ▶ Ventilate the fuel tank ▶ Close the fuel tank cap again ▶ Depressurise the cooling system 	
Engine compartment and body	<ul style="list-style-type: none"> ▶ Front wheel on the driver's side ▶ Front wheel well trim on the driver's side ▶ Lower engine trim ▶ Underbody trim on the driver's side ▶ Drain the engine coolant ▶ Plenum ▶ Battery ▶ Engine control unit (T-GDI only) ▶ Entire air filter housing ▶ Intake hose (T-GDI only) ▶ Battery carrier 	
Passenger compartment	<ul style="list-style-type: none"> ▶ Upper front footwell trim on the front passenger's side ▶ Front entrance strip trim on the front passenger's side ▶ Lower A-pillar trim on the front passenger's side ▶ Centre console trim in the footwell on the front passenger's side ▶ Side instrument panel trim on the driver's and front passenger's side (Kia Sportage only) ▶ Lower instrument panel trim on the driver's side (Kia Sportage only) ▶ Glove box (Kia Sportage only) ▶ Instrument panel trim piece (Kia Sportage only) ▶ A/C control panel (see dismantling instructions) ▶ Rear bench seat (pay attention to the seat heating connectors) ▶ Open the tank fitting service lid 	

5.2 Heater preparation

Engine compartment	<ul style="list-style-type: none"> ▶ Remove years that do not apply from the type and duplicate label ▶ Attach the duplicate label (type label) in the appropriate place in the engine compartment 	
--------------------	--	--

6 Installation overview

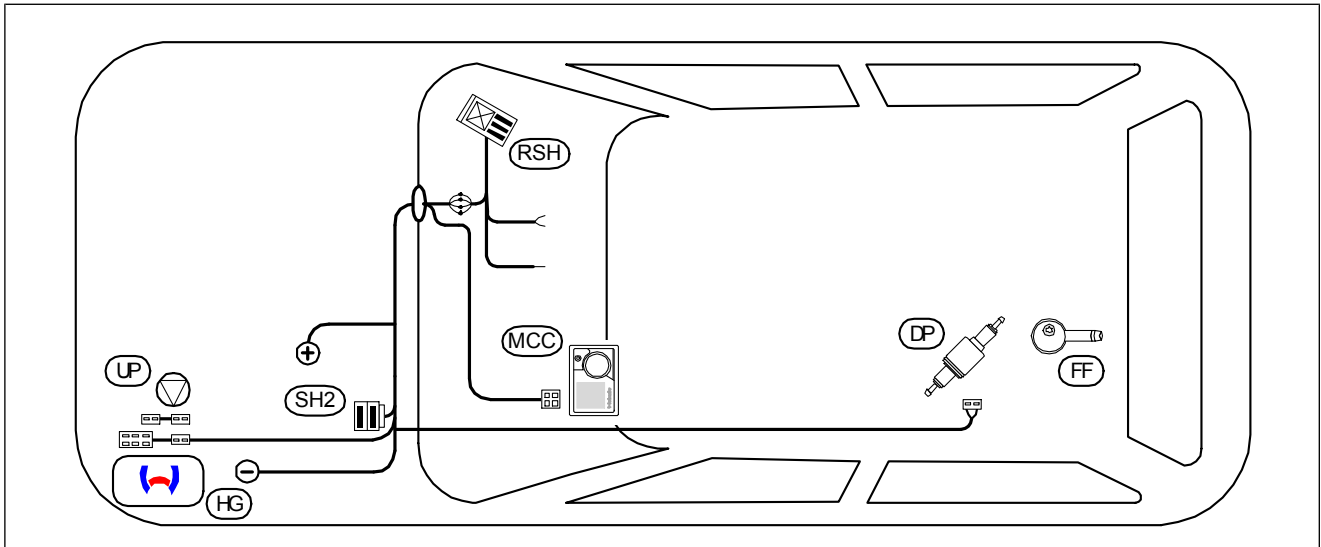
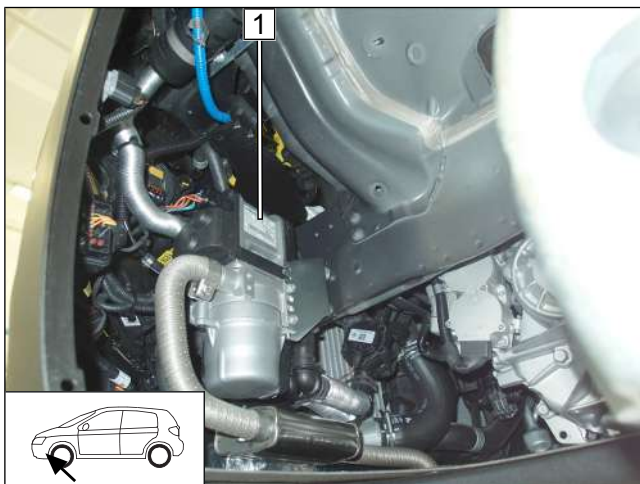

Fig. 1

Legend to installation overview

Abbreviation	Component
DP	Fuel pump
FF	FuelFix
HG	Heater
MCC	MultiControl CAR
RSH	Relay and fuse holder of passenger compartment
SH2	Engine compartment fuse holder for F1/F2
UP	Coolant pump

Heater installation location



1 Heater

Fig. 2



7 Electrical system of engine compartment

Preparing fuse holder of engine compartment



Fig. 3

- 1 M5x16 bolt, large diameter washer, retaining plate of SH2, angle bracket, large diameter washer, nut

Mounting retaining plate of SH2

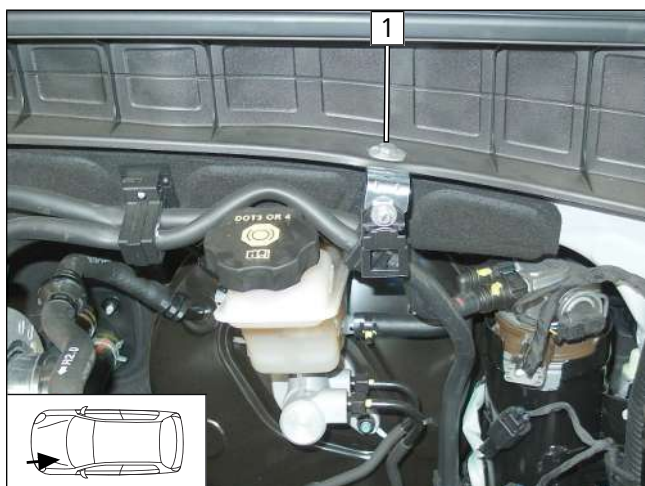

Fig. 4

► Remove clip at pos. 1.

- 1 M6x20 bolt, large diameter washer, original vehicle hole, premounted angle bracket, large diameter washer, flanged nut

Installing SH2



Fig. 5

- 1 Fuses F1 / F2



Earth wire connection

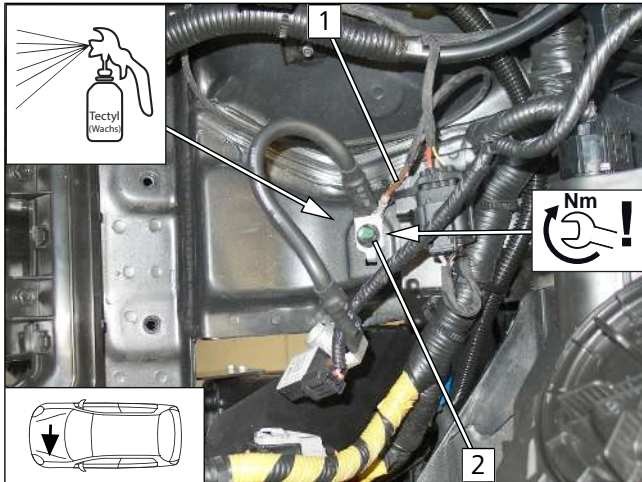

Fig. 6



DANGER

Fire hazard due to insufficient tightening torque

► Observe tightening torque

- 1 Earth wire
- 2 Original vehicle earth point

Positive wire connection

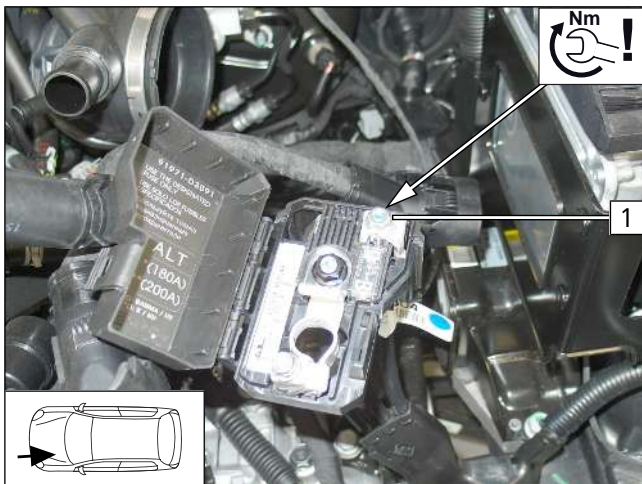

Fig. 7



DANGER

Fire hazard due to insufficient tightening torque

► Observe tightening torque

- 1 Positive wire on positive distributor

Passenger compartment wiring harness pass through

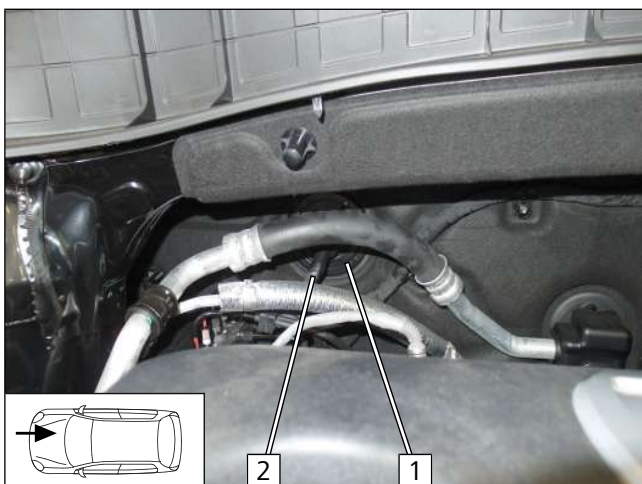

Fig. 8

- 1 Protective rubber plug
- 2 Passenger compartment and control element wiring harnesses



8 Mechanical system

8.1 Preparing installation location

Detaching original vehicle earth points

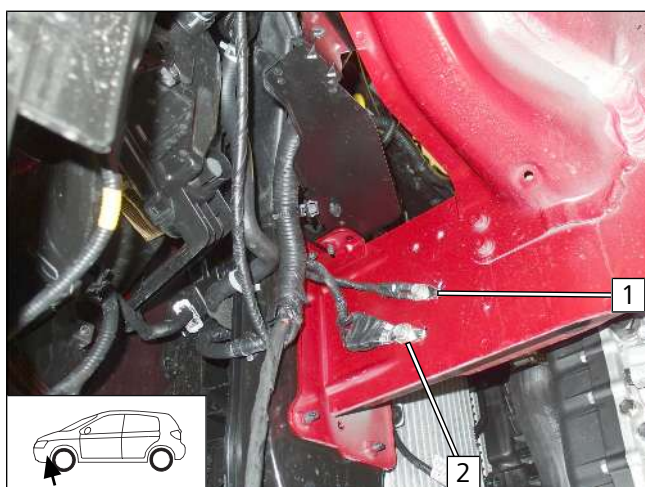

Fig. 9

- 1 Original vehicle earth point **a**
- 2 Original vehicle earth point **b**

Inserting rivet nut

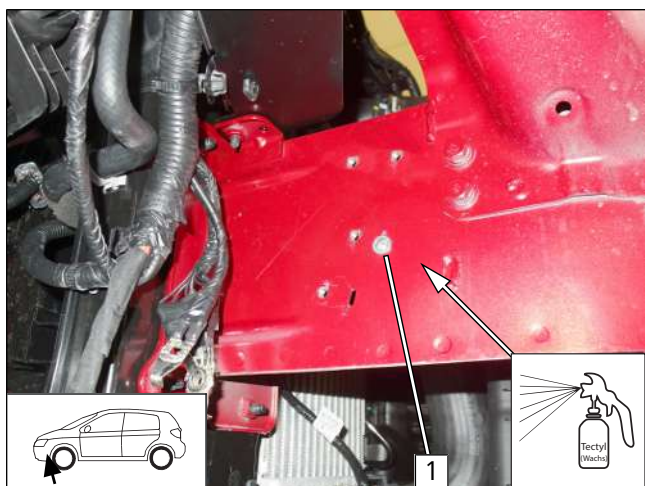

Fig. 10

- 1 Drill out oblong hole to Ø9, insert rivet nut

Copying hole pattern

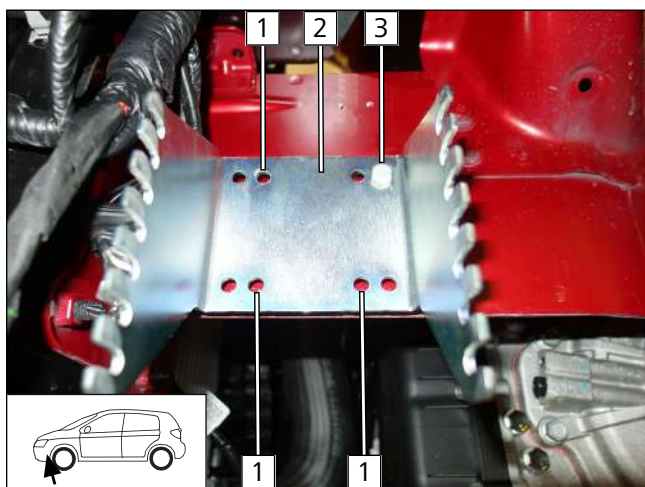

Fig. 11

- Mount bracket **2** loosely and align as shown in Fig..
 - 1 Copy hole pattern
 - 2 M6x30 bolt
- Remove bracket.



Drilling holes and inserting rivet nut

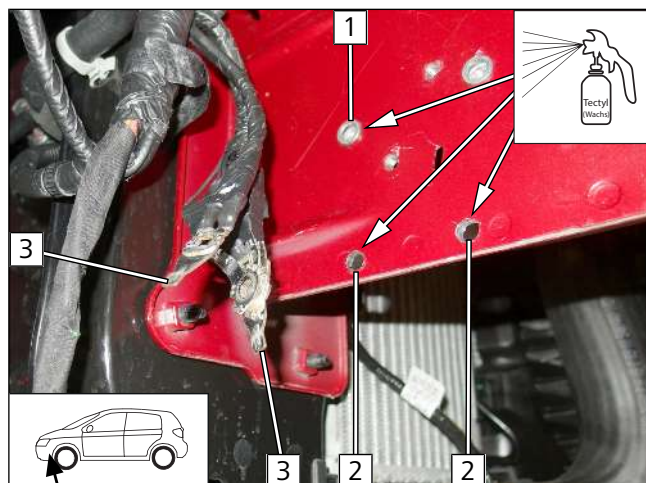

Fig. 12

► Straighten earth point **3**.

- 1** Ø9 hole, rivet nut
- 2** Ø7 hole

Mounting earth point

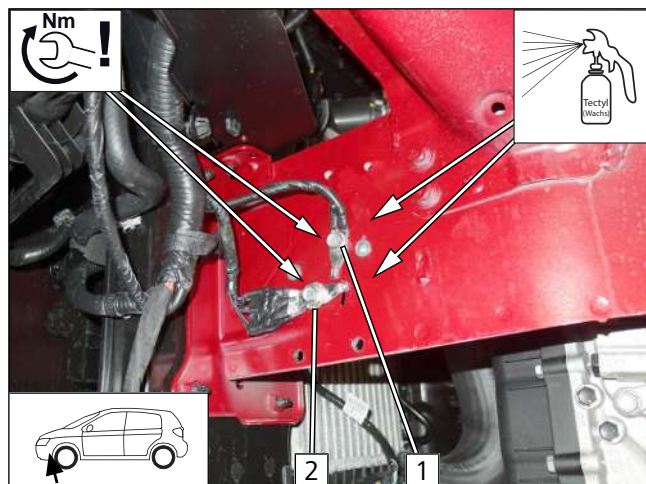

Fig. 13

- 1** Original vehicle bolt, earth point **a**
- 2** Original vehicle bolt, earth point **b**

Mounting bracket

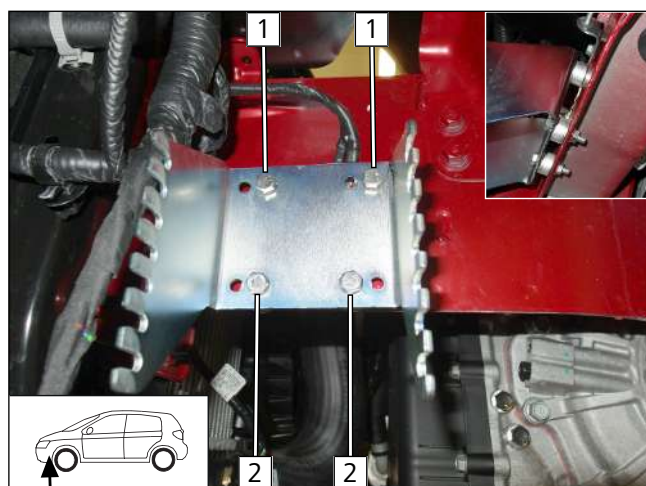

Fig. 14

- 1** M6x30 bolt, spring lock washer, bracket, distance washer (8), rivet nut
- 2** M6x30 bolt, bracket, distance washer (8), drilled hole, M6 nut



Inserting rivet nut for air intake silencer

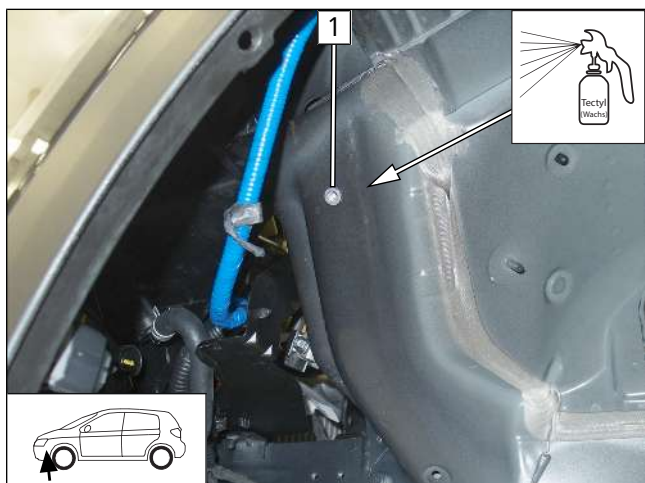

Fig. 15

- 1 Rivet nut in original vehicle hole

Removing original vehicle earth strap with retaining clip from hole

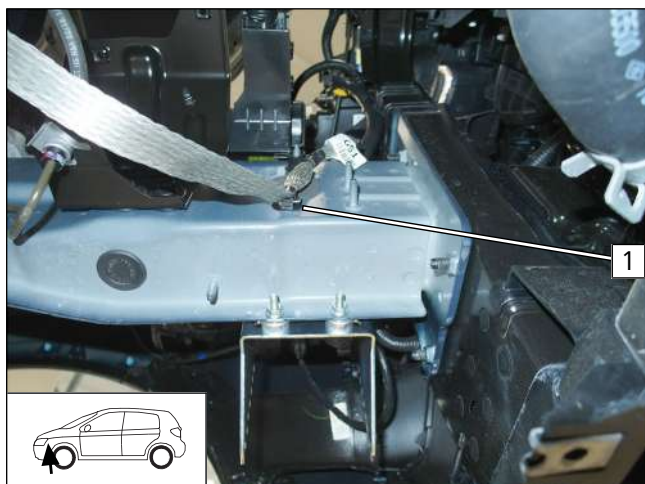

Fig. 16

- 1 Original vehicle earth strap, retaining clip

Inserting rivet nut for coolant pump

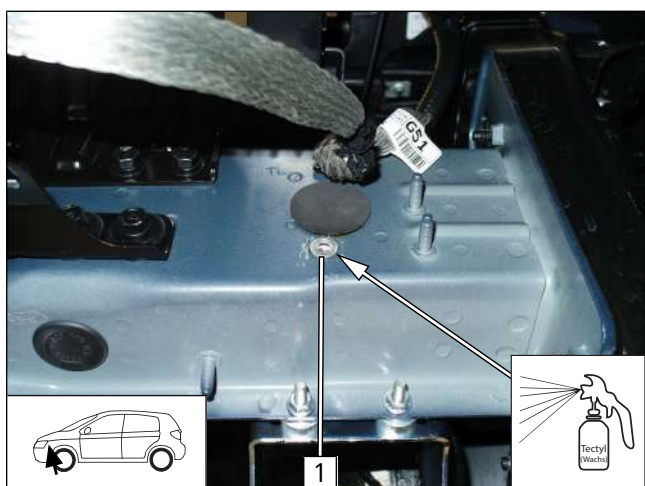

Fig. 17

- Drill out original vehicle hole to Ø9.

- 1 Rivet nut in original vehicle hole



Hole for exhaust silencer

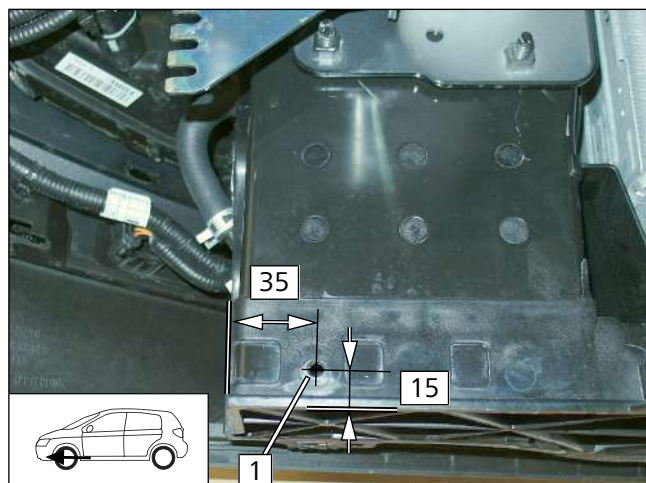

Fig. 18

1 Ø7 hole

Fixing original vehicle wiring harnesses, if available

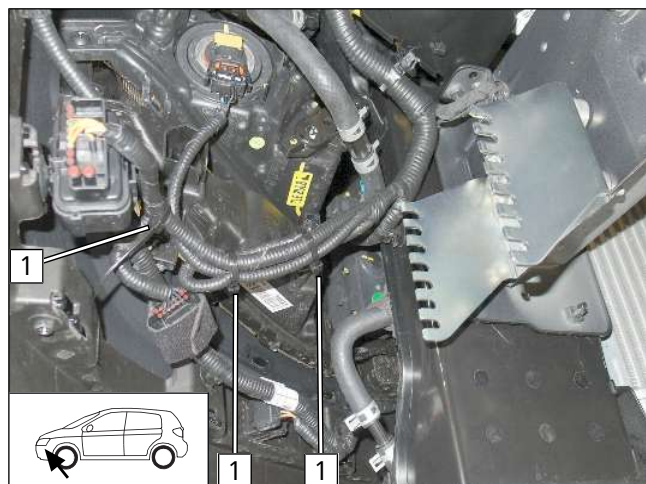

Fig. 19

1 Cable tie

8.2 Premounting heater

Premounting bolts loosely

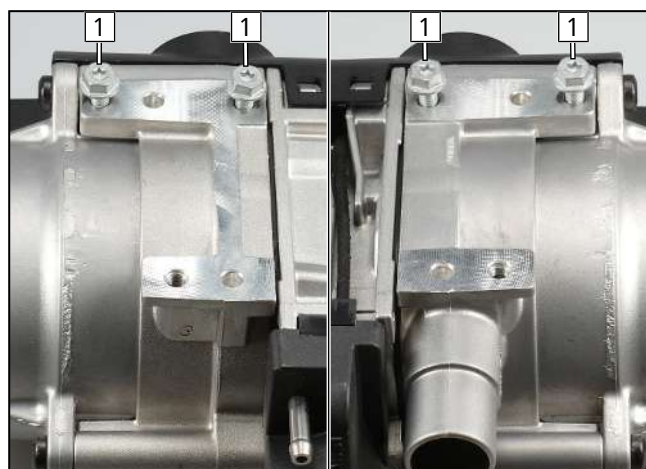

Fig. 20

► Screw 5x13 self-tapping bolts **1** into existing holes by a maximum of 3 thread turns.



Mounting water connection piece

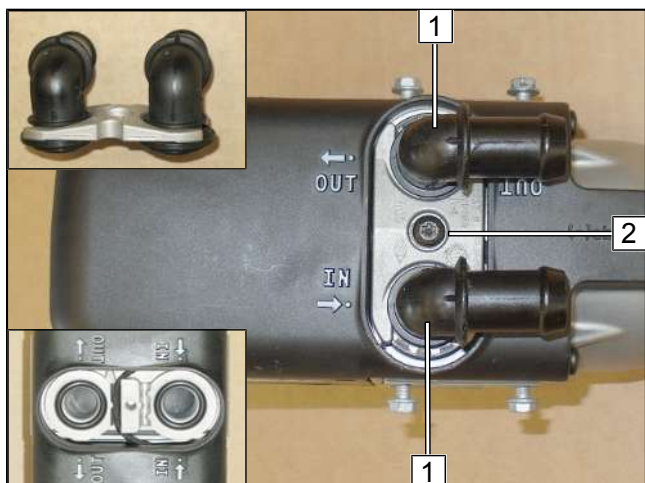

Fig. 21



Observe the general installation instructions of the heater.

- 1 90° water connection piece, seal
- 2 5x15 self-tapping bolt, water connection piece retaining plate

Cutting combustion air pipe to length

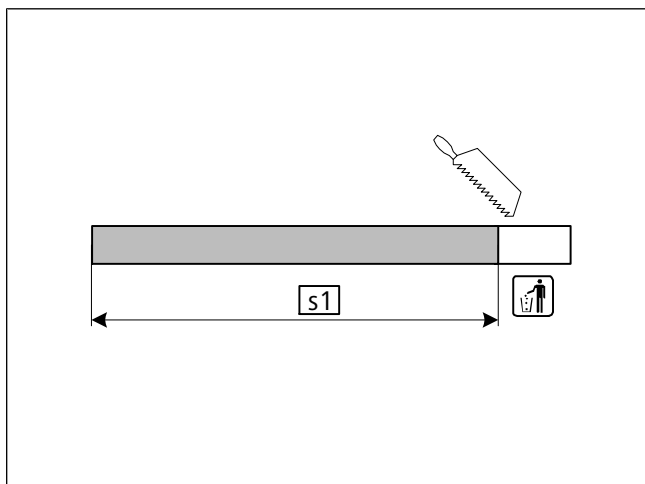

Fig. 22

s1 330

Mounting combustion air intake pipe and fuel line

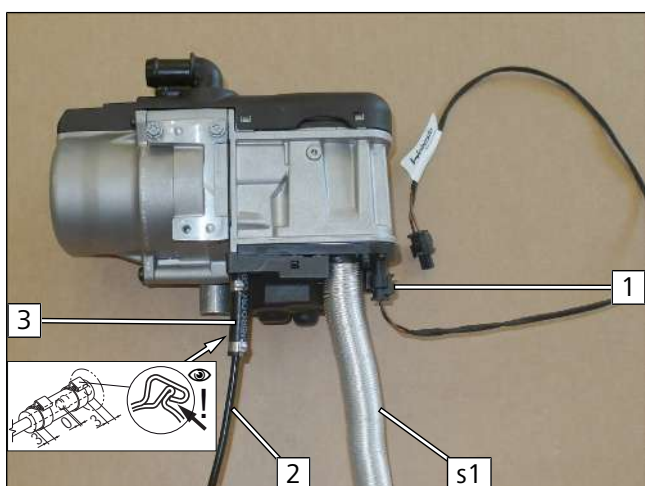

Fig. 23



Observe the general installation instructions of the heater.

- 1 Coolant pump wiring harness connector
- 2 Fuel line
- 3 Hose section, Ø10 clamp [2x]



Cutting hoses to length

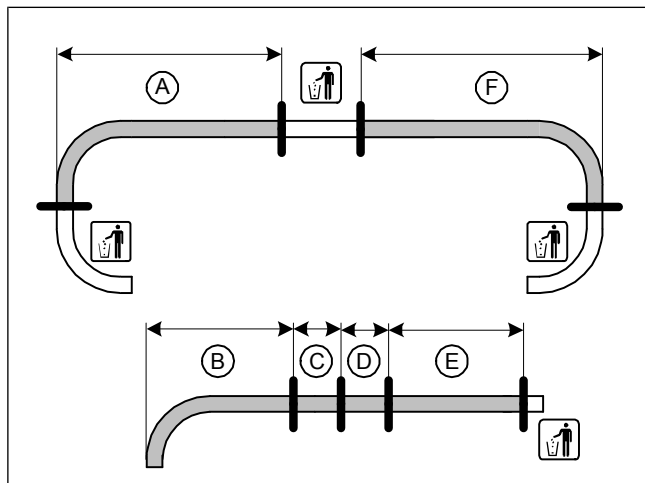

Fig. 24

	1.6 GDI	1.6 T-GDI SG	1.6 T-GDI AG
A	890	910	870
B	185	185	185
C	60	60	60
D	60	60	60
E	170	170	170
F	920	970	930

Premounting hoses

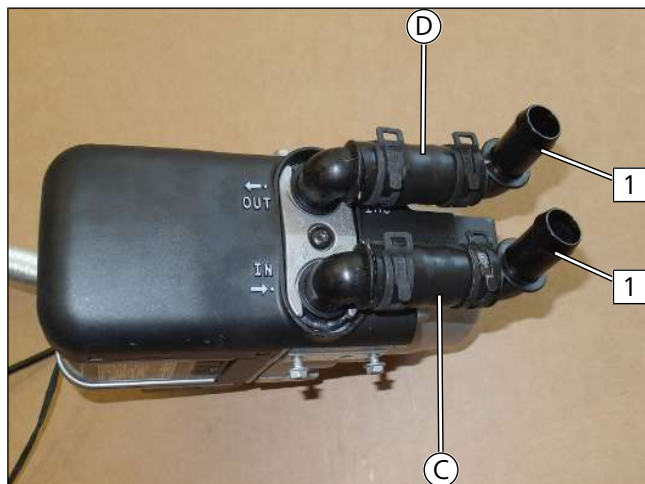

Fig. 25

All spring clips $\varnothing 25$

- 1** $\varnothing 18 \times 18$ 90° connecting pipe

8.3 Heater mounting

Mounting heater

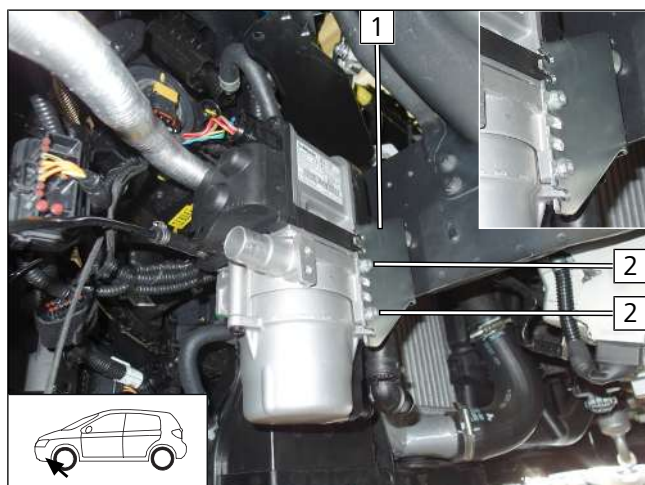
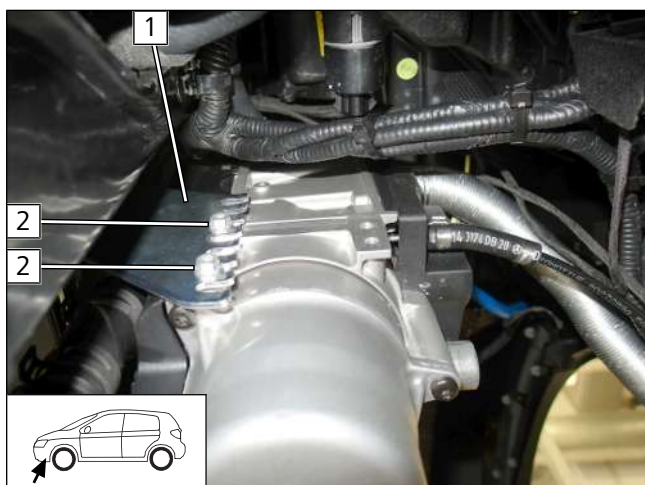

Fig. 26

- 1** Bracket
- 2** 5x13 self-tapping bolt



- 1 Bracket
- 2 5x13 self-tapping bolt

Fig. 27

Mounting HG wiring harness connector

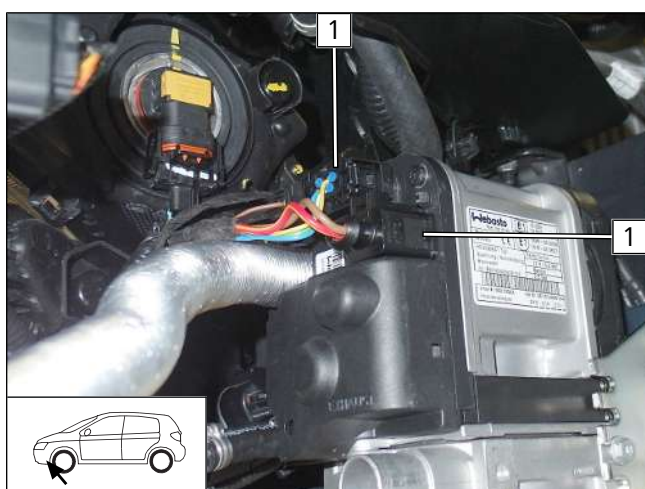

- 1 Heater wiring harness connector

Fig. 28



9 Fuel



DANGER

Risk of fire and explosion due to leaking fuel and escaping fuel vapours.

The incorrect installation of the fuel extractor can cause damage and fire.

- ▶ Avoid electrostatic discharges and open fire
- ▶ When working on the fuel system, ensure sufficient ventilation and bleeding
- ▶ Open the fuel tank cap of the vehicle
- ▶ Ventilate the fuel tank
- ▶ Re-close the tank lock
- ▶ Catch any fuel running off with an appropriate container



Danger of damage to components

- ▶ Install fuel line and fuel pump wiring harness so that they are protected against stone impact
- ▶ Provide rub protection for fuel line and wiring harness in areas where there are sharp edges

Dismantling fuel pump connector X7

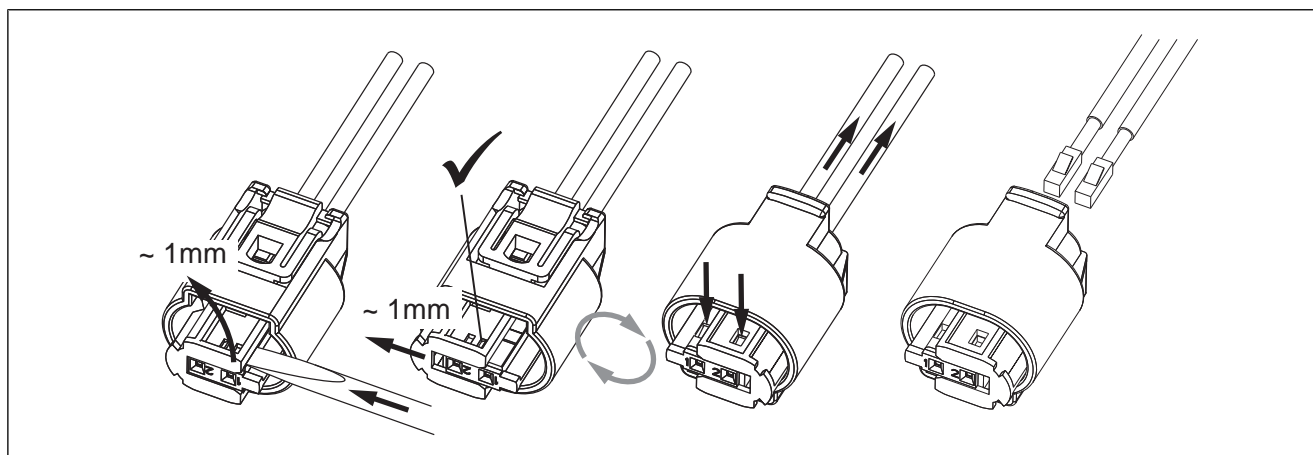

Fig. 29

9.1 Routing fuel line

Connecting heater

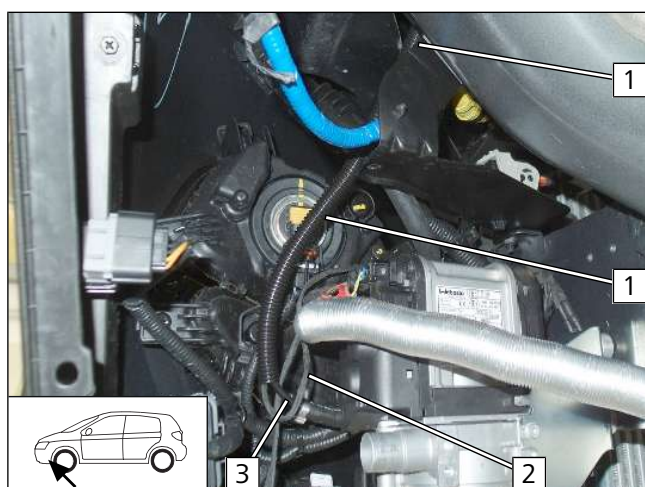

Fig. 30

- ▶ Draw fuel line **3** and fuel pump wiring harness **2** into Ø10 corrugated tube **1** and route into the engine compartment.



Installing lines

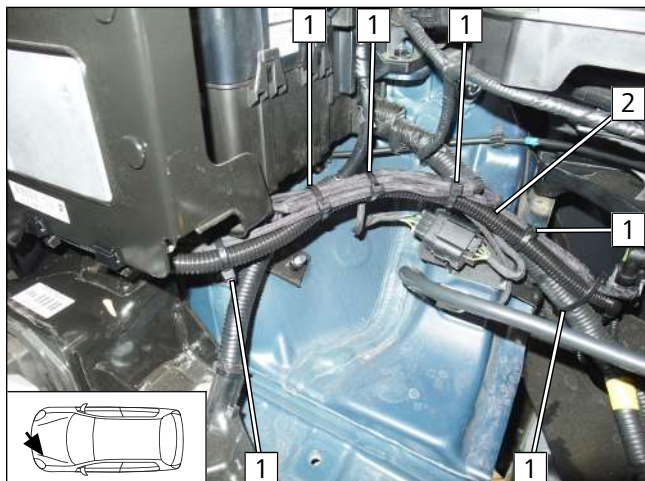

Fig. 31

- 1 Cable tie
- 2 Fuel line and fuel pump wiring harness in Ø10 corrugated tube

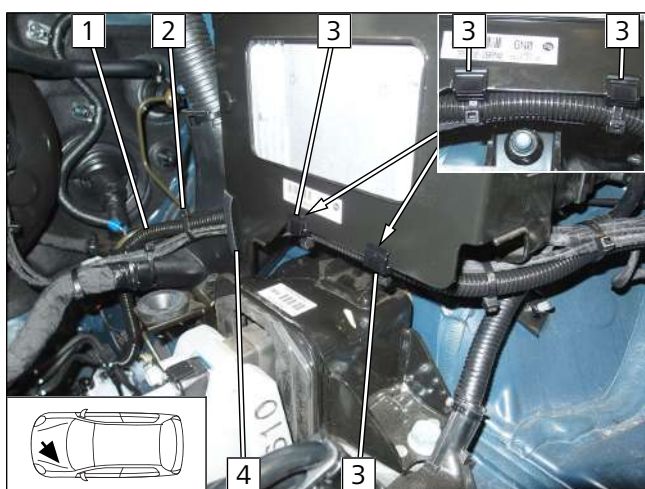

Fig. 32

- 1 Fuel line and fuel pump wiring harness in Ø10 corrugated tube
- 2 Cable tie
- 3 Edge clip cable tie
- 4 50 long edge protection

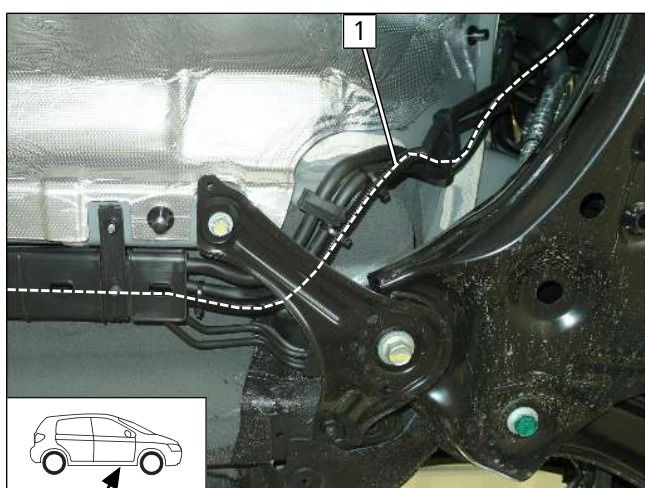

Fig. 33

- Route fuel line and fuel pump wiring harness in Ø10 corrugated tube **1** along original vehicle fuel lines to the underbody and secure with cable ties.



► Route fuel line and fuel pump wiring harness in Ø10 corrugated tube **1** along original vehicle fuel lines to fuel pump installation location and secure using cable ties.

Fig. 34

Premounting fuel pump

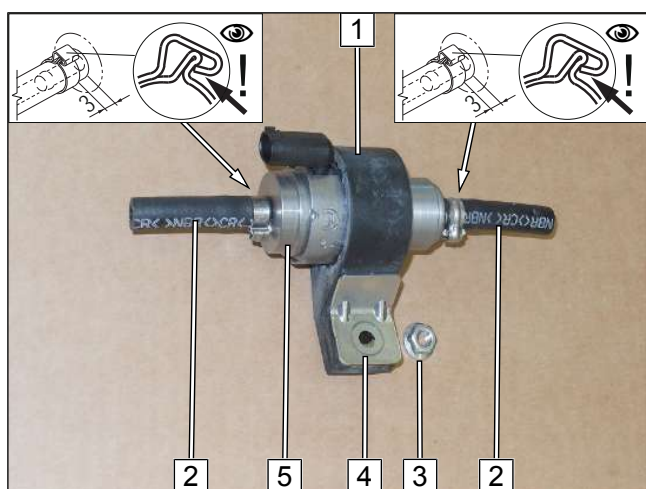

- 1** Fuel pump mount
- 2** Hose section, Ø10 clamp
- 3** Flanged nut
- 4** Support angle bracket
- 5** Fuel pump

Fig. 35

Preparing fuel pump perforated bracket

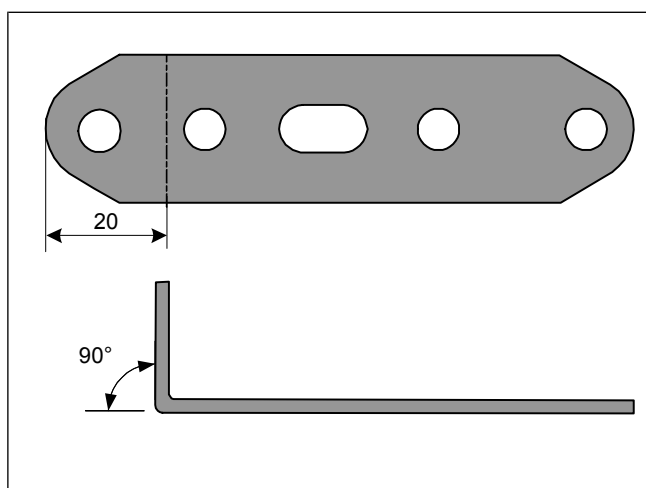

Fig. 36



Premounting fuel pump perforated bracket

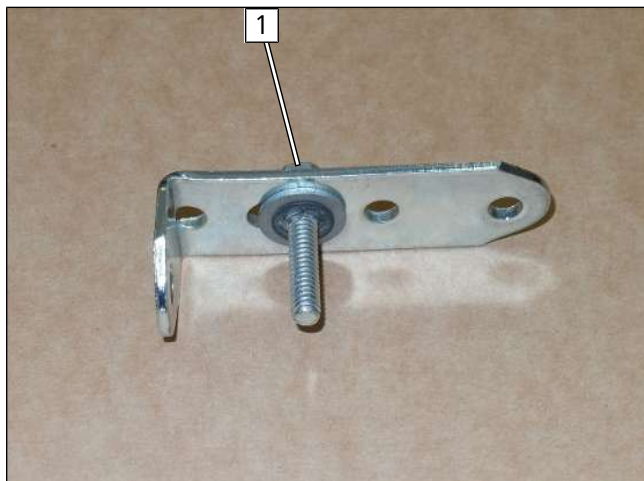

Fig. 37

- 1 M6x25 bolt, perforated bracket, large diameter washer, lock washer

Preparing fuel pump installation location

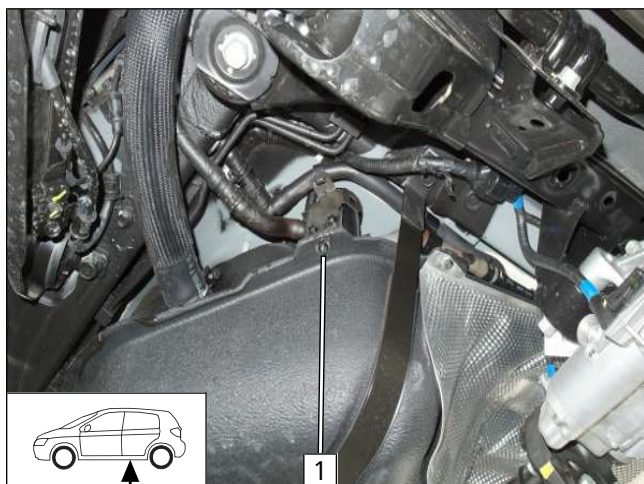

Fig. 38

- Remove original vehicle bolt 1, nut will be reused.

Mounting fuel pump perforated bracket

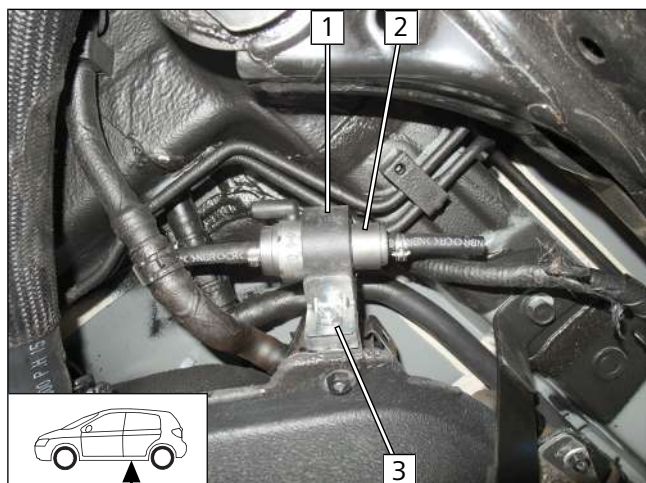

Fig. 39

- 1 M6x20 bolt, large diameter washer, perforated bracket, original vehicle hole, original vehicle nut



Mounting fuel pump



- 1 Fuel pump mount
- 2 Fuel pump
- 3 Flanged nut

Fig. 40

Assembling fuel pump connector X7

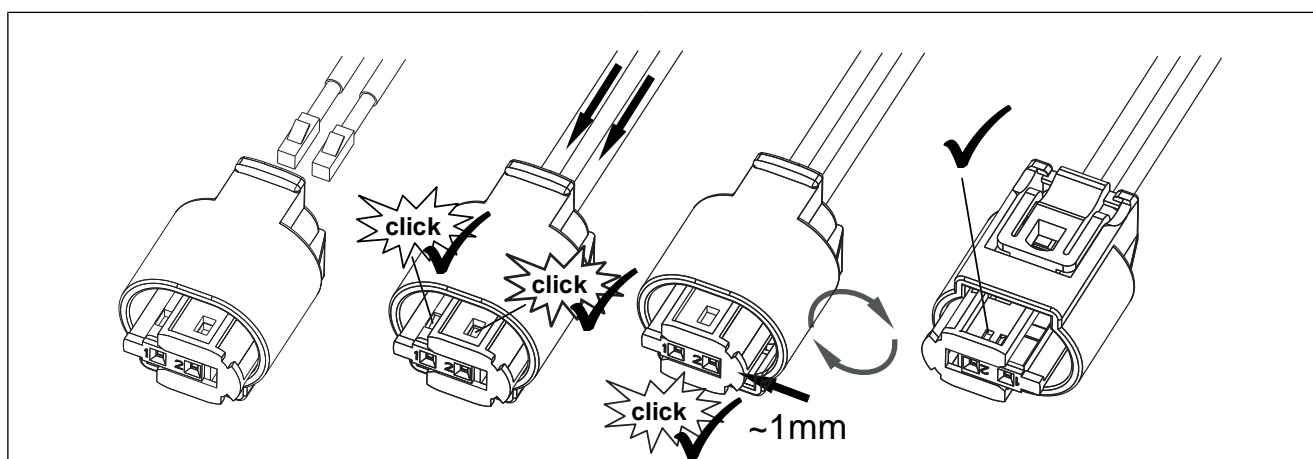
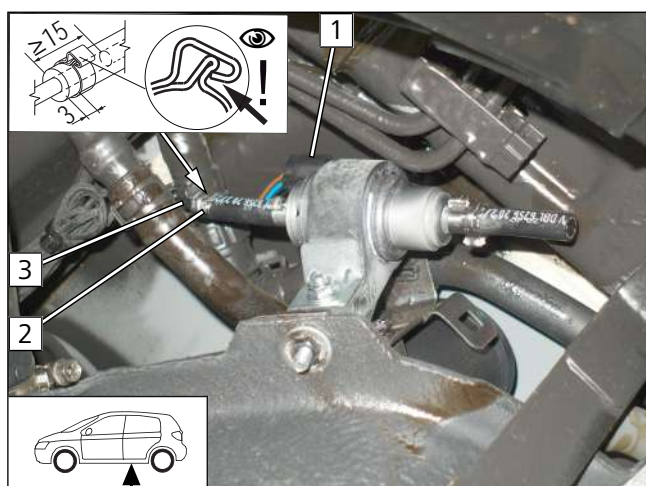

Fig. 41



- 1 Fuel pump wiring harness, connector X7 mounted
- 2 Ø10 clamp
- 3 Heater fuel line in Ø10 corrugated tube

Fig. 42



9.2 Installing FuelFix

Work steps F1, F2



Fig. 43



Observe the installation instructions of the tank extracting device.

► Mark hole pattern.

- 1 Tank fitting
- 2 Use embossed area on tank fitting to drill a hole (coloured for easier identification)

Work step F3



Fig. 44



DANGER

Risk of fire and explosion due to leaking fuel and escaping fuel vapours.

► Drill hole for FuelFix.

- 1 Hole made with provided drill

Work steps F4, F5

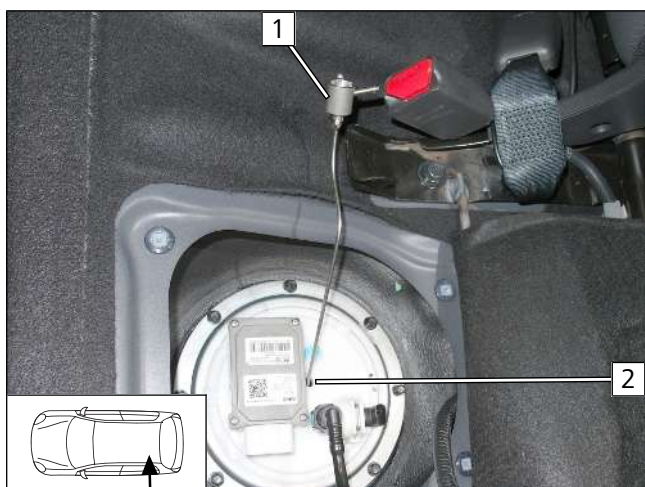

Fig. 45

► Bend FuelFix 1 as shown in template and cut to length.

► Insert FuelFix in hole 2.



Work step F5



Fig. 46



Fig. 47



Fig. 48



Fig. 49



Fig. 50

Work steps F5.3, F5.4

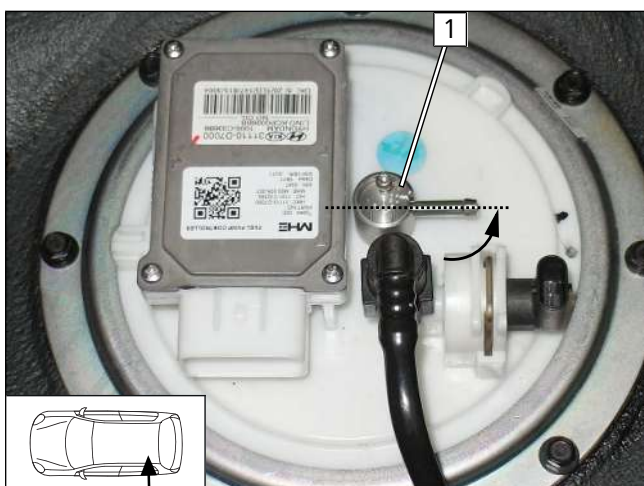

Fig. 51

► Align FuelFix **1** as shown in figure.



Work step F6

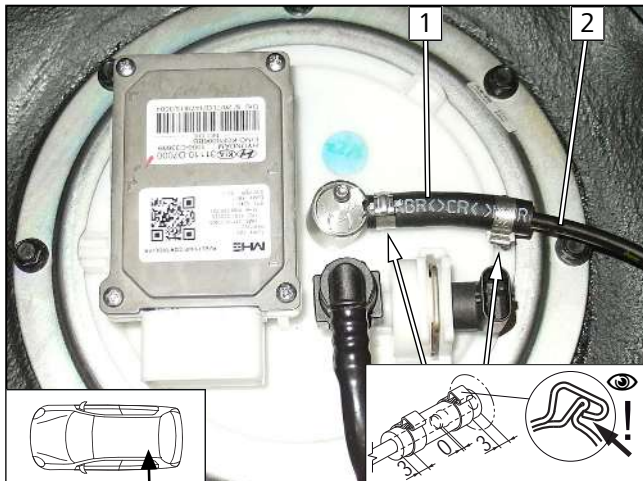

Fig. 52

- 1 Hose section, Ø10 clamp [2x]
- 2 Fuel line

Work step F7

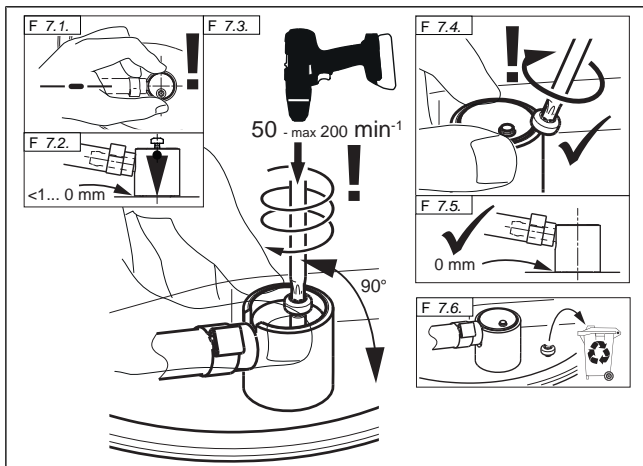



Fig. 53

 **DANGER**
Risk of fire and explosion due to leaking fuel and escaping fuel vapours

Work step F8

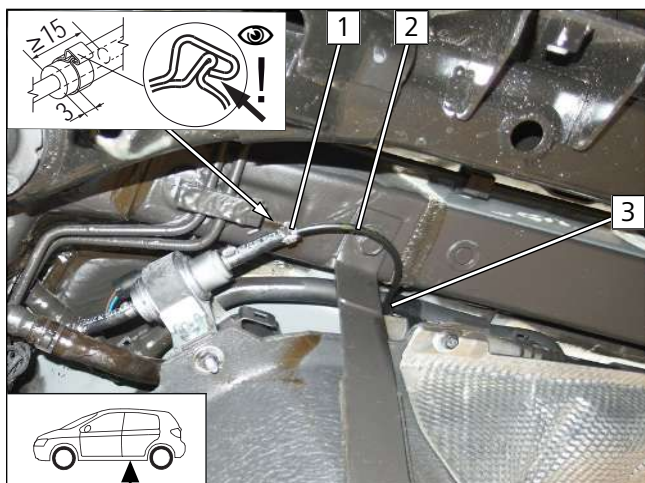

Fig. 54

- Check firm seating of FuelFix.



Securing fuel line and connecting fuel pump



- 1 Ø10 clamp
- 2 Fuel line FuelFix
- 3 Cable tie for tension relief

Fig. 55



10 Combustion air

Premounting combustion air intake silencer

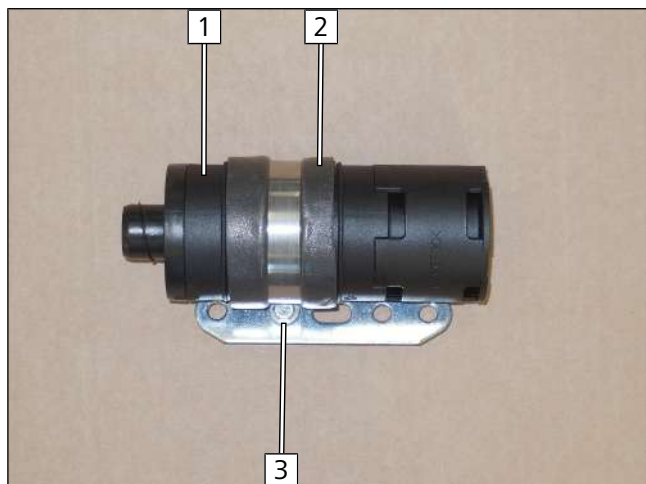

Fig. 56

- 1 Combustion air intake silencer
- 2 Self-adhesive foam
- 3 M5x16 bolt, Ø51 clamp, perforated bracket, large diameter washer, flanged nut

Mounting combustion air intake silencer

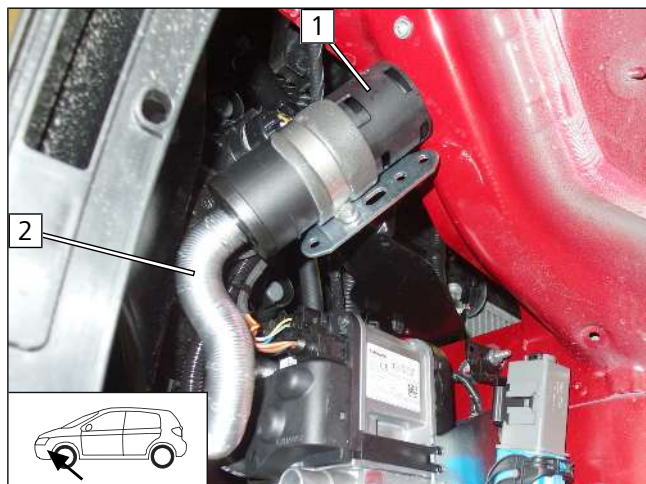

Fig. 57



Observe the installation instructions of the combustion air intake silencer.

- 1 Combustion air intake silencer
- 2 Combustion air pipe

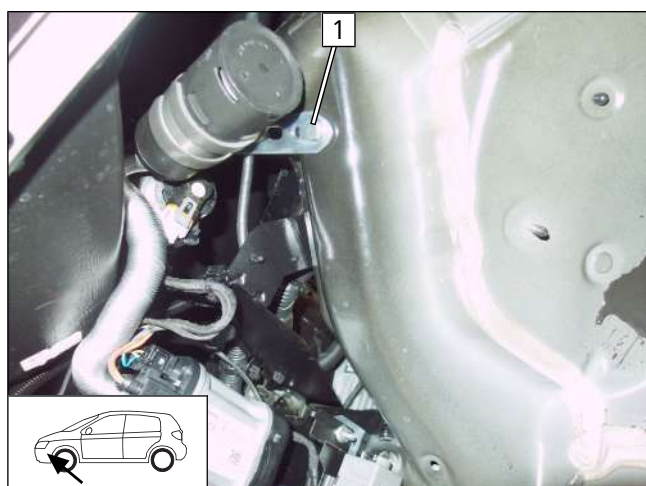

Fig. 58

- 1 M6x20 bolt, spring lockwasher, perforated bracket, rivet nut



11 Coolant for 97kW

11.1 Hose routing diagram

'Island' coolant circuit

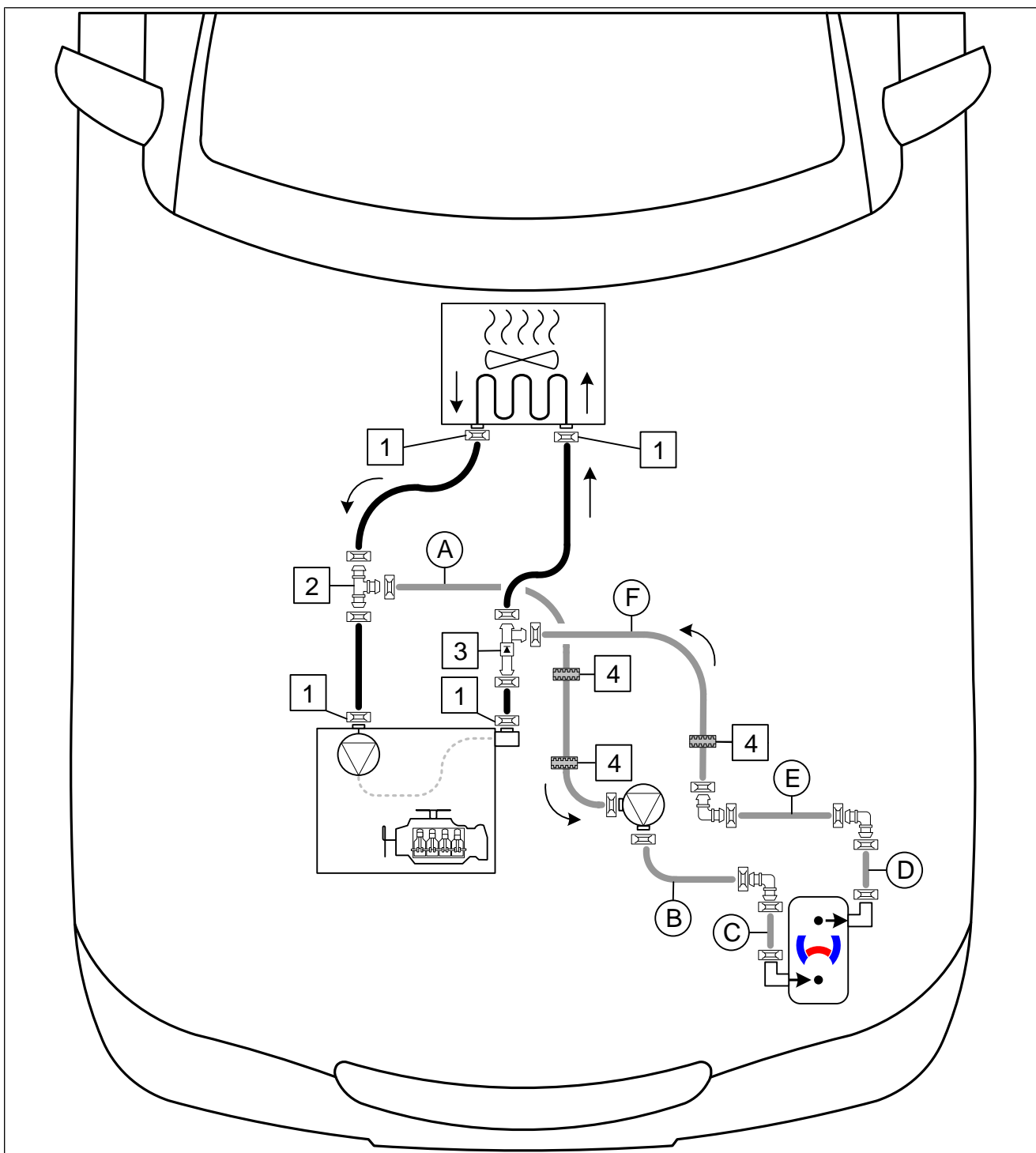



Fig. 59

All spring clips without a specific designation  = Ø25

All connecting pipes without a specific designation  = Ø18x18

1 Original vehicle spring clip; **2** T-piece; **3** non-return valve; **4** black rubber isolator



11.2 Coolant circuit installation

Removing original vehicle hose and cable holder

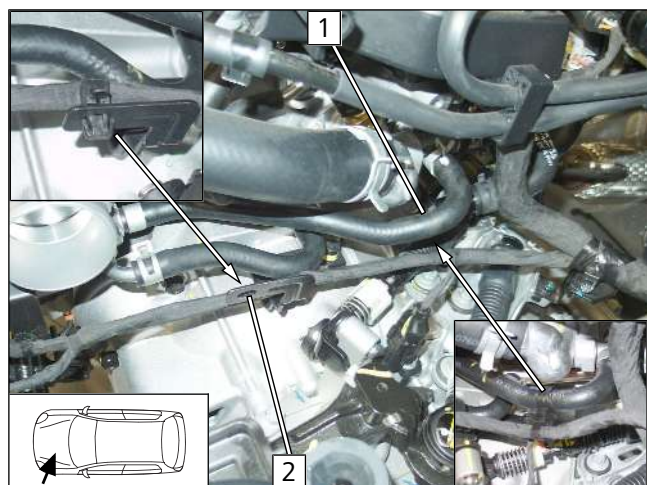

- ▶ Discard hose bracket at position **1** and cable holder at position **2**.

Fig. 60

Turning original vehicle spring clip

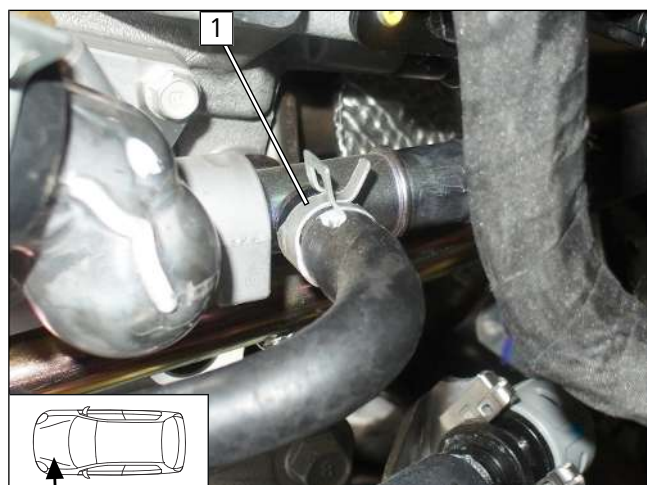

- ▶ Turn original vehicle spring clip **1** as shown.

Fig. 61

Fastening original vehicle wiring harness

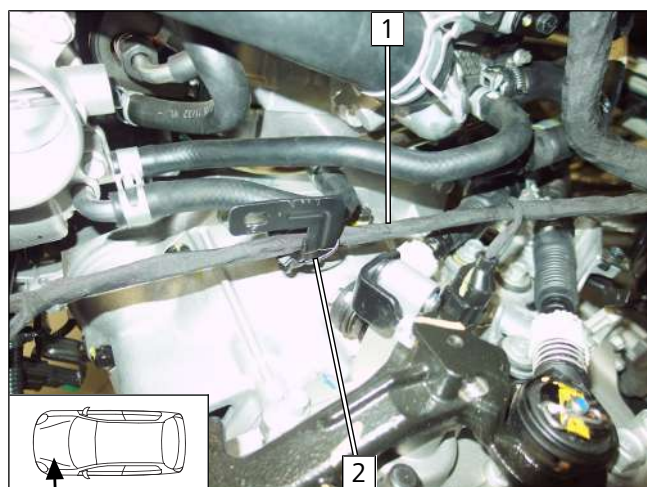

- 1** Original vehicle wiring harness
- 2** Cable tie

Fig. 62



Preparing perforated bracket A

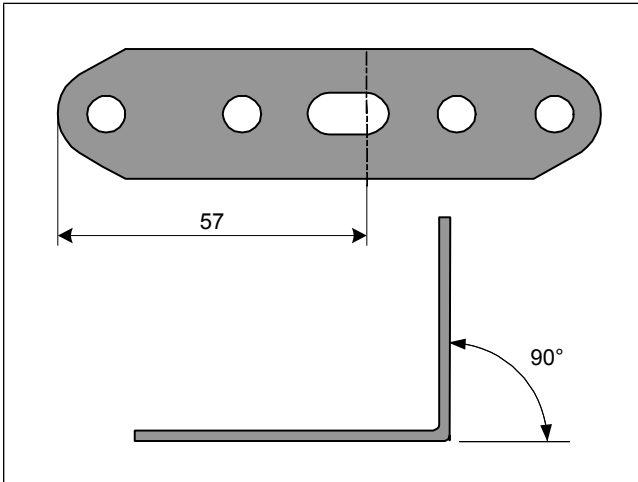

Fig. 63

Preparing perforated bracket B

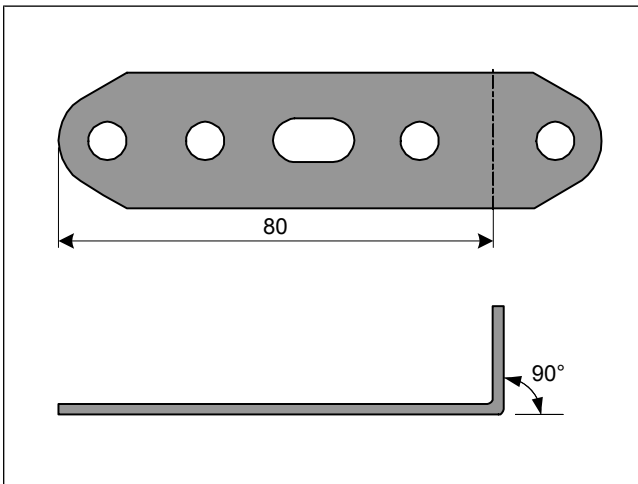
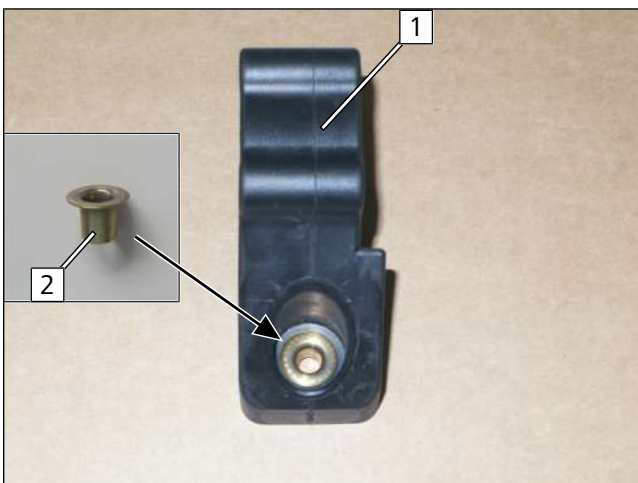

Fig. 64

Preparing coolant pump mount



- 1 Coolant pump mount
- 2 Sleeve

Fig. 65



Premounting coolant pump

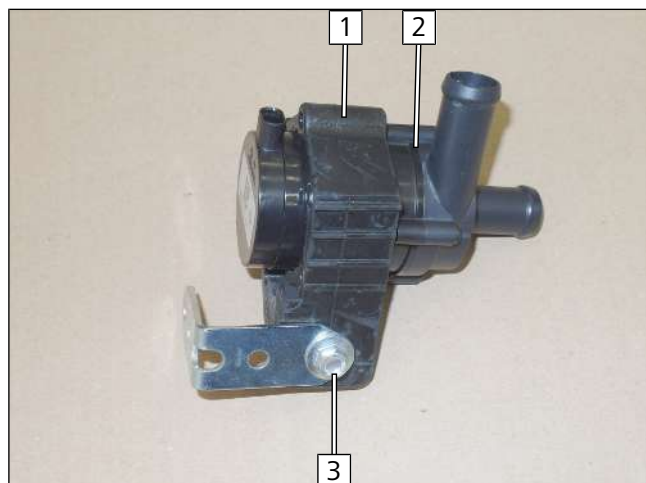

Fig. 66

- 1 Coolant pump mount
- 2 Coolant pump
- 3 M6x25 bolt, coolant pump mount, perforated bracket A, large diameter washer, flanged nut

Mounting coolant pump

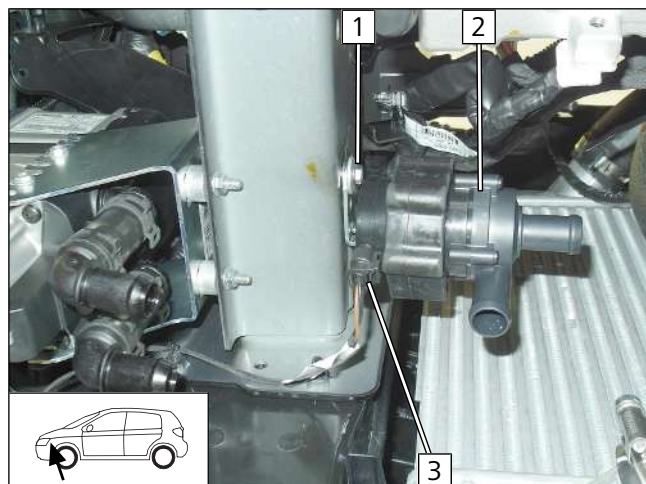

Fig. 67

- 1 M6x20 bolt, spring lockwasher, perforated bracket, rivet nut
- 2 Coolant pump
- 3 Coolant pump wiring harness connector

Mounting perforated bracket B

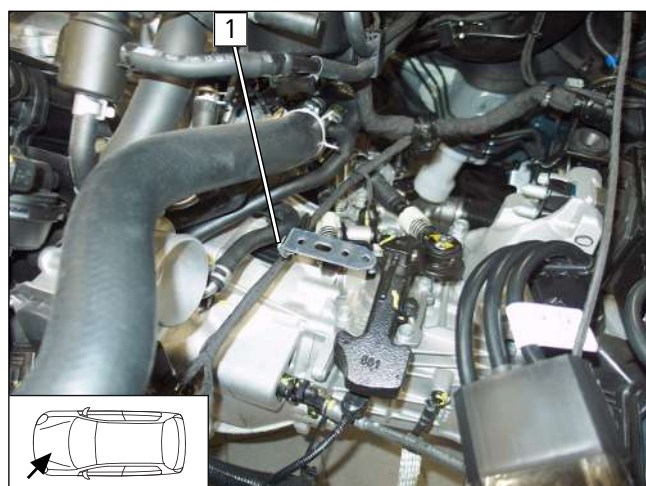

Fig. 68

- 1 M6x20 bolt, large diameter washer, original vehicle bracket, perforated bracket B, flanged nut



Mounting fabric heat shrink tubings and rubber isolators

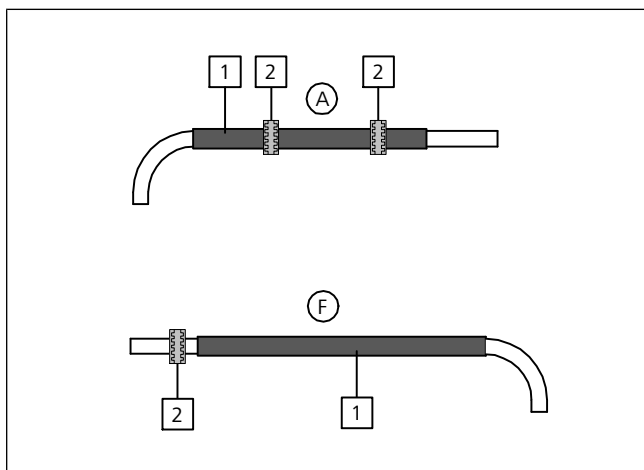

Fig. 69

- ▶ Push fabric heat shrink tubings **1** onto hose **(A)** and hose **(F)**, cut to length and shrink.
- ▶ **2** Position black (sw) rubber isolator

Mounting heat protection hose

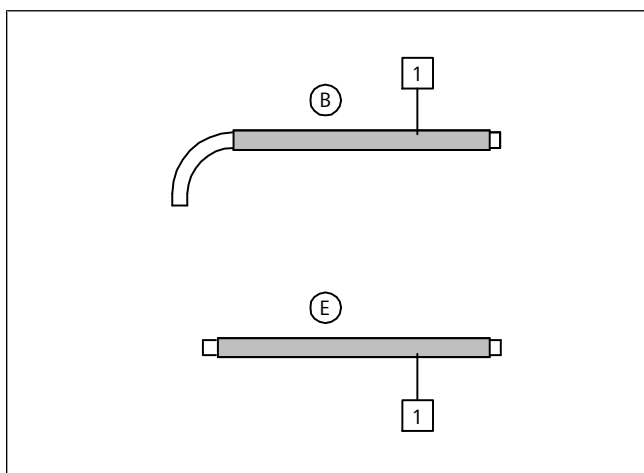

Fig. 70

- ▶ Cut heat protection hose to length and push onto hose **(B)** and hose **(E)**.
- ▶ **1** Heat protection hose

Dismantling hoses

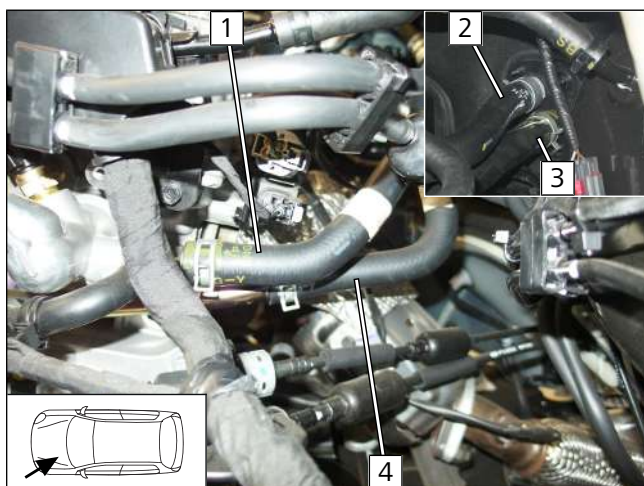

Fig. 71

- ▶ Remove engine outlet / heat exchanger inlet hose **1** / **3** from the connection piece.
- ▶ Remove engine inlet / heat exchanger outlet hose **4** / **2** from the connection piece.
- ▶ Original vehicle spring clips will be reused.



Preparing hose of engine outlet / heat exchanger inlet

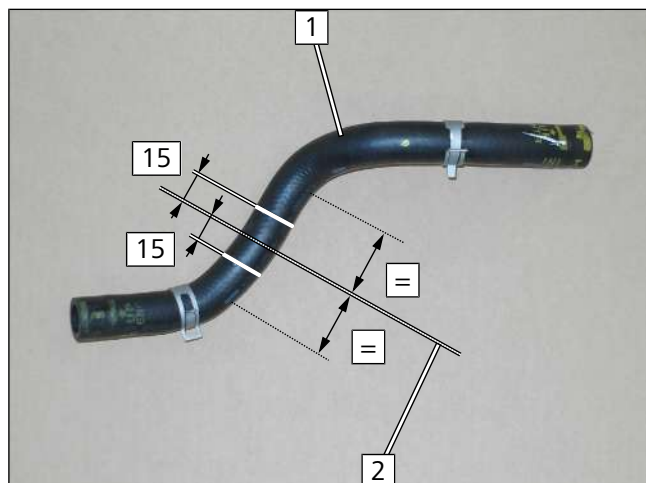

Fig. 72

- ▶ Remove the sticker at the centre line **2** on the hose.
- ▶ Draw 2 markings on the hose as shown in Fig.
 - 1** Engine outlet / heat exchanger inlet hose
 - 2** Centre line between the neighbouring elbows

Cutting point 1

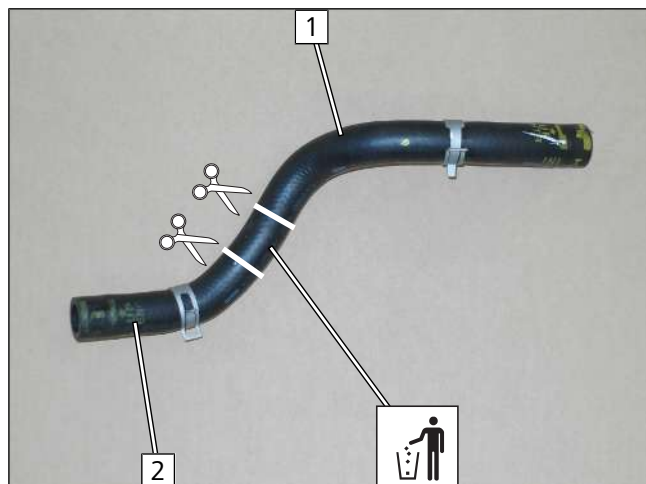

Fig. 73

- 1** Heat exchanger inlet hose section
- 2** Engine outlet hose section

Mounting non-return valve

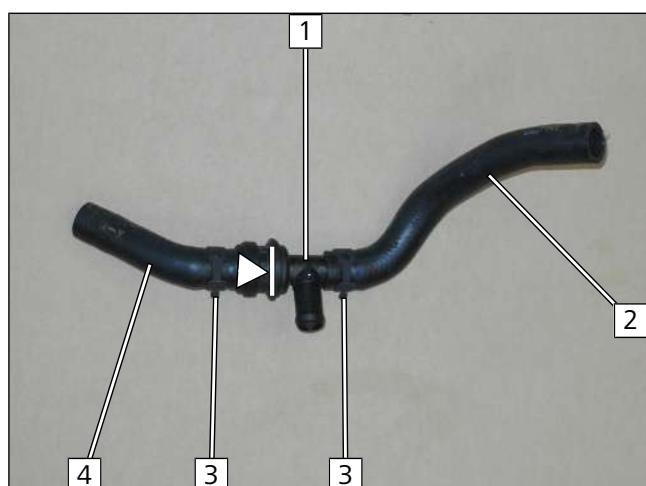

Fig. 74

- 1** Non-return valve
- 2** Heat exchanger inlet hose section
- 3** Ø25 spring clip
- 4** Engine outlet hose section



Premounting hose ①

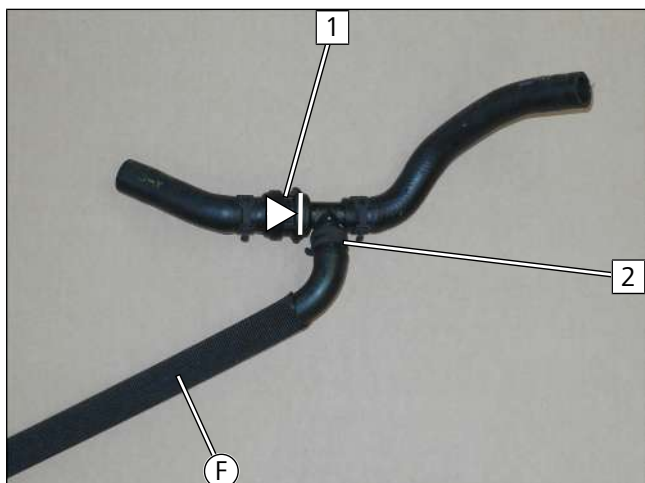

Fig. 75

- 1 Non-return valve
- 2 Ø25 spring clip

Premounting engine inlet/heat exchanger outlet hose

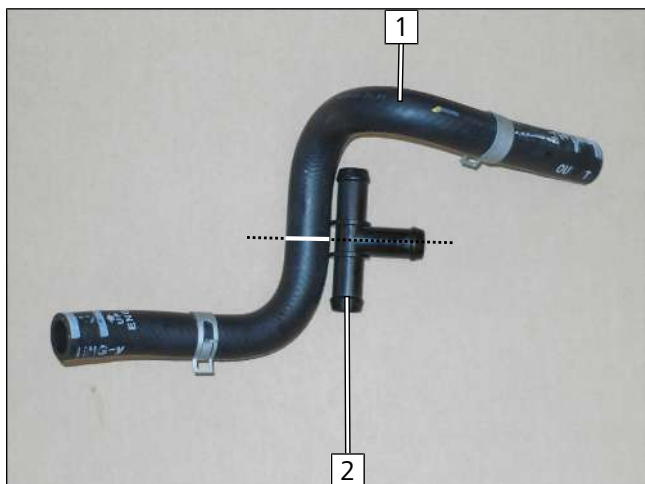

Fig. 76

- ▶ Remove sticker from hose.
- ▶ Draw 1 marking on the hose as shown in Fig.
 - 1 Engine inlet / heat exchanger outlet hose
 - 2 T-piece, positioned at the middle of the hose

Cutting point 2

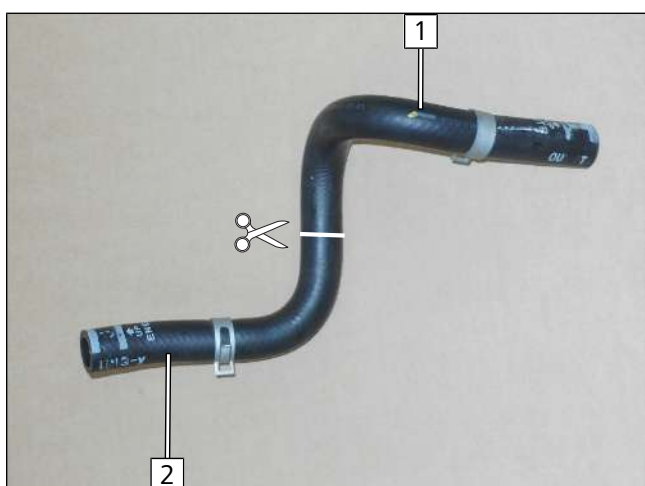

Fig. 77

- 1 Heat exchanger outlet hose section
- 2 Engine inlet hose section



Mounting T-piece

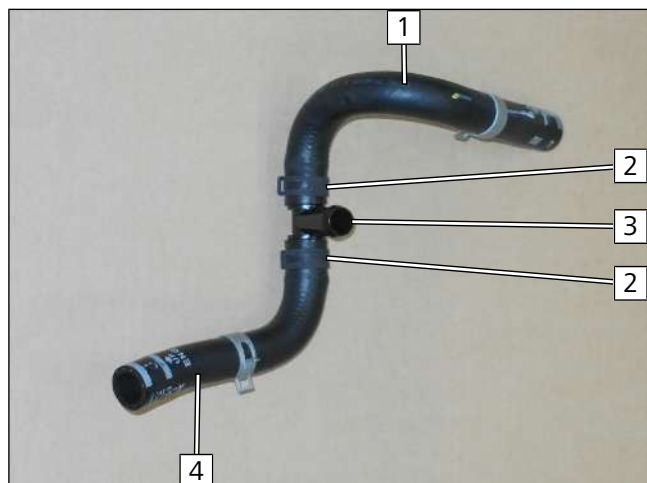

Fig. 78

- 1 Heat exchanger outlet hose section
- 2 Ø25 spring clip
- 3 T piece
- 4 Engine inlet hose section

Premounting hose (A)

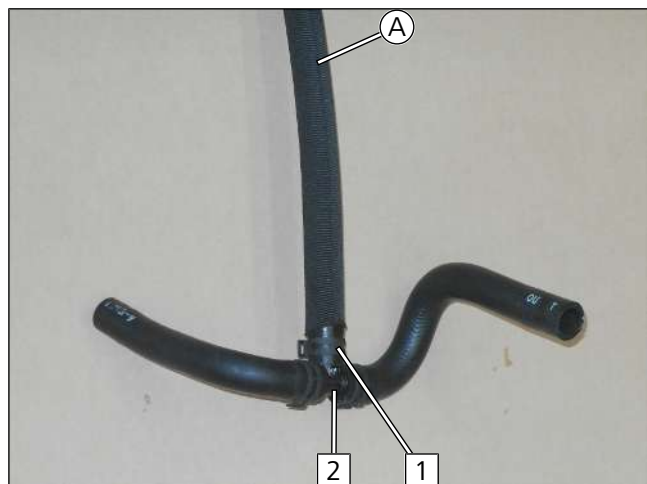

Fig. 79

- 1 Ø25 spring clip
- 2 T piece

Heater outlet connection

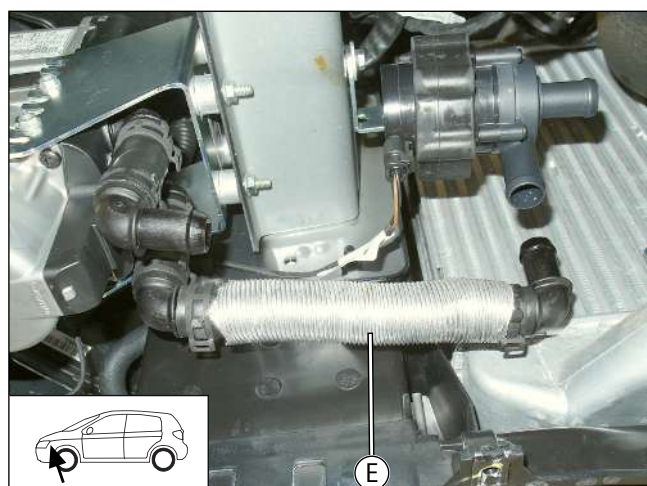

Fig. 80



Heater inlet and coolant pump outlet connection

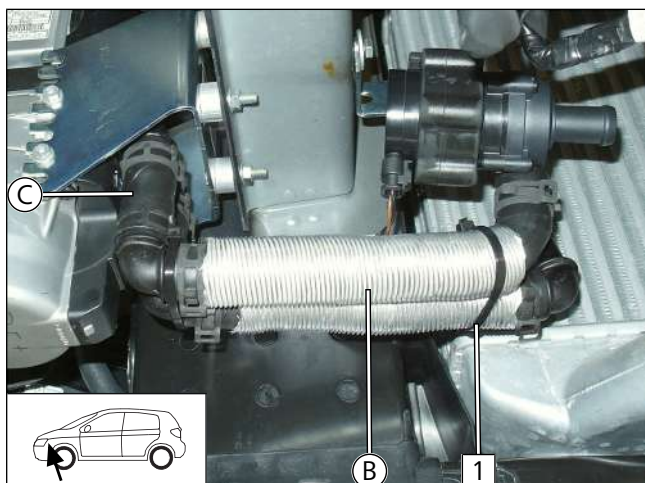

Fig. 81

- 1 Cable tie

Connection of engine inlet/heat exchanger outlet

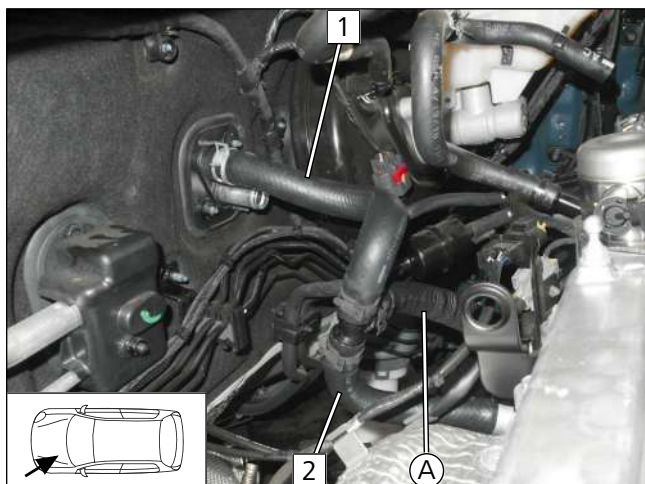

Fig. 82

- 1 Heat exchanger outlet hose section
- 2 Engine inlet hose section

Routing hose (A)

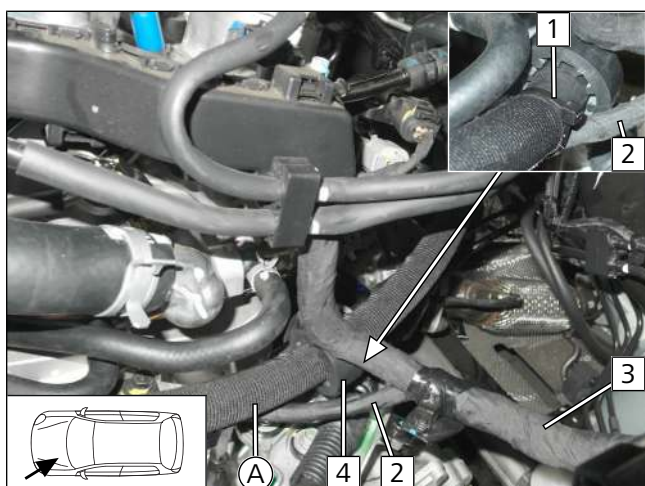

Fig. 83

- ▶ Route hose (A) under original vehicle wiring harness 3.
- ▶ Align black (sw) rubber isolator 4 as shown.
- ▶ Fasten black (sw) rubber isolator 4 to original vehicle wiring harness 2 using cable tie 1.



Coolant pump inlet connection

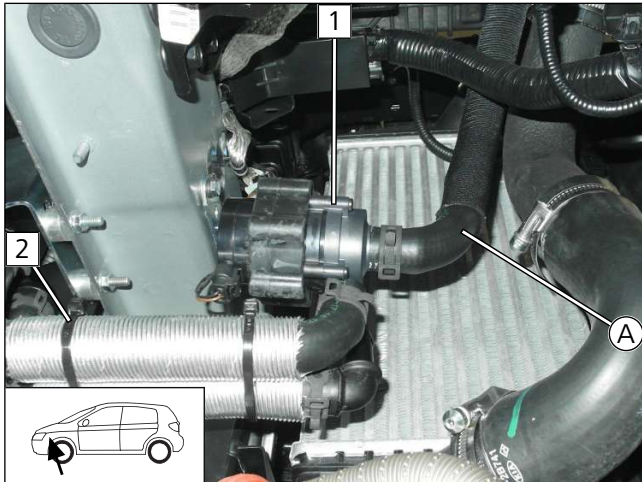

Fig. 84

- 1 Coolant pump

Heat exchanger inlet connection

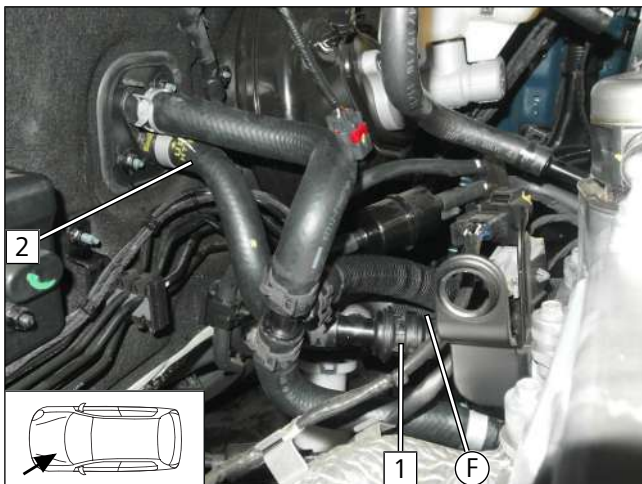

Fig. 85

- 1 Non-return valve
- 2 Heat exchanger inlet hose section

Engine outlet connection

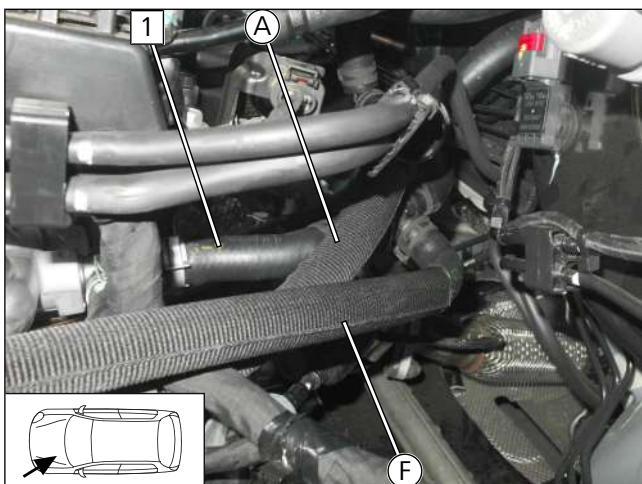

Fig. 86

► Route hose **F** above original vehicle wiring harness.

- 1 Engine outlet hose section



Routing hoses **A** and **F**

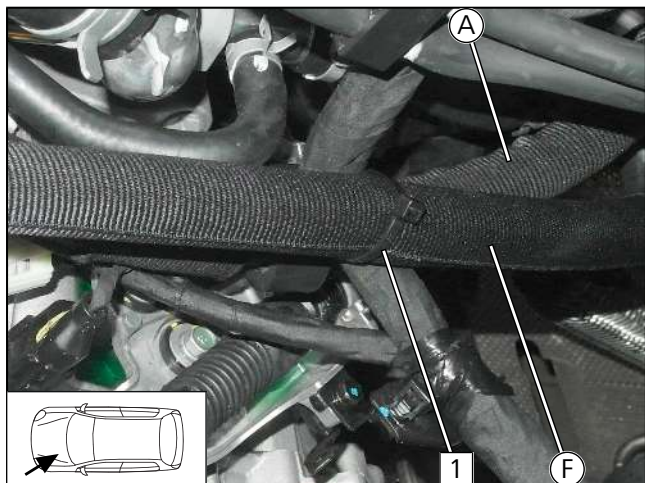

Fig. 87

- 1 Cable tie around hose **F** and original vehicle wiring harness

Heater outlet connection

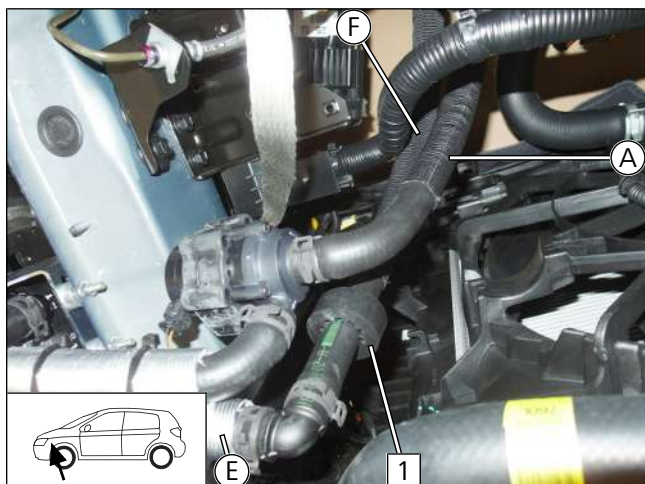

Fig. 88

- 1 Black (sw) rubber isolator

Aligning and fastening hoses



Fig. 89



Danger of damage to components

- Ensure sufficient distance from neighbouring components, correct if necessary.

- 1 M6x20 bolt, pre-mounted perforated bracket B, Ø38 rubber-coated p-clamp, flanged nut

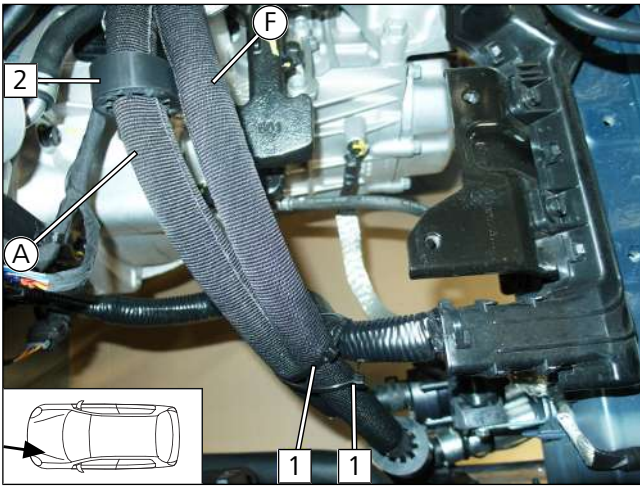

Fig. 90

► The alignment of black (sw) rubber isolator **2** will be carried out as described in section 'Final work in engine compartment'.

- 1 Cable tie around hoses **A** and **F** and original vehicle wiring harness

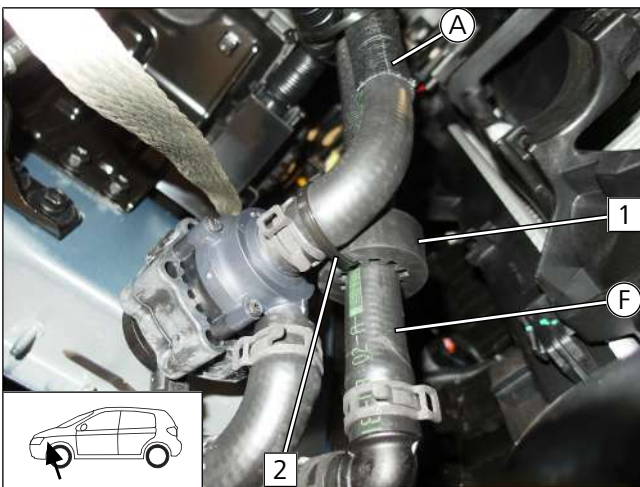

Fig. 91

► Align black (sw) rubber isolator **1** with coolant pump and secure using cable tie **2** as shown.



12 Coolant for 130kW

12.1 Hose routing diagram

'Island' coolant circuit

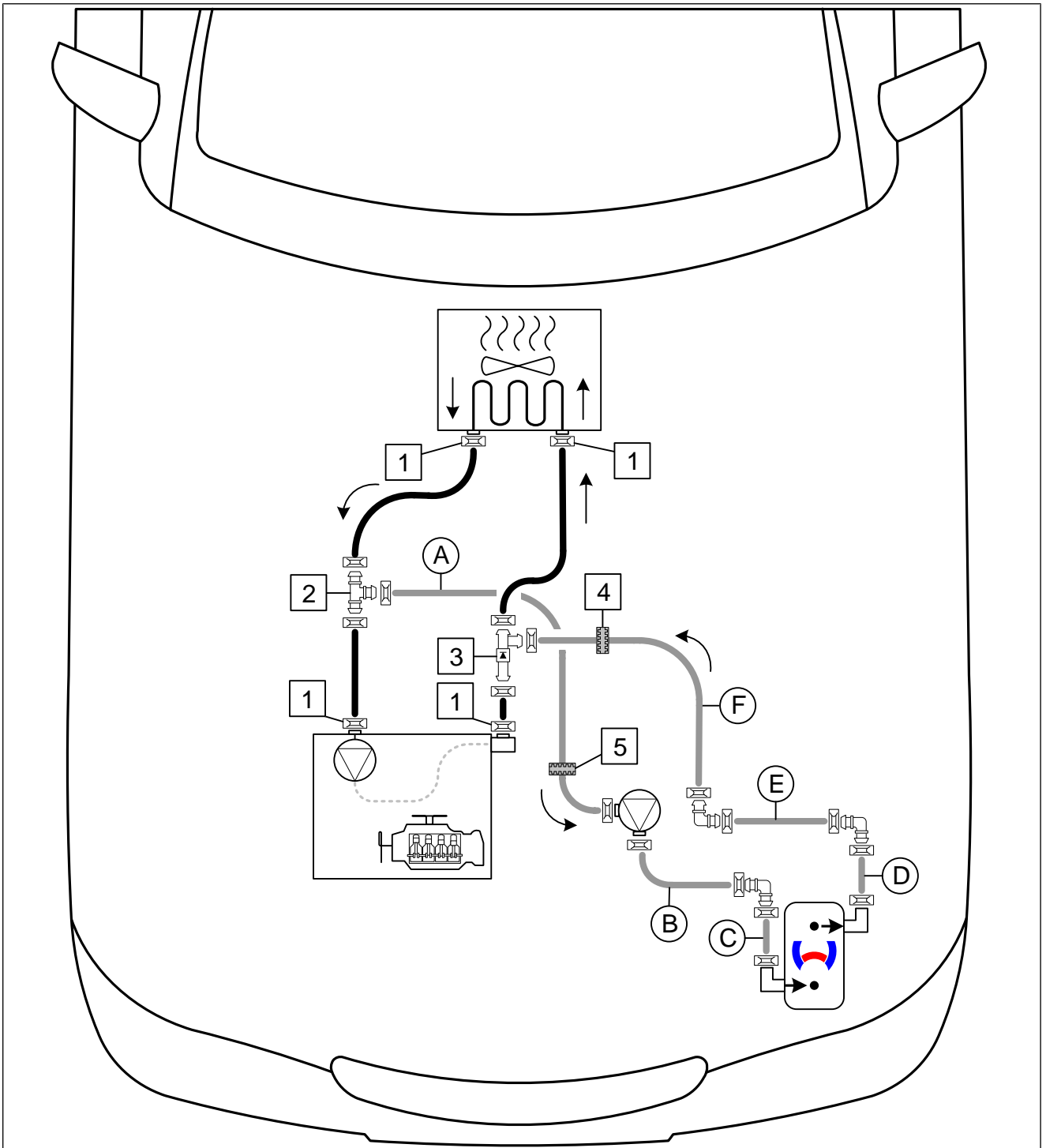



Fig. 92

All spring clips without a specific designation  = Ø25

All connecting pipes without a specific designation  = Ø18x18

1 Original vehicle spring clip; **2** T-piece; **3** non-return valve; **4** Black rubber isolator;

5 Black rubber isolator (only for vehicles with AG)



12.2 Coolant circuit installation

Preparing hoses

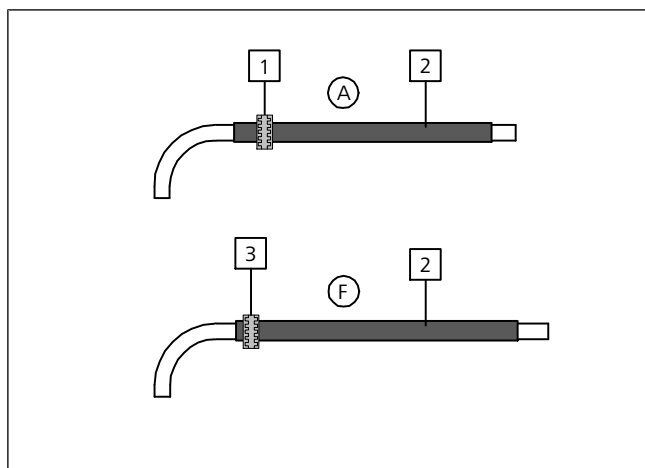

Fig. 93

- ▶ Push fabric heat shrink tubings **2** onto hose **A** and hose **F**, cut to length and shrink.
- ▶ Black (sw) rubber isolator at position **1** only in case of vehicles with AG.
- ▶ **3** Black (sw) rubber isolator

Preparing hoses

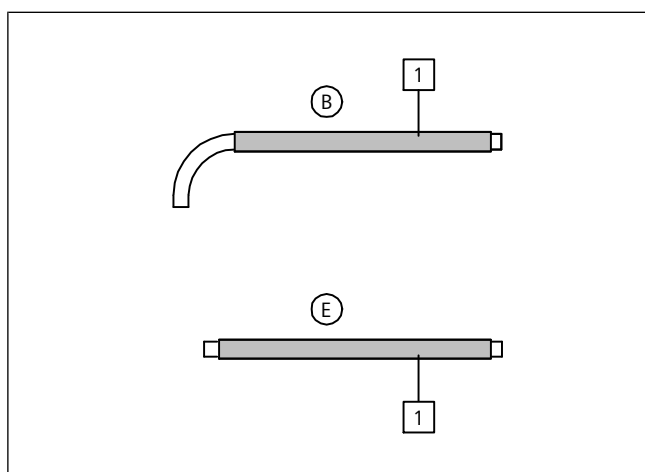

Fig. 94

- ▶ Cut heat protection hose **1** to length and push onto hose **B** and hose **E**.

Dismantling hoses

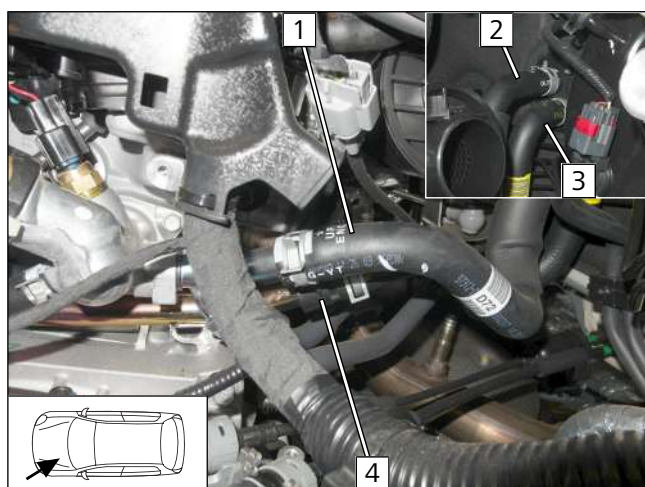



Fig. 95

 Figure shows vehicle with SG but applies also to vehicles with AG.

- ▶ Remove engine outlet / heat exchanger inlet hose **1** / **2** from the connection piece.
- ▶ Remove engine inlet / heat exchanger outlet hose **4** / **3** from the connection piece.
- ▶ Original vehicle spring clips will be reused.



Preparing hose of engine outlet / heat exchanger inlet

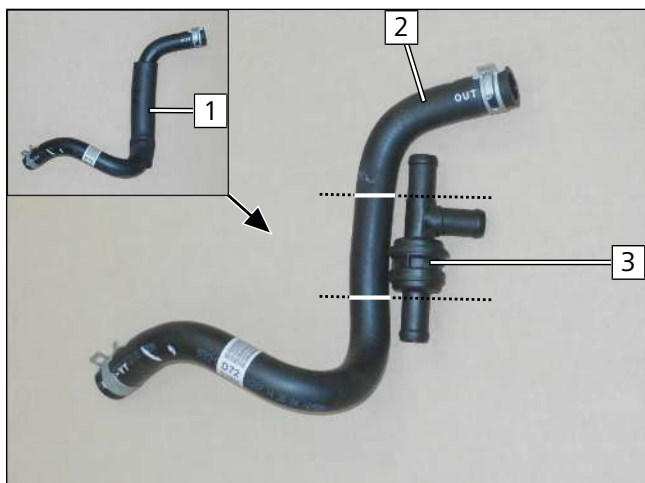

Fig. 96

► Draw 2 markings on the hose as shown in Fig.

- 1 Remove original vehicle protective sleeving
- 2 Engine outlet / heat exchanger inlet hose
- 3 Position non-return valve at the middle of the hose

Cutting point 1

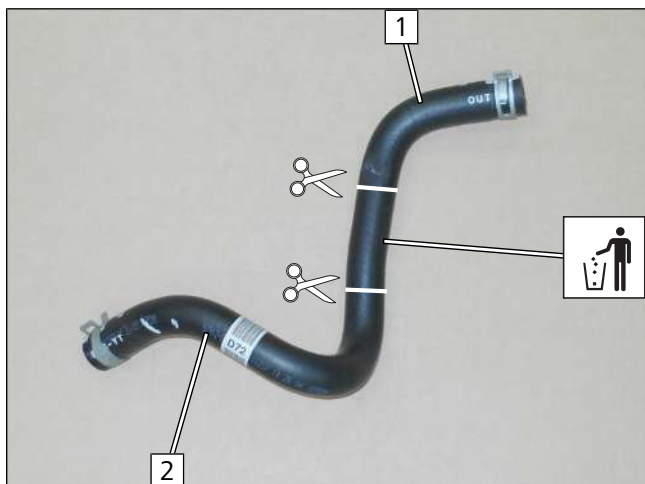

Fig. 97

- 1 Heat exchanger inlet hose section
- 2 Engine outlet hose section

Mounting non-return valve

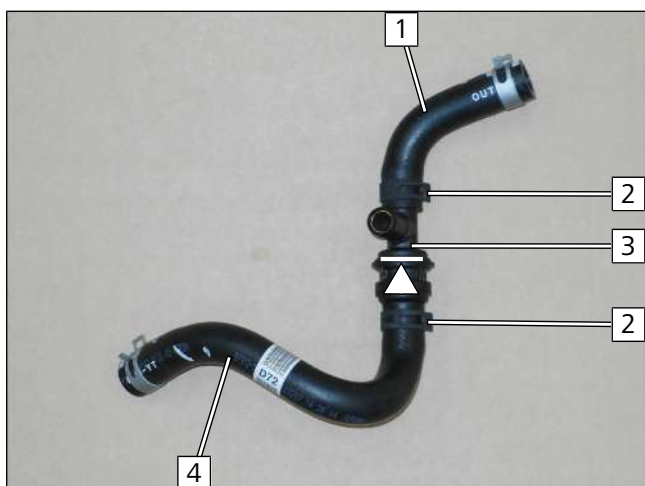

Fig. 98

- 1 Heat exchanger inlet hose section
- 2 Ø25 spring clip
- 3 Non-return valve
- 4 Engine outlet hose section



Premounting hose (F)

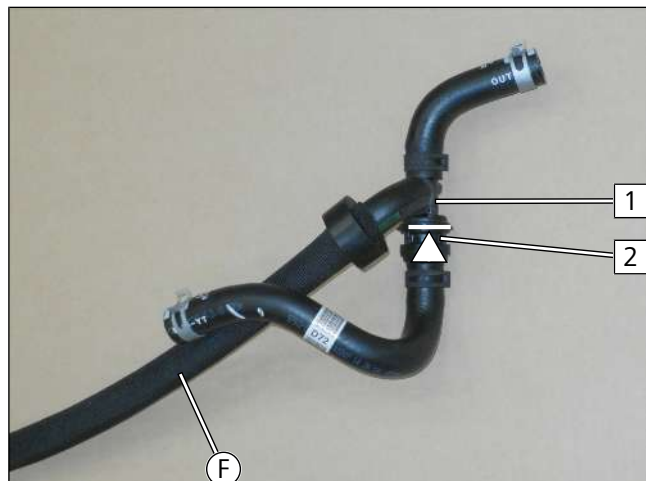

Fig. 99

- 1 Ø25 spring clip
- 2 Non-return valve

Premounting engine inlet/heat exchanger outlet hose

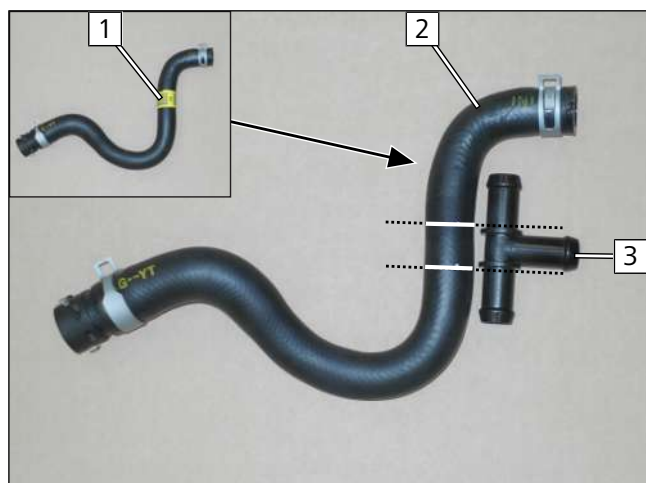

Fig. 100

► Draw 2 markings on the hose as shown in Fig.

- 1 Remove sticker
- 2 Engine inlet / heat exchanger outlet hose
- 3 T-piece, positioned at the middle of the hose

Cutting point 2

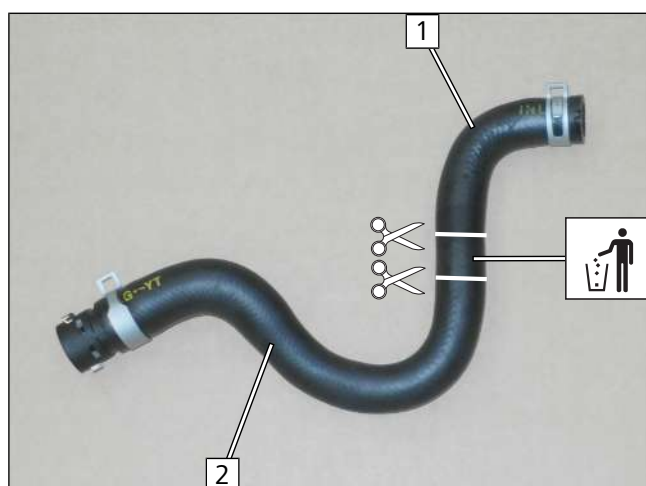

Fig. 101

- 1 Heat exchanger outlet hose section
- 2 Engine inlet hose section



Mounting T-piece

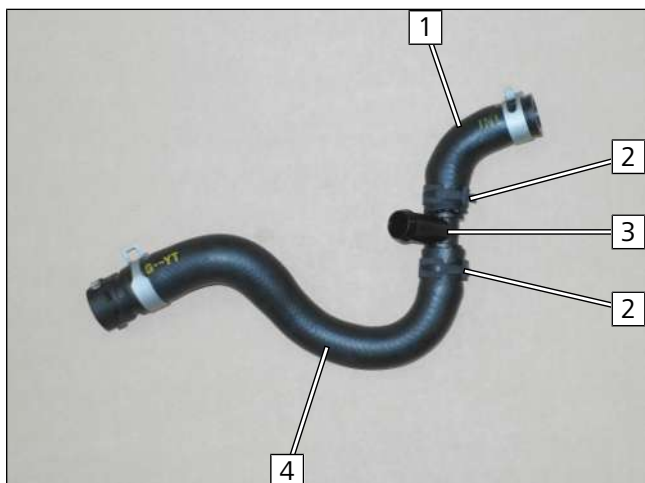

Fig. 102

- 1 Heat exchanger outlet hose section
- 2 Ø25 spring clip
- 3 T piece
- 4 Engine inlet hose section

Premounting hose (A)

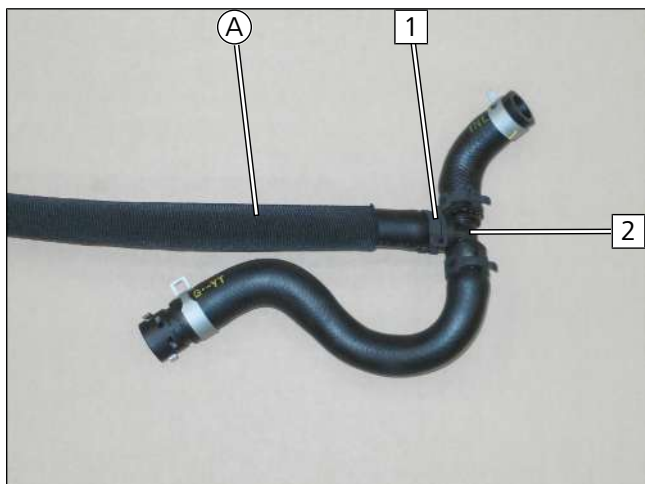

Fig. 103

- 1 Ø25 spring clip
- 2 T piece

Preparing coolant pump perforated bracket

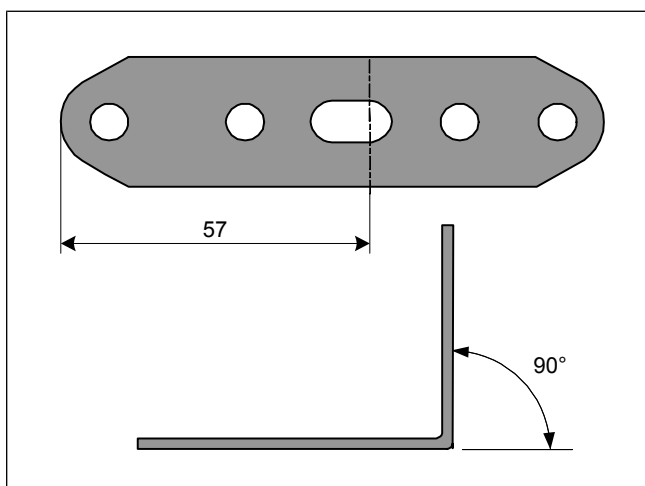

Fig. 104



Preparing coolant pump mount

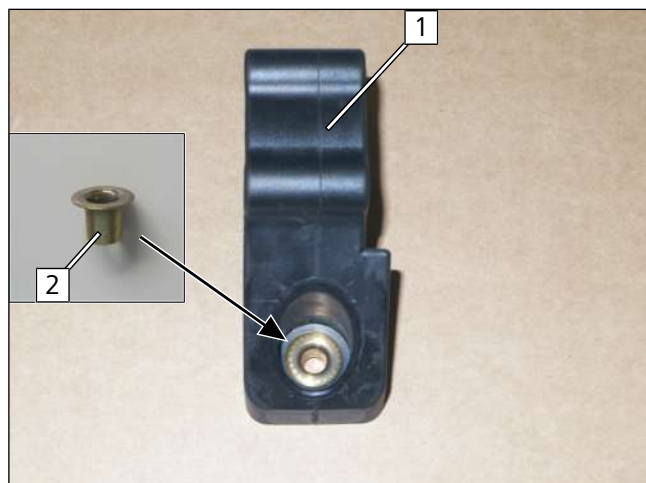

Fig. 105

- 1 Coolant pump mount
- 2 Sleeve

Premounting coolant pump

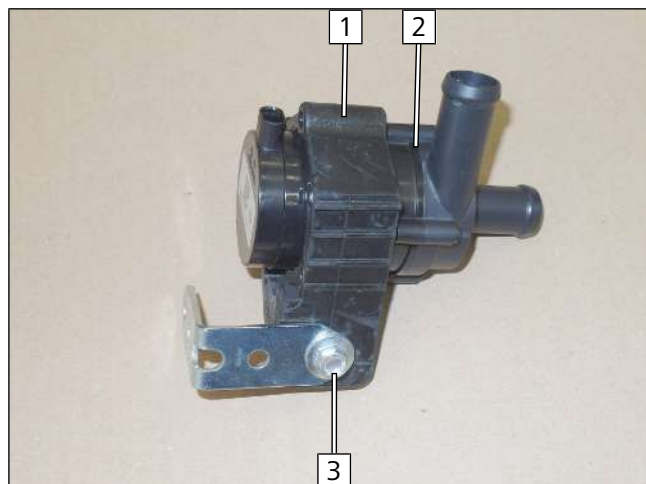

Fig. 106

- 1 Coolant pump mount
- 2 Coolant pump
- 3 M6x25 bolt, coolant pump mount, perforated bracket A, large diameter washer, flanged nut

Mounting coolant pump

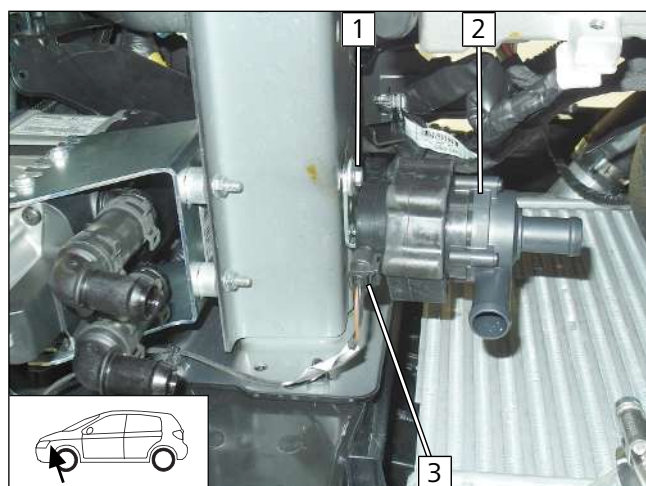

Fig. 107

- 1 M6x20 bolt, spring lockwasher
- 2 Coolant pump
- 3 Coolant pump wiring harness connector



Heater outlet connection

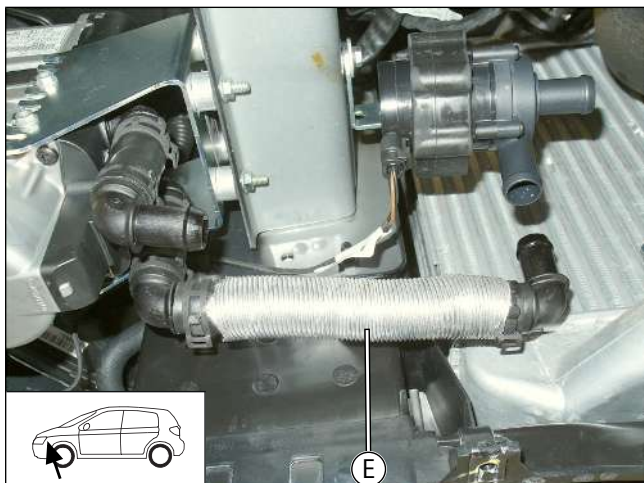

Fig. 108

Heater inlet and coolant pump outlet connection

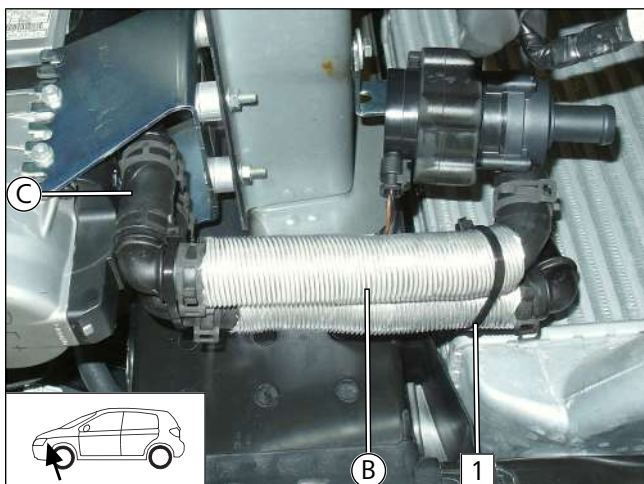

Fig. 109

- 1 Cable tie

Connection of engine inlet/heat exchanger outlet

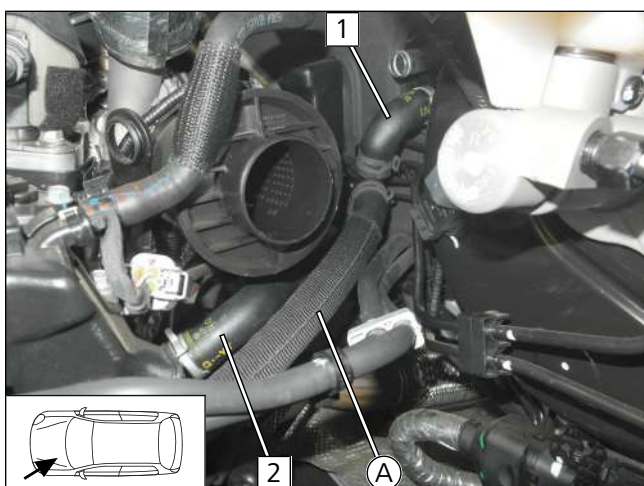

Fig. 110

- 1 Heat exchanger outlet hose section
- 2 Engine inlet hose section



Routing hose **A**

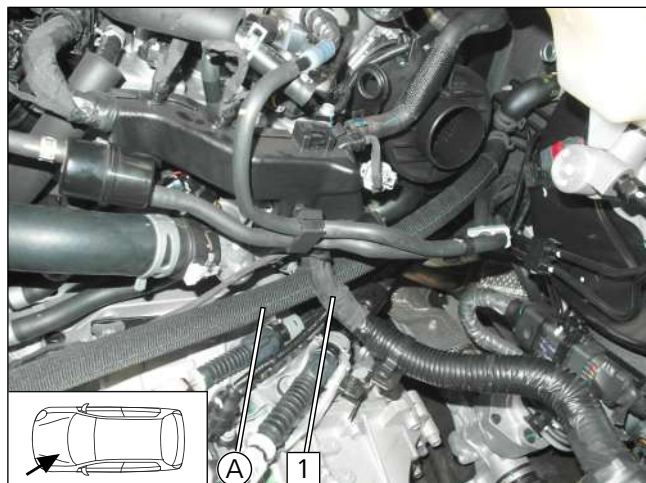

Fig. 111

- ▶ Route hose **A** under original vehicle wiring harness **1**.

Coolant pump inlet connection

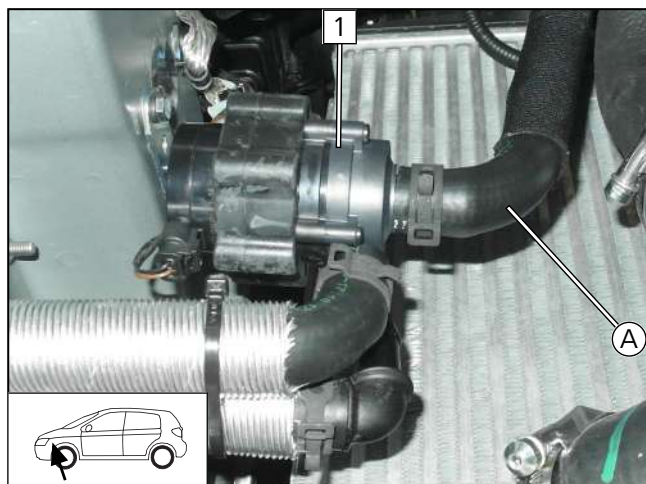

Fig. 112

- 1** Coolant pump

Heat exchanger inlet connection

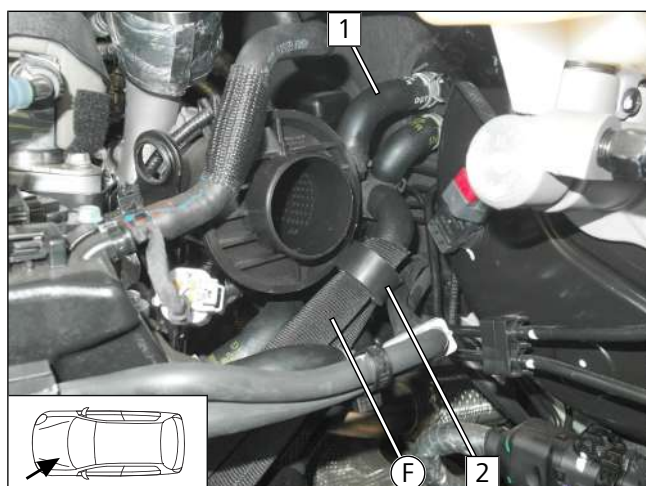

Fig. 113

- ▶ Align black (sw) rubber isolator **2** with intake pipe and fuel line.

- 1** Heat exchanger inlet hose section



Engine outlet connection

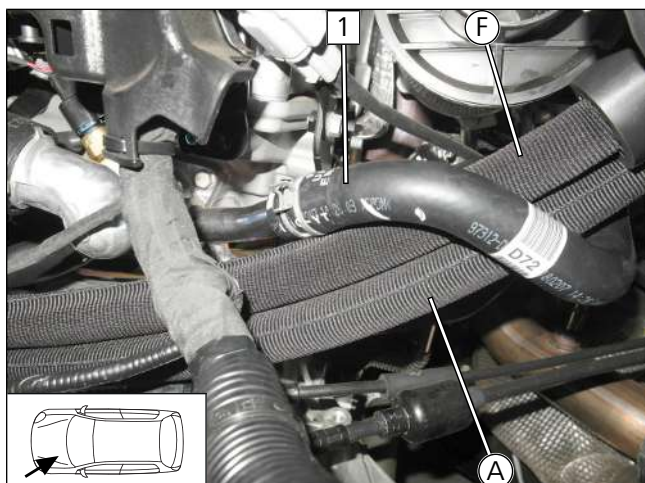

Fig. 114



Vehicle with manual transmission

► Route hose (F) under original vehicle wiring harness.

1 Engine outlet hose section

Routing hoses (A) and (F)

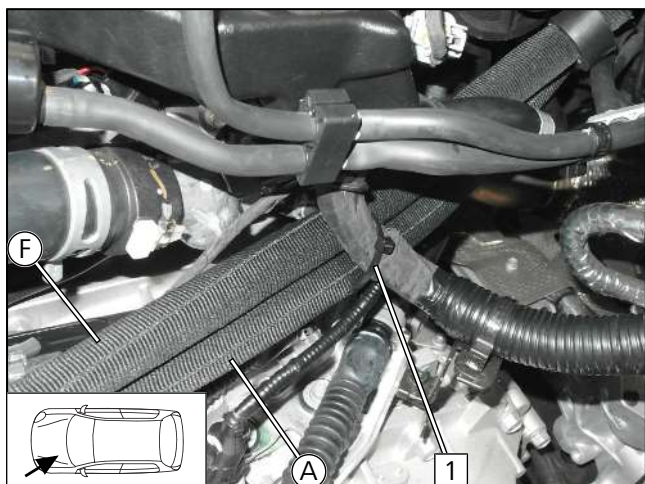

Fig. 115

1 Cable tie around hoses (A) and (F) and original vehicle wiring harness

Heater outlet connection

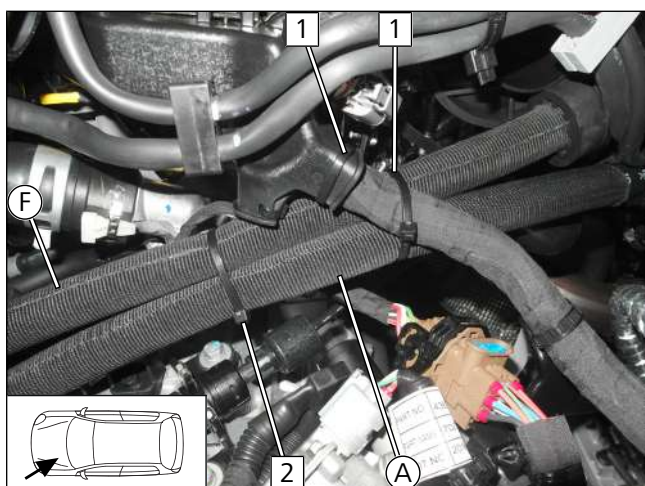

Fig. 116

1 Cable tie around hoses (A) and (F) and original vehicle wiring harness

2 Cable tie around hoses (A) and (F)



Aligning and fastening hoses

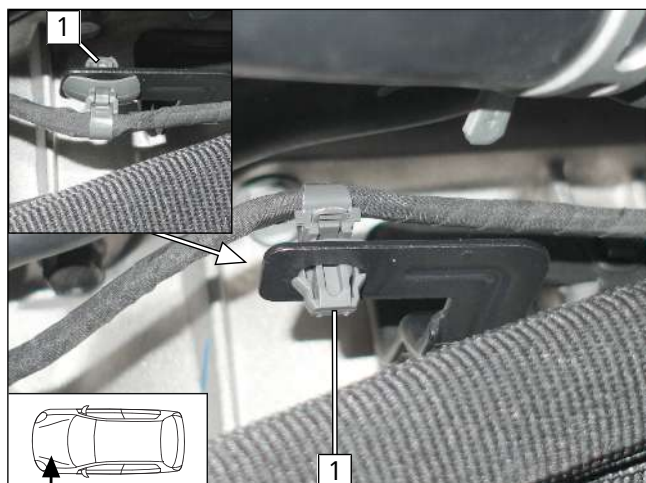

Fig. 117

- ▶ Detach original vehicle eyelet cable tie **1** and insert again in the bracket, turned the other way round as shown.

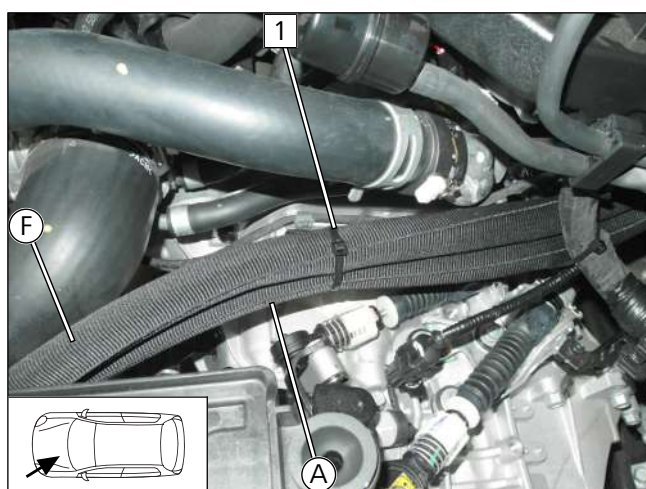

Fig. 118

- 1** Cable tie around hoses **(A)** and **(F)** and cable bracket

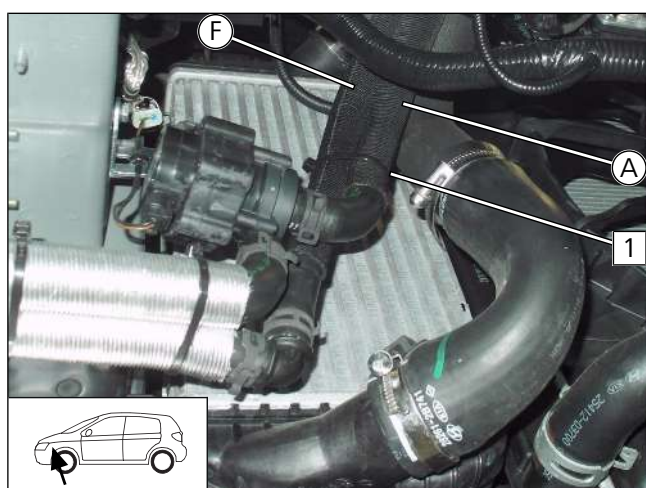

Fig. 119



Danger of damage to components

- ▶ Ensure sufficient distance from neighbouring components, correct if necessary.

- 1** Cable tie



Engine outlet connection

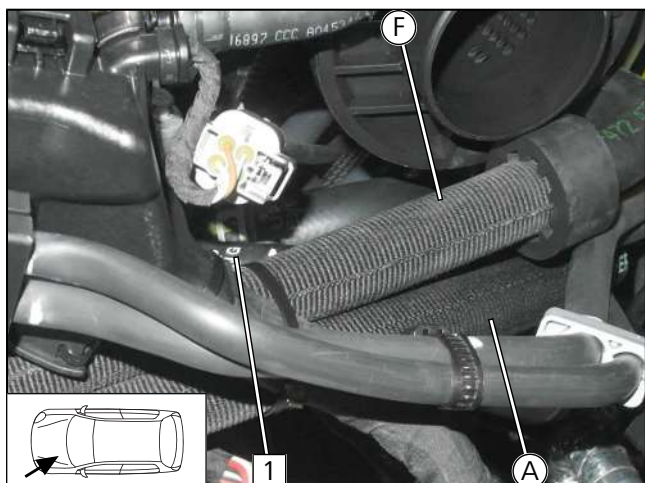

Fig. 120



Vehicle with automatic transmission

► Route hose (F) under original vehicle wiring harness.

- 1 Engine outlet hose section

Routing hoses (A) and (F)

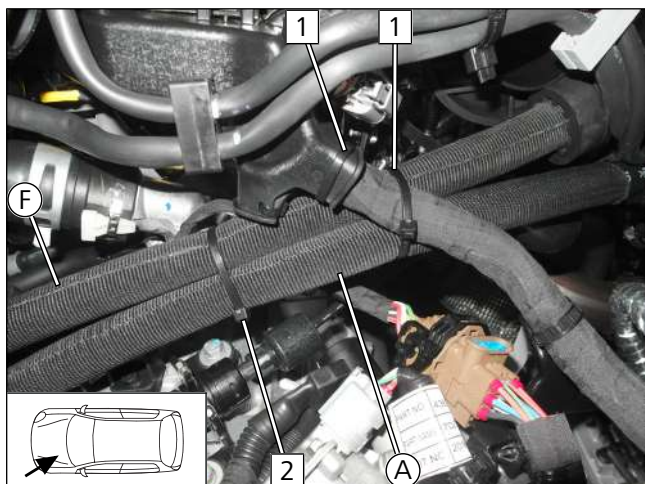

Fig. 121

- 1 Cable tie around hoses (A) and (F) and original vehicle wiring harness

- 2 Cable tie around hoses (A) and (F)

Heater outlet connection

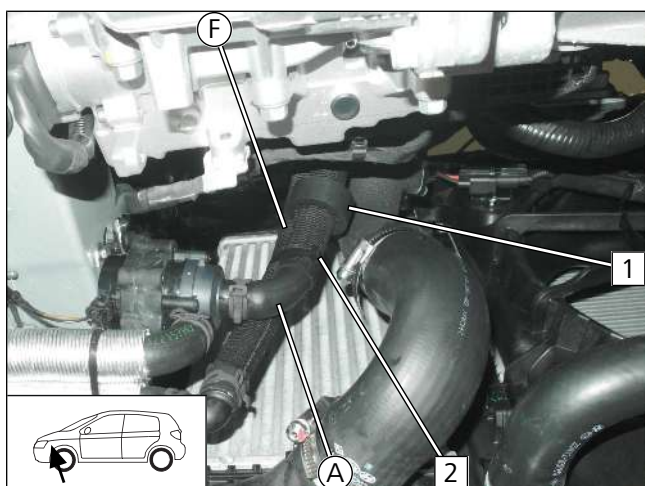

Fig. 122

- 1 Position black (sw) rubber isolator

- 2 Cable tie around hoses (A) and (F)



Aligning and fastening hoses

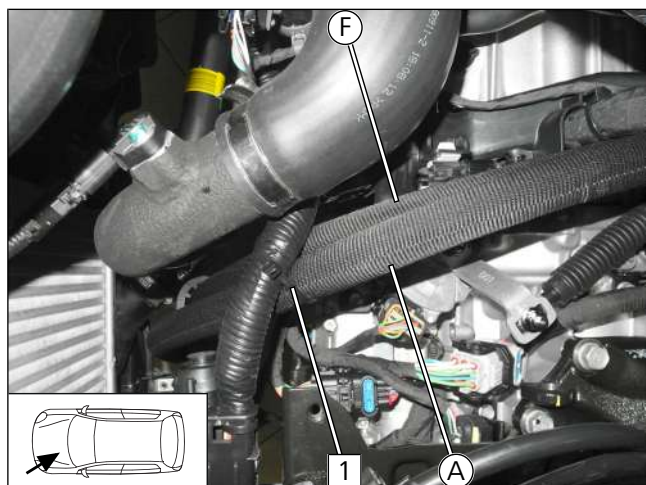

Fig. 123



Danger of damage to components

► Ensure sufficient distance from neighbouring components, correct if necessary.

1 Cable tie



13 Exhaust

13.1 Mounting exhaust pipe

Cutting exhaust pipe to length

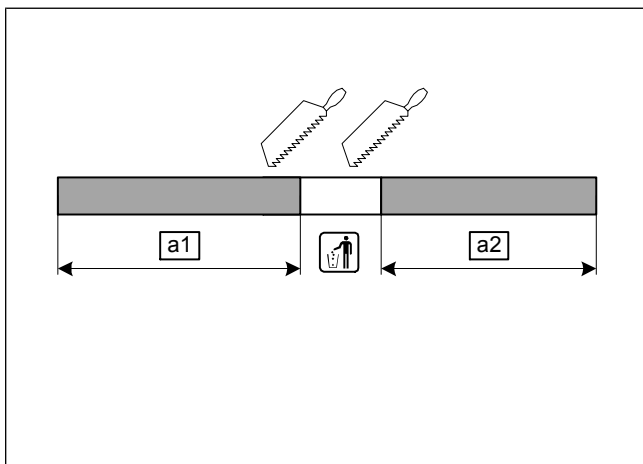

a1 270

a2 250

Fig. 124

Preparing perforated bracket

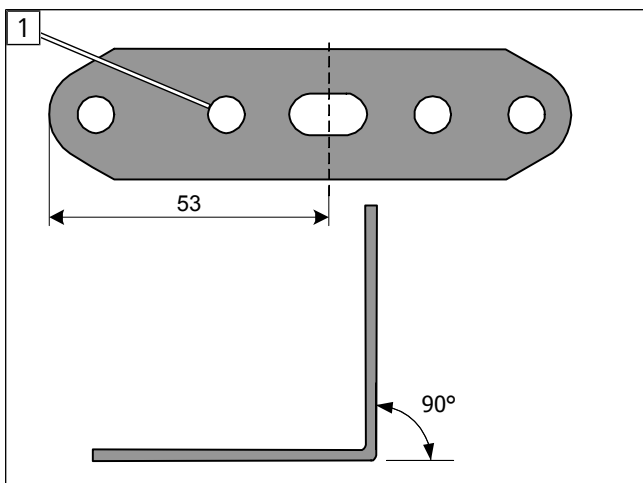

1 Exhaust silencer fixing point

Fig. 125

Premounting exhaust silencer

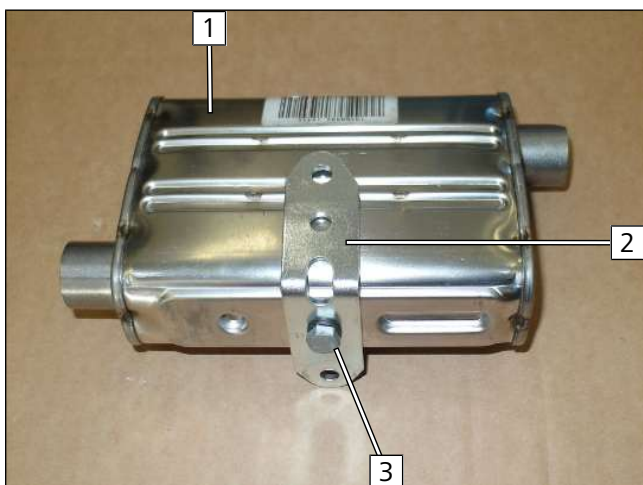

1 Exhaust silencer

2 Perforated bracket

3 M6x16 bolt, spring lockwasher

Fig. 126



Affixing heat protection film

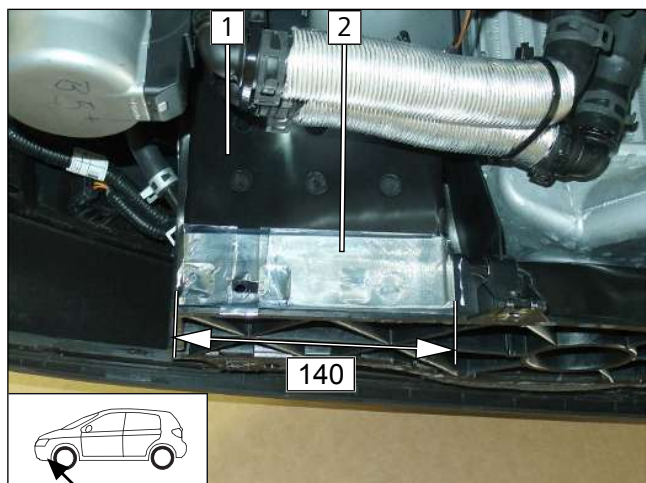

- 1 Radiator cross member
- 2 Heat protection film

Fig. 127

Mounting exhaust silencer

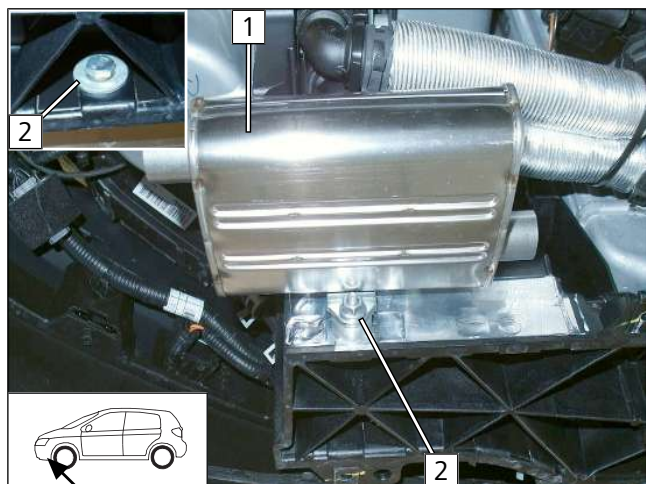

- 1 Exhaust silencer
- 2 M6x30 bolt, large diameter washer, hole, distance washer (10), perforated bracket, flanged nut

Fig. 128

Mounting exhaust pipe a1



- 1 Hose clamp
- 2 Exhaust silencer

Fig. 129



Mounting exhaust pipe **a2**

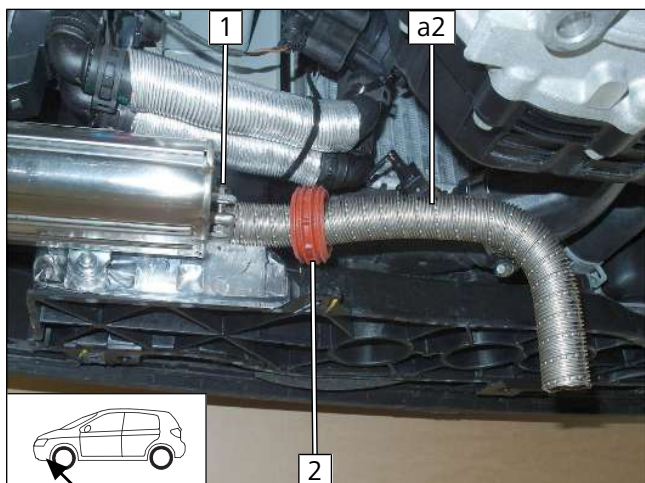

Fig. 130

- 1 Hose clamp
- 2 Slide on spacer bracket

Aligning exhaust pipe



Fig. 131



Ensure sufficient distance from neighbouring components, correct if necessary.



13.2 Mounting exhaust end fastener

Work step E1

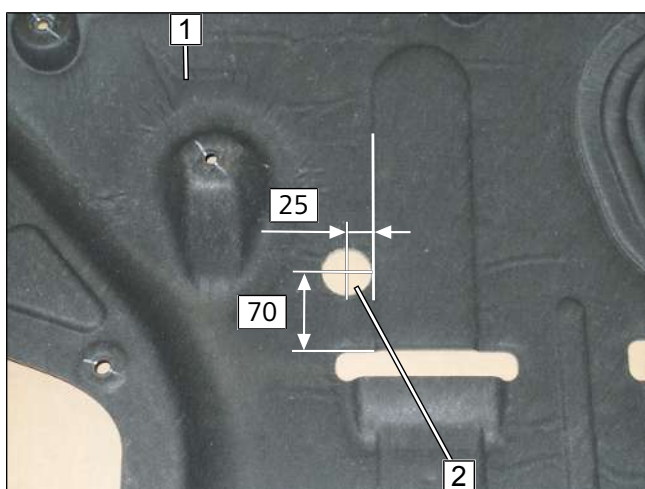

Fig. 132



Observe the EFIX installation instructions.

► Drill hole in underbody protection.

- 1 Underbody protection
- 2 Copy hole pattern, hole



Work step E3

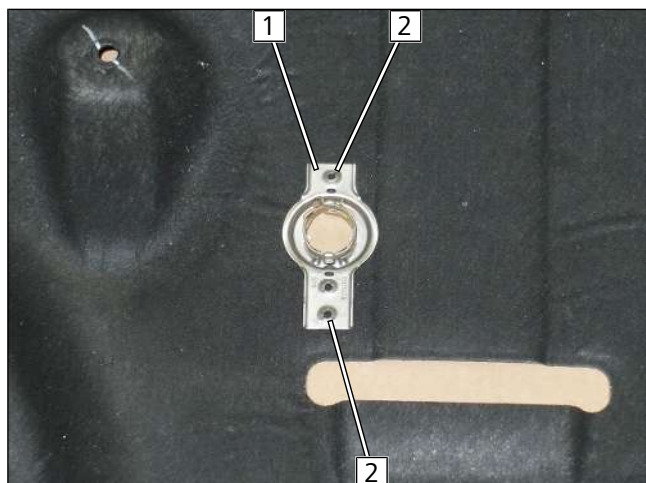

Fig. 133

► Copy hole pattern.

- 1 EFIX
- 2 Hole pattern

Work step E4

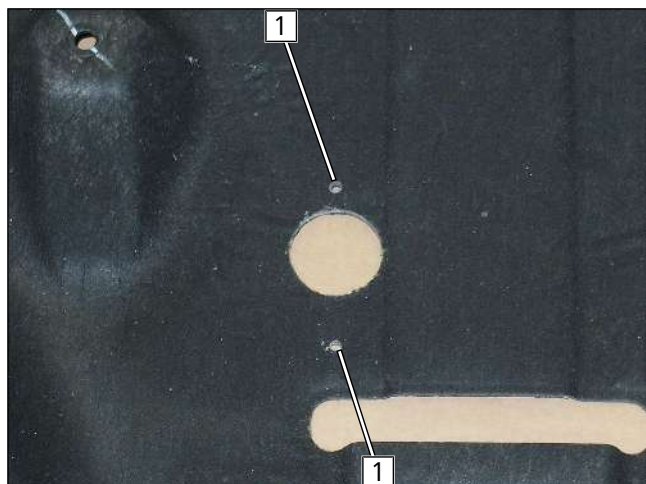

Fig. 134

► Drill holes in underride protection.

- 1 Hole

Work step E5

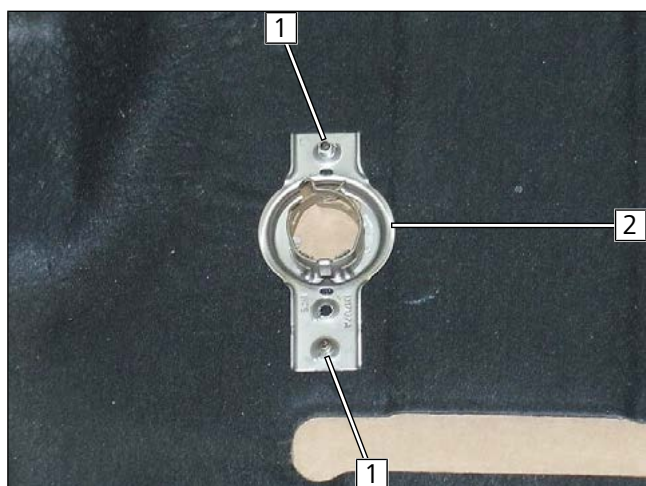

Fig. 135

► Mount exhaust end fastener.

- 1 5x13 self-tapping screw
- 2 EFIX



Work steps E6-E8

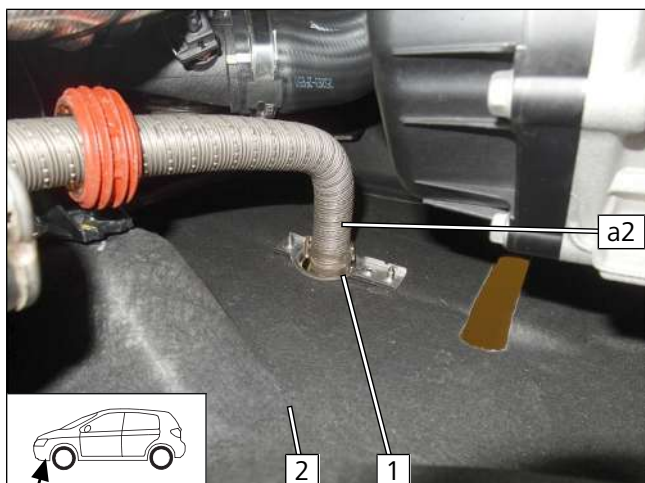

► Mount exhaust pipe **a2**.

- 1** EFIX
- 2** Underride protection

Fig. 136



14 Final work in engine compartment

Aligning black (sw) rubber isolator

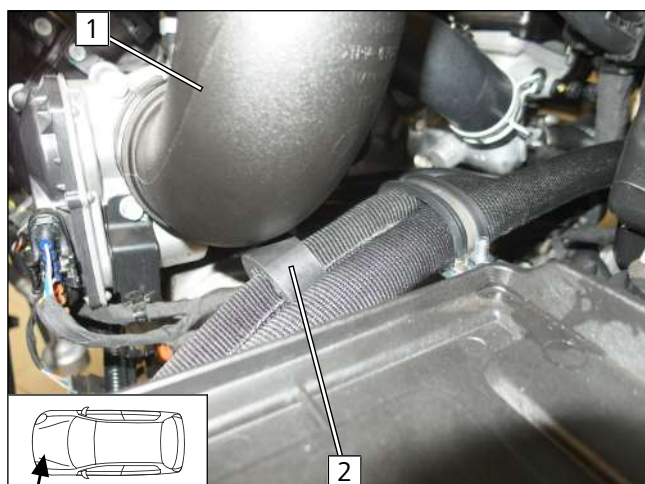

Fig. 137



97kW only



Danger of damage to components

► Ensure sufficient distance from neighbouring components, correct if necessary.

► Mount charge-air tube **1** and align black (sw) rubber isolator **2**.

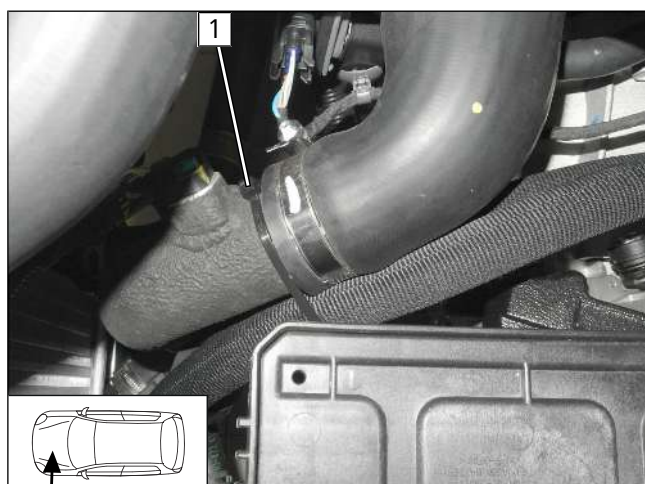

Fig. 138



130kW SG only



Danger of damage to components

► Ensure sufficient distance from neighbouring components, correct if necessary.

► Fasten hoses **(A)** and **(F)** to charge-air tube using cable tie **1**.



15 Electrical system of passenger compartment

15.1 Electrical system preparation

Preparing / assigning wires

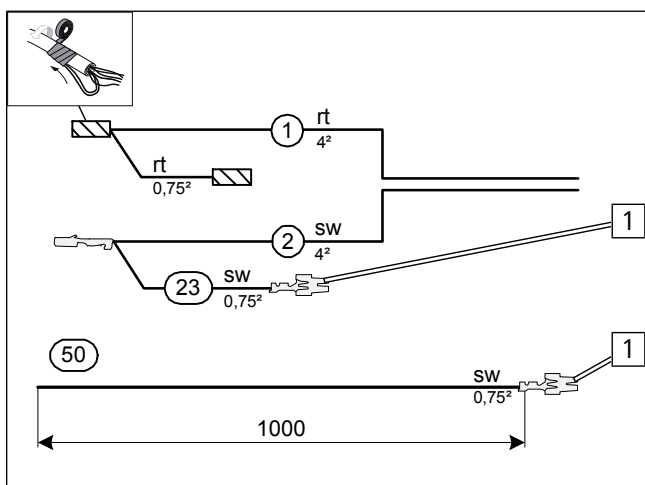

Fig. 139



Wire sections retain their numbering in the entire document.

- 1 Flat spring contact
- 1 Red (rt) wire of fan wiring harness
- 2 Black (sw) wire of fan wiring harness
- 50 Black (sw) wire for additional line

Connecting wires to RSH

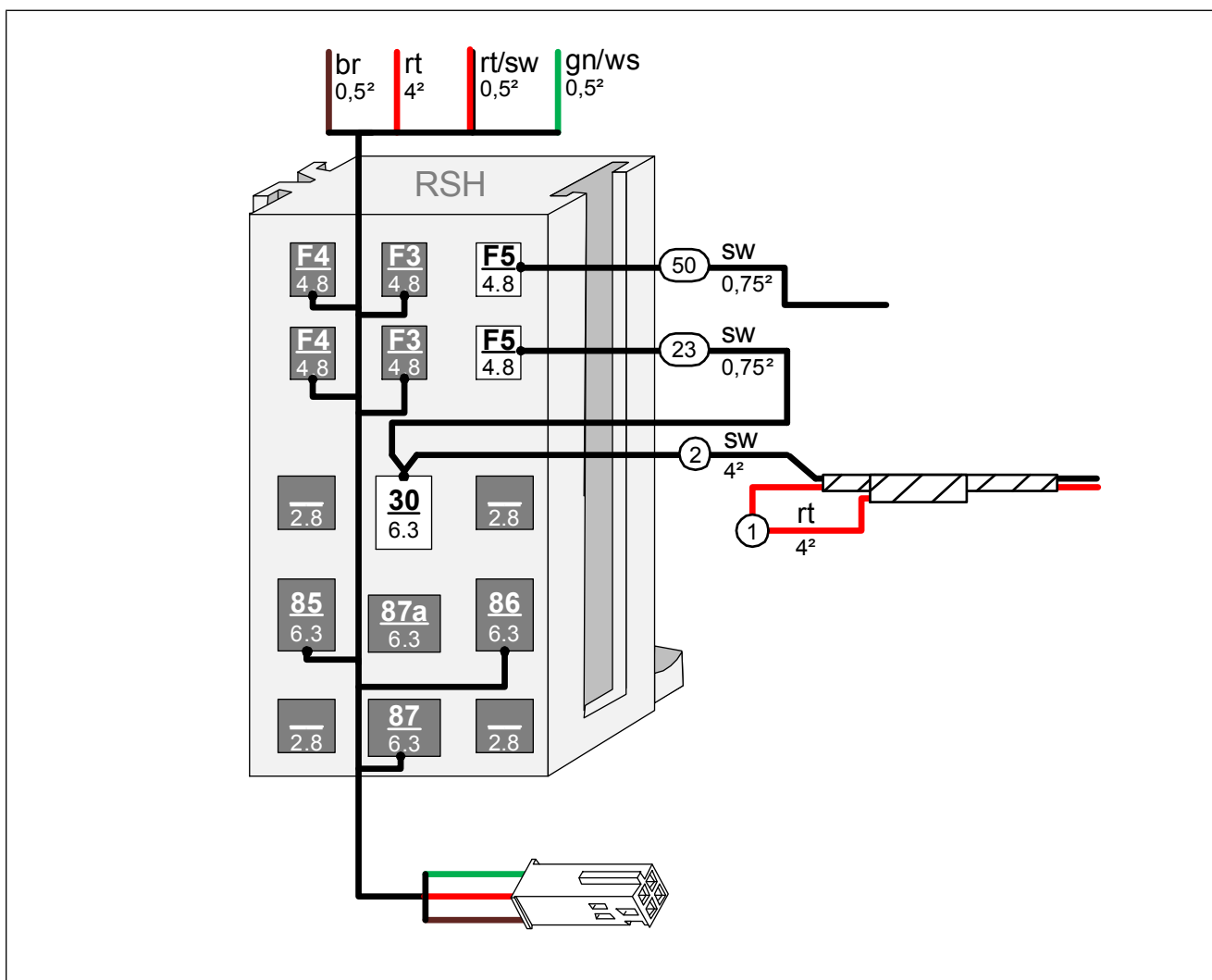

Fig. 140



Premounting RSH

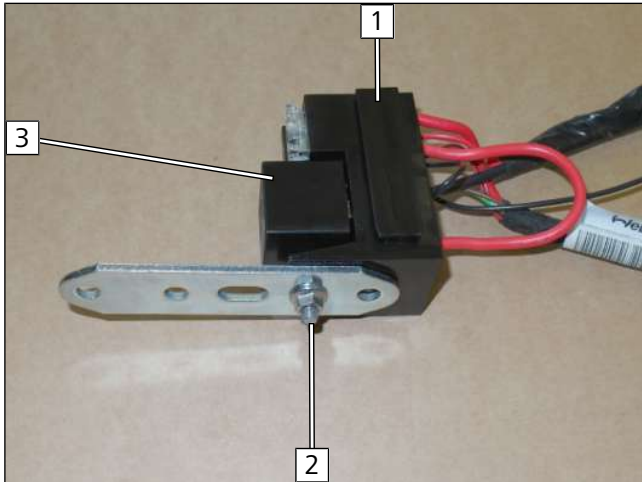

Fig. 141

- 1 RSH
- 2 Mount M5x16 bolt, large diameter washer, RSH, perforated bracket, large diameter washer, nut loosely
- 3 Relay K1

15.2 A/C control panel dismantling instructions for Hyundai Tucson

Detaching switch unit



Fig. 142

- 1 Switch unit
- Attachment points

Disconnecting switch unit

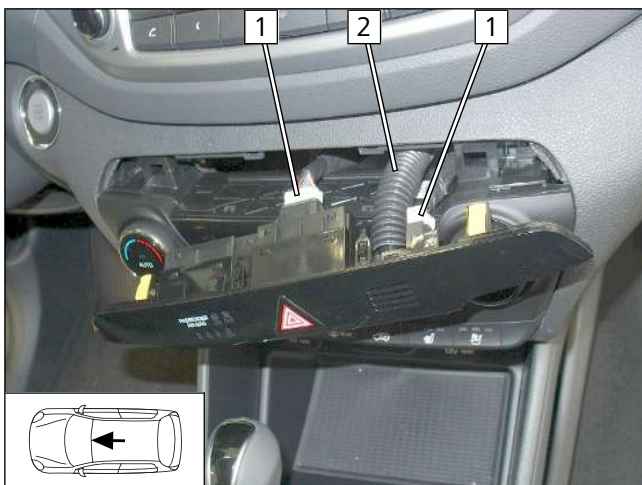

Fig. 143

- 1 Pull off original vehicle connector
- 2 Pull off original vehicle hose



Removing bolts and detaching A/C control panel

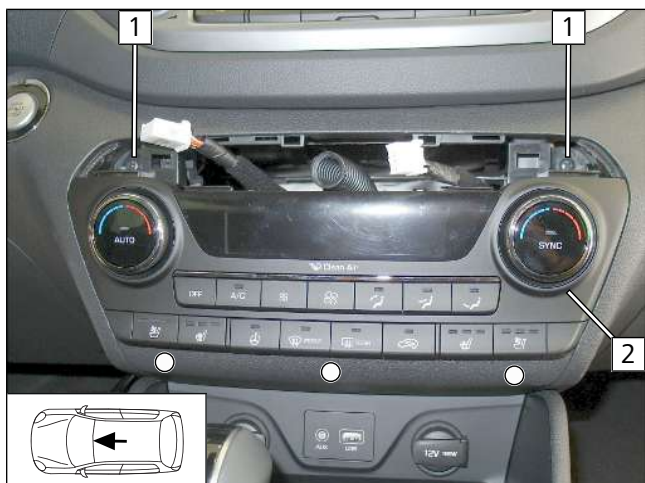

Fig. 144

- 1 Original vehicle bolt
- 2 A/C control panel
- Attachment points

15.3 A/C control panel dismantling instructions for Kia Sportage

Detaching centre console trim

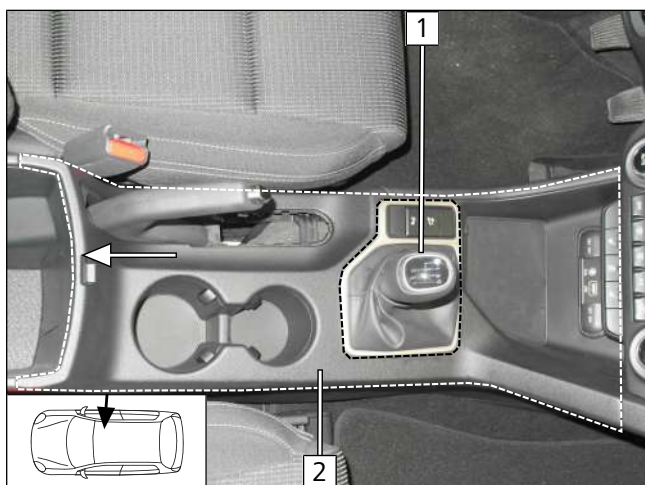

Fig. 145

- 1 Gear knob with trim
- 2 Centre console trim

Dismantling instrument panel trim

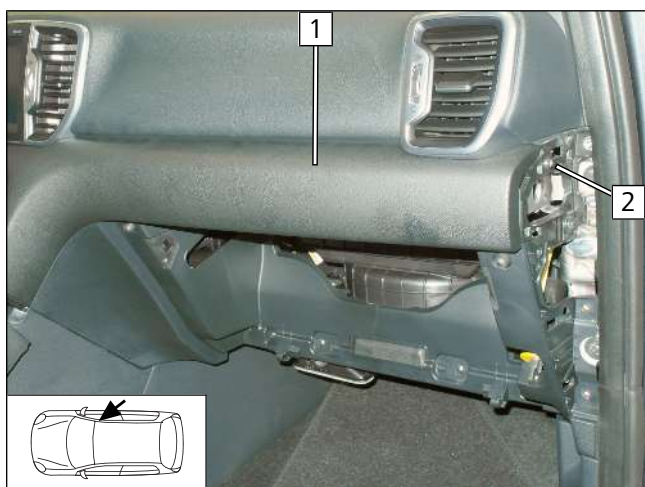
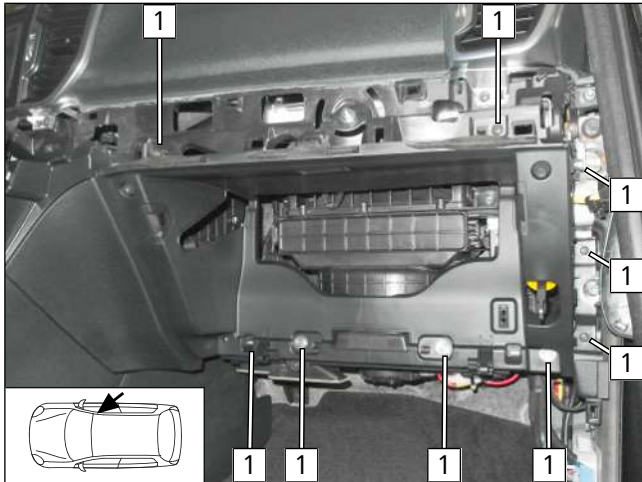

Fig. 146

- ▶ Remove cross-head screw 2 and pull off instrument panel trim 1.



Dismantling glove box, detaching glove box bracket



1 Original vehicle bolt

Fig. 147

Removing the A/C control panel

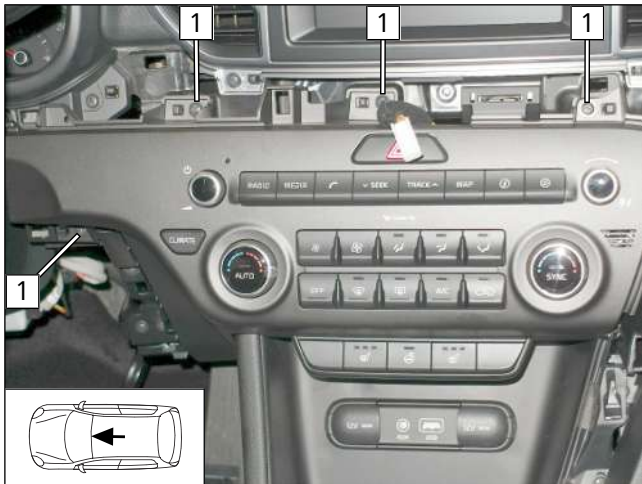

1 Original vehicle bolt

Fig. 148



15.4 Wiring diagram

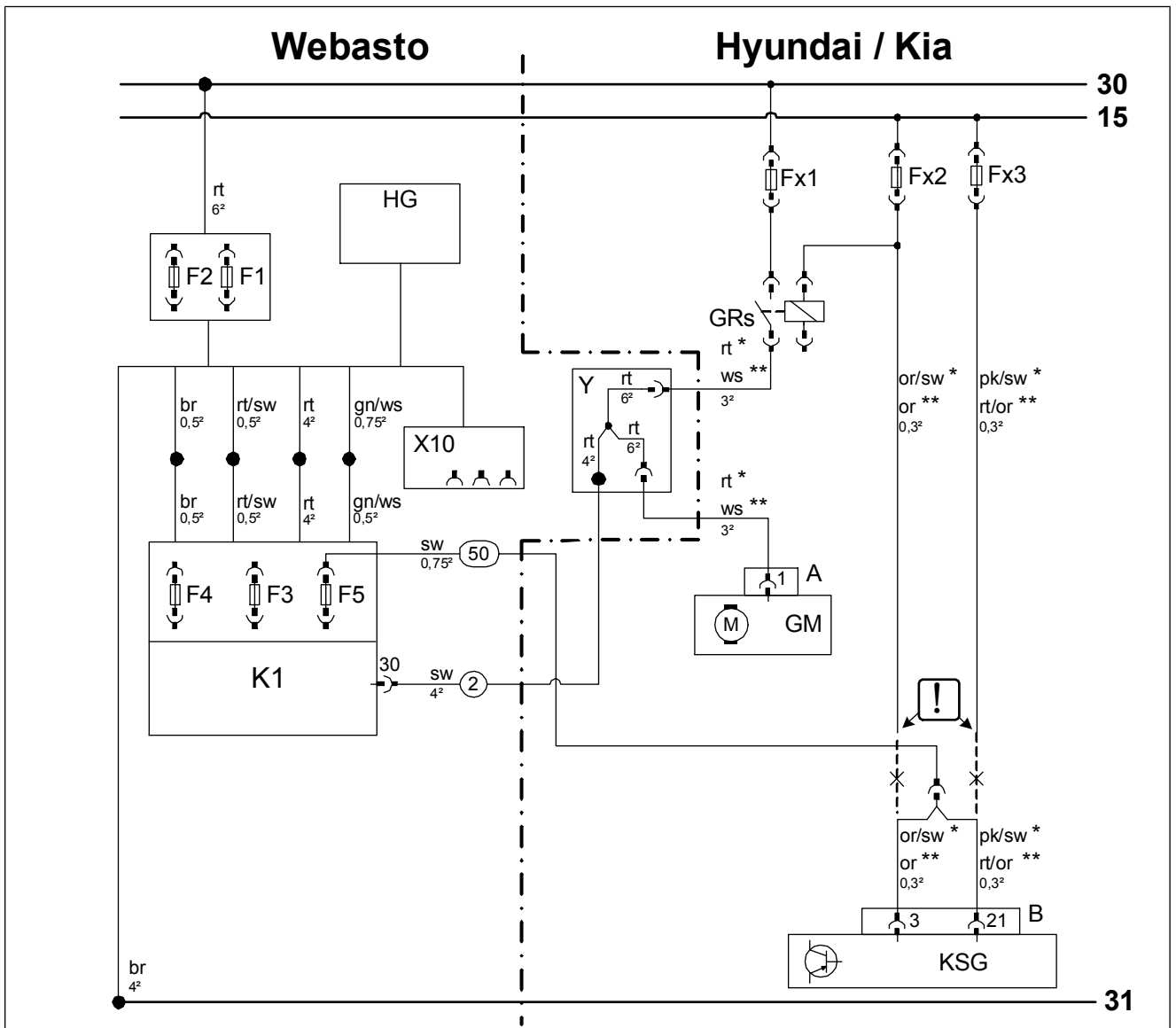

Fig. 149



Legend to wiring diagram



The vehicle connector and component designations are freely chosen by Webasto.
Cable colours may vary.

Vehicle components		Symbols	
Abbreviation	Component	Abbreviation	Designation
Fx1	Fuse	X	Cutting point
Fx2	Fuse		insulate and tie back
Fx3	Fuse		
GRs	Fan relay	*	Hyundai Tucson
GM	Fan motor	**	Kia Sportage
A	2-pin GM connector		
KSG	Air-conditioning control unit		
B	40-pin KSG connector		

Webasto components		Cable colours	
Abbreviation	Component	Abbreviation	Colour
A	Male plug for CLR module wiring harness	bg	beige
B	Female plug for CLR module wiring harness	bl	blue
C	Male plug for adapter wiring harness	br	brown
D	Female plug for adapter wiring harness	dbl	dark blue
E	Male plug for Plug&Play wiring harness	dgn	dark green
F	Female plug for Plug&Play wiring harness	ge	yellow
CCL GW	CAN CAN LIN Gateway	gn	green
CL GW	CAN LIN Gateway	gr	grey
CLR	Cold start module	hbl	light blue
D1	Diode	hgn	light green
D2	Diode group	la	salmon
F0	Additional fuse for power supply	or	orange
F1	Heater main fuse	pk	pink
F2	Passenger compartment fan controller main fuse	rt	red
F3	Control element fuse	sw	black
F4	Fan controller fuse	vi	violet
F5	Additional fuse	ws	white
HG	Heater TT-Evo		
K1	Relay K1		
K2	Relay K2		
K3	Relay K3		
LIN GW	LIN Gateway		
PWM GW	Pulse width modulator gateway		
RSH	Relay and fuse holder of passenger compartment		
RTD	Temperature sensor		
X10	Female plug for control element		
Y	Power adapter		



15.5 Fan controller

Mounting RSH

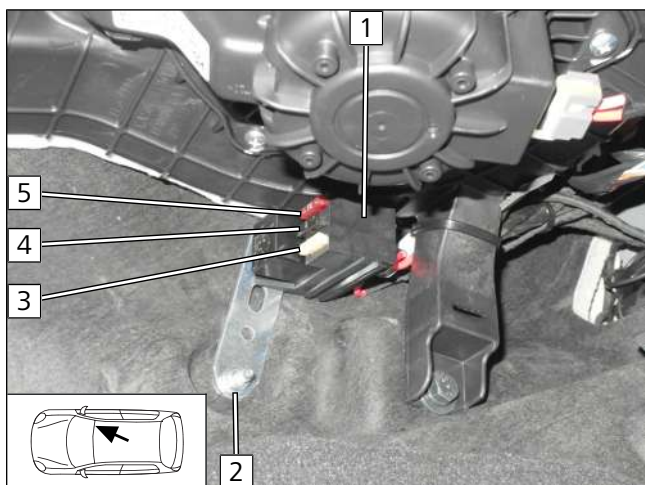

Fig. 150



The system wiring diagram is the basis to make the following electrical connections and for the corresponding cable colours.

- 1 RSH
- 2 Original vehicle stud bolt, perforated bracket, M6 flanged nut
- 3 25A fuse F4
- 4 1A fuse F3
- 5 7.5A fuse F5

Connecting same colour wires of wiring harnesses

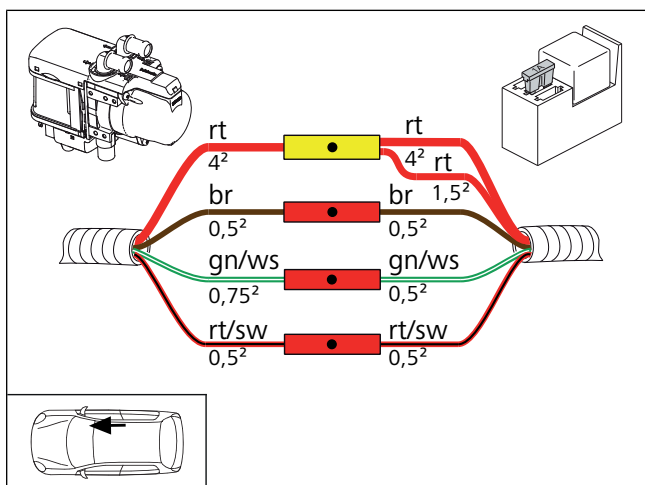

Fig. 151

Fan motor connection

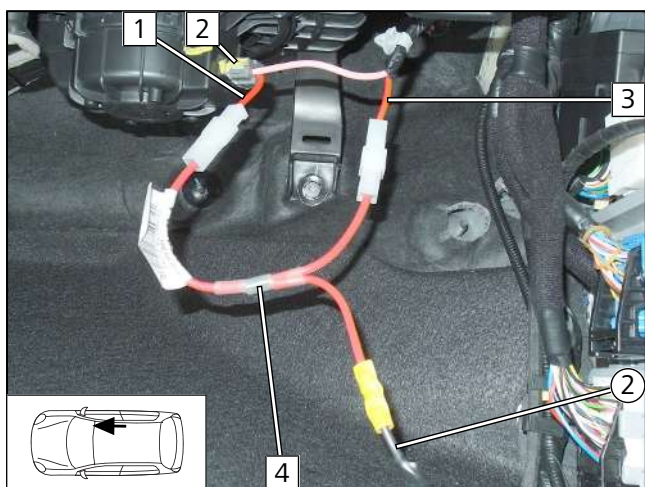

Fig. 152

- 1 Wire of connector A, pin 1
- 2 2-pin connector A of GM
- 3 Wire of original vehicle fan relay
- 4 Y power adapter
- 2 Black (sw) wire of K1/30 fan wiring harness



Disconnecting connector

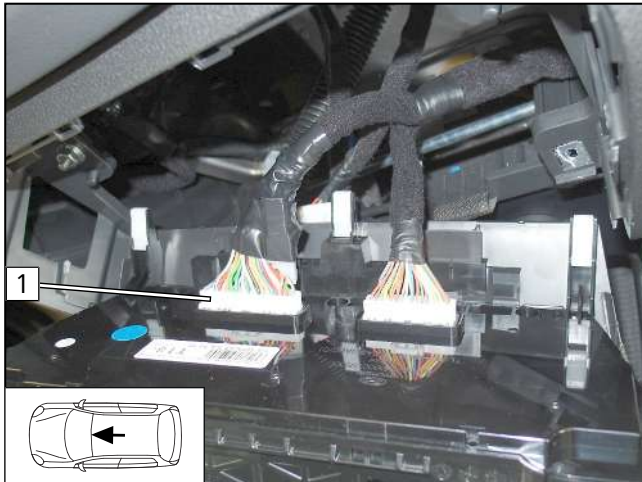

Fig. 153

- 1 40-pin connector B

View of connector B

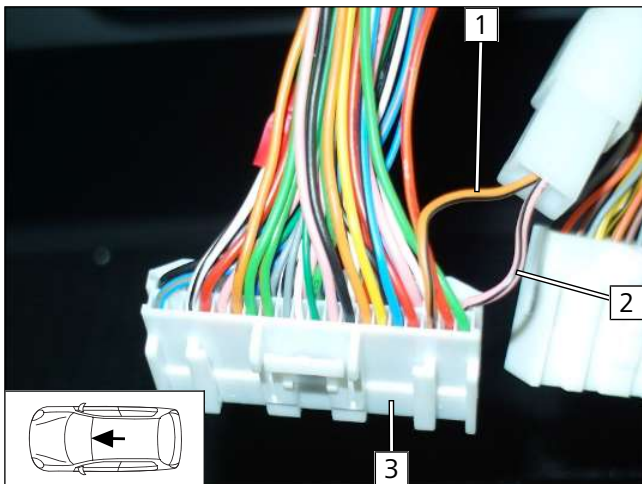

Fig. 154

- 1 Wire, pin 3
- 2 Wire, pin 21
- 3 40-pin KSG connector B

Connecting KSG

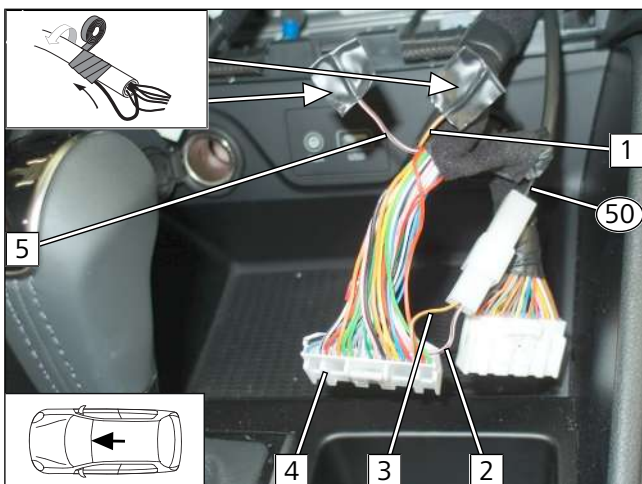

Fig. 155

- 1 Wire of fuse Fx2
- 2 Wire of 40-pin connector B, pin 21
- 3 Wire of 40-pin connector B, pin 3
- 4 40-pin KSG connector B
- 5 Wire of fuse Fx3
- 50 Black (sw) wire of fuse F5



16 Electrical system of control elements

16.1 MultiControl CAR option

Mounting MultiControl CAR

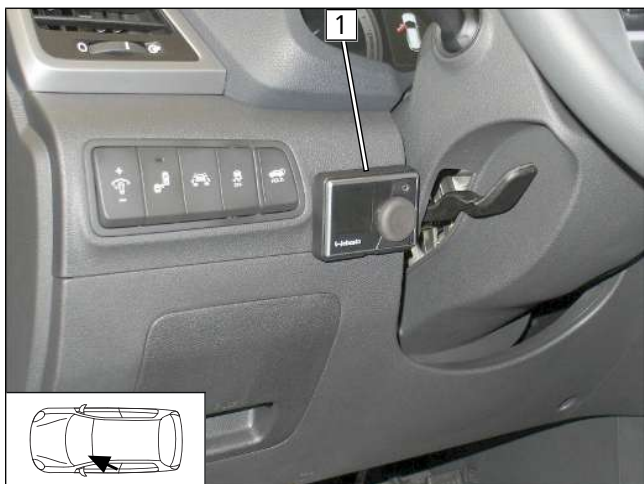

Fig. 156



Observe the MultiControl CAR installation documentation.

- 1 Installation frame

16.2 Telestart option

Preparing receiver

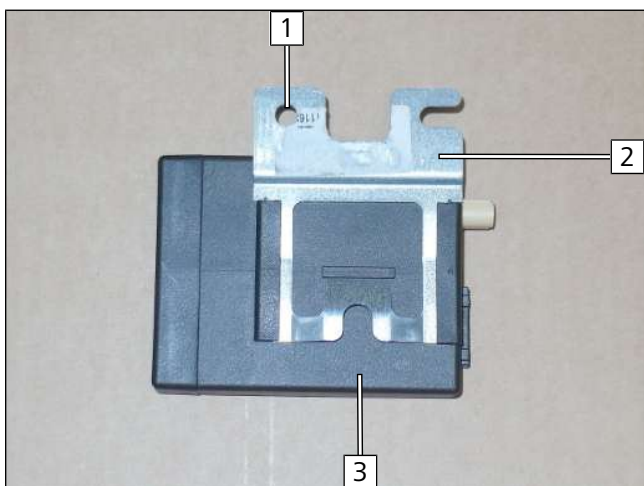

Fig. 157



Observe the Telestart installation documentation.

- 1 Drill out hole to $\text{Ø}8.5$
- 2 Bracket
- 3 Receiver

Mounting receiver

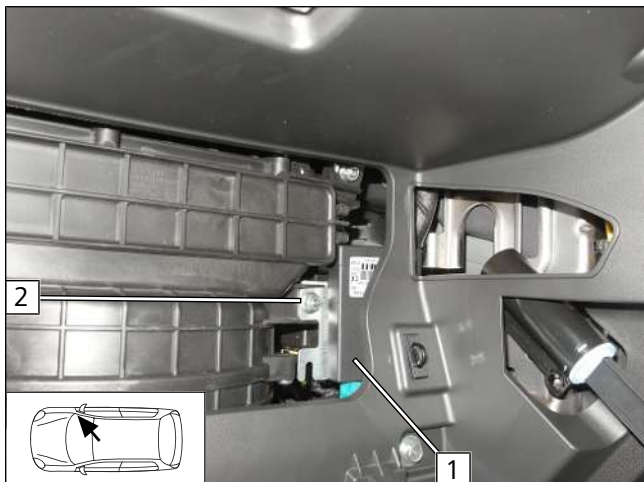

Fig. 158

- 1 Receiver
- 2 Original vehicle nut, receiver bracket



Mounting temperature sensor, only in case of T100 HTM

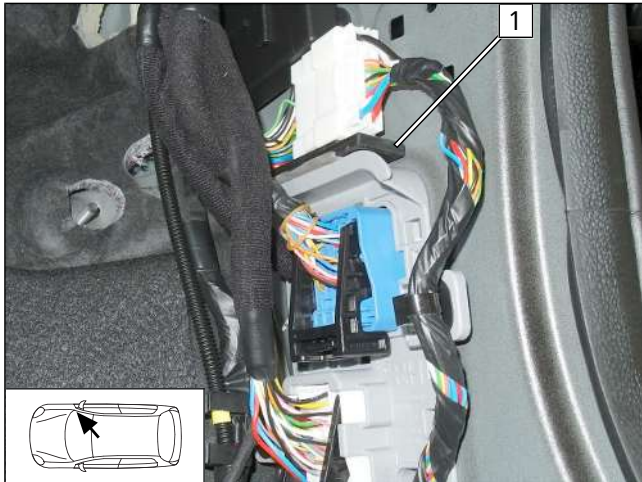

Fig. 159

- ▶ Fasten temperature sensor **1** using double-sided adhesive tape.

Mounting aerial

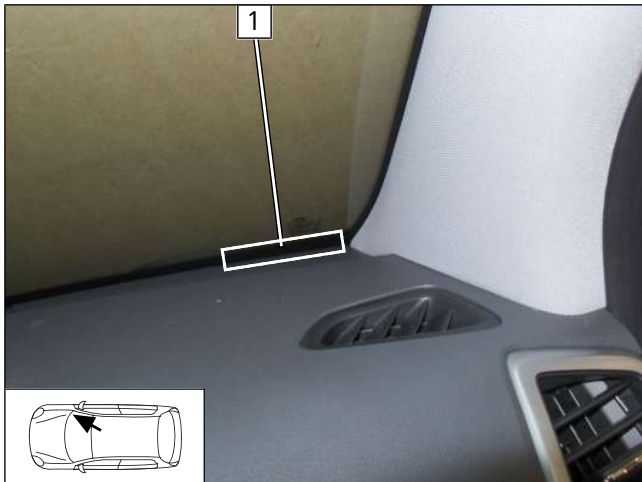

Fig. 160

- 1** Aerial

16.3 ThermoCall option

Mounting receiver

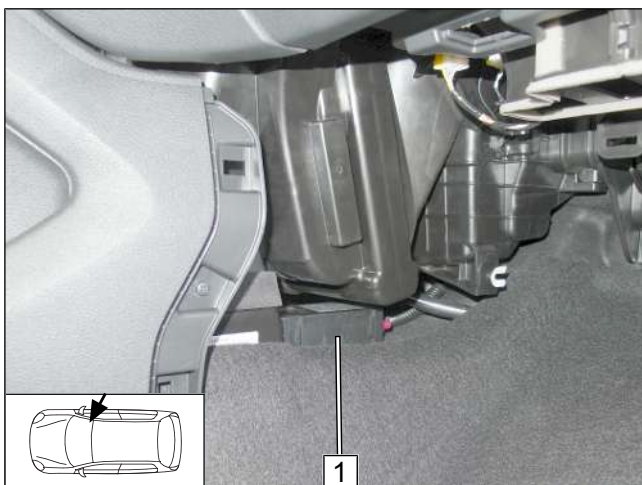
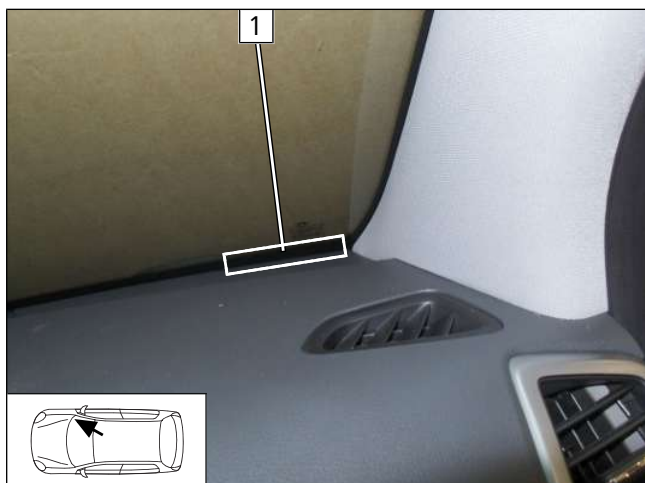

Fig. 161

- ▶ Fasten receiver **1** using double-sided adhesive tape.



Mounting aerial (optional)



1 Aerial

Fig. 162



17 Final Work



Further information can be found in the vehicle manufacturer's technical documentation.

- ▶ Mount removed parts in reverse order.



▶ Check all hoses, clamps and all electrical connections for firm seating.

▶ Insulate and tie back loose lines

▶ Spray heater and electrical components with anti-corrosion wax (Tectyl 100K).

▶ Connect the battery.



Only use manufacturer-approved coolant.

- ▶ Fill and bleed the coolant circuit according to the vehicle manufacturer's specifications.



Further information can be found in the general installation and operating instructions of the Webasto components.

▶ Program MultiControl CAR, teach Telestart transmitter

▶ Make settings on A/C control panel according to the 'Operating Instructions'.

▶ Initial operation and functional test

▶ Affix 'Switch off parking heater before refueling' caution label in area of filler neck

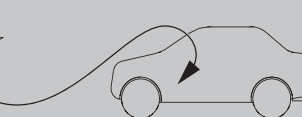
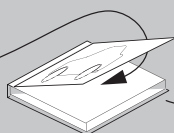
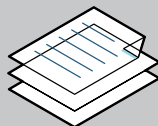

These are the original instructions. The German language is binding.
You can request your language if it is missing. The telephone number of each country can be found in the Webasto service centre leaflet or the website of the respective Webasto representative of your country.

Ident No. 1327063A_EN • 08/19 • Errors and omissions excepted • © Webasto Thermo & Comfort SE • 2019

Webasto Thermo & Comfort SE
Postfach 1410
82199 Gilching
Germany

Company address:
Friedrichshafener Str. 9
82205 Gilching
Germany

Technical Extranet: <https://dealers.webasto.com>



WWW.WEBASTO.COM



18 FuelFix template

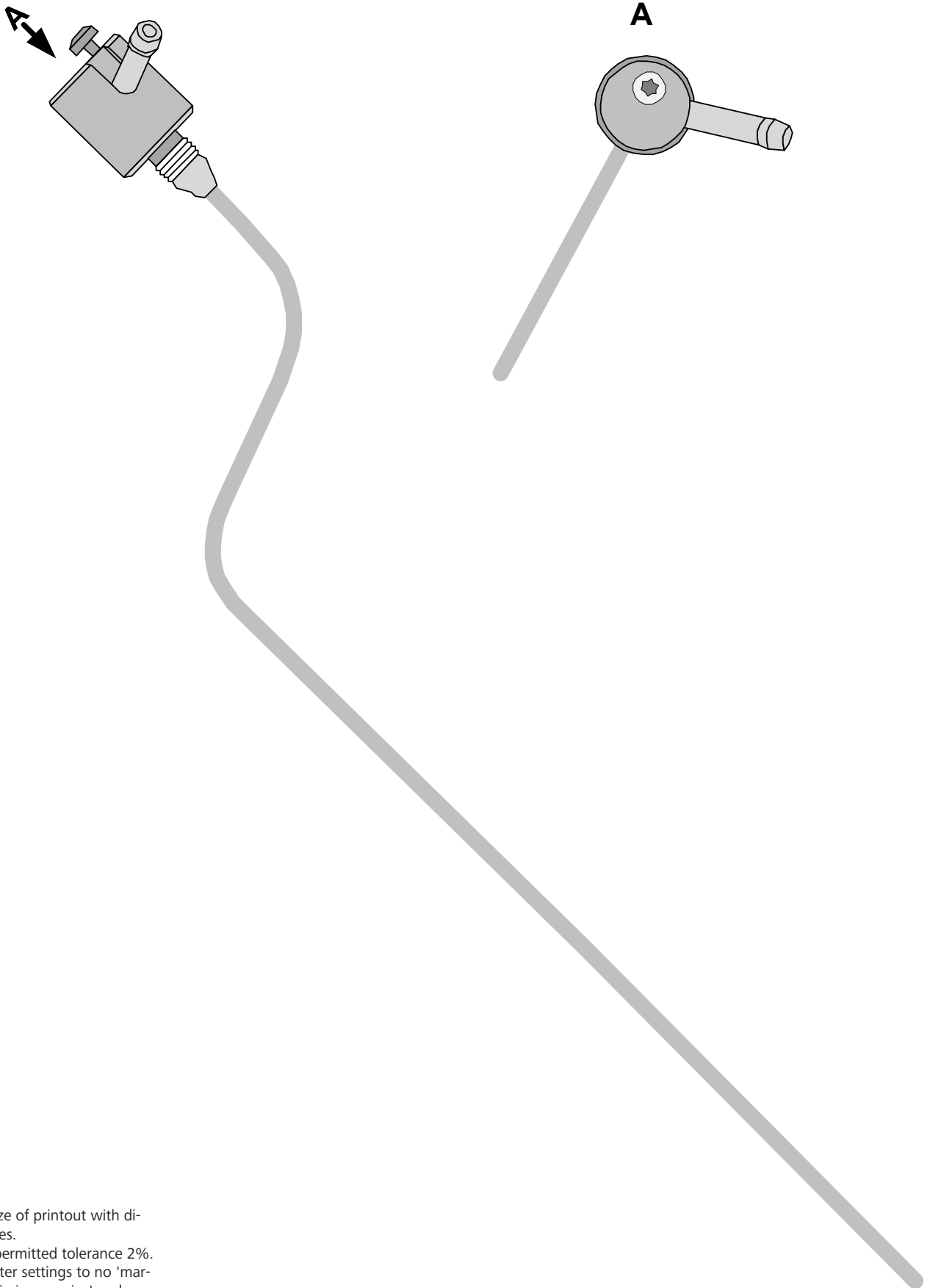

Scale 1:1
Compare size of printout with dimension lines.
Maximum permitted tolerance 2%.
Set the printer settings to no 'margin' or 'minimise margins' and 100% of the normal size.

19 Operating instructions for automatic air-conditioning of Hyundai Tucson



Information regarding the heating time:

We recommend matching the heating time to the driving time (heating time = driving time)

Example: for a driving time of approx. 20 min. (in one direction), we recommend not exceeding a switch-on time of 20 min.



Vehicles with passenger compartment monitoring:

Further information can be found in the vehicle operating instructions.

- ▶ Deactivate passenger compartment monitoring for the heating operation



Note for parking heater function

Your vehicle is equipped with a passenger compartment preheating unit. There is **no** engine pre-heating.

19.1 A/C control panel settings

Automatic A/C control panel



Fig. 163



Before parking the vehicle, make the following settings:

- 1 Temperature on both sides to 'HI'
- 2 Air outlet to windscreen
- 3 Set fan to level '2' to '3'

19.2 Installation location of fuses

Fuses in engine compartment

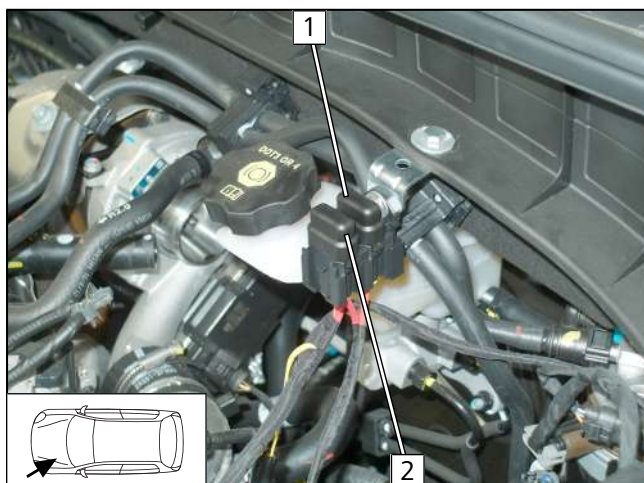
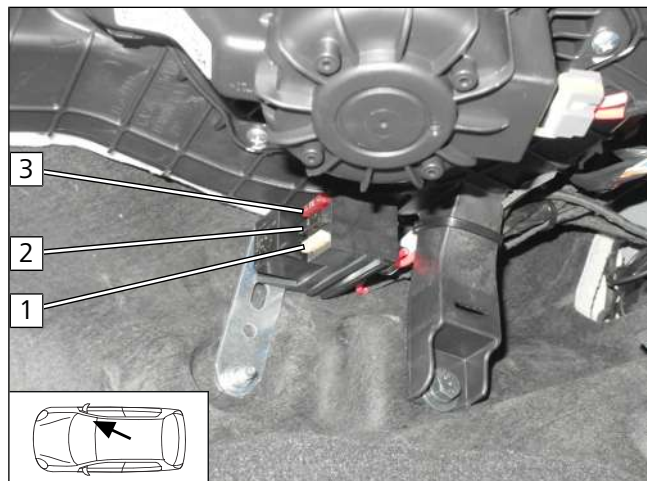

Fig. 164

- 1 F2 - 30A main fuse of passenger compartment
- 2 F1 - 20A heater fuse

Fuses in passenger compartment



- 1 F4 - 25A fan fuse
- 2 F3 - 1A control element fuse
- 3 F5 - 7.5A A/C control panel fuse

Fig. 165

20 Operating instructions for automatic air-conditioning of Kia Sportage



Information regarding the heating time:

We recommend matching the heating time to the driving time (heating time = driving time)

Example: for a driving time of approx. 20 min. (in one direction), we recommend not exceeding a switch-on time of 20 min.



Vehicles with passenger compartment monitoring:

Further information can be found in the vehicle operating instructions.

► Deactivate passenger compartment monitoring for the heating operation



Note for parking heater function

Your vehicle is equipped with a passenger compartment preheating unit. There is **no** engine pre-heating.

20.1 A/C control panel settings

Automatic A/C control panel

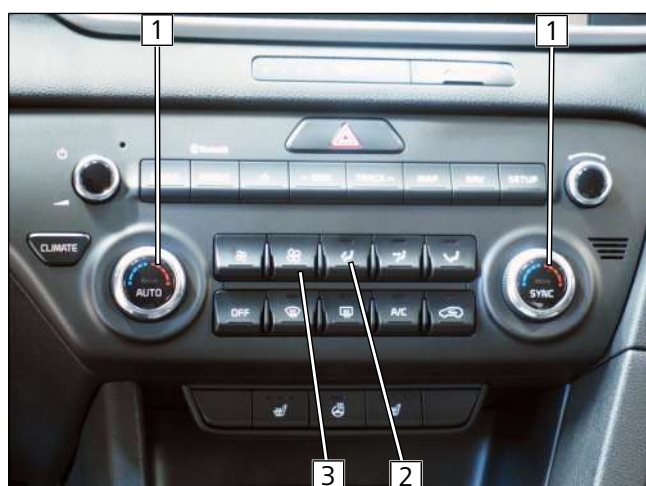

Fig. 166



Before parking the vehicle, make the following settings:

- 1 Temperature on both sides to 'HI'
- 2 Air outlet to windscreen
- 3 Set fan to level '2' to '3'

20.2 Installation location of fuses

Fuses in engine compartment

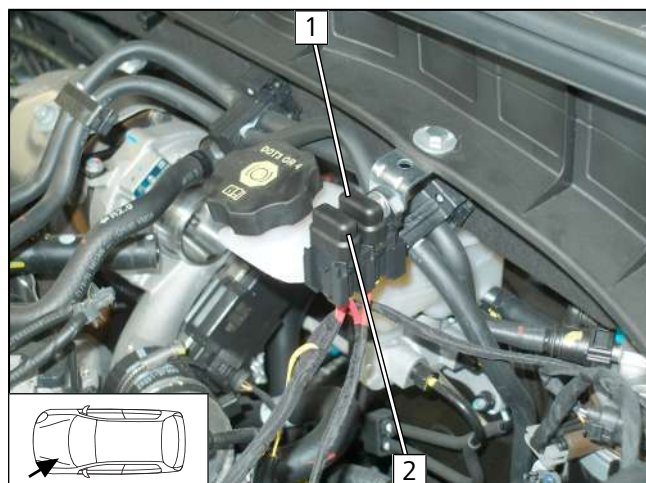
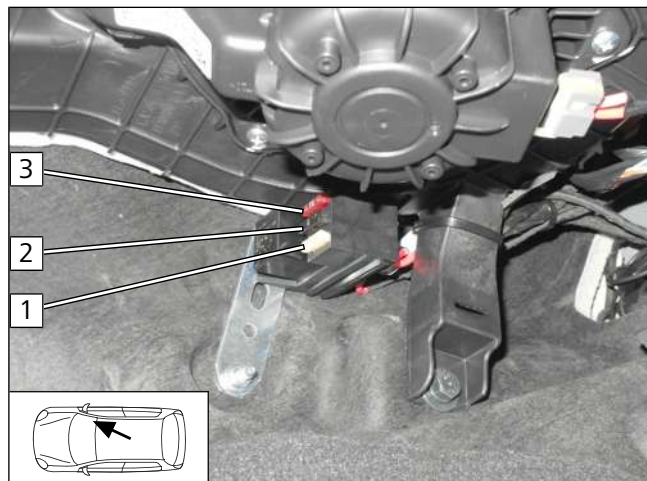

Fig. 167

- 1 F2 - 30A main fuse of passenger compartment
- 2 F1 - 20A heater fuse

Fuses in passenger compartment



- 1 F4 - 25A fan fuse
- 2 F3 - 1A control element fuse
- 3 F5 - 7.5A A/C control panel fuse

Fig. 168