

# K Installation Instructions

for Thermo Top Evo water heater

'Inline' coolant circuit with engine preheating

Hyundai Tucson / Kia Sportage

Left-hand drive vehicle

Manufacturer	Model	Type	Model year	EG-BE-No. / ABE
Hyundai	Tucson	TLE	from 2019	e11* 2007/46* 2724*...

Motorisation	Fuel	Emission standard	Transmission type	Output [kW]	Displacement [cm <sup>3</sup> ]	Engine code
1.6 CRDi	Diesel	Euro 6d temp	AG	100	1598	D4FE
2.0 CRDi	Diesel	Euro 6d temp	AG	136	1995	D4HA

Manufacturer	Model	Type	Model year	EG-BE-No. / ABE
Kia	Sportage	QLE	from 2019	e11 * 2007 / 46 * 3144 *

Motorisation	Fuel	Emission standard	Transmission type	Output [kW]	Displacement [cm <sup>3</sup> ]	Engine code
1.6 CRDi	Diesel	Euro 6d temp	AG	100	1598	D4FE
2.0 CRDi	Diesel	Euro 6d temp	AG	136	1995	D4HA

Validity	Equipment variants	Model	
		Tucson	Sportage
Verified equipment variants	2 zone automatic air-conditioning	x	x
	Halogen main headlights	x	x
	Halogen front fog lights	x	x
	LED daytime running lights	x	x
	LED main headlights	x	x
	Automatic Start-Stop system	x	x
	Keyless Go	x	x
	Start button	x	x
Unverified equipment variants	Manual air-conditioning	x	x
	Full LED headlights with headlight washer system	x	x

---

<b>Total installation time</b>	<b>Note</b>
8.1 hours	

---

# Contents

<b>1</b>	<b>List of abbreviations</b>	<b>4</b>	<b>13</b>	<b>Exhaust</b>	<b>48</b>
<b>2</b>	<b>Installation notes</b>	<b>5</b>	13.1	Mounting exhaust pipe	48
2.1	Information on Validity	5	13.2	Mounting exhaust end fastener	50
2.2	Components used	5	<b>14</b>	<b>Electrical system of passenger compartment</b>	<b>53</b>
2.3	Information on Total Installation Time	5	14.1	Electrical system preparation	53
2.4	Installation recommendations	5	14.2	A/C control panel dismantling instructions for Hyundai Tucson	54
<b>3</b>	<b>About this document</b>	<b>6</b>	14.3	A/C control panel dismantling instructions for Kia Sportage	55
3.1	Purpose of the document	6	14.4	Wiring diagram	57
3.2	Warranty and liability	6	14.5	Fan controller	59
3.3	Safety	6	<b>15</b>	<b>Electrical system of control elements</b>	<b>61</b>
3.4	Using this document	7	15.1	MultiControl CAR option	61
<b>4</b>	<b>Technical Information</b>	<b>8</b>	15.2	Telestart option	61
<b>5</b>	<b>Preparing measures</b>	<b>9</b>	15.3	ThermoCall option	62
5.1	Vehicle preparation	9	<b>16</b>	<b>Final Work</b>	<b>64</b>
5.2	Heater preparation	9	<b>17</b>	<b>FuelFix template</b>	<b>67</b>
<b>6</b>	<b>Installation overview</b>	<b>10</b>	<b>18</b>	<b>Operating instructions for automatic air-conditioning of Hyundai Tucson</b>	<b>69</b>
<b>7</b>	<b>Electrical system of engine compartment</b>	<b>11</b>	18.1	A/C control panel settings	69
<b>8</b>	<b>Mechanical system</b>	<b>13</b>	18.2	Installation location of fuses	69
8.1	Preparing installation location	13	<b>19</b>	<b>Operating instructions for automatic air-conditioning of Kia Sportage</b>	<b>71</b>
8.2	Premounting heater	17	19.1	A/C control panel settings	71
8.3	Heater mounting	19	19.2	Installation location of fuses	71
<b>9</b>	<b>Fuel</b>	<b>21</b>			
9.1	Routing fuel line	21			
9.2	Installing FuelFix	25			
<b>10</b>	<b>Combustion air</b>	<b>30</b>			
<b>11</b>	<b>Coolant for 1.6 CRDi</b>	<b>31</b>			
11.1	Hose routing diagram	31			
11.2	Preliminary Work	32			
11.3	Coolant circuit installation	35			
<b>12</b>	<b>Coolant for 2.0 CRDi</b>	<b>40</b>			
12.1	Hose routing diagram	40			
12.2	Preliminary Work	41			
12.3	Coolant circuit installation	43			

---

# 1 List of abbreviations

AG	Automatic transmission
DP	Fuel pump
EFIX	Exhaust end fastener
FF	FuelFix (tank extracting device)
Fig.	Figure
HG	Heater
MCC	MultiControl (control element)
RSH	Relay and fuse holder of passenger compartment
SH2	Engine compartment fuse holder for F1/F2
UP	Coolant pump

---

## 2 Installation notes

### 2.1 Information on Validity

This installation documentation applies to vehicles listed on page 1, assuming technical modifications to the vehicle do not affect installation, any liability claims excluded. Depending on the vehicle version and equipment, modifications may be necessary during installation with respect to this installation documentation. Vehicle and engine types, equipment variants and other specifications not listed in this installation documentation have not been tested. However, installation according to this installation documentation may be possible.

### 2.2 Components used

Designation	Order number
Basic delivery scope of Thermo Top Evo	In accordance with price list
Installation kit for Hyundai Tucson/Kia Sportage diesel MY 2019 TT-Evo	1327110A
In case of MultiControl CAR installation – installation frame for MultiControl	9030077_
In case of control element as well as Telestart indicator lamp in consultation with end customer	In accordance with price list

### 2.3 Information on Total Installation Time

The total installation time includes the time needed for mounting and demounting the vehicle-specific components, the heater specific installation time and all other times required for the system integration and initial start-up of the heater.

The total installation time may vary for vehicle equipment other than provided.

### 2.4 Installation recommendations

Arrange for the vehicle to be delivered with the tank only about ¼ full.

For the MultiControl CAR option, the recommended installation locations for the Telestart or ThermoCall push button should be confirmed with the end customer.

Depending on the space required and the vehicle manufacturer's instructions, we recommend the use of a vehicle battery with a higher electrical capacity.

---

## 3 About this document

### 3.1 Purpose of the document

This installation documentation is part of the product and contains all the information required to ensure professional vehicle specific installation of the:

Thermo Top Evo heater
-----------------------

### 3.2 Warranty and liability

Webasto shall assume no liability for defects, damage and injuries resulting from a failure to observe the installation, repair and operating instructions of the information contained in them.

This liability exclusion particularly applies to improper installations and repairs by untrained persons or in the case of a failure to use genuine spare parts.

The liability due to culpable disregard to life, limb or health and due to damage or injuries caused by a wilful or reckless breach of duty remain unaffected, as does the obligatory product liability.

Installation should be carried out according to the general, standard rules of technology. Unless specified otherwise, fasten hoses, lines and wiring harnesses to original vehicle lines and wiring harnesses using cable ties. Insulate loose wire ends and tie back. Connectors on electronic components must audibly snap into place during assembly.

Spray unfinished body areas, e.g. drilled holes, with anti-corrosion wax (Tectyl 100K).

Observe the instructions and guidelines of the respective vehicle manufacturer for demounting and mounting vehicle specific components.

The initial start-up is to be executed with the Webasto Thermo Test Diagnosis.

When installing a programmable control module (e.g. a PWM Gateway), the corresponding settings must be checked or adjusted.

#### 3.2.1 Statutory regulations governing installation

The Thermo Top Evo heater has been type-tested and approved in accordance with ECE-R 10 (EMC) and ECE-R 122 (heater). The regulations of these guidelines are binding in the scope of the Directive 70/156/EEC and/or 2007/46/EC (for new vehicle models from 29/04/2009) and should also be observed in countries in which there are no special regulations.

The heater is licensed in accordance with paragraph 19, section 3, No. 2b of the StVZO (German Road Traffic Licensing Authority).

### 3.3 Safety

#### Qualifications of installation personnel

The installation personnel must have the following qualifications:

- Successful completion of Webasto training
- Corresponding qualification for working on technical systems

#### Regulations and legal requirements

The regulations from the heater's general installation and operating instructions must be observed.

#### 3.3.1 Safety information on installation

##### Danger posed by live parts

- ▶ Prior to installation, disconnect the vehicle from the voltage supply.
- ▶ Make sure the electrical system is earthed correctly.
- ▶ Always comply with legal requirements.
- ▶ Observe data on type label.

##### Danger of fire and leaking toxic gases due to improper installation

- ▶ Vehicle parts in the vicinity of the heater must be protected against excessive heating by the following measures:
  - ⇒ Maintain minimum safety distances.
  - ⇒ Ensure adequate ventilation.
  - ⇒ Use fire-resistant materials or heat shields.

##### Danger due to sharp edges









- Lacerations
- Short circuit due to electrical wire damage
- ▶ Fit protectors on sharp edges.

### 3.4 Using this document

Before installing and operating the heater, read this installation documentation, the installation instructions of the heater, the operating instructions and supplementary sheets provided.

#### 3.4.1 Explanatory Notes on the Document

There is an identification mark near the respective work step to allow you to quickly allocate the other applicable documents to the Webasto components to be installed:

Generally valid Webasto documentation	
Vehicle-specific installation documentation	
Vehicle-specific installation documentation of the cold start kit	
Webasto Comfort A/C control	
Webasto Standard A/C control	
Tank extracting device (e.g. FuelFix)	
Exhaust end fastener (EFIX)	
Combustion air intake silencer	
Spacer bracket (ASH)	

#### 3.4.2 Use of symbols



#### DANGER

Type and source of the risk

Consequences: Failure to follow the instructions can result in death

► Actions to protect yourself against risks.



#### WARNING

Type and source of the risk

Consequences: Failure to follow the instructions can lead to serious or even fatal injuries

► Actions to protect yourself against risks.



#### CAUTION

Type and source of the risk

Consequences: Failure to follow the instructions can lead to minor injuries

► Actions to protect yourself against risks.



Type and source of the risk

Consequences: Failure to follow the instructions can lead to material damage

► Actions to protect yourself against risks.











Reference to the vehicle manufacturer's specific documents.

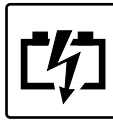

Note on a special technical feature

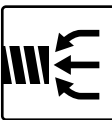
#### 3.4.3 Work step identification marks

The ongoing work step is indicated on the outside top corner of the page:

Mechanical system	Electrical system	High-voltage	Coolant
			
Combustion air	Fuel	Exhaust	Software
			

#### 3.4.4 Orientation aid

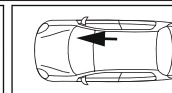

The arrow indicates the position on the vehicle and the viewing angle

#### 3.4.5 Use of highlighting

Highlight	Explanation
►	Necessary action
⇒	Result of an action
<b>1</b> / <b>12</b> / <b>a1</b>	Position numbers for the image descriptions
<b>①</b> / <b>⑫</b> / <b>Ⓐ</b>	Position numbers for the image descriptions for electrical wires and coolant hose sections

## 4 Technical Information

### Dimension specifications

- All dimensions specified in mm
- Perforated brackets and mounting angles are shown to scale
- Observe data regarding scale on the templates

### Tightening torque specifications

- Tightening torque values of 5x13 heater bolts and 5x11 heater stud bolts = 8Nm
- Tightening torque values of 5x15 retaining plate of water connection piece bolts = 7Nm
- 5x12 bolt tightening torque of 2-part heater bracket = 6Nm
- Tighten other bolt connections in accordance with manufacturer's instructions or in accordance with state-of-the-art-technology

### Temperature specification for heat shrink plastic tubings

- Fabric heat shrink tubing: shrink temperature max. 230°C
- Standard heat shrink plastic tubing: shrink temperature max. 300°C

### Necessary special tools

- Hose clamp pliers for auto-tightening hose clamps
- Hose clamp pliers for Clic hose clamps of type W
- Hose clamping pliers
- Hose cutter
- Automatic wire stripper 0.2 - 6 mm<sup>2</sup>
- Crimping pliers for cable lugs 0.5 – 10 mm<sup>2</sup>
- Crimping pliers for male connector 0.14 – 6 mm<sup>2</sup>
- Crimping pliers for connector 0.25 – 6 mm<sup>2</sup>
- Torque wrench for 2.0 - 10 Nm
- Deep-hole marker
- Metric thread-setter kit
- Webasto Thermo Test Diagnosis with current software



## 5 Preparing measures

### 5.1 Vehicle preparation



Further information can be found in the vehicle manufacturer's technical documentation.

Vehicle area	Components to be removed	Other applicable documents
General	<ul style="list-style-type: none"> <li>▶ Open the fuel tank cap</li> <li>▶ Ventilate the fuel tank</li> <li>▶ Close the fuel tank cap again</li> <li>▶ Depressurise the cooling system</li> </ul>	
Engine compartment and body	<ul style="list-style-type: none"> <li>▶ Front wheel on the driver's side</li> <li>▶ Front wheel well trim on the driver's side</li> <li>▶ Lower engine trim</li> <li>▶ Underbody trim on the driver's side</li> <li>▶ Drain the engine coolant</li> <li>▶ Plenum</li> <li>▶ Battery</li> <li>▶ Entire air filter housing</li> <li>▶ Battery carrier</li> </ul>	
Passenger compartment	<ul style="list-style-type: none"> <li>▶ Upper front footwell trim on the front passenger's side</li> <li>▶ Front entrance strip trim on the front passenger's side</li> <li>▶ Lower A-pillar trim on the front passenger's side</li> <li>▶ Centre console trim in the footwell on the front passenger's side</li> <li>▶ Side instrument panel trim on the driver's and front passenger's side (Kia Sportage only)</li> <li>▶ Lower instrument panel trim on the driver's side (Kia Sportage only)</li> <li>▶ Glove box (Kia Sportage only)</li> <li>▶ Instrument panel trim piece (Kia Sportage only)</li> <li>▶ A/C control panel (see dismantling instructions)</li> <li>▶ Rear bench seat (pay attention to the seat heating connectors)</li> <li>▶ Open the tank fitting service lid</li> </ul>	

### 5.2 Heater preparation

Engine compartment	<ul style="list-style-type: none"> <li>▶ Remove years that do not apply from the type and duplicate label</li> <li>▶ Attach the duplicate label (type label) in the appropriate place in the engine compartment</li> </ul>	
--------------------	--	--

## 6 Installation overview

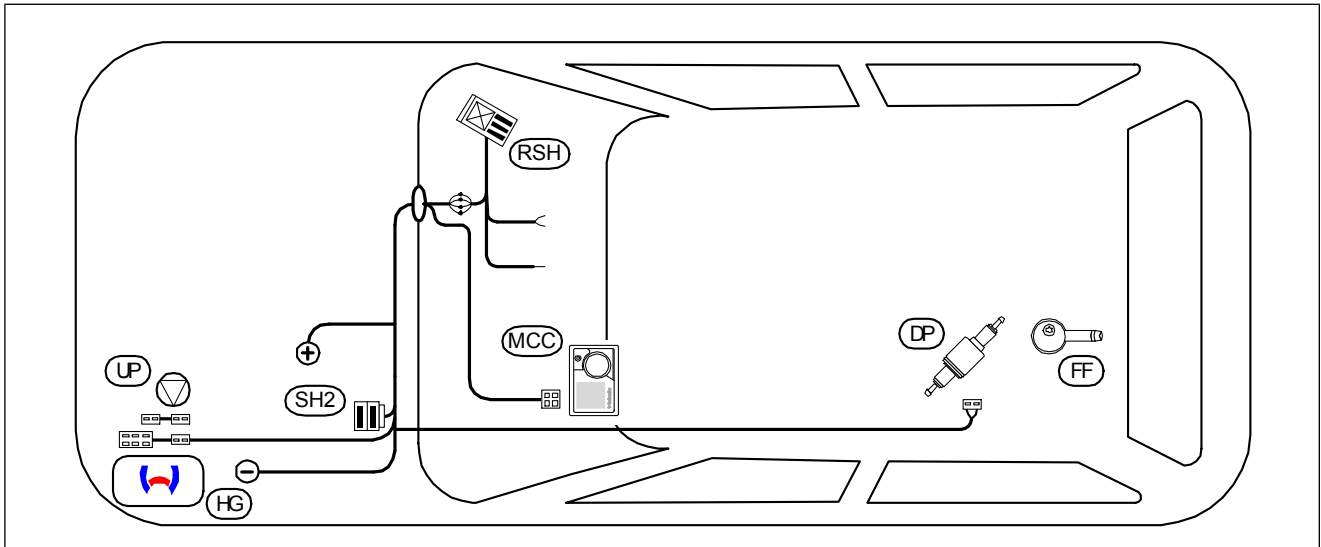
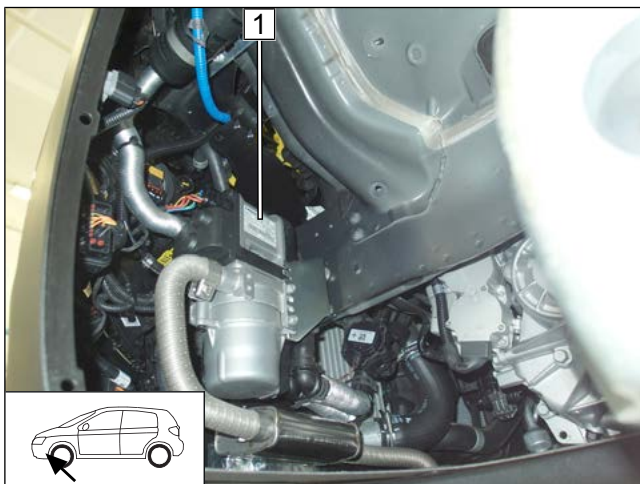

Fig. 1

Legend to installation overview

Abbreviation	Component
DP	Fuel pump
FF	FuelFix
HG	Heater
MCC	MultiControl CAR
RSH	Relay and fuse holder of passenger compartment
SH2	Engine compartment fuse holder for F1/F2
UP	Coolant pump

Heater installation location



1 Heater

Fig. 2



## 7 Electrical system of engine compartment

### Preparing fuse holder of engine compartment

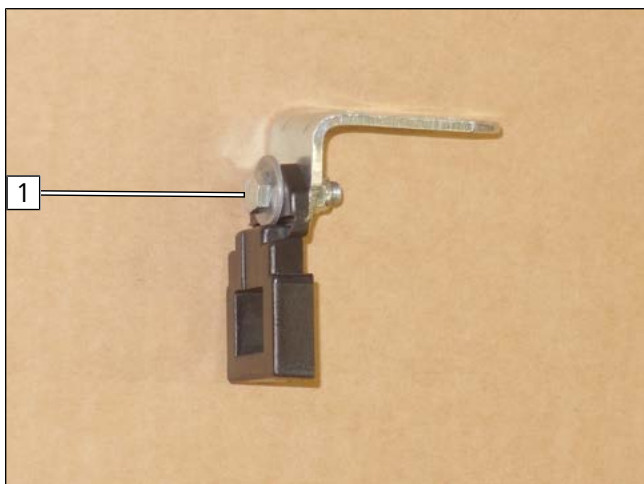

Fig. 3

- 1 M5x16 bolt, large diameter washer, retaining plate of SH2, angle bracket, large diameter washer, nut

### Mounting retaining plate of SH2

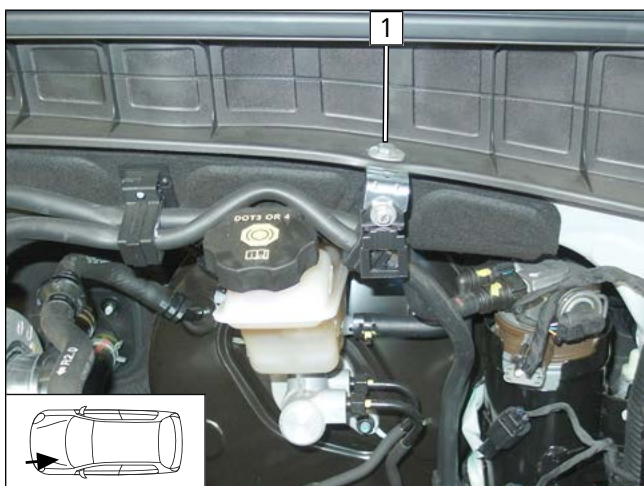

Fig. 4

► Remove clip at pos. 1.

- 1 M6x20 bolt, large diameter washer, original vehicle hole, premounted angle bracket, large diameter washer, flanged nut

### Installing SH2

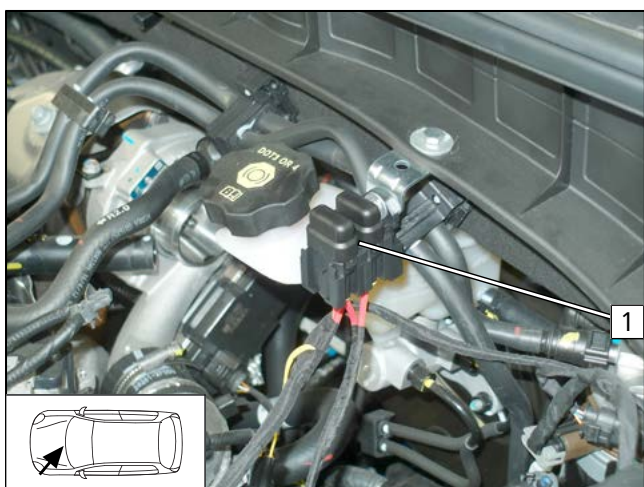

Fig. 5

- 1 Fuses F1 / F2



## Earth wire connection

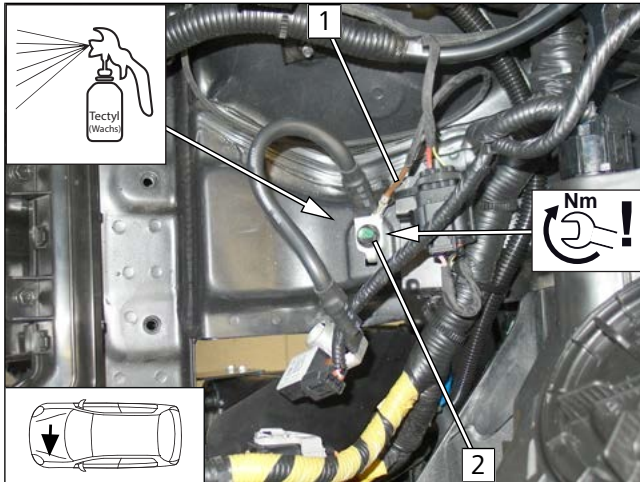

Fig. 6



### DANGER

Fire hazard due to insufficient tightening torque

► Observe tightening torque

- 1 Earth wire
- 2 Original vehicle earth point

## Positive wire connection

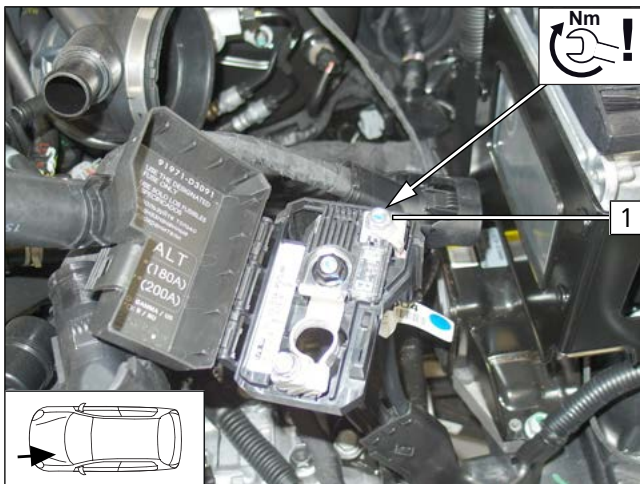

Fig. 7



### DANGER

Fire hazard due to insufficient tightening torque

► Observe tightening torque

- 1 Positive wire on positive distributor

## Passenger compartment wiring harness pass through

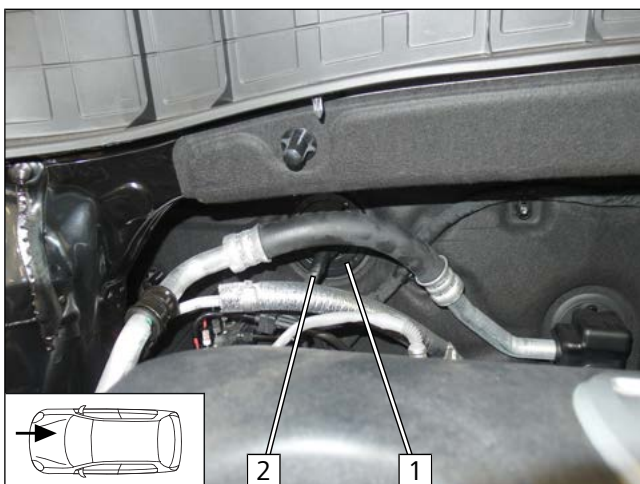

Fig. 8

- 1 Protective rubber plug
- 2 Passenger compartment and control element wiring harnesses





## 8 Mechanical system

### 8.1 Preparing installation location

#### Removing original vehicle relay

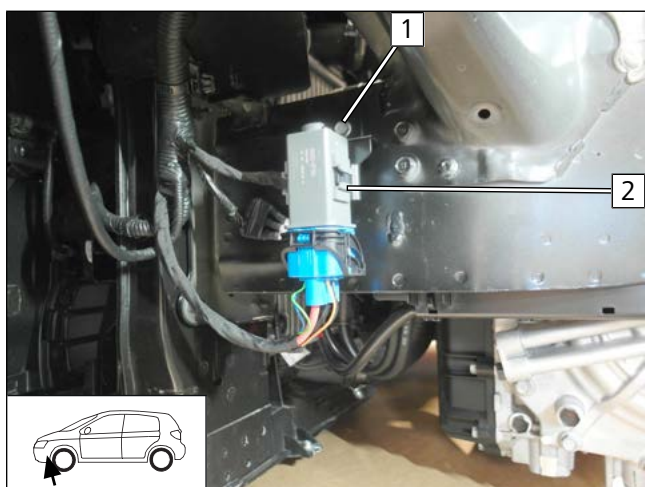

Fig. 9

- 1 Original vehicle bolt, will be reused
- 2 Original vehicle relay (grey or black)

#### Detaching original vehicle earth points, mounting angle bracket

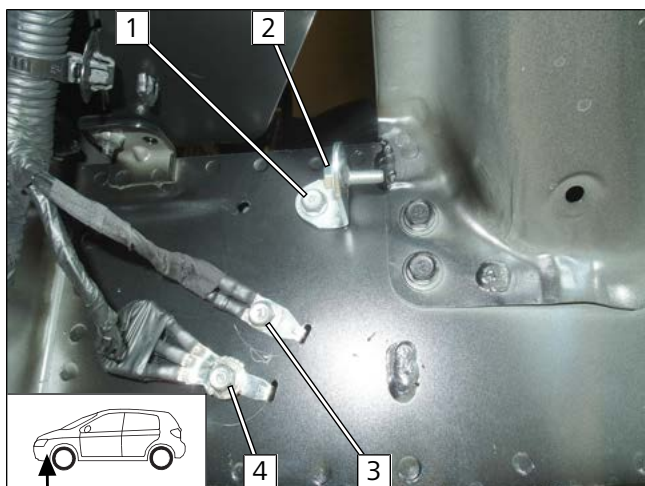

Fig. 10

- 1 Original vehicle bolt, angle bracket, original vehicle thread
- 2 M6x20 bolt, large diameter washer, angle bracket, lock washer
- 3 Original vehicle earth point a
- 4 Original vehicle earth point b

#### Inserting rivet nut

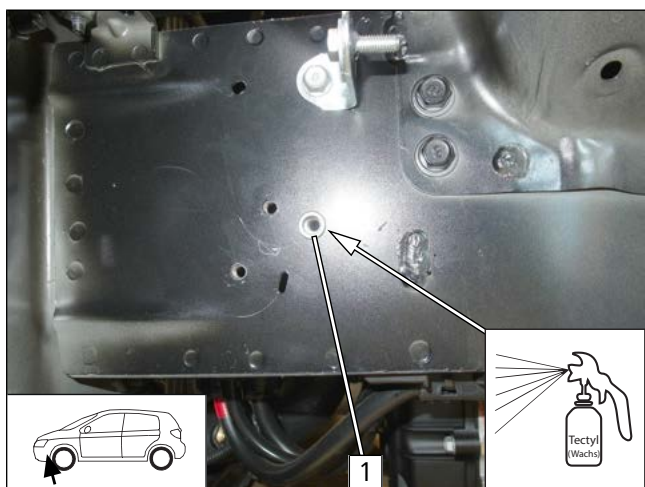

Fig. 11

- 1 Drill out oblong hole to Ø9, insert rivet nut



## Copying hole pattern

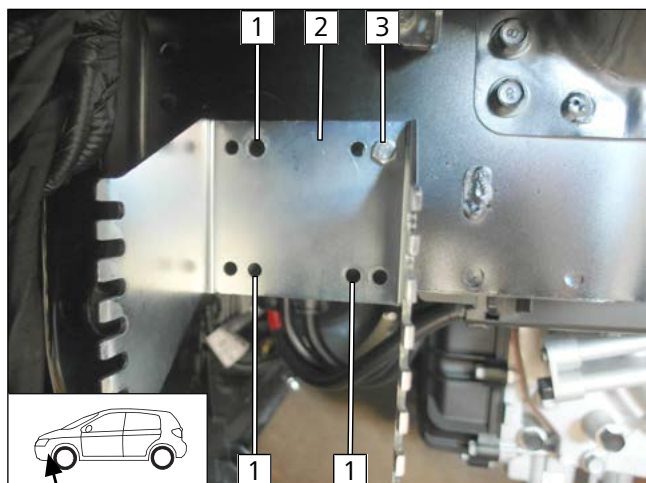

Fig. 12

► Mount bracket **2** loosely and align as shown in Fig.

- 1** Copying hole pattern
- 3** M6x30 bolt

► Remove bracket.

## Drilling holes and inserting rivet nut

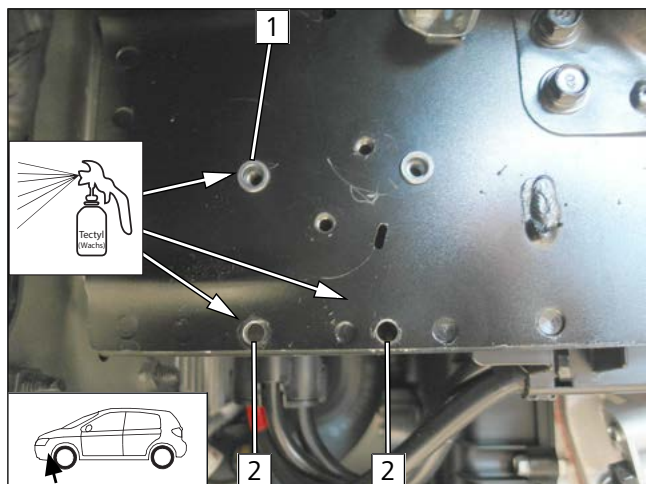

Fig. 13

- 1** Ø9 hole, rivet nut
- 2** Ø7 hole

## Mounting earth point

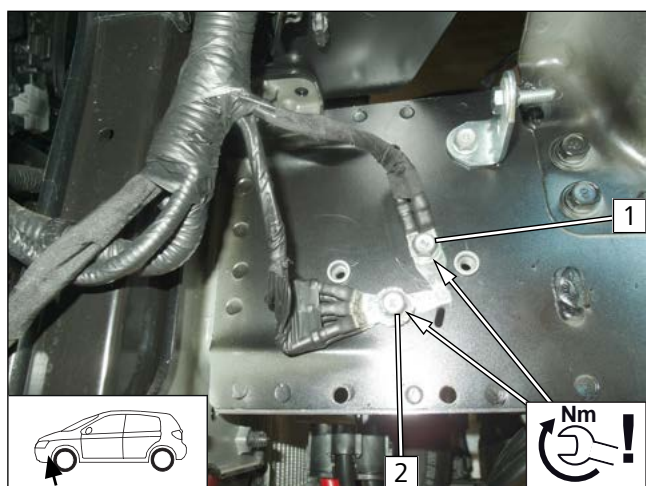

Fig. 14

► Straighten earth points **a** and **b**.

- 1** Original vehicle bolt, earth point **a**
- 2** Original vehicle bolt, earth point **b**



## Mounting bracket

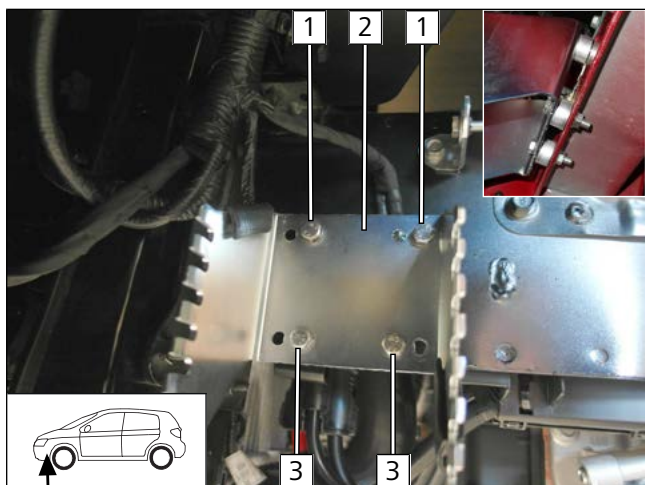

Fig. 15

- 1** M6x30 bolt, spring lockwasher, 8mm distance washer
- 2** Bracket
- 3** M6x30 bolt, distance washer (8), M6 nut

## Mounting original vehicle relay

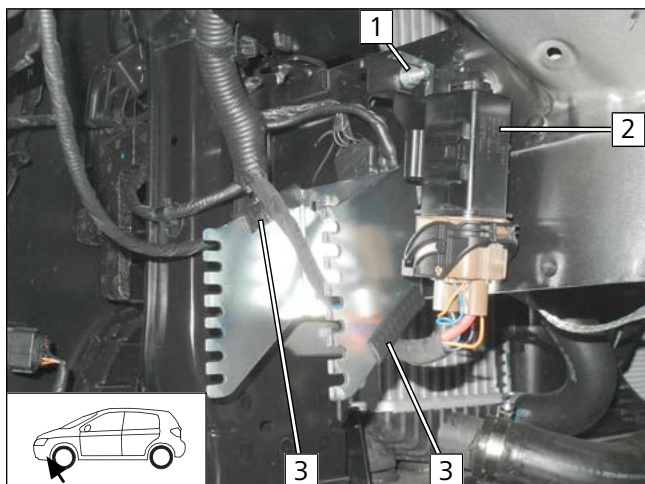

Fig. 16

► Route wiring harness of original vehicle relay **2** as shown.

- 1** Premounted bolt, relay bracket, flanged nut
- 3** 50 long edge protection

## Inserting rivet nut for air intake silencer

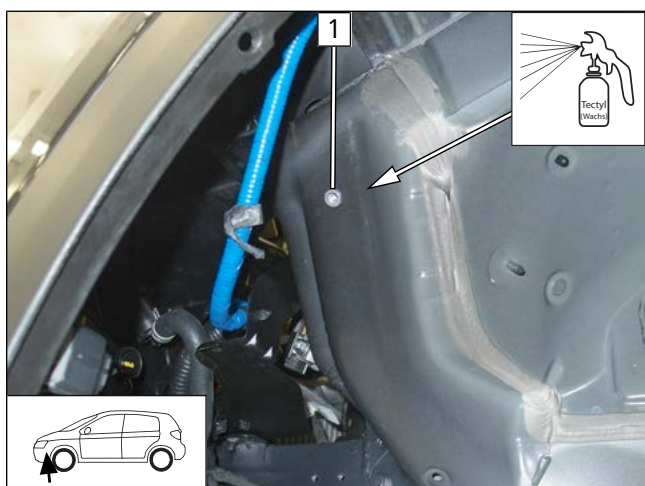

Fig. 17

- 1** Rivet nut in original vehicle hole





## Removing original vehicle earth strap with retaining clip from hole

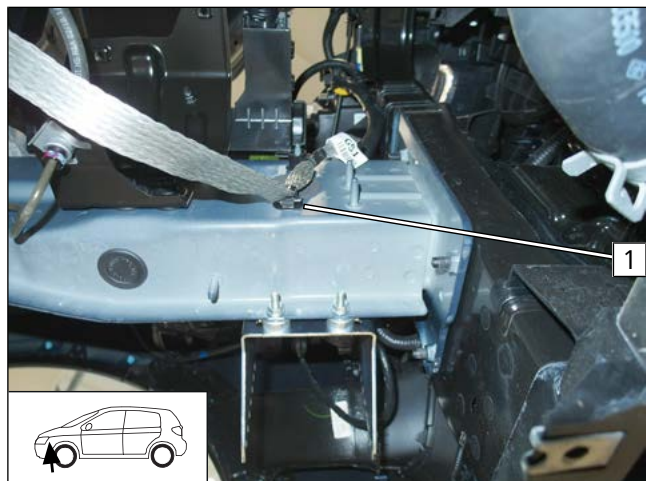



Fig. 18

 1.6 CRDi only

- 1 Original vehicle earth strap, retaining clip

## Inserting rivet nut for coolant pump

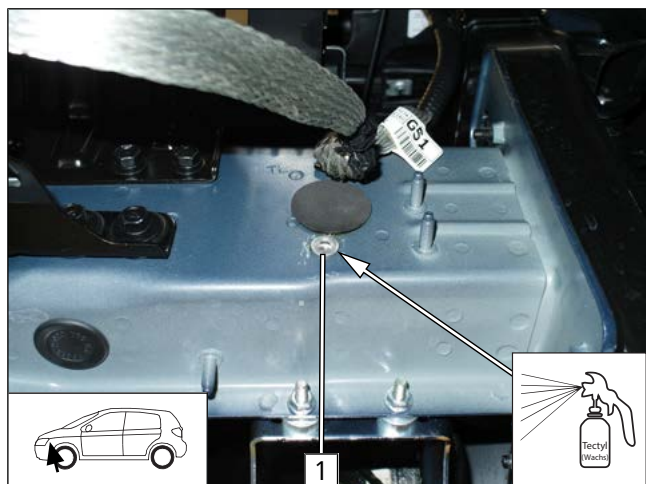

Fig. 19

► Drill out original vehicle hole to Ø9.

- 1 M6 rivet nut in original vehicle hole

## Hole for exhaust silencer

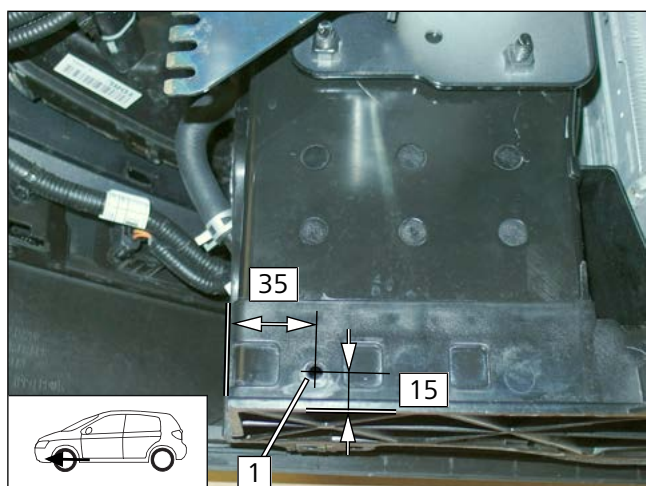



Fig. 20

 all vehicles

- 1 Ø7 hole





Fixing original vehicle wiring harnesses, if available

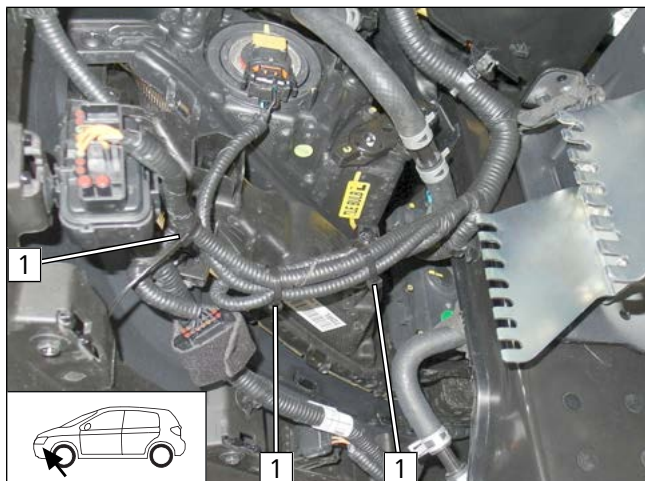

1 Cable tie

Fig. 21

## 8.2 Premounting heater

Premounting bolts loosely

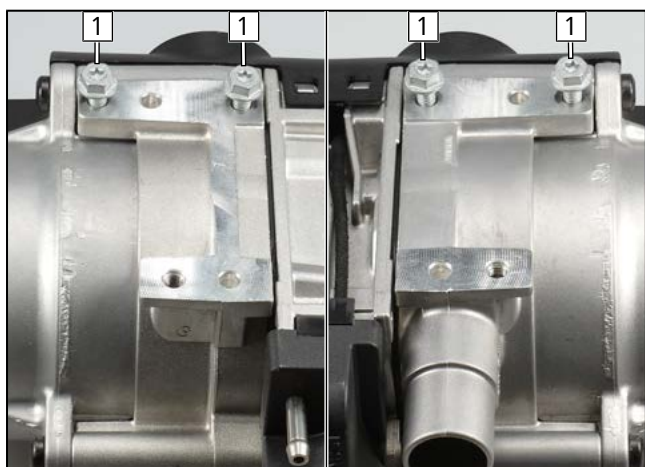

► Screw 5x13 self-tapping bolts 1 into existing holes by a maximum of 3 thread turns.

Fig. 22

Mounting water connection piece

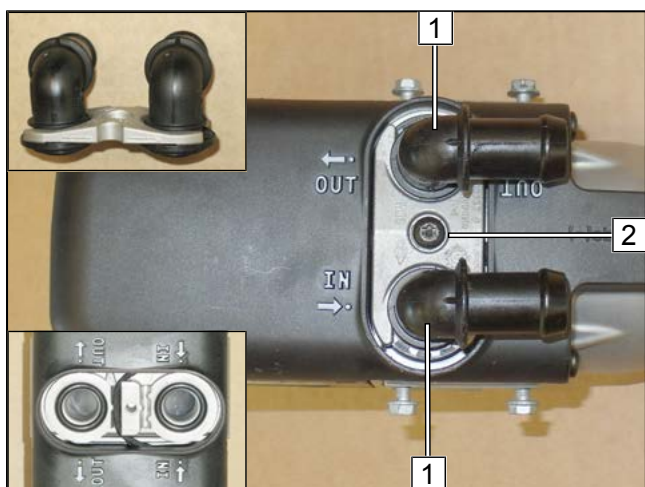

 Observe the general installation instructions of the heater.

- 1 90° water connection piece, seal
- 2 5x15 self-tapping bolt, water connection piece retaining plate

Fig. 23



## Cutting combustion air pipe to length

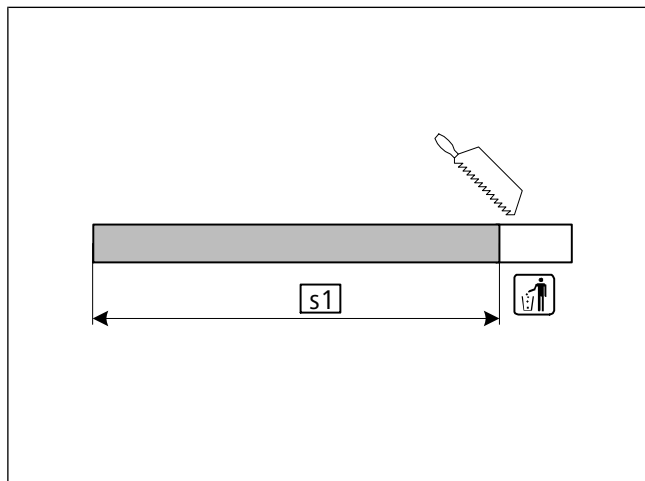

Fig. 24

s1 330

## Mounting combustion air intake pipe and fuel line

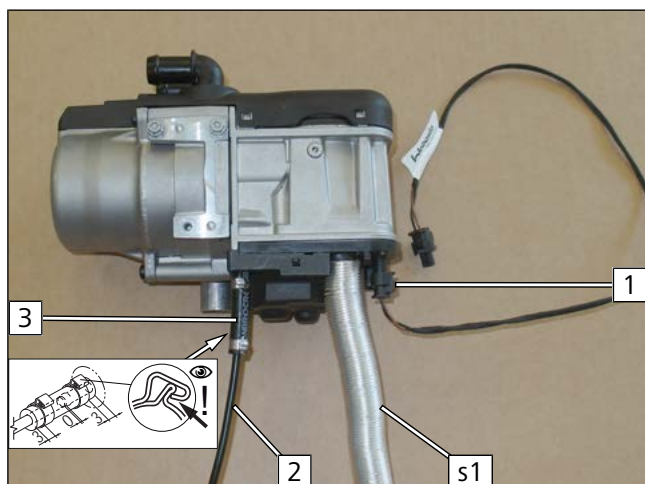

Fig. 25

Observe the general installation instructions of the heater.

- 1 Coolant pump wiring harness connector
- 2 Fuel line
- 3 Hose section, Ø10 clamp [2x]

## Cutting hoses to length

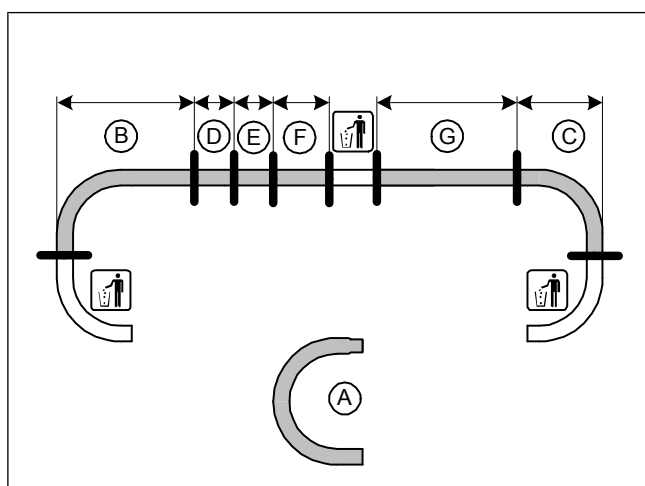

Fig. 26

	1.6 CRDi	2.0 CRDi
A	Ø15x20, turned by 180°	Ø15x20, turned by 180°
B	640	870
C	185	110
D	60	60
E	60	60
F	170	170
G	720	890



## Premounting hoses

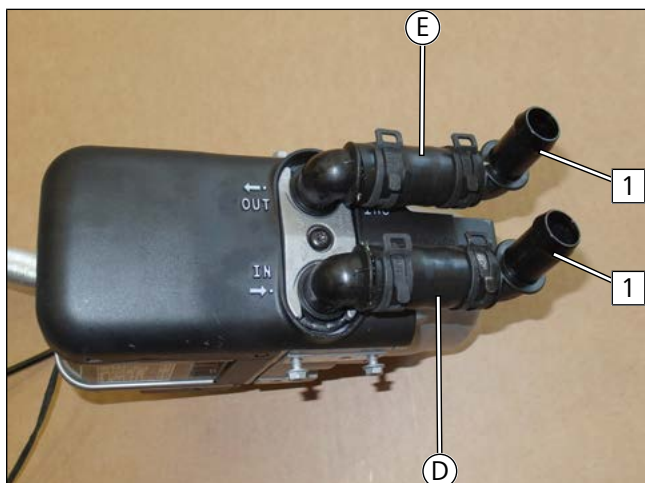

Fig. 27



All spring clips  $\varnothing 25$

- 1  $\varnothing 18 \times 18$  90° connecting pipe

## 8.3 Heater mounting

### Mounting heater

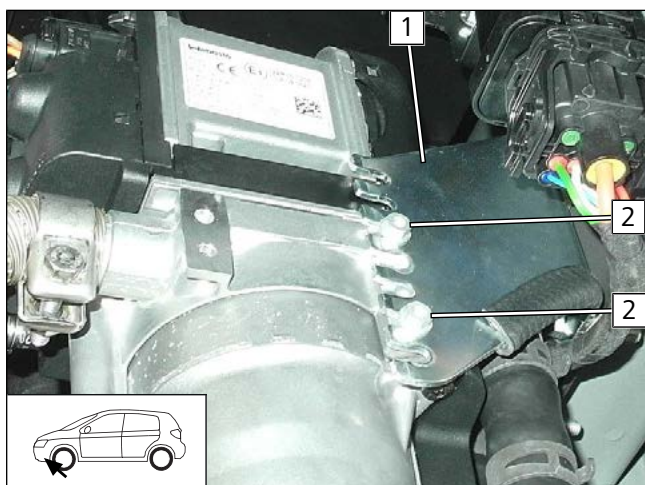

Fig. 28

- 1 Bracket
- 2 5x13 self-tapping bolt

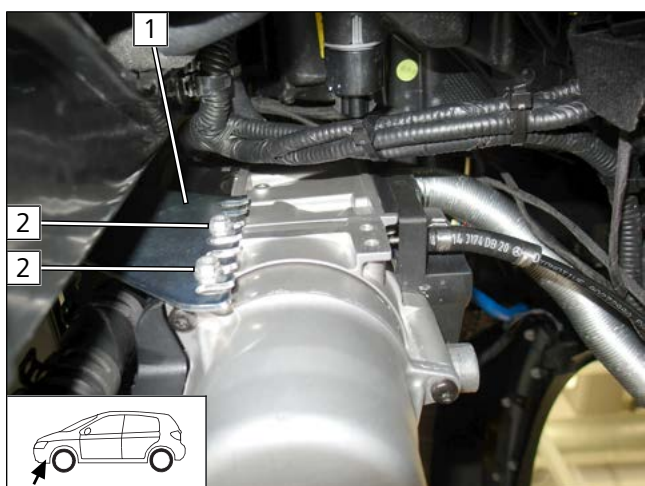
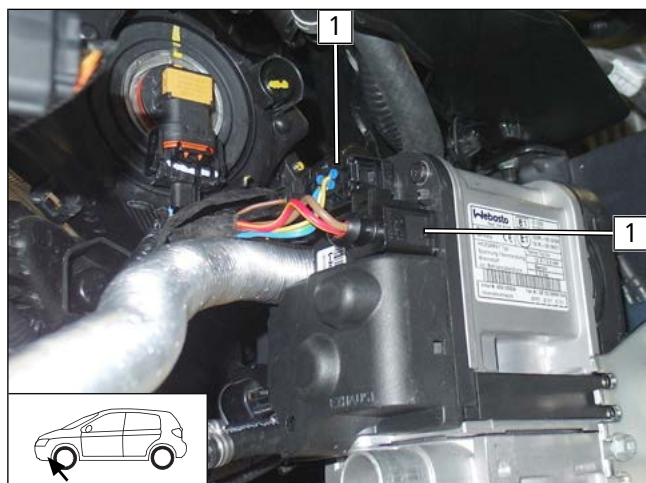

Fig. 29

- 1 Bracket
- 2 5x13 self-tapping bolt



## Mounting HG wiring harness connector



- 1 Heater wiring harness connector

Fig. 30



## 9 Fuel



### DANGER

**Risk of fire and explosion due to leaking fuel and escaping fuel vapours.**

The incorrect installation of the fuel extractor can cause damage and fire.

- ▶ Avoid electrostatic discharges and open fire
- ▶ When working on the fuel system, ensure sufficient ventilation and bleeding
- ▶ Open the fuel tank cap of the vehicle
- ▶ Ventilate the fuel tank
- ▶ Re-close the tank lock
- ▶ Catch any fuel running off with an appropriate container



### Danger of damage to components

- ▶ Install fuel line and fuel pump wiring harness so that they are protected against stone impact
- ▶ Provide rub protection for fuel line and wiring harness in areas where there are sharp edges

### Dismantling fuel pump connector X7

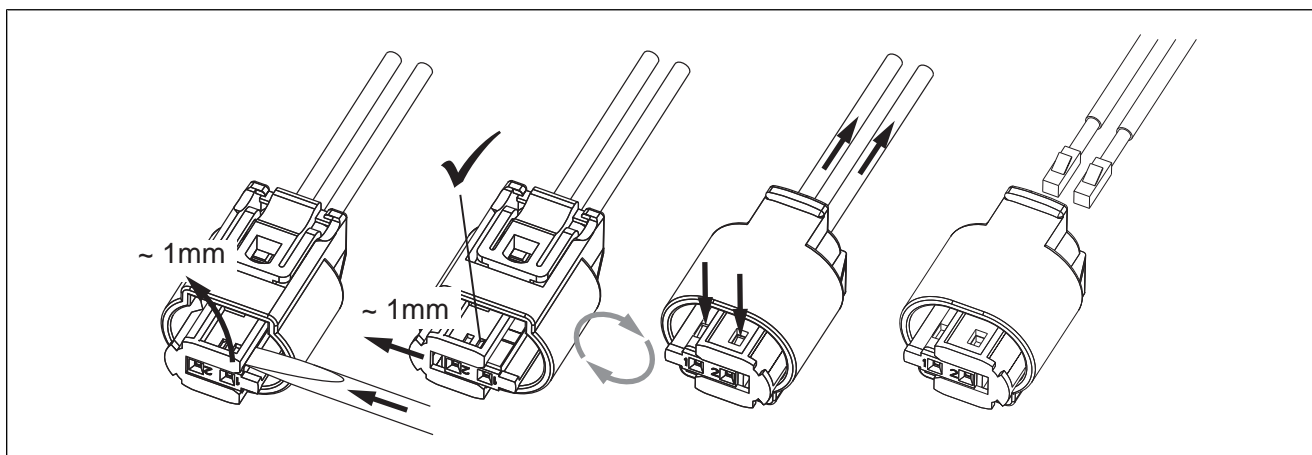

Fig. 31

## 9.1 Routing fuel line

### Connecting heater

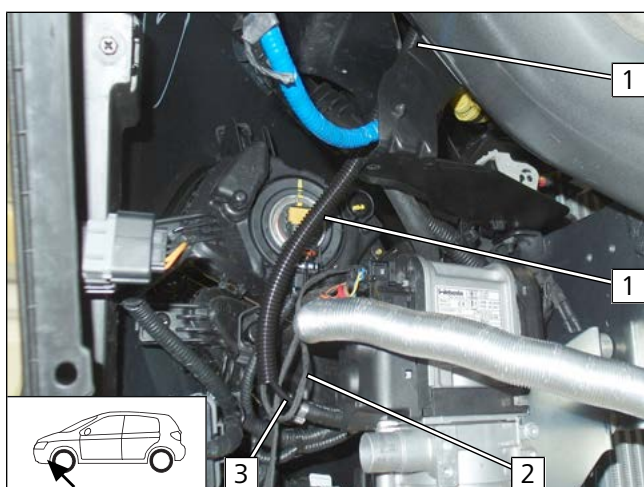

Fig. 32

- ▶ Draw fuel line **3** and fuel pump wiring harness **2** into Ø10 corrugated tube **1** and route into the engine compartment.





## Installing lines

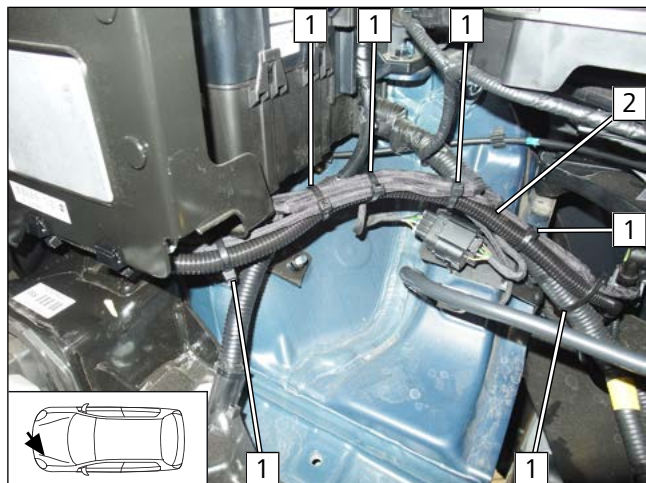

Fig. 33

- 1 Cable tie
- 2 Fuel line and fuel pump wiring harness in Ø10 corrugated tube

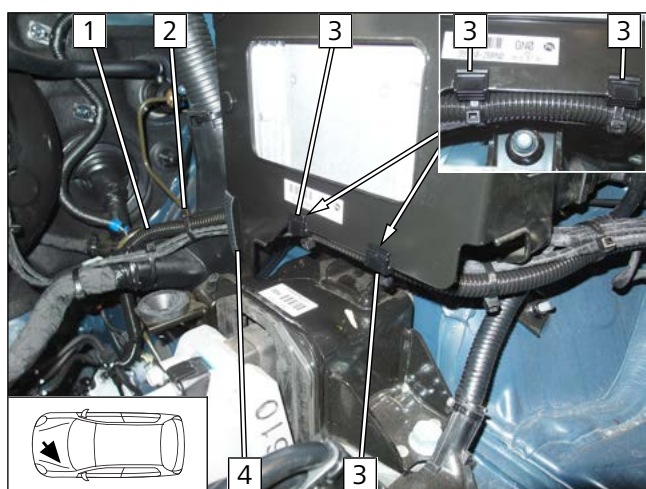

Fig. 34

- 1 Fuel line and fuel pump wiring harness in Ø10 corrugated tube
- 2 Cable tie
- 3 Edge clip cable tie
- 4 50 long edge protection

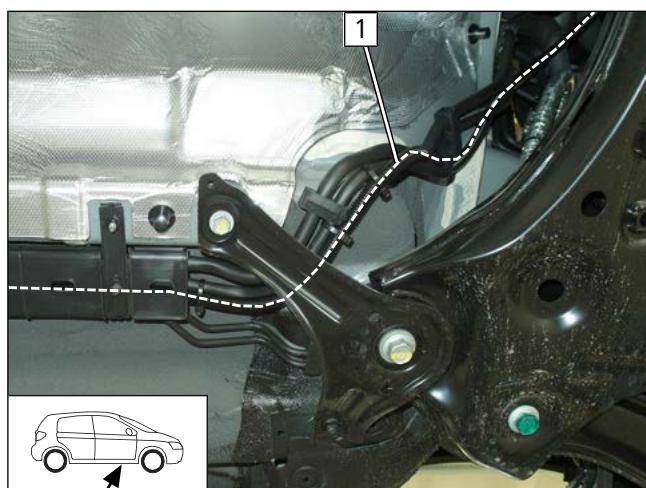

Fig. 35

- Route fuel line and fuel pump wiring harness in Ø10 corrugated tube 1 along original vehicle fuel lines to the underbody and secure with cable ties.

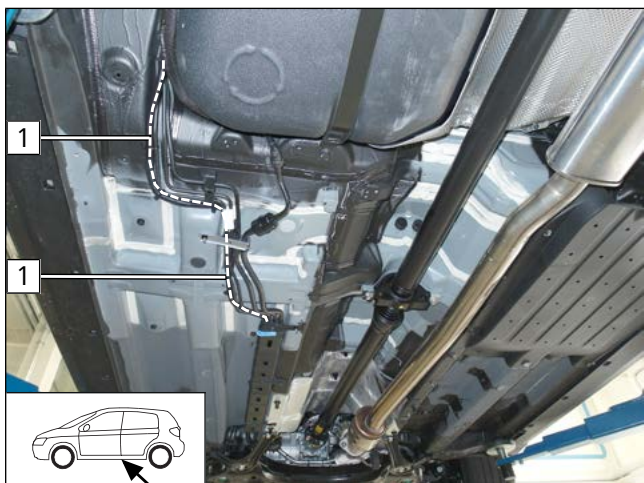

Fig. 36

► Route fuel line and fuel pump wiring harness in  $\varnothing 10$  corrugated tube **1** along original vehicle fuel lines to fuel pump installation location and secure using cable ties.

### Premounting fuel pump

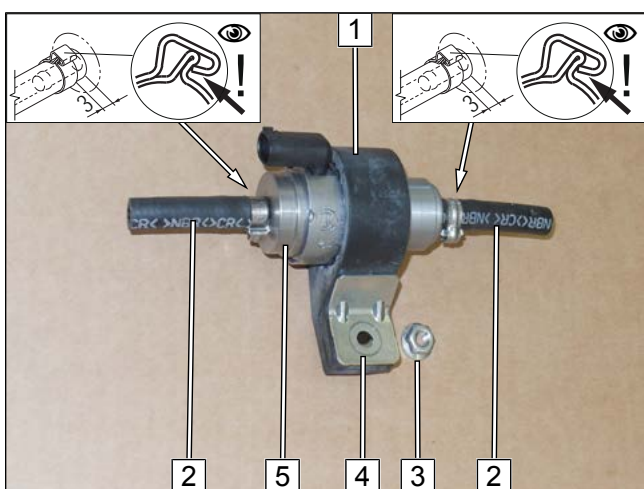

Fig. 37

- 1** Fuel pump mount
- 2** Hose section,  $\varnothing 10$  clamp
- 3** Flanged nut
- 4** Support angle bracket
- 5** Fuel pump

### Preparing fuel pump perforated bracket

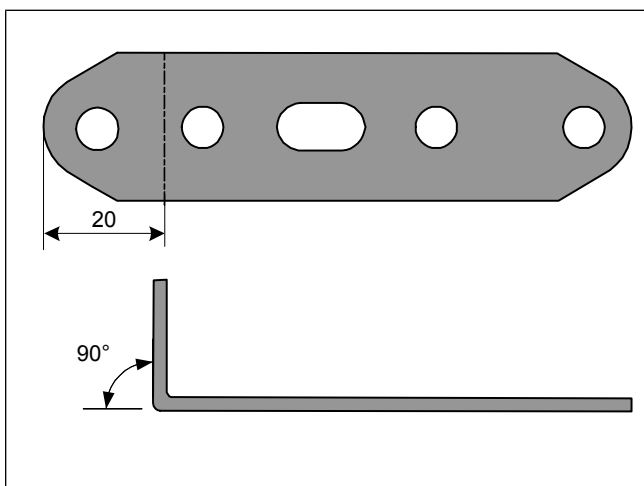

Fig. 38



## Premounting fuel pump perforated bracket

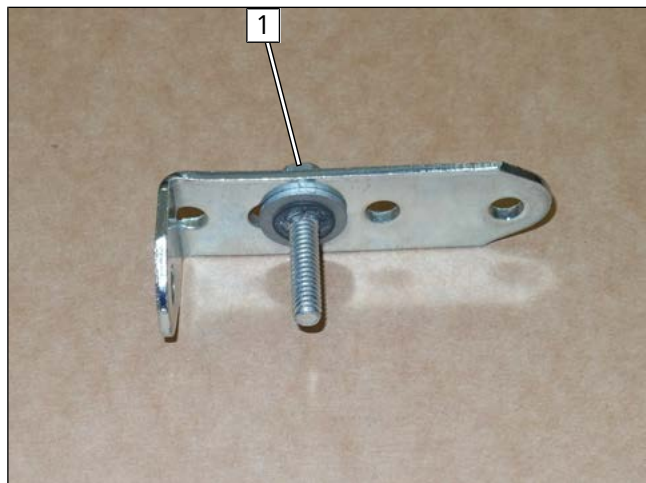

Fig. 39

- 1 M6x25 bolt, perforated bracket, large diameter washer, lock washer

## Mounting fuel pump perforated bracket

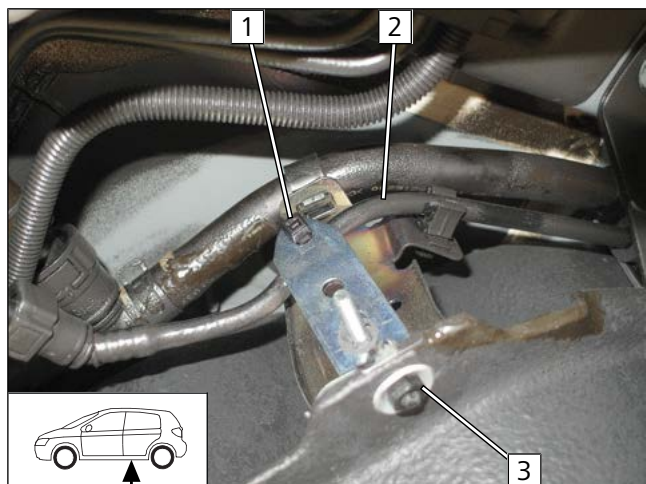

Fig. 40

- ▶ Fasten original vehicle line 2 using cable tie 1.
- ▶ Remove original vehicle bolt at position 3.
- 3 M6x20 bolt, perforated bracket, original vehicle bracket, original vehicle hole, original vehicle nut

## Mounting fuel pump



Fig. 41

- 1 Premounted bolt, premounted fuel pump, support angle bracket, flanged nut





## Assembling fuel pump connector X7

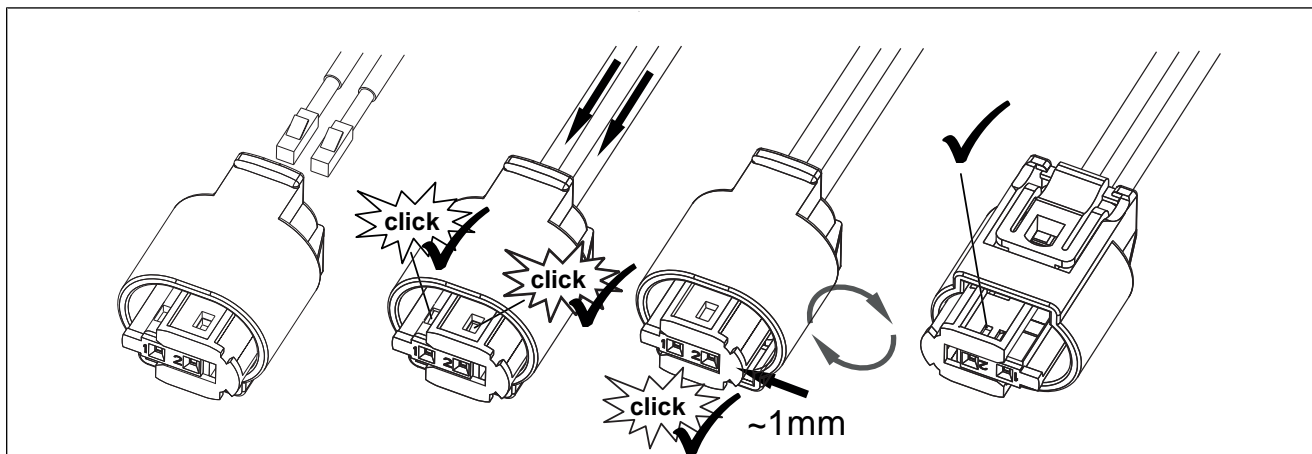
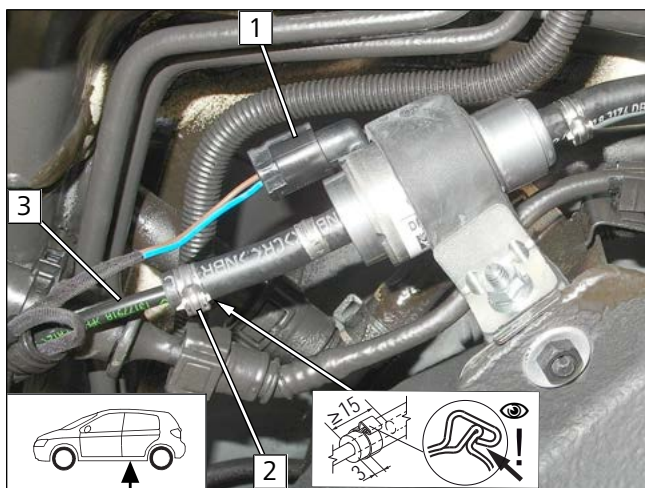

Fig. 42



- 1 Fuel pump wiring harness, connector X7 mounted
- 2 Ø10 clamp
- 3 Heater fuel line in Ø10 corrugated tube

Fig. 43

## 9.2 Installing FuelFix

### View of drilling template

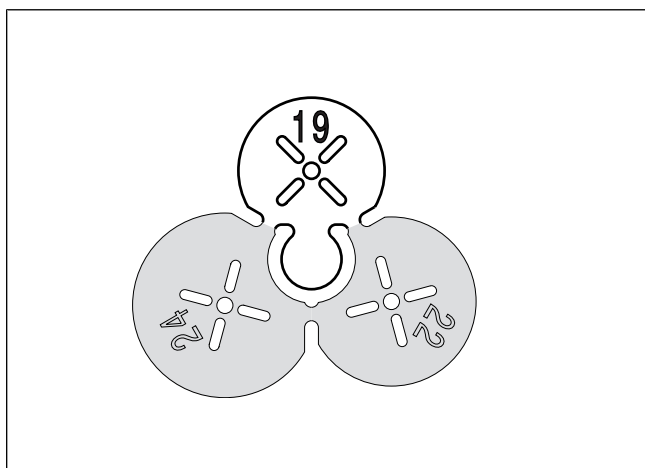

Fig. 44



## Work steps F1, F2

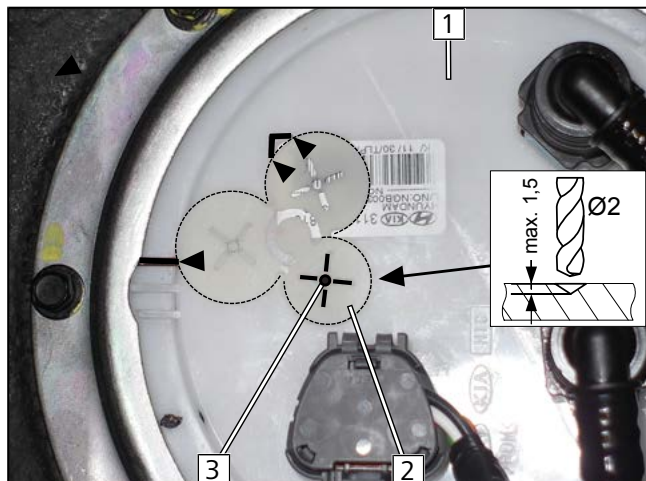

Fig. 45



Observe the installation instructions of the tank extracting device.

► Drill centring hole.

- 1 Tank fitting
- 2 Position Ø19 drilling template using the contours as shown
- 3 Ø2 centring hole

## Work step F3

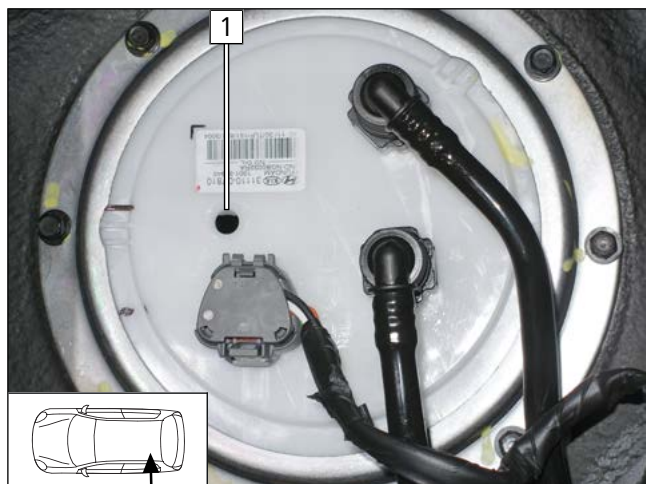

Fig. 46



### DANGER

Risk of fire and explosion due to leaking fuel and escaping fuel vapours.

► Drill hole for FuelFix.

- 1 Hole made with provided drill

## Work steps F4, F5



Fig. 47

► Bend FuelFix **1** as shown in template and cut to length.

► Insert FuelFix in hole **2**.



Work step F5



Fig. 48



Fig. 49



Fig. 50



## Work steps F5.3, F5.4

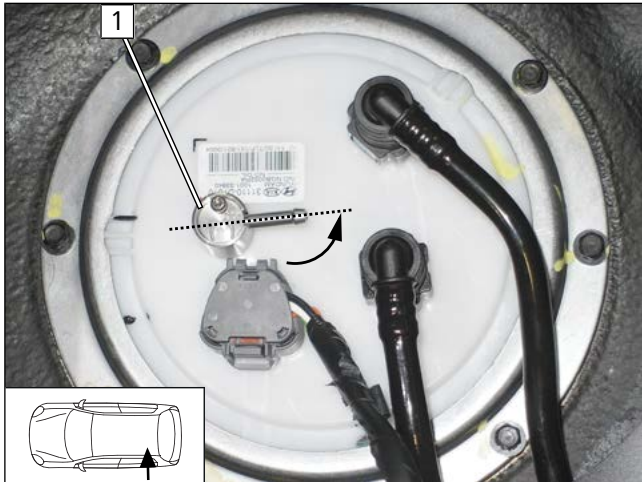

Fig. 51

► Align FuelFix **1** as shown in figure.

## Work step F6

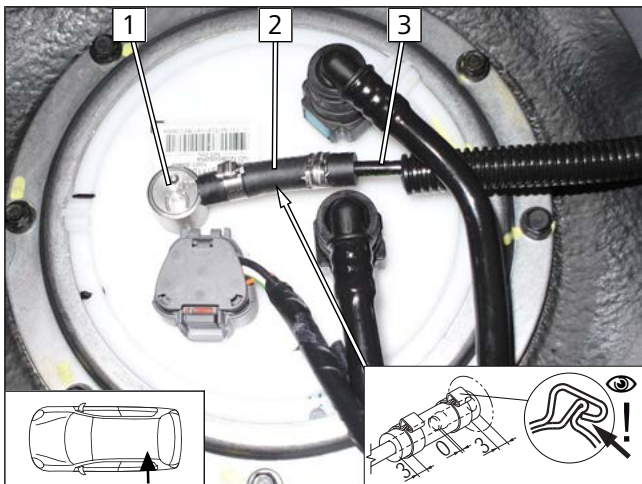

Fig. 52

► Connect fuel line.

- 1** FuelFix
- 2** Hose section, Ø10 clamp [2x]
- 3** Fuel line

## Work step F7

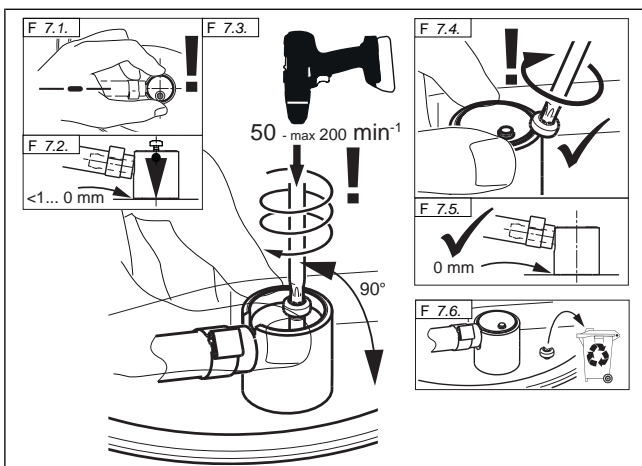

Fig. 53



## DANGER

Risk of fire and explosion due to leaking fuel and escaping fuel vapours.

► Mount FuelFix.





## Work step F8



Fig. 54

► Check firm seating of FuelFix.

## Securing fuel line



Fig. 55

**1** Cable tie for tension relief

## Connecting fuel pump

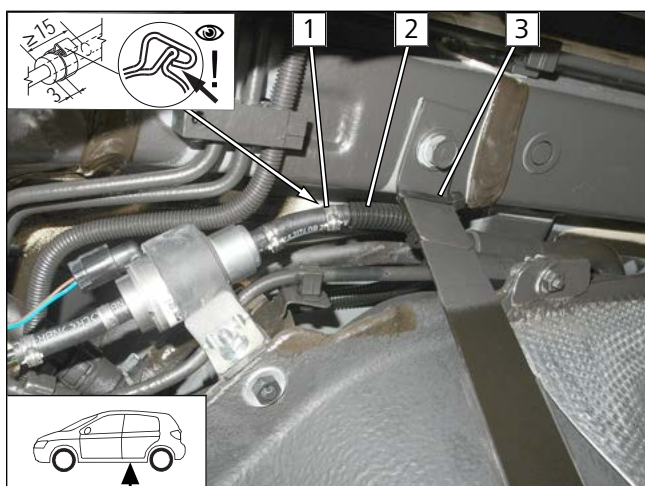

Fig. 56

- 1** Ø10 clamp
- 2** Fuel line FuelFix in Ø10 corrugated tube
- 3** Cable tie for tension relief



## 10 Combustion air

### Premounting combustion air intake silencer

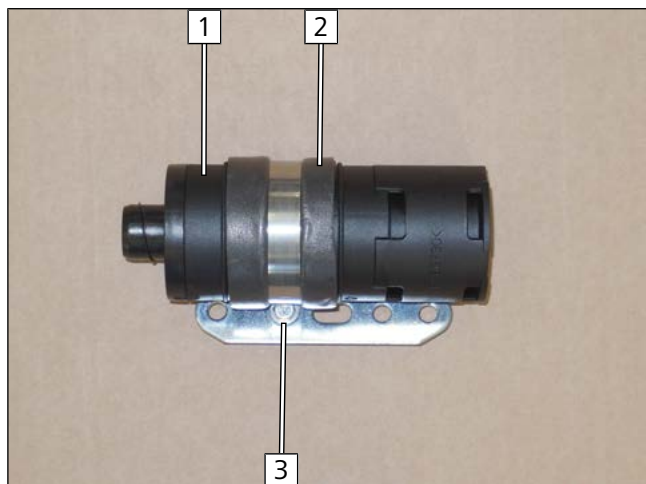

Fig. 57

- 1 Combustion air intake silencer
- 2 Self-adhesive foam
- 3 M5x16 bolt, Ø51 clamp, perforated bracket, large diameter washer, flanged nut

### Mounting combustion air intake silencer

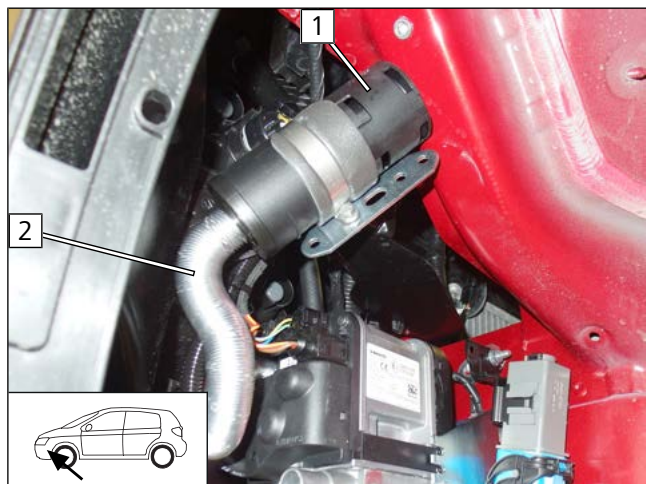

Fig. 58



Observe the installation instructions of the combustion air intake silencer.

- 1 Combustion air intake silencer
- 2 Combustion air pipe

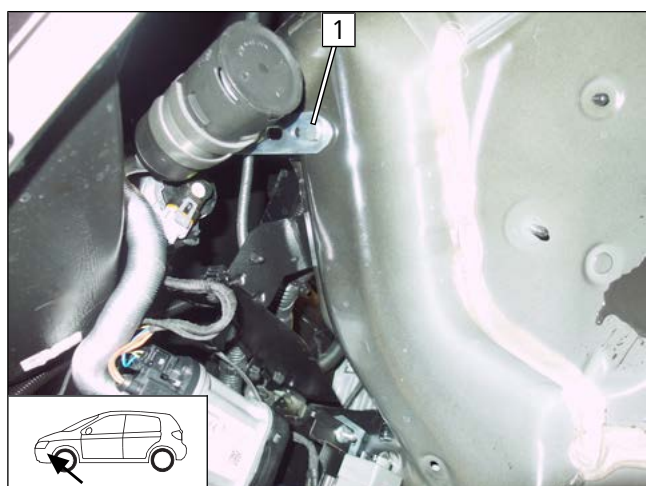

Fig. 59

- 1 M6x20 bolt, spring lockwasher, perforated bracket, rivet nut



## 11 Coolant for 1.6 CRDi

### 11.1 Hose routing diagram

'Inline' coolant circuit

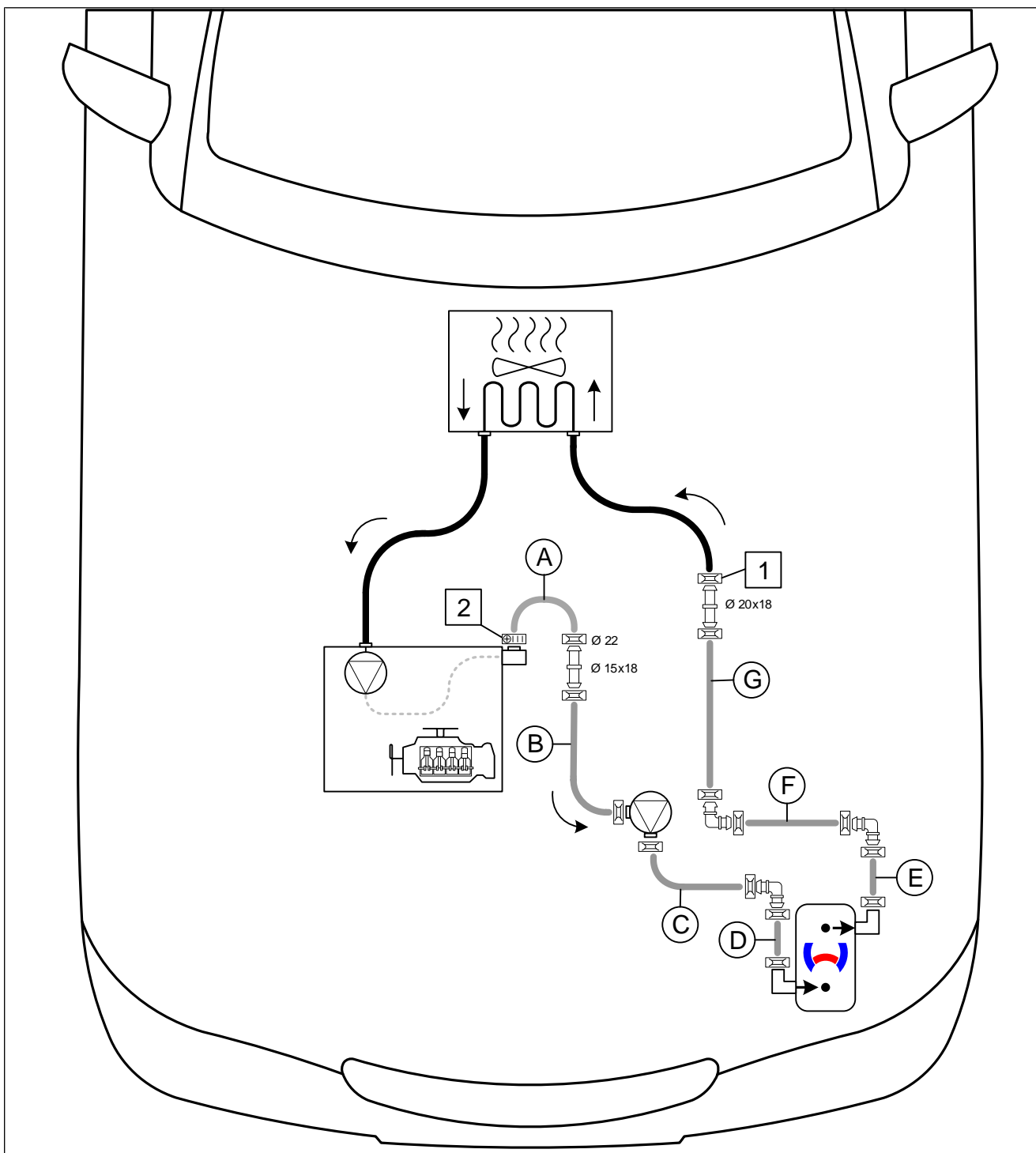



Fig. 60

All spring clips without a specific designation  = Ø25

All connecting pipes without a specific designation  = Ø18x18

**1** Original vehicle spring clip; **2** Ø16-27 hose clip



## 11.2 Preliminary Work

### Mounting black (sw) rubber isolator

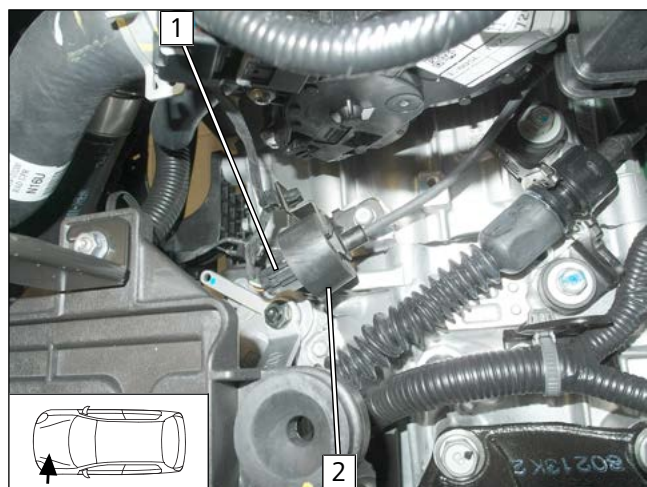

- ▶ Disconnect original vehicle connector at position **1**, mount black (sw) rubber isolator **2** as shown and re-connect connector.

Fig. 61

### Preparing perforated bracket A

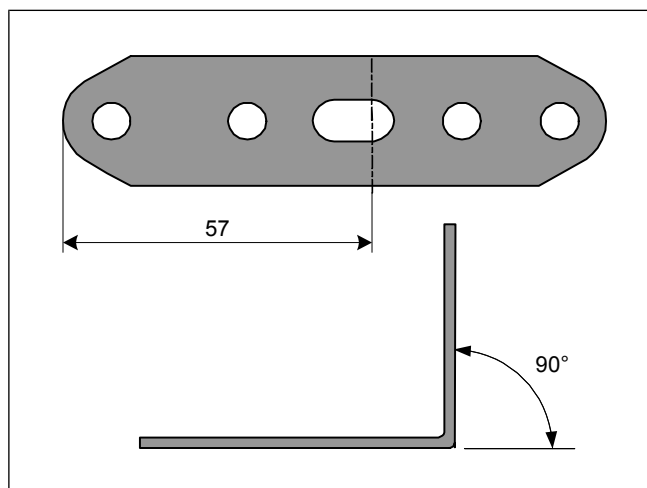

Fig. 62

### Preparing perforated bracket B

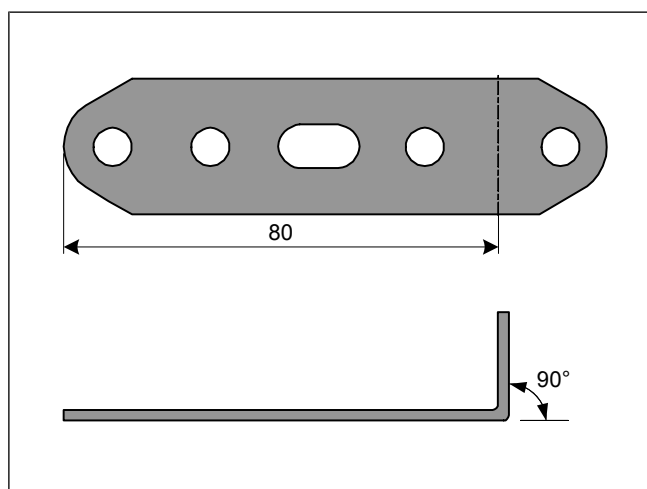

Fig. 63



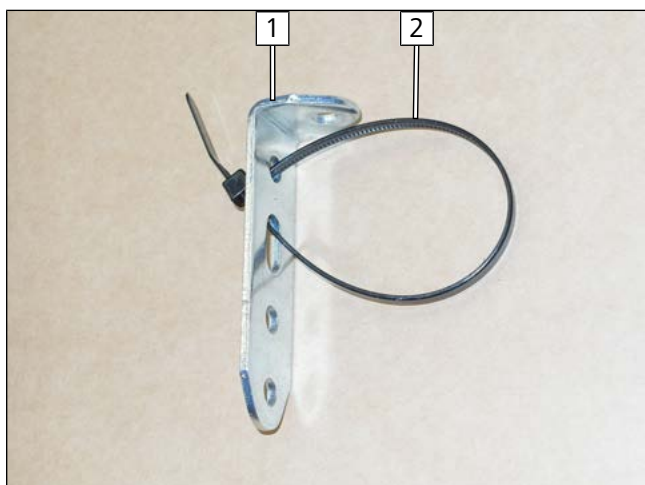

Fig. 64

- 1 Perforated bracket B
- 2 Cable tie

### Preparing coolant pump mount

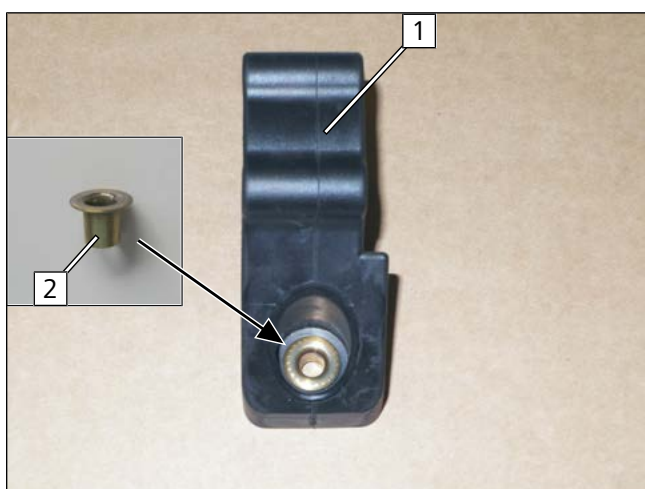

Fig. 65

- 1 Coolant pump mount
- 2 Sleeve

### Premounting coolant pump

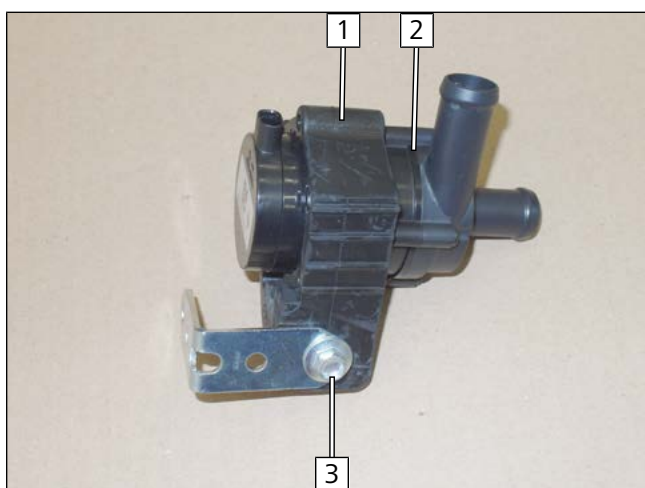

Fig. 66

- 1 Coolant pump mount
- 2 Coolant pump
- 3 M6x25 bolt, coolant pump mount, perforated bracket A, large diameter washer, flanged nut



## Mounting coolant pump

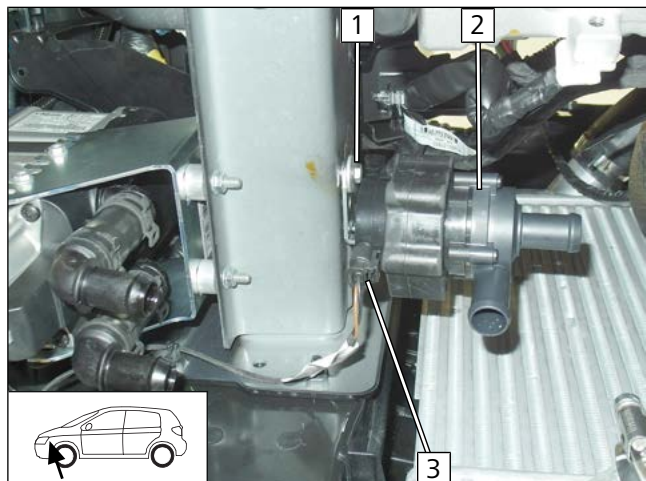

Fig. 67

- 1 M6x20 bolt, spring lockwasher, perforated bracket, rivet nut
- 2 Coolant pump
- 3 Coolant pump wiring harness connector

## Mounting perforated bracket B

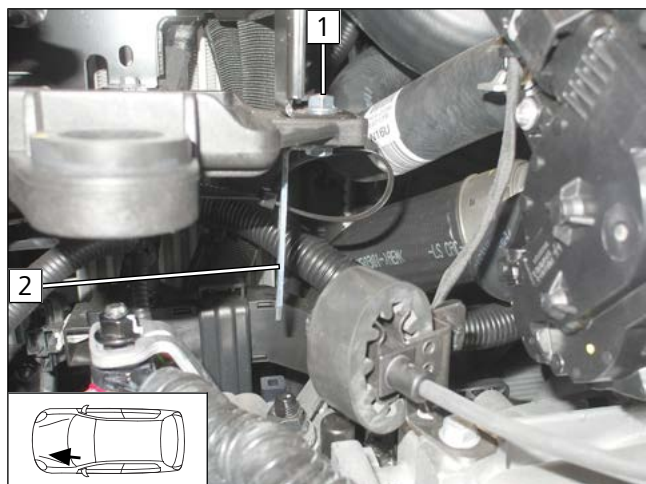

Fig. 68

- ▶ Discard original vehicle bolt at position 1.
- 1 M6x20 bolt, original vehicle bracket, perforated bracket B, flanged nut
- 2 Perforated bracket B

## Mounting fabric heat shrink tubing

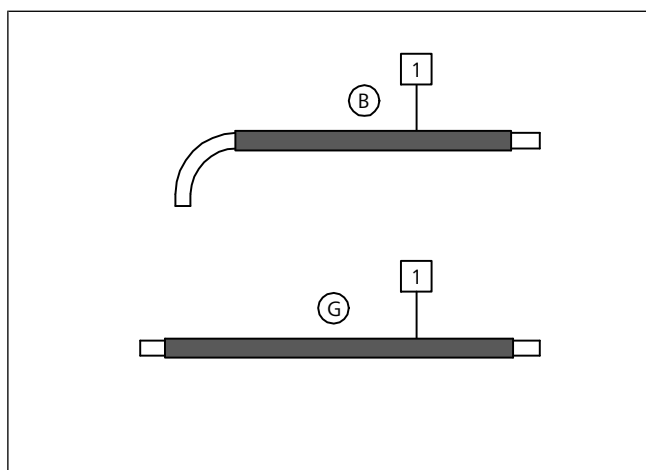

Fig. 69

- ▶ Push fabric heat shrink tubings 1 onto hoses B and G, cut to length and shrink.



## Mounting heat protection hose

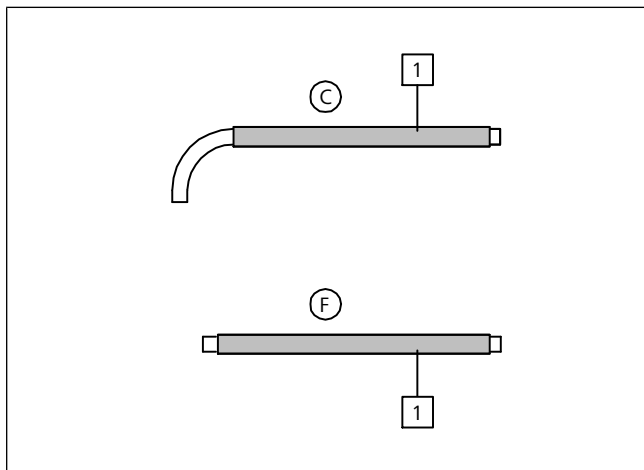

Fig. 70

► Cut heat protection hose to length and push onto hoses **C** and **F**.

**1** Heat protection hose

## Premounting hose **A**

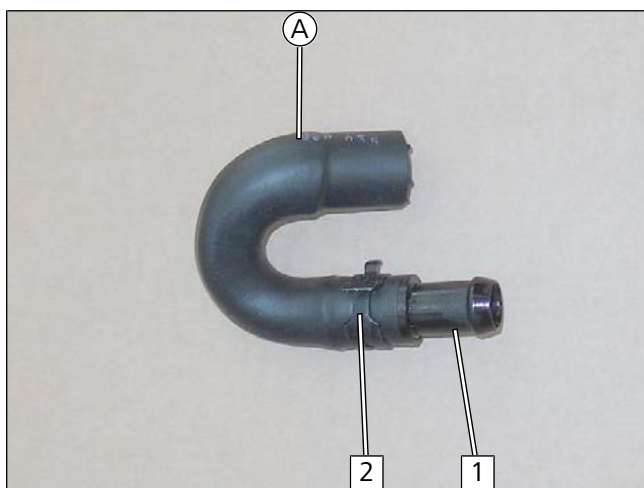

Fig. 71

**1** Ø15x18 connecting pipe

**2** Ø22 spring clip

## 11.3 Coolant circuit installation

### Heater outlet connection

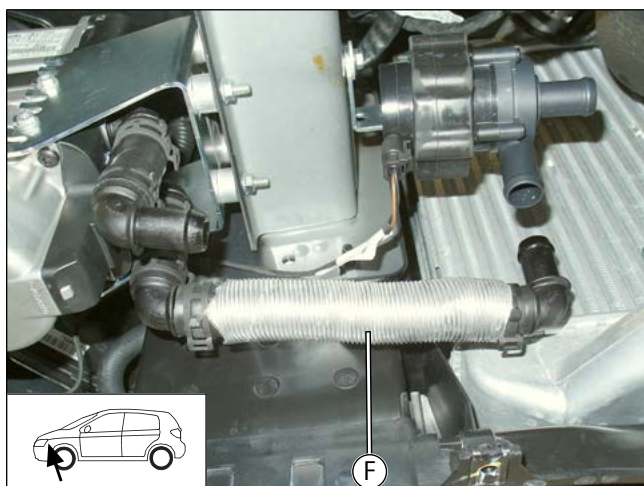

Fig. 72



## Heater inlet and coolant pump outlet connection

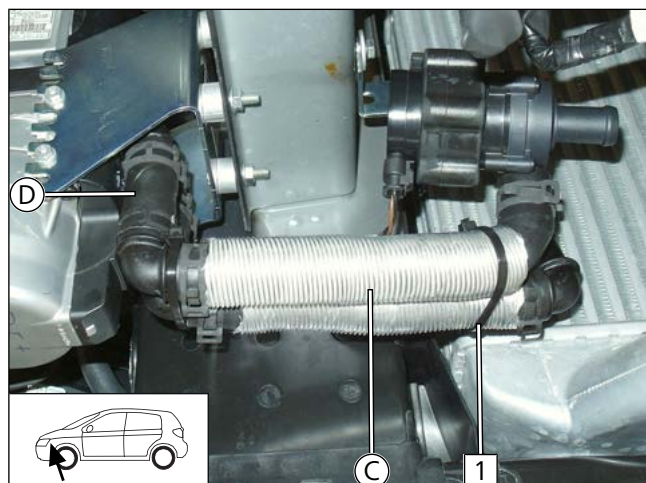

Fig. 73

- 1 Cable tie

## Connection of hose (B) and hose (G)

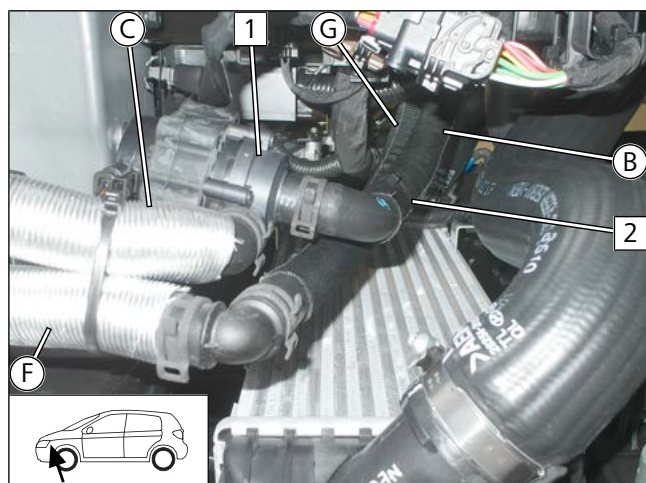

Fig. 74

- Route hoses (B) and (G) in the engine compartment.

- 1 Coolant pump
- 2 Cable tie

## Routing hoses (B) and (G)

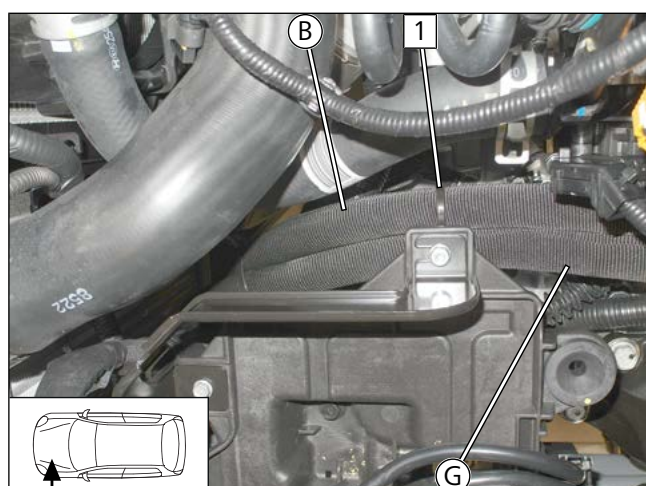

Fig. 75

- Route hoses (B) and (G) through pre-mounted cable tie to the cutting point.

- 1 Pre-mounted cable tie on perforated bracket





## Cutting point

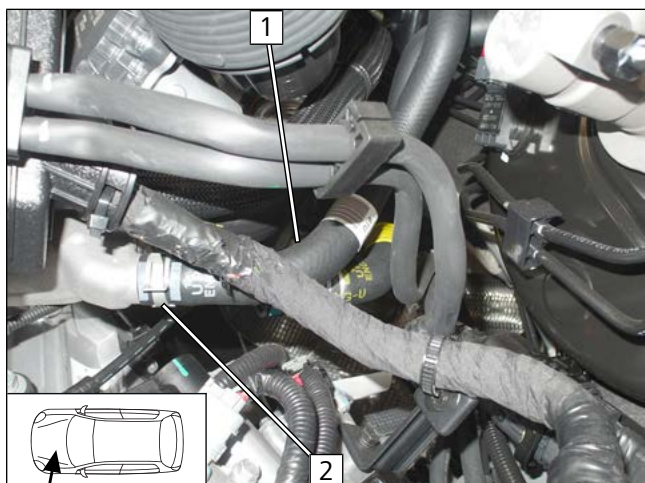

Fig. 76

- ▶ Remove engine outlet / heat exchanger inlet hose **1** from engine outlet connection piece. Original vehicle spring clip **2** will be reused.

## Mounting hose **A**

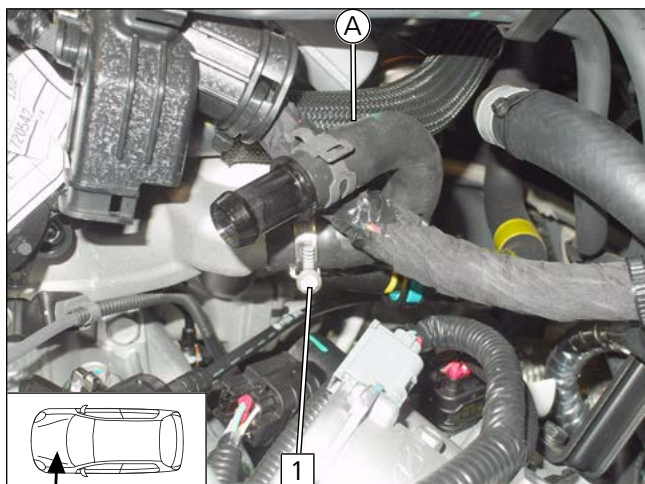

Fig. 77

- 1** Ø16-27 hose clip

## Connection of hose **B** to hose **A**

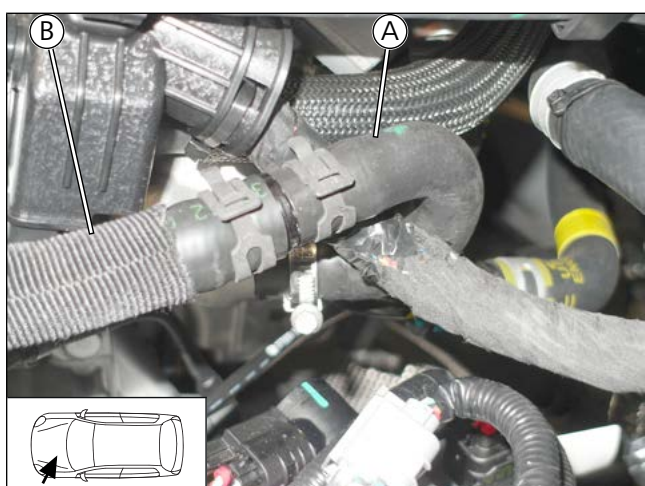

Fig. 78



## Connecting heat exchanger inlet hose section

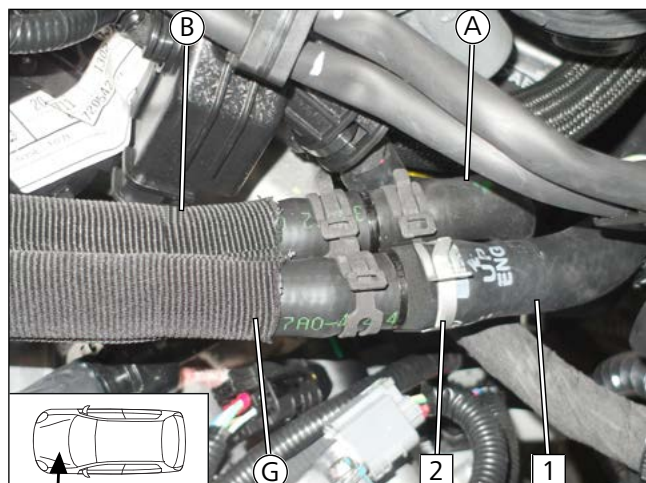

Fig. 79

- 1 Heat exchanger inlet hose section
- 2 Original vehicle spring clip

## Premounting edge clip cable tie

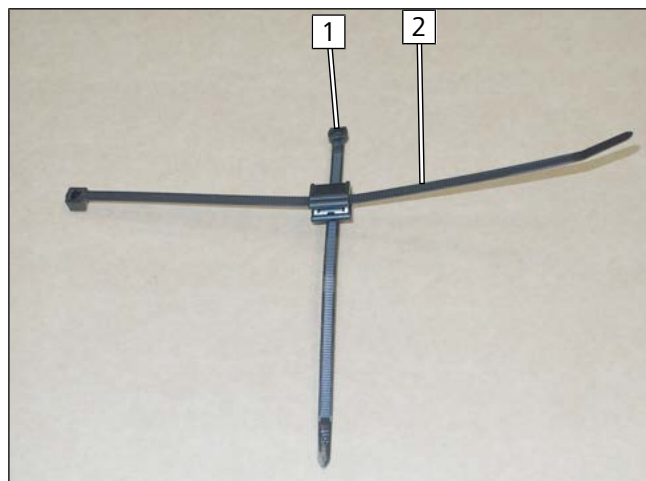

Fig. 80

- 1 Edge clip cable tie
- 2 Cable tie

## Fastening heat exchanger inlet hose section

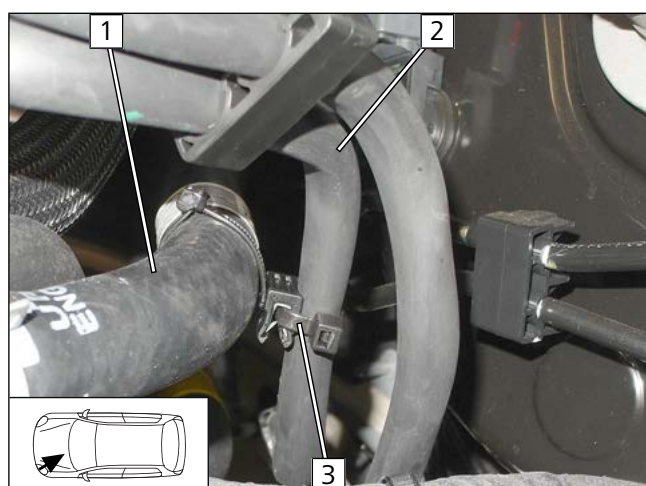

Fig. 81

- 1 Heat exchanger inlet hose section
- 2 Original vehicle fuel line
- 3 Premounted edge clip cable tie



## Fastening hoses **B** and **G**

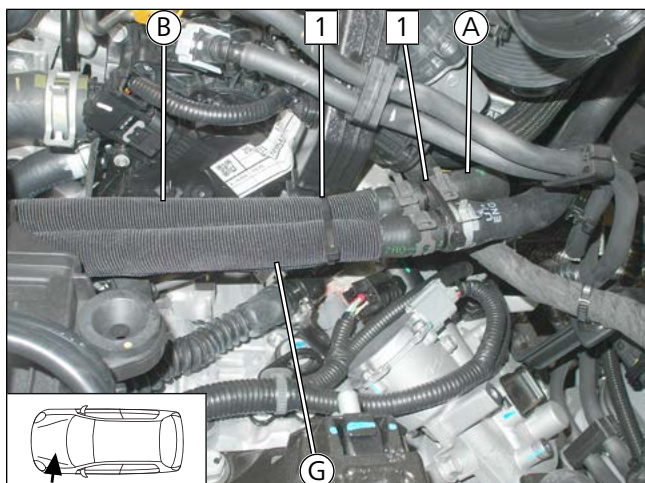

Fig. 82



Danger of damage to components

► Ensure sufficient distance from neighbouring components, correct if necessary.

- 1 Cable tie around hose **B** and hose **G**

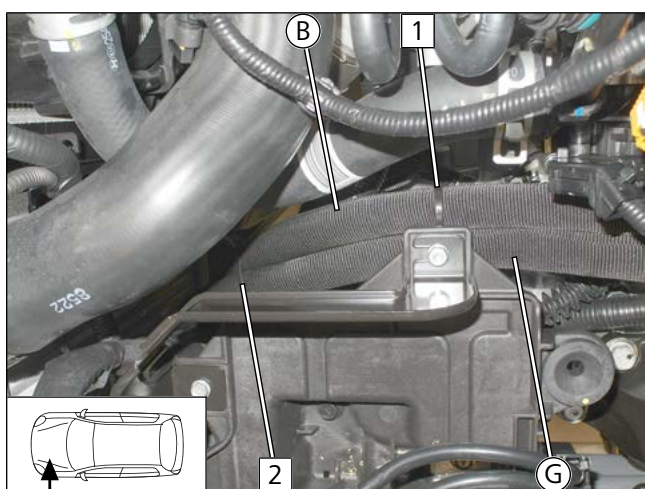

Fig. 83



Danger of damage to components

► Ensure sufficient distance from neighbouring components, correct if necessary.

- 1 Tighten cable tie
- 2 Cable tie around hose **B** and hose **G**



Fig. 84



Danger of damage to components

► Ensure sufficient distance from neighbouring components, correct if necessary.

- 1 Cable tie around hose **B**, hose **G** and original vehicle wiring harness



## 12 Coolant for 2.0 CRDi

### 12.1 Hose routing diagram

'Inline' coolant circuit

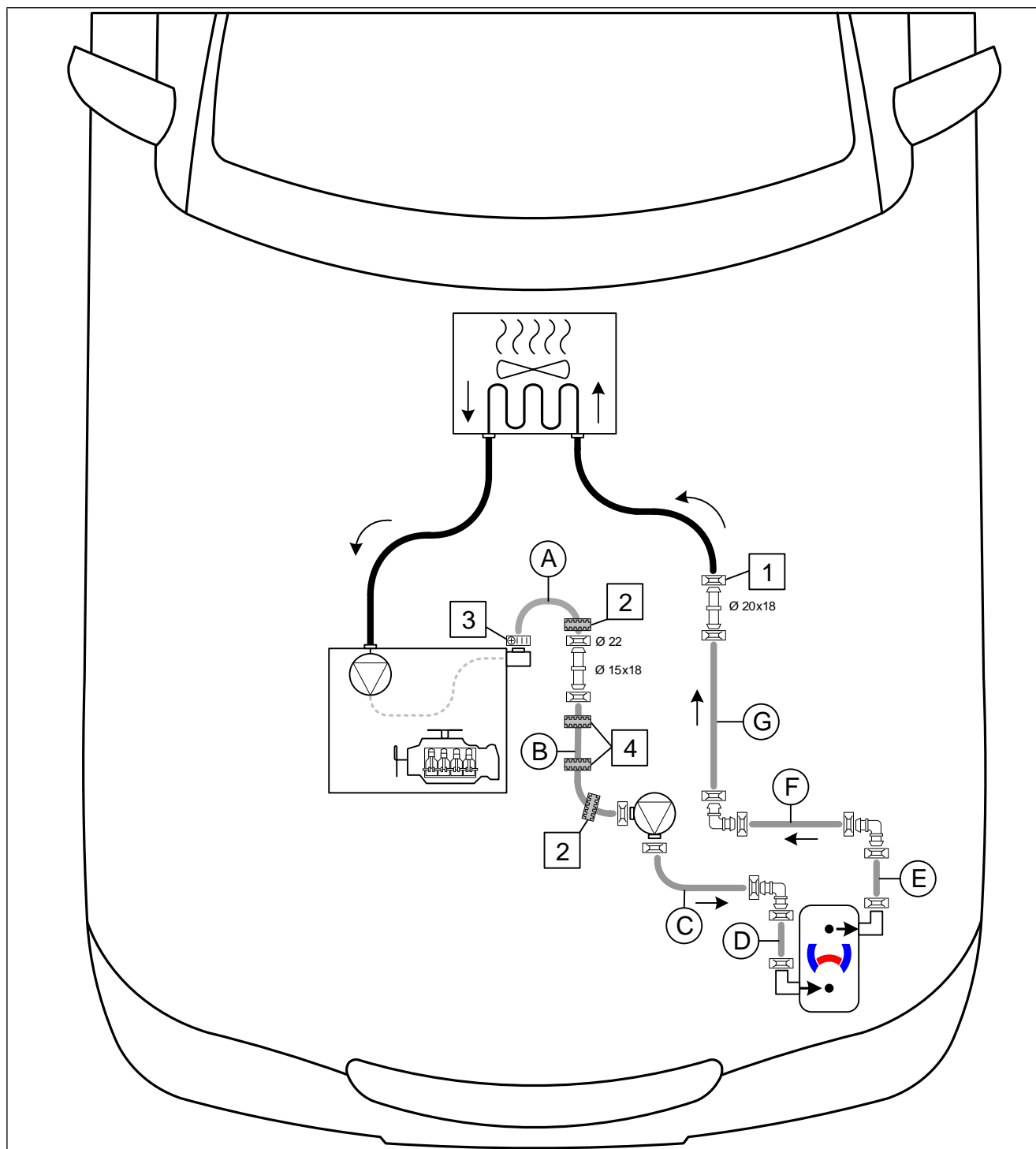



Fig. 85

All spring clips without a specific designation  = Ø25

All connecting pipes without a specific designation  = Ø18x18

**1** Original vehicle spring clip; **2** Ø22, black rubber isolator; **3** Ø16-27 hose clip;

**4** Ø25, black rubber isolator





## 12.2 Preliminary Work

### Preparing coolant pump mount

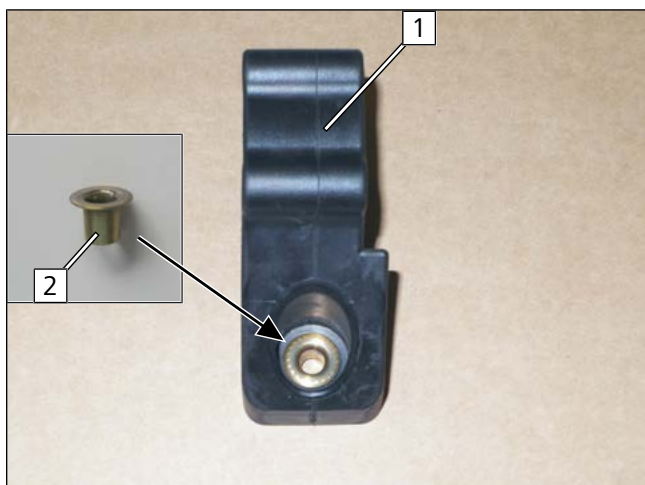

Fig. 86

- 1 Coolant pump mount
- 2 Sleeve

### Premounting coolant pump

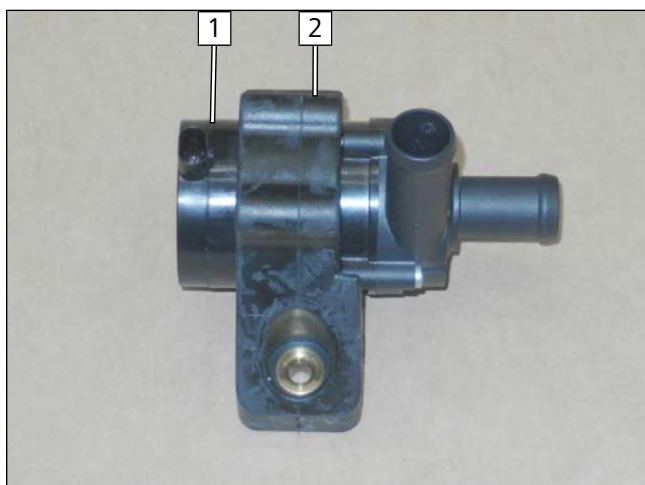

Fig. 87

- 1 Coolant pump
- 2 Coolant pump mount

### Drilling hole and inserting rivet nut

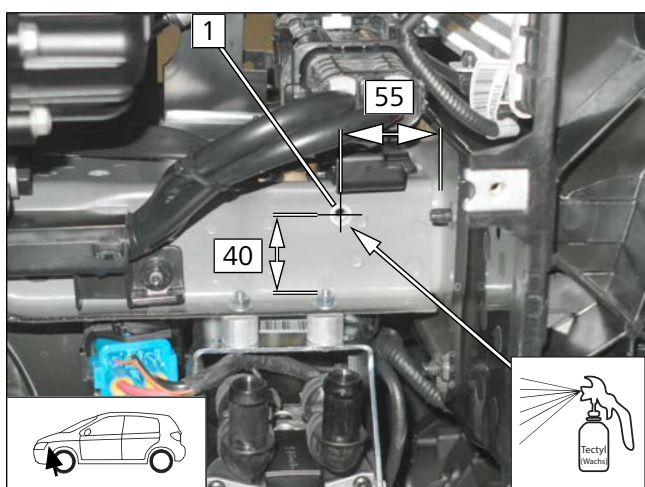
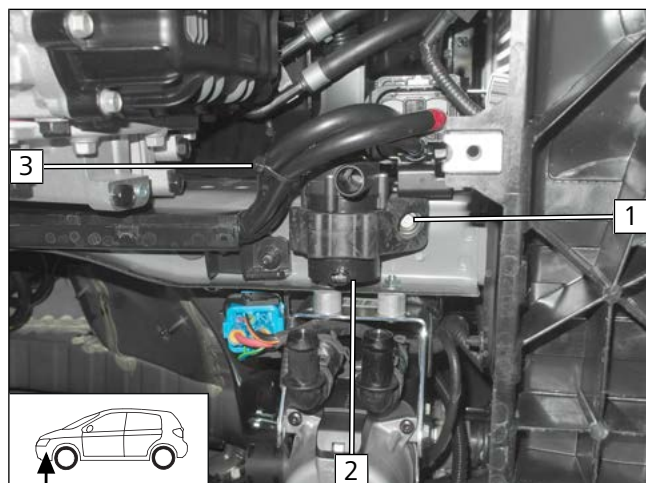

Fig. 88

- 1  $\varnothing 9$  hole, rivet nut



## Mounting coolant pump



- 1 M6x25 bolt
- 2 Coolant pump
- 3 Cable tie

Fig. 89

## Mounting coolant pump wiring harness

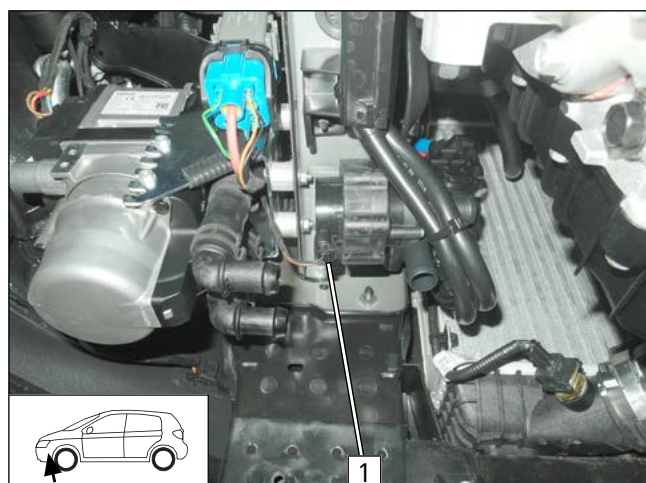

- 1 Coolant pump wiring harness

Fig. 90

## Mounting fabric heat shrink tubings and rubber isolators

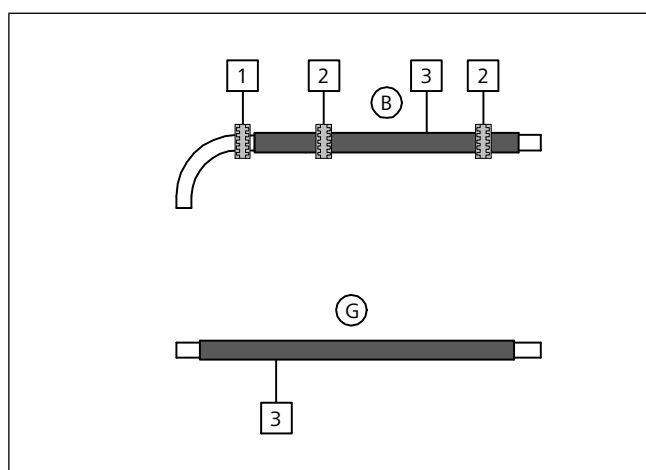

► Push fabric heat shrink tubings **3** onto hoses **B** and **G**, cut to length and shrink.

- 1 Ø22 rubber isolator
- 2 Ø25 rubber isolator

Fig. 91



## Mounting heat protection hose

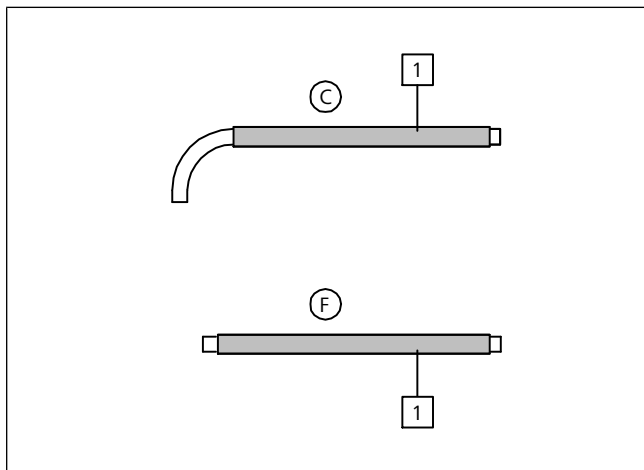

Fig. 92

- Cut heat protection hose **1** to length and push onto hoses **C** and **F**.

## Premounting hose **A**

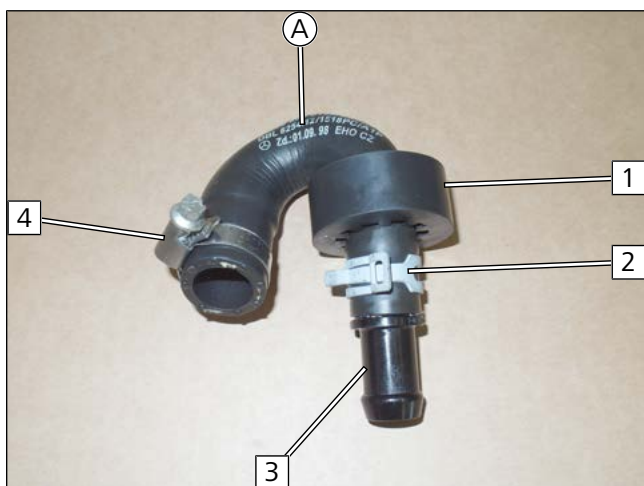

Fig. 93

- 1** Black (sw), Ø22 rubber isolator
- 2** Ø22 spring clip
- 3** Ø15x18 connecting pipe
- 4** Ø16-27 hose clip

## 12.3 Coolant circuit installation

### Cutting point

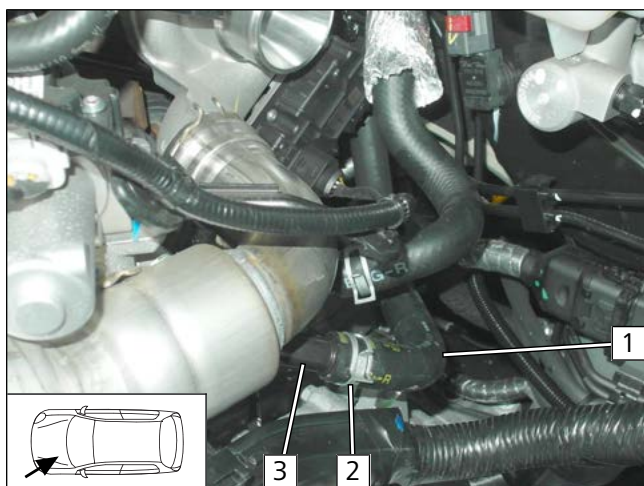

Fig. 94

- Remove engine outlet / heat exchanger inlet hose **1** from engine outlet connection piece **3**. Original vehicle spring clip **2** will be reused.



## Premounting engine outlet and heat exchanger inlet hose section

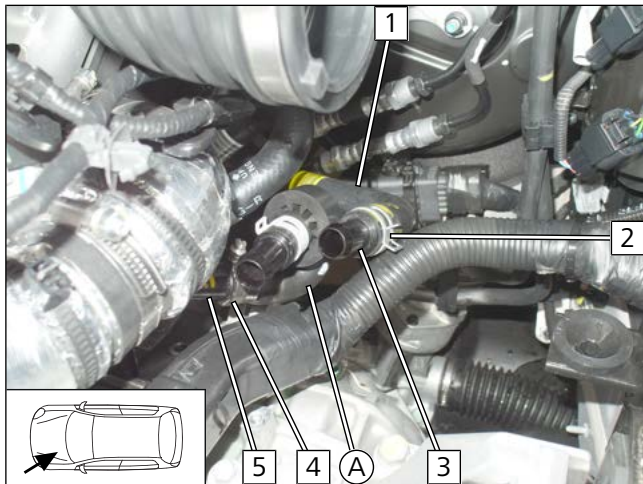

Fig. 95

## Heater outlet connection

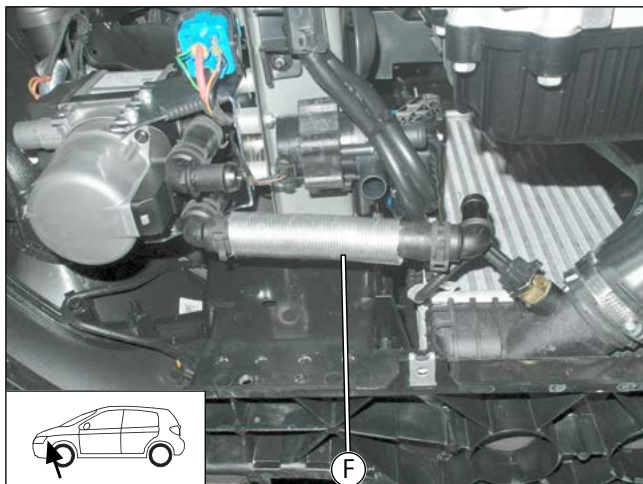

Fig. 96

## Heater inlet and coolant pump outlet connection

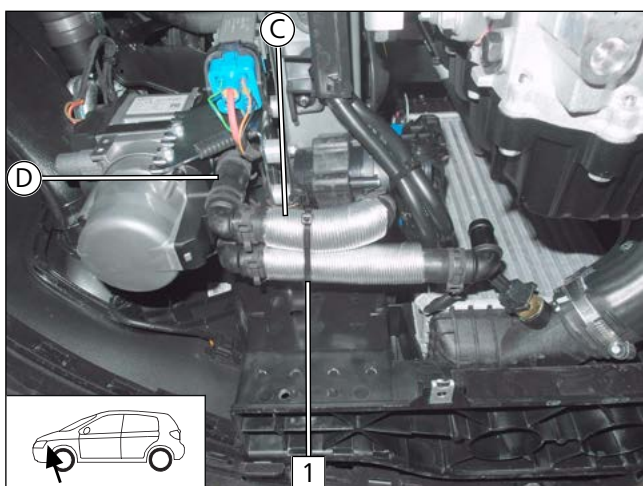

Fig. 97

- 1 Heat exchanger inlet hose section
- 2 Original vehicle spring clip
- 3 20x18 connecting pipe
- 4 Ø16-27 hose clip
- 5 Engine outlet connection piece

- 1 Cable tie





### Connection of hose **B** to hose **A**

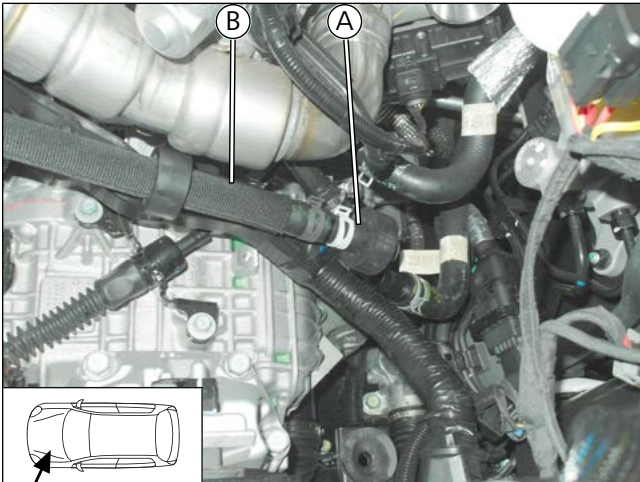

Fig. 98

### Heat exchanger inlet connection

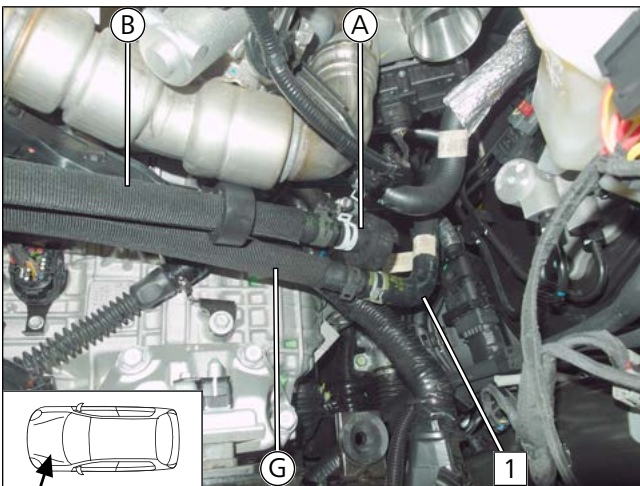

Fig. 99

- 1 Heat exchanger inlet hose section

### Preparing perforated bracket

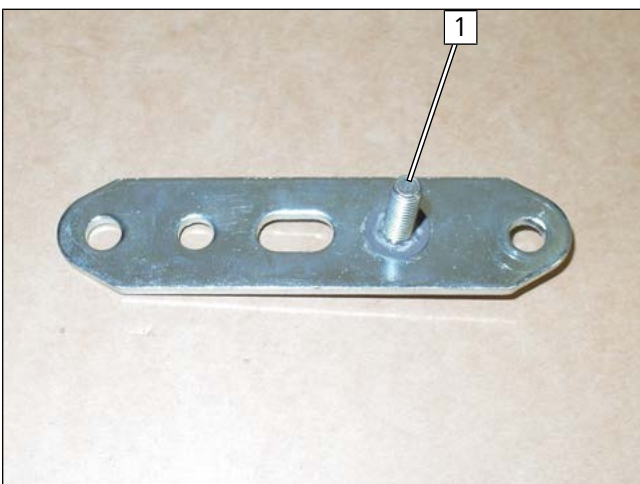

Fig. 100

- 1 M6x20 bolt, perforated bracket, lock washer





## Routing hoses **B** and **G**

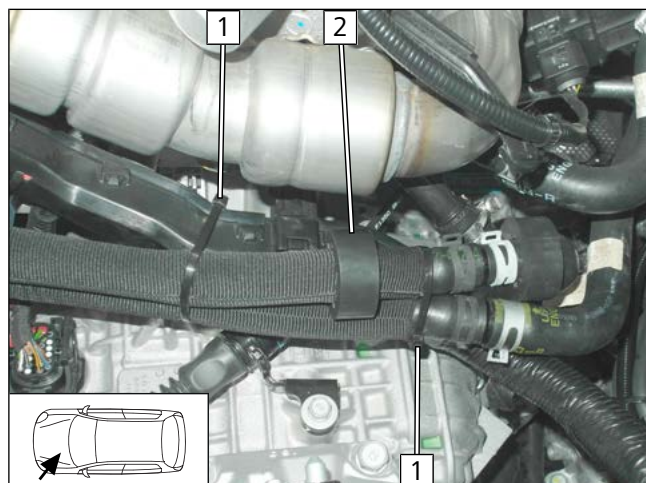

Fig. 101



Danger of damage to components

► Ensure sufficient distance from neighbouring components, correct if necessary.

- 1 Cable tie
- 2 Position black (sw) rubber isolator

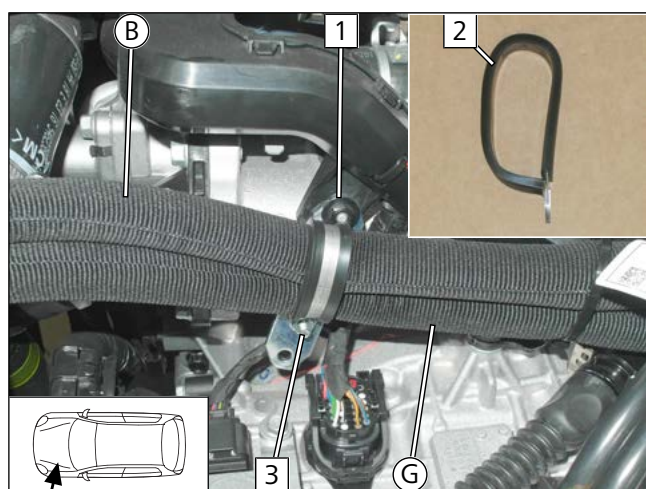

Fig. 102

► Shape Ø38 rubber-coated p-clamp **2** as shown.

- 1 Original vehicle nut
- 3 Prepared perforated bracket, Ø38 rubber-coated p-clamp, flanged nut

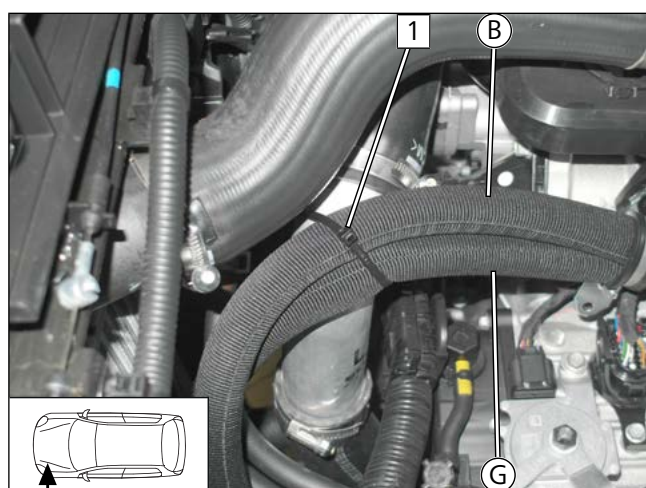

Fig. 103

- 1 Cable tie



## Aligning rubber isolator

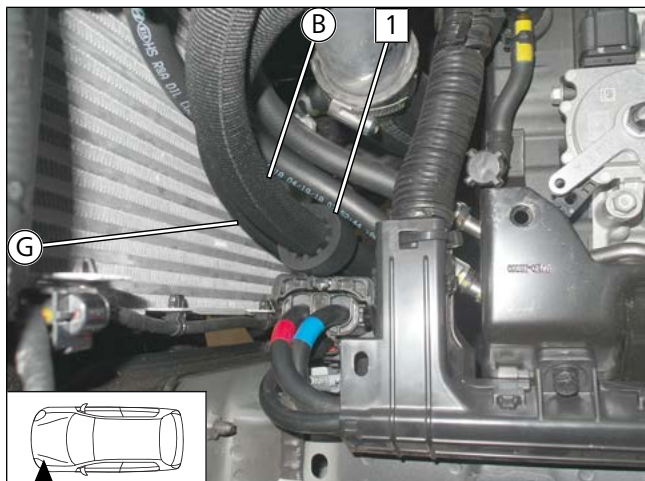

Fig. 104



Danger of damage to components

► Ensure sufficient distance from neighbouring components, correct if necessary.

- 1 Black (sw) rubber isolator

## Connecting hoses **B** and **G**

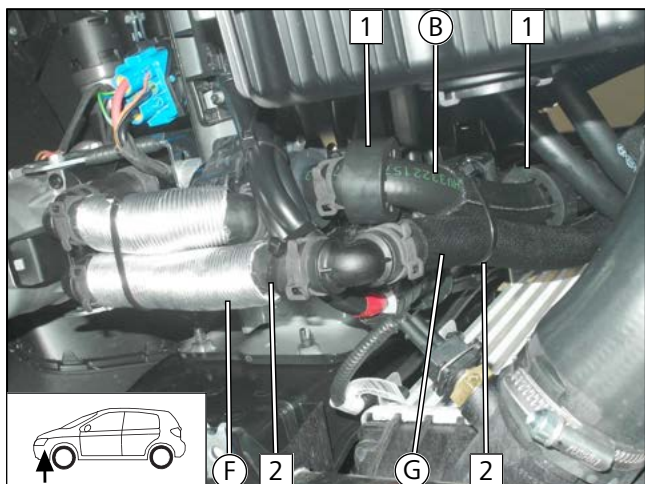

Fig. 105

- 1 Aligning black (sw) rubber isolator
- 2 Cable tie



## 13 Exhaust

### 13.1 Mounting exhaust pipe

Cutting exhaust pipe to length

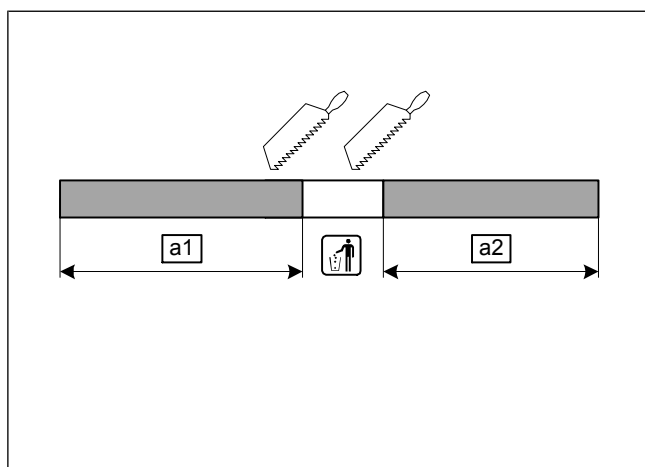

**a1** 280

**a2** 250

Fig. 106

Preparing perforated bracket

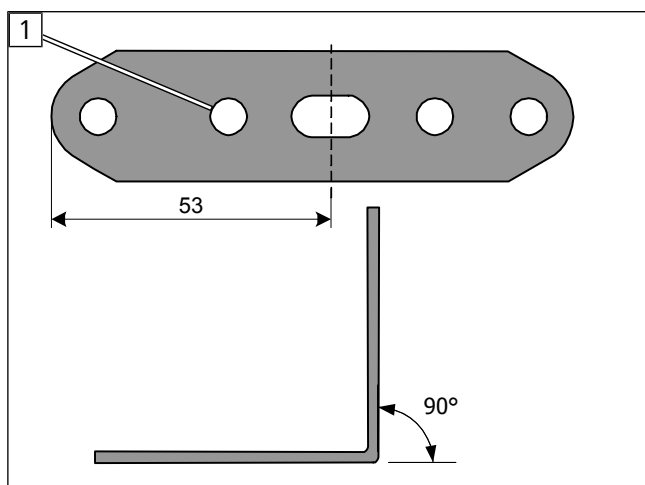

**1** Exhaust silencer fixing point

Fig. 107

Premounting exhaust silencer

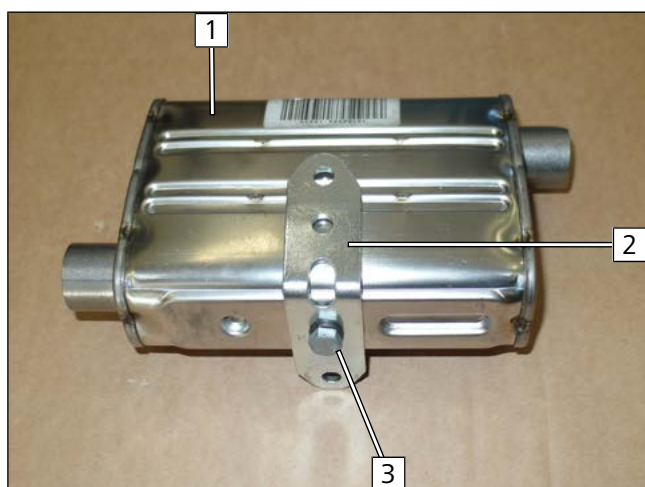

**1** Exhaust silencer

**2** Perforated bracket

**3** M6x16 bolt, spring lockwasher

Fig. 108



### Affixing heat protection film

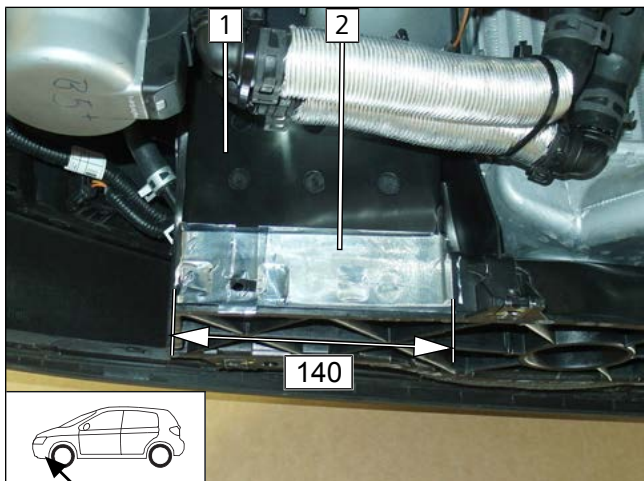

- 1 Radiator cross member
- 2 Heat protection film

Fig. 109

### Mounting exhaust silencer

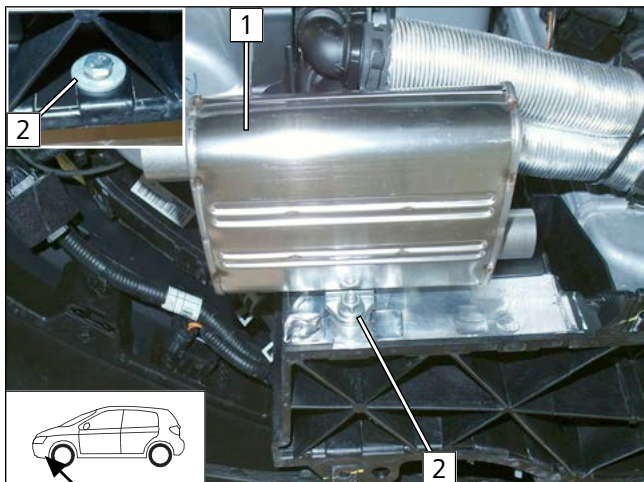

- 1 Exhaust silencer
- 2 M6x30 bolt, large diameter washer, hole, distance washer (10), perforated bracket, flanged nut

Fig. 110

### Mounting exhaust pipe a1



- 1 Hose clamp
- 2 Exhaust silencer

Fig. 111





## Mounting exhaust pipe **a2**

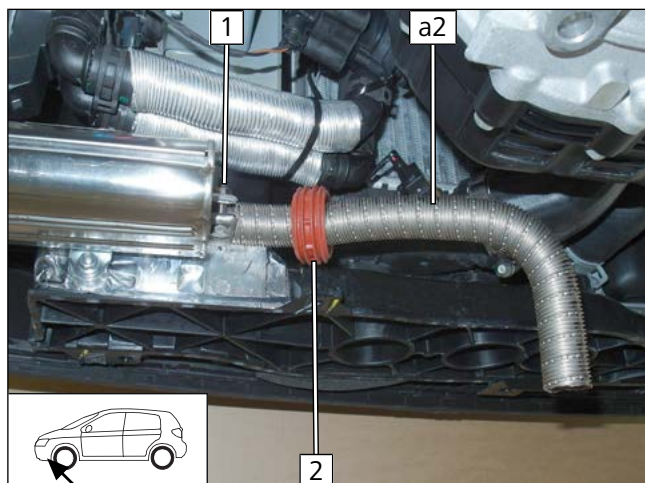

Fig. 112

- 1 Hose clamp
- 2 Slide on spacer bracket

## Aligning exhaust pipe

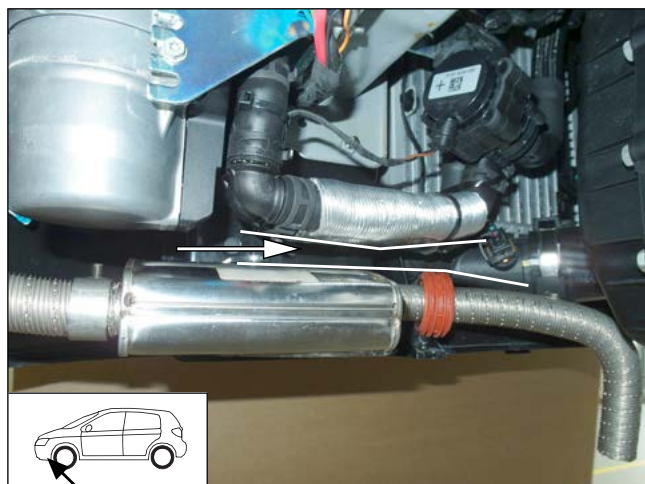

Fig. 113



Ensure sufficient distance from neighbouring components, correct if necessary.



## 13.2 Mounting exhaust end fastener

### Work step E1

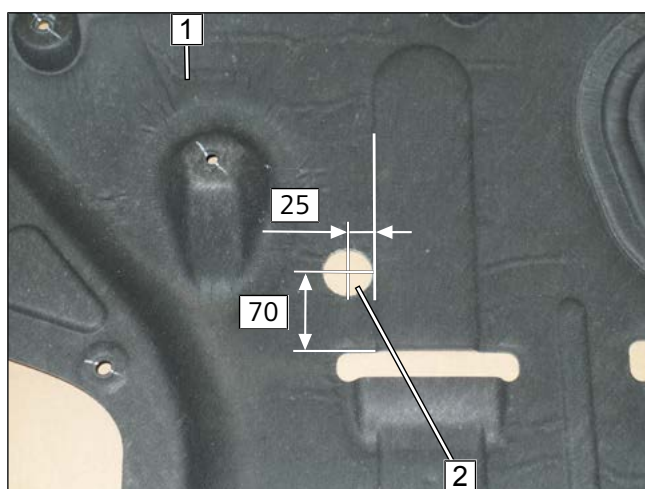

Fig. 114



Observe the EFIX installation instructions.

► Drill hole in underbody protection.

- 1 Underbody protection
- 2 Copy hole pattern, hole





### Work step E3



Fig. 115

► Copy hole pattern.

- 1 EFIX
- 2 Hole pattern

### Work step E4

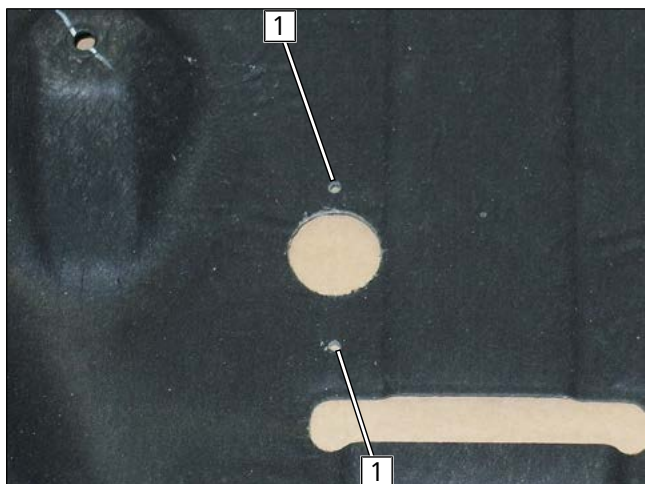

Fig. 116

► Drill holes in underside protection.

- 1 Hole

### Work step E5

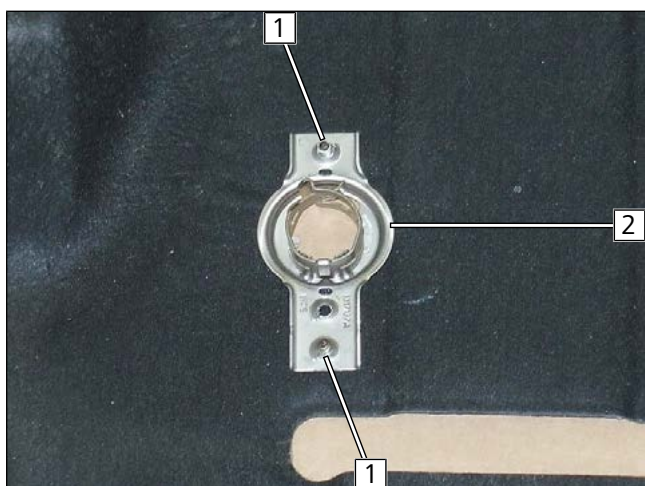

Fig. 117

► Mount exhaust end fastener.

- 1 5x13 self-tapping screw
- 2 EFIX



Work steps E6-E8

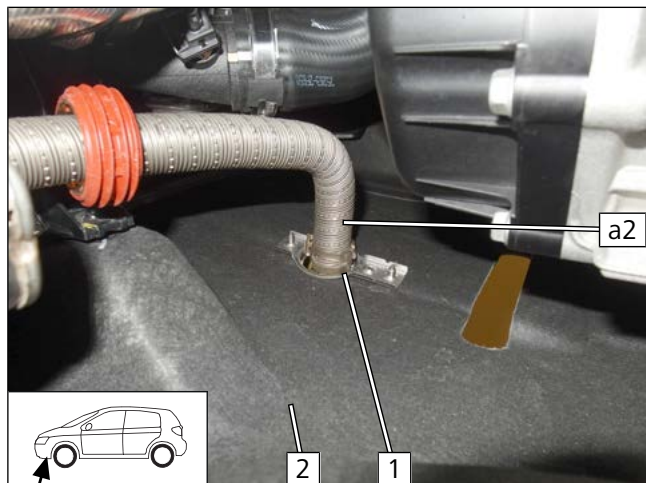

► Mount exhaust pipe **a2**.

- 1** EFIX
- 2** Underride protection

Fig. 118



## 14 Electrical system of passenger compartment

### 14.1 Electrical system preparation

Preparing / assigning wires

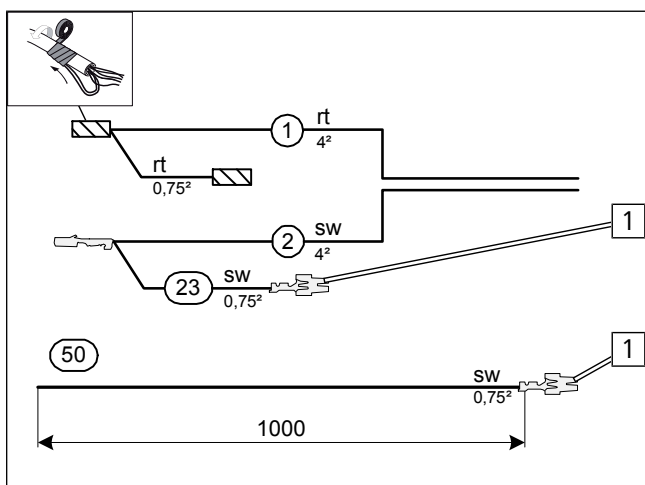

Fig. 119



Wire sections retain their numbering in the entire document.

- 1 Flat spring contact
- 1 Red (rt) wire of fan wiring harness
- 2 Black (sw) wire of fan wiring harness
- 50 Black (sw) wire for additional line

Connecting wires to RSH

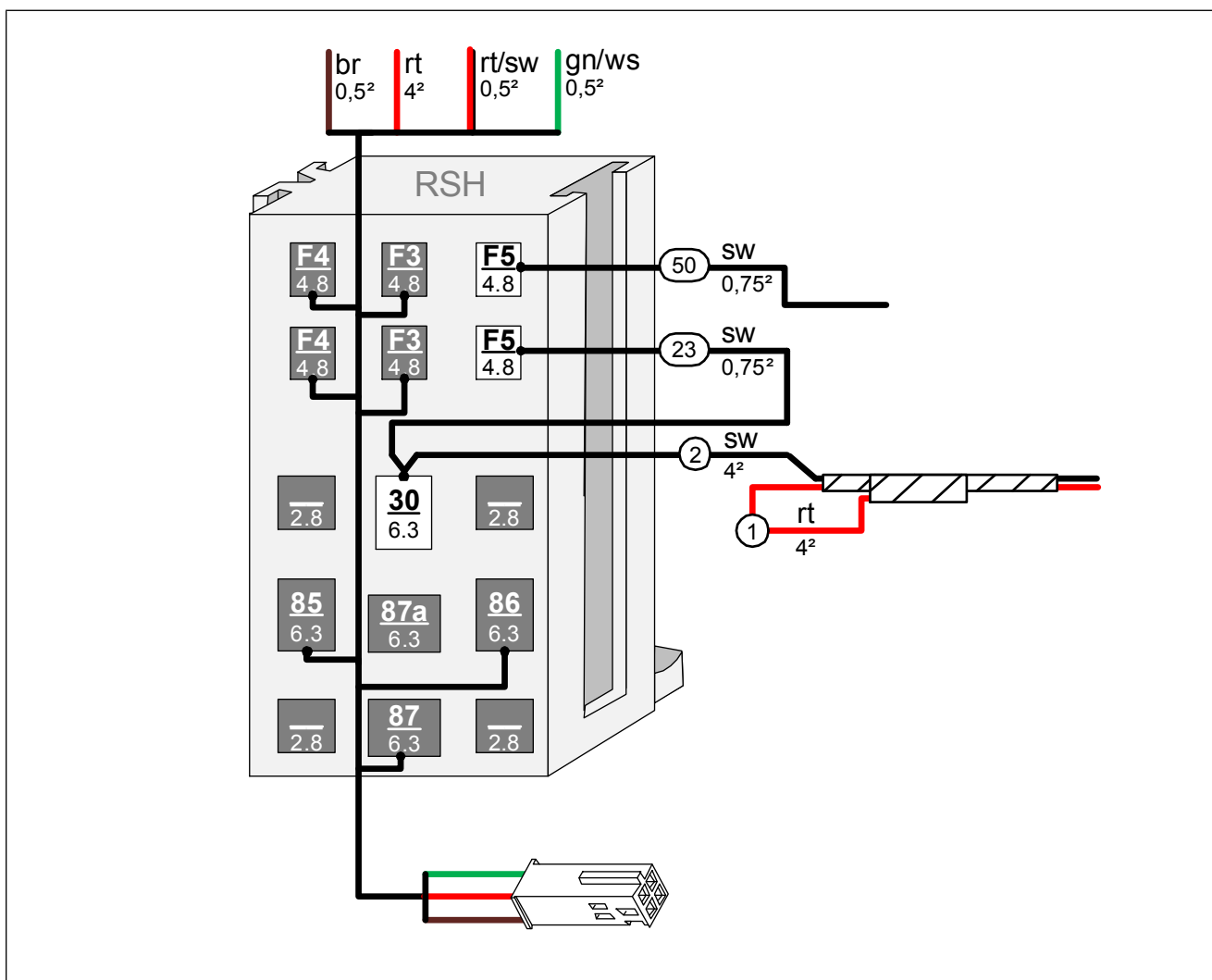

Fig. 120



## Premounting RSH

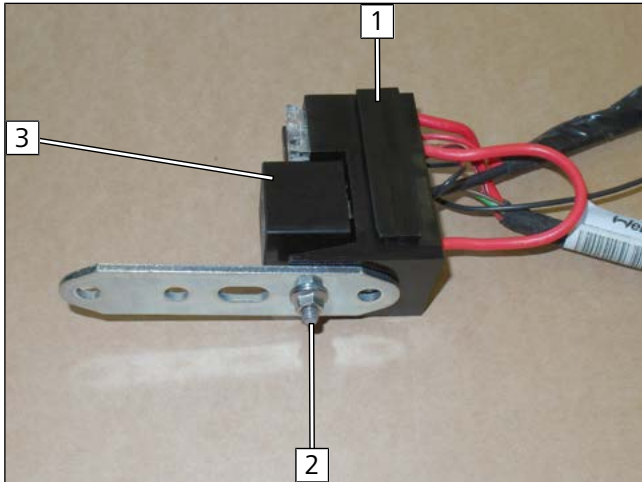

Fig. 121

- 1 RSH
- 2 Mount M5x16 bolt, large diameter washer, RSH, perforated bracket, large diameter washer, nut loosely
- 3 Relay K1

## 14.2 A/C control panel dismantling instructions for Hyundai Tucson

### Detaching switch unit



Fig. 122

- 1 Switch unit
- O Attachment points

### Disconnecting switch unit

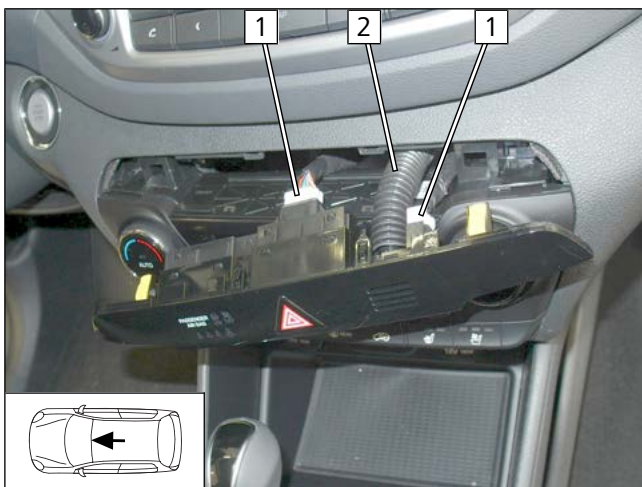

Fig. 123

- 1 Pull off original vehicle connector
- 2 Pull off original vehicle hose



## Removing bolts and detaching A/C control panel

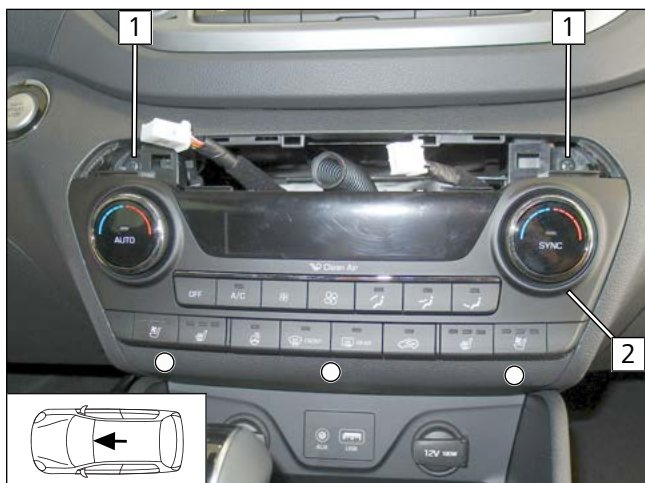

Fig. 124

- 1 Original vehicle bolt
- 2 A/C control panel
- Attachment points

## 14.3 A/C control panel dismantling instructions for Kia Sportage

### Detaching centre console trim

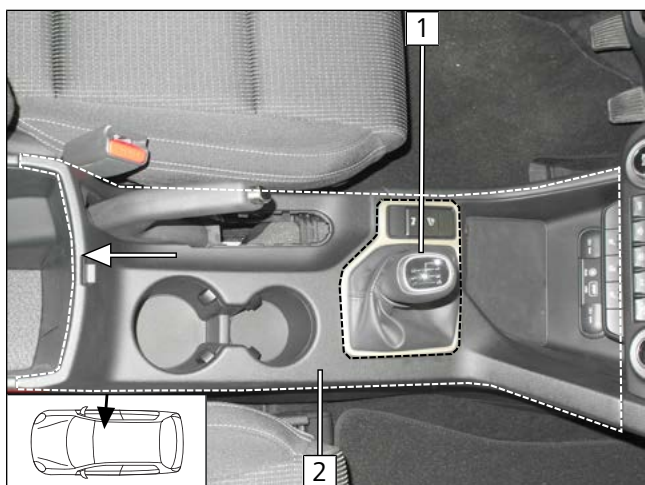

Fig. 125

- 1 Gear knob with trim
- 2 Centre console trim

### Dismantling instrument panel trim

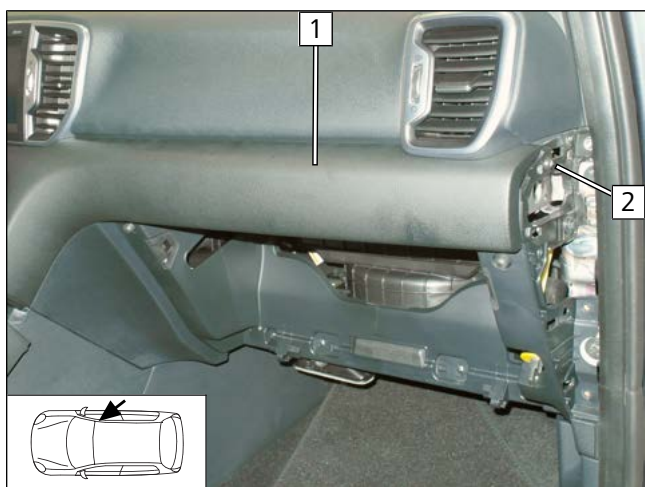

Fig. 126

- ▶ Remove cross-head screw 2 and pull off instrument panel trim 1.





### Dismantling glove box, detaching glove box bracket

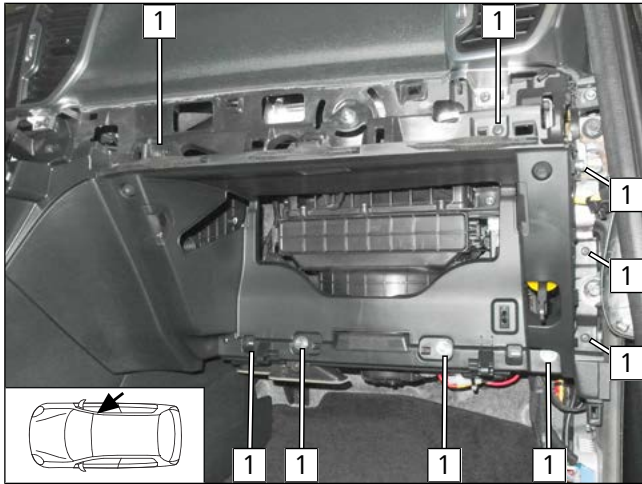

**1** Original vehicle bolt

Fig. 127

### Removing the A/C control panel

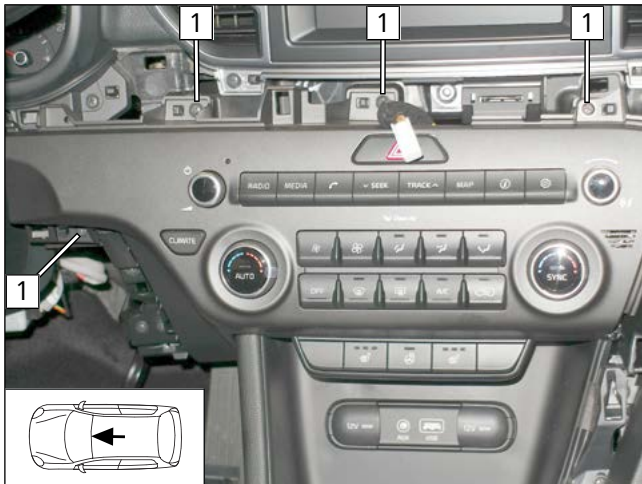

**1** Original vehicle bolt

Fig. 128



## 14.4 Wiring diagram

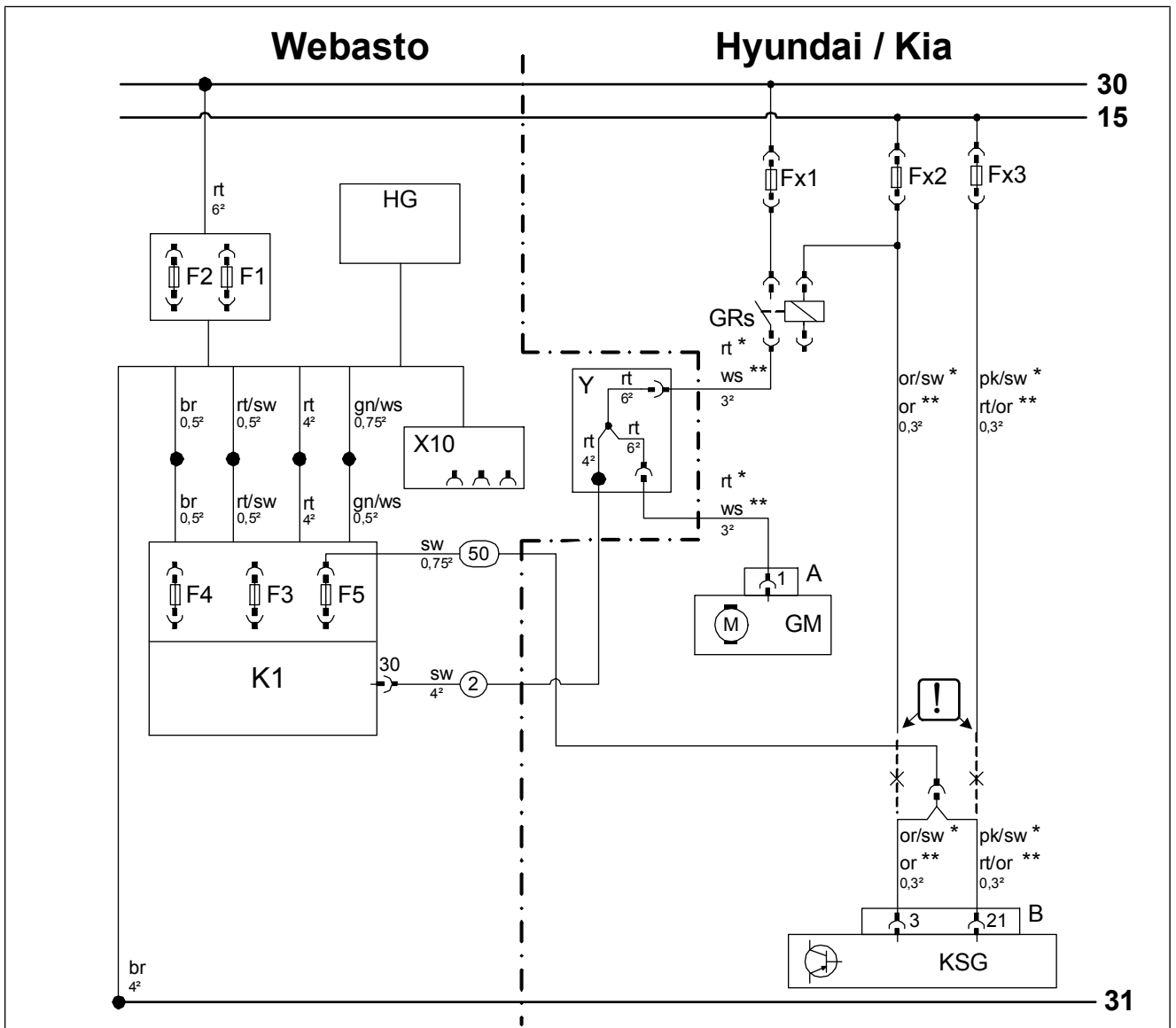

Fig. 129



## Legend to wiring diagram



The vehicle connector and component designations are freely chosen by Webasto.  
Cable colours may vary.

Vehicle components		Symbols	
Abbreviation	Component	Abbreviation	Designation
Fx1	Fuse	X	Cutting point
Fx2	Fuse		insulate and tie back
Fx3	Fuse		
GRs	Fan relay	*	Hyundai Tucson
GM	Fan motor	**	Kia Sportage
A	2-pin GM connector		
KSG	Air-conditioning control unit		
B	40-pin KSG connector		

Webasto components		Cable colours	
Abbreviation	Component	Abbreviation	Colour
A	Male plug for CLR module wiring harness	bg	beige
B	Female plug for CLR module wiring harness	bl	blue
C	Male plug for adapter wiring harness	br	brown
D	Female plug for adapter wiring harness	dbl	dark blue
E	Male plug for Plug&Play wiring harness	dgn	dark green
F	Female plug for Plug&Play wiring harness	ge	yellow
CCL GW	CAN CAN LIN Gateway	gn	green
CL GW	CAN LIN Gateway	gr	grey
CLR	Cold start module	hbl	light blue
D1	Diode	hgn	light green
D2	Diode group	la	salmon
F0	Additional fuse for power supply	or	orange
F1	Heater main fuse	pk	pink
F2	Passenger compartment fan controller main fuse	rt	red
F3	Control element fuse	sw	black
F4	Fan controller fuse	vi	violet
F5	Additional fuse	ws	white
HG	Heater TT-Evo		
K1	Relay K1		
K2	Relay K2		
K3	Relay K3		
LIN GW	LIN Gateway		
PWM GW	Pulse width modulator gateway		
RSH	Relay and fuse holder of passenger compartment		
RTD	Temperature sensor		
X10	Female plug for control element		
Y	Power adapter		



## 14.5 Fan controller

### Mounting RSH

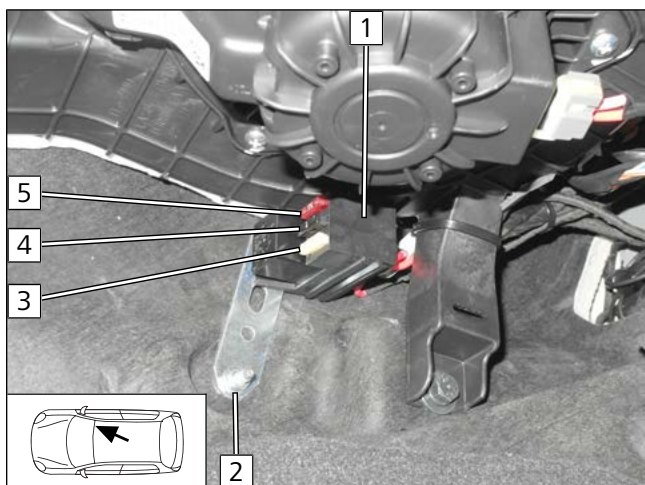

Fig. 130



The system wiring diagram is the basis to make the following electrical connections and for the corresponding cable colours.

- 1 RSH
- 2 Original vehicle stud bolt, perforated bracket, M6 flanged nut
- 3 25A fuse F4
- 4 1A fuse F3
- 5 7.5A fuse F5

### Connecting same colour wires of wiring harnesses

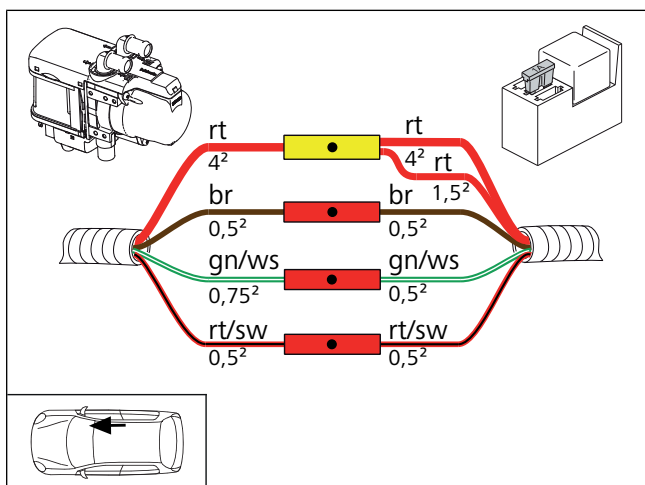

Fig. 131

### Fan motor connection

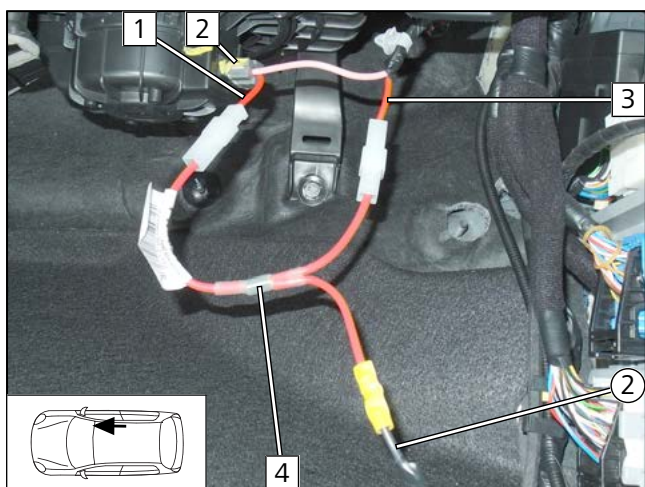

Fig. 132

- 1 Wire of connector A, pin 1
- 2 2-pin connector A of GM
- 3 Wire of original vehicle fan relay
- 4 Y power adapter
- 2 Black (sw) wire of K1/30 fan wiring harness



## Disconnecting connector

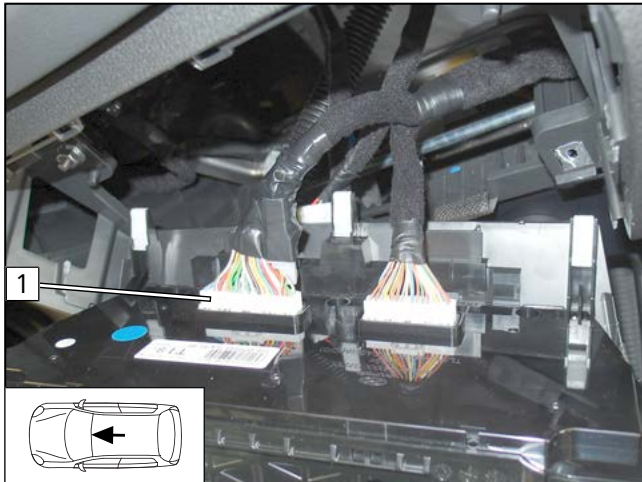

Fig. 133

- 1 40-pin connector B

## View of connector B

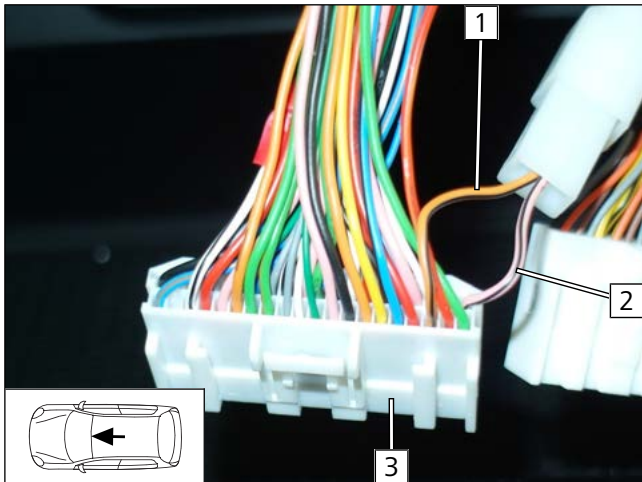

Fig. 134

- 1 Wire, pin 3
- 2 Wire, pin 21
- 3 40-pin KSG connector B

## Connecting KSG

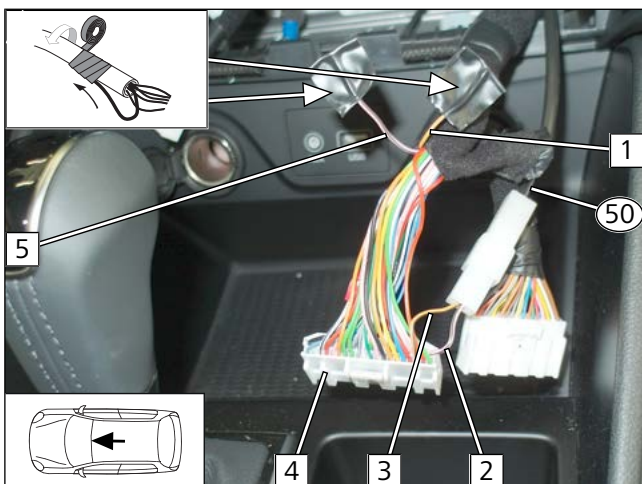

Fig. 135

- 1 Wire of fuse Fx2
- 2 Wire of 40-pin connector B, pin 21
- 3 Wire of 40-pin connector B, pin 3
- 4 40-pin KSG connector B
- 5 Wire of fuse Fx3
- 50 Black (sw) wire of fuse F5





## 15 Electrical system of control elements

### 15.1 MultiControl CAR option

#### Mounting MultiControl CAR

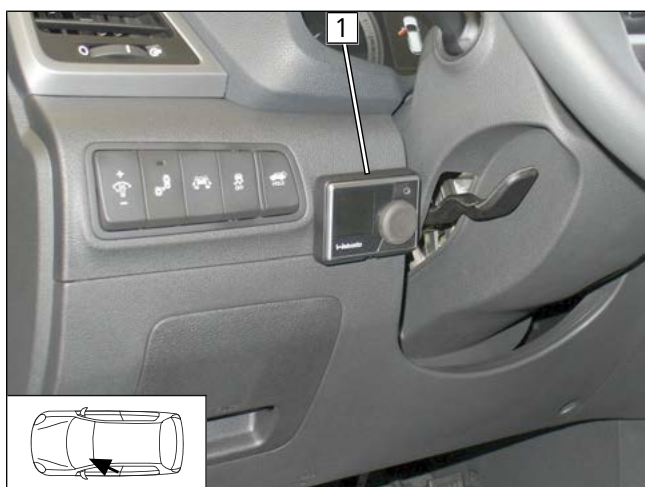

Fig. 136



Observe the MultiControl CAR installation documentation.

- 1 Installation frame

### 15.2 Telestart option

#### Preparing receiver

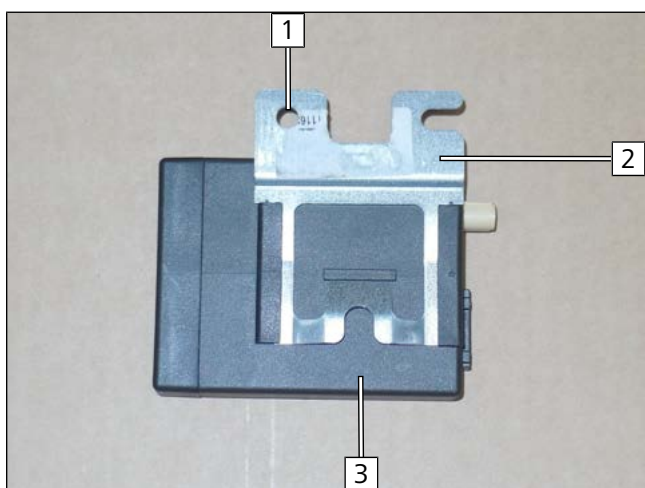

Fig. 137



Observe the Telestart installation documentation.

- 1 Drill out hole to  $\text{Ø}8.5$
- 2 Bracket
- 3 Receiver

#### Mounting receiver

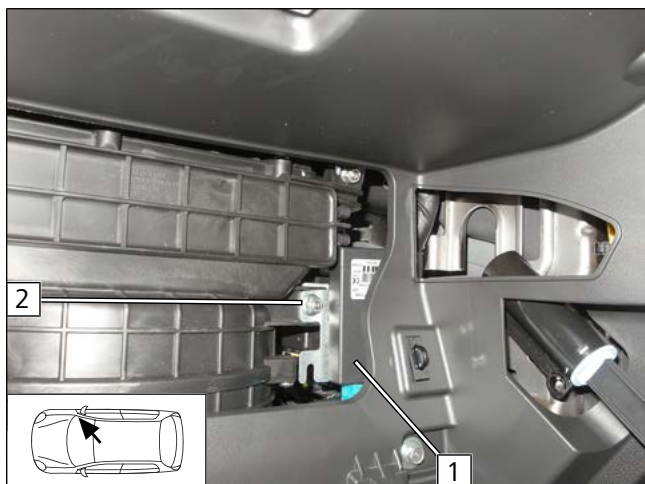
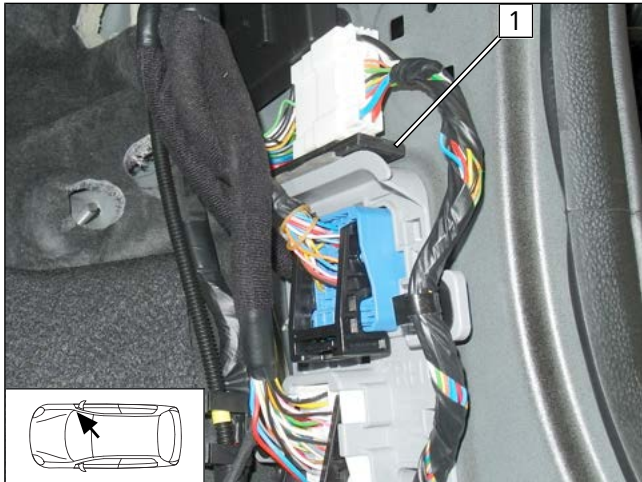

Fig. 138

- 1 Receiver
- 2 Original vehicle nut, receiver bracket



### Mounting temperature sensor, only in case of T100 HTM



► Fasten temperature sensor **1** using double-sided adhesive tape.

Fig. 139

### Mounting aerial

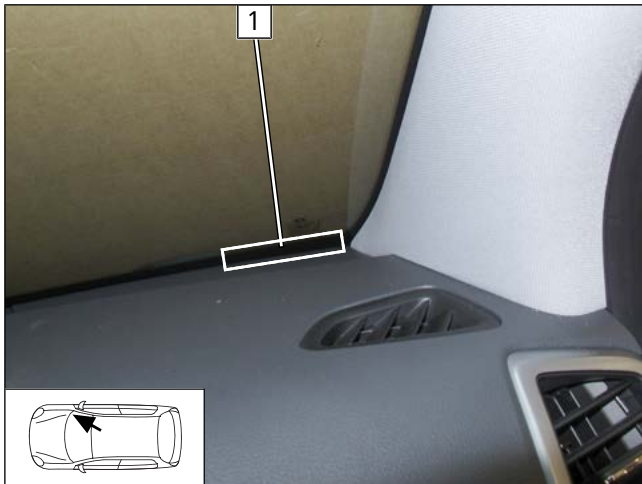

**1** Aerial

Fig. 140

## 15.3 ThermoCall option

### Mounting receiver

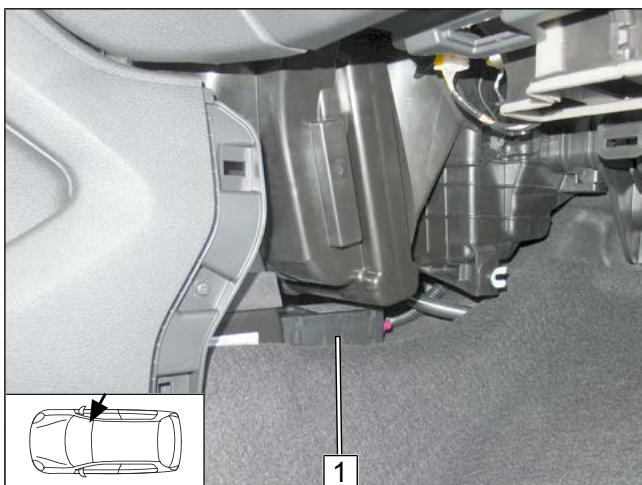

► Fasten receiver **1** using double-sided adhesive tape.

Fig. 141



## Mounting aerial (optional)

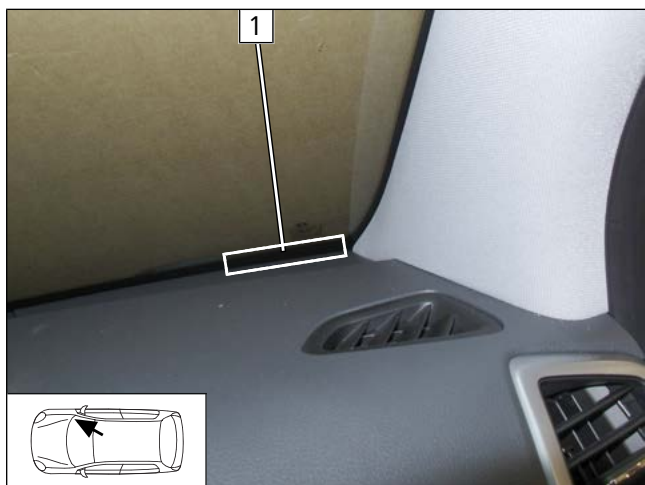

**1** Aerial

*Fig. 142*



## 16 Final Work



Further information can be found in the vehicle manufacturer's technical documentation.

- ▶ Mount removed parts in reverse order.



▶ Check all hoses, clamps and all electrical connections for firm seating.

▶ Insulate and tie back loose lines

▶ Spray heater and electrical components with anti-corrosion wax (Tectyl 100K).

▶ Connect the battery.



**Only use manufacturer-approved coolant.**

- ▶ Fill and bleed the coolant circuit according to the vehicle manufacturer's specifications.



Further information can be found in the general installation and operating instructions of the Webasto components.

▶ Program MultiControl CAR, teach Telestart transmitter

▶ Make settings on A/C control panel according to the 'Operating Instructions'.

▶ Initial operation and functional test

▶ Affix 'Switch off parking heater before refueling' caution label in area of filler neck

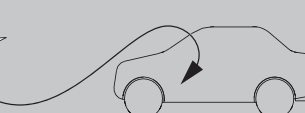
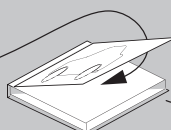
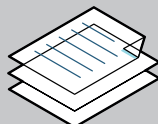





These are the original instructions. The German language is binding.  
You can request your language if it is missing. The telephone number of each country can be found in the Webasto service centre leaflet or the website of the respective Webasto representative of your country.

Webasto Thermo & Comfort SE  
Postfach 1410  
82199 Gilching  
Germany

Company address:  
Friedrichshafener Str. 9  
82205 Gilching  
Germany

Technical Extranet: <https://dealers.webasto.com>



WWW.WEBASTO.COM



## 17 FuelFix template

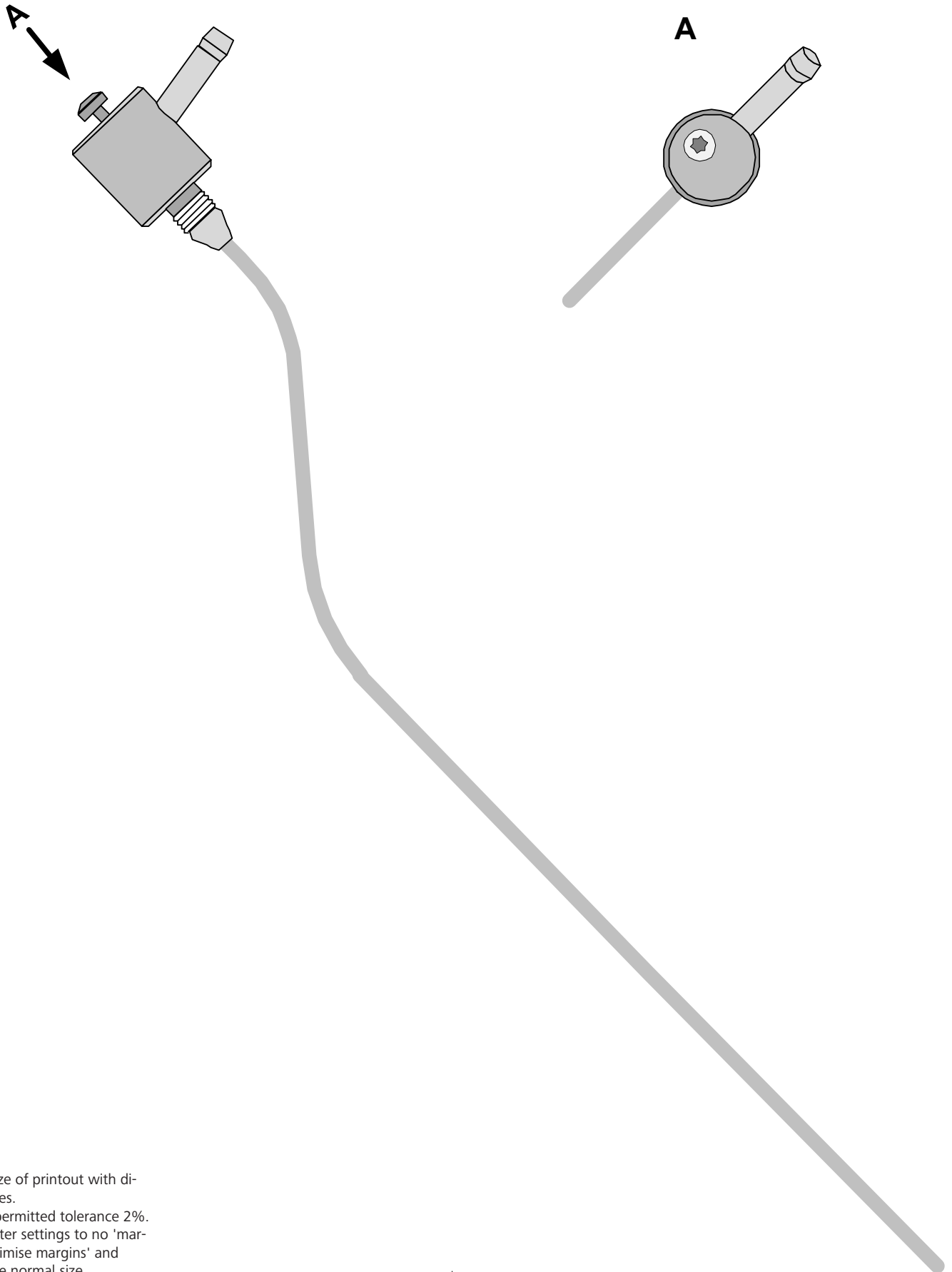

100mm

0

100mm

Scale 1:1  
Compare size of printout with dimension lines.  
Maximum permitted tolerance 2%.  
Set the printer settings to no 'margin' or 'minimise margins' and 100% of the normal size.



## 18 Operating instructions for automatic air-conditioning of Hyundai Tucson



### Information regarding the heating time:

We recommend matching the heating time to the driving time (heating time = driving time)

**Example:** for a driving time of approx. 20 min. (in one direction), we recommend not exceeding a switch-on time of 20 min.



### Vehicles with passenger compartment monitoring:

Further information can be found in the vehicle operating instructions.

- ▶ Deactivate passenger compartment monitoring for the heating operation



### Note for parking heater function

Your vehicle is equipped with a passenger compartment and engine preheating unit.

### 18.1 A/C control panel settings

Automatic A/C control panel



Fig. 143



Before parking the vehicle, make the following settings:

- 1 Temperature on both sides to 'HI'
- 2 Air outlet to windscreen
- 3 Set fan to level '2' to '3'

### 18.2 Installation location of fuses

Fuses in engine compartment

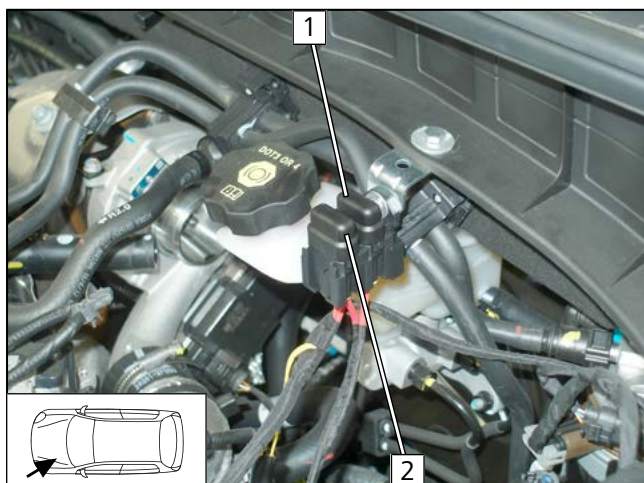
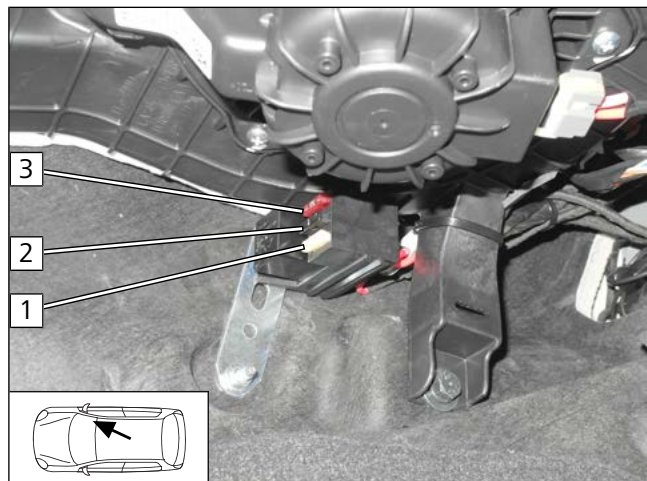

Fig. 144

- 1 F2 - 30A main fuse of passenger compartment
- 2 F1 - 20A heater fuse

## Fuses in passenger compartment



- 1 F4 - 25A fan fuse
- 2 F3 - 1A control element fuse
- 3 F5 - 7.5A A/C control panel fuse

Fig. 145



## 19 Operating instructions for automatic air-conditioning of Kia Sportage



### Information regarding the heating time:

We recommend matching the heating time to the driving time (heating time = driving time)

**Example:** for a driving time of approx. 20 min. (in one direction), we recommend not exceeding a switch-on time of 20 min.



### Vehicles with passenger compartment monitoring:

Further information can be found in the vehicle operating instructions.

► Deactivate passenger compartment monitoring for the heating operation



### Note for parking heater function

Your vehicle is equipped with a passenger compartment and engine preheating unit.

### 19.1 A/C control panel settings

#### Automatic A/C control panel

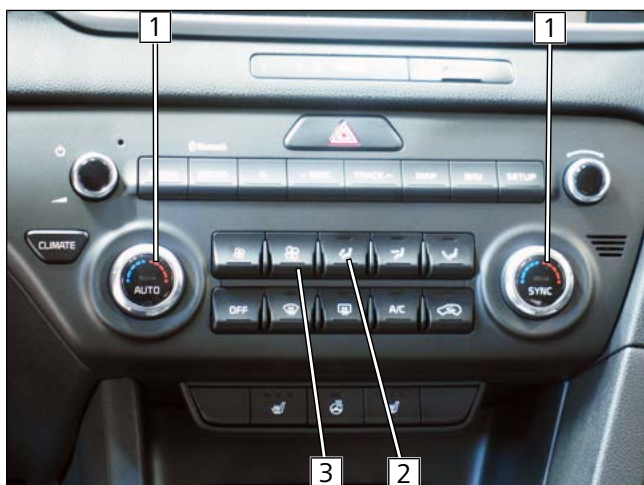

Fig. 146



Before parking the vehicle, make the following settings:

- 1 Temperature on both sides to 'HI'
- 2 Air outlet to windscreen
- 3 Set fan to level '2' to '3'

### 19.2 Installation location of fuses

#### Fuses in engine compartment

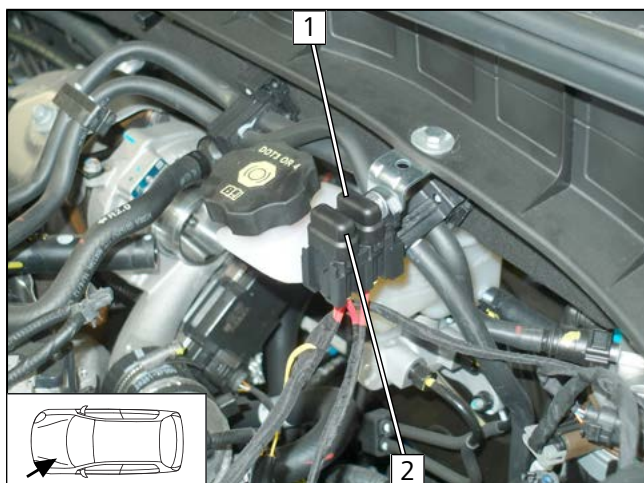
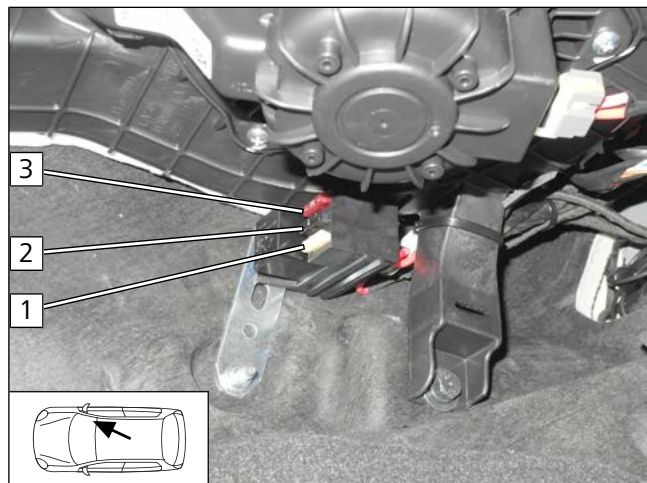

Fig. 147

- 1 F2 - 30A main fuse of passenger compartment
- 2 F1 - 20A heater fuse

## Fuses in passenger compartment



- 1 F4 - 25A fan fuse
- 2 F3 - 1A control element fuse
- 3 F5 - 7.5A A/C control panel fuse

Fig. 148