

K Installation documentation

for water heaters Thermo Top Evo

'Inline' coolant circuit with engine preheating

Audi A6

Left-hand drive vehicle

Manufacturer	Model	Type	Model year	EG-BE-No. / ABE		
Audi	A6	F2	from 2018	e1* 2007/46* 1801*...		
Motorisation	Fuel	Emission standard	Transmission type	Output [kW]	Displacement [cm ³]	Engine code
40 TDI	Diesel	Euro 6d Temp	AG	150	1968	DFBA

Validity	Equipment variants	Model
		A6
Verified equipment variants	Multi-zone automatic air-conditioning	x
	LED main headlights	x
	Headlight washer system	x
	Passenger compartment monitoring	x
	Alarm system	x
	Automatic Start-Stop system	x
	Start button	x
	Keyless Go	x
	AdBlue 24l	x
	73l fuel tank	x
Mild hybrid	x	
Unverified equipment variants	Windscreen heater	x

Total installation time	Note
11 hours	

Contents

1	List of abbreviations	3	14	Electrical system of passenger compartment	41
2	Installation notes	4	14.1	Electrical system preparation	41
2.1	Information on Validity	4	14.2	Installation of CCL with Telestart option	45
2.2	Components used	4	14.3	Installation of CCL with ThermoCall option	47
2.3	Notes on installation, in coordination with the end customer	4	14.4	Wiring diagram	49
2.4	Information on Total Installation Time	4	14.5	Fan controller	51
3	About this document	5	15	Final Work	54
3.1	Purpose of the document	5	16	Operating instructions	57
3.2	Warranty and liability	5	16.1	A/C control panel settings	58
3.3	Safety	5	16.2	Installation location of fuses	58
3.4	Using this document	6			
4	Technical Information	7			
5	Preparations	8			
5.1	Vehicle preparation	8			
5.2	Heater preparation	9			
6	Installation overview	10			
7	Electrical system of engine compartment	11			
8	Mechanical system	15			
8.1	Preparing installation location	15			
8.2	Premounting heater	18			
8.3	Heater mounting	20			
9	Combustion air	22			
10	Exhaust	23			
10.1	Mounting exhaust silencer	23			
10.2	Mounting exhaust end fastener	24			
11	Fuel	26			
11.1	Routing fuel line	26			
11.2	Mounting tank extracting device	30			
12	Coolant	33			
12.1	Hose routing diagram	33			
12.2	Coolant circuit preparation	34			
12.3	Coolant circuit installation	36			
13	Final work in engine compartment	40			

1 List of abbreviations

AG	Automatic transmission
CCL	CCL GW
DP	Fuel pump
EFIX	Exhaust end fastener
EPT	Telestart receiver
FF	FuelFix (tank extracting device)
HG	Heater
SH2	Engine compartment fuse holder for F1/F2
UP	Coolant pump
Veh.	Vehicle

2 Installation notes

2.1 Information on Validity

This installation documentation applies to vehicles listed on page 1, assuming technical modifications to the vehicle do not affect installation, any liability claims excluded. Depending on the vehicle version and equipment, modifications may be necessary during installation with respect to this installation documentation. Vehicle and engine types, equipment variants and other specifications not listed in this installation documentation have not been tested. However, installation according to this installation documentation may be possible.

2.2 Components used

Designation	Order number
Basic delivery scope of Thermo Top Evo	In accordance with price list
Installation kit for Audi A6 2018 diesel	1327259B
In case of Telestart, control element, as well as indicator lamp in consultation with end customer	In accordance with price list

2.3 Notes on installation, in coordination with the end customer

- ▶ Arrange for the vehicle to be delivered with the tank only about ¼ full.
- ▶ The installation location of the following elements should be chosen in coordination with the end customer:
 - the push button in case of the Telestart and/or ThermoCall and/or ThermoConnect options
 - the MultiControl CAR option

2.4 Information on Total Installation Time

The total installation time includes the time needed for mounting and demounting the vehicle-specific components, the heater specific installation time and all other times required for the system integration and initial start-up of the heater.

The total installation time may vary for vehicle equipment other than provided.

3 About this document

3.1 Purpose of the document

This installation documentation is part of the product and contains all the information required to ensure professional vehicle specific installation of the:

Thermo Top Evo heater

3.2 Warranty and liability

Webasto shall assume no liability for defects, damage and injuries resulting from a failure to observe the installation, repair and operating instructions of the information contained in them.

This liability exclusion particularly applies to improper installations and repairs by untrained persons or in the case of a failure to use genuine spare parts.

The liability due to culpable disregard to life, limb or health and due to damage or injuries caused by a wilful or reckless breach of duty remain unaffected, as does the obligatory product liability.

Installation should be carried out according to the general, standard rules of technology. Unless specified otherwise, fasten hoses, lines and wiring harnesses to original vehicle lines and wiring harnesses using cable ties. Insulate loose wire ends and tie back. Connectors on electronic components must audibly snap into place during assembly.

Spray unfinished body areas, e.g. drilled holes, with anti-corrosion wax (Tectyl 100K).

Observe the instructions and guidelines of the respective vehicle manufacturer for demounting and mounting vehicle specific components.

The initial start-up is to be executed with the Webasto Thermo Test Diagnosis.

When installing a programmable control module (e.g. a PWM Gateway), the corresponding settings must be checked or adjusted.

3.2.1 Statutory regulations governing installation

The Thermo Top Evo heater has been type-tested and approved in accordance with ECE-R 10 (EMC) and ECE-R 122 (heater). The regulations of these guidelines are binding in the scope of the Directive 70/156/EEC and/or 2007/46/EC (for new vehicle models from 29/04/2009) and should also be observed in countries in which there are no special regulations.

The heater is licensed in accordance with paragraph 19, section 3, No. 2b of the StVZO (German Road Traffic Licensing Authority).

3.3 Safety

Qualifications of installation personnel

The installation personnel must have the following qualifications:

- Successful completion of Webasto training
- Corresponding qualification for working on technical systems

Regulations and legal requirements

The regulations from the heater's general installation and operating instructions must be observed.

3.3.1 Safety information on installation

Danger posed by live parts

- ▶ Prior to installation, disconnect the vehicle from the voltage supply.
- ▶ Make sure the electrical system is earthed correctly.
- ▶ Always comply with legal requirements.
- ▶ Observe data on type label.

Danger of fire and leaking toxic gases due to improper installation

- ▶ Vehicle parts in the vicinity of the heater must be protected against excessive heating by the following measures:
 - ⇒ Maintain minimum safety distances.
 - ⇒ Ensure adequate ventilation.
 - ⇒ Use fire-resistant materials or heat shields.

Danger due to sharp edges

- Lacerations
- Short circuit due to electrical wire damage
- ▶ Fit protectors on sharp edges.

3.4 Using this document

Before installing and operating the heater, read this installation documentation, the installation instructions of the heater, the operating instructions and supplementary sheets provided.

3.4.1 Explanatory Notes on the Document

There is an identification mark near the respective work step to allow you to quickly allocate the other applicable documents to the Webasto components to be installed:

Generally valid Webasto documentation	
Vehicle-specific installation documentation	
Vehicle-specific installation documentation of the cold start kit	
Webasto Comfort A/C control	
Webasto Standard A/C control	
Tank extracting device (e.g. FuelFix)	
Exhaust end fastener (EFIX)	
Combustion air intake silencer	
Spacer bracket (ASH)	

3.4.2 Use of symbols



DANGER

Type and source of the risk

Consequences: Failure to follow the instructions can result in death

► Actions to protect yourself against risks.



WARNING

Type and source of the risk

Consequences: Failure to follow the instructions can lead to serious or even fatal injuries

► Actions to protect yourself against risks.



CAUTION

Type and source of the risk

Consequences: Failure to follow the instructions can lead to minor injuries

► Actions to protect yourself against risks.



Type and source of the risk

Consequences: Failure to follow the instructions can lead to material damage

► Actions to protect yourself against risks.



Reference to the vehicle manufacturer's specific documents.



Note on a special technical feature

3.4.3 Work step identification marks

The ongoing work step is indicated on the outside top corner of the page:

Mechanical system	Electrical system	High-voltage	Coolant
Combustion air	Fuel	Exhaust	Software

3.4.4 Orientation aid

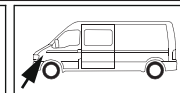
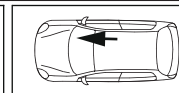

The arrow indicates the position on the vehicle and the viewing angle

3.4.5 Use of highlighting

Highlight	Explanation
✓	Action
►	Necessary action
⇒	Result of an action
1 / 12 / a1	Position numbers for the image descriptions
① / ⑫ / Ⓐ	Position numbers for the image descriptions for electrical wires and components as well as coolant hose sections

4 Technical Information

Dimension specifications

- All dimensions specified in mm
- Perforated brackets and mounting angles are shown to scale
- Observe data regarding scale on the templates

Tightening torque specifications

- Tightening torque values of 5x13 heater bolts and 5x11 heater stud bolts = 8Nm
- Tightening torque values of 5x15 retaining plate of water connection piece bolts = 7Nm
- 5x12 bolt tightening torque of 2-part heater bracket = 6Nm
- Tighten other bolt connections in accordance with manufacturer's instructions or in accordance with state-of-the-art-technology

Temperature specification for heat shrink plastic tubings

- Fabric heat shrink tubing: shrink temperature max. 230°C
- Standard heat shrink plastic tubing: shrink temperature max. 300°C

Necessary special tools

- Hose clamp pliers for auto-tightening hose clamps
- Hose clamp pliers for Clic hose clamps of type W
- Hose clamping pliers
- Hose cutter
- Automatic wire stripper 0.2 - 6 mm²
- Crimping pliers for cable lugs 0.5 – 10 mm²
- Crimping pliers for male connector 0.14 – 6 mm²
- Crimping pliers for connector 0.25 – 6 mm²
- Torque wrench for 2.0 - 10 Nm
- Deep-hole marker
- Metric thread-setter kit
- Webasto Thermo Test Diagnosis with current software

5 Preparations

5.1 Vehicle preparation



Further information can be found in the vehicle manufacturer's technical documentation.

Vehicle area	Components to be removed	Other applicable documents
General	<ul style="list-style-type: none"> ▶ Open the fuel tank cap ▶ Ventilate the fuel tank ▶ Close the fuel tank cap again ▶ Depressurise the cooling system 	
Engine compartment and body	<ul style="list-style-type: none"> ▶ Disconnect the battery (boot) ▶ Battery (water drain chamber) ▶ Complete air filter box ▶ Windscreen wiper ▶ Water drain chamber trim ▶ Front wheel on the front passenger's side ▶ Wheel well interior trim on the front passenger's side ▶ Lower bumper trim on the front passenger's side ▶ Lower engine trim ▶ Underbody trim on the front passenger's side ▶ Tank trim on the front passenger's side 	
Passenger compartment	<ul style="list-style-type: none"> ▶ Side instrument panel trim on the driver's side ▶ Lower instrument panel trim on the driver's side ▶ A-pillar trim on driver's side (only in case of aerial installation) ▶ Footwell trim on the driver's side ▶ Bonnet opener ▶ Entrance strip on the driver's side ▶ Storage compartment on the driver's side ▶ Rear bench seat (attached with clips) 	



Carry out the following work only during the corresponding installation sequence:



DANGER

Risk of fire and explosion due to leaking fuel and escaping fuel vapours.

Vehicle body	<ul style="list-style-type: none"> ▶ Open the tank fitting service lid on the front passenger's side ▶ Detach the tank fitting 	
--------------	--	--

5.2 Heater preparation

Engine compartment	<ul style="list-style-type: none">▶ Remove years that do not apply from the type and duplicate label▶ Attach the duplicate label (type label) in the appropriate place in the engine compartment	
--------------------	---	---

6 Installation overview

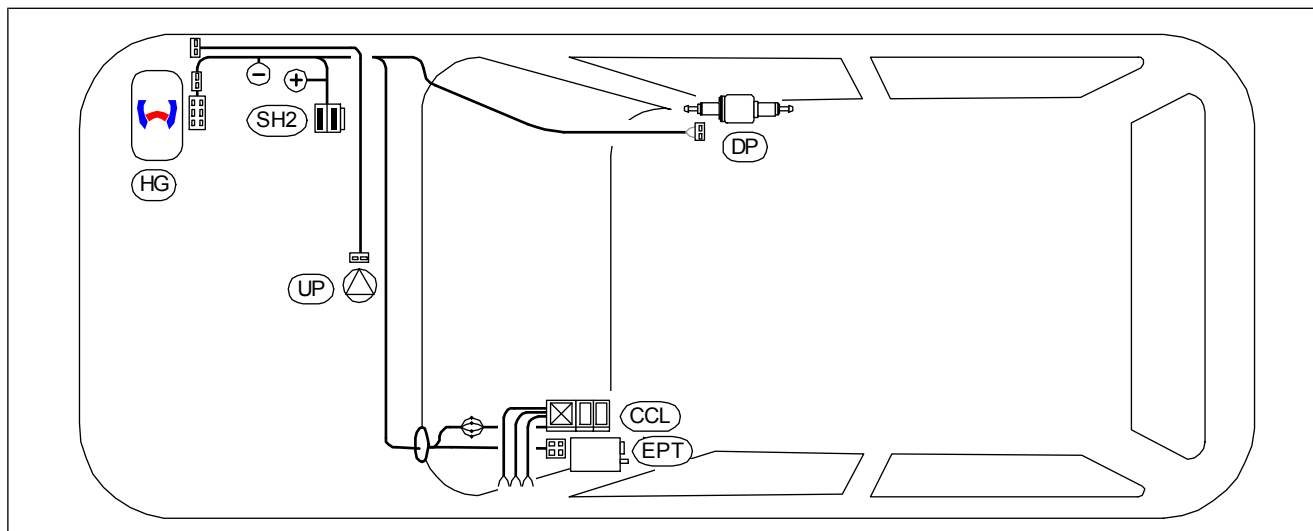
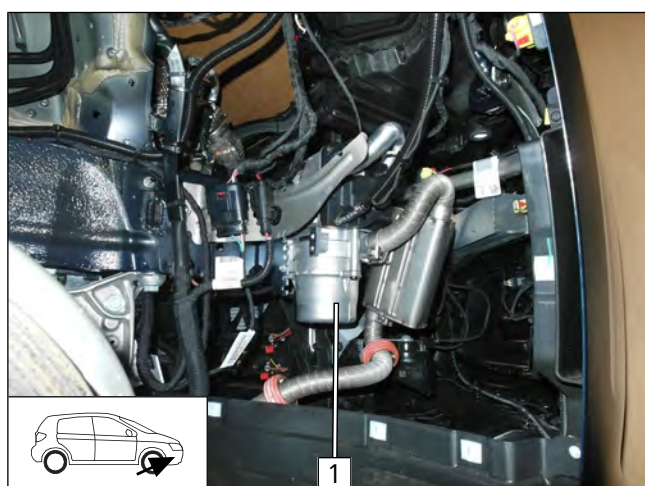

Fig. 1

Legend to installation overview

Abbreviation	Component
CCL	CCL Gateway
DP	Fuel pump
EPT	Telestart receiver
HG	Heater
SH2	Fuse holder of engine compartment
UP	Coolant pump

Heater installation location



1 Heater

Fig. 2



7 Electrical system of engine compartment

Replacing fuse F2

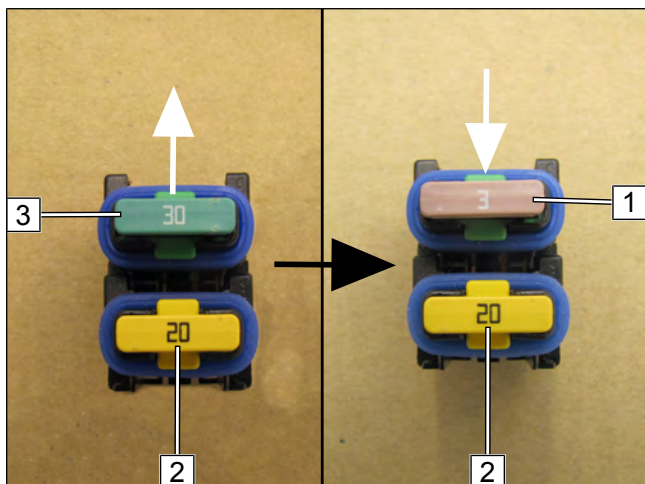

Fig. 3

► Replace 30A passenger compartment main fuse F2 **3** with 3A fuse **1**.

2 Fuse F1: 20A

Premounting retaining plate of SH2

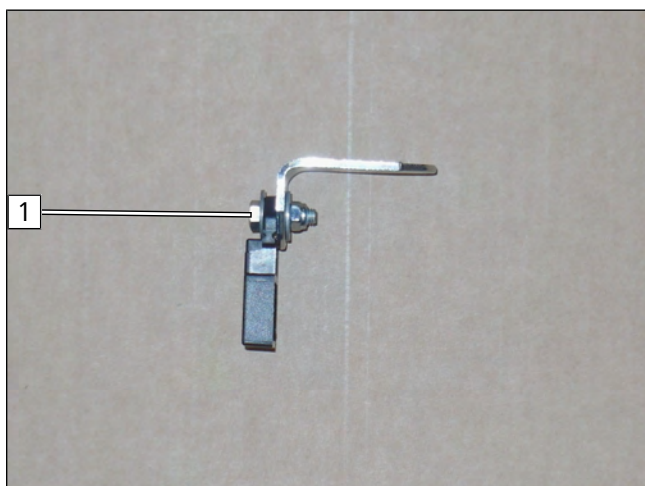

Fig. 4

1 M5x16 bolt, large diameter washer, retaining plate of SH2, angle bracket, large diameter washer, nut

Preparing installation location

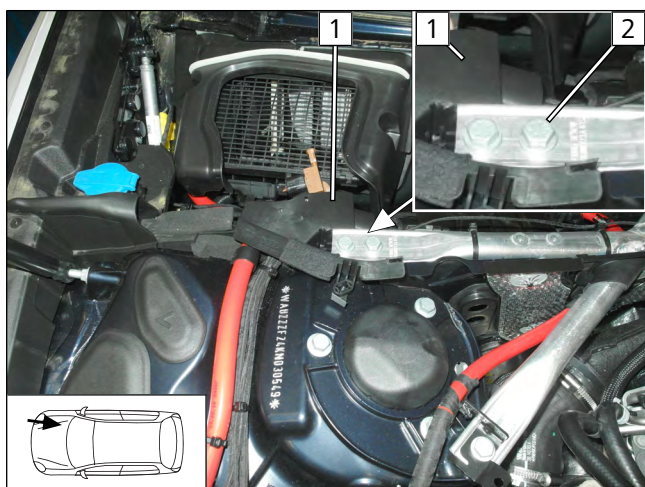

Fig. 5

1 Detach plastic cover
2 Loosen screw



Installing SH2

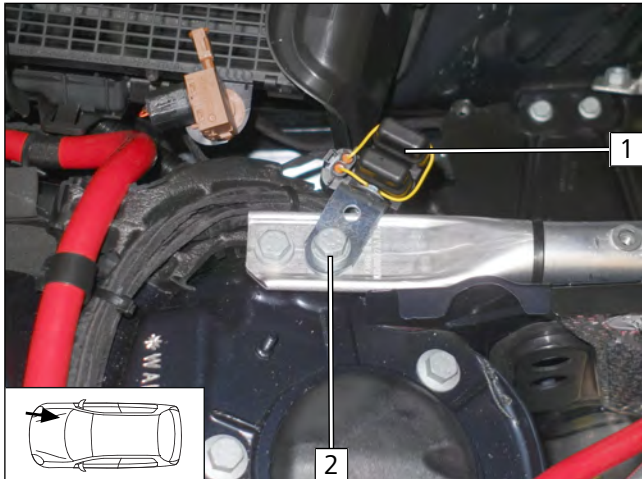

Fig. 6

- 1 Fuses F1 and F2
- 2 Original vehicle bolt, premounted SH2 retaining plate, washer (8), original vehicle strut

Routing wiring harness

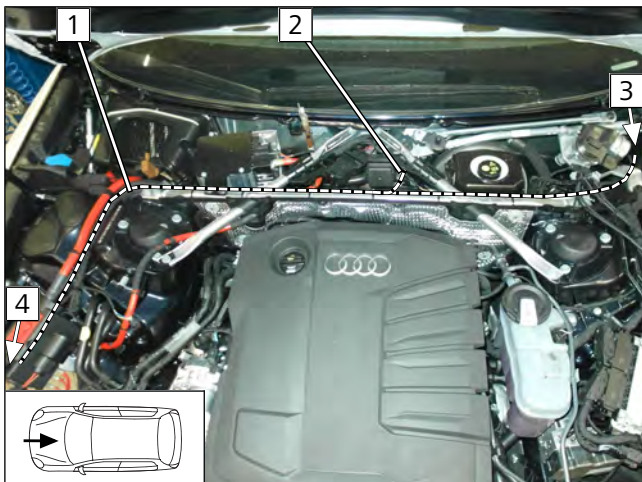

Fig. 7

- ▶ Route heater wiring harness **1** along the original vehicle wiring harness to the installation location of heater **4**.
- ▶ Route coolant pump wiring harness **2** to the coolant pump installation location and the installation location of heater **4**.
- ▶ Route passenger compartment and control element wiring harness to passenger compartment pass through **3** on the driver's side.
- ▶ Fasten wiring harnesses to original vehicle strut using cable ties.

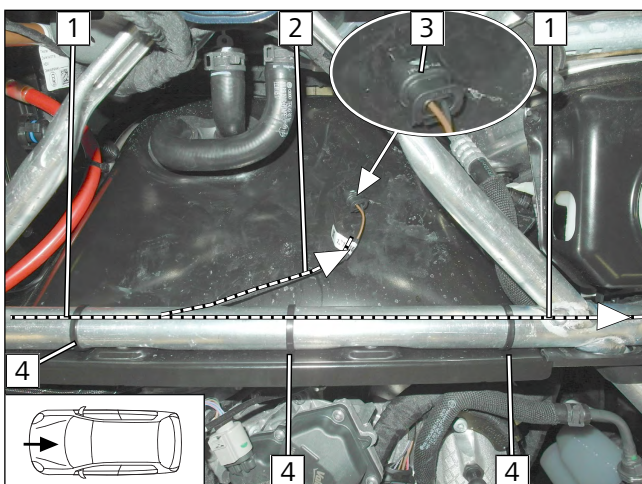

Fig. 8

- 1 Passenger compartment and control element wiring harness
- 2 Coolant pump wiring harness
- 3 Coolant pump wiring harness connector
- 4 Cable tie



Routing wiring harnesses in passenger compartment

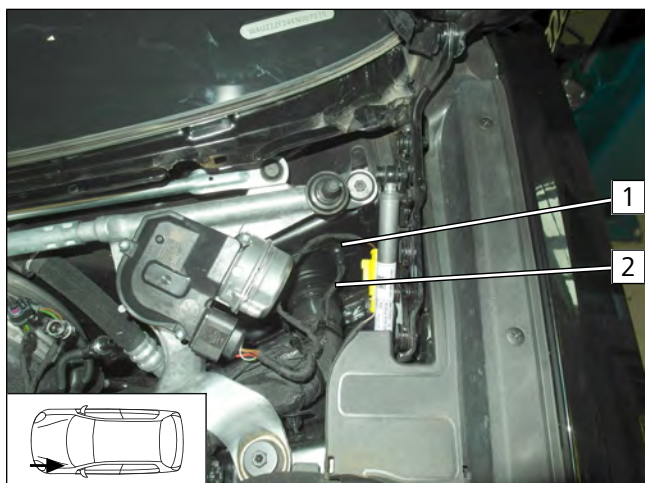

Fig. 9



WARNING

Risk of water penetration

- ▶ Route the wiring harnesses upwards to the pass through and outside the direct dripping area of the water drain chamber cover (water drain).
- ▶ Seal the pass through by using an appropriate sealing compound.

- 1 Protective rubber plug
- 2 Passenger compartment and control element wiring harnesses

Detaching connector

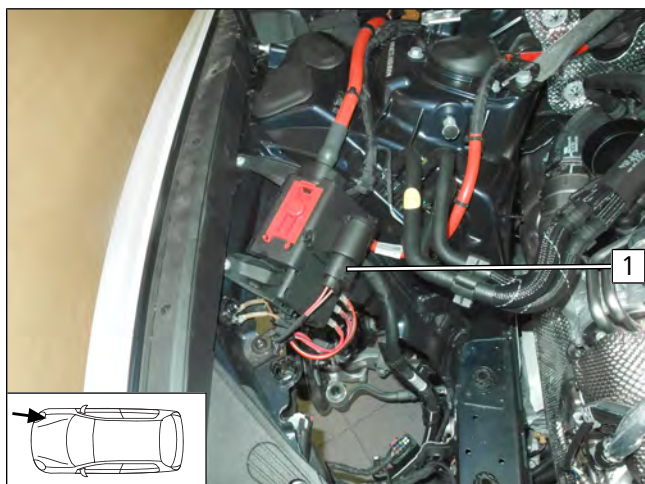

Fig. 10

- 1 Connectors

Connecting positive wire

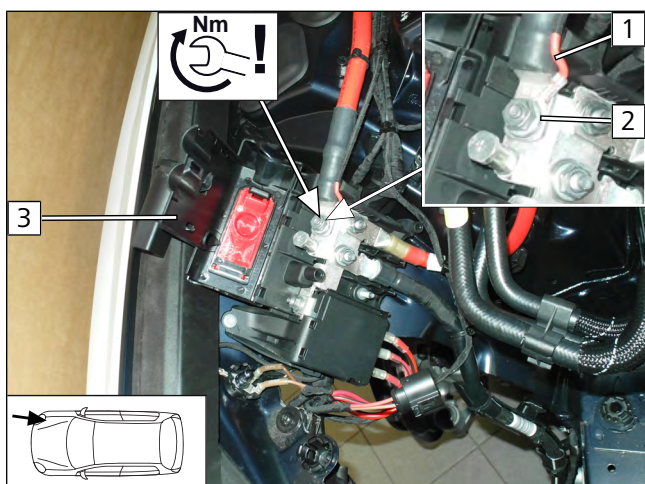

Fig. 11



DANGER

Observe tightening torque

- ▶ Open cover **3**.
- 1 Positive wire
 - 2 Original vehicle positive support point



Connecting earth wire

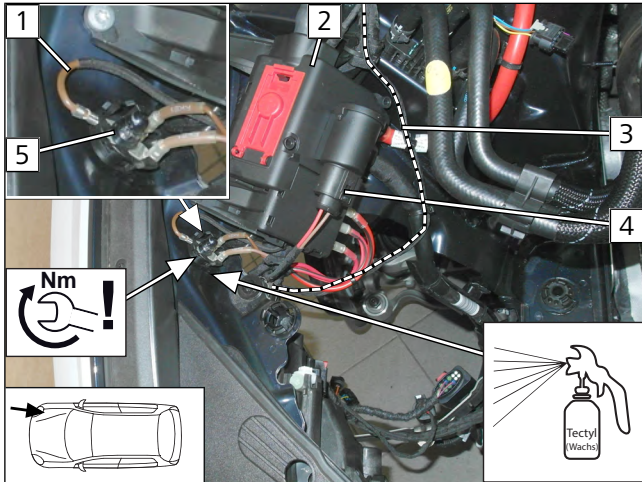

Fig. 12

- ▶ Close cover **2**.
- ▶ Connect connector **4**.



DANGER

Observe tightening torque

- 1** Earth wire
- 3** Heater wiring harness
- 5** Original vehicle earth support point

Routing wiring harnesses to heater installation location

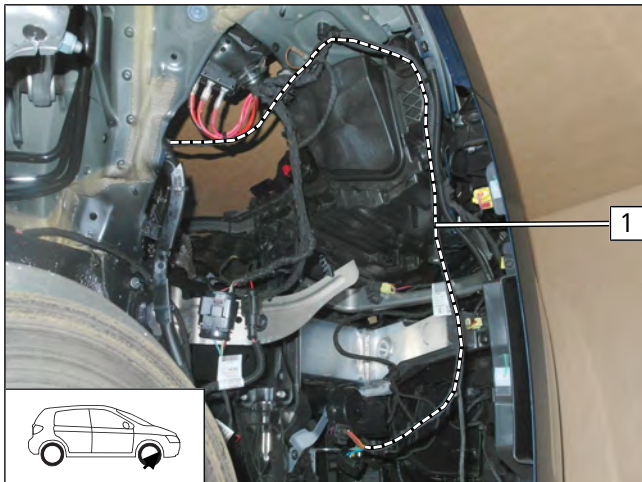

Fig. 13

- ▶ Route heater and coolant pump wiring harnesses **1** to heater installation location.



8 Mechanical system

8.1 Preparing installation location

Removing original vehicle bracket

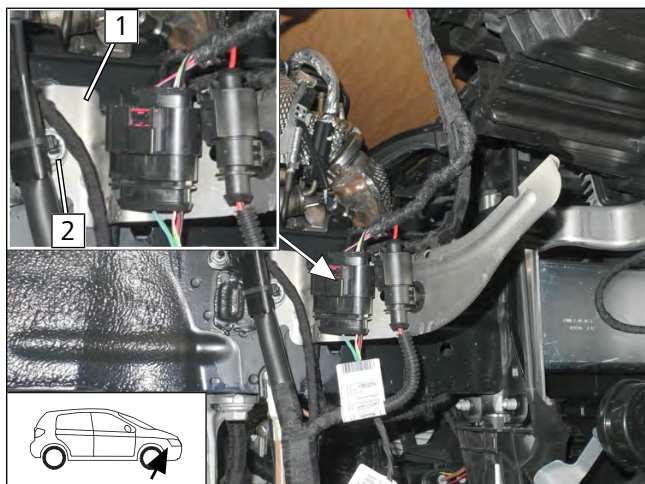

Fig. 14

- Unscrew original vehicle bolt **2**, put bracket with connector **1** aside.

Inserting rivet nut

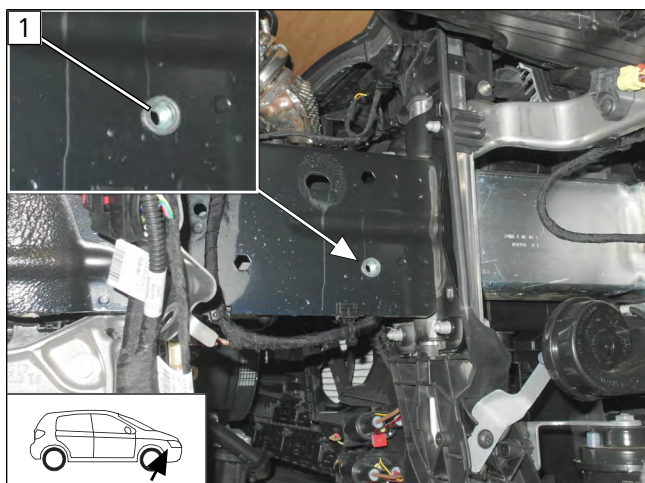

Fig. 15

- 1** M8 rivet nut in original vehicle hole

Preparing heater bracket

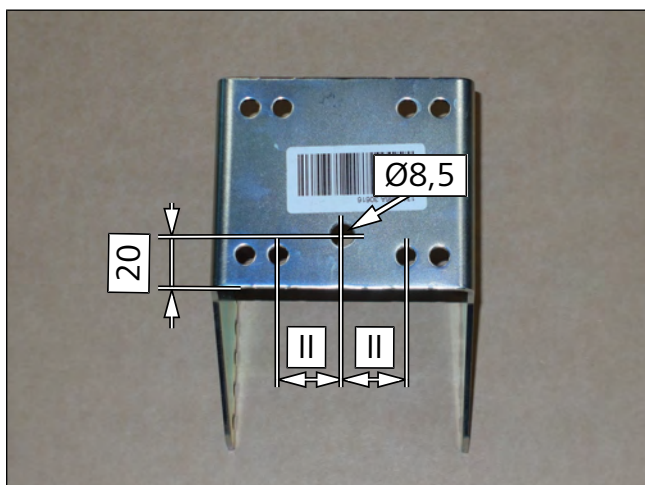

Fig. 16



Copy hole pattern

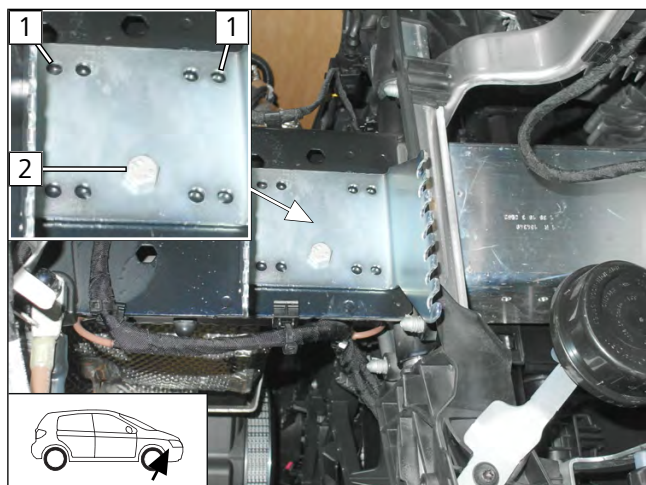

Fig. 17

► Mount heater bracket.

- 1 Hole pattern
- 2 M8x20 bolt

Drilling holes, inserting rivet nuts

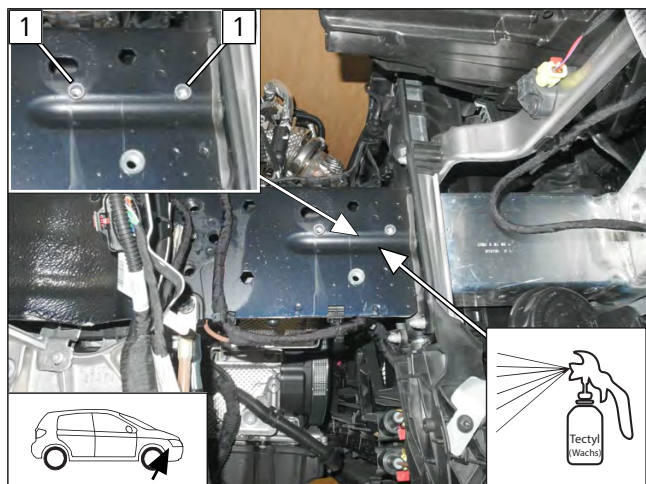

Fig. 18

► Remove heater bracket again.

- 1 Ø9 hole; M6 rivet nut

Drilling hole, inserting rivet nut

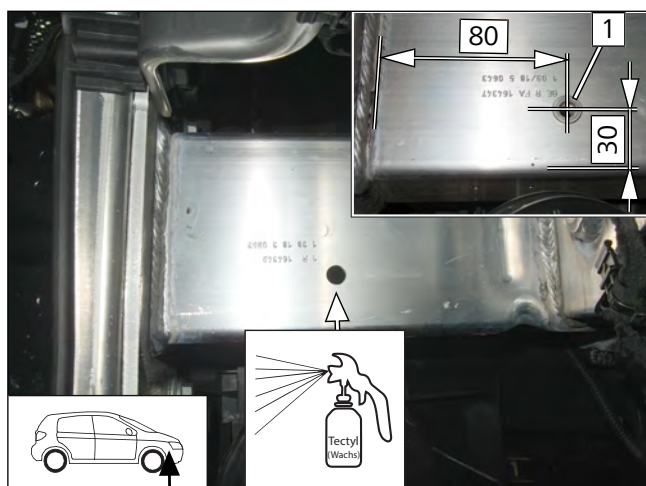

Fig. 19

- 1 M6 rivet nut



Preparing combustion air intake silencer bracket

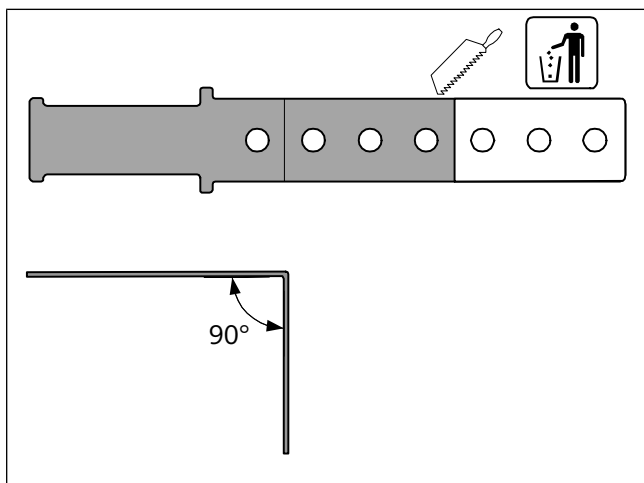

Fig. 20

Mounting combustion air intake silencer bracket

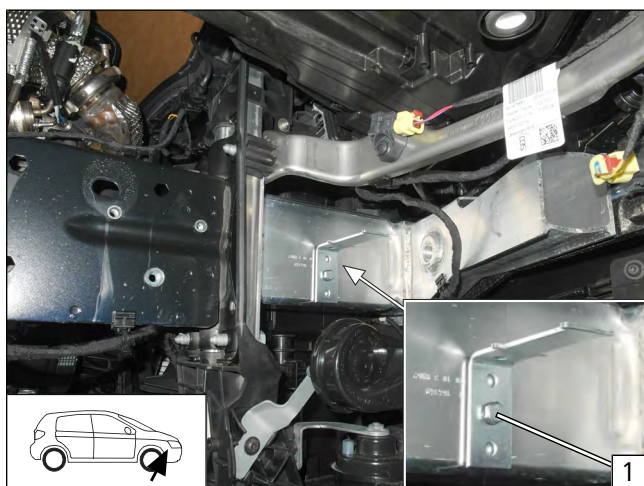

Fig. 21

- 1 M6x20 bolt, spring lock washer, bracket, rivet nut

Mounting heater bracket

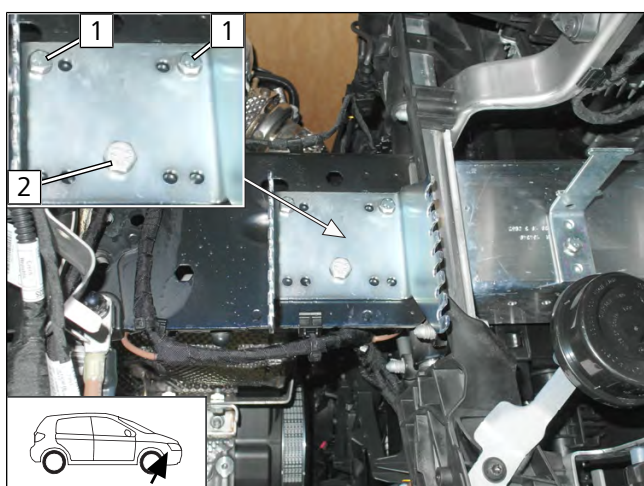

Fig. 22

- 1 M6x20 bolt, spring lock washer, bracket, rivet nut
- 2 M8x20 bolt, spring lock washer, bracket, rivet nut



8.2 Premounting heater



Observe the general installation instructions of the heater.

Mounting water connection piece with sealing ring and retaining plate

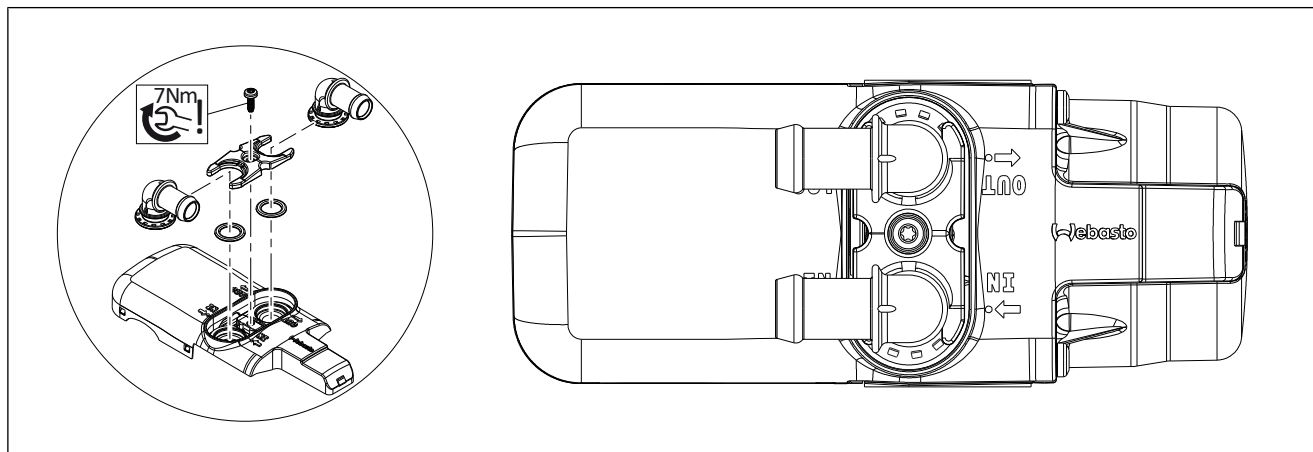

Fig. 23

Preparing hoses

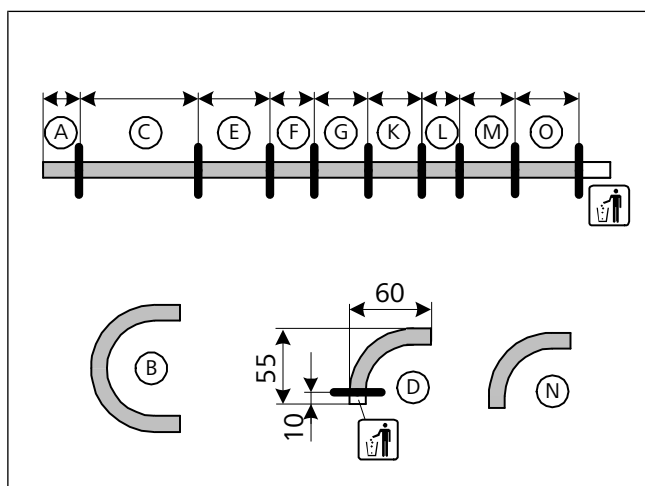

Fig. 24

A	100
B	180° moulded hose
C	420
D / N	90° moulded hose
E	300
F	130
G	240
K	210
L	135
M	270
O	300

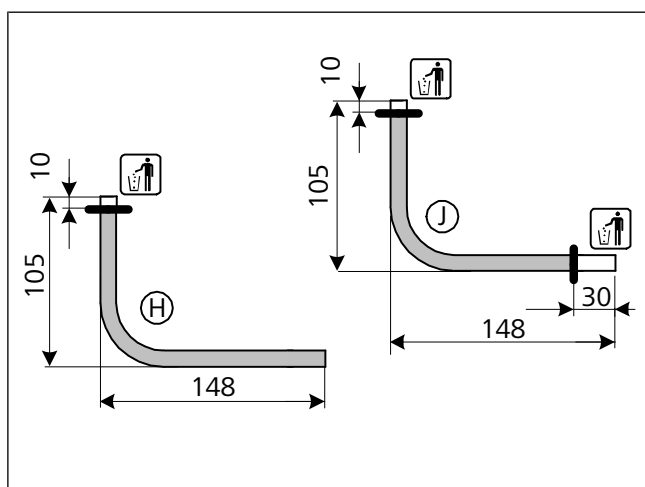
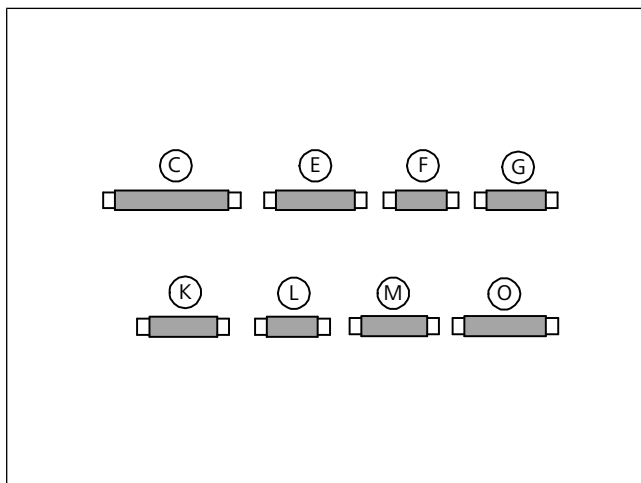

Fig. 25

H / J	90° moulded hose
--------------	------------------



► Slide on fabric heat shrink tubings, cut to length and shrink.

Fig. 26

Mounting hoses

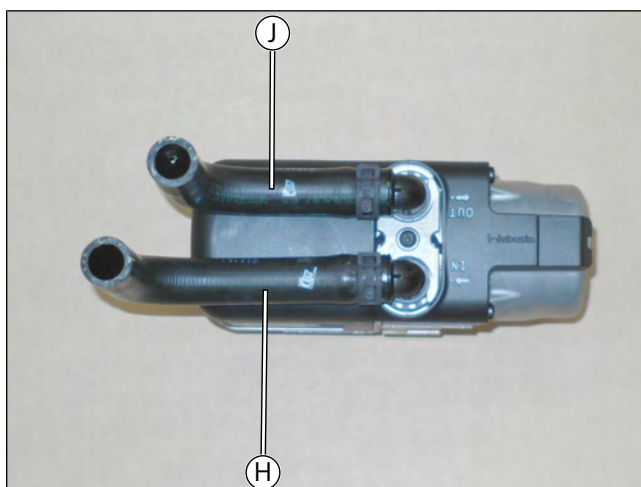

All spring clips Ø25

Fig. 27

Premounting M5x13 self-tapping bolts

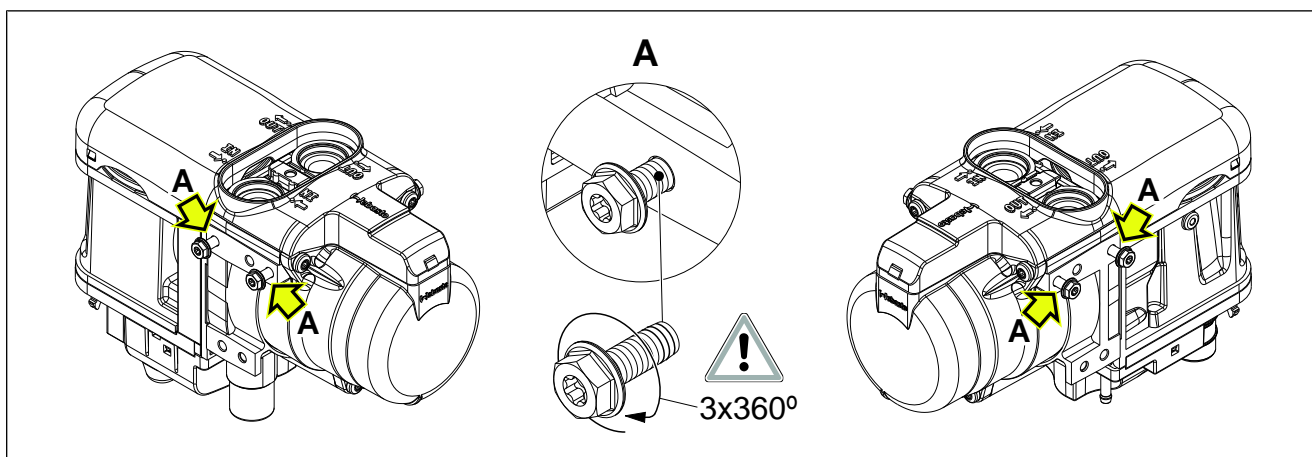

Fig. 28



Preparing angle bracket

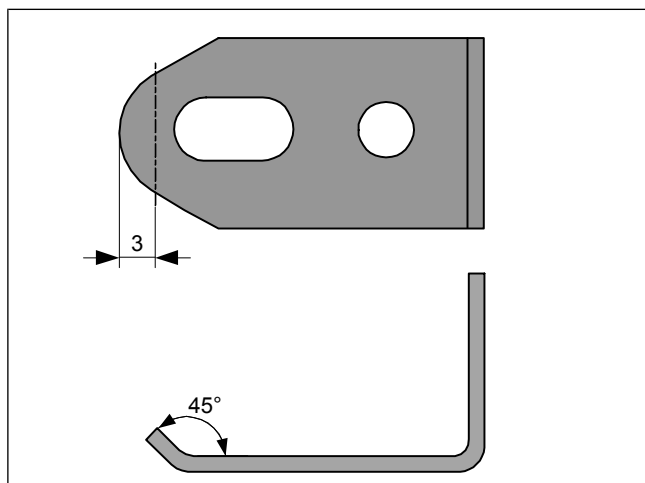

Fig. 29

Mounting angle bracket

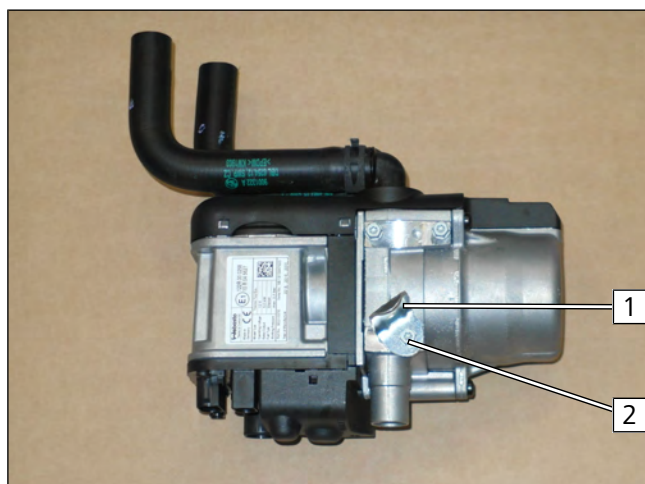

Fig. 30

- 1 Angle bracket
- 2 5x13 self-tapping bolt, mount loosely

8.3 Heater mounting

Mounting heater

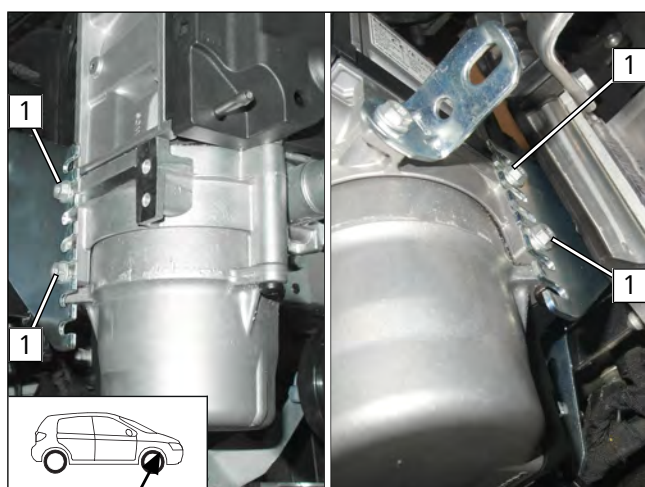



Fig. 31

 Observe the general installation instructions of the heater.

- Tighten 5x13 self-tapping bolt 1.



Mounting wiring harnesses

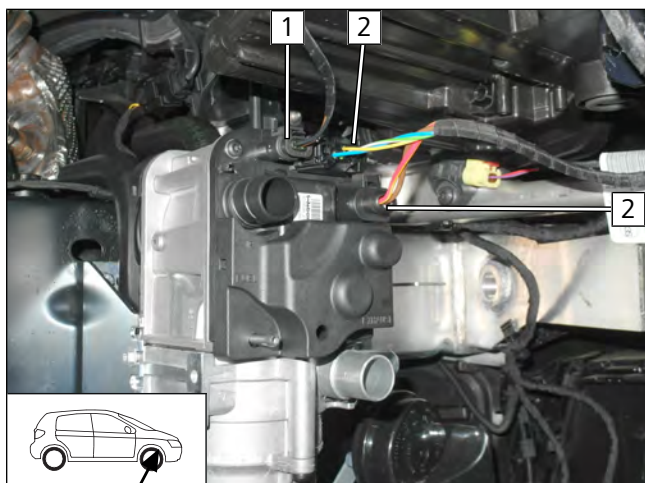

- 1** Coolant pump wiring harness connector
- 2** Heater wiring harness connector

Fig. 32



9 Combustion air

Premounting combustion air intake silencer

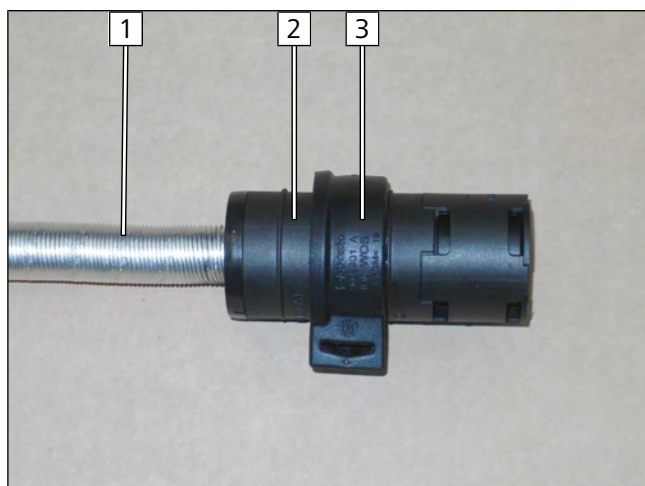

Fig. 33



Observe the installation instructions of the combustion air intake silencer.

- 1 Combustion air pipe
- 2 Combustion air intake silencer
- 3 Slide mount onto combustion air intake silencer as shown

Mounting combustion air intake silencer

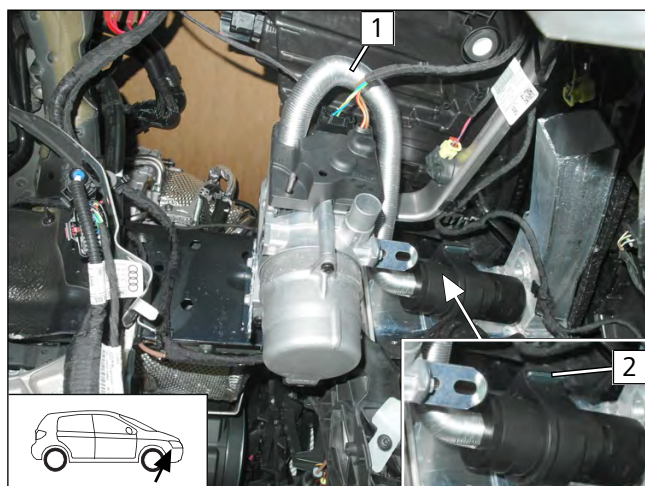

Fig. 34



Observe the installation instructions of the combustion air intake silencer.

- 1 Combustion air pipe
- 2 Slide mount onto bracket



10 Exhaust

10.1 Mounting exhaust silencer

Cutting exhaust pipe to length

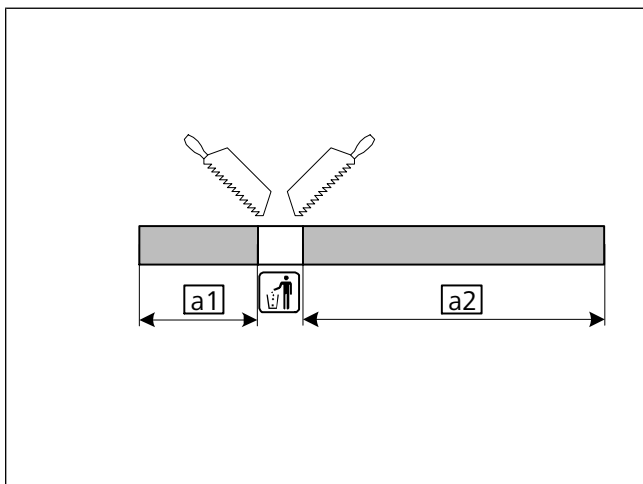

a1 190

a2 400

Fig. 35

Mounting exhaust silencer and exhaust pipe **a1**

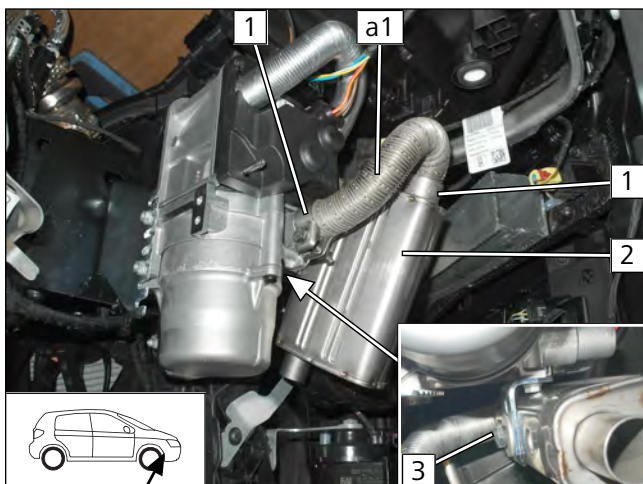

- 1** Hose clamp
- 2** Exhaust silencer
- 3** M6x16 bolt, spring lock washer, large diameter washer, angle bracket, exhaust silencer

Fig. 36

Mounting exhaust pipe **a2**

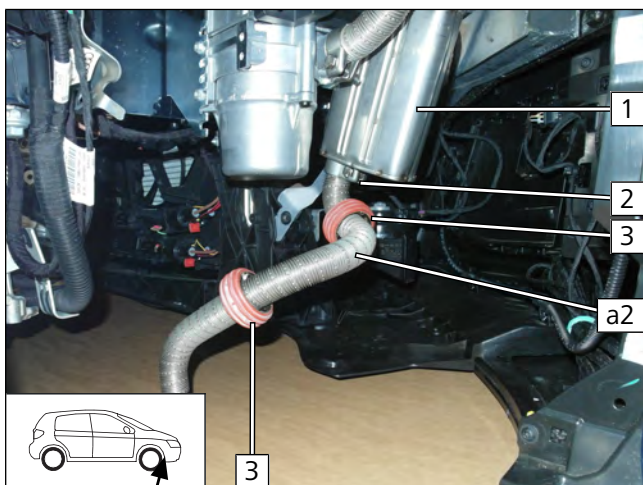

- 1** Exhaust silencer
- 2** Hose clamp
- 3** Spacer bracket

Fig. 37



Checking distance

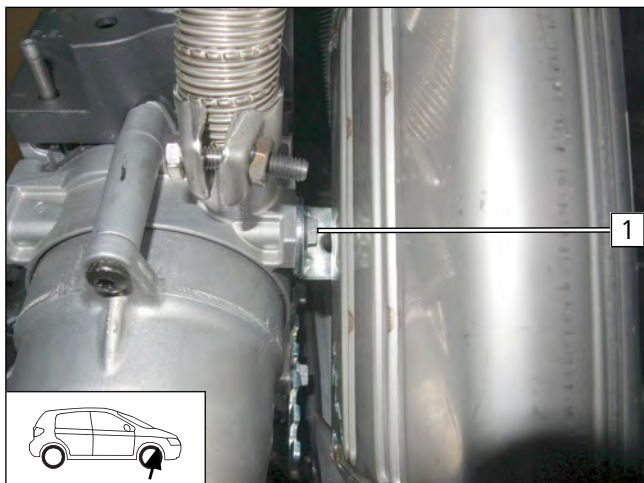

Fig. 38



Ensure sufficient space around the exhaust silencer, correct if necessary.



► Tighten bolt **1**.

10.2 Mounting exhaust end fastener

Work steps E1/E2

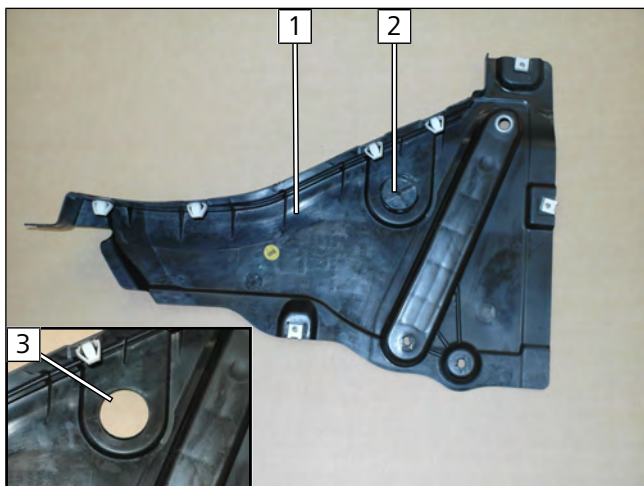

Fig. 39



Observe the EFIX installation instructions.

- 1** Underride protection
- 2** Remove plug
- 3** Hole

Work step E3

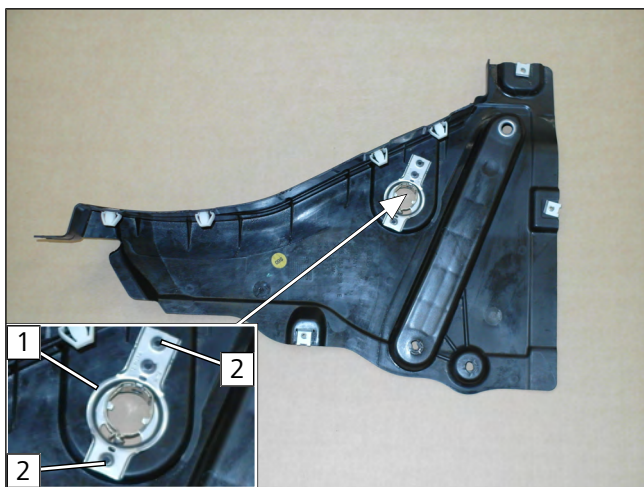

Fig. 40

- 1** EFIX
- 2** Hole pattern



Work step E4

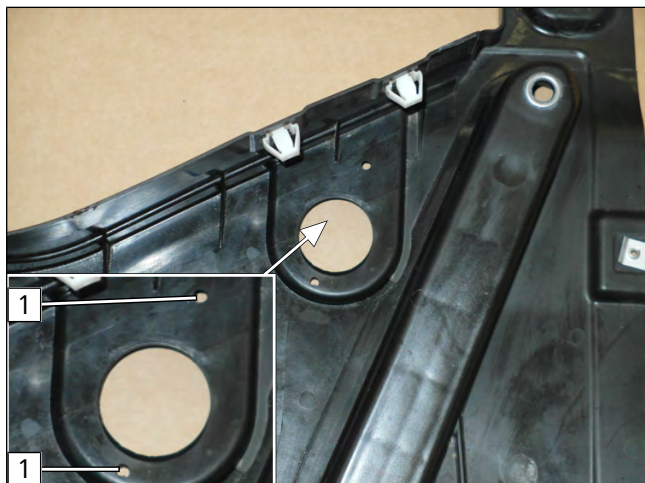

Fig. 41

- 1 Hole

Work step E5



Fig. 42

- 1 5x13 self-tapping screw
- 2 EFIX

Work step E6-8

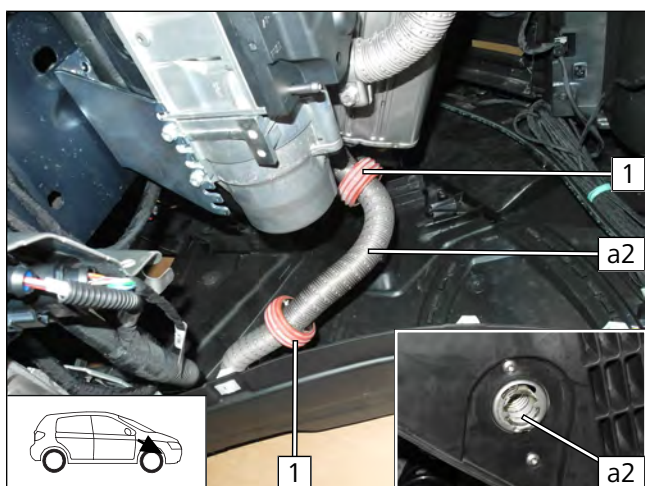

Fig. 43

- Mount underide protection.
- Align exhaust pipe **a2** as well as spacer bracket **1**.



11 Fuel



DANGER

Risk of fire and explosion due to leaking fuel and escaping fuel vapours.

The incorrect installation of the fuel extractor can cause damage and fire.

- ▶ Avoid electrostatic discharges and open fire
- ▶ When working on the fuel system, ensure sufficient ventilation and bleeding
- ▶ Open the fuel tank cap of the vehicle
- ▶ Ventilate the fuel tank
- ▶ Re-close the tank lock
- ▶ Catch any fuel running off with an appropriate container



Danger of damage to components

- ▶ Install fuel line and fuel pump wiring harness so that they are protected against stone impact
- ▶ Provide rub protection for fuel line and wiring harness in areas where there are sharp edges

Dismantling fuel pump connector X7

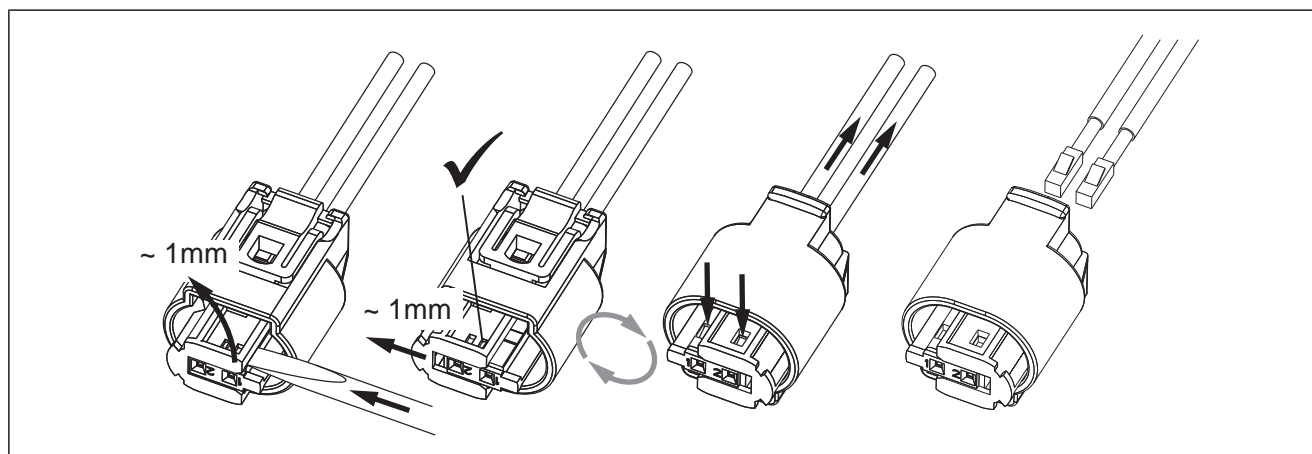
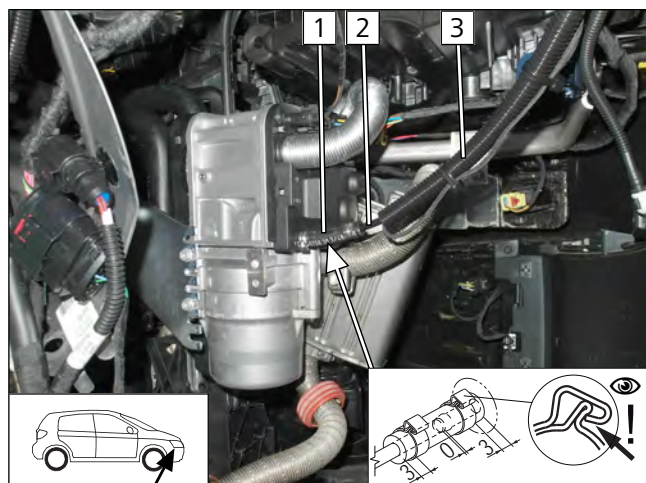

Fig. 44

11.1 Routing fuel line

Connection to heater



- 1 Hose section, Ø10 clamp [2x]
- 2 Fuel line
- 3 Fuel line and fuel pump wiring harness in Ø10 corrugated tube

Fig. 45



Routing in wheel well

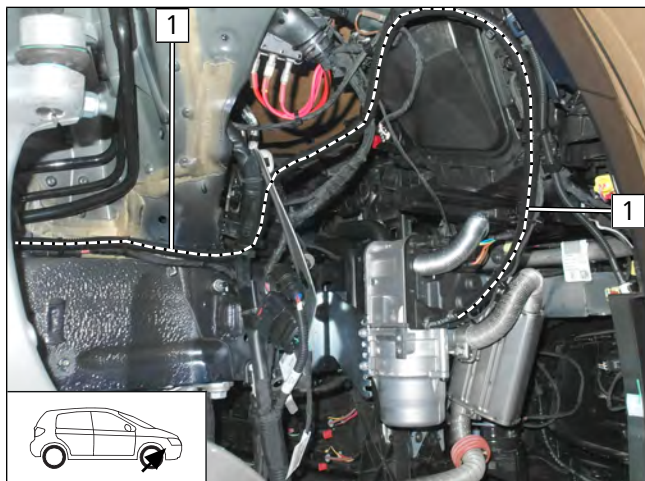

Fig. 46

- 1 Fuel line and fuel pump wiring harness in Ø10 corrugated tube

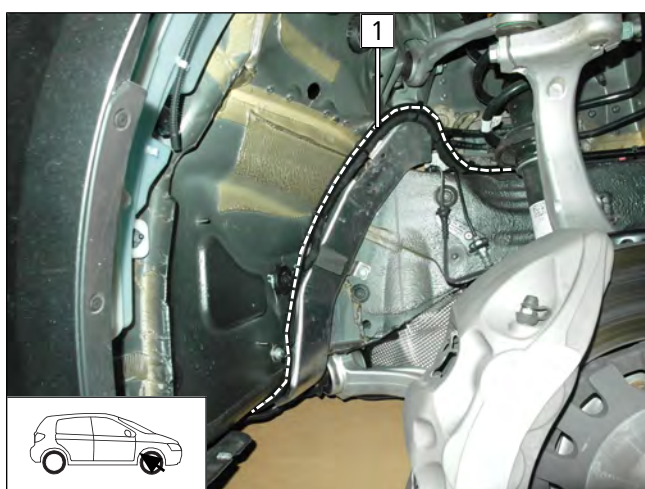

Fig. 47

- Route fuel line and fuel pump wiring harness in corrugated tube 1 to the underbody.

Routing on underbody

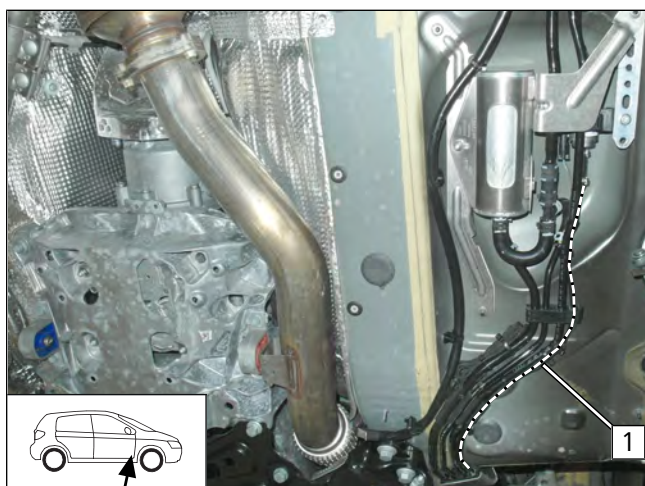

Fig. 48

- Route fuel line and fuel pump wiring harness in corrugated tube 1 along original vehicle lines on underbody to fuel pump installation location.



Premounting fuel pump

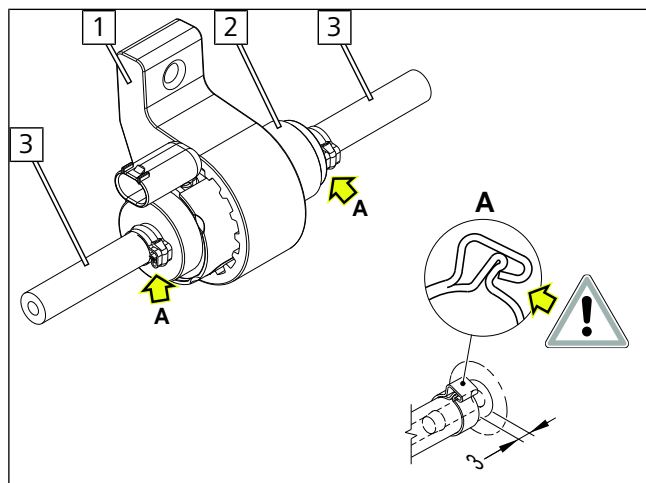

Fig. 49



The alignment of the fuel pump and fuel hoses will be carried out afterwards, during the installation.

- 1 Fuel pump mount
- 2 Fuel pump
- 3 Hose section, Ø10 clamp

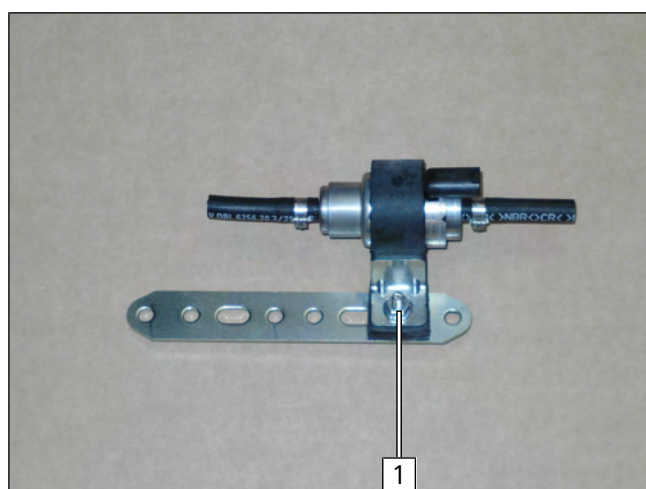

Fig. 50

- 1 M6x25 bolt, perforated bracket, fuel pump mount, support angle bracket, flanged nut

Preparing fuel pump installation location

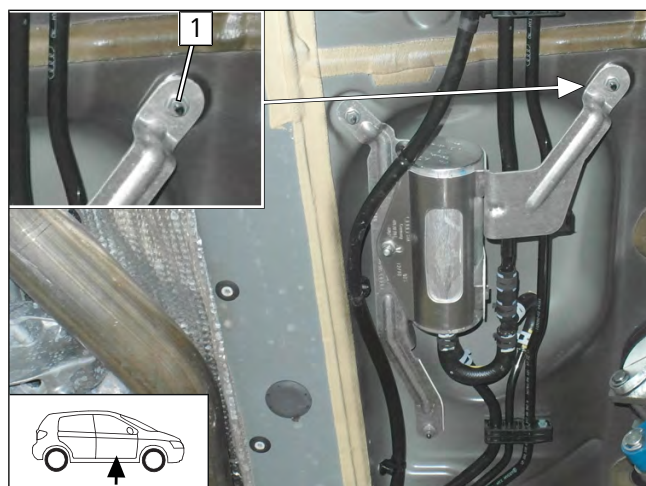

Fig. 51

- Detach original vehicle bracket 1.



Mounting fuel pump

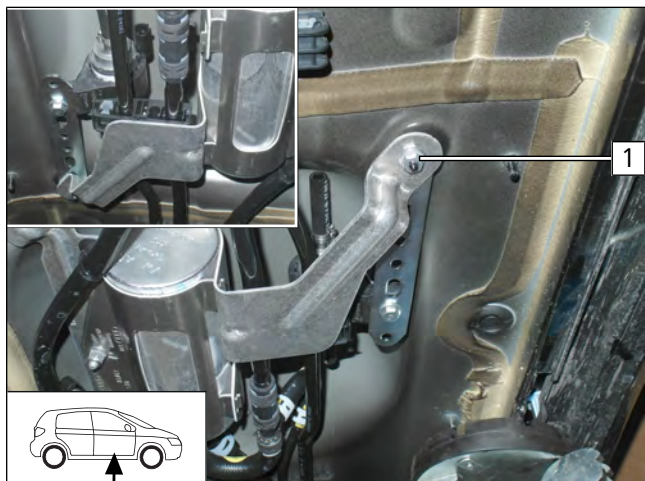

Fig. 52

- 1 Original vehicle stud bolt, perforated bracket of premounted fuel pump, original vehicle bracket, original vehicle nut

Assembling fuel pump connector X7

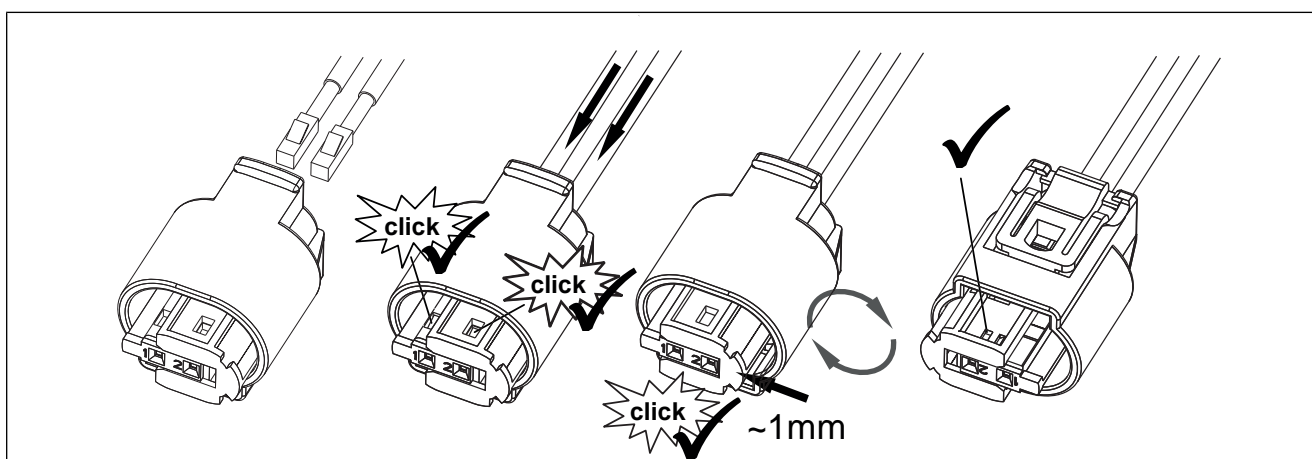

Fig. 53

Connecting fuel pump

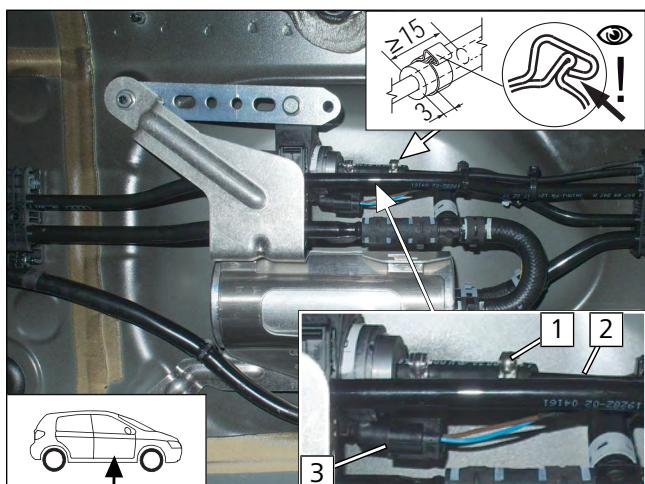
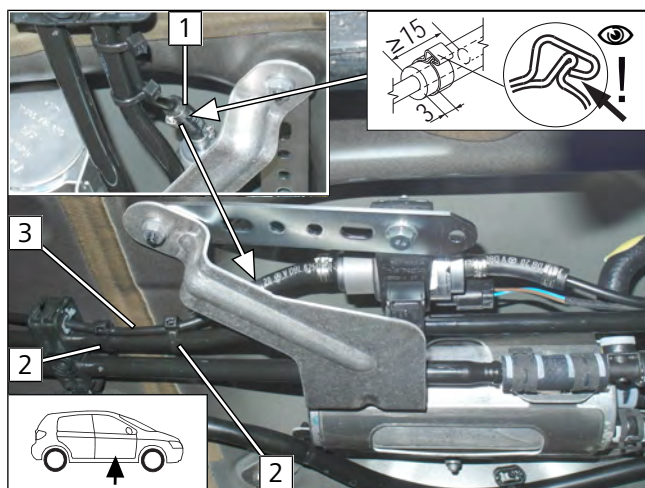

Fig. 54

- 1 Ø10 clamp
- 2 Heater fuel line
- 3 Fuel pump wiring harness, connector X7 mounted



- 1 Ø10 clamp
- 2 Cable tie
- 3 Fuel line of tank extracting device

Fig. 55

Routing line

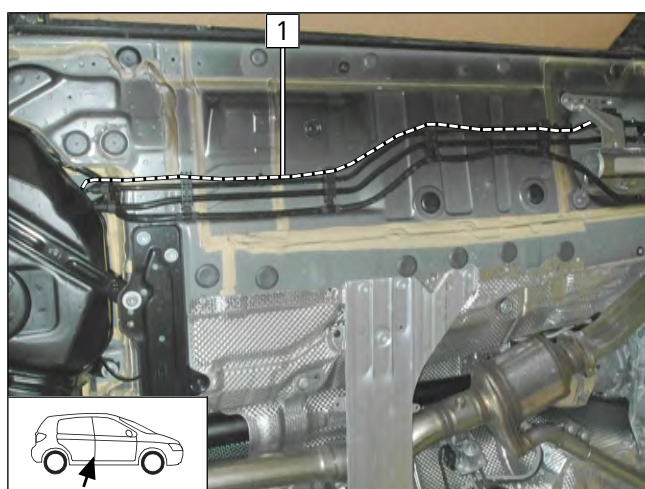

- Route fuel line 1 on underbody along original vehicle fuel line to tank fitting and secure using cable ties.

Fig. 56

11.2 Mounting tank extracting device

Preparing fuel extraction

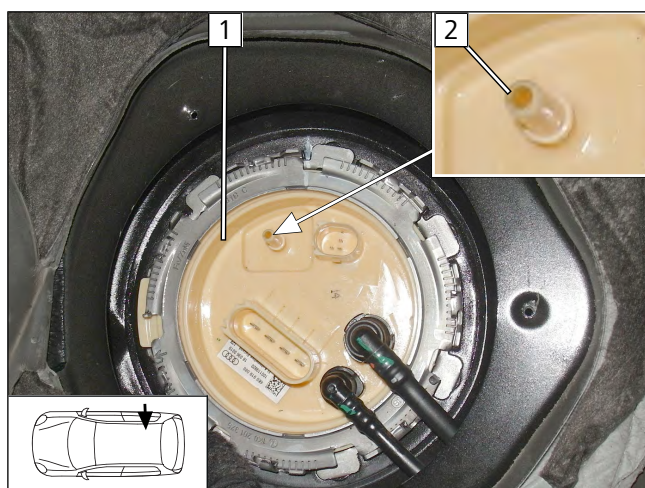

Fig. 57



DANGER

Risk of fire and explosion due to leaking fuel and escaping fuel vapours.

- Drill a Ø2.5 hole in connection piece 2 of tank fitting 1.



Cutting tank extracting device to length

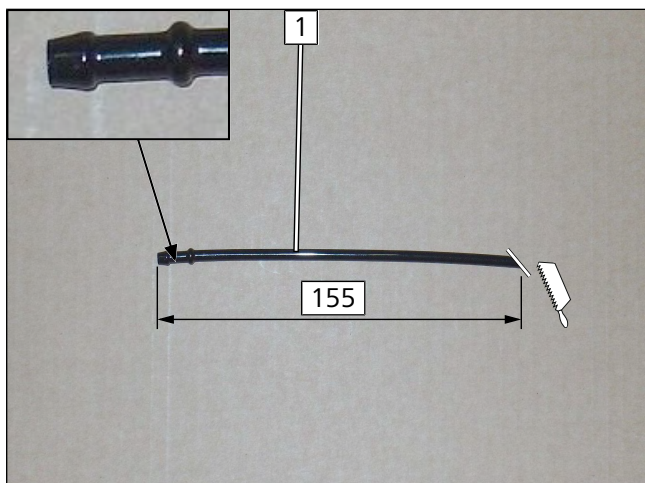

Fig. 58

► Cut standpipe **1** at an angle.

Premounting tank extracting device

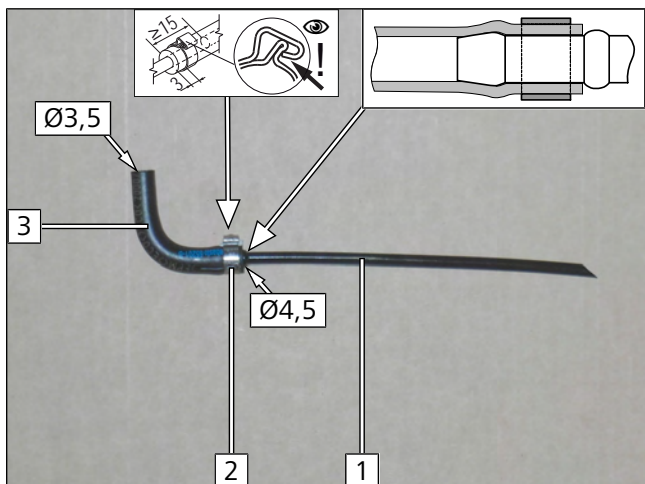

Fig. 59

- 1** Standpipe
- 2** Ø10 clamp
- 3** 90° moulded hose

Mounting tank extracting device

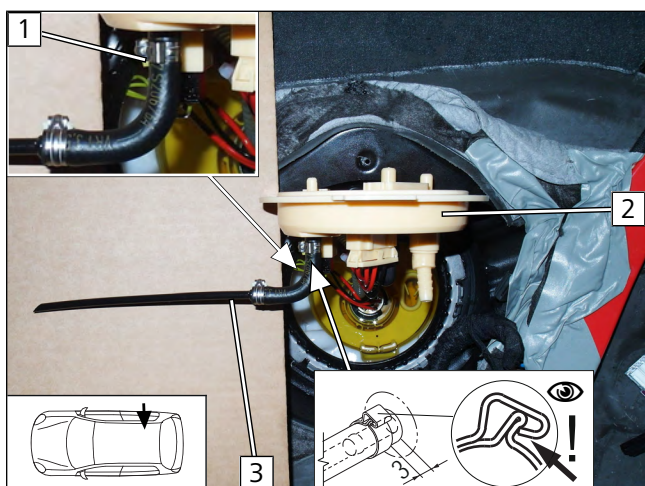

Fig. 60



Further information can be found in the vehicle manufacturer's technical documentation.

► Detach upper section of tank fitting.

- 1** Ø8 clamp
- 2** Tank fitting
- 3** Premounted tank extracting device



Installing tank extracting device

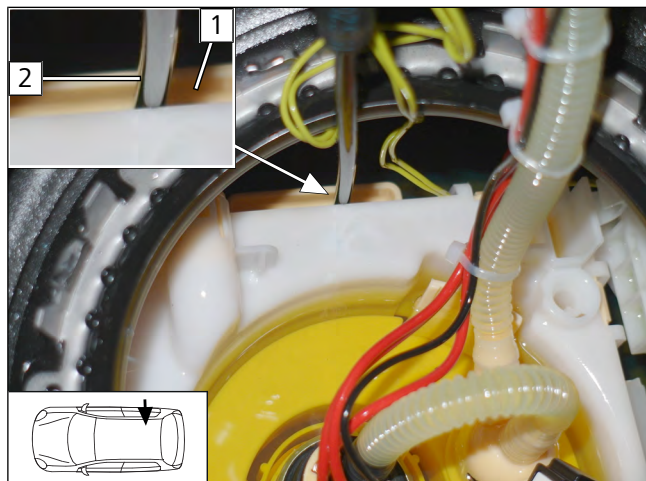

Fig. 61

- ▶ Insert tank extracting device **2** in plastic strip **1** as shown.
- ▶ Mount upper section of tank fitting.

Connecting fuel line

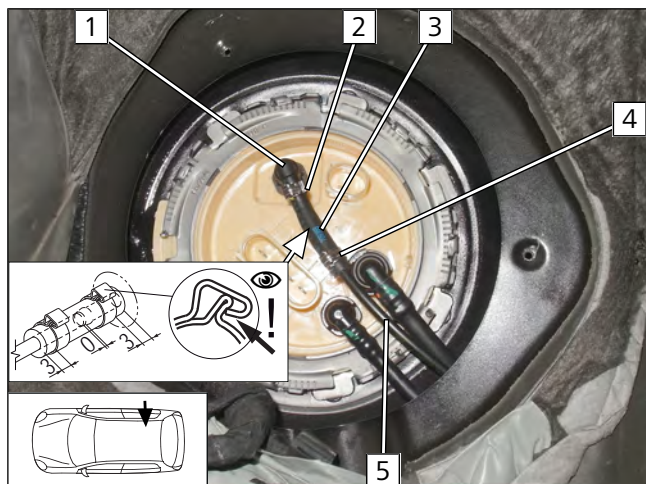

Fig. 62

- 1** Coupling
- 2** Ø8 clamp
- 3** Ø3.5xØ4.5 moulded hose
- 4** Ø10 clamp
- 5** Fuel line of tank extracting device



12 Coolant

12.1 Hose routing diagram

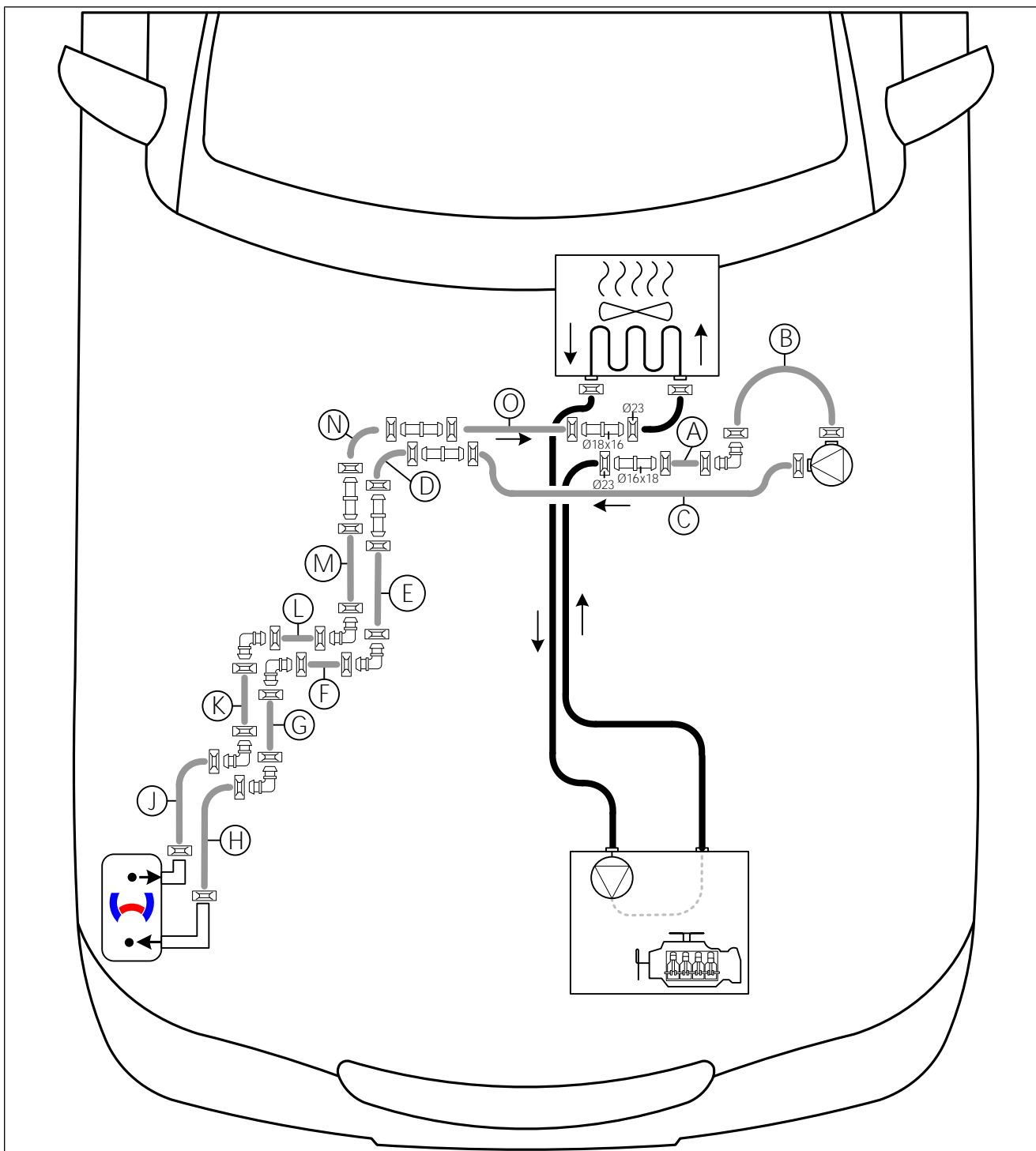

Fig. 63

All spring clips without a specific designation  = Ø25

All connecting pipes without a specific designation  = Ø18x18 or  = Ø18x18/90°



12.2 Coolant circuit preparation

Premounting cable tie

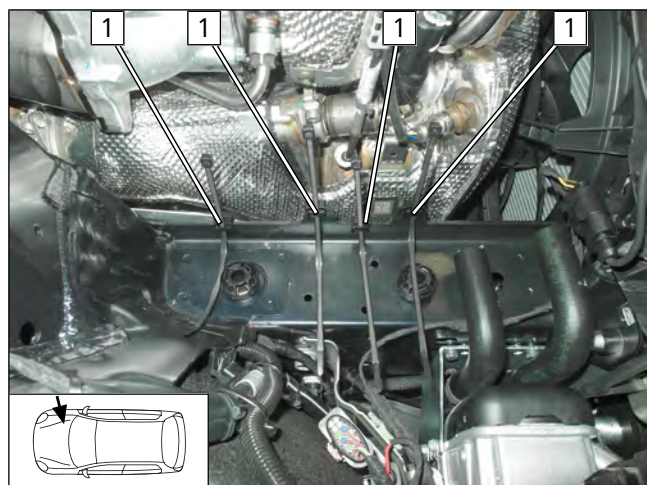

► Premount edge clip cable tie **1** on carrier.

Fig. 64

Drilling holes in water drain chamber

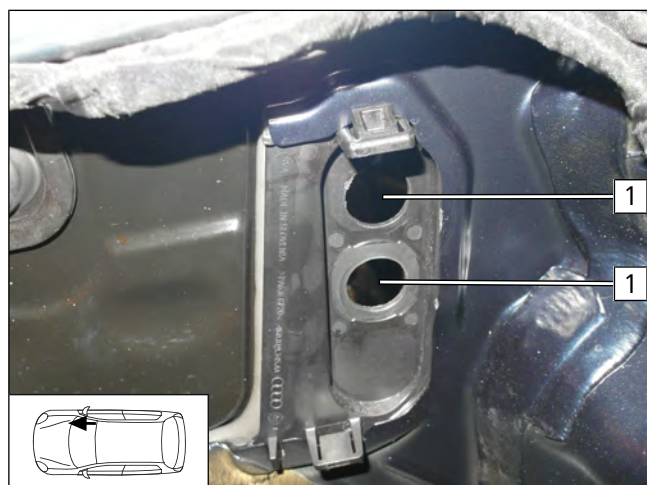

1 Ø20 hole in the centre of the water drain chamber embossing

Fig. 65

Bending coolant pump bracket

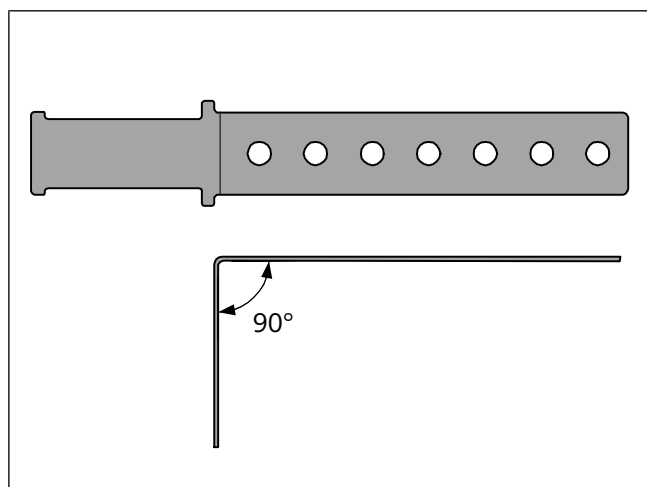

Fig. 66



Premounting coolant pump hose group

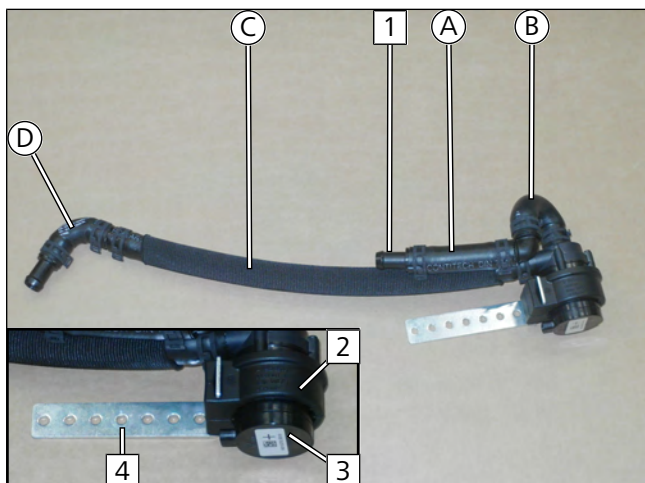

Fig. 67

► Connect long side of hose **D** to hose **C**.

- 1** Ø16x18 connecting pipe
- 2** Coolant pump mount
- 3** Coolant pump
- 4** Coolant pump bracket

Premounting heat exchanger inlet hose group

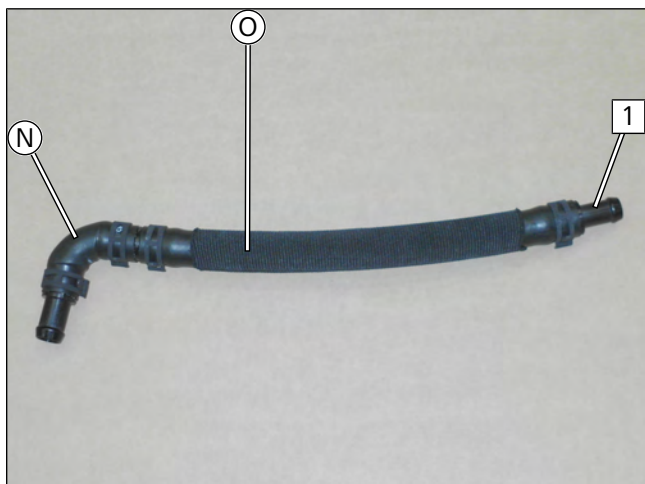

Fig. 68

- 1** Ø16x18 connecting pipe

Premounting heater inlet and heater outlet hose groups

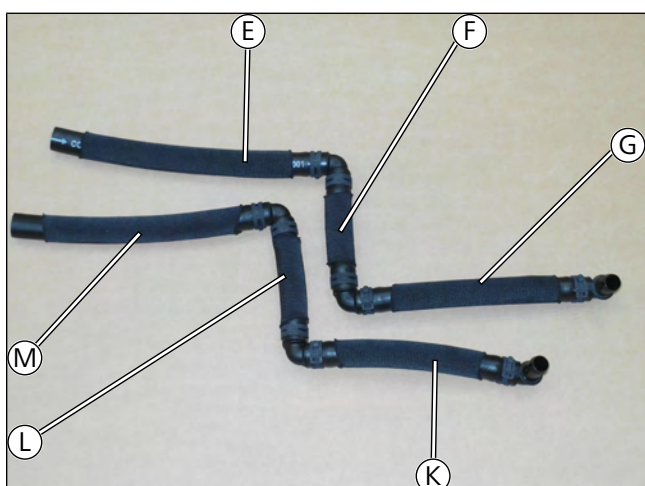

Fig. 69



12.3 Coolant circuit installation

Cutting point

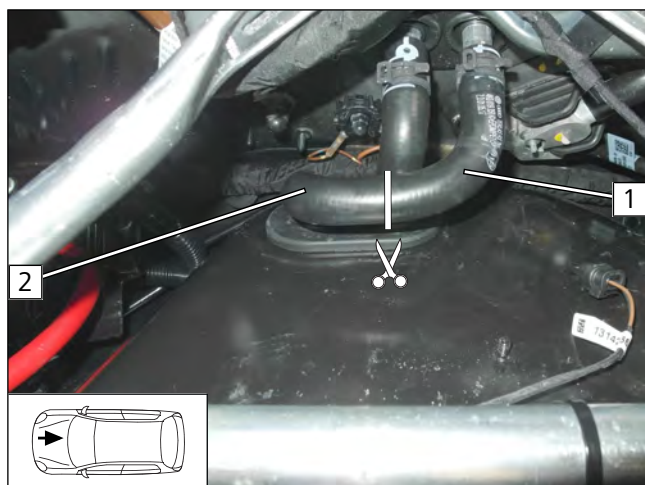

Fig. 70

- 1 Heat exchanger inlet hose section
- 2 Engine outlet hose section

Mounting heat exchanger inlet hose group

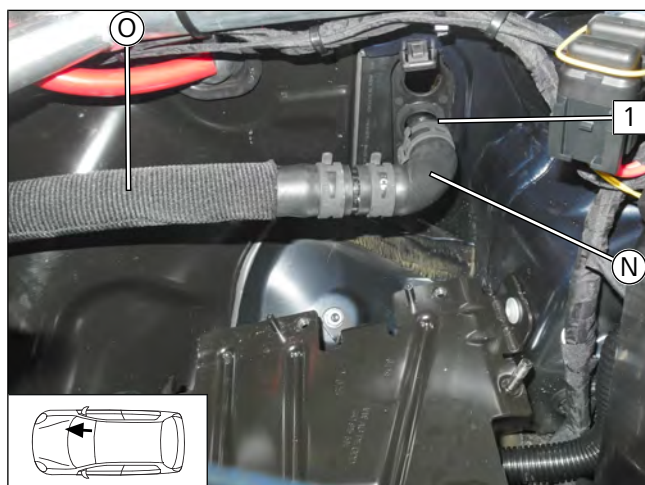

Fig. 71

- 1 Ø18x18 connecting pipe in bottom Ø20 hole of pass through in water drain chamber

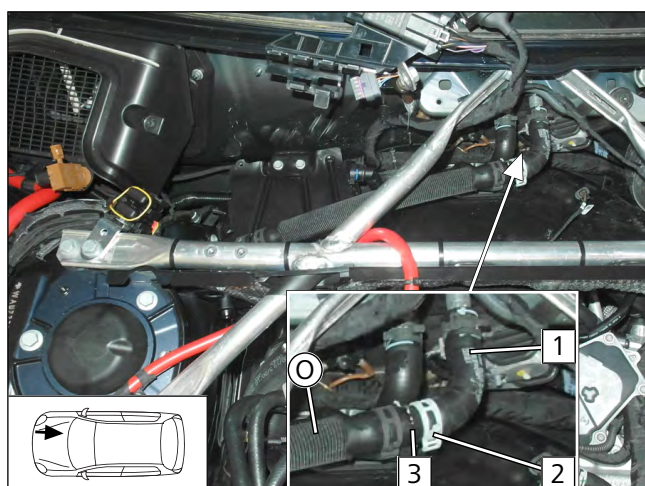

Fig. 72

- 1 Heat exchanger inlet with original vehicle spring clip
- 2 Ø23 spring clip
- 3 Ø18x16 connecting pipe



Mounting heater outlet hose group

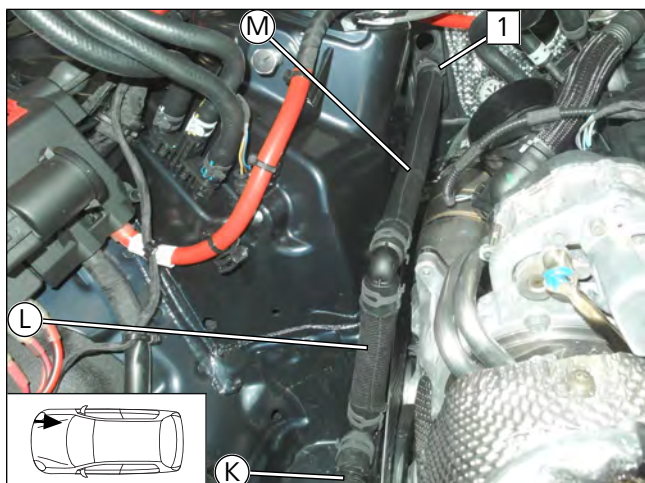

Fig. 73

- ▶ Connect hose **M** onto connecting pipe **1** of hose **N** in water drain chamber pass through.

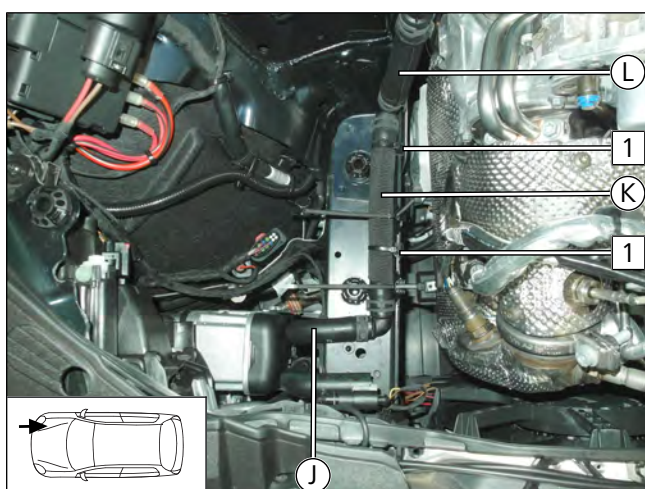

Fig. 74

- ▶ Connect hose **K** to hose **J** on heater outlet.
 - 1** Tighten premounted edge clip cable tie

Mounting coolant pump hose group

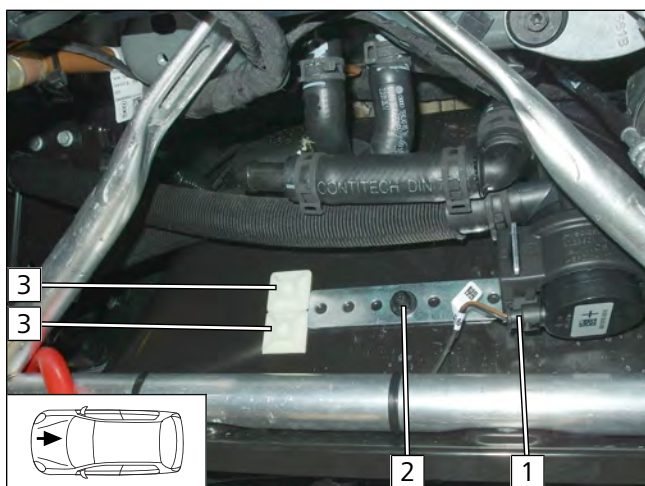

Fig. 75

- ▶ Glue adhesive base **3** centrally onto the coolant pump bracket.
 - 1** Coolant pump wiring harness connector
 - 2** Original vehicle stud bolt, coolant pump bracket, plastic nut

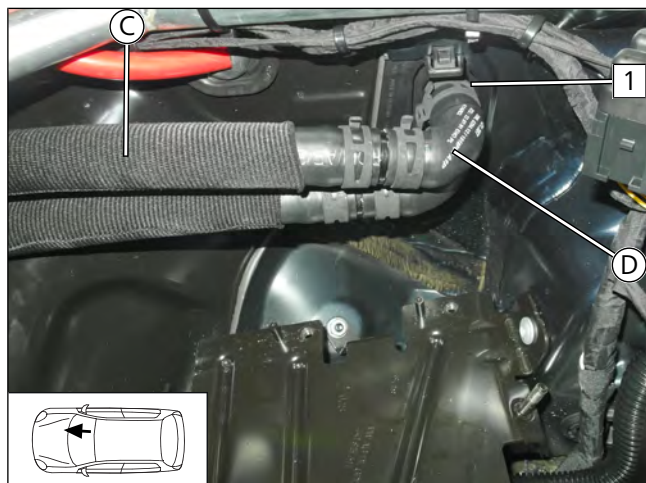

Fig. 76

- 1 Ø18x18 connecting pipe in top Ø20 hole of pass through in water drain chamber

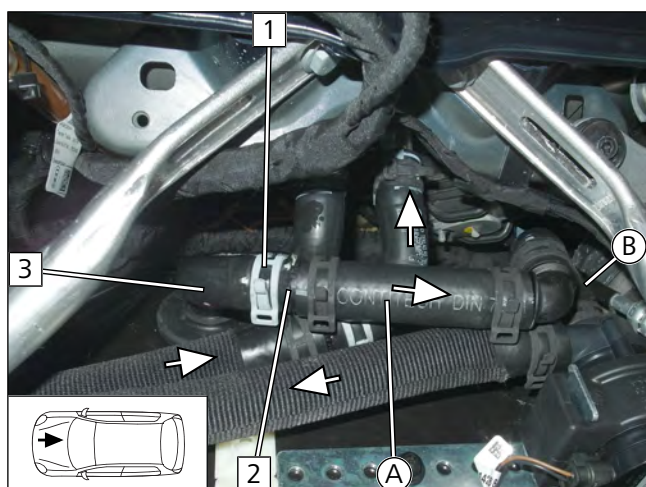

Fig. 77

- 1 Ø23 spring clip
- 2 Ø16x18 connecting pipe
- 3 Engine outlet hose section

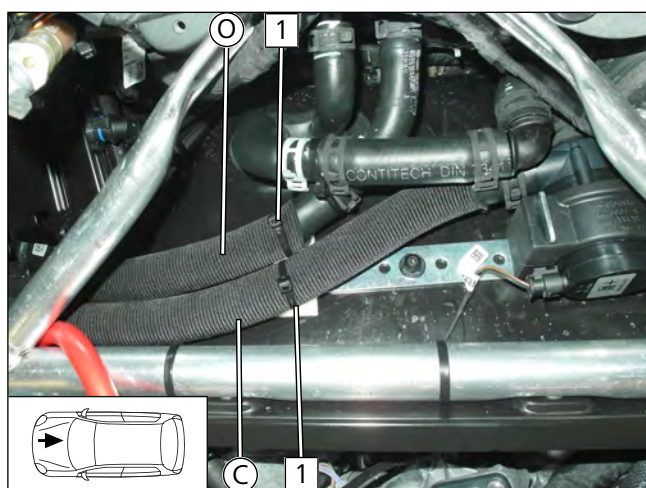

Fig. 78

- Mount cable tie 1 in adhesive base and use it to fasten hoses C and O.



Mounting heater inlet hose group

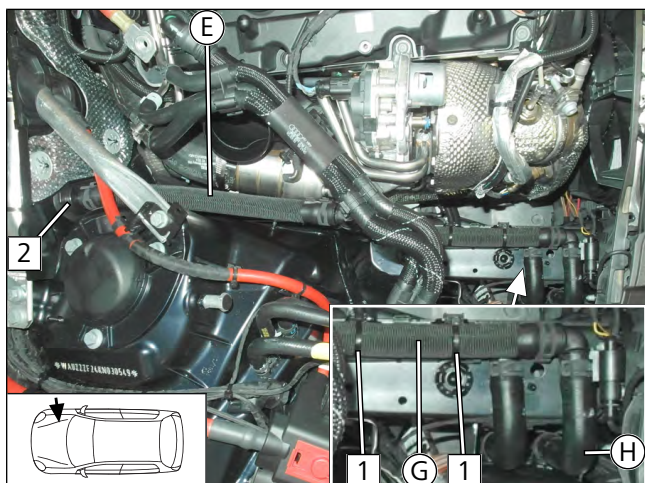

Fig. 79

► Connect hose **E** to connecting pipe **2** of hose **D** in water drain chamber pass through.

- 1 Tighten premounted edge clip cable tie

Fastening hoses

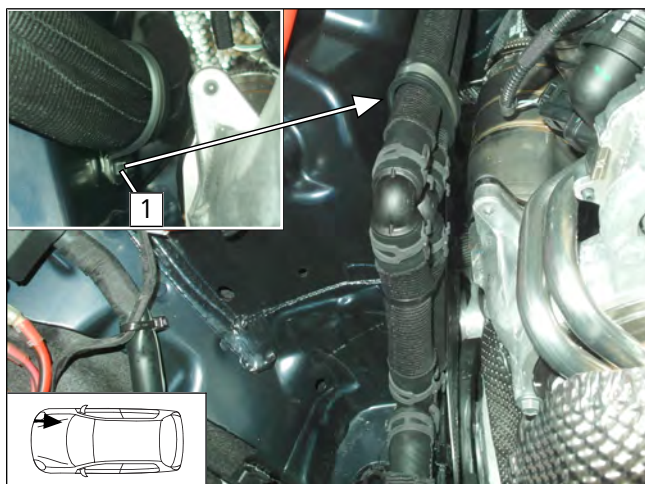

Fig. 80

- 1 Original vehicle stud bolt, rubber-coated Ø48 p-clamp, plastic nut

Checking distance

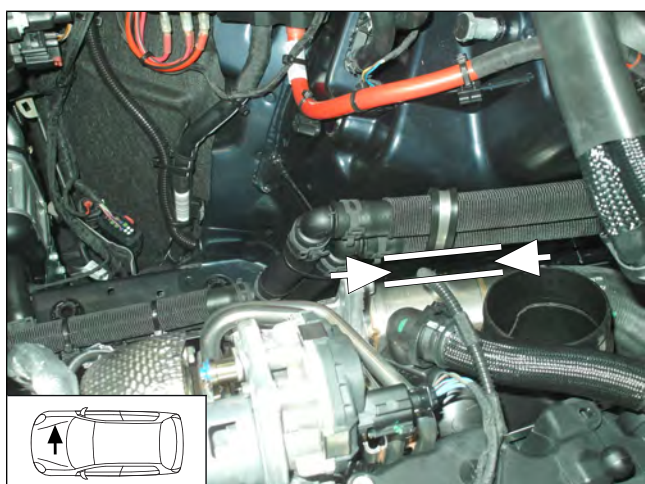

Fig. 81



Ensure sufficient distance between hoses and engine throughout the entire routing, correct if necessary.





13 Final work in engine compartment

Mounting battery in water drain chamber

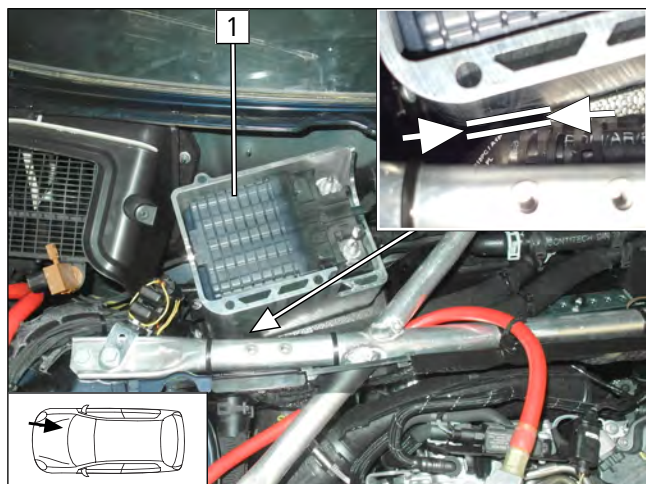
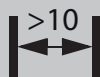

Fig. 82

- ▶ Mount battery **1**, but do not connect yet.



Ensure sufficient distance between battery bracket and hoses, correct if necessary.



Mounting original vehicle bracket

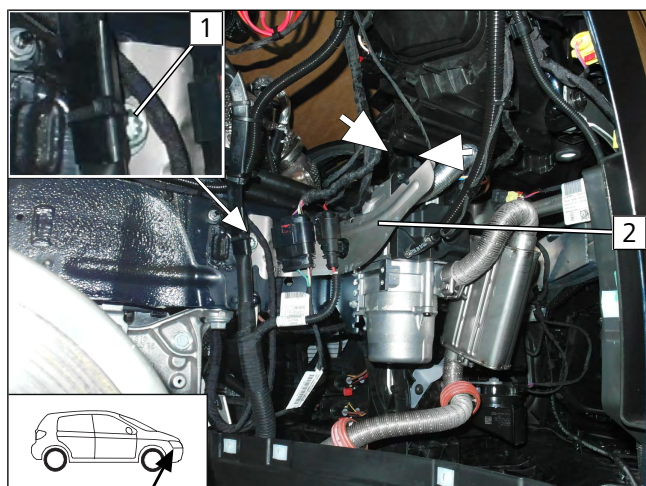

Fig. 83

- ▶ Using original vehicle bolt **1**, mount original vehicle bracket with connector **2**.



Ensure sufficient distance between headlight and heater, correct if necessary.





14 Electrical system of passenger compartment

14.1 Electrical system preparation

Assigning wires

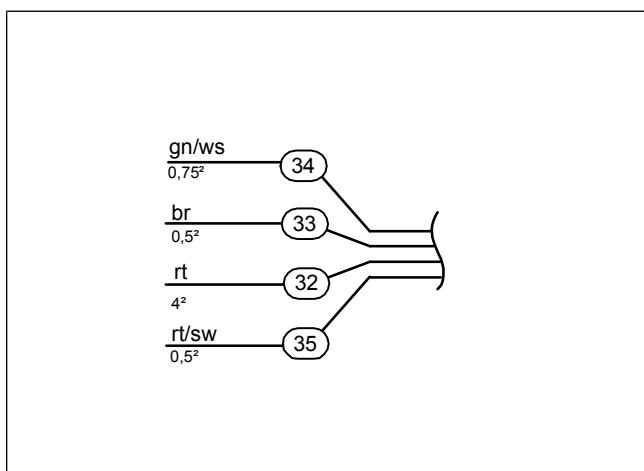

Fig. 84



Wire sections retain their numbering in the entire document.

- ③② Red (rt) wire of heater wiring harness F2
- ③③ Brown (br) wire of heater wiring harness, earth 31
- ③④ Green/white (gn/ws) wire of heater wiring harness X1/5
- ③⑤ Red/black (rt/sw) wire of heater wiring harness X10

Assigning wires

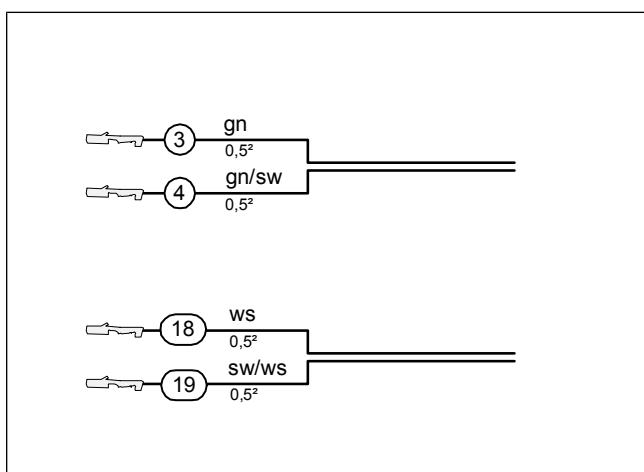

Fig. 85

- ③ Green (gn) wire from wiring harness of LIN control
- ④ Green/black (gn/sw) wire from wiring harness of LIN control
- ⑱ White (ws) wire of isolating relay wiring harness
- ⑲ Black/white (sw/ws) wire of isolating relay wiring harness

Mounting 4.8 female connector on relay K2

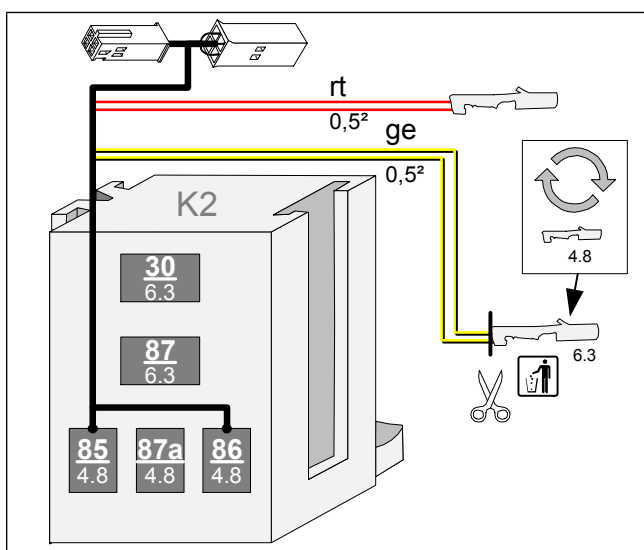

Fig. 86



Reconnect both yellow wires together to 4.8 female connector.



Preparing relay K2

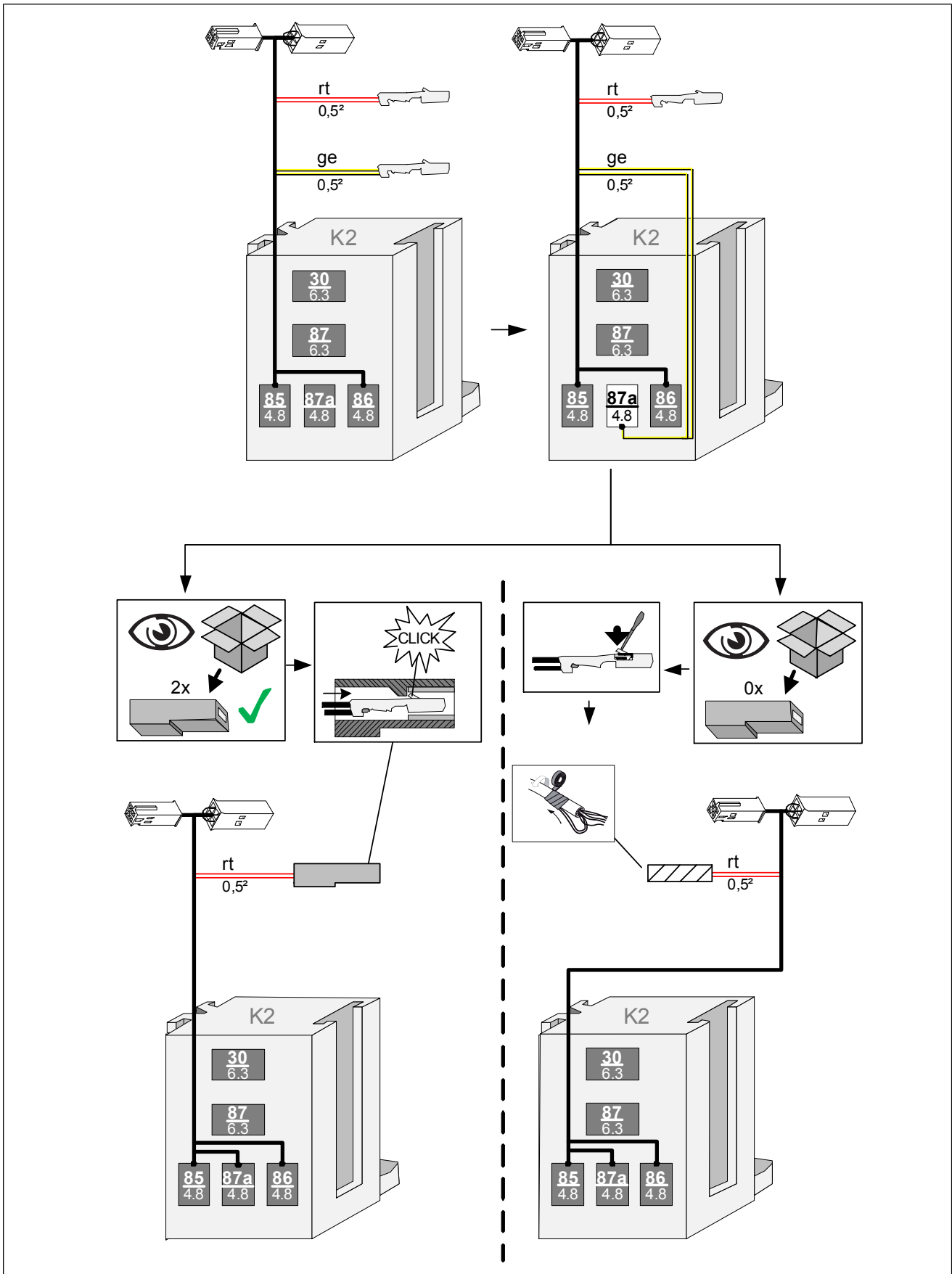

Fig. 87



Preparing relay K3

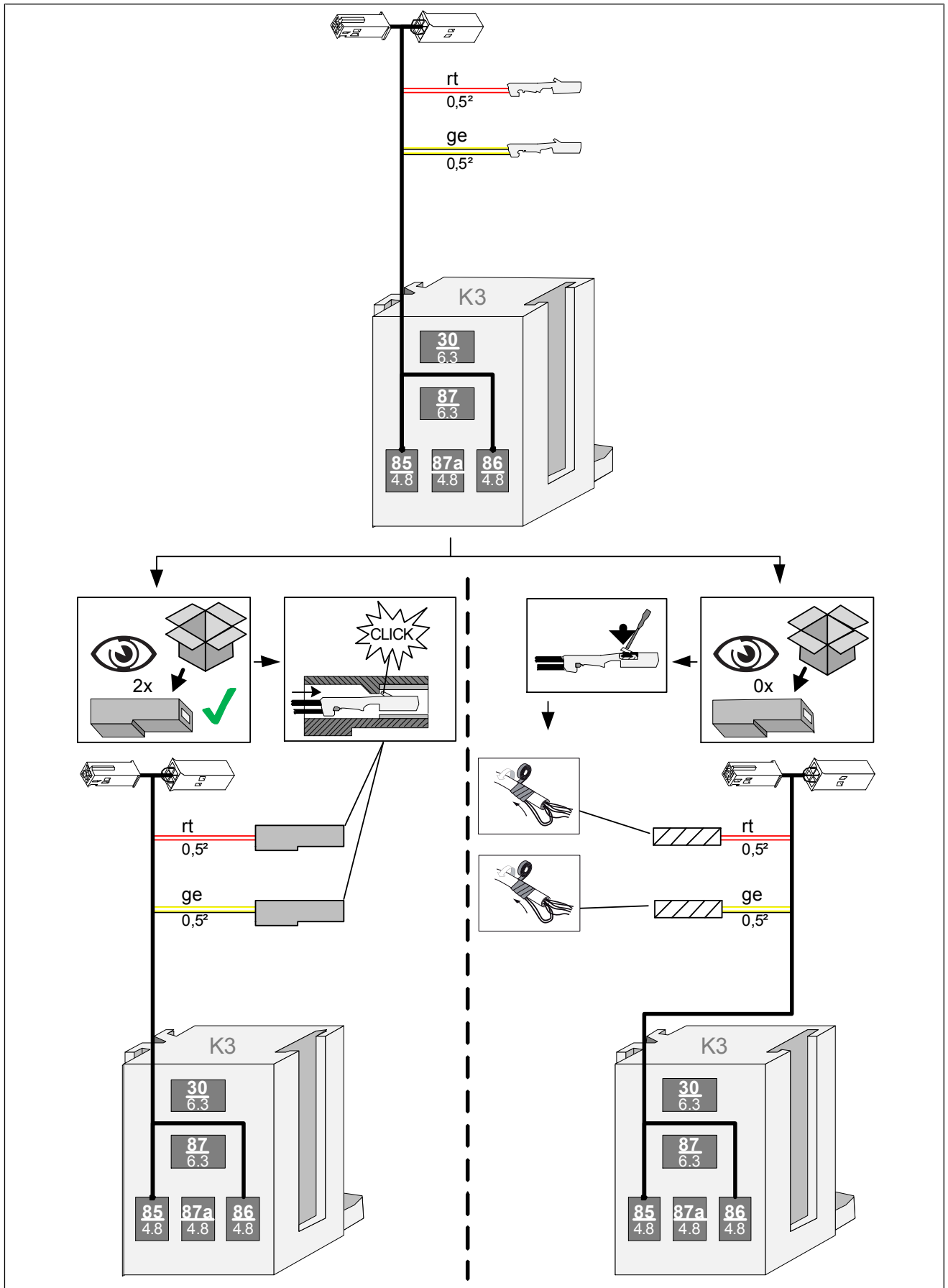

Fig. 88



Assembling / preparing CCL, K2 and K3 relay sockets

- ▶ Mounting wires
- ▶ Connect connectors and sockets

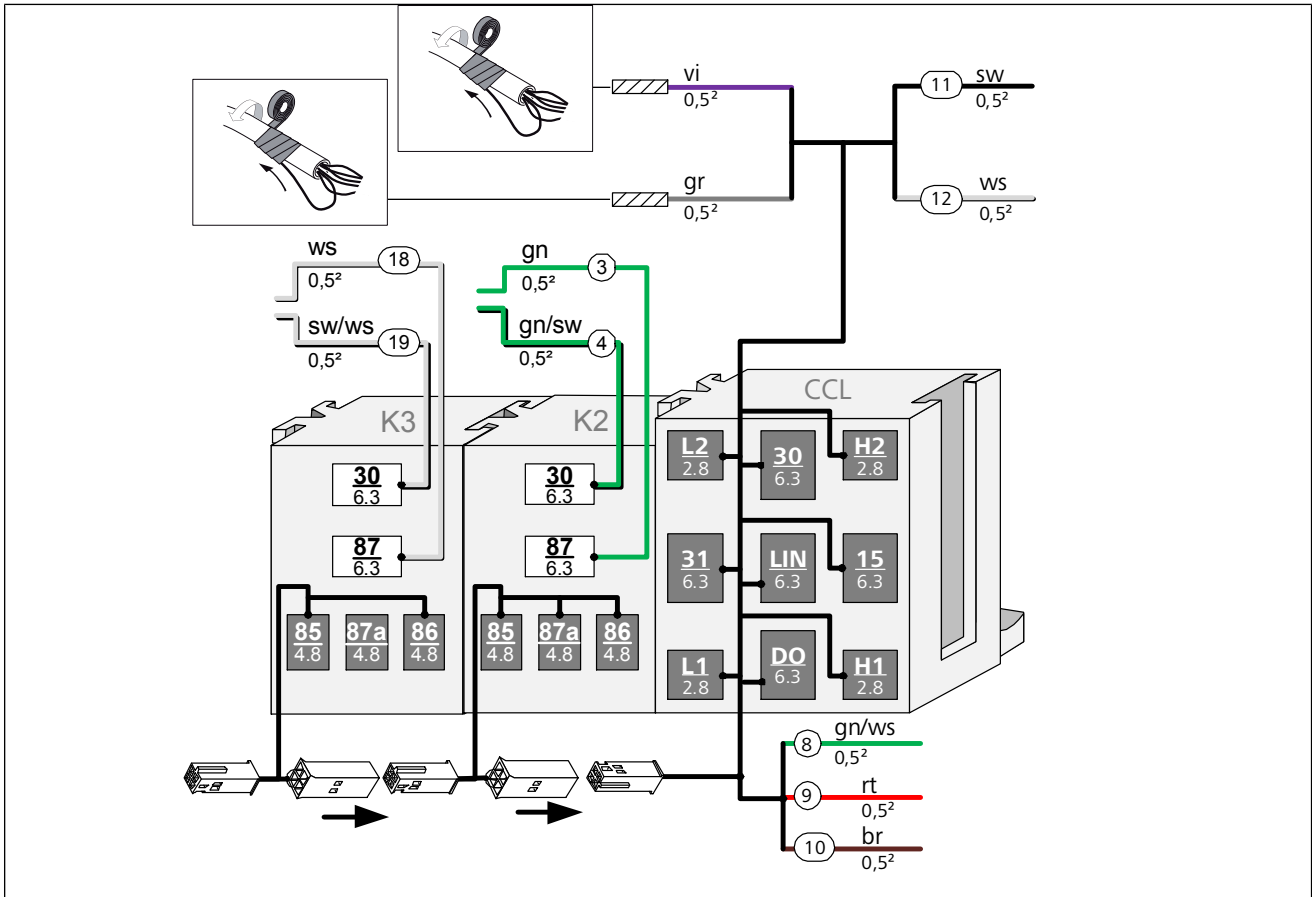

Fig. 89

Enlarging angle bracket hole

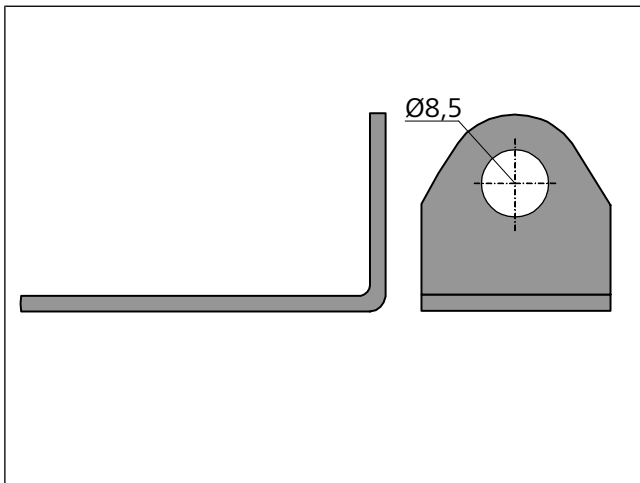

Fig. 90



Mounting angle bracket

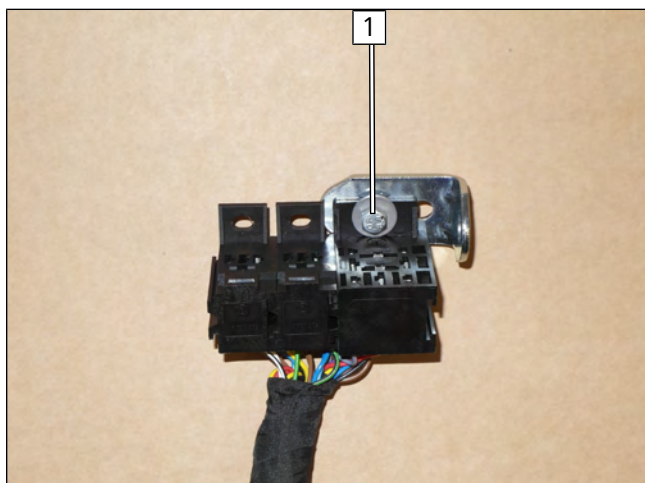

Fig. 91

- 1 M5x12 bolt, large diameter washer, prepared socket, angle bracket, large diameter washer, nut

14.2 Installation of CCL with Telestart option

Adapting perforated bracket

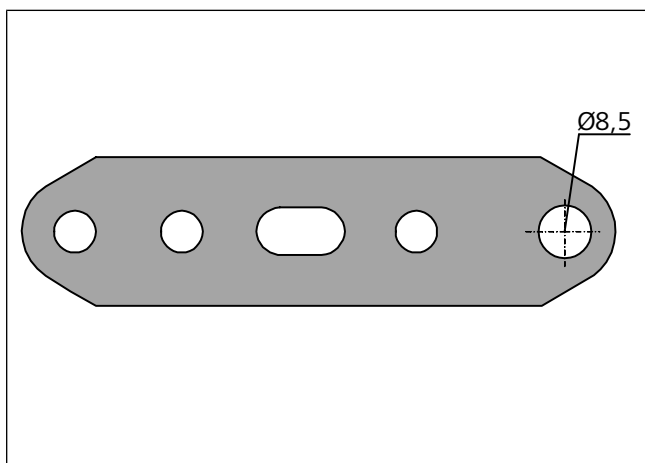

Fig. 92

Installing perforated bracket

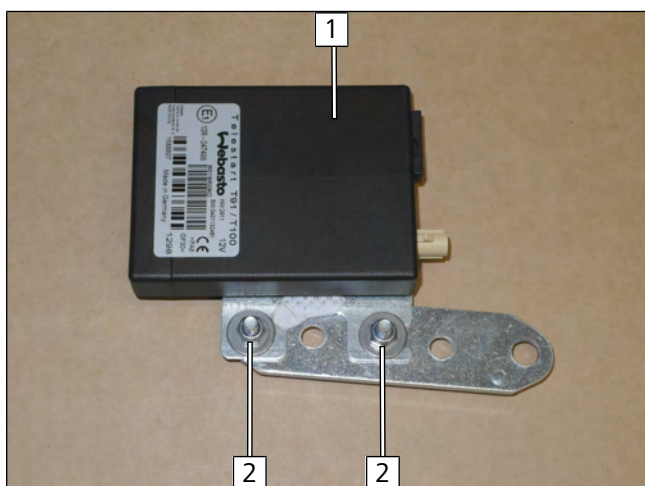

Fig. 93

► Align perforated bracket as shown.

- 1 Telestart receiver
- 2 M5x16 bolt, large diameter washer, perforated bracket, Telestart bracket, large diameter washer, nut



Cut the foam in half

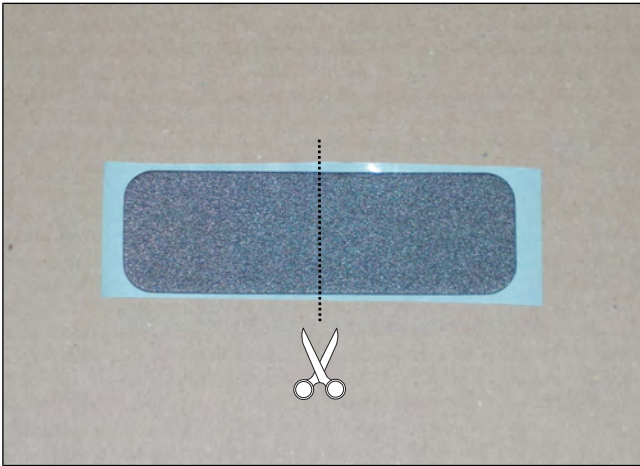

Fig. 94

Mounting relay block, gluing foam

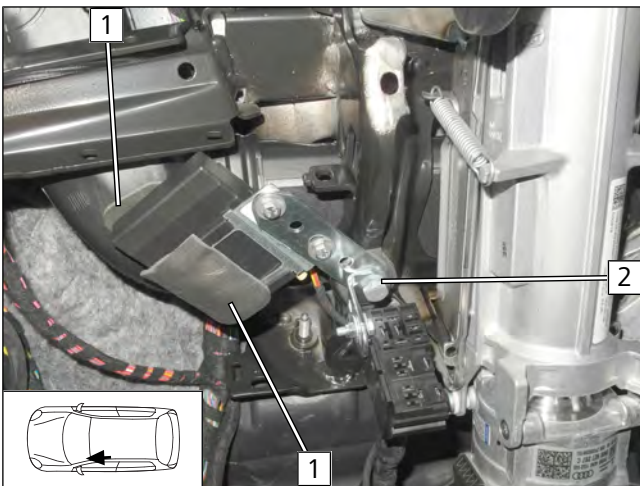

Fig. 95



Observe the Telestart installation documentation.

- 1 Foam
- 2 M8x20 bolt, spring lock washer, angle bracket, perforated bracket, original vehicle thread

Mounting temperature sensor, only in case of T100 HTM

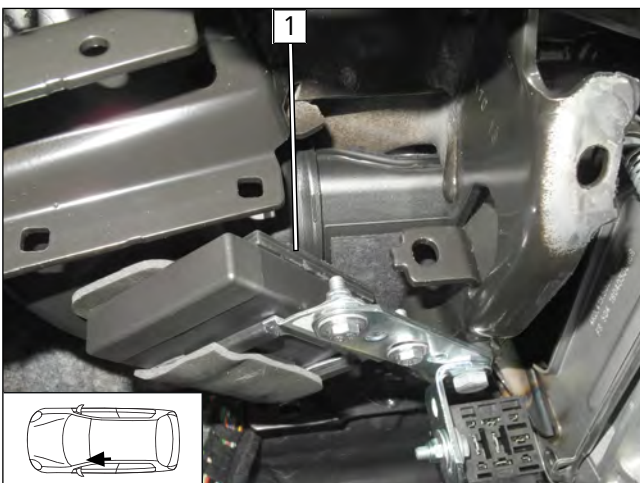

Fig. 96

► Fasten temperature sensor **1** with double-sided adhesive tape.



Mounting CCL and relay

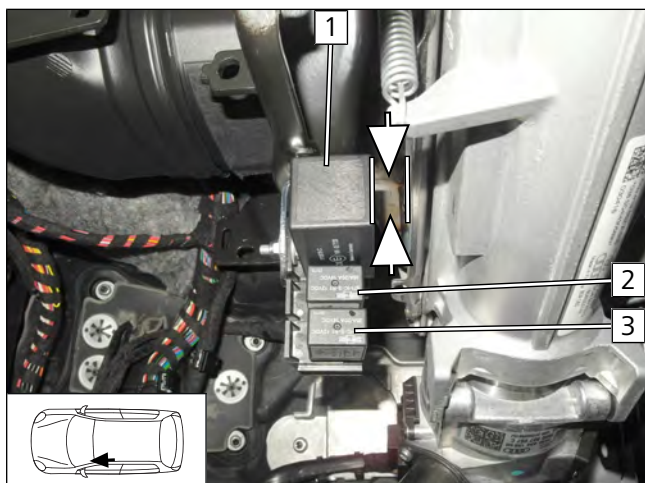

Fig. 97



Danger of damage to components
Ensure sufficient distance to steering column,
correct if necessary.



- 1 CCL
- 2 Relay K2
- 3 Relay K3

Mounting aerial

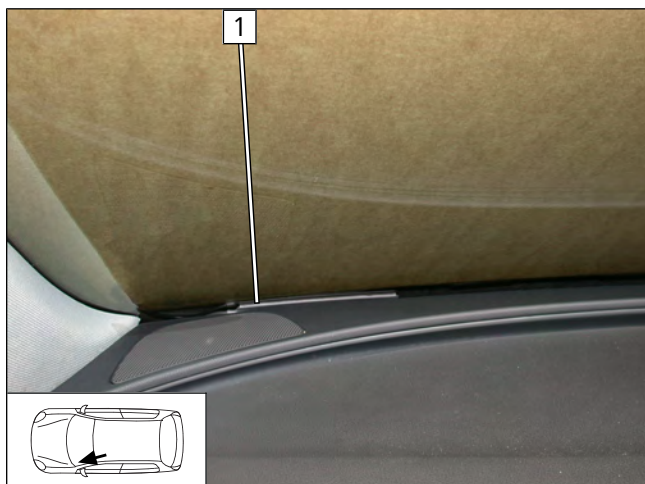

Fig. 98

- 1 Aerial

14.3 Installation of CCL with ThermoCall option

Mounting relay block

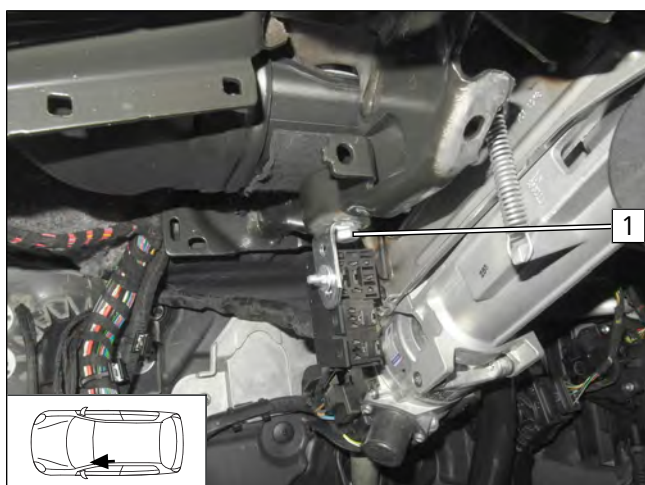

Fig. 99

- 1 M8x20 bolt, spring lock washer. Angle bracket,
original vehicle thread



Mounting CCL and relay

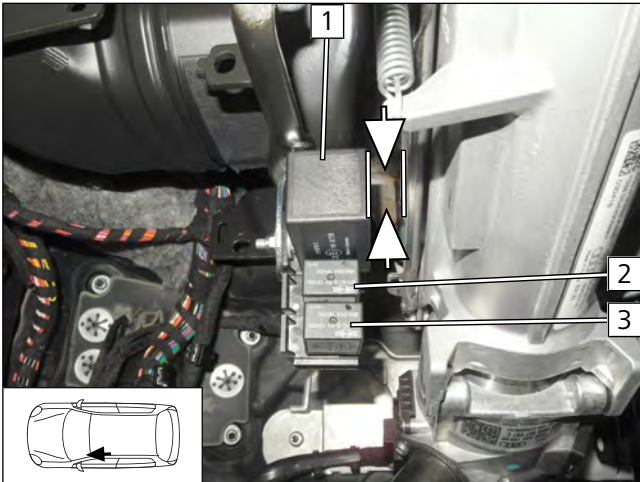
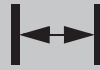

Fig. 100



Danger of damage to components

Ensure sufficient distance to steering column, correct if necessary.



- 1 CCL
- 2 Relay K2
- 3 Relay K3

Mounting receiver

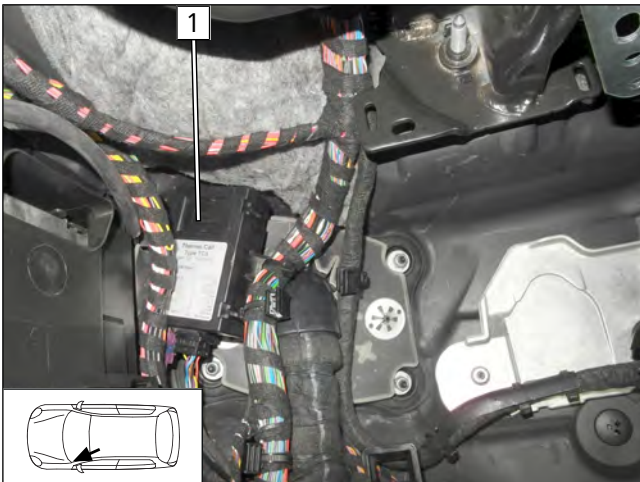

Fig. 101



Observe the ThermoCall installation documentation.

- Fasten receiver 1 using double-sided adhesive tape.

Mounting aerial

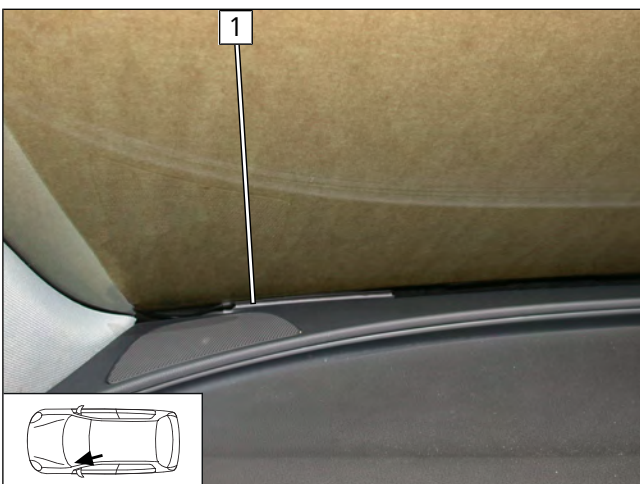

Fig. 102

- 1 Aerial



14.4 Wiring diagram

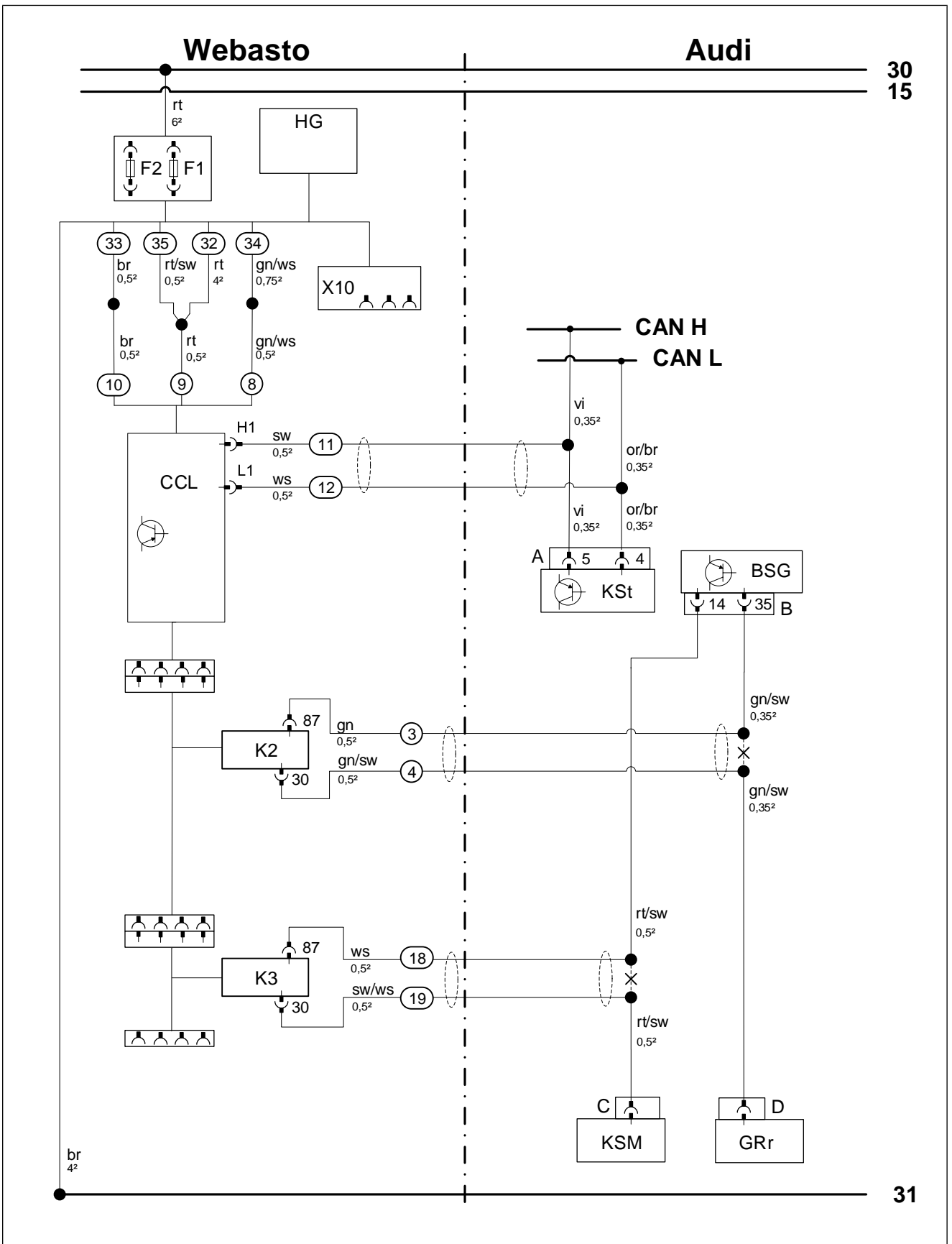

Fig. 103



Legend to wiring diagram



The vehicle connector and component designations are freely chosen by Webasto.
Cable colours may vary.

Vehicle components		Symbols	
Abbreviation	Component	Abbreviation	Designation
Kst	Coupling point	X	Cutting point
A	17-pin Kst connector		
BSG	Body control module		
B	54-pin BSG connector		
KSM	Flap positioning motor		
C	KSM connector		
GRr	Fan controller		
D	GRr connector		

Webasto components		Cable colours	
Abbreviation	Component	Abbreviation	Colour
A	Male plug for CLR module wiring harness	bg	beige
B	Female plug for CLR module wiring harness	bl	blue
C	Male plug for adapter wiring harness	br	brown
D	Female plug for adapter wiring harness	dbl	dark blue
E	Male plug for Plug&Play wiring harness	dgn	dark green
F	Female plug for Plug&Play wiring harness	ge	yellow
CCL GW	Micro Gateway CAN CAN LIN	gn	green
CL GW	Micro SPS CAN / WBus (Gateway CAN LIN)	gr	grey
CLR	CAN LIN Rxx (cold start module)	hbl	light blue
D1	Diode	hgn	light green
D2	Diode group	la	salmon
F0	Additional fuse for power supply	or	orange
F1	Heater main fuse	pk	pink
F2	Passenger compartment fan controller main fuse	ro	Pink
F3	Control element fuse	rt	red
F4	Fan controller fuse	sw	black
F5	Additional fuse	vi	violet
HG	Heater TT-Evo	ws	white
K1	Relay K1		
K2	Relay K2		
K3	Relay K3		
LA	Power adapter		
LIN GW	LIN Gateway		
MV	Solenoid valve		
PWM GW	LIN Gateway / PWM (pulse width modulator)		
RSH	Relay and fuse holder of passenger compartment		
RTD	Temperature sensor		
X10	Female plug for control element		



14.5 Fan controller

View of connector B

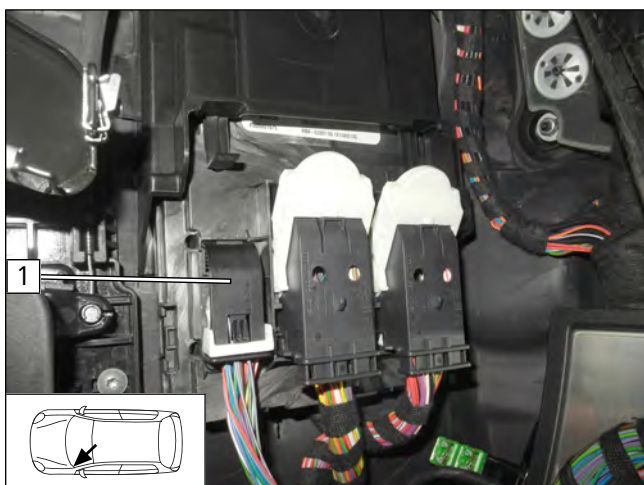

Fig. 104

- 1 54-pin BSG connector B

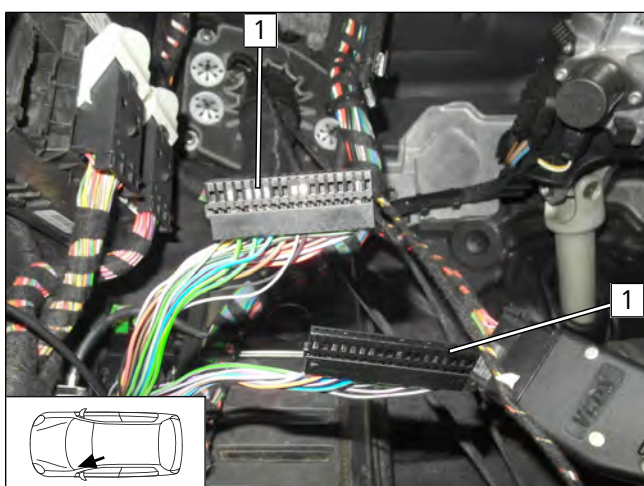

Fig. 105

- 1 54-pin BSG connector B, disconnected

Connecting relays K2 and K3

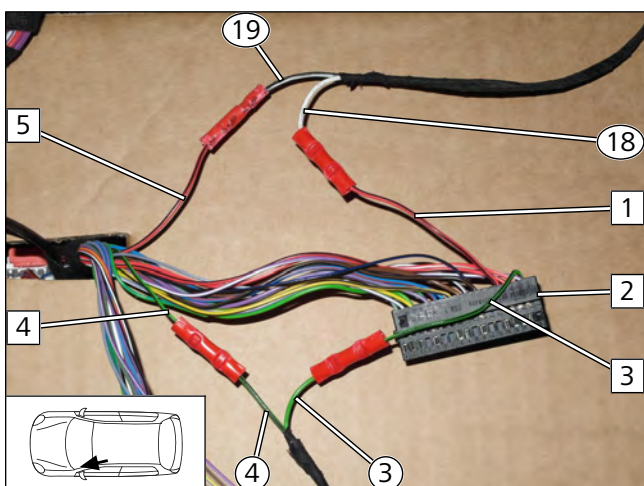

Fig. 106



Produce all following electrical connections as shown in the system wiring diagram.

- 1 Red/black (rt/sw) wire of connector B/pin 14
- 2 54-pin connector B
- 3 Green/black (gn/sw) wire of connector B/pin 35
- 4 Green/black (gn/sw) wire of connector D
- 5 Red/black (rt/sw) wire of connector C
- 3 Green (gn) wire of K2/87 from LIN control wiring harness
- 4 Green/black (gn/sw) wire of K2/30 from LIN control wiring harness
- 18 White (ws) wire of K3/87 from isolating relay wiring harness
- 19 Black/white (sw/ws) wire of K3/30 from isolating relay wiring harness



View of connector A

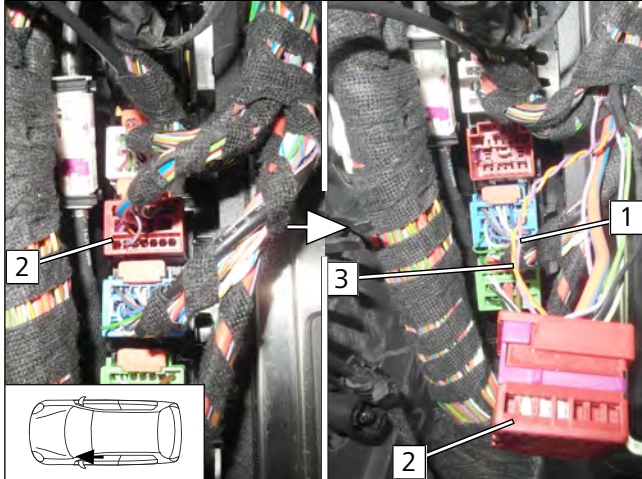

Fig. 107

- 1 Violet (vi) wire of connector A/pin 5
- 2 17-pin Kst connector A
- 3 Orange/brown (or/br) wire of connector A/pin 4

Connecting CCL

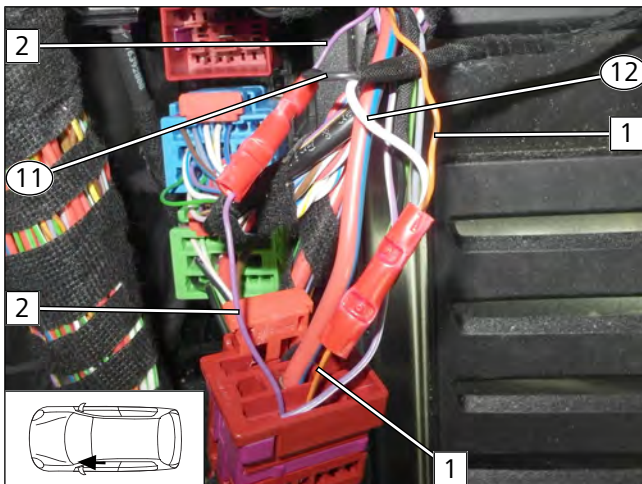

Fig. 108

- 1 Orange/brown (or/br) wire of connector A/pin 4
- 2 Violet (vi) wire of connector A/pin 5
- 11 Black (sw) wire of CCL/H1
- 12 White (ws) wire of CCL/L1



Connecting HG wiring harness to CCL wiring harness in passenger compartment

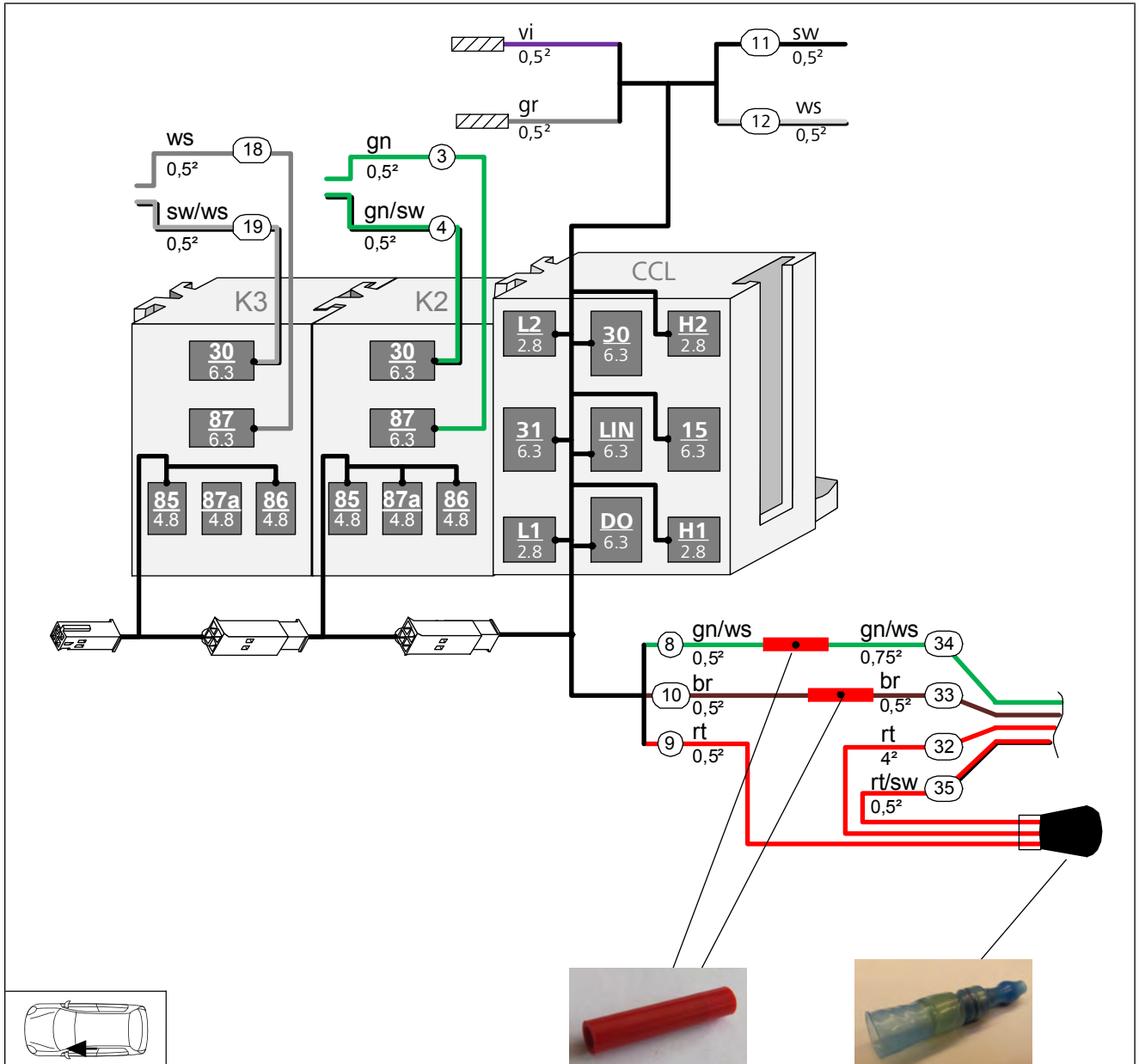

Fig. 109



15 Final Work



Further information can be found in the vehicle manufacturer's technical documentation.

- ▶ Mount removed parts in reverse order.



▶ Check all hoses, clamps and all electrical connections for firm seating.

▶ Insulate and tie back loose lines

▶ Spray heater and electrical components with anti-corrosion wax (Tectyl 100K).

▶ Connect the battery.



Only use manufacturer-approved coolant.

- ▶ Fill and bleed the coolant circuit according to the vehicle manufacturer's specifications.



Further information can be found in the general installation and operating instructions of the Webasto components.

▶ Program MultiControl CAR, teach Telestart transmitter

▶ Make settings on A/C control panel according to the 'Operating Instructions'.

▶ Initial operation and functional test

▶ Affix 'Switch off parking heater before refueling' caution label in area of filler neck



Vehicle event log after parking heating mode

- ✓ Components of the original vehicle air conditioning system are activated during parking heating mode. Other vehicle components remain inactive, which in some circumstances may be interpreted as an error and can be filed as such in the event log. An increased power consumption (quiescent current) may also be registered for some vehicles.

▶ If an incorrect installation can be excluded, these entries are exclusively related to the parking heating mode situation and have no effect on the vehicle functions in driving mode.

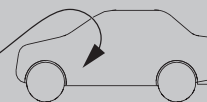
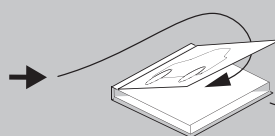
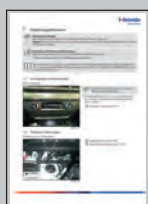
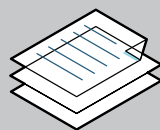

These are the original instructions. The German language is binding.
You can request your language if it is missing. The telephone number of each country can be found in the Webasto service centre leaflet or the website of the respective Webasto representative of your country.

© Copyright 2020 - The contents of this document, including but not limited to text, photographs and graphics, are protected by copyright. All rights, including reproduction, publication, editing and translation in any way, shape or form, are reserved by Webasto.

Webasto Thermo & Comfort SE
Postfach 1410
82199 Gilching
Germany

Company address:
Friedrichshafener Str. 9
82205 Gilching
Germany

Technical Extranet: <https://dealers.webasto.com>



WWW.WEBASTO.COM

16 Operating instructions



Vehicles with passenger compartment monitoring:

Further information can be found in the vehicle operating instructions.

- ▶ Deactivate passenger compartment monitoring for the heating operation



Information regarding the heating time:

We recommend matching the heating time to the driving time (heating time = driving time)

Example: for a driving time of approx. 20 min. (in one direction), we recommend not exceeding a switch-on time of 20 min.



Note for current consumption in case of parking heating mode

Depending on the vehicle model, there may be an increased quiescent current consumption message in the vehicle information system during or directly after operation in parking heating mode.

- ▶ This is not an error that can affect the vehicle on a technical level.



Notes about the active parking heating mode

The vehicle fan is deactivated when the vehicle is opened and is available again once the ignition is switched on.

After the vehicle is closed again, it can take several minutes for it to be active again.



Note for parking heater function

Your vehicle is equipped with a passenger compartment and engine preheating unit.



Notes on parking heater exhaust outlet ¹

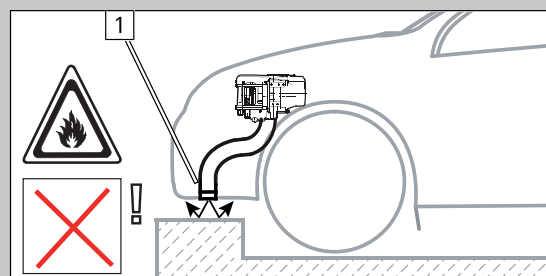
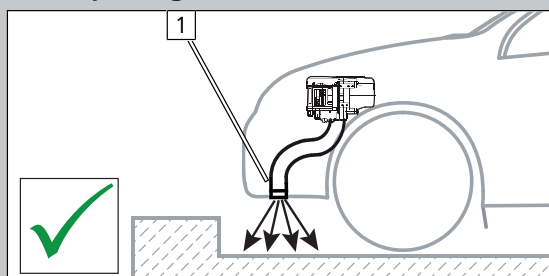

16.1 A/C control panel settings

Automatic A/C control panel



Fig. 110



Before parking the vehicle, make the following settings:



Setting the fan speed is not required, it will automatically be set to approx. 1/3.

- 1 Temperature on both sides to 'HIGH'
- 2 Air outlet on both sides to windscreen

16.2 Installation location of fuses

Fuses in engine compartment

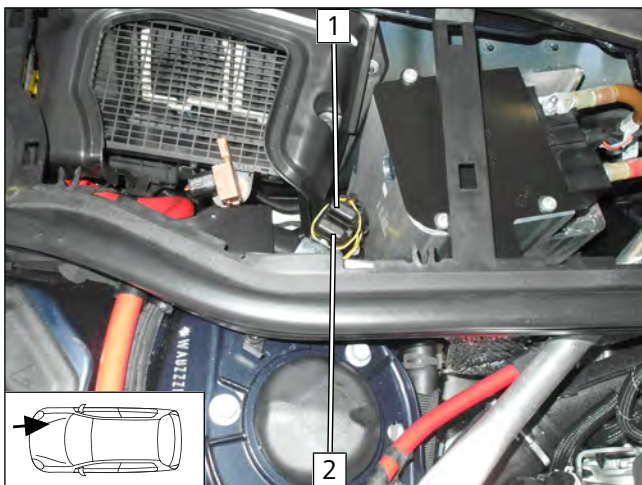

Fig. 111

- 1 F1 - 20A heater main fuse
- 2 F2 - 3A main fuse of passenger compartment