



Water heater

Thermo Top Evo parking heater



Installation documentation Mercedes-Benz GLC BR253

Validity

Manufacturer	Model	Type	Model year	EG BE No. / ABE
Mercedes-Benz	GLC	X253	from 2019	e1 * 2001 / 116 * 0480 * ...
Mercedes-Benz	GLC Coupé	C253	from 2019	e1 * 2001 / 116 * 0480 * ...

Motorisation	Fuel	Emission standard	Transmission type	Output in kW	Displacement in cm ³	Engine code
GLC 300	Petrol	Euro 6d-Temp	AG	190	1991	M264

AG = automatic transmission

Left-hand drive vehicle

Verified equipment variants: THERMATIC with 2-zone automatic air-conditioning (code 580)
 THERMOTRONIC with 3-zone automatic air-conditioning (Code 581)
 LED main headlights
 4MATIC
 Headlight washer system
 Air-conditioning system with R1234yf refrigerant (alternative refrigerant code 2U8)
 48 V additional battery
 66 l tank (code 916)
 AMG Line Exterior (code P31)
 AMG Styling (code 772)
 Wheel arch extensions (code 776)
 Heated window washer system (code 875)
 Keyless Go (code 889 / code P17)

Not verified: Alarm system
 Passenger compartment monitoring

Total installation time: approx. 10.0 hours

Mercedes-Benz GLC BR253

Table of contents

Validity	1	Preparing heater	11
Necessary components	2	Installing heater	13
Installation overview	2	Exhaust gas	15
Information on total installation time	2	Coolant circuit	17
Information on operating and installation instructions	3	Fuel	23
Information on validity	4	Installing FuelFix	25
Technical information	4	Combustion air	30
Explanatory notes on document	4	Final work	31
Preliminary work	5	FuelFix template	33
Heater installation location	5		
Electrical system	6		
Air-conditioning control	8		
Control element installation	8		
Preparing installation location	9		

Necessary components

Description	Order No.:
Basic delivery scope of Thermo Top Evo	In accordance with price list
Installation kit for Mercedes-Benz GLC BR253 2019 Petrol	1324966D
Additional 'Webasto Comfort' A/C control kit for Mercedes-Benz C-Class / GLC	1324395_
In case of Telearstart, control element, as well as indicator lamp in consultation with end customer	In accordance with price list

Installation instructions

Arrange for the vehicle to be delivered with the tank only about ¼ full.

The installation location of the push button in case of Telearstart or ThermoCall should be confirmed with the end customer.

The installation location of the MultiControl CAR option should be confirmed with the end customer.

Installation overview

Legend:

1. Heater
2. Engine compartment fuse holder
3. Coolant pump
4. Female plug of control element X10
5. Fuel pump
6. FuelFix

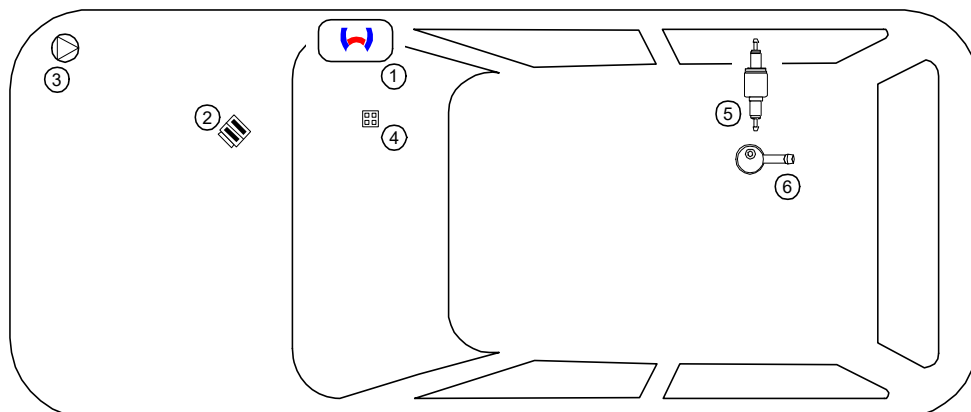

Information on total installation time

The total installation time includes the time needed for mounting and demounting the vehicle-specific components, the heater specific installation time and all other times required for the system integration and initial start-up of the heater. The total installation time may vary for vehicle equipment other than provided.

Information on operating and installation instructions

1 Important information (not complete)

1.1 Installation and repair



The improper installation or repair of Webasto heating and cooling systems can cause fire or the leakage of deadly carbon monoxide, leading to serious injury or death.



To install and repair Webasto heating and cooling systems you need to have completed a special company training course and have the appropriate technical documentation, special tools and special equipment.



Installation and repair may ONLY be carried out by persons trained and certified in a Webasto training course. NEVER try to install or repair Webasto heating or cooling systems if you have not completed a Webasto training course, you do not have the necessary technical skills and you do not have the technical documentation, tools and equipment available to ensure that you can complete the installation and repair work properly.

Only use genuine Webasto parts. See the Webasto air and water heaters accessories catalogue for this purpose.

1.2 Operation

To ensure safe operation, we recommend having the heater checked every two years by an authorised Webasto dealer, especially when used over a long period and/or under extreme environmental conditions.

Do not operate the heater in closed rooms due to the danger of poisoning and suffocation.

Always switch off the heater before refuelling.

The heater may only be used with the prescribed fuel diesel (DIN EN 590) or petrol (DIN EN 228).

The heater may not be cleaned with a high-pressure cleaner.

1.3 Please note

ALWAYS follow all Webasto installation and operating instructions and observe all warnings.

To become familiar with and understand all functions and properties of the heater, the operating instructions must be read carefully and observed at all times.

For proper, safe installation and repair work, the installation instructions with all warnings and safety information must be carefully read and observed at all times. Please always contact a workshop authorised by Webasto for all installation and repair work.

Important

Webasto shall assume no liability for defects, damage and injuries resulting from a failure to observe the installation, repair and operating instructions of the information contained in them.

This liability exclusion particularly applies to improper installations and repairs, installations and repairs by untrained persons or in the case of a failure to use genuine spare parts.

The liability due to culpable disregard to life, limb or health and due to damage or injuries caused by a wilful or reckless breach of duty remain unaffected, as does the obligatory product liability.

Installation should be carried out according to the general, standard rules of technology. Unless specified otherwise, fasten hoses, lines and wiring harnesses to original vehicle lines and wiring harnesses using cable ties. Insulate loose wire ends and tie back. Connectors on electronic components must audibly snap into place during assembly.

Sharp edges should be fitted with rub protection. Spray unfinished body areas, e.g. drilled holes, with anti-corrosion wax (Tectyl 100K).

Observe the instructions and guidelines of the respective vehicle manufacturer for demounting and mounting vehicle specific components!

The initial start-up is to be executed with the Webasto Thermo Test Diagnosis.

When installing a programmable control module (e.g. a PWM Gateway), the corresponding settings must be checked or adjusted.

2 Statutory regulations governing installation

Guidelines	Thermo Top Evo
Heating Directive ECE R122	E1 00 0258
EMC Directive ECE R10	E1 04 5627

Note

The regulations of these guidelines are binding in the scope of the Directive 70/156/EEC and/or 2007/46/EC (for new vehicle models from 29/04/2009) and should also be observed in countries in which there are no special regulations.

Important

Failure to follow the installation instructions will result in the invalidation of the type approval for the heater and therefore invalidation of the general **homologation of the vehicle**.

Note

The heater is licensed in accordance with paragraph 19, section 3, No. 2b of the StVZO (German Road Traffic Licensing Authority).

2.1 Excerpt from ECE regulation 122 (heating system) paragraph 5 for the installation of the heater

Beginning of excerpt.

ANNEX VII

REQUIREMENTS FOR COMBUSTION HEATERS AND THEIR INSTALLATION

1. GENERAL REQUIREMENTS

1.7.1. A clearly visible tell-tale in the operator's field of view shall inform when the combustion heater is switched on or off.

2. VEHICLE INSTALLATION REQUIREMENTS

2.1. Scope

2.1.1. Subject to paragraph 2.1.2, combustion heaters shall be installed according to the requirements of this Annex.

2.1.2. Vehicles of category O having liquid fuel heaters are deemed to comply with the requirements of this Annex.

2.2. Positioning of heater

2.2.1. Body sections and any other components in the vicinity of the heater must be protected from excessive heat and the possibility of fuel or oil contamination.

2.2.2. The combustion heater shall not constitute a risk of fire, even in the case of overheating. This requirement shall be deemed to be fulfilled if the installation ensures an adequate distance to all parts and suitable ventilation, by the use of fire resistant materials or by the use of heat shields.

2.2.3. In the case of M2 and M3 vehicles, the heater must not be positioned in the passenger compartment. However, an installation in an effectively sealed envelope which also complies with the conditions in paragraph 2.2.2 may be used.

2.2.4. The label referred to in paragraph 1.4 or a duplicate, must be positioned so that it can be easily read when the heater is installed in the vehicle.

2.2.5. Every reasonable precaution should be taken in positioning the heater to minimise the risk of injury and damage to personal property.

2.3. Fuel supply

2.3.1. The fuel filler must not be situated in the passenger compartment and must be provided with an effective cap to prevent fuel spillage.

2.3.2. In the case of liquid fuel heaters, where a supply separate to that of the vehicle is provided, the type of fuel and its filler point must be clearly labelled.

2.3.3. A notice, indicating that the heater must be shut down before refuelling, must be affixed to the fuelling point. In addition a suitable instruction must be included in the manufacturer's operating manual.

2.4. Exhaust system

2.4.1. The exhaust outlet must be located so as to prevent emissions from entering the vehicle through ventilators, heated air inlets or opening windows.

2.5. Combustion air inlet

2.5.1. The air for the combustion chamber of the heater must not be drawn from the passenger compartment of the vehicle.

2.5.2. The air inlet must be so positioned or guarded that blocking by rubbish or luggage is unlikely.

2.6. Heating air inlet

2.6.1. The heating air supply may be fresh or recirculated air and must be drawn from a clean area not likely to be contaminated by exhaust fumes emitted either by the propulsion engine, the combustion heater or any other vehicle source.

2.6.2. The inlet duct must be protected by mesh or other suitable means.

2.7. Heating air outlet

2.7.1. Any ducting used to route the hot air through the vehicle must be so positioned or protected that no injury or damage could be caused if it were to be touched.

2.7.2. The air outlet must be so positioned or guarded that blocking by rubbish or luggage is unlikely.

End of excerpt.

In multilingual versions the German language is binding.

Mercedes-Benz GLC BR253

Information on validity

This installation documentation applies to Mercedes-Benz GLC BR253 Petrol vehicles - for validity, see page 1 - from model year 2019 and later, assuming technical modifications to the vehicle do not affect installation, any liability claims excluded. Depending on the vehicle version and equipment, modifications may be necessary during installation with respect to this installation documentation.

Vehicle and engine types, equipment variants and other specifications not listed in this installation documentation have not been tested. However, installation according to this installation documentation may be possible.

Technical information

Special tools

- Hose clamp pliers for auto-tightening hose clamps
- Hose clamp pliers for Clic hose clamps of type W
- Automatic wire stripper, 0.2 - 6mm²
- Crimping pliers for male connector, 0.14 - 6mm²
- Crimping pliers for cable lug, 0.5 - 10mm²
- Crimping pliers for connector, 0.25 - 6mm²
- Torque wrench for 2.0 - 10 Nm
- Hose clamping pliers
- Deep-hole marker
- Metric thread-setter kit
- Webasto Thermo Test Diagnosis with current software

Dimensions

- All dimensions are in mm.

Tightening torque values

- Tightening torque values of 5x13 heater bolts and 5x11 heater stud bolts = 8Nm.
- Tightening torque value of 5x15 water connection piece retaining plate bolt = 7Nm.
- Tighten other bolt connections in accordance with manufacturer's instructions or in accordance with state-of-the-art technology.

Explanatory notes on document

You will find an identification mark on the outside top right corner of the page in question to provide you with a quick overview of the individual working steps.

Special features are highlighted using the following symbols:

Mechanical system



Electrical system



Coolant circuit



Combustion air



Fuel



Exhaust gas



Software



Specific risk of damage to components.



Specific risk due to electrical voltage.



Specific risk of injury or fatal accidents.



Specific risk of fire or explosion.



Reference to the manufacturer's vehicle-specific documents or to the general installation instructions of Webasto components.



Reference to a special technical feature.



The arrow in the vehicle icon indicates the position on the vehicle and the viewing angle.



Tightening torque according to the manufacturer's vehicle-specific documents.



Preliminary work

Vehicle



- Open the fuel tank cap.
- Ventilate the fuel tank.
- Close the fuel tank cap again.
- Depressurise the cooling system.
- Remove the right front wheel.
- Remove the wheel well trim on the right.
- Remove the lower engine cover.
- Remove the underbody trim on the right.
- Disconnect and remove the battery (not the 48 V additional battery).
- Drain off the engine coolant and set aside.
- Remove the expansion tank.
- Remove the seating area of the rear bench seat.
- Open the right-hand tank fitting service lid.

Heater

- Remove years that do not apply from the type and duplicate label.
- Attach the duplicate label (type label) visibly in the appropriate place in the engine compartment.

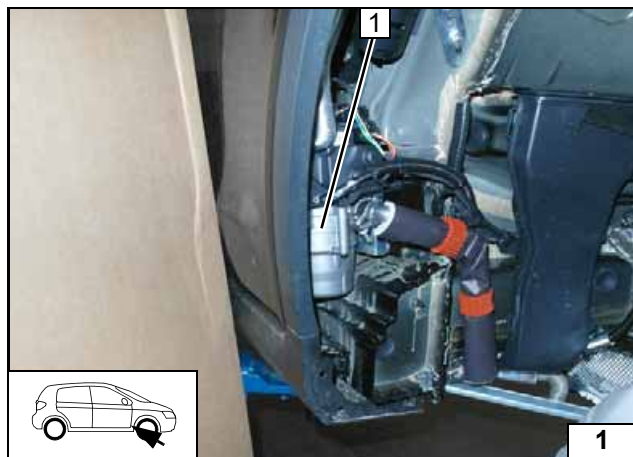

Heater installation location

- 1 Heater

Installation location



Electrical system



Earth wire

- 1 Ø8 cable lug, earth wire on original vehicle earth support point

Wiring harness pass through

- 1 Protective rubber plug, use lower perforation
- 2 Wiring harnesses of heater, control element

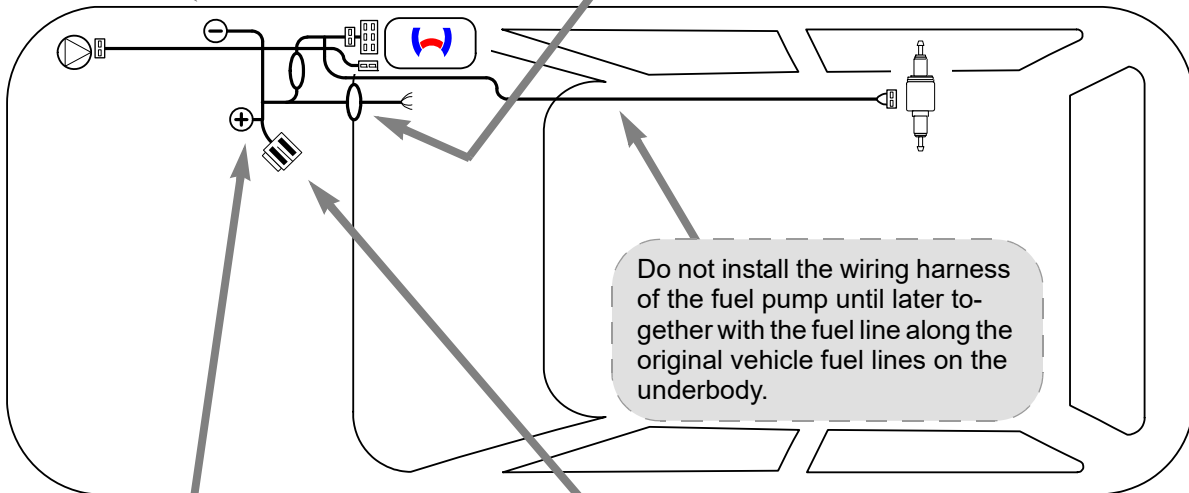
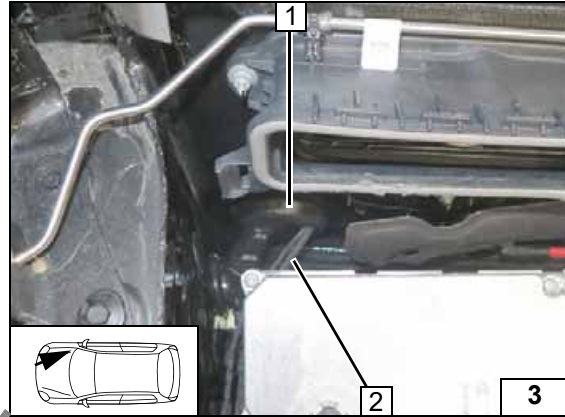
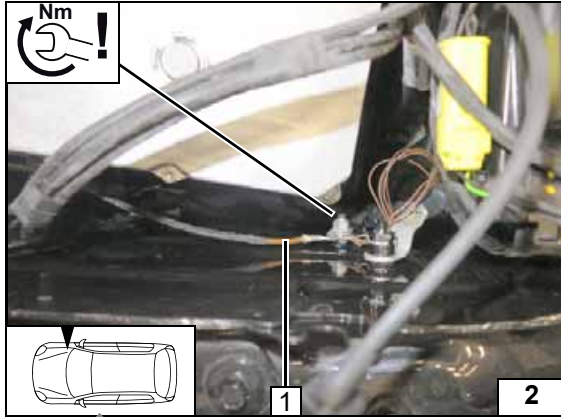

Wiring harness routing diagram

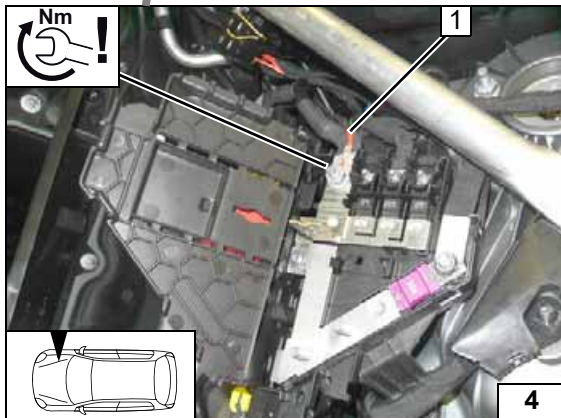

Positive wire

- 1 Ø8 cable lug, positive wire on original vehicle positive support point

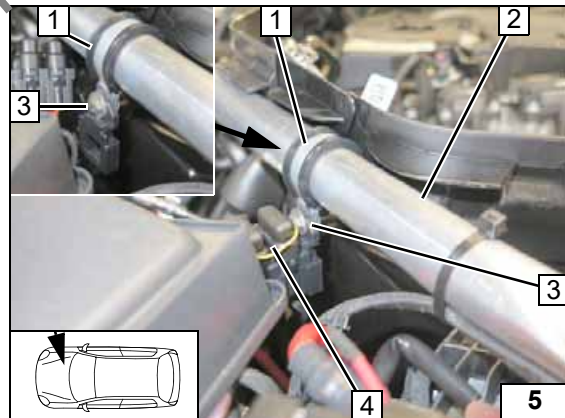

Engine compartment fuse holder

- 1 Ø29 rubber-coated p-clamp
- 2 Right engine compartment stiffening brace
- 3 M5x16 bolt, large diameter washer [2x], retaining plate of fuse holder, nut
- 4 Insert F1-2 fuses



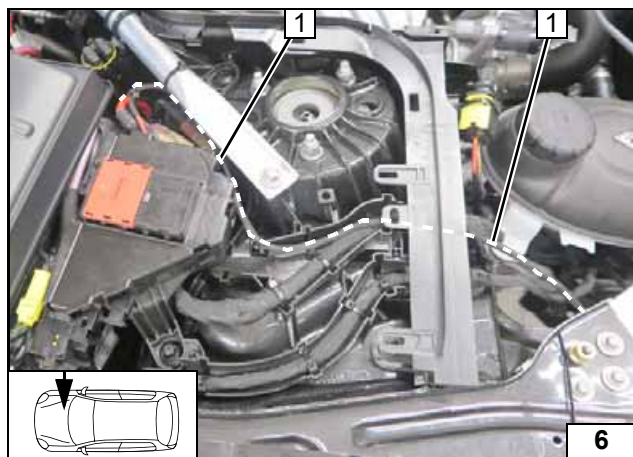

Route heater wiring harness **1** in engine compartment as shown and further to the wheel well.



Routing heater wiring harness

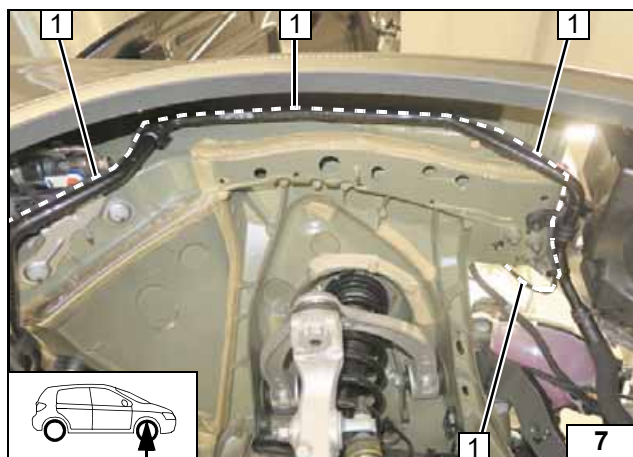

Route heater wiring harness **1** along original vehicle pipe in wheel well and further to the heater installation location. Fasten with cable ties.



Routing heater wiring harness



Air-conditioning control

! Connect the A/C control in accordance with the separate installation documentation:

'Webasto Comfort' A/C control installation documentation for Mercedes-Benz GLC BR253



Control element installation

! Install the control element in each case as explained in the provided general installation documentation.

The installation location of the optional control element MultiControl or the push button of the Telestart or ThermoCall/ThermoConnect options should be confirmed with the end customer and should comply with the installation conditions.



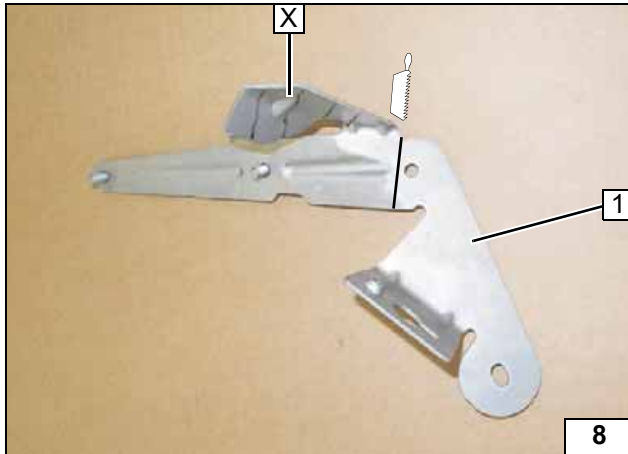
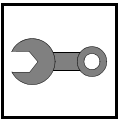

Preparing installation location

- 1 Bracket for exhaust silencer

X =



Adapting / assigning bracket

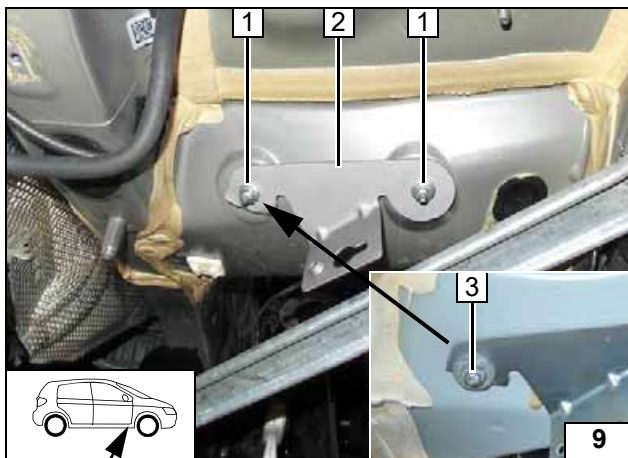

- 1 M6 flanged nut on original vehicle stud bolt [2x]
- 2 Bracket for exhaust silencer

Shorten stud bolt at position 3 as shown.



Installing bracket

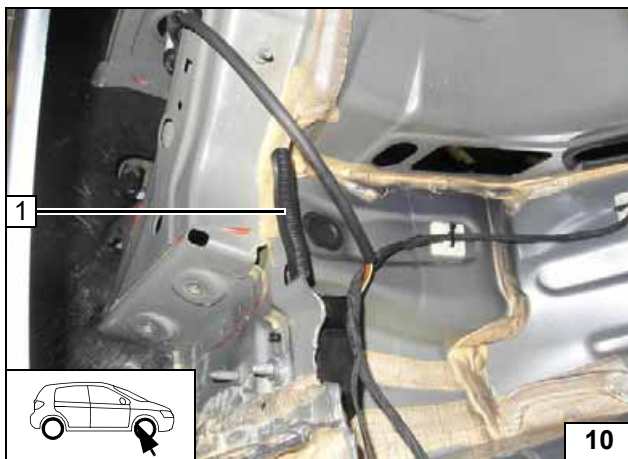

- 1 Broad edge protection (100)

Installing edge protection

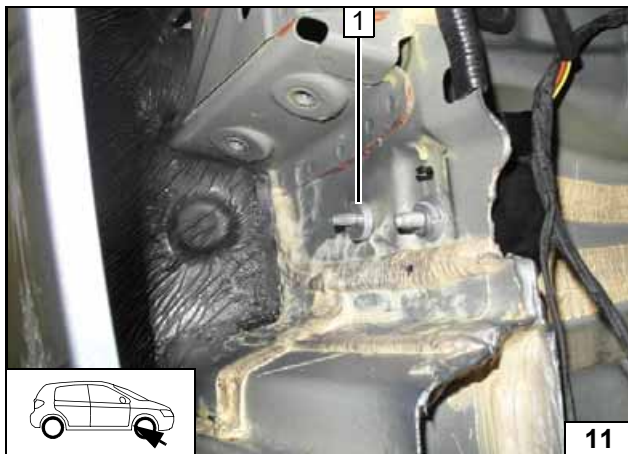

- 1 Distance washer (5) on original vehicle stud bolt

Installing distance washer

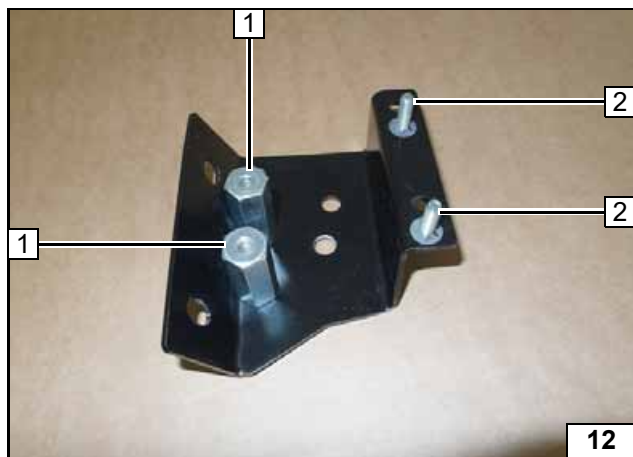
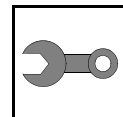

- 1 Spacer nut (40), M6x16 bolt, spring lock washer [2x each]
- 2 M6x20 bolt, lock washer [2x each]

Premounting basic holder

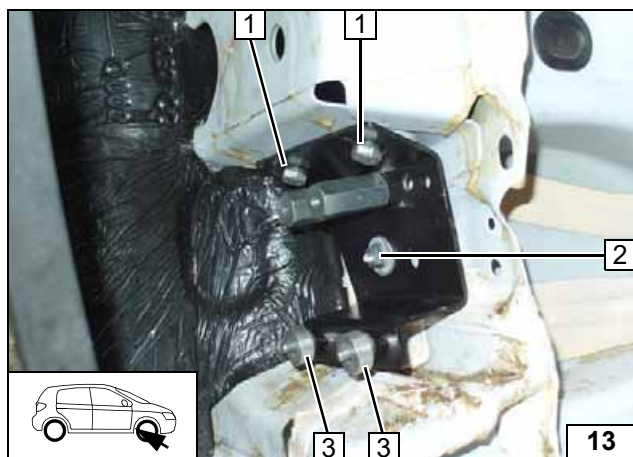

- 1 M8x20 bolt, spring lock washer, large diameter washer [2x each] at existing threaded hole
- 2 Large diameter washer, M6 flanged nut on original vehicle stud bolt
- 3 Distance washer (10) [2x]

Installing basic holder

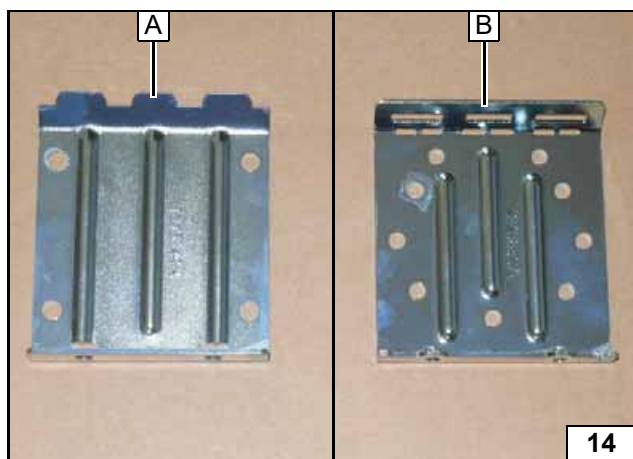

View of / assignment of two-part bracket

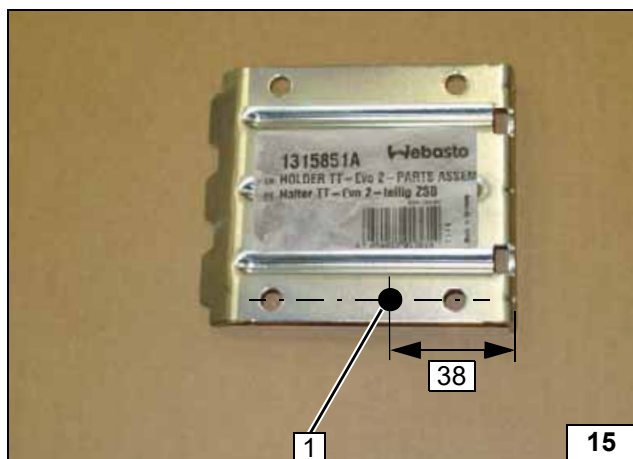

- 1 Ø7 hole

Hole in bracket A

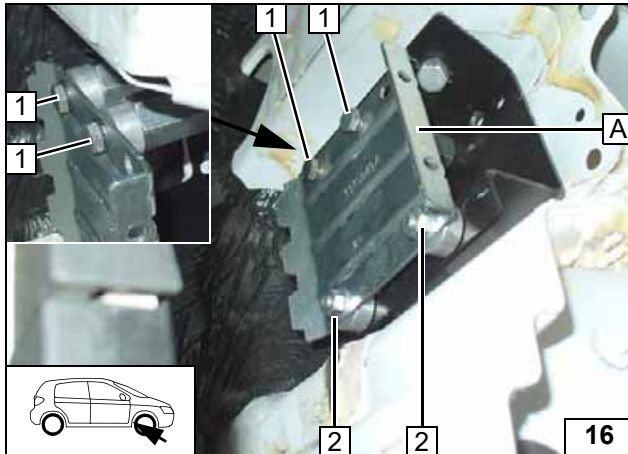
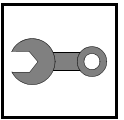

Install distance washer (10) [2x] at position 1 between basic holder and bracket **A**.

- 1 M6x20 bolt, spring lock washer, distance washer (10), spacer nut [2x each]
- 2 Flanged nut M6 [2x]



Installing bracket section A

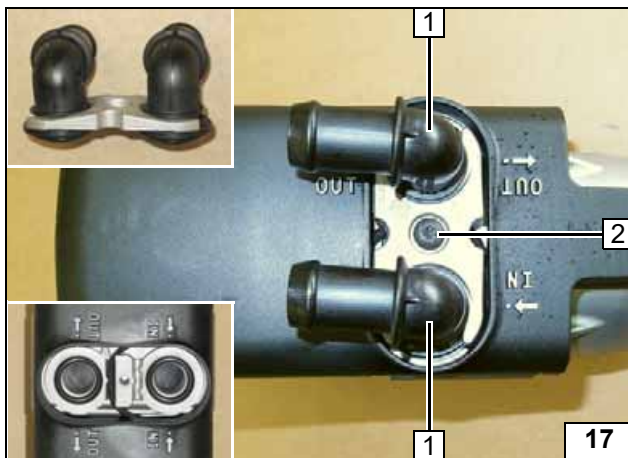

Preparing heater

All vehicles

- 1 Water connection piece, sealing ring [2x each]
- 2 5x15 self-tapping bolt, retaining plate of water connection piece



Installing water connection piece

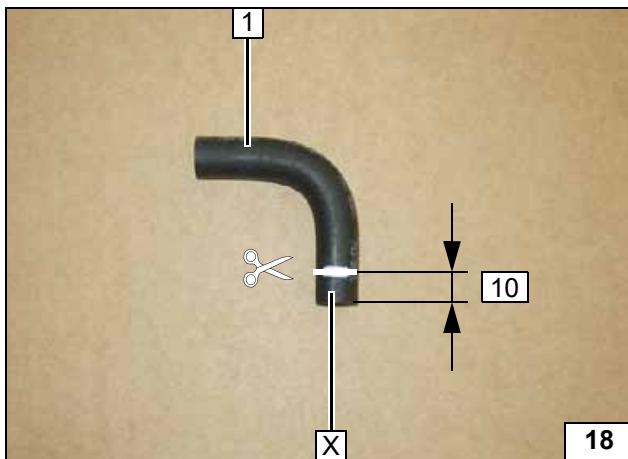

- 1 90° moulded hose

X =

Shortening moulded hose

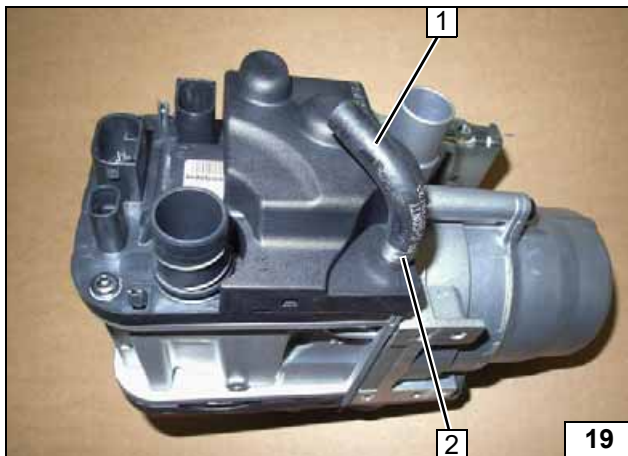

- 1 90° moulded hose (with shortened side on heater)
- 2 Ø10 clamp

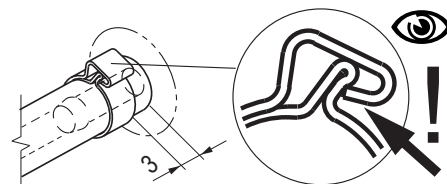

Premounting moulded hose

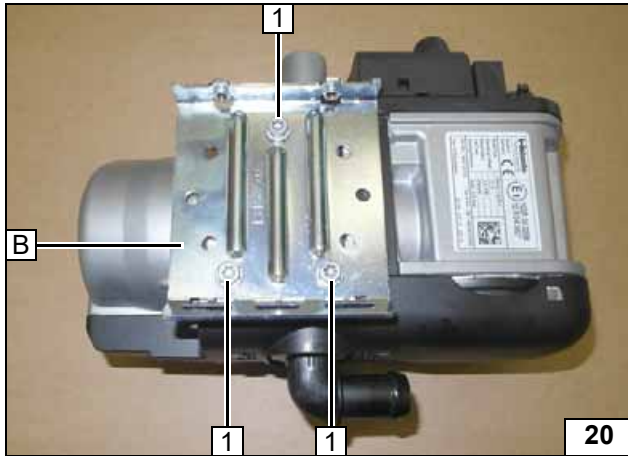
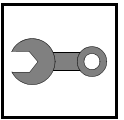

1 5x13 self-tapping bolt [3x]

Mounting bracket section B

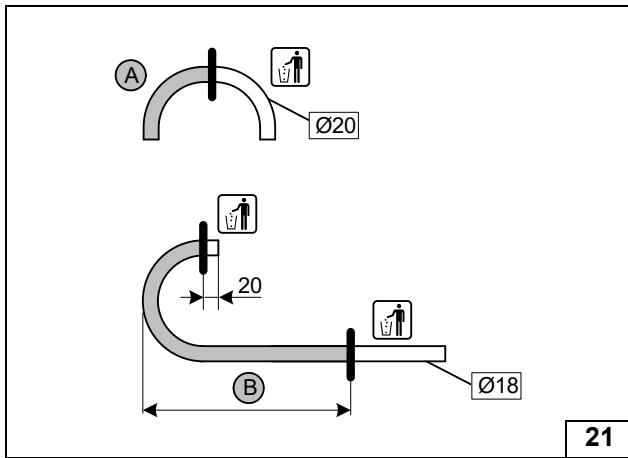

A = 90°
B = 460

Cutting hoses to length

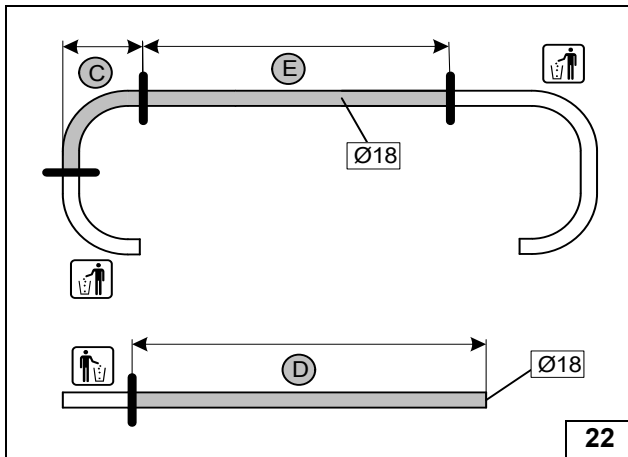

C = 90°
D = 1550
E = 1420

Cutting hoses to length

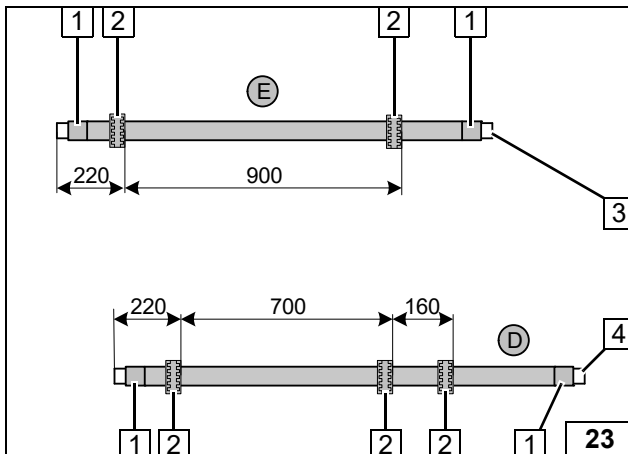

Slide braided protection hoses onto hoses **D** and **E** and cut to length. Cut heat shrink plastic tubing to size.



- 1 50 long heat shrink plastic tubing [4x]
- 2 Position black (sw) rubber isolator [5x]
- 3 Connection side of heater outlet
- 4 Connection side of heater inlet

Preparing hoses

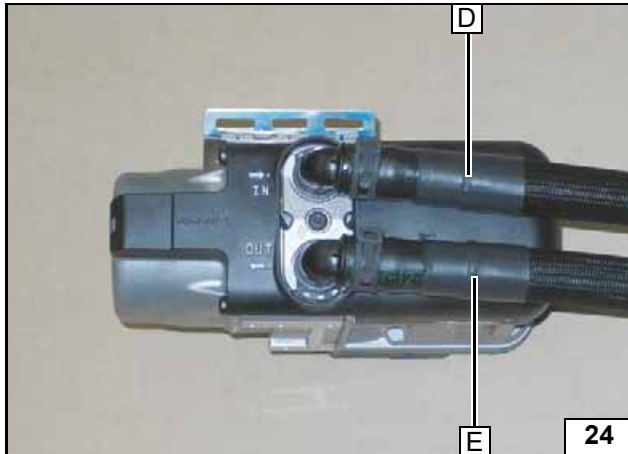
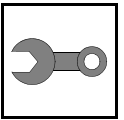

All spring clips = $\varnothing 25$



Installing hoses

Installing heater

Install heater in installation location from the front (see next figure).



Installing heater

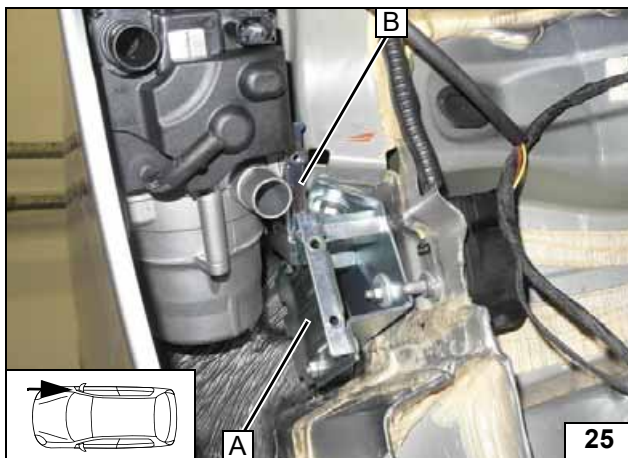

The recesses of bracket **B** must be guided over the tabs of bracket **A**.



- A** Bracket (installed on basic holder)
- B** Bracket (installed on heater)

View of bracket **A** and **B** assembly

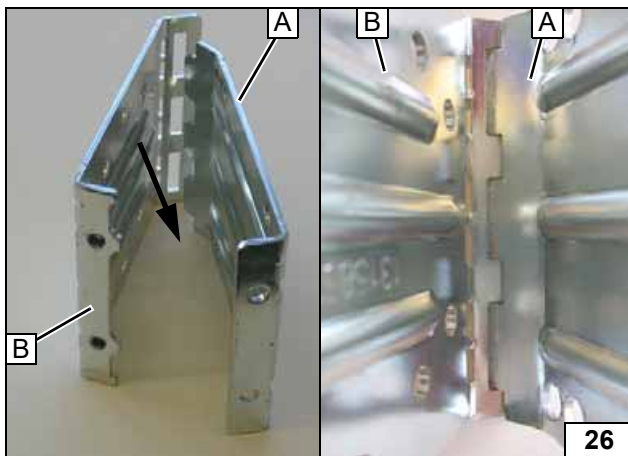

Check the assembly of bracket **B** and bracket **A**, then screw them together.



- 1 M5x12 torx screw [2x]

Installing heater

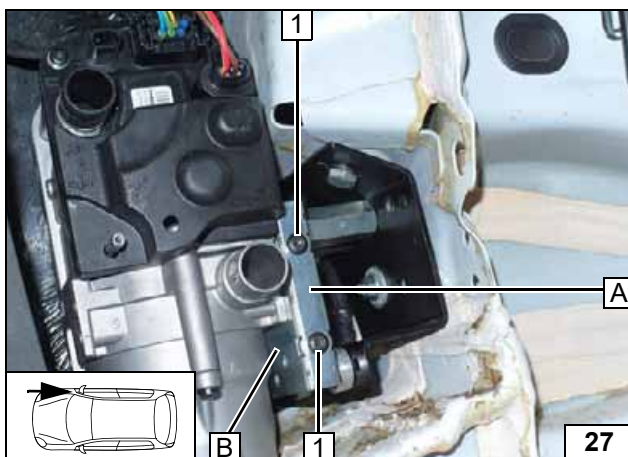

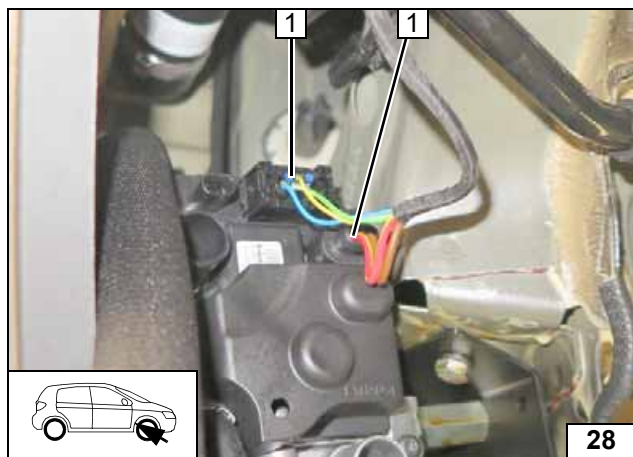
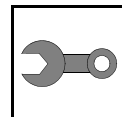

- 1 Heater wiring harness connector [2x]

Installing
heater

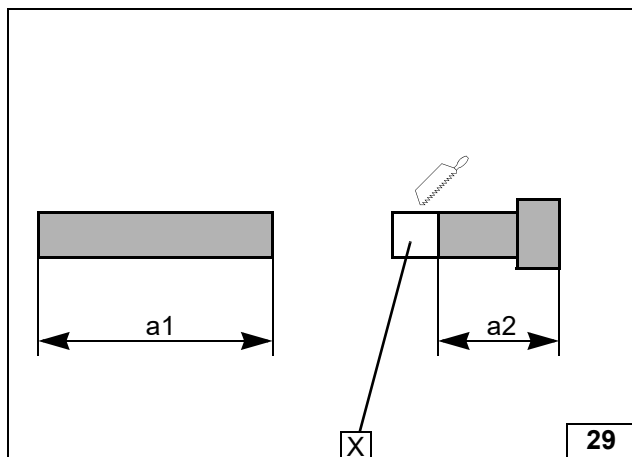
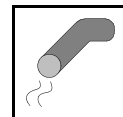

Exhaust gas

a1 = 230

a2 = 90

X =

Preparing exhaust pipe

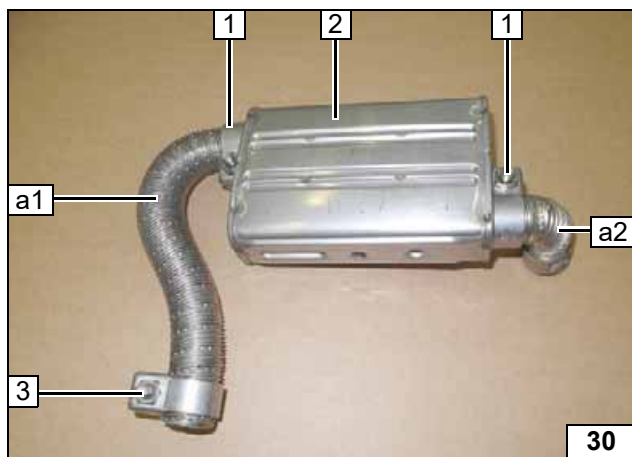

Shape exhaust pipes **a1** and **a2** as shown.



- 1 Hose clamp [2x]
- 2 Exhaust silencer
- 3 Hose clamp, loosely installed

Premounting exhaust silencer

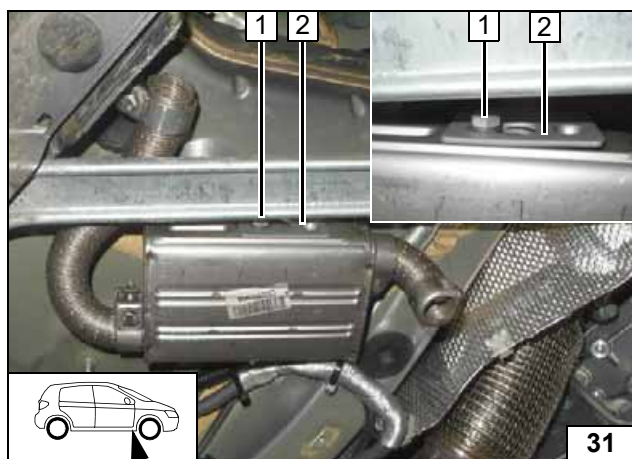

- 1 M6x16 bolt, spring lock washer
- 2 Bracket of exhaust system

Mounting exhaust silencer

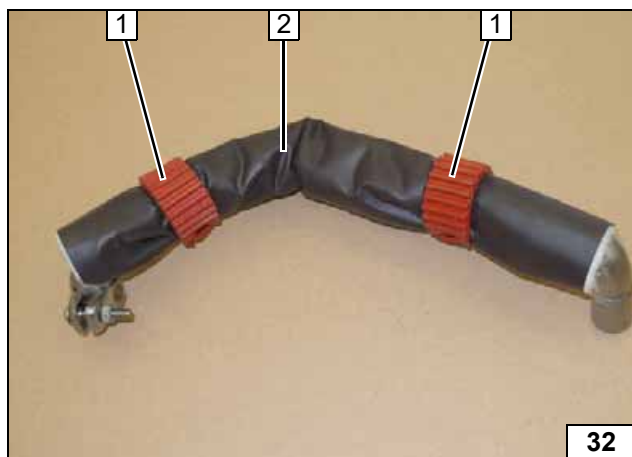

Turn locking device of silicone band **1** [2x] as shown.



- 2 Complete exhaust tube

Checking exhaust tube

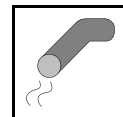

1 Tighten hose clamp

Installing exhaust tube

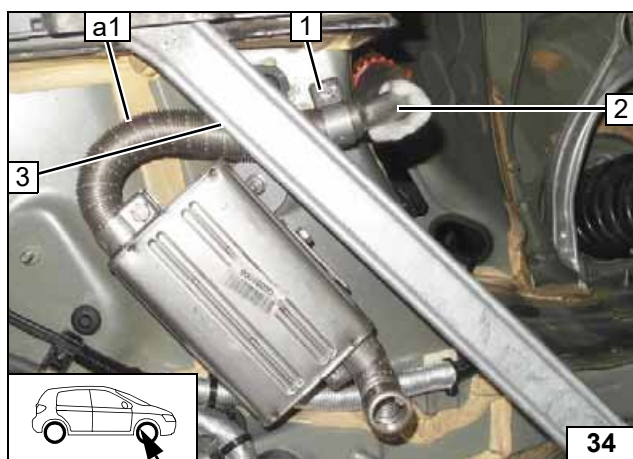

Check that there is freedom of movement between exhaust pipe a1 and cross member at position 3, correct if necessary.



- 1 Tighten hose clamp
- 2 Exhaust tube

Connect-
ing ex-
haust tube
and ex-
haust pipe
a1

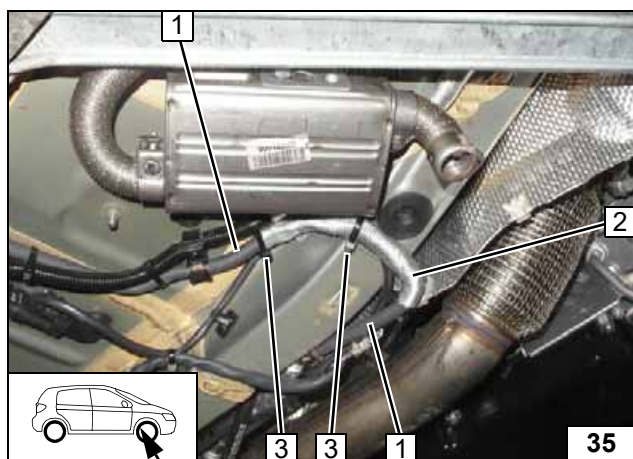

Slit 300, Ø14.5 heat protection hose 2 lengthwise, slide it over original vehicle line 1 and secure with cable tie 3 [2x].



Installing heat protec-
tion hose



Coolant circuit



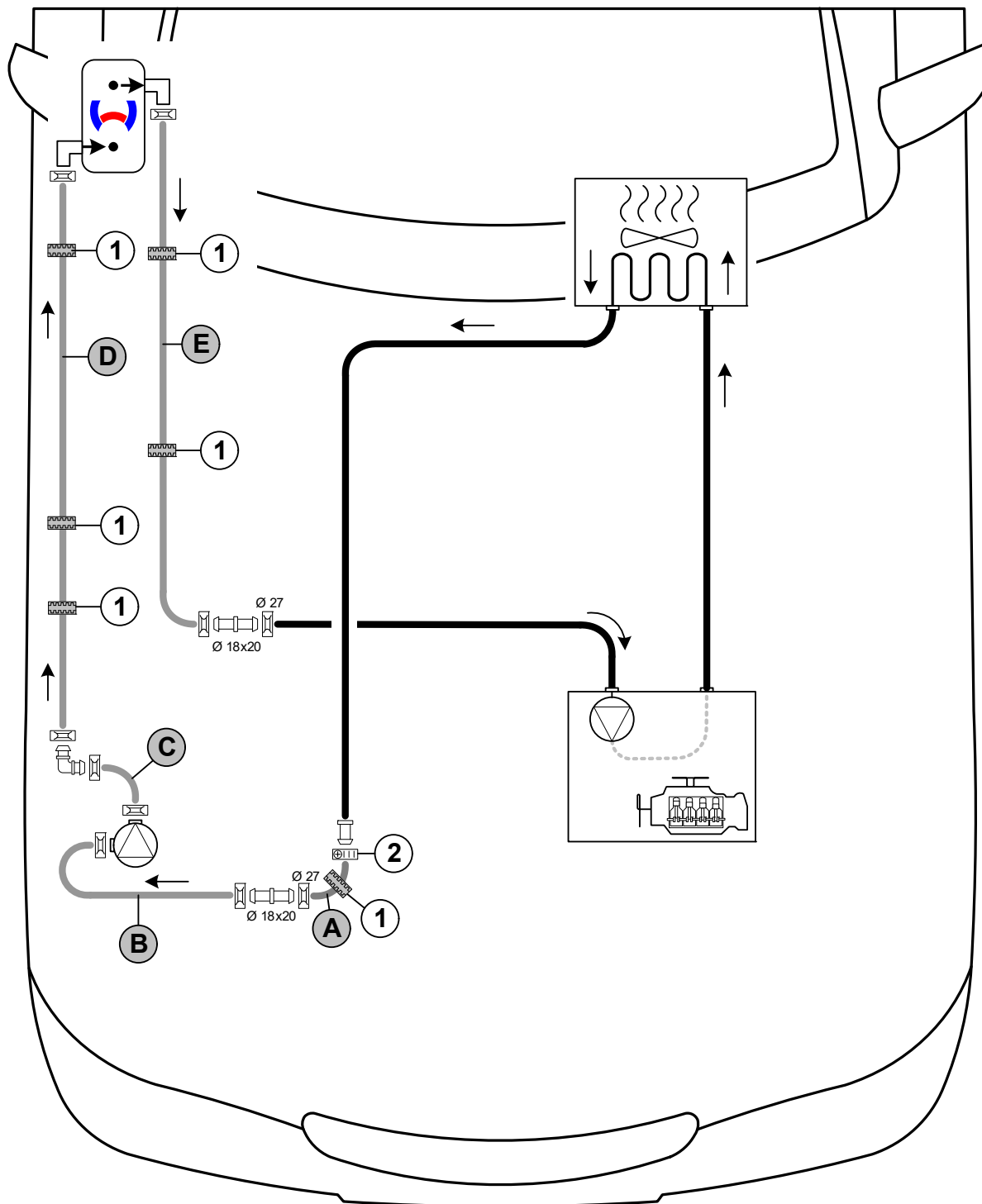

Any coolant running off should be collected in an appropriate container. Route hoses kink-free. Unless specified otherwise, always fasten using cable ties. Position clamps so that other hoses cannot be damaged. The heater must be filled with coolant when installing the hoses.

The connection should be modelled on an 'inline' circuit and based on the following diagram:



Hose routing diagram

All spring clips without a specific designation  = Ø25.

All connecting pipes without a specific designation  and  = Ø18x18.

1 = Black (sw) rubber isolator .

2 = Hose clamp  = Ø 23-35!



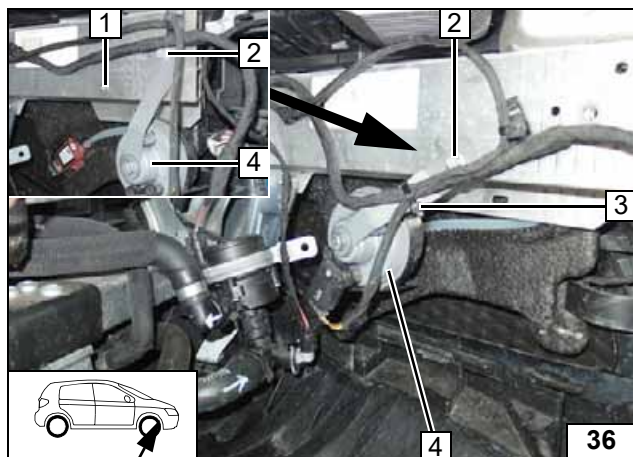

Secure original vehicle wiring harnesses using cable tie **3**.

- 1 Original vehicle thread
- 2 Original vehicle bolt on original vehicle threaded hole
- 4 Horn



Moving horn

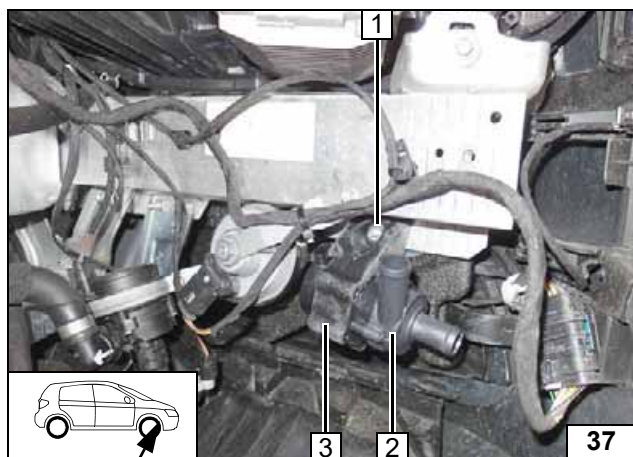

- 1 M6x25 bolt, large diameter washer, original vehicle hole, flanged nut
- 2 Coolant pump
- 3 Coolant pump mount

Mounting coolant pump

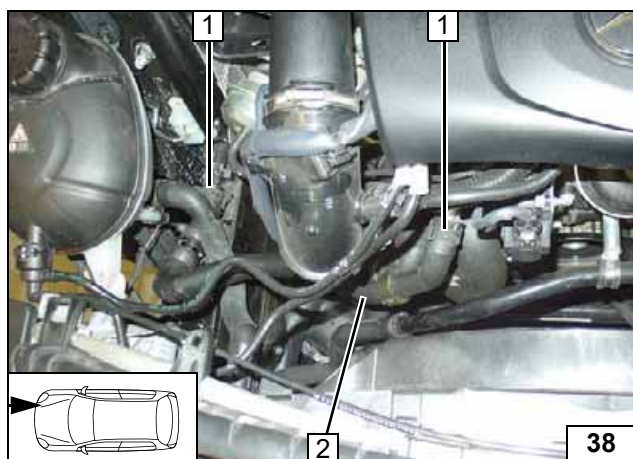

Disconnect original vehicle hose of heat exchanger outlet / engine inlet **2**. Spring clips **1** [2x] will be reused.



Disconnecting original vehicle hose

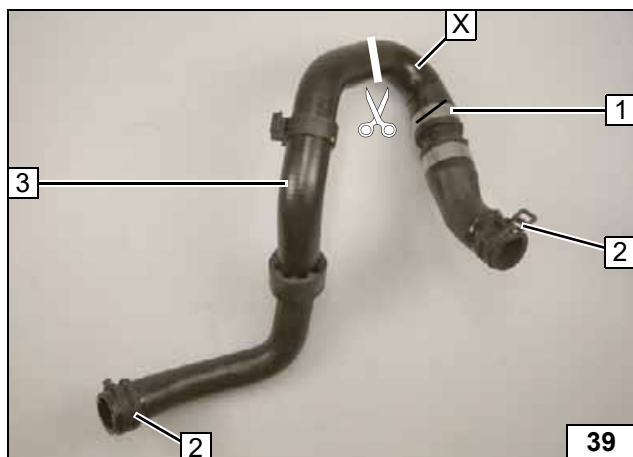

Cut original vehicle hose of heat exchanger outlet / engine inlet **3** as shown. Saw original vehicle clamp **1** carefully open and discard!

- 2 Original vehicle spring clip [2x]

X =



Cutting point

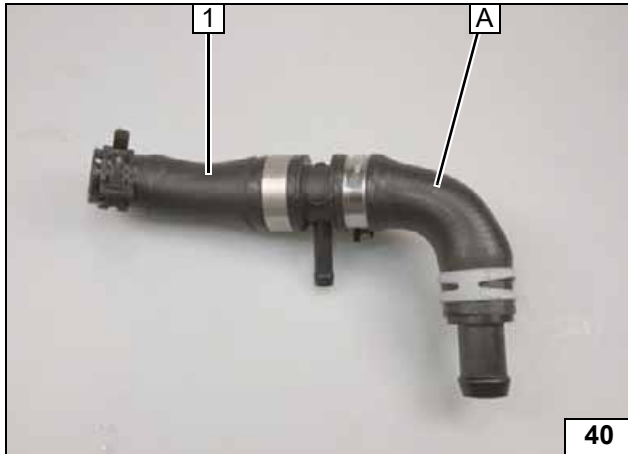
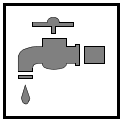

1 Hose section of heat exchanger outlet

Premounting hose section of heat exchanger outlet

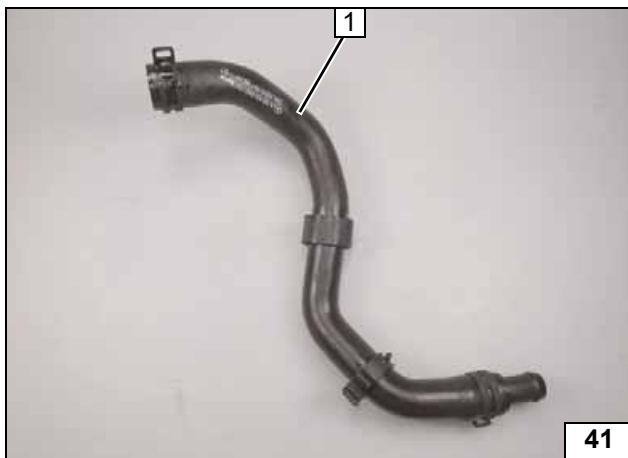

1 Hose section of engine inlet

Premounting hose section of engine inlet

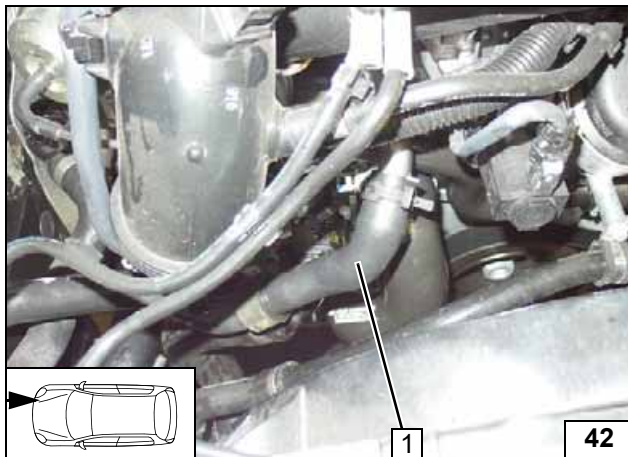

1 Hose section of engine inlet

Mounting hose section of engine inlet

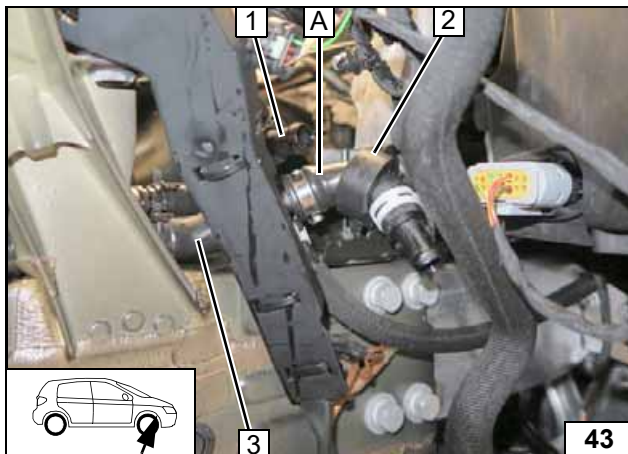

1 Hose section of engine inlet
2 Black (sw) rubber isolator
3 Hose section of heat exchanger outlet

Mounting hose section of heat exchanger outlet

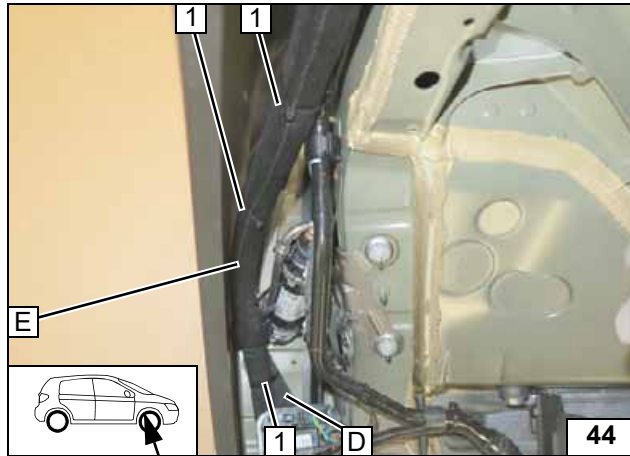

Route hoses **D** and **E** in wheel well to the front.

1 Cable tie [3x]



Routing hoses D and E in wheel well

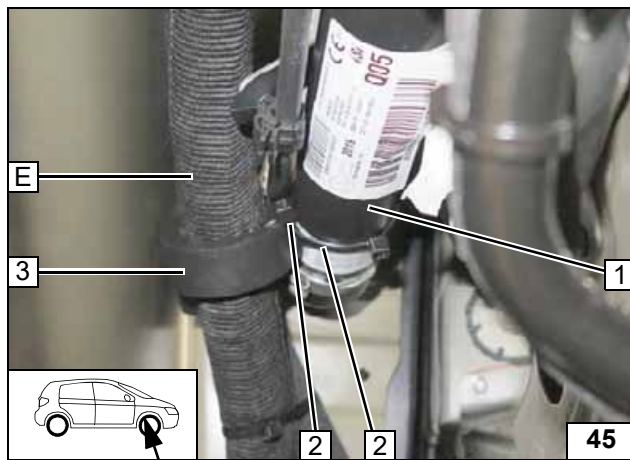

Align black (sw) rubber isolator **3** and fasten it with two interlaced cable ties **2** to original vehicle cartridge **1**.



Routing hoses D and E in wheel well

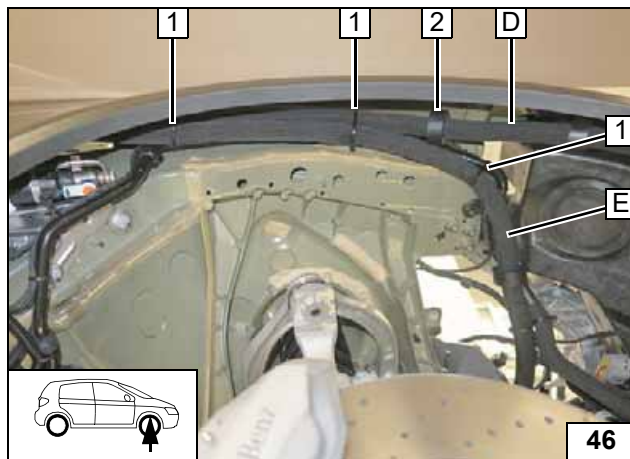

Route hoses **D** and **E** along original vehicle pipe and fasten with cable tie **1**. Align black (sw) rubber isolator **2** with original vehicle strut.



Routing hoses D and E in wheel well

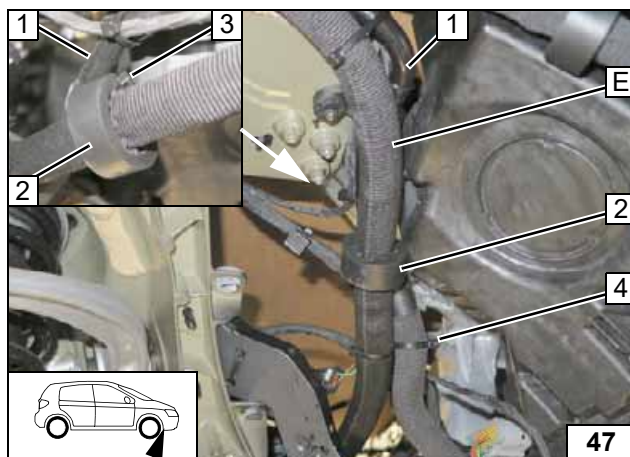

Align black (sw) rubber isolator **2** and fasten it with cable tie **3** to original vehicle pipe **1**. Fasten hose **E** with the two interlaced cable ties **4** to original vehicle hose.



Routing of hose E in wheel well

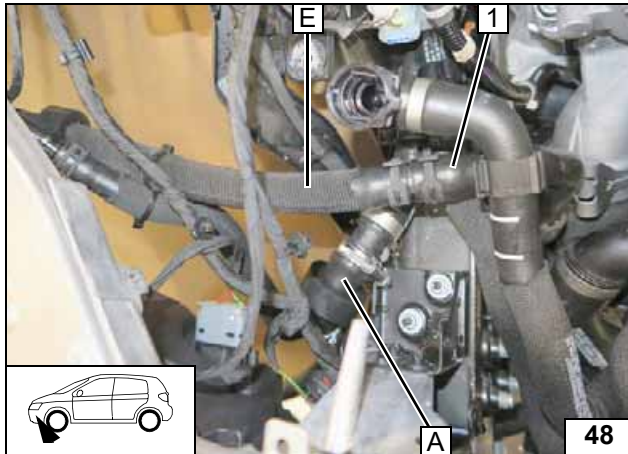

1 Engine inlet hose

Conne-
ction on en-
gine inlet

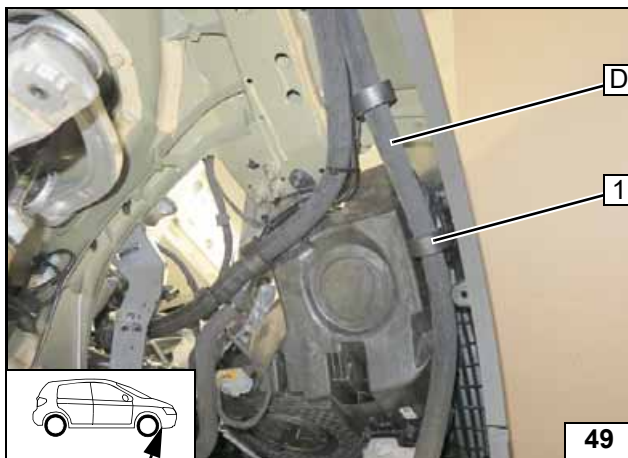

Route hose **D** to the coolant pump instal-
lation location.



1 Align black (sw) rubber isolator

Routing
hose **D**

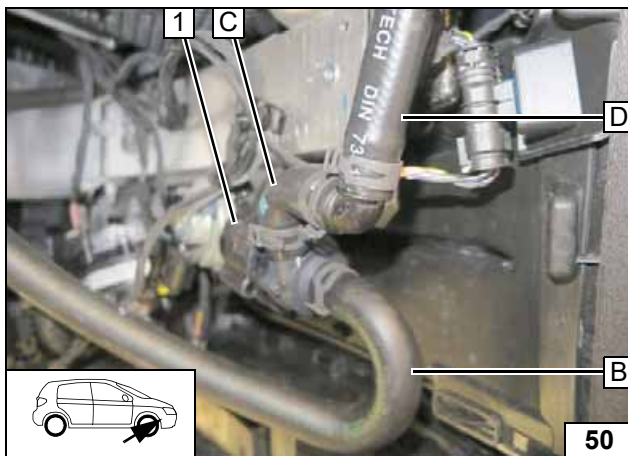

1 Coolant pump

Coolant
pump con-
nection

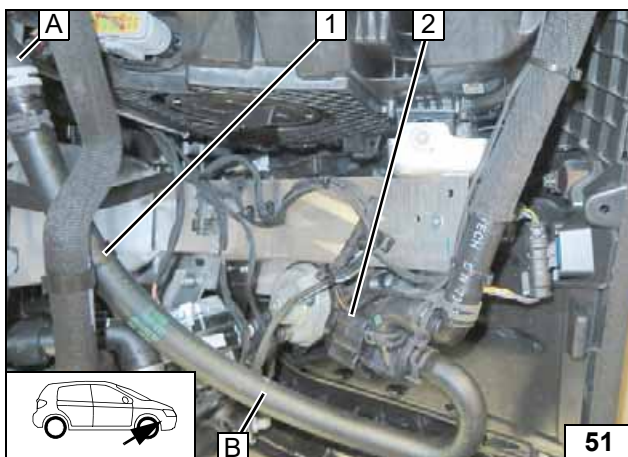

1 Hose bracket between hose **B** and
original vehicle hose
2 Coolant pump

Connecting
hose **B**

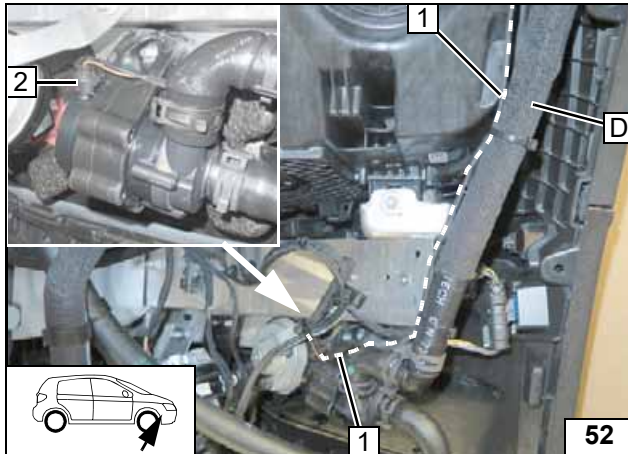
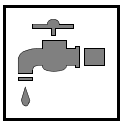

Route coolant pump wiring harness **1** along hose **D** and fasten at regular intervals with cable ties.

- 2** Connector of coolant pump wiring harness



Routing of coolant pump wiring harness

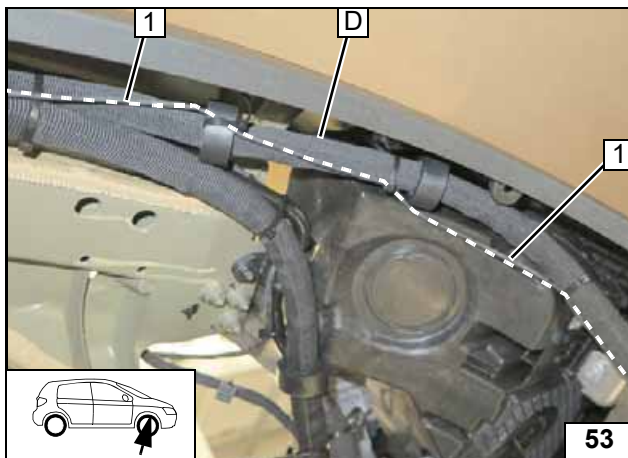

Route coolant pump wiring harness **1** along hose **D** and fasten at regular intervals with cable ties.



Routing of coolant pump wiring harness

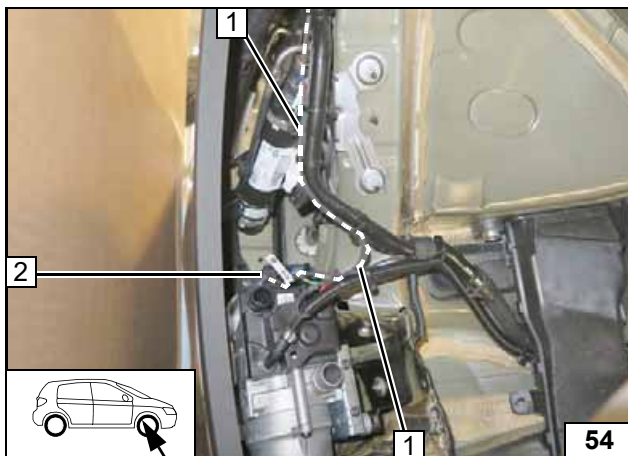

Route coolant pump wiring harness **1** along original vehicle pipe and fasten at regular intervals with cable ties.

- 2** Connector of coolant pump wiring harness, mounted



Routing of coolant pump wiring harness

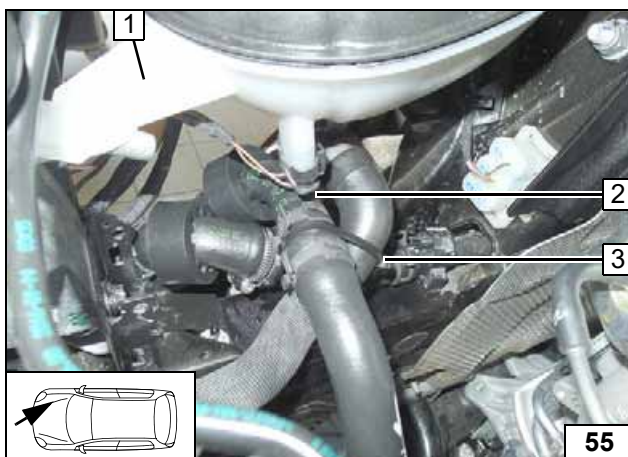

Install expansion tank **1**. Ensure sufficient distance from the coolant hoses at position **2**.

- 3** Attach hoses using cable tie



Distance check

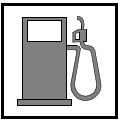

Fuel



Open the vehicle's fuel tank cap, ventilate the tank and then re-close the tank lock.

Catch any fuel running off in an appropriate container.



Route fuel line and fuel pump wiring harness so that they are protected against stone impact. Unless specified otherwise, always fasten using cable ties.

Provide rub protection for fuel line and wiring harness in areas where there are sharp edges.

The fuel line and wiring harness are routed to the fuel pump as shown in the wiring harness routing diagram.

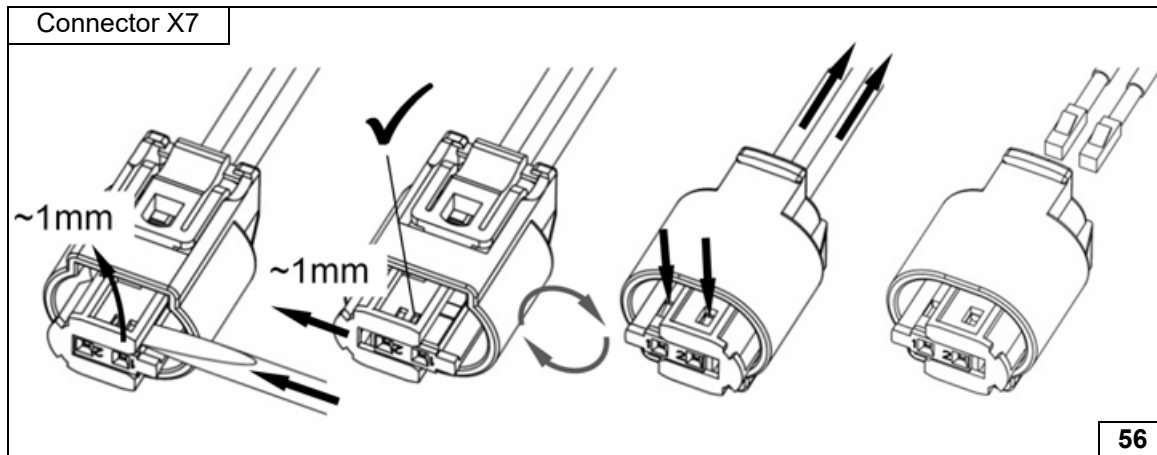

Dismantling fuel pump connector

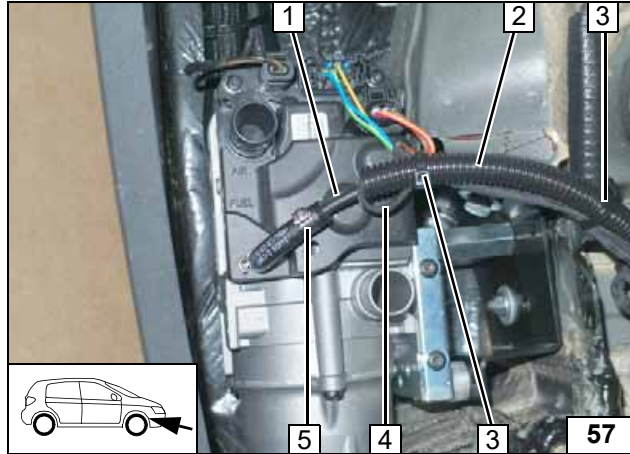

Cut 1,200mm from fuel line, this will be required for the connection of the FuelFix. Draw fuel line 1 and fuel pump wiring harness 4 into Ø10 corrugated tube 2.

- 3 Cable tie [2x]
- 5 Ø10 clamp

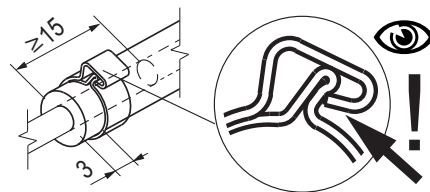

Connect-
ing heater

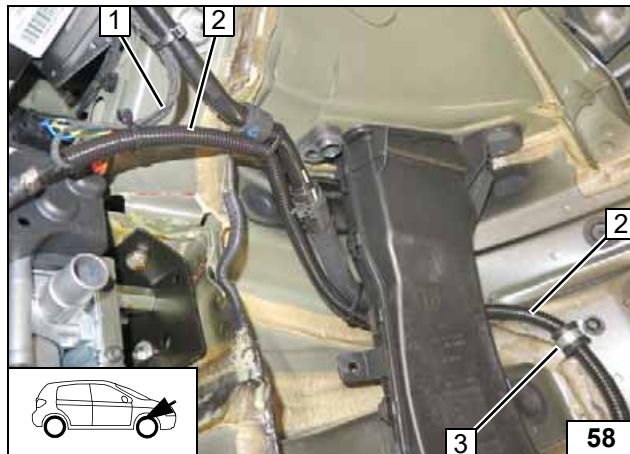

Fasten fuel line and fuel pump wiring harness in Ø10 corrugated tube 2 along original vehicle pipe with cable ties.

Fasten heater wiring harness 1 to corrugated tube 2 and further to original vehicle pipe with cable ties.

- 3 Ø15 rubber-coated p-clamp, plastic nut, original vehicle stud bolt

Routing
lines

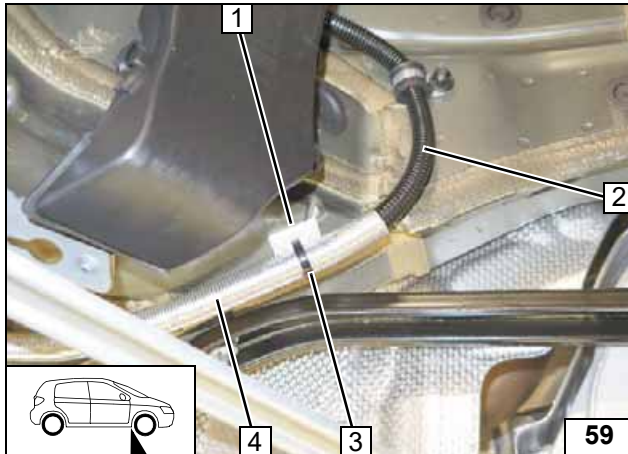

Degrease bonding surfaces at position 1.



Slide 300, Ø14.5 heat protection hose 4 onto Ø10 corrugated tube 2 and secure with cable tie 3.

- 1 Adhesive base

Routing lines

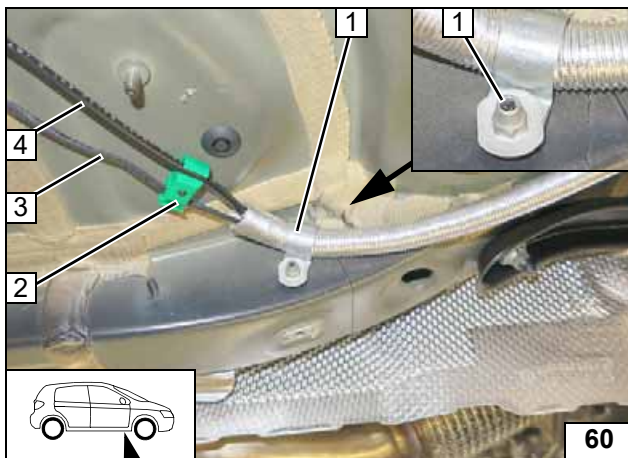

- 1 P-clamp, original vehicle stud bolt, plate nut
- 2 Line holder, original vehicle stud bolt
- 3 Fuel pump wiring harness
- 4 Fuel line

Routing lines

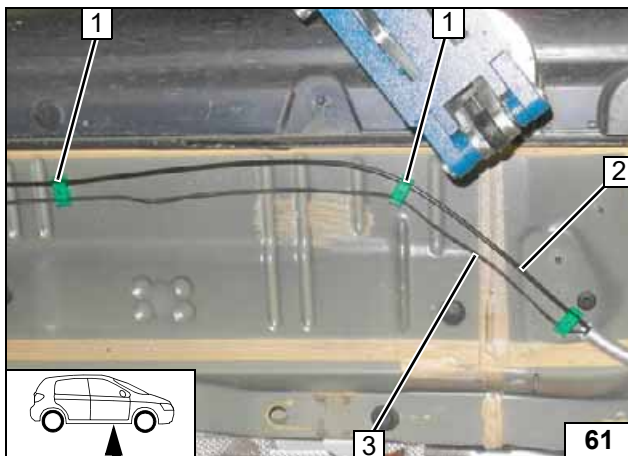

- 1 Line holder, original vehicle stud bolt [2x each]
- 2 Fuel line
- 3 Fuel pump wiring harness

Routing lines

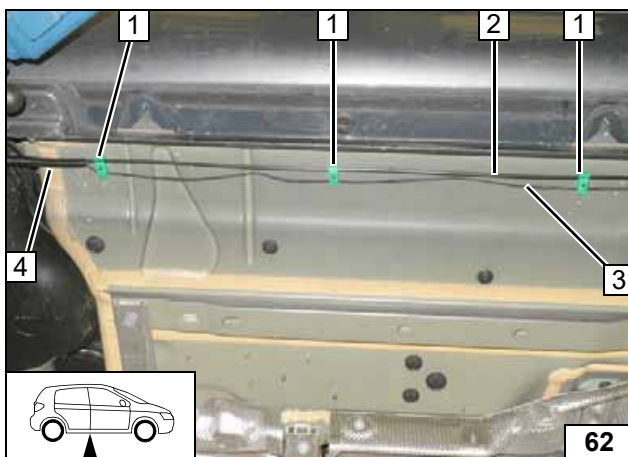

Route fuel line 2 and fuel pump wiring harness 3 to the fuel pump installation location, at the end draw into Ø10 corrugated tube 4.



- 1 Line holder, original vehicle stud bolt [3x each]
- 2 Fuel line
- 3 Fuel pump wiring harness

Routing lines

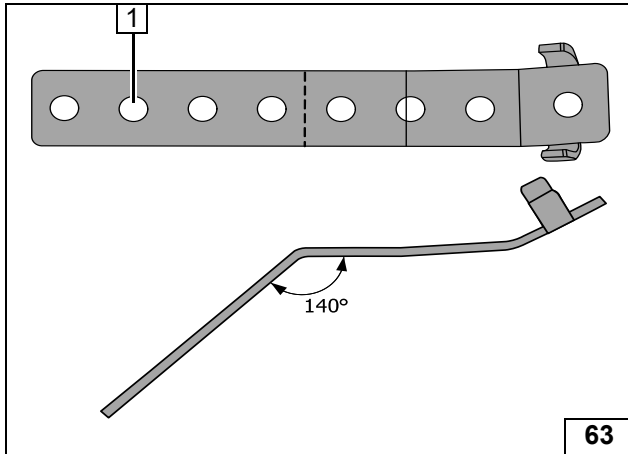
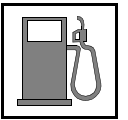

- 1 Screw point for the fuel pump installation (see next figures)

Angling down perforated bracket

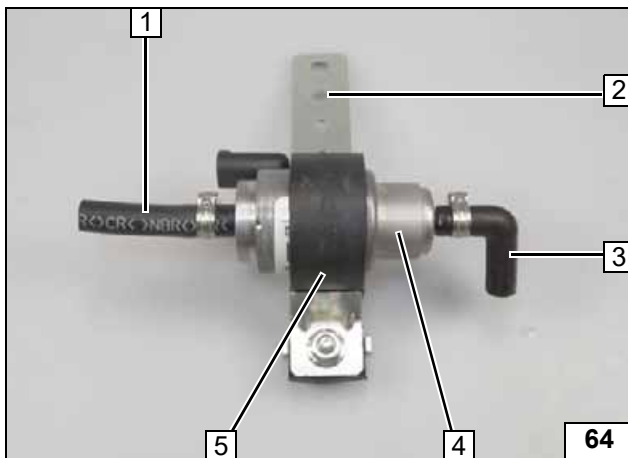

- 1 Hose section, Ø10 clamp
- 2 Screw point for the fuel pump installation
- 3 90° moulded hose (short side on fuel pump), Ø10 clamp
- 4 Fuel pump
- 5 Fuel pump mount

Premounting fuel pump

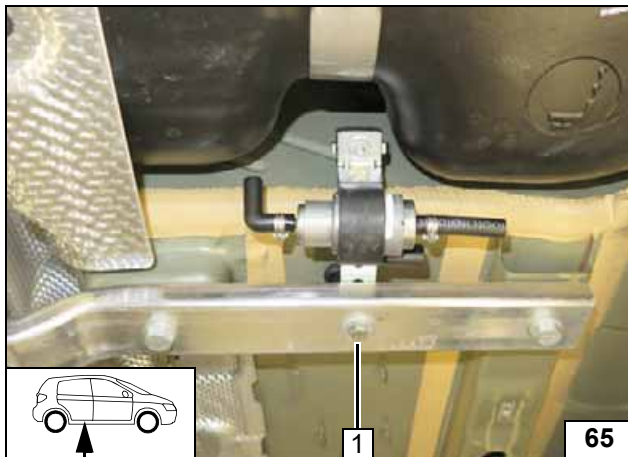
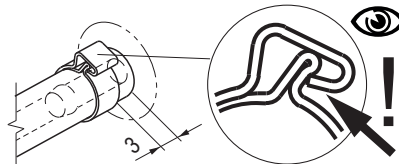

- 1 M6x30 bolt, large diameter washer, original vehicle hole, bracket, flanged nut

Mounting fuel pump

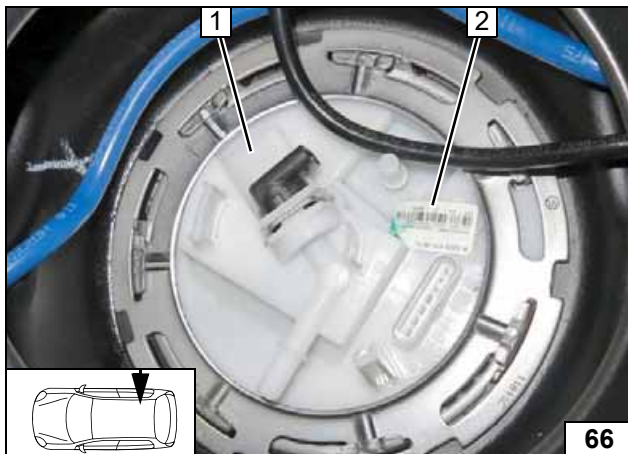

Installing FuelFix

- 1 Tank fitting
- 2 Sticker, moved

Moving sticker

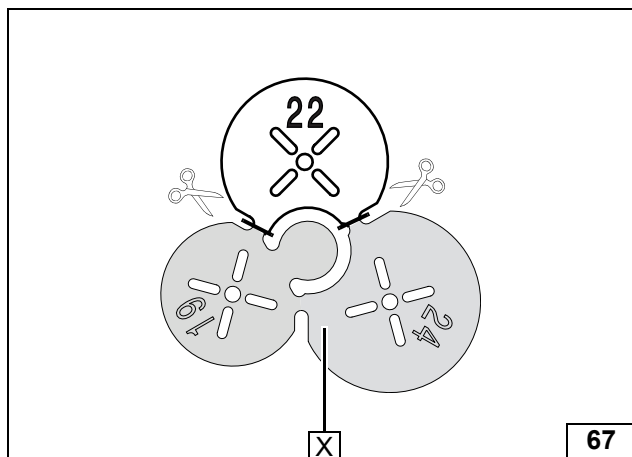

X =

Preparing drilling template

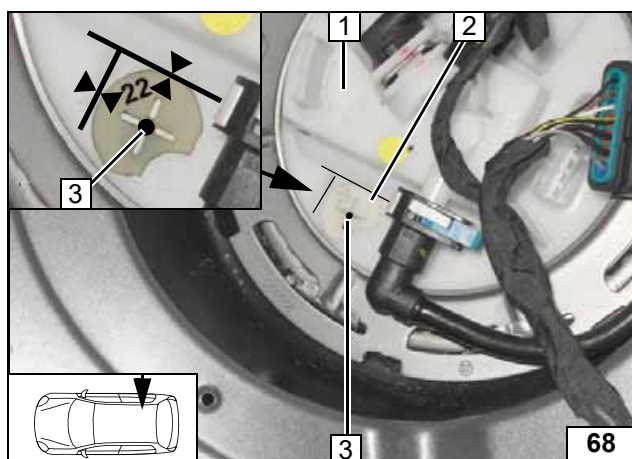

Work steps F1 and F2.

- 1 Tank fitting
- 2 Position Ø22 drilling template as shown
- 3 Copy hole pattern



Copying hole pattern

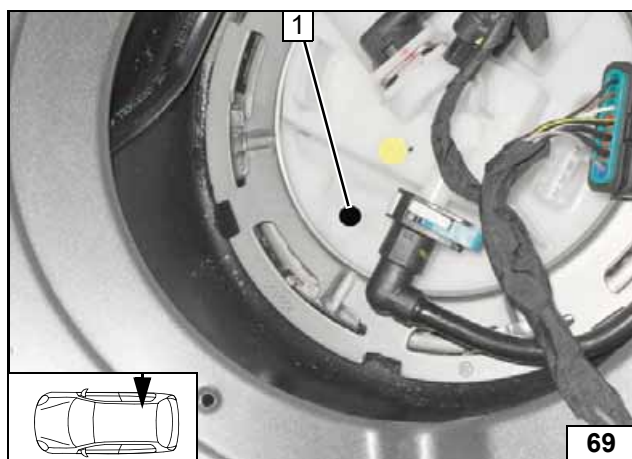

Work step F3.

- 1 Hole made with provided drill

Hole for FuelFix

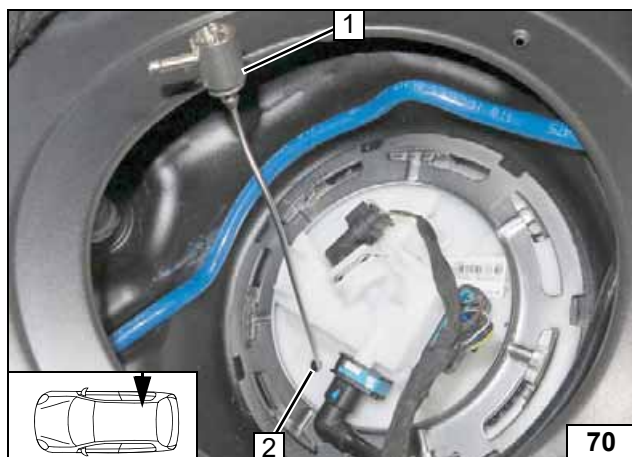

Work steps F4 and F5.

Bend FuelFix 1 according to template and cut to length. Insert into hole 2.



Inserting FuelFix



Inserting FuelFix

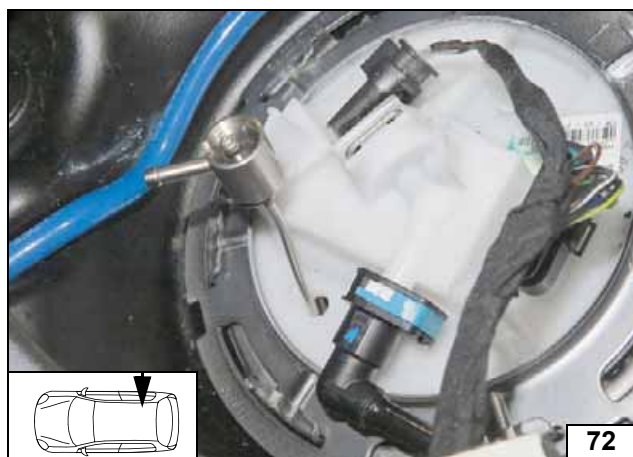

Inserting FuelFix



Inserting FuelFix

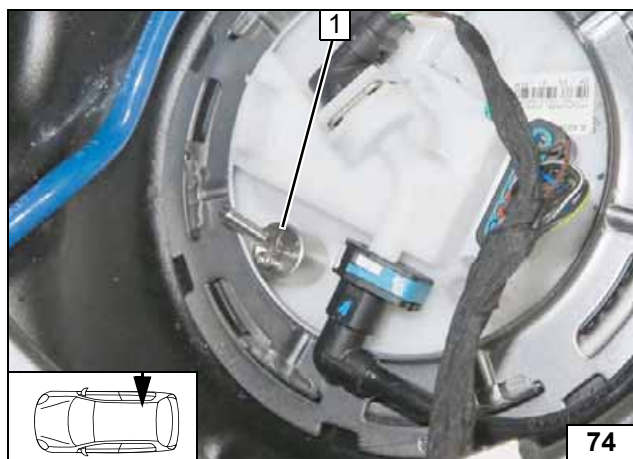

Work steps F5.3 and F5.4.

Align FuelFix 1 as shown.



Aligning FuelFix

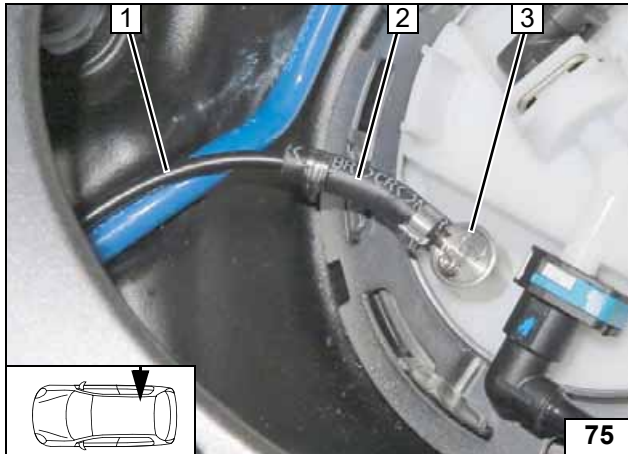
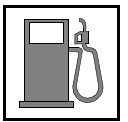

Work step F6.

- 1 Fuel line
- 2 Hose section, Ø10 clamp [2x]
- 3 FuelFix

Connect-
ing fuel line

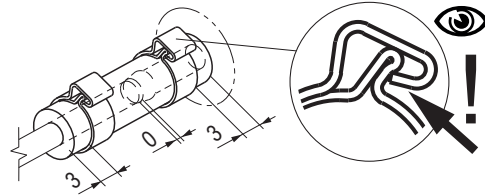

Work step F7.

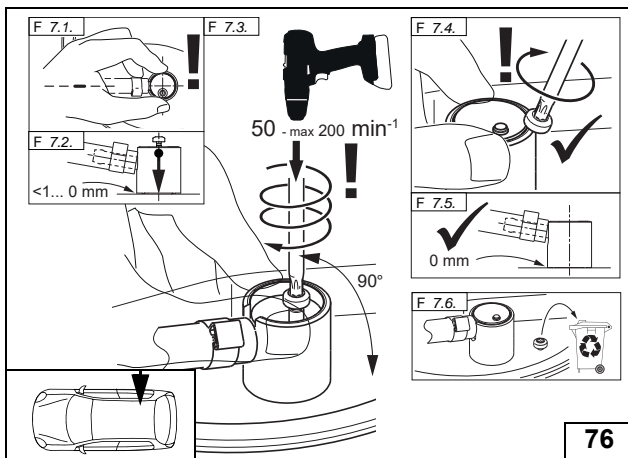

Installing
FuelFix

Work step F8.



Checking
firm seating
of FuelFix

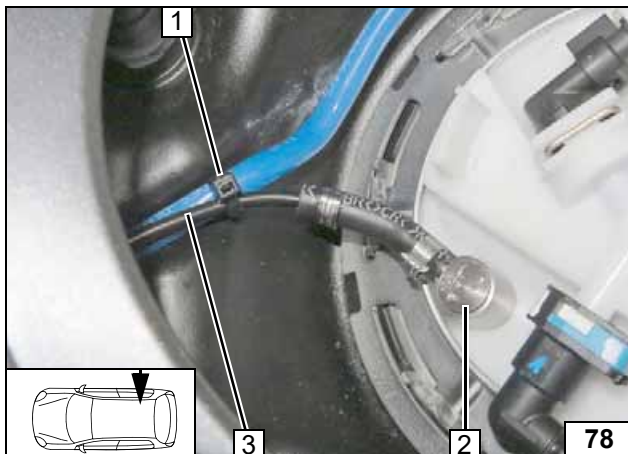

- 1 Cable tie as tension relief
- 2 FuelFix installed
- 3 Fuel line of FuelFix

Securing
fuel line

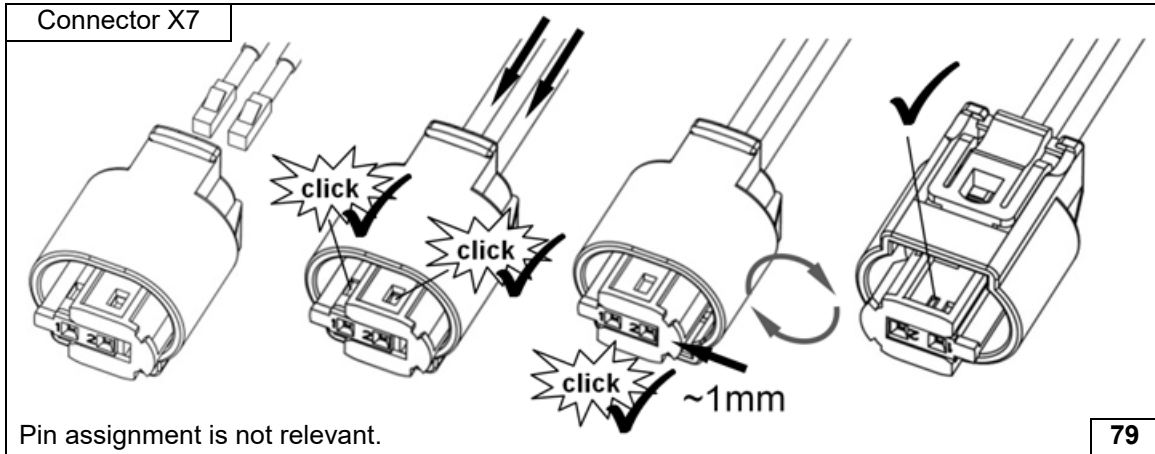
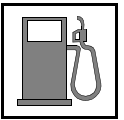

Pin assignment is not relevant.

79

Completing fuel pump connector

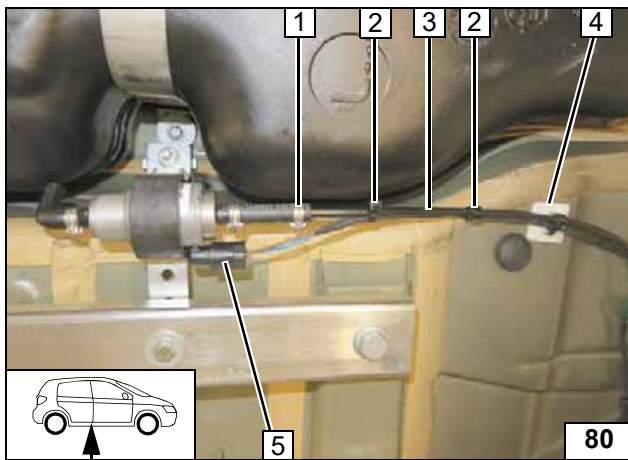

80

Degrease bonding surfaces at position 4.

- 1 Ø10 clamp
- 2 Cable tie
- 3 Heater fuel line
- 4 Adhesive base, cable tie
- 5 Fuel pump wiring harness, connector X7 mounted



Fuel pump connection

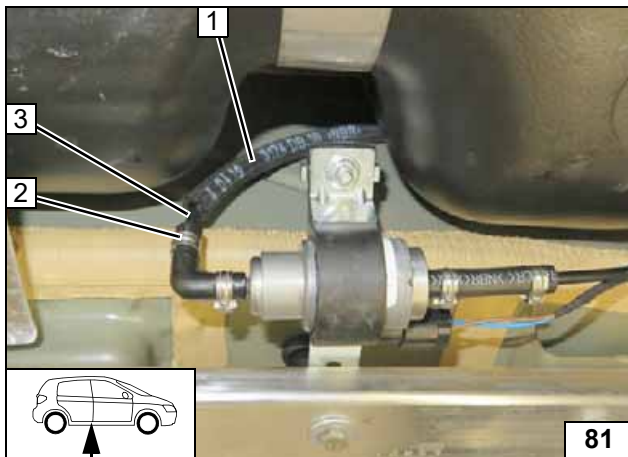
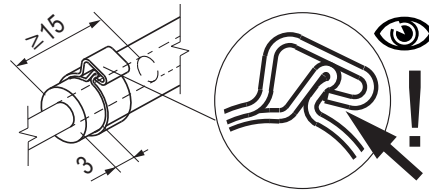

81

Ensure sufficient distance from neighbouring components, correct if necessary. Slide 6x11 fabric protective hose 1 onto fuel line of FuelFix 3.

- 2 Ø10 clamp



Fuel pump connection

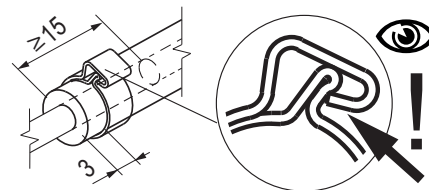

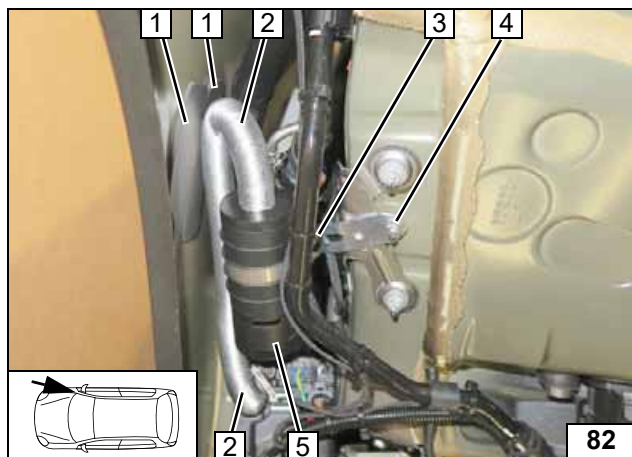
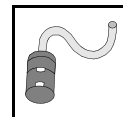

Combustion air

Ensure sufficient distance between combustion air intake silencer and original vehicle pipe, correct if necessary.

- 1 Glue insulation protection strips [2x]
- 2 Combustion air pipe
- 3 M5x16 bolt, perforated bracket, Ø51 clamp, flanged nut
- 4 Original vehicle stud bolt, perforated bracket, M6 flanged nut
- 5 Combustion air intake silencer



Mounting combustion air intake silencer and combustion air pipe

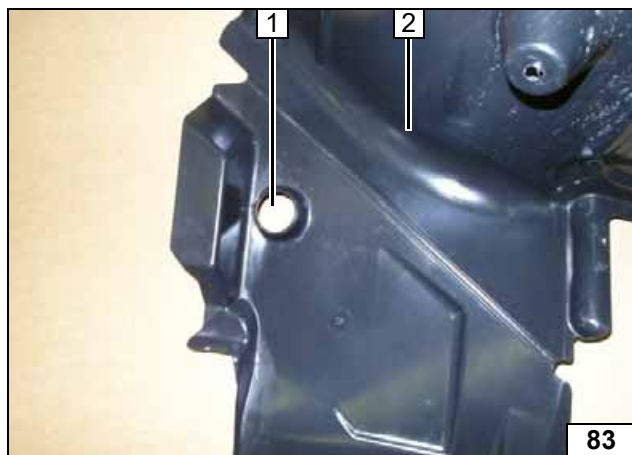

Final work

Enlarge existing opening at position **1** to Ø60.

2 Rear section of the wheel well trim



Hole for exhaust pipe a2

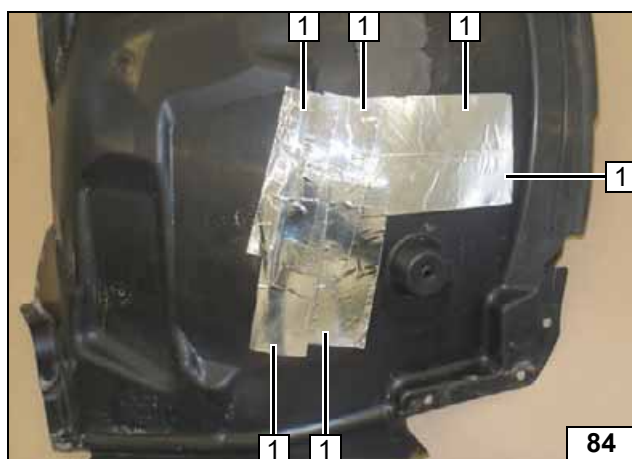

Cut heat protection strip **1** in half and stick on as shown.



Sticking on heat protection strip

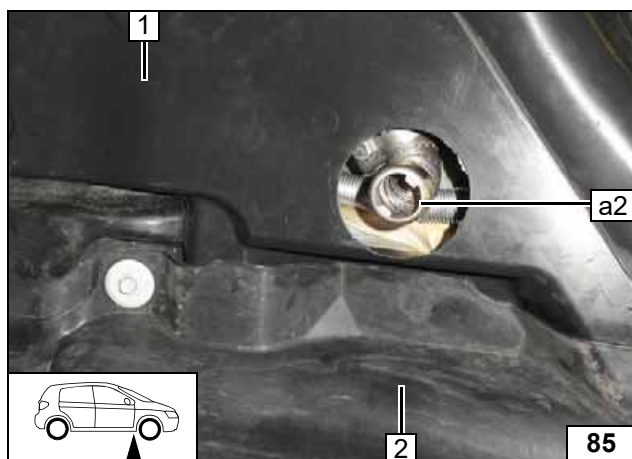

Ensure sufficient distance from neighbouring components, correct if necessary. Install wheel well trim **1**. Align exhaust pipe **a2** with the centre of the hole and flush with wheel well trim **1**.



2 Underride protection

Installing underride protection



Reassemble the components in reverse order. Check all hoses, clamps and all electrical connections for firm seating. Insulate and tie back loose lines.

Only use manufacturer-approved coolant. Spray the heater components with anti-corrosion wax (Tectyl 100K).

- **Connect the battery.**
- **Fill and bleed the coolant circuit according to the vehicle manufacturer's instructions.**
- **Teach Telestart transmitter**
- **For initial start-up and function check, please see installation instructions.**
- **For the settings of the A/C control panel see the installation documentation in the additional 'Webasto Comfort' A/C control kit section 'Final Work'**
- **Place the 'Switch off parking heater before refuelling' caution label near the filler point.**





FuelFix template

Top view

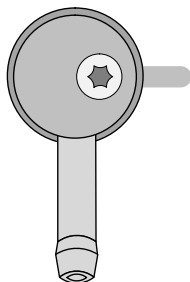

100mm



Scale 1:1

Compare size of printout with dimension lines.
Maximum permitted tolerance 2%.

Set the printer settings to 'no margin' or 'minimise margins' and 100% of the normal size.

100mm

0