

K Installation documentation

for water heater Thermo Top Evo

'Island' coolant circuit without engine preheating

BMW 1 Series F40

Left-hand drive vehicle

Manufacturer	Model	Type	Model year	EG-BE-No. / ABE
BMW	1 Series F40	F1H	from 2020	e1* 2007/46* 2018*...

Motorisation	Fuel	Emission standard	Transmission type	Output [kW]	Displacement [cm ³]	Engine code
118i	Petrol	Euro 6;WLTP;DG...	DKG	103	1499	B38A15

Validity	Equipment variants	Model
		1 Series
Verified equipment variants	2 zone automatic air-conditioning	x
	LED main headlights	x
	LED front fog lights	x
	M Aerodynamics package	x
	Active pedestrian protection	x

Total installation time	Note
9.0 hours	

Contents

1	List of abbreviations	3
2	Installation notes	4
2.1	Information on Validity	4
2.2	Components used	4
2.3	Notes on installation, in coordination with the end customer	4
2.4	Information on Total Installation Time	4
3	About this document	5
3.1	Purpose of the document	5
3.2	Warranty and liability	5
3.3	Safety	5
3.4	Using this document	6
4	Technical Information	7
5	Preparations	8
5.1	Vehicle preparation	8
5.2	Heater preparation	8
6	Installation overview	9
7	Electrical system of engine compartment	10
8	Mechanical system, part 1	13
8.1	Preparing installation location	13
8.2	Premounting heater	16
8.3	Heater mounting	17
9	Fuel	18
9.1	Routing fuel line	18
9.2	Installing FuelFix	23
10	Exhaust part 1	28
11	Coolant	31
11.1	Preliminary Work	31
11.2	Hose routing diagram	35
11.3	Coolant circuit installation	36
12	Combustion air	42
13	Exhaust part 2	43
14	Electrical system of passenger compartment	48
14.1	Air-conditioning control	48
15	Final Work	49
16	FuelFix template	51

1 List of abbreviations

AAC	Automatic air-conditioning
DP	Fuel pump
EFIX	Exhaust end fastener
FF	FuelFix (tank extracting device)
Fig.	Figure
HG	Heater
SH2	Engine compartment fuse holder for F1/F2
UP	Coolant pump
Veh.	Vehicle
X10	Female plug for control element

2 Installation notes

2.1 Information on Validity

This installation documentation applies to vehicles listed on page 1, assuming technical modifications to the vehicle do not affect installation, any liability claims excluded. Depending on the vehicle version and equipment, modifications may be necessary during installation with respect to this installation documentation. Vehicle and engine types, equipment variants and other specifications not listed in this installation documentation have not been tested. However, installation according to this installation documentation may be possible.

2.2 Components used

Designation	Order number
Basic delivery scope of Thermo Top Evo	In accordance with price list
Installation kit for BMW X1 (F48) 2019 / X2 (F39) 2018 / 1 Series (F40) P 2020 / 2 Series (F45) 2019 petrol	1326525D
Additional 'Webasto Comfort' A/C control kit for BMW 1 Series (F40) MY 2020, 3 Series (G20/21), 5 Series (G30/31), X3/X4 (G01)	1326680_
In case of Telestart, control element, as well as indicator lamp in consultation with end customer	In accordance with price list

2.3 Notes on installation, in coordination with the end customer

- ▶ Arrange for the vehicle to be delivered with the tank only about ¼ full.
- ▶ The installation location of the following elements should be chosen in coordination with the end customer:
 - the push button in case of the Telestart and/or ThermoCall and/or ThermoConnect options
 - the MultiControl CAR option

We recommend:

- installing a Thermo Top Evo 4. The heater is integrated into the coolant circuit as an 'island' and heats up the vehicle passenger compartment. There is no engine pre-heating.

2.4 Information on Total Installation Time

The total installation time includes the time needed for mounting and demounting the vehicle-specific components, the heater specific installation time and all other times required for the system integration and initial start-up of the heater.

The total installation time may vary for vehicle equipment other than provided.

3 About this document

3.1 Purpose of the document

This installation documentation is part of the product and contains all the information required to ensure professional vehicle specific installation of the:

Thermo Top Evo heater

3.2 Warranty and liability

Webasto shall assume no liability for defects, damage and injuries resulting from a failure to observe the installation, repair and operating instructions of the information contained in them.

This liability exclusion particularly applies to improper installations and repairs by untrained persons or in the case of a failure to use genuine spare parts.

The liability due to culpable disregard to life, limb or health and due to damage or injuries caused by a wilful or reckless breach of duty remain unaffected, as does the obligatory product liability.

Installation should be carried out according to the general, standard rules of technology. Unless specified otherwise, fasten hoses, lines and wiring harnesses to original vehicle lines and wiring harnesses using cable ties. Insulate loose wire ends and tie back. Connectors on electronic components must audibly snap into place during assembly.

Spray unfinished body areas, e.g. drilled holes, with anti-corrosion wax (Tectyl 100K).

Observe the instructions and guidelines of the respective vehicle manufacturer for demounting and mounting vehicle specific components.

The initial start-up is to be executed with the Webasto Thermo Test Diagnosis.

When installing a programmable control module (e.g. a PWM Gateway), the corresponding settings must be checked or adjusted.

3.2.1 Statutory regulations governing installation

The Thermo Top Evo heater has been type-tested and approved in accordance with ECE-R 10 (EMC) and ECE-R 122 (heater). The regulations of these guidelines are binding in the scope of the Directive 70/156/EEC and/or 2007/46/EC (for new vehicle models from 29/04/2009) and should also be observed in countries in which there are no special regulations.

The heater is licensed in accordance with paragraph 19, section 3, No. 2b of the StVZO (German Road Traffic Licensing Authority).

3.3 Safety

Qualifications of installation personnel

The installation personnel must have the following qualifications:

- Successful completion of Webasto training
- Corresponding qualification for working on technical systems

Regulations and legal requirements

The regulations from the heater's general installation and operating instructions must be observed.

3.3.1 Safety information on installation

Danger posed by live parts

- ▶ Prior to installation, disconnect the vehicle from the voltage supply.
- ▶ Make sure the electrical system is earthed correctly.
- ▶ Always comply with legal requirements.
- ▶ Observe data on type label.

Danger of fire and leaking toxic gases due to improper installation

- ▶ Vehicle parts in the vicinity of the heater must be protected against excessive heating by the following measures:
 - ⇒ Maintain minimum safety distances.
 - ⇒ Ensure adequate ventilation.
 - ⇒ Use fire-resistant materials or heat shields.

Danger due to sharp edges

- Lacerations
 - Short circuit due to electrical wire damage
- ▶ Fit protectors on sharp edges.

3.4 Using this document

Before installing and operating the heater, read this installation documentation, the installation instructions of the heater, the operating instructions and supplementary sheets provided.

3.4.1 Explanatory Notes on the Document

There is an identification mark near the respective work step to allow you to quickly allocate the other applicable documents to the Webasto components to be installed:

Generally valid Webasto documentation	
Vehicle-specific installation documentation	
Vehicle-specific installation documentation of the cold start kit	
Webasto Comfort A/C control	
Webasto Standard A/C control	
Tank extracting device (e.g. FuelFix)	
Exhaust end fastener (EFIX)	
Combustion air intake silencer	
Spacer bracket (ASH)	

3.4.2 Use of symbols



DANGER

Type and source of the risk

Consequences: Failure to follow the instructions can result in death

► Actions to protect yourself against risks.



WARNING

Type and source of the risk

Consequences: Failure to follow the instructions can lead to serious or even fatal injuries

► Actions to protect yourself against risks.



CAUTION

Type and source of the risk

Consequences: Failure to follow the instructions can lead to minor injuries

► Actions to protect yourself against risks.



Type and source of the risk

Consequences: Failure to follow the instructions can lead to material damage

► Actions to protect yourself against risks.



Reference to the vehicle manufacturer's specific documents.



Note on a special technical feature

3.4.3 Work step identification marks

The ongoing work step is indicated on the outside top corner of the page:

Mechanical system	Electrical system	High-voltage	Coolant
Combustion air	Fuel	Exhaust	Software

3.4.4 Orientation aid

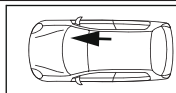

The arrow indicates the position on the vehicle and the viewing angle

3.4.5 Use of highlighting

Highlight	Explanation
✓	Action
►	Necessary action
⇒	Result of an action
1 / 12 / a1	Position numbers for the image descriptions
① / ⑫ / Ⓐ	Position numbers for the image descriptions for electrical wires and components as well as coolant hose sections

4 Technical Information

Dimension specifications

- All dimensions specified in mm
- Perforated brackets and mounting angles are shown to scale
- Observe data regarding scale on the templates

Tightening torque specifications

- Tightening torque values of 5x13 heater bolts and 5x11 heater stud bolts = 8Nm
- Tightening torque values of 5x15 retaining plate of water connection piece bolts = 7Nm
- 5x12 bolt tightening torque of 2-part heater bracket = 6Nm
- Tighten other bolt connections in accordance with manufacturer's instructions or in accordance with state-of-the-art-technology

Temperature specification for heat shrink plastic tubings

- Fabric heat shrink tubing: shrink temperature max. 230°C
- Standard heat shrink plastic tubing: shrink temperature max. 300°C

Necessary special tools

- Hose clamp pliers for auto-tightening hose clamps
- Hose clamp pliers for Clic hose clamps of type W
- Hose clamping pliers
- Hose cutter
- Automatic wire stripper 0.2 - 6 mm²
- Crimping pliers for cable lugs 0.5 – 10 mm²
- Crimping pliers for male connector 0.14 – 6 mm²
- Crimping pliers for connector 0.25 – 6 mm²
- Torque wrench for 2.0 - 10 Nm
- Deep-hole marker
- Metric thread-setter kit
- Webasto Thermo Test Diagnosis with current software

5 Preparations

5.1 Vehicle preparation



Further information can be found in the vehicle manufacturer's technical documentation.

Vehicle area	Components to be removed	Other applicable documents
General	<ul style="list-style-type: none"> ▶ Open the fuel tank cap ▶ Ventilate the fuel tank ▶ Close the fuel tank cap again ▶ Depressurise the cooling system 	
Engine compartment and body	<ul style="list-style-type: none"> ▶ Disconnect the battery ▶ Air filter complete with intake hose ▶ Water drain chamber cover ▶ Lower engine cover ▶ Front wheel on the driver's and front passenger's side ▶ Wheel well trim on the driver's side ▶ Detach the front part of the wheel well trim on the front passenger's side ▶ Underride protection on the front passenger's side ▶ Bumper trim ▶ Headlights on the driver's side 	
Passenger compartment	<ul style="list-style-type: none"> ▶ Complete rear seat ▶ Open the tank fitting service lid on the front passenger's side 	

5.2 Heater preparation

Engine compartment	<ul style="list-style-type: none"> ▶ Remove years that do not apply from the type and duplicate label ▶ Attach the duplicate label (type label) in the appropriate place in the engine compartment 	
--------------------	--	--

6 Installation overview

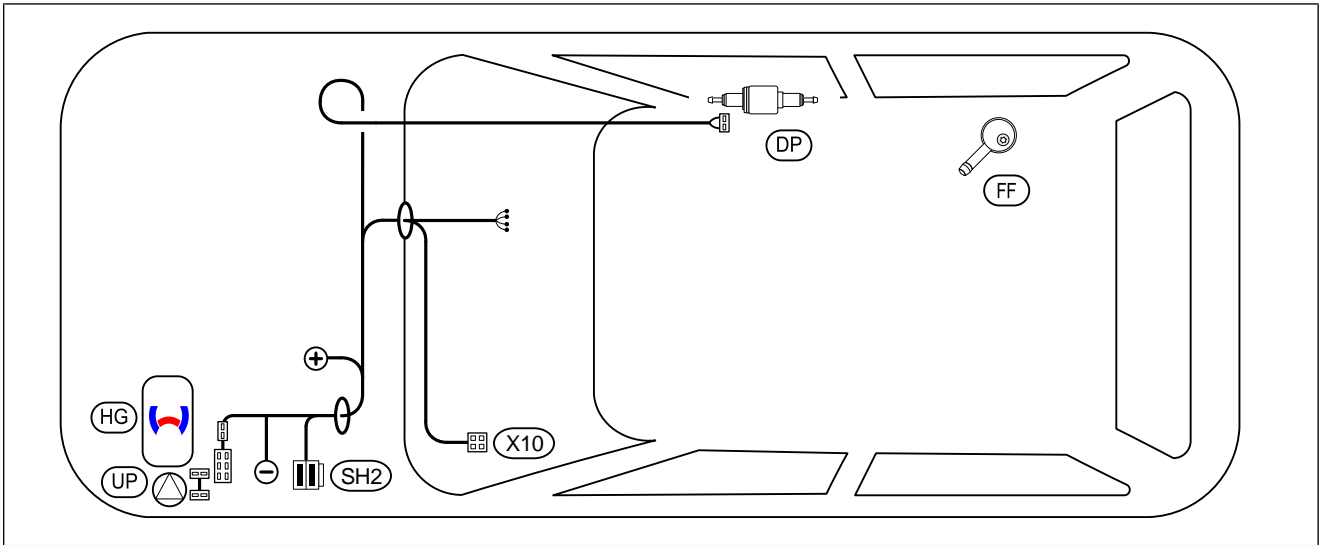
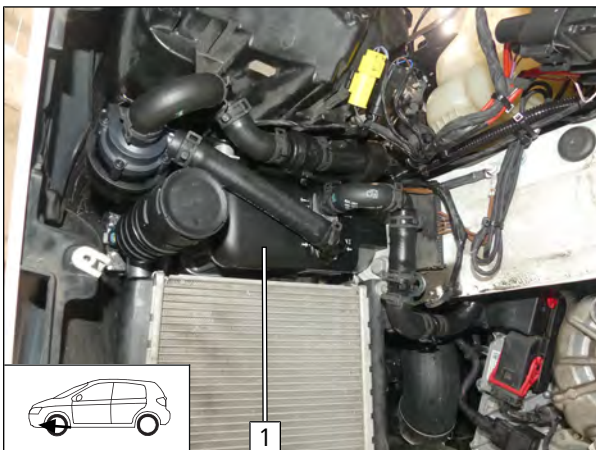

Fig. 1

Legend to installation overview

Abbreviation	Component
DP	Fuel pump
HG	Heater
FF	FuelFix
SH2	Engine compartment fuse holder
UP	Coolant pump
X10	Female plug for control element

Heater installation location



1 Heater

Fig. 2



7 Electrical system of engine compartment

Pre-assembling engine compartment fuses

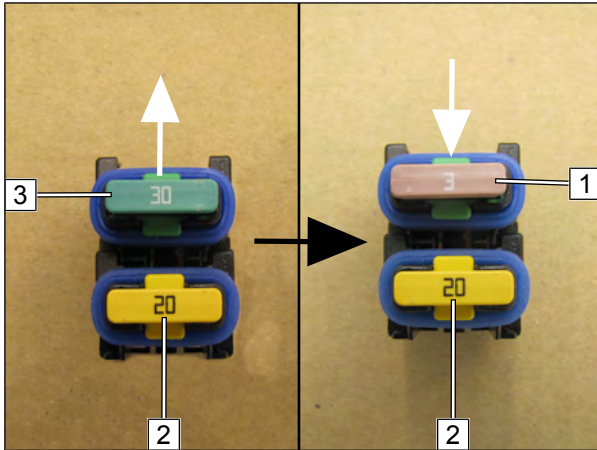

Fig. 3

► Replace 30A passenger compartment main fuse F2 **3** with 3A fuse **1**.

2 Fuse F1: 20A

Drilling hole

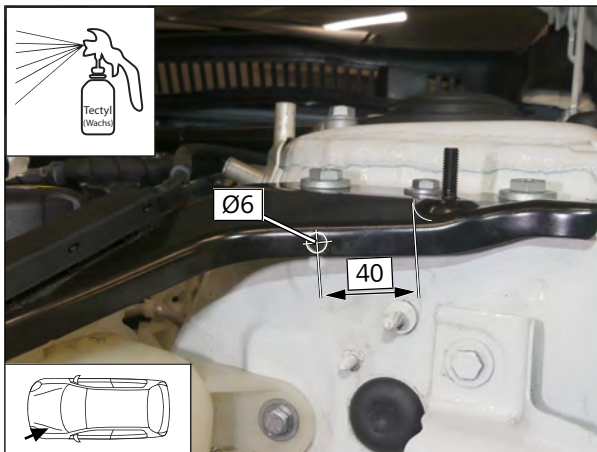

Fig. 4

Mounting retaining plate, fuse holder SH2

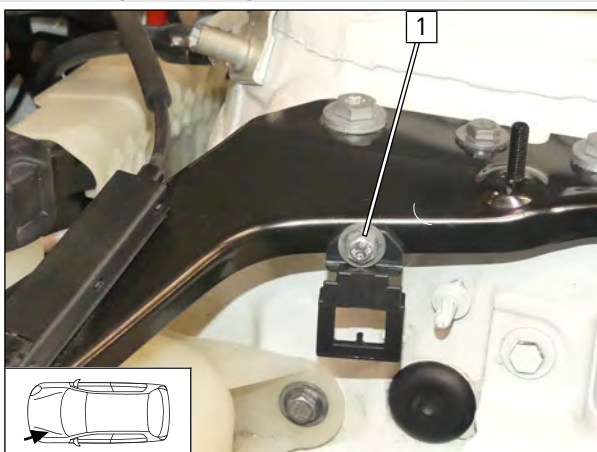

Fig. 5

1 M5x16 bolt, large diameter washer, retaining plate SH2, drilled hole, large diameter washer, nut



Mounting fuse holder SH2

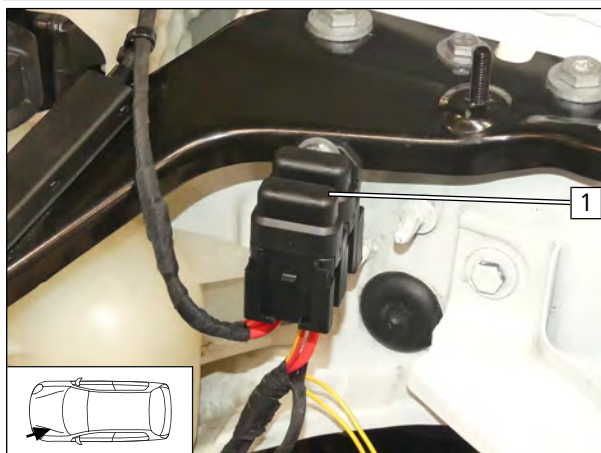

Fig. 6

- 1 Fuse holder SH2 with F1/F2

Routing and fastening wiring harness

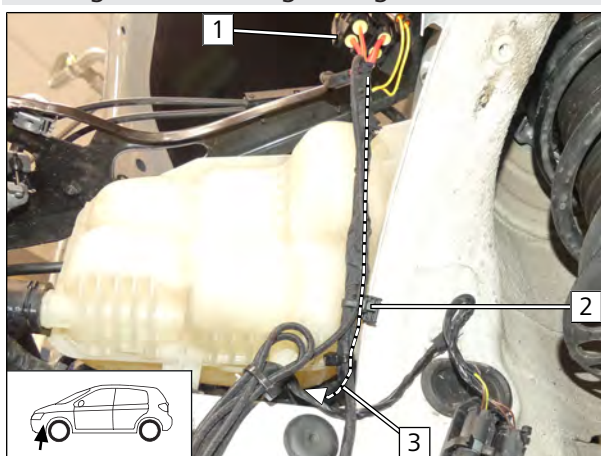

Fig. 7

- Route passenger compartment and control element wiring harnesses 3 under the expansion tank.

- 1 SH2
- 2 Edge clip cable tie

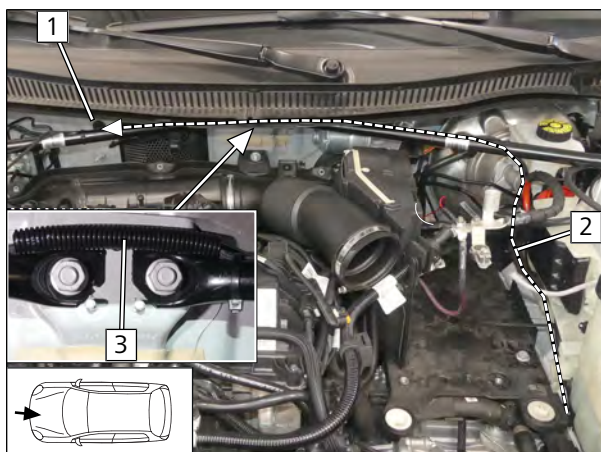

Fig. 8

- Route passenger compartment and control element wiring harnesses 2 along the original vehicle wiring harness to the strut brace.

- 1 Passenger compartment pass through
- 3 100 long unslit corrugated tube



Passenger compartment wiring harness pass through

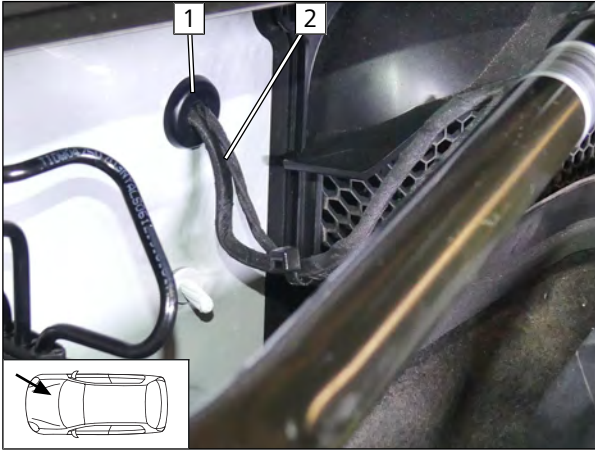

Fig. 9



To prevent water seeping into the passenger compartment, the wiring harness must be routed upwards to the protective rubber plug and this plug must then be sealed with a suitable sealing compound.

- ▶ Route passenger compartment and control element wiring harnesses **2** through protective rubber plug **1** into the passenger compartment.

Mounting positive wire

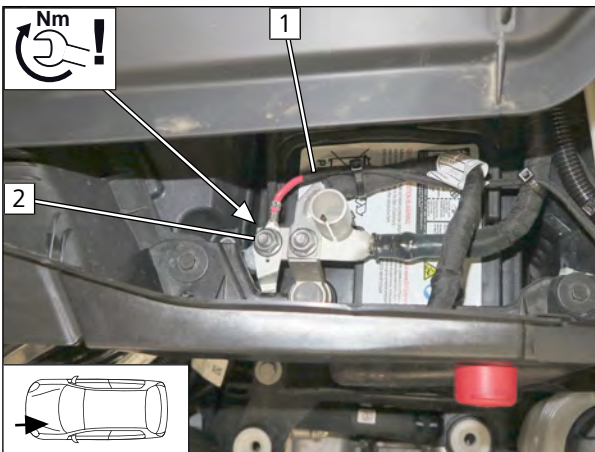

Fig. 10



DANGER

Observe tightening torque



The Fig. shows the installation situation. The battery is connected during the final work phase.

- 1** Positive wire
- 2** Original vehicle positive support point

Mounting earth wire

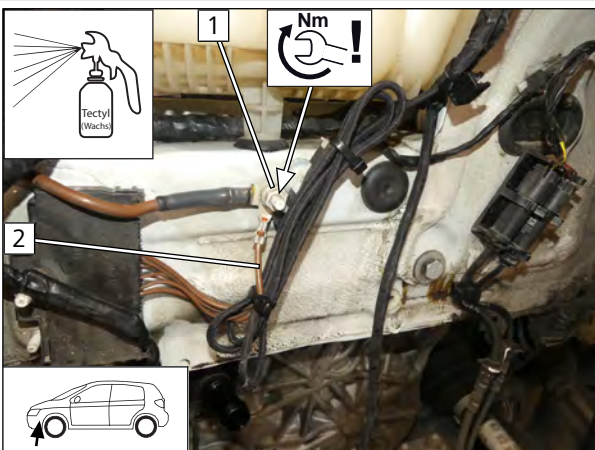

Fig. 11



DANGER

Observe tightening torque

- 1** Original vehicle earth point
- 2** Earth wire



8 Mechanical system, part 1

8.1 Preparing installation location

Removing horn

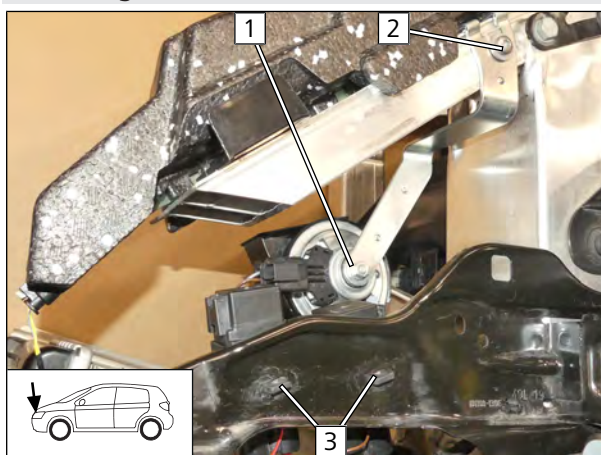

Fig. 12

- ▶ Remove original vehicle nut at position **1**, horn and nut will be reused.
- ▶ Remove original vehicle bolt at position **2**, discard bracket and bolt.
- ▶ Detach relay at pos. **3**.

Preparing perforated bracket

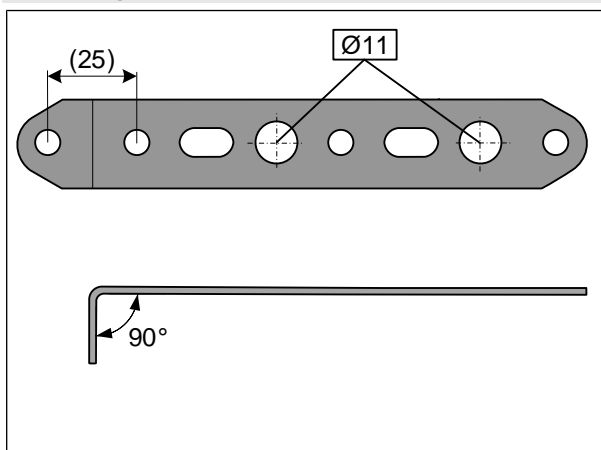

Fig. 13

Installing perforated bracket

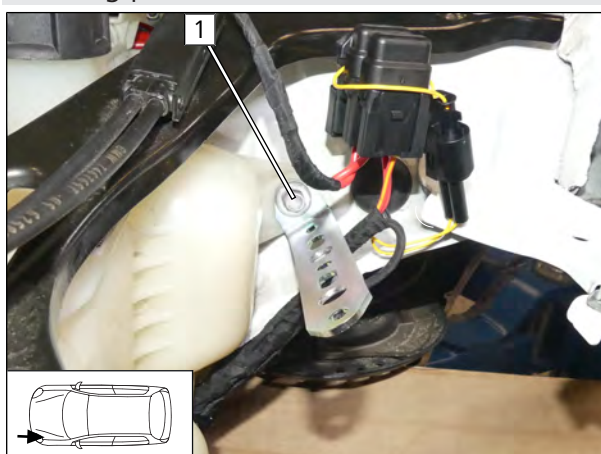

Fig. 14

- 1** Original vehicle bolt, perforated bracket, original vehicle hole in expansion tank, original vehicle threaded hole



Mounting horn

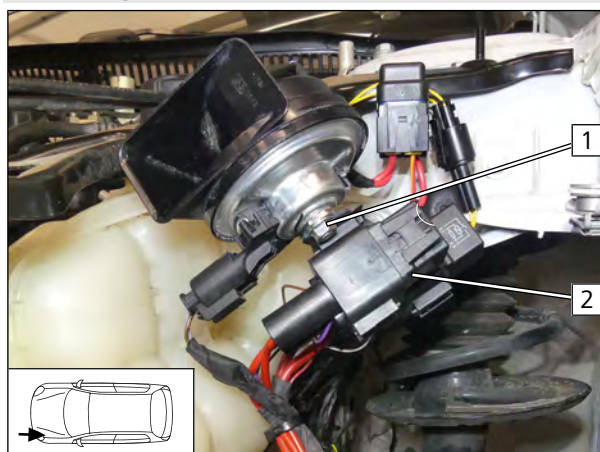

Fig. 15

- 1 Horn, perforated bracket, original vehicle nut
- 2 Click relay into Ø11 hole

Routing and fastening heater wiring harness

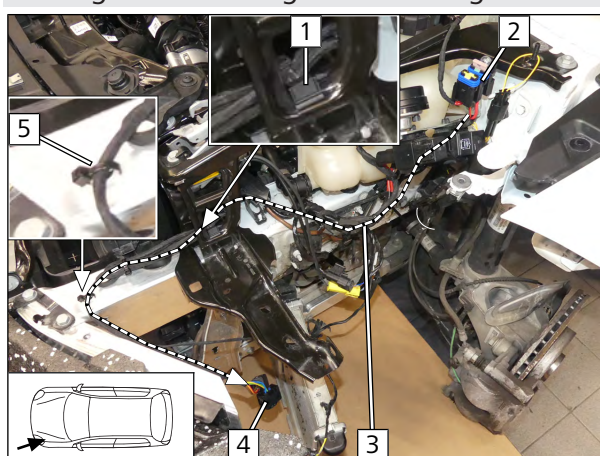

Fig. 16

- 1 Edge clip cable tie
- 2 SH2
- 3 Heater wiring harness
- 4 Heater wiring harness connector
- 5 Fix with glue pad on carrier and cable tie

Shortening heater bracket

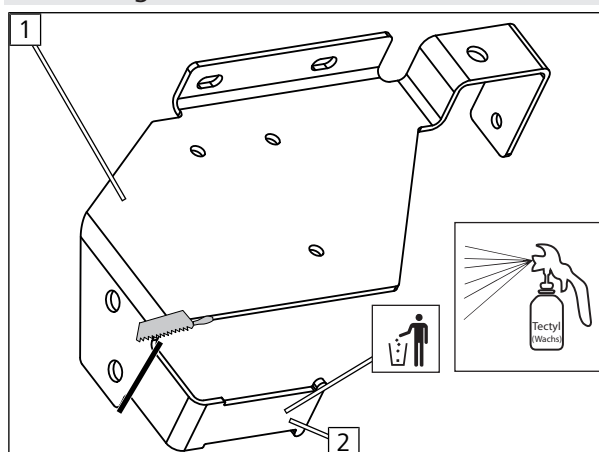
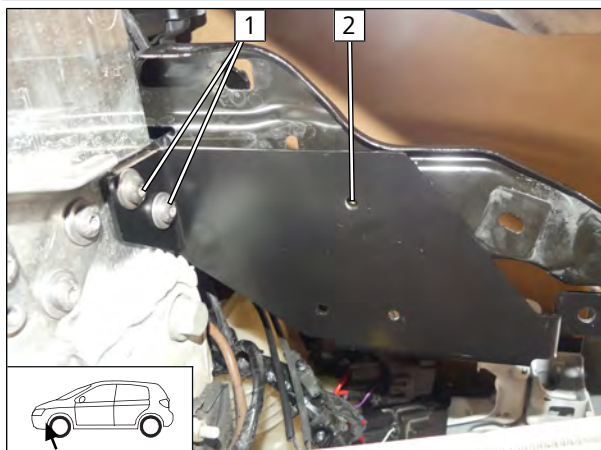

Fig. 17

► Cut off tab 2 of heater bracket 1 as shown.



Copying hole pattern



- ▶ Mount HG bracket at pos. **1** loosely and copy hole pattern **2** on headlight carrier.

Fig. 18

Drilling hole

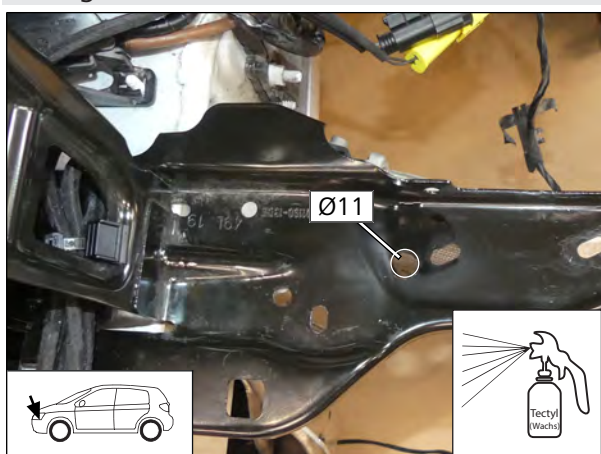
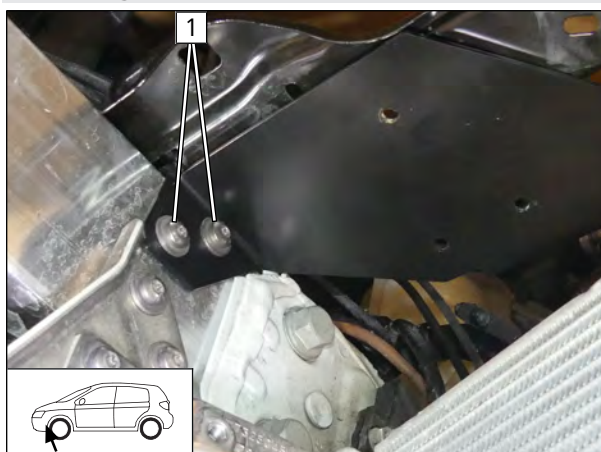

Fig. 19

Mounting heater bracket



- ▶ Mount HG bracket at pos. **1** with original vehicle bolts.

Fig. 20



8.2 Premounting heater



Observe the general installation instructions of the heater.

Mounting, aligning and fastening with 7Nm water connection piece with sealing ring and retaining plate

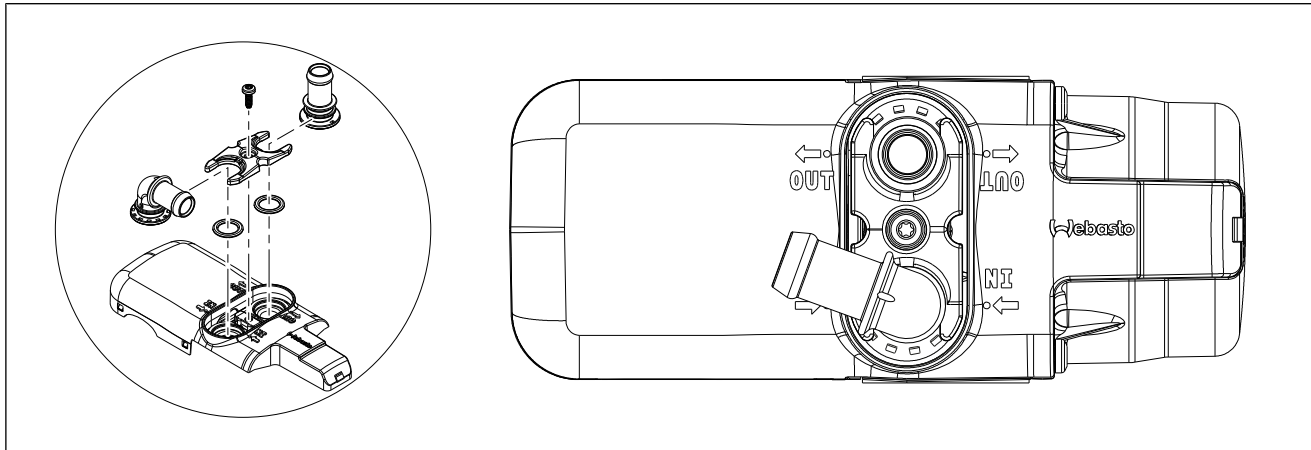

Fig. 21

Cutting combustion air intake pipe to length

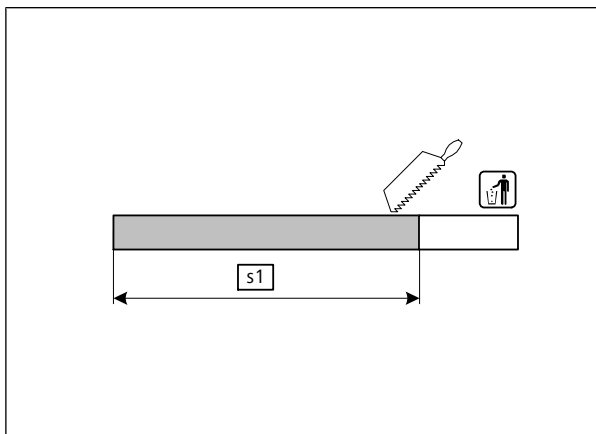
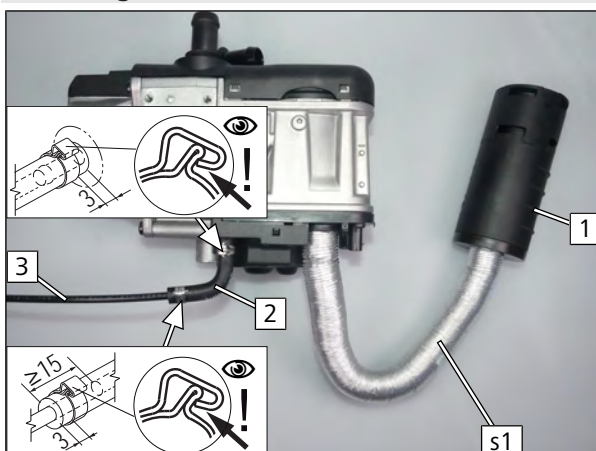

Fig. 22

s1 260

Mounting combustion air intake silencer and fuel line



Observe the installation instructions of the combustion air intake silencer.

- 1 Combustion air intake silencer
- 2 90° moulded hose; Ø10 clamp [2x]
- 3 Fuel line



8.3 Heater mounting

Mounting heater

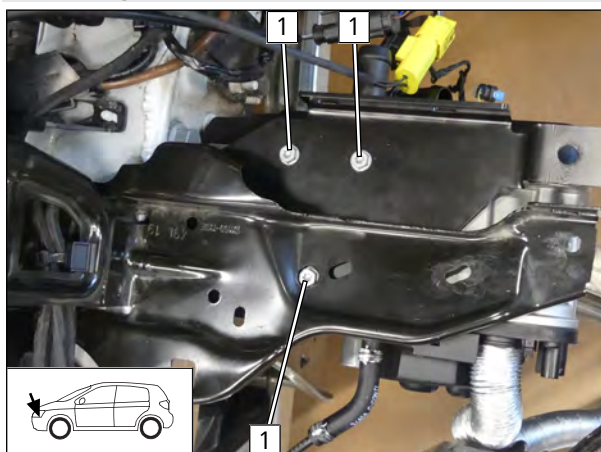

Fig. 23

- 1 5x13 self-tapping bolt

Installing wiring harness

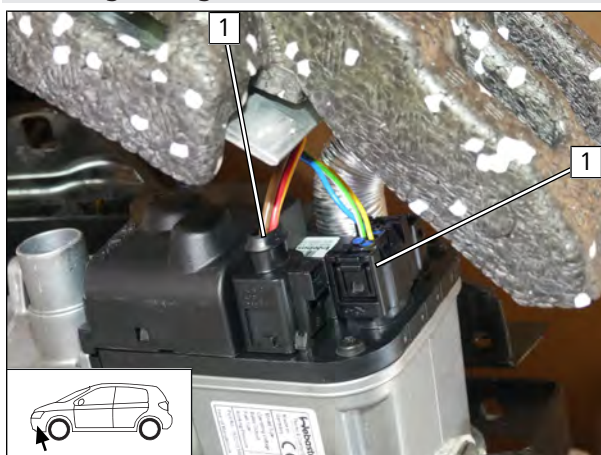

Fig. 24

- 1 Heater wiring harness connector



9 Fuel



DANGER

Risk of fire and explosion due to leaking fuel and escaping fuel vapours.

The incorrect installation of the fuel extractor can cause damage and fire.

- ▶ Avoid electrostatic discharges and open fire
- ▶ When working on the fuel system, ensure sufficient ventilation and bleeding
- ▶ Open the fuel tank cap of the vehicle
- ▶ Ventilate the fuel tank
- ▶ Re-close the tank lock
- ▶ Catch any fuel running off with an appropriate container



Danger of damage to components

- ▶ Install fuel line and fuel pump wiring harness so that they are protected against stone impact
- ▶ Provide rub protection for fuel line and wiring harness in areas where there are sharp edges

Dismantling fuel pump connector X7

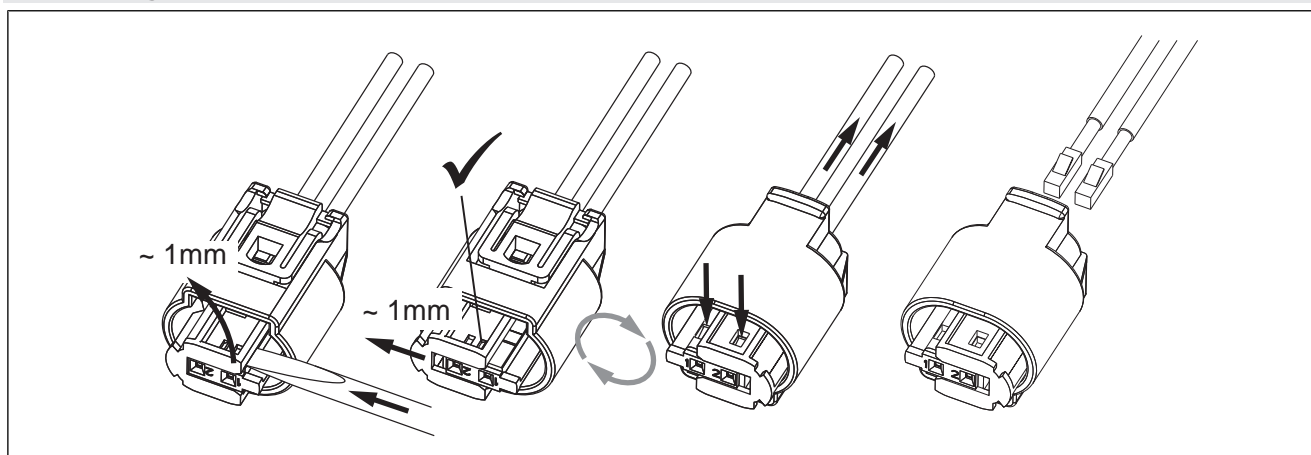

Fig. 25

9.1 Routing fuel line

Routing and fastening line



Fig. 26

- ▶ Draw fuel line and fuel pump wiring harness in Ø10 corrugated tube **1**, route along HG wiring harness into the engine compartment and fasten with cable ties.

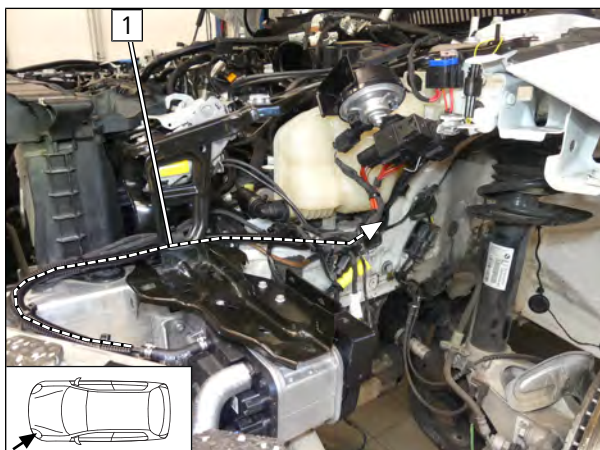

Fig. 27

- ▶ Route corrugated tube **1** as shown and fasten with cable ties.

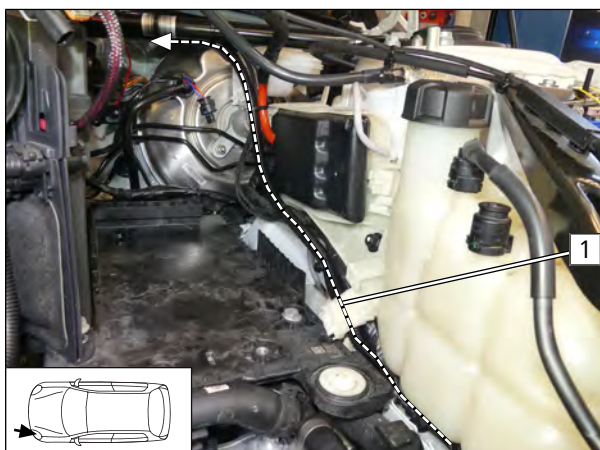

Fig. 28

- ▶ Route corrugated tube **1** along the passenger compartment wiring harness to the strut brace and fasten with cable ties.

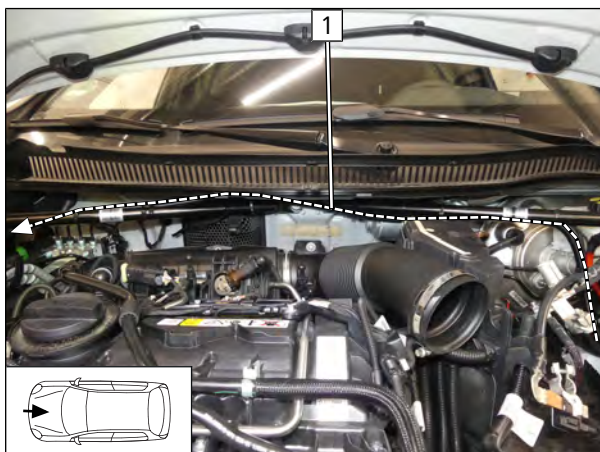

Fig. 29

- ▶ Route corrugated tube **1** along the strut brace to the front passenger's side and fasten with cable ties.



Fig. 30



Ensure sufficient distance between corrugated tube and Service connection, correct if necessary.



- ▶ Guide corrugated tube **1** through seal **2**, route it along the original vehicle fuel lines to the underbody and fasten it with cable ties.

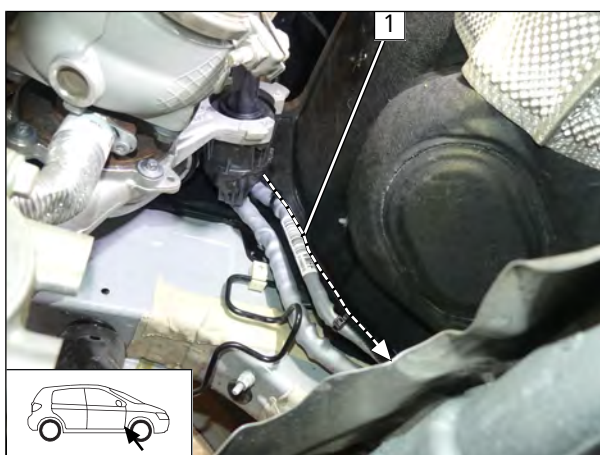

Fig. 31

- ▶ Route corrugated tube **1** along the original vehicle fuel lines to the underbody and fasten it with cable ties.

Drilling hole, inserting rivet nut

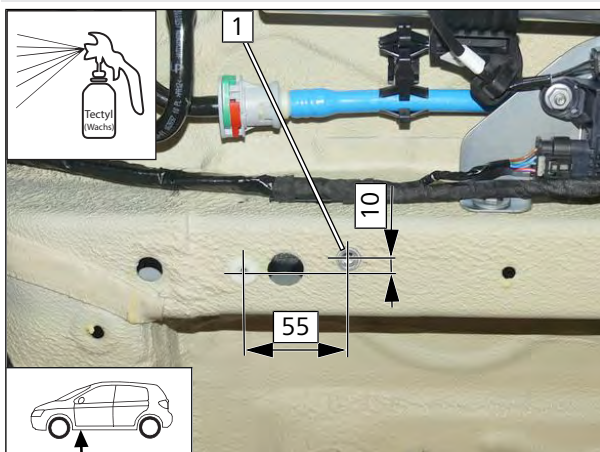

Fig. 32

- 1** Ø9 hole, rivet nut



Premounting fuel pump

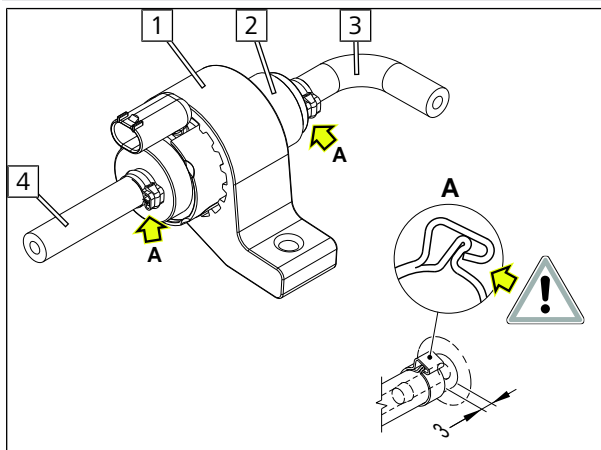

Fig. 33



The alignment of the fuel pump and fuel hoses will be carried out afterwards, during the installation.

- 1 Fuel pump mount
- 2 Fuel pump
- 3 90° moulded hose, Ø10 clamp
- 4 Hose section, Ø10 clamp

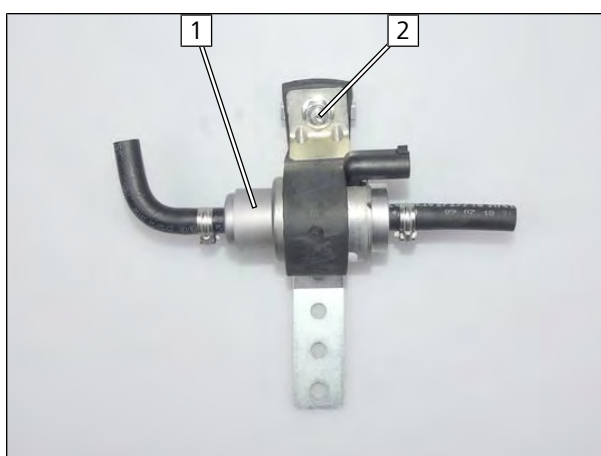

Fig. 34

- 1 Fuel pump
- 2 M6x25 bolt, support angle bracket, fuel pump mount, perforated bracket, flanged nut

Mounting fuel pump

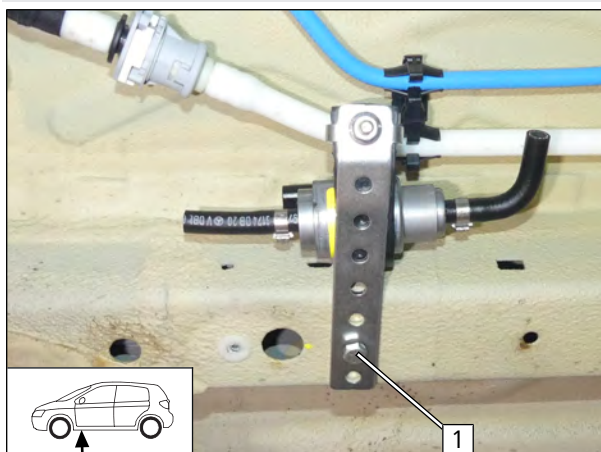

Fig. 35

- 1 M6x20 bolt, spring lockwasher, perforated bracket, rivet nut



Assembling fuel pump connector X7

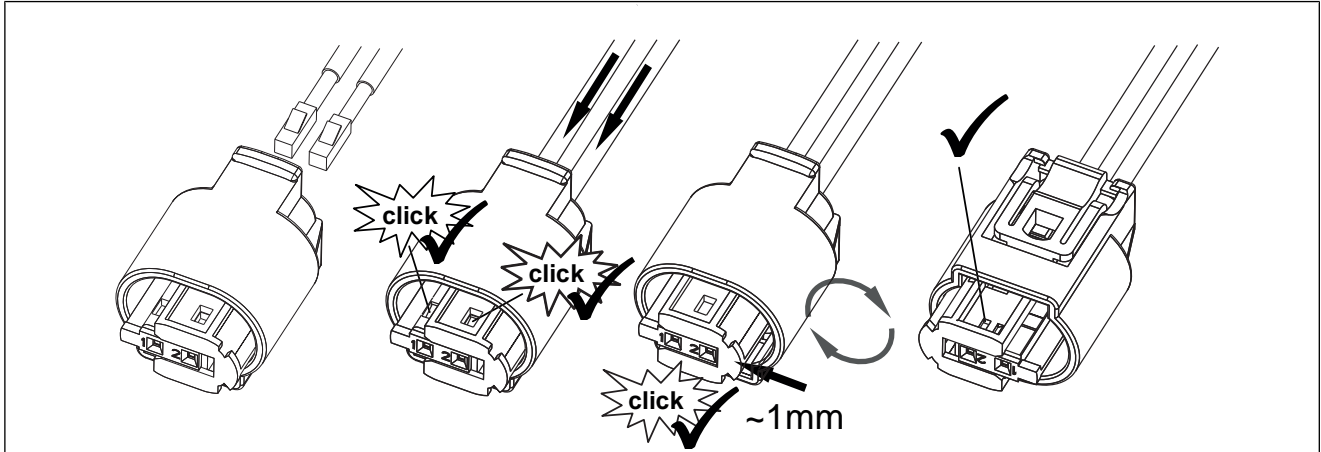

Fig. 36

Connecting fuel pump

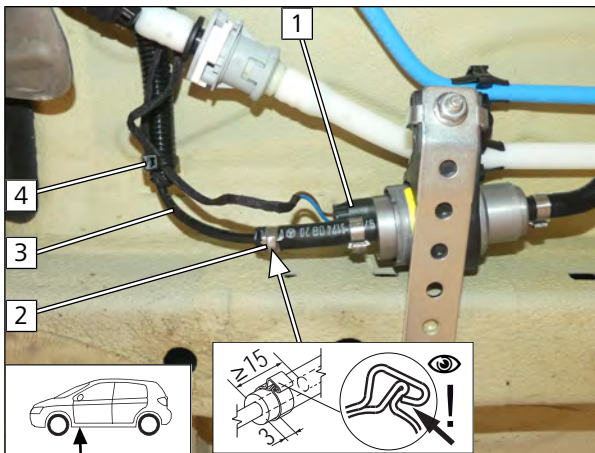

Fig. 37



Danger of damage to components

► Ensure sufficient distance from neighbouring components, correct if necessary.

- 1 Fuel pump wiring harness, connector X7 mounted
- 2 Ø10 clamp
- 3 Heater fuel line
- 4 Cable tie

Connecting fuel pump

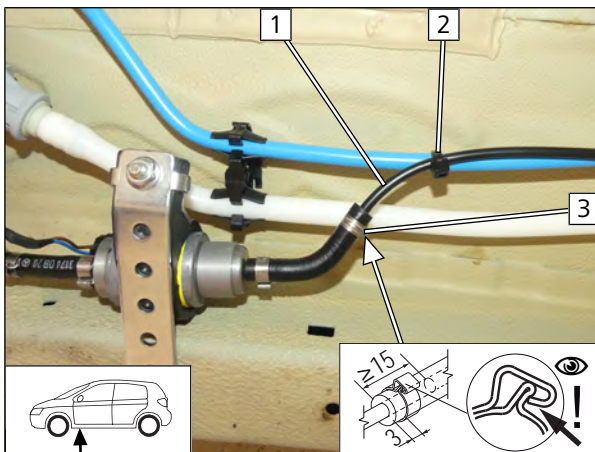

Fig. 38



Danger of damage to components

► Ensure sufficient distance from neighbouring components, correct if necessary.

- 1 Fuel line of FuelFix
- 2 Cable tie
- 3 Ø10 clamp



Routing line on underbody

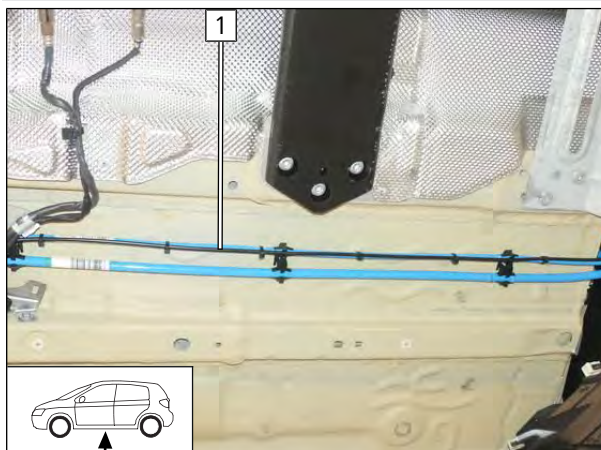

Fig. 39

- ▶ Route fuel line of FuelFix **1** along the original vehicle fuel line to the tank fitting.

Removing tank fitting service lid



Fig. 40

- ▶ Turn the tank fitting service lid to remove it.

9.2 Installing FuelFix

Moving label on tank fitting

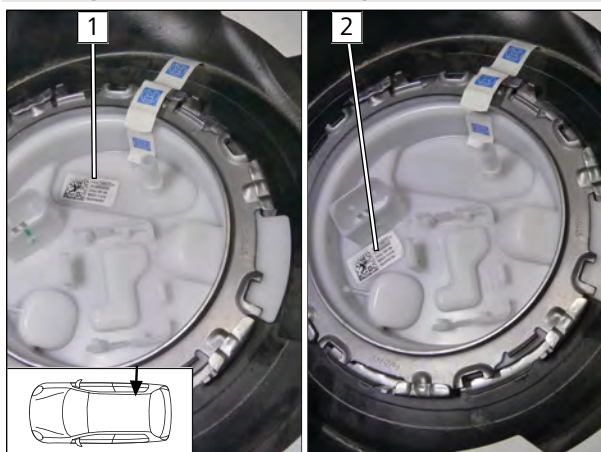

Fig. 41

- 1** Original position of label
- 2** New position of label



Preparing drilling template

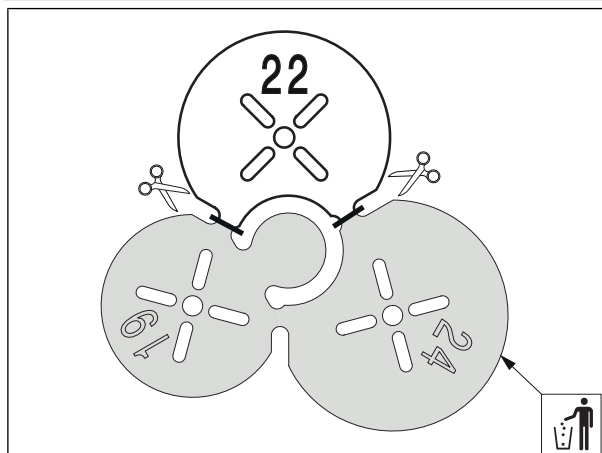

Fig. 42

Work steps F1, F2

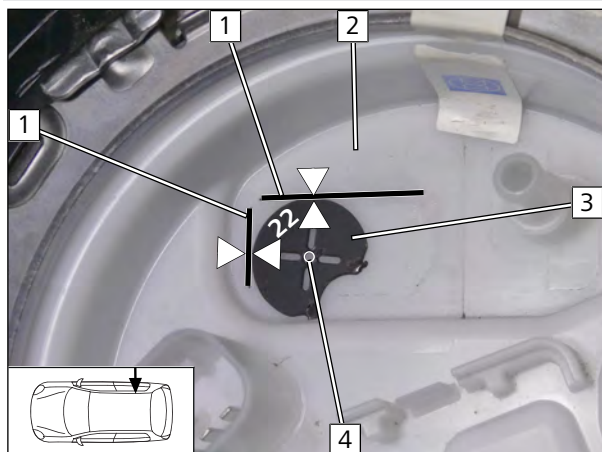

Fig. 43



Observe the installation instructions of the tank extracting device.

► Draw guide line **1** on existing embossing.

- 2** Tank fitting
- 3** Position Ø22 drilling template as shown in fig.
- 4** Hole pattern

Work step F3

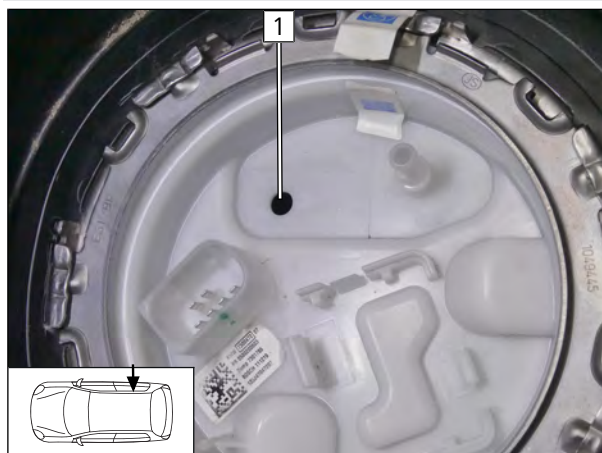

Fig. 44



DANGER

Risk of fire and explosion due to leaking fuel and escaping fuel vapours.

- 1** Hole made with provided drill



Work steps F4, F5

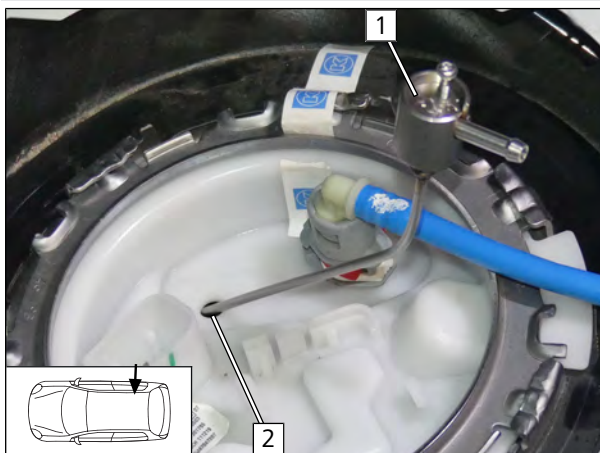

Fig. 45

- Bend FuelFix **1** according to template and cut to length. Insert in hole **2**.

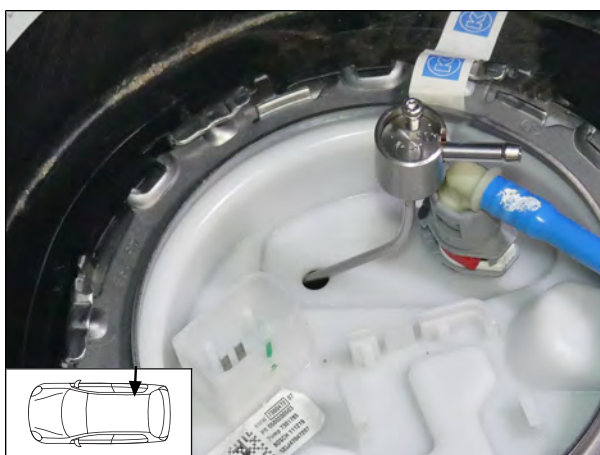

Fig. 46

Work steps F5.3, F5.4

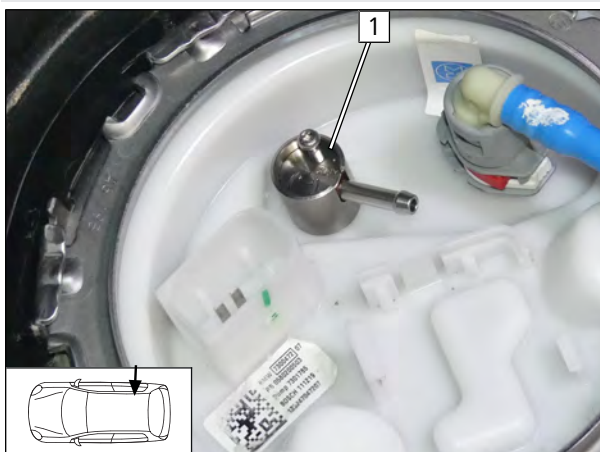

Fig. 47

- Align FuelFix **1** as shown.



Work step F6.1

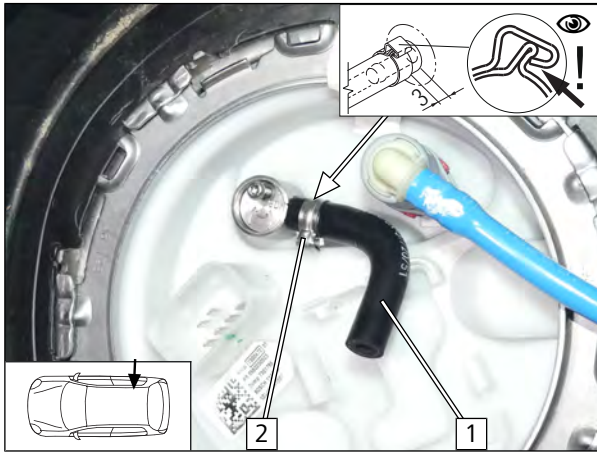

Fig. 48

- 1 90° moulded hose
- 2 Ø10 clamp

Work step F7

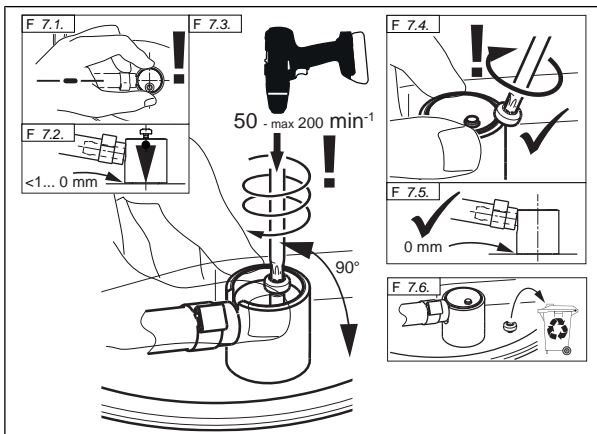

Fig. 49



DANGER

Risk of fire and explosion due to leaking fuel and escaping fuel vapours.

Work step F6.2

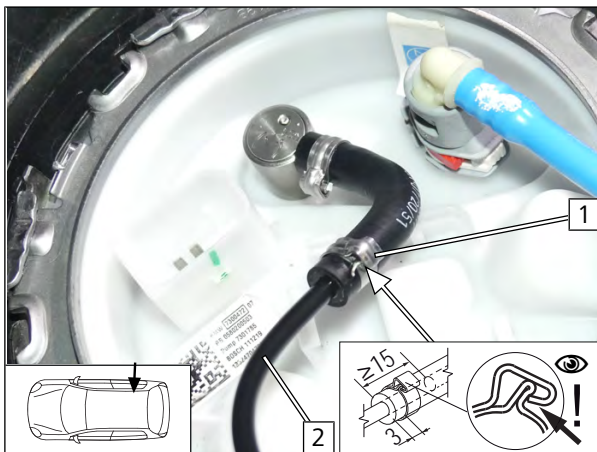

Fig. 50

- 1 Ø10 clamp
- 2 Fuel line



Work step F8



Fig. 51

Securing fuel line

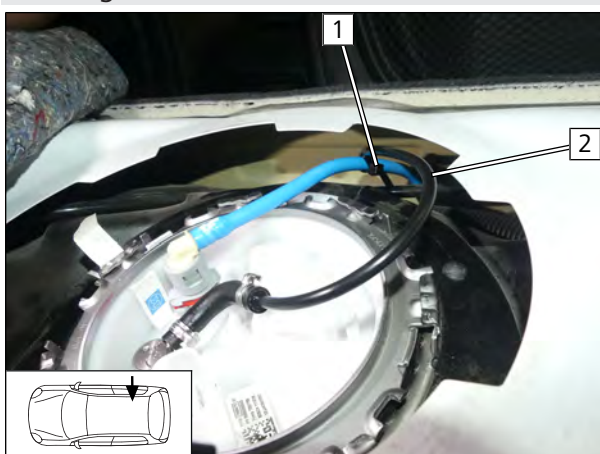

- 1 Cable tie for tension relief
- 2 Fuel line of FuelFix

Fig. 52



10 Exhaust part 1

Cutting exhaust pipe to length

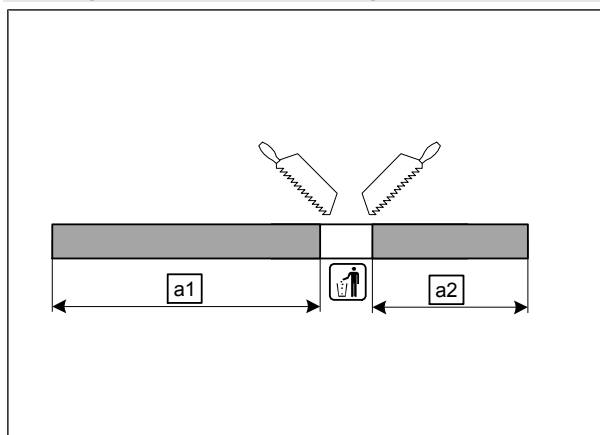

a1 550

a2 310

Fig. 53

Bending angle bracket

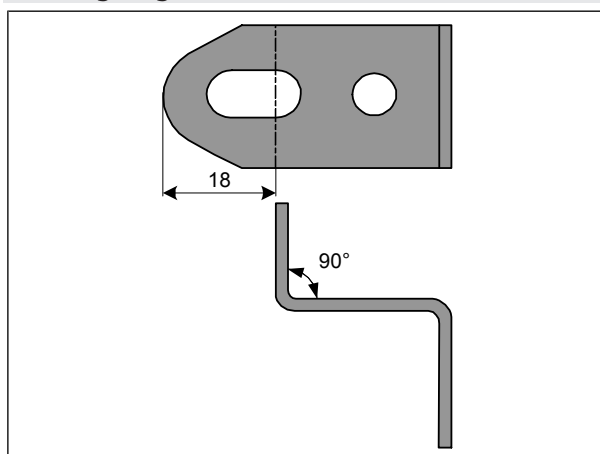

Fig. 54

Premounting exhaust silencer



- 1** M6x16 bolt, spring lockwasher, angle bracket, exhaust silencer

Fig. 55



Drilling hole, inserting rivet nut

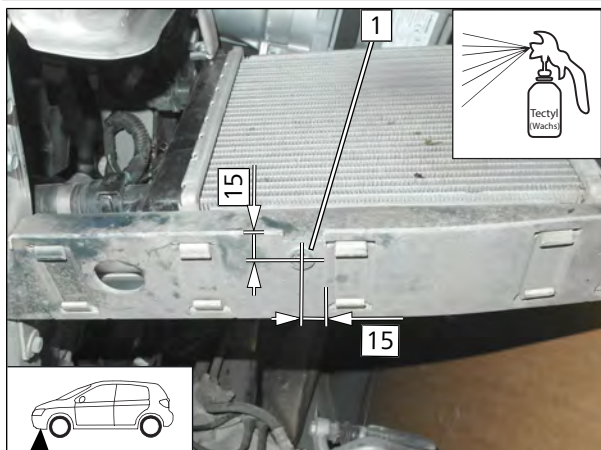
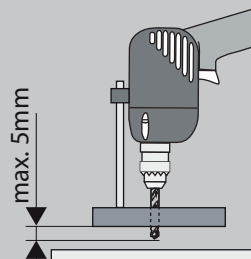

Fig. 56



Danger of damage to components



- 1 Ø9 hole, M6 rivet nut

Adapting frame

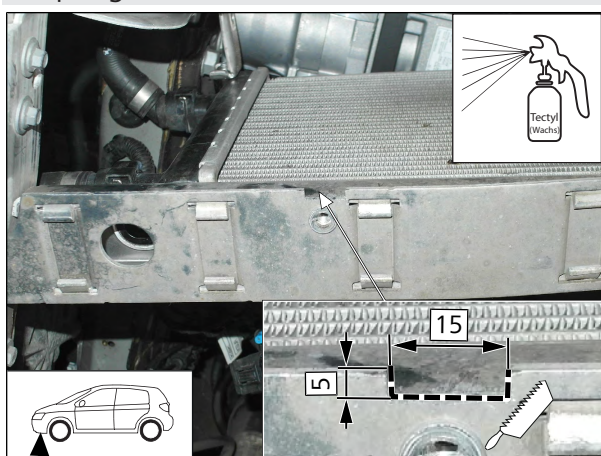

Fig. 57

Mounting and routing exhaust pipe **a1**

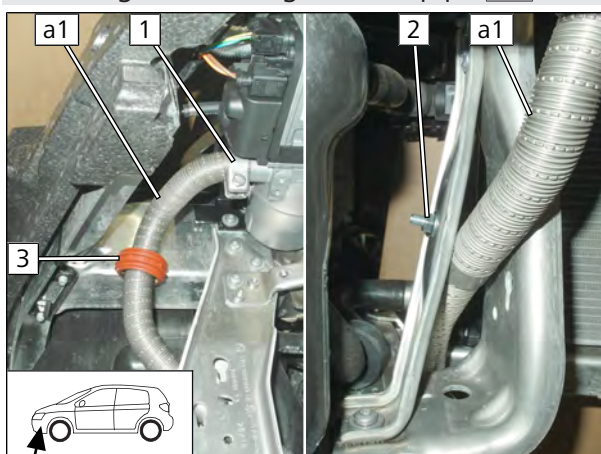
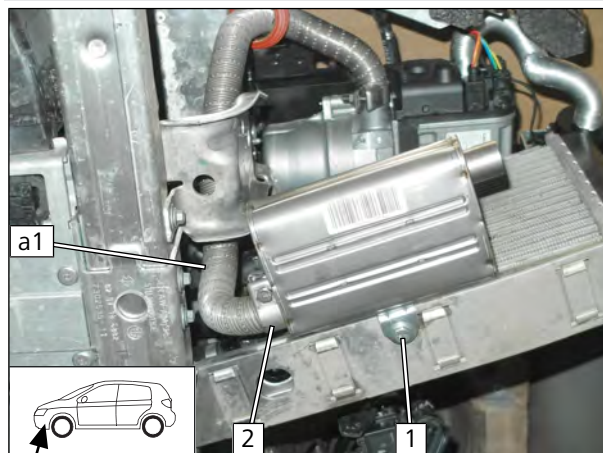

Fig. 58

- 1 Hose clamp
- 2 Clamp, M6x20 bolt, lock washer, original vehicle oblong hole, flanged nut
- 3 Aligning spacer bracket



Mounting exhaust silencer



- 1** M6x25 bolt, premounted exhaust silencer, rivet nut
- 2** Hose clamp

Fig. 59



11 Coolant

11.1 Preliminary Work

Preparing perforated bracket

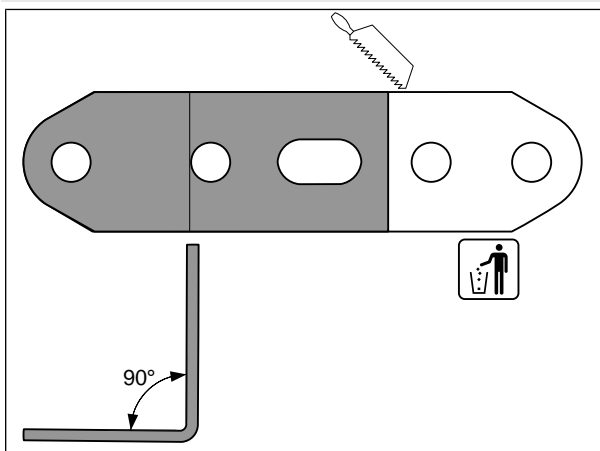

Fig. 60

Mounting headlight

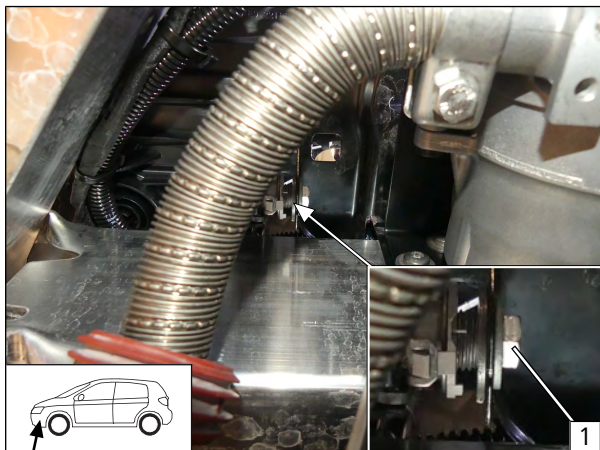

Fig. 61

- 1 Replace original vehicle bolt with M6x40 bolt, large diameter washer

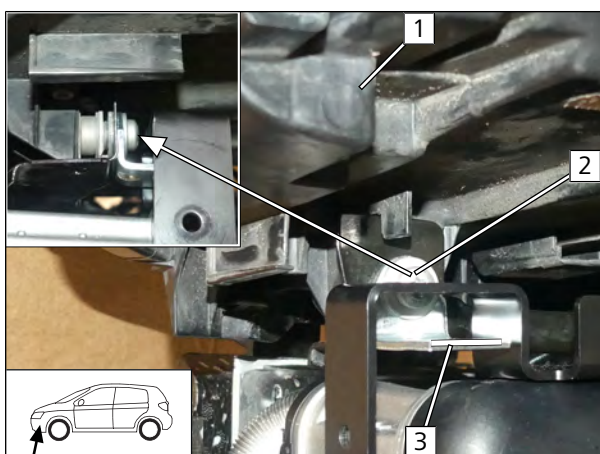

Fig. 62



► Align headlight **1**. Check the width of the gap between the headlight and the wing and bumper, correct if necessary.

- 2 Original vehicle bolt, perforated bracket, original vehicle headlight bracket, nut
- 3 Straighten perforated bracket

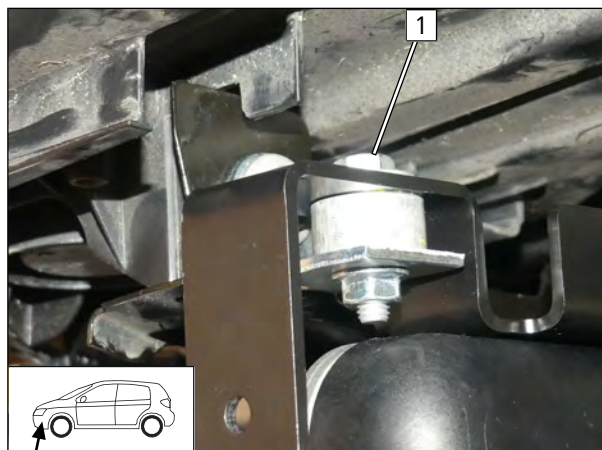

Fig. 63

- 1 M6x25 bolt, large diameter washer, HG bracket, spacer (10), perforated bracket, flanged nut

Checking distance

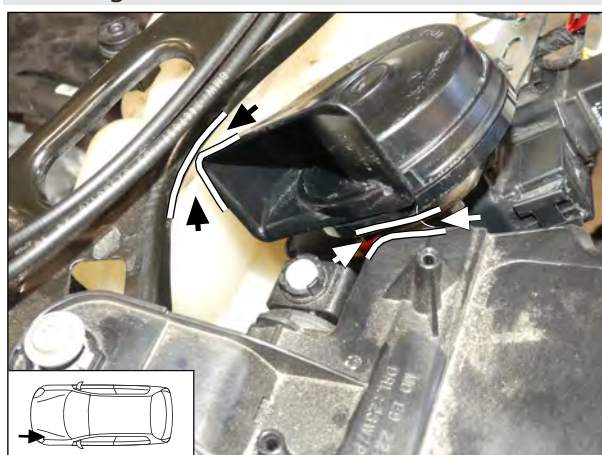
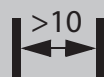

Fig. 64



Ensure sufficient distance from neighbouring components, correct if necessary.



Preparing angle bracket

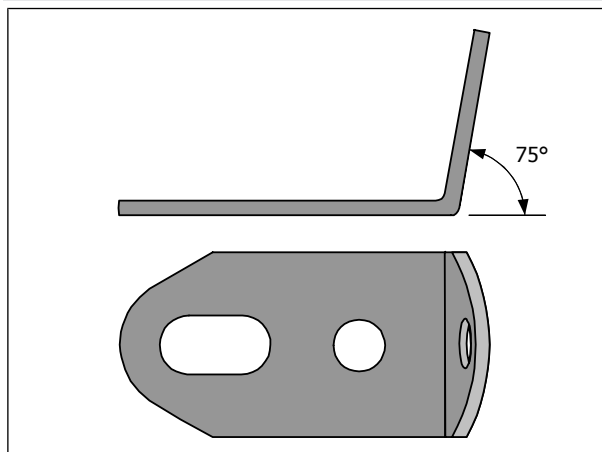

Fig. 65



Mounting angle bracket

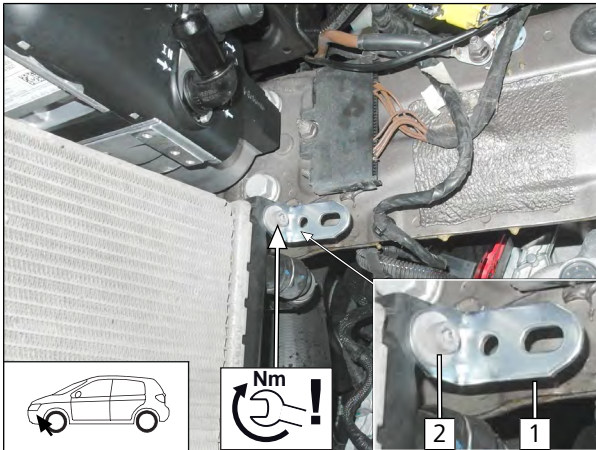

Fig. 66

- 1 Angle bracket
- 2 Original vehicle bolt, angle bracket, original vehicle thread

Preparing perforated bracket

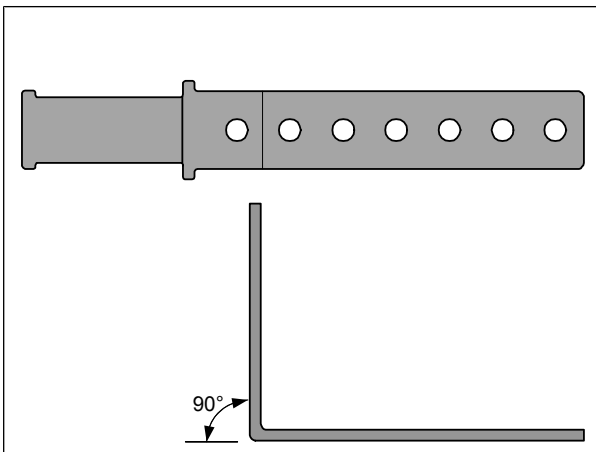

Fig. 67

Installing perforated bracket

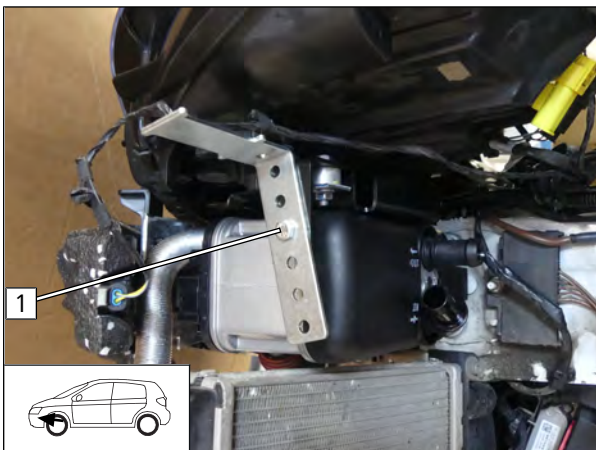
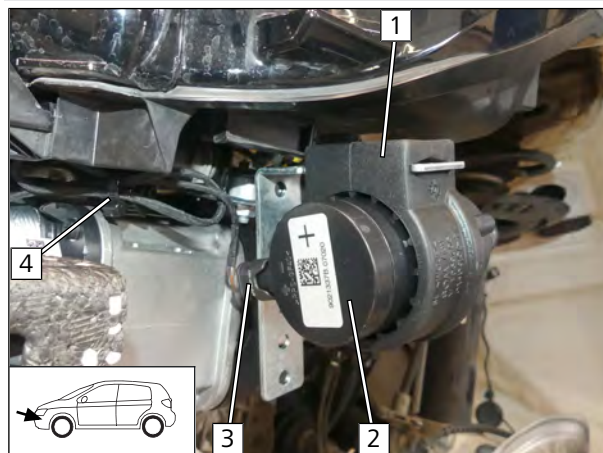

Fig. 68

- 1 M6x12 bolt, prepared perforated bracket, hole in heater bracket, mount flanged nut loosely



Mounting coolant pump



- 1 Coolant pump mount
- 2 Coolant pump
- 3 Coolant pump wiring harness connector
- 4 Cable tie

Fig. 69



11.2 Hose routing diagram

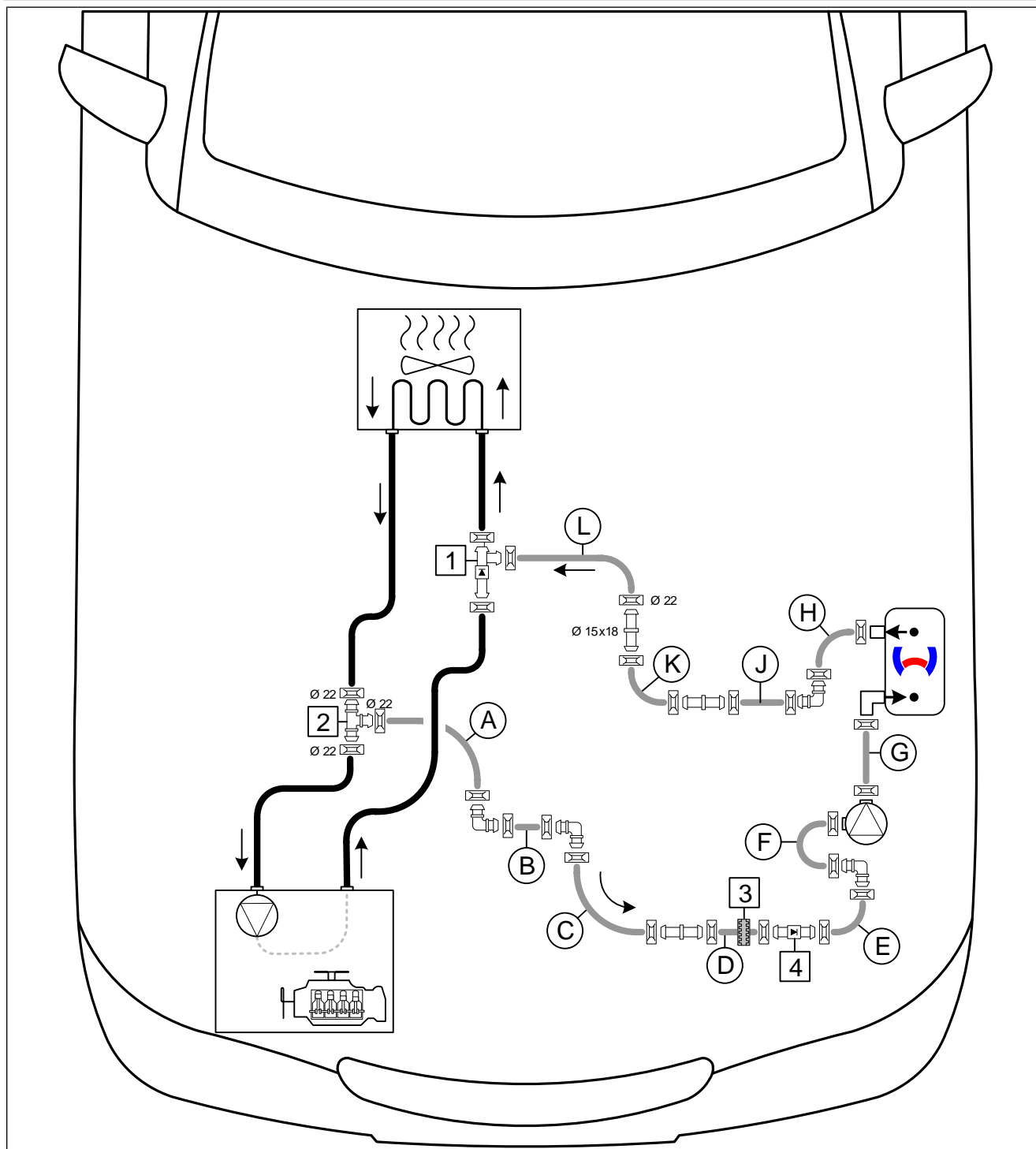



Fig. 70

► All spring clips without a specific designation  = Ø25

► All connecting pipes without a specific designation  or  = Ø18x18

1 Ø18x18x18 non-return valve; **2** Ø15x15x15 T-piece; **3** black (sw) rubber isolator; **4** Ø18x18 non-return valve



11.3 Coolant circuit installation

Preparing moulded hose

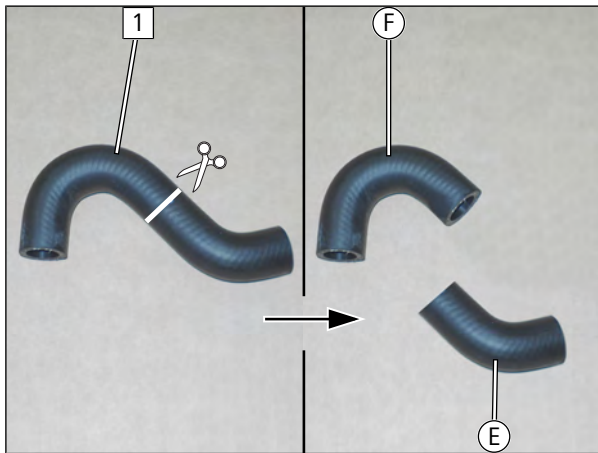

Fig. 71

► Cut provided moulded hose **1** as shown.

Cutting hoses to length

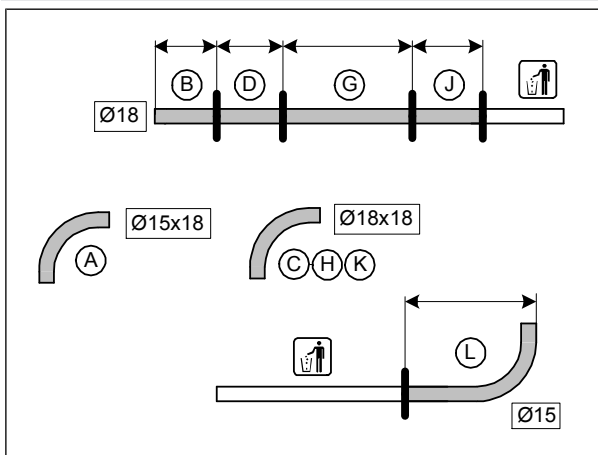

Fig. 72

(A)	90° moulded hose
(B)	90
(C, H, K)	90° moulded hose
(D)	90
(E)	Prepared moulded hose
(F)	Prepared moulded hose
(G)	170
(J)	70
(L)	180

Preparing non-return valve 1

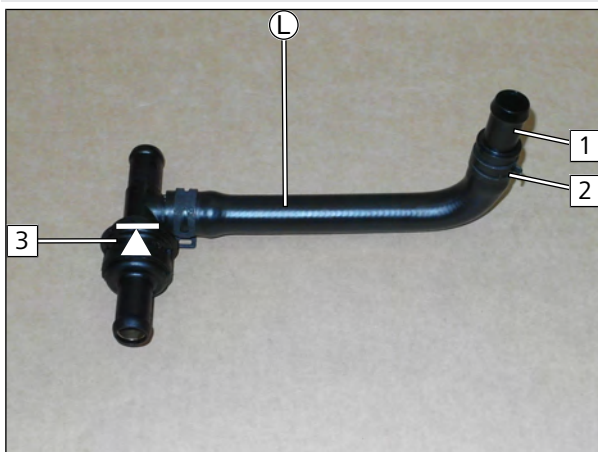

Fig. 73

- 1** Ø15x18 connecting pipe
- 2** Ø22 spring clip
- 3** Non-return valve 1



Cutting point 1

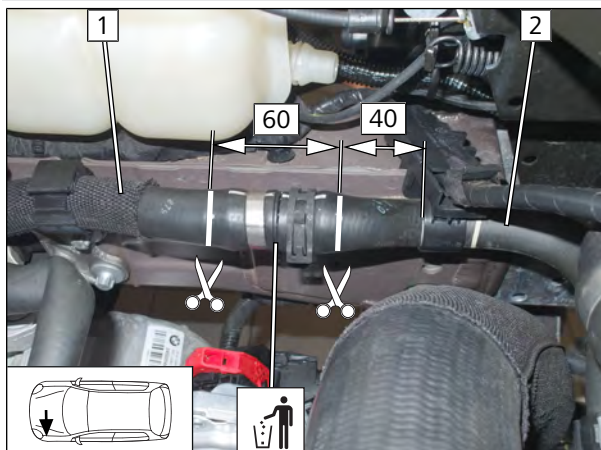

Fig. 74

► Cut engine outlet/heat exchanger inlet hose as shown.

- 1 Heat exchanger inlet hose section
- 2 Engine outlet hose section

Mounting non-return valve 1

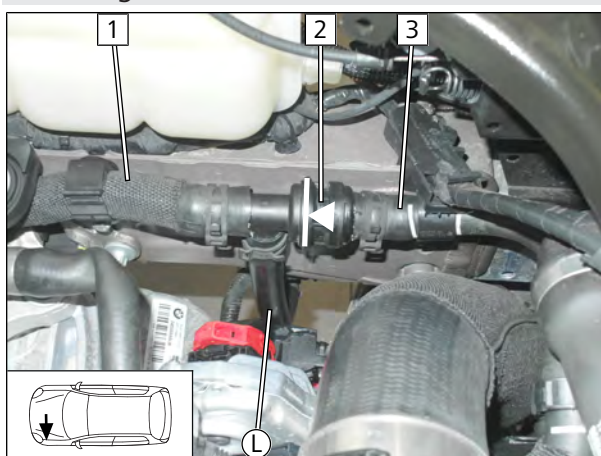

Fig. 75

- 1 Heat exchanger inlet hose section
- 2 Pre-mounted non-return valve 1
- 3 Engine outlet hose section

Heater outlet connection

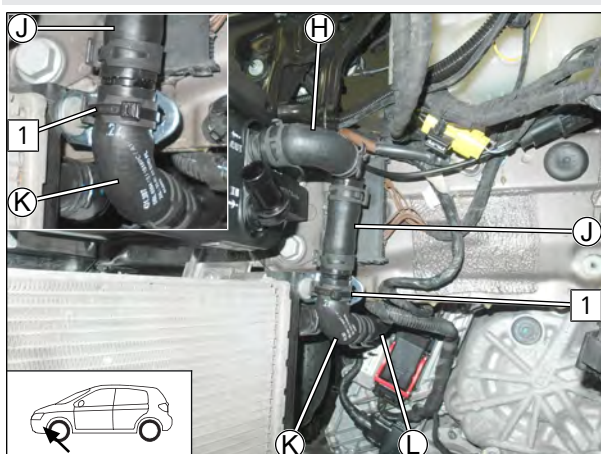

Fig. 76

► Fasten hoses to angle bracket with cable tie 1.



Checking distance

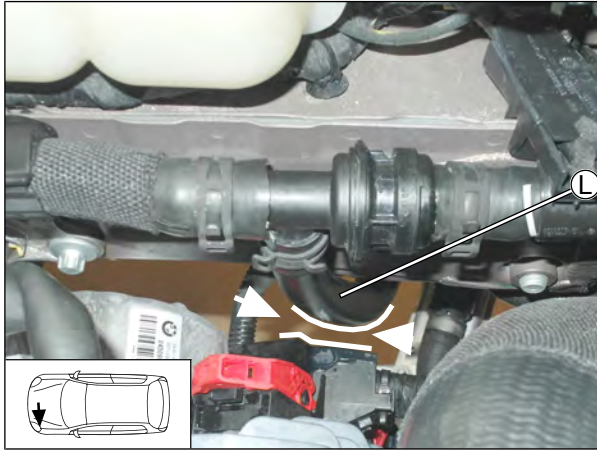

Fig. 77



Danger of damage to components

- ▶ Ensure sufficient distance between hose and transmission, correct if necessary.

Mounting hose ①

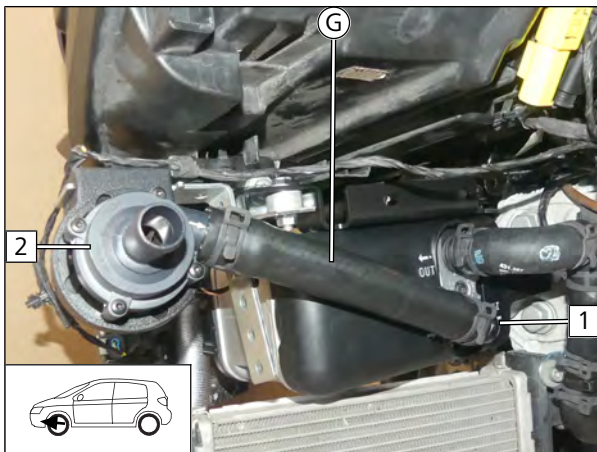

Fig. 78

- 1 Heater/IN connection piece
- 2 Coolant pump

Preparing non-return valve 2

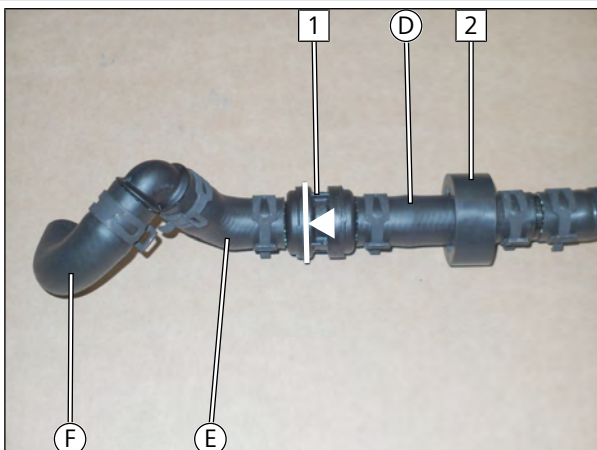

Fig. 79

- 1 Non-return valve 2
- 2 Black (sw) rubber isolator



Mounting T-piece

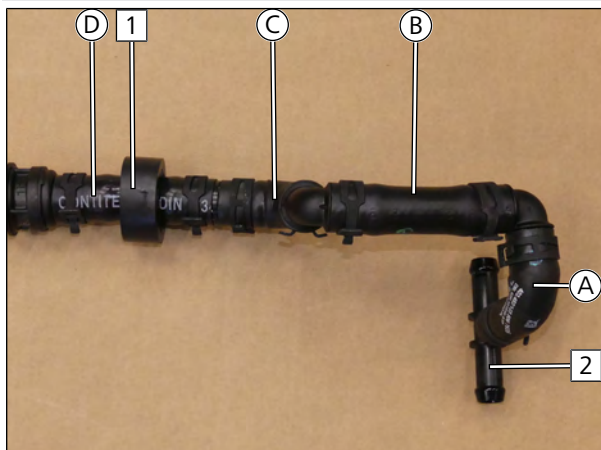

Fig. 80

- 1 Black (sw) rubber isolator
- 2 15x15x15 T-piece

Overall view of hose group



Fig. 81

Cutting point 2

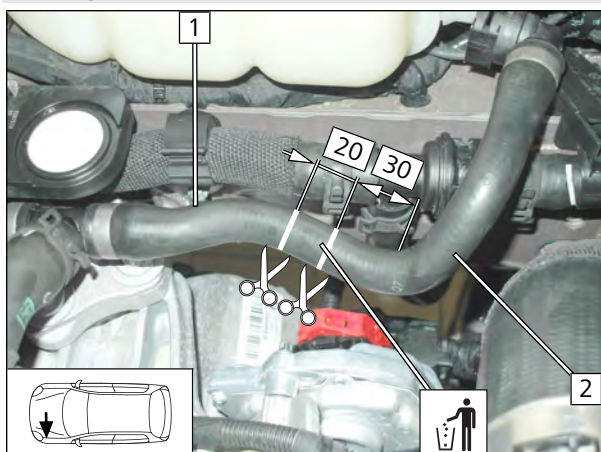

Fig. 82

► Cut engine inlet/ heat exchanger outlet hose as shown.

- 1 Heat exchanger outlet hose section
- 2 Expansion tank hose section



Connecting T-piece

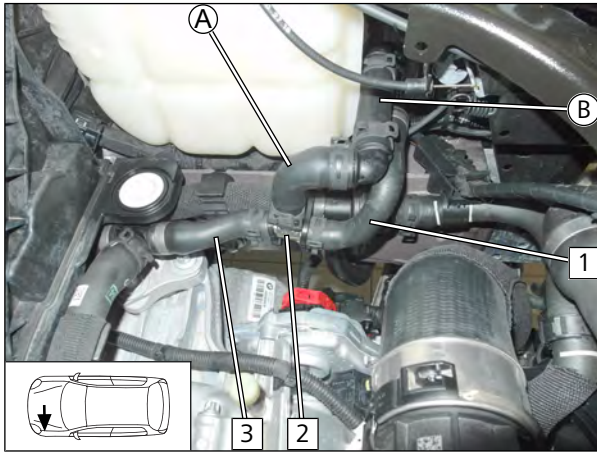

Fig. 83

- 1 Expansion tank hose section
- 2 T piece
- 3 Heat exchanger outlet hose section

Connection of hose (F) to coolant pump, fastening hoses

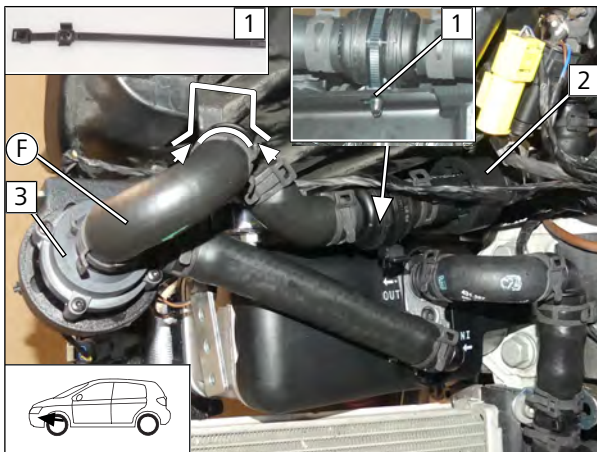

Fig. 84



Ensure sufficient distance from neighbouring components, correct if necessary.



- 1 Eyelet cable tie in available hole of headlight carrier
- 2 Align black (sw) rubber isolator with headlight
- 3 Coolant pump

Checking distance, fastening hoses

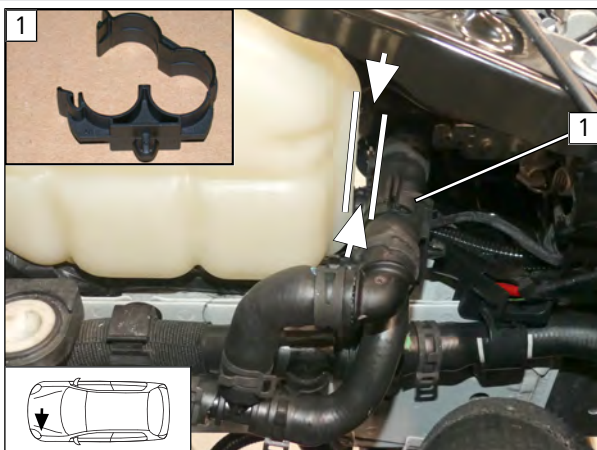

Fig. 85



Ensure sufficient distance between hoses and expansion tank, correct if necessary.



- 1 Hose bracket



Aligning spring clips

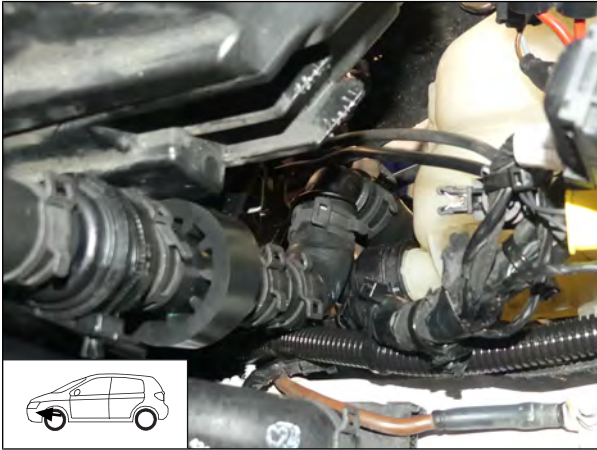

Danger of damage to components

► Ensure correct orientation of the spring clips.

Fig. 86



12 Combustion air

Installing cable tie

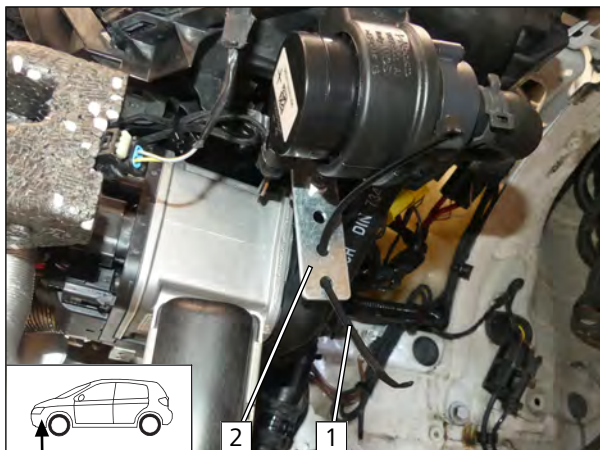

- 1 Cable tie
- 2 Coolant pump perforated bracket

Fig. 87

Mounting combustion air intake silencer

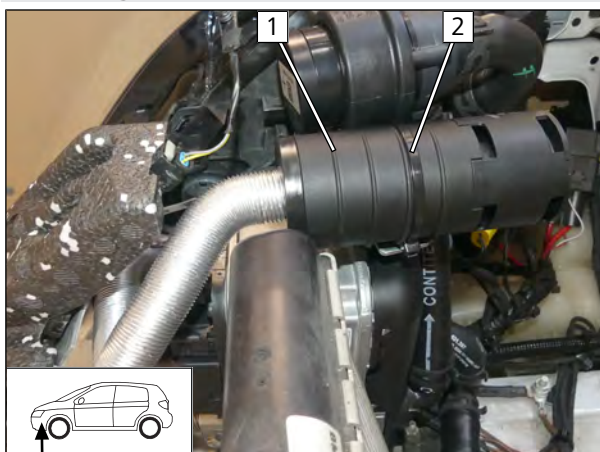

- 1 Combustion air intake silencer
- 2 Close cable tie

Fig. 88



13 Exhaust part 2

Mounting air duct loosely

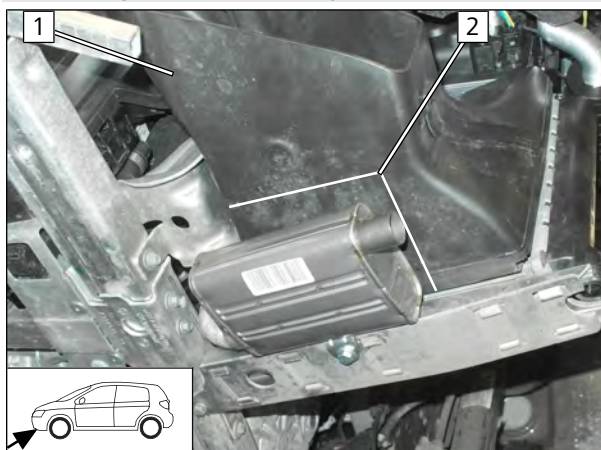

- ▶ Copy outline **2** of exhaust silencer onto air duct **1** as shown.
- ▶ Remove air duct.

Fig. 89

Sticking heat protection film in marked area

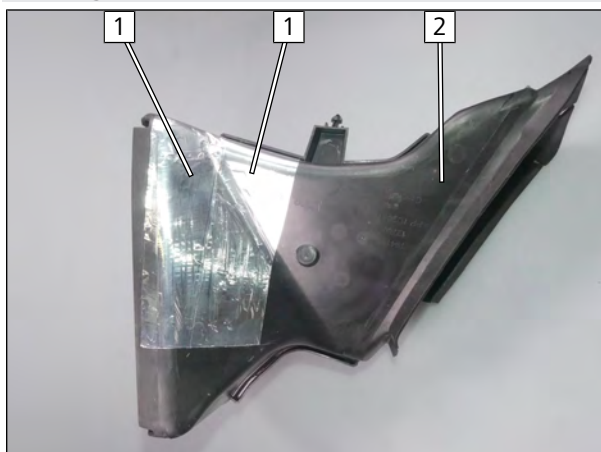

- ▶ Cut heat protection film in half.
 - 1** 150 long heat protection film
 - 2** Air duct

Fig. 90

Mounting air duct

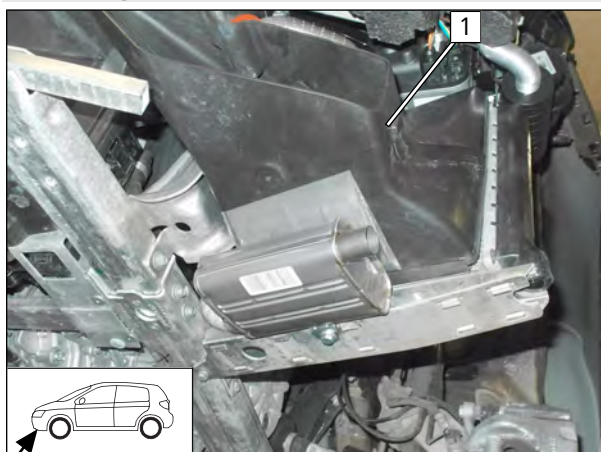

- 1** Air duct

Fig. 91



EFIX installation - Work step E1

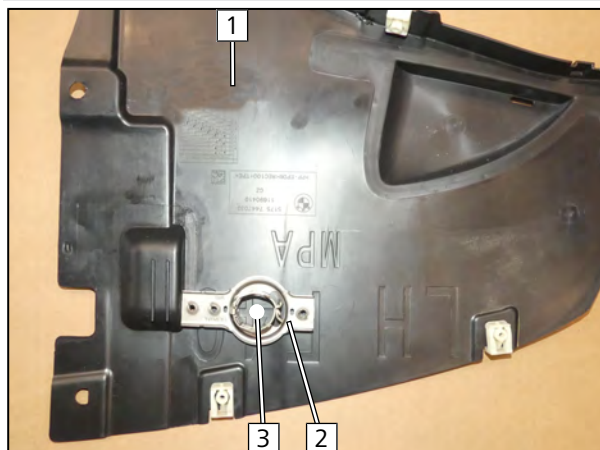

Fig. 92



Observe the EFIX installation instructions.

- 1 Wheel well trim
- 2 EFIX
- 3 Copy hole pattern

Work step E2

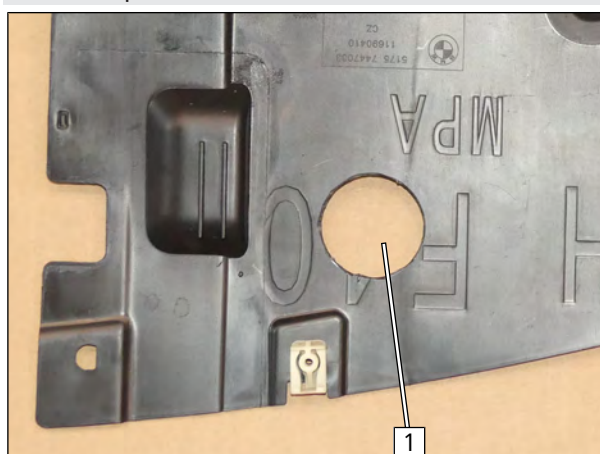

Fig. 93

- 1 Hole

Work step E3

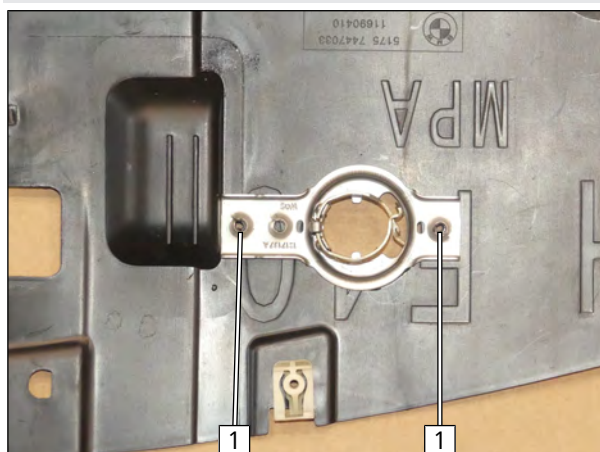

Fig. 94

- 1 Copy hole pattern



Work step E4

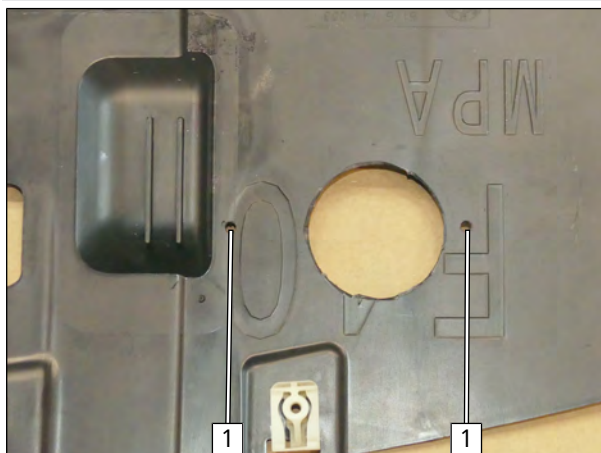

Fig. 95

1 Hole

Work step E5

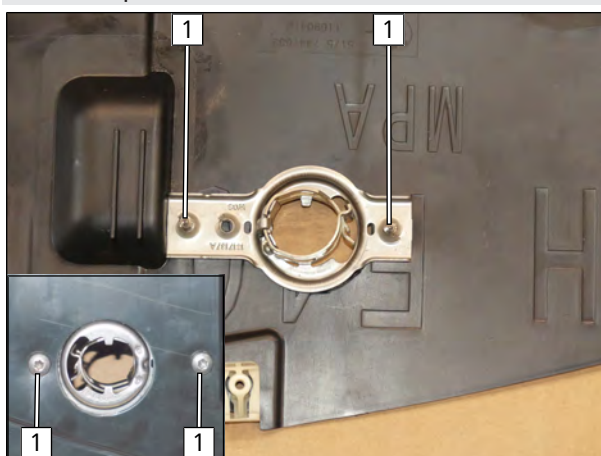

Fig. 96

1 5x13 self-tapping screw

Sticking on heat protection film

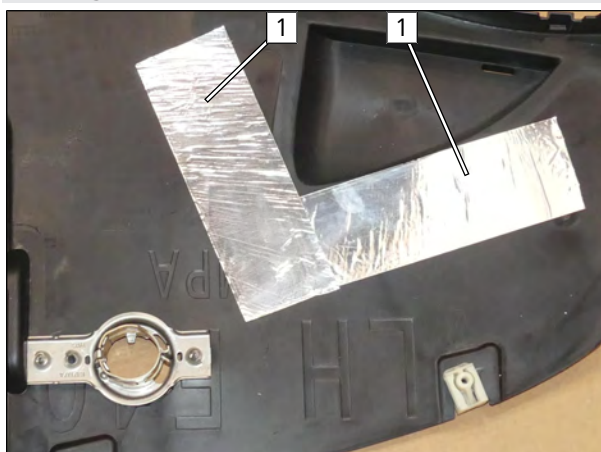

Fig. 97

- ▶ Cut heat protection film in half.
- ▶ Glue 150 long heat protection film 1 below the exhaust silencer on the wheel well trim.



Installing wheel well trim

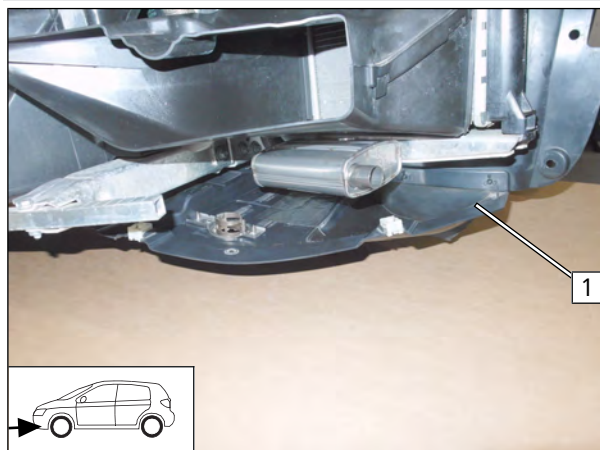

Fig. 98

- 1 Wheel well trim

Mounting exhaust pipe a2

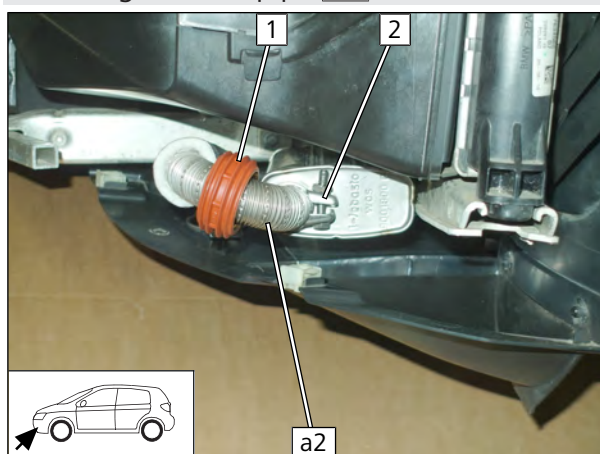

Fig. 99

- 1 Aligning spacer bracket
- 2 Hose clamp

Work steps E6-8

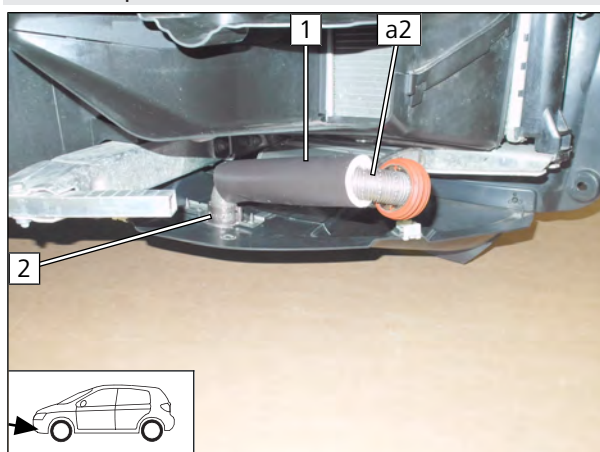

Fig. 100



Observe the EFIX installation instructions.

- 1 Heat protection
- 2 EFIX



Aligning exhaust pipe **a2**

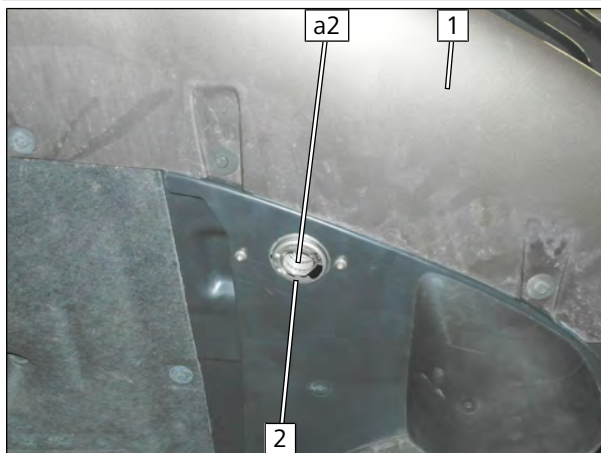

Danger of damage to components

► Ensure sufficient distance from neighbouring components, correct if necessary.

► Mount bumper **1**.

2 EFIX

Fig. 101



14 Electrical system of passenger compartment

14.1 Air-conditioning control

Integrate the air-conditioning control as per the separate installation documentation:



'Webasto Comfort' air-conditioning control installation documentation for AAC BMW



15 Final Work



Further information can be found in the vehicle manufacturer's technical documentation.

- ▶ Mount removed parts in reverse order.



- ▶ Check all hoses, clamps and all electrical connections for firm seating.
- ▶ Insulate and tie back loose lines
- ▶ Spray heater and electrical components with anti-corrosion wax (Tectyl 100K).
- ▶ Connect the battery.



Only use manufacturer-approved coolant.

- ▶ Fill and bleed the coolant circuit according to the vehicle manufacturer's specifications.



Further information can be found in the general installation and operating instructions of the Webasto components.

- ▶ Teach Telestart transmitter
- ▶ If the fan function or A/C control panel settings need to be checked, see the installation documentation in the additional kit 'Webasto Comfort' A/C control, section 'Final work'
- ▶ Initial start-up and function check
- ▶ Affix 'Switch off parking heater before refueling' caution label in area of filler neck



Vehicle event log after parking heating mode

- ✓ Components of the original vehicle air conditioning system are activated during parking heating mode. Other vehicle components remain inactive, which in some circumstances may be interpreted as an error and can be filed as such in the event log. An increased power consumption (quiescent current) may also be registered for some vehicles.
- ▶ If an incorrect installation can be excluded, these entries are exclusively related to the parking heating mode situation and have no effect on the vehicle functions in driving mode.

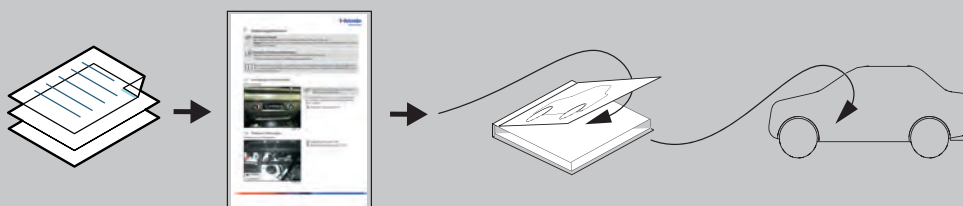

These are the original instructions. The German language is binding.
You can request your language if it is missing. The telephone number of each country can be found in the Webasto service centre leaflet or the website of the respective Webasto representative of your country.

© Copyright 2021 - The contents of this document, including but not limited to text, photographs and graphics, are protected by copyright. All rights, including reproduction, publication, editing and translation in any way, shape or form, are reserved by Webasto.

Webasto Thermo & Comfort SE
Postfach 1410
82199 Gilching
Germany

Company address:
Friedrichshafener Str. 9
82205 Gilching
Germany

Technical Extranet: <https://dealers.webasto.com>



WWW.WEBASTO.COM



16 FuelFix template

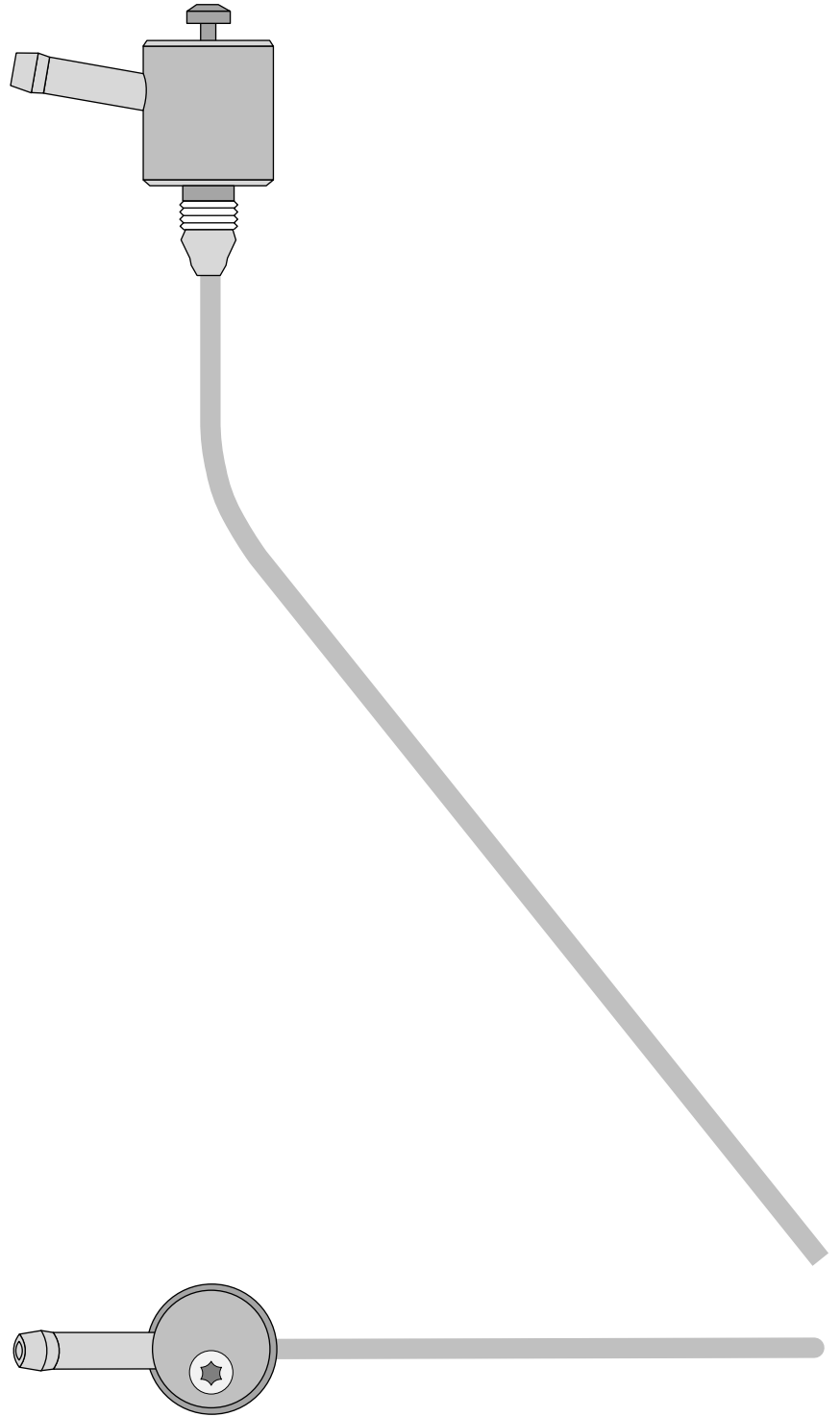

100mm



**Set print option to custom scale on 100%.
Check scale 1:1 for print output.**

0

100mm

