

# K Installation documentation

for water heater Thermo Top Evo

'Inline' coolant circuit with engine preheating

Skoda Octavia

Left-hand drive vehicle

Manufacturer	Model	Type	Model year	EG-BE-No. / ABE
Skoda	Octavia	NX	from 2020	E8*2007/46*0355*...

Motorisation	Fuel	Emission standard	Transmission type	Output [kW]	Displacement [cm <sup>3</sup> ]	Engine code
2.0D	Diesel	Euro 6d Temp	DKG	110	1968	DSTB

Validity	Equipment variants	Model
		Octavia
Verified equipment variants	2 zone automatic air-conditioning	x
	3 zone automatic air-conditioning	x
	Matrix LED headlights	x
	LED daytime running lights	x
	Dynamic cornering light	x
	Keyless Go	x
	Automatic Start-Stop system	x
	Start button	x

Total installation time	Note
7.5 hours	

---

# Contents

<b>1</b>	<b>List of abbreviations</b>	<b>3</b>	<b>13</b>	<b>Electrical system of passenger compartment</b>	<b>48</b>
<b>2</b>	<b>Installation notes</b>	<b>4</b>	13.1	Preliminary Work	48
2.1	Information on Validity	4	13.2	Wiring diagram	51
2.2	Components used	4	13.3	Fan controller	53
2.3	Notes on installation, in coordination with the end customer	4	13.4	Connection of Cronus to push button	55
2.4	Information on Total Installation Time	4	13.5	Heater connection and installation of Tele-start or MultiControl AM control element	55
<b>3</b>	<b>About this document</b>	<b>5</b>	13.6	Heater connection and installation of ThermoConnect control element	56
3.1	Purpose of the document	5	<b>14</b>	<b>Final Work</b>	<b>57</b>
3.2	Warranty and liability	5	<b>15</b>	<b>Template of bracket</b>	<b>59</b>
3.3	Safety	5	<b>16</b>	<b>FuelFix drilling template</b>	<b>61</b>
3.4	Using this document	6	<b>17</b>	<b>FuelFix template</b>	<b>63</b>
<b>4</b>	<b>Technical Information</b>	<b>7</b>	<b>18</b>	<b>Operating instructions</b>	<b>65</b>
<b>5</b>	<b>Preparations</b>	<b>8</b>	18.1	Installation location of fuses	65
5.1	Vehicle preparation	8			
5.2	Heater preparation	8			
<b>6</b>	<b>Installation overview</b>	<b>9</b>			
<b>7</b>	<b>Electrical system of engine compartment</b>	<b>10</b>			
<b>8</b>	<b>Mechanical system</b>	<b>15</b>			
8.1	Installation location preparation	15			
8.2	Premounting heater assembly	16			
8.3	Heater assembly installation	22			
<b>9</b>	<b>Combustion air</b>	<b>24</b>			
<b>10</b>	<b>Fuel</b>	<b>26</b>			
10.1	Routing fuel line	26			
10.2	Installing FuelFix	31			
<b>11</b>	<b>Coolant</b>	<b>36</b>			
11.1	Preliminary work on vehicle	36			
11.2	Preparing hose group	38			
11.3	Hose routing diagram	43			
11.4	Coolant circuit installation	44			
<b>12</b>	<b>Final work in engine compartment</b>	<b>47</b>			

---

# 1 List of abbreviations

CR	Cronus (passenger compartment control unit)
DKG	Dual clutch transmission
DP	Fuel pump
FF	FuelFix (tank extracting device)
HG	Heater
MY	Model year
SH2	Engine compartment fuse holder for F1/F2/F3
UP	Coolant pump
Veh.	Vehicle

---

## 2 Installation notes

### 2.1 Information on Validity

This installation documentation applies to vehicles listed on page 1, assuming technical modifications to the vehicle do not affect installation, any liability claims excluded. Depending on the vehicle version and equipment, modifications may be necessary during installation with respect to this installation documentation. Vehicle and engine types, equipment variants and other specifications not listed in this installation documentation have not been tested. However, installation according to this installation documentation may be possible.

### 2.2 Components used

Designation	Order number
Delivery scope for Skoda Octavia diesel Cronus MY 2020 TT-Evo	1328203A
In case of Telestart, control element, as well as indicator lamp in consultation with end customer	In accordance with price list
The following must also be ordered for the ThermoConnect option: retrofitting Y adapter wiring harness	1319820_

### 2.3 Notes on installation, in coordination with the end customer

- ▶ Arrange for the vehicle to be delivered with the tank only about ¼ full.
- ▶ The installation location of the following elements should be chosen in coordination with the end customer:
  - the Cronus push button as well as the push button in case of the Telestart and/or ThermoConnect options
  - the MultiControl CAR option

### 2.4 Information on Total Installation Time

The total installation time includes the time needed for mounting and demounting the vehicle-specific components, the heater specific installation time and all other times required for the system integration and initial start-up of the heater.

The total installation time may vary for vehicle equipment other than provided.

---

## 3 About this document

### 3.1 Purpose of the document

This installation documentation is part of the product and contains all the information required to ensure professional vehicle specific installation of the:

Thermo Top Evo heater
-----------------------

### 3.2 Warranty and liability

Webasto shall assume no liability for defects, damage and injuries resulting from a failure to observe the installation, repair and operating instructions of the information contained in them.

This liability exclusion particularly applies to improper installations and repairs by untrained persons or in the case of a failure to use genuine spare parts.

The liability due to culpable disregard to life, limb or health and due to damage or injuries caused by a wilful or reckless breach of duty remain unaffected, as does the obligatory product liability.

Installation should be carried out according to the general, standard rules of technology. Unless specified otherwise, fasten hoses, lines and wiring harnesses to original vehicle lines and wiring harnesses using cable ties. Insulate loose wire ends and tie back. Connectors on electronic components must audibly snap into place during assembly.

Spray unfinished body areas, e.g. drilled holes, with anti-corrosion wax (Tectyl 100K).

Observe the instructions and guidelines of the respective vehicle manufacturer for demounting and mounting vehicle specific components.

The initial start-up is to be executed with the Webasto Thermo Test Diagnosis.

When installing a programmable control module (e.g. a PWM Gateway), the corresponding settings must be checked or adjusted.

#### 3.2.1 Statutory regulations governing installation

The Thermo Top Evo heater has been type-tested and approved in accordance with ECE-R 10 (EMC) and ECE-R 122 (heater). The regulations of these guidelines are binding in the scope of the Directive 70/156/EEC and/or 2007/46/EC (for new vehicle models from 29/04/2009) and should also be observed in countries in which there are no special regulations.

The heater is licensed in accordance with paragraph 19, section 3, No. 2b of the StVZO (German Road Traffic Licensing Authority).

### 3.3 Safety

#### Qualifications of installation personnel

The installation personnel must have the following qualifications:

- Successful completion of Webasto training
- Corresponding qualification for working on technical systems

#### Regulations and legal requirements

The regulations from the heater's general installation and operating instructions must be observed.

#### 3.3.1 Safety information on installation

##### Danger posed by live parts

- ▶ Prior to installation, disconnect the vehicle from the voltage supply.
- ▶ Make sure the electrical system is earthed correctly.
- ▶ Always comply with legal requirements.
- ▶ Observe data on type label.

##### Danger of fire and leaking toxic gases due to improper installation

- ▶ Vehicle parts in the vicinity of the heater must be protected against excessive heating by the following measures:
  - ⇒ Maintain minimum safety distances.
  - ⇒ Ensure adequate ventilation.
  - ⇒ Use fire-resistant materials or heat shields.

##### Danger due to sharp edges

- Lacerations
- Short circuit due to electrical wire damage
- ▶ Fit protectors on sharp edges.

## 3.4 Using this document

Before installing and operating the heater, read this installation documentation, the installation instructions of the heater, the operating instructions and supplementary sheets provided.

### 3.4.1 Explanatory Notes on the Document

There is an identification mark near the respective work step to allow you to quickly allocate the other applicable documents to the Webasto components to be installed:

Generally valid Webasto documentation	
Vehicle-specific installation documentation	
Vehicle-specific installation documentation of the cold start kit	
Webasto Comfort A/C control	
Webasto Standard A/C control	
Tank extracting device (e.g. FuelFix)	
Exhaust end fastener (EFIX)	
Combustion air intake silencer	
Spacer bracket (ASH)	

### 3.4.2 Use of symbols



#### DANGER

Type and source of the risk

Consequences: Failure to follow the instructions can result in death

► Actions to protect yourself against risks.



#### WARNING

Type and source of the risk

Consequences: Failure to follow the instructions can lead to serious or even fatal injuries

► Actions to protect yourself against risks.



#### CAUTION

Type and source of the risk

Consequences: Failure to follow the instructions can lead to minor injuries

► Actions to protect yourself against risks.



Type and source of the risk

Consequences: Failure to follow the instructions can lead to material damage

► Actions to protect yourself against risks.



Reference to the vehicle manufacturer's specific documents.



Note on a special technical feature

### 3.4.3 Work step identification marks

The ongoing work step is indicated on the outside top corner of the page:

Mechanical system	Electrical system	High-voltage	Coolant
Combustion air	Fuel	Exhaust	Software

### 3.4.4 Orientation aid

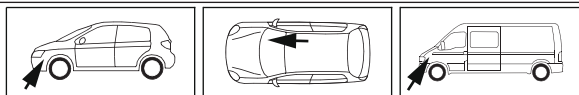

The arrow indicates the position on the vehicle and the viewing angle

### 3.4.5 Use of highlighting

Highlight	Explanation
✓	Action
►	Necessary action
⇒	Result of an action
<b>1</b> / <b>12</b> / <b>a1</b>	Position numbers for the image descriptions
<b>①</b> / <b>⑫</b> / <b>Ⓐ</b>	Position numbers for the image descriptions for electrical wires and components as well as coolant hose sections

## 4 Technical Information

### Dimension specifications

- All dimensions specified in mm
- Perforated brackets and mounting angles are shown to scale
- Observe data regarding scale on the templates

### Tightening torque specifications

- Tightening torque values of 5x13 heater bolts and 5x11 heater stud bolts = 8Nm
- Tightening torque values of 5x15 retaining plate of water connection piece bolts = 7Nm
- 5x12 bolt tightening torque of 2-part heater bracket = 6Nm
- Tighten other bolt connections in accordance with manufacturer's instructions or in accordance with state-of-the-art-technology

### Temperature specification for heat shrink plastic tubings

- Fabric heat shrink tubing: shrink temperature max. 230°C
- Standard heat shrink plastic tubing: shrink temperature max. 300°C

### Necessary special tools

- Hose clamp pliers for auto-tightening hose clamps
- Hose clamp pliers for Clic hose clamps of type W
- Hose clamping pliers
- Hose cutter
- Automatic wire stripper 0.2 - 6 mm<sup>2</sup>
- Crimping pliers for cable lugs 0.5 – 10 mm<sup>2</sup>
- Crimping pliers for male connector 0.14 – 6 mm<sup>2</sup>
- Crimping pliers for connector 0.25 – 6 mm<sup>2</sup>
- Torque wrench for 2.0 - 10 Nm
- Deep-hole marker
- Metric thread-setter kit
- Webasto Thermo Test Diagnosis with current software

## 5 Preparations

### 5.1 Vehicle preparation



Further information can be found in the vehicle manufacturer's technical documentation.

Vehicle area	Components to be removed	Other applicable documents
General	<ul style="list-style-type: none"> <li>▶ Open the fuel tank cap</li> <li>▶ Ventilate the fuel tank</li> <li>▶ Close the fuel tank cap again</li> <li>▶ Depressurise the cooling system</li> </ul>	
Engine compartment and body	<ul style="list-style-type: none"> <li>▶ Engine design cover</li> <li>▶ Complete air filter</li> <li>▶ Disconnect the battery</li> <li>▶ Battery complete with battery carrier</li> <li>▶ Engine compartment relay and fuse box cover</li> <li>▶ Front wheel on the front passenger's side</li> <li>▶ Wheel well trim on the front passenger's side</li> <li>▶ Engine underride protection</li> <li>▶ Underbody underride protection on the front passenger's side</li> </ul>	
Passenger compartment	<ul style="list-style-type: none"> <li>▶ Side instrument panel trim on the front passenger's side</li> <li>▶ Footwell trim on the front passenger's side</li> <li>▶ Glove box</li> <li>▶ Lower instrument panel trim in the middle</li> <li>▶ Rear bench seat</li> <li>▶ Open the tank fitting service lid on the front passenger's side</li> </ul>	

### 5.2 Heater preparation

Engine compartment	<ul style="list-style-type: none"> <li>▶ Remove years that do not apply from the type and duplicate label</li> <li>▶ Attach the duplicate label (type label) in the appropriate place in the engine compartment</li> </ul>	
--------------------	--	--



## 6 Installation overview

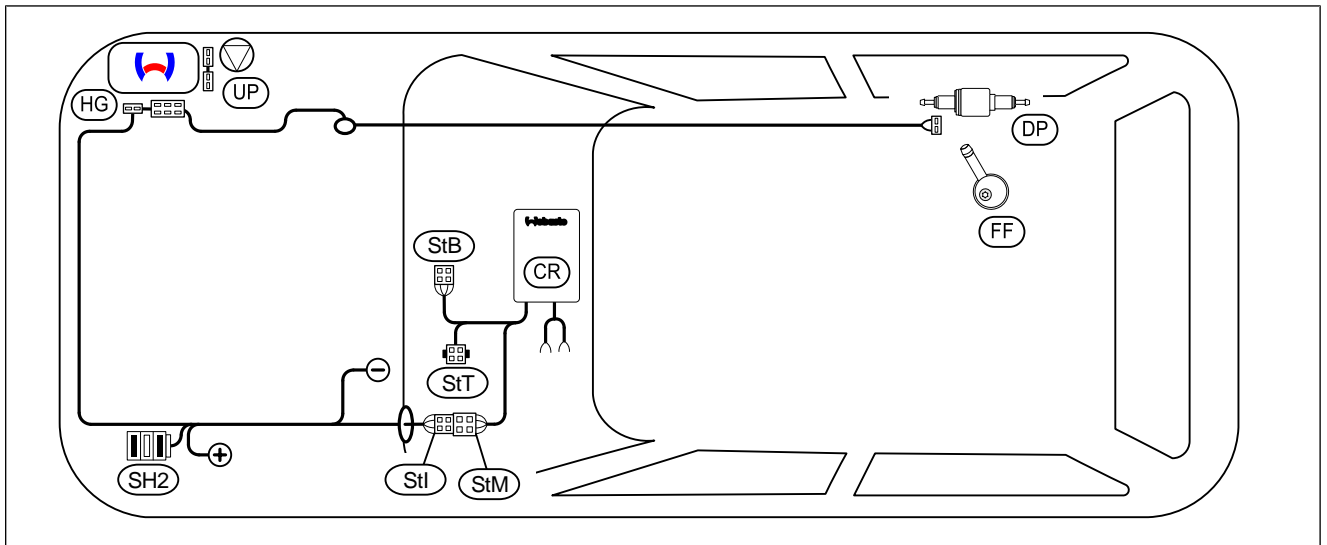
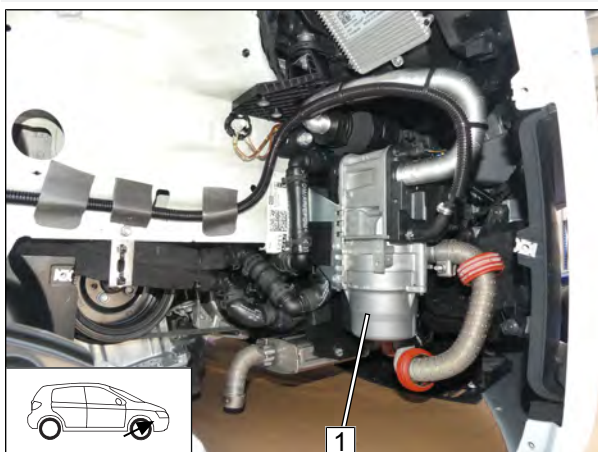

Fig. 1

### Legend to installation overview

Abbreviation	Component
CR	Cronus (passenger compartment control unit)
DP	Fuel pump
FF	FuelFix
HG	Heater assembly
SH2	Engine compartment fuse holder for F1/F2/F3
StB	Female plug for control element wiring harness
StI	Female plug for passenger compartment wiring harness
StM	Male plug for engine compartment wiring harness
StT	Male plug for push button wiring harness
UP	Coolant pump

### Heater assembly installation location



1 Heater assembly

Fig. 2



## 7 Electrical system of engine compartment

### Removing cover

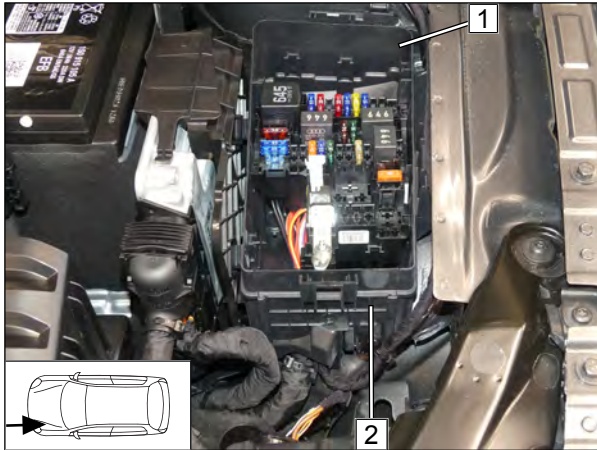

Fig. 3

- ▶ Remove front cover **2** of engine compartment fuse and relay box **1**.

### Copying hole pattern, drilling hole

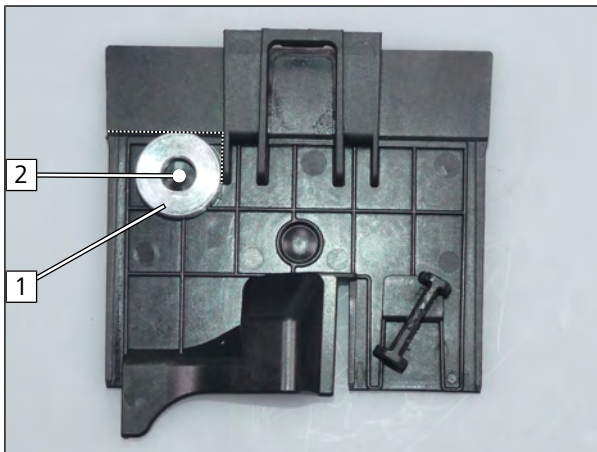

Fig. 4

- ▶ Position 10mm spacer **1** on front cover, copy hole pattern **2** and drill  $\text{Ø}6$  hole.

### Premounting retaining plate of SH2

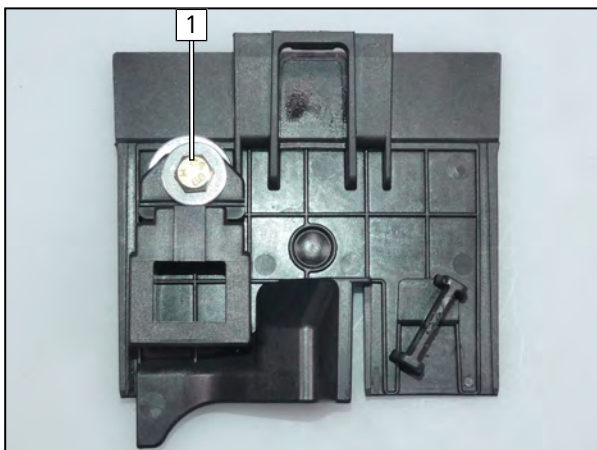

Fig. 5

- 1** M5x20 bolt, large diameter washer, SH2 retaining plate, spacer (5), front cover, retaining plate, nut



## Preparing wiring harness

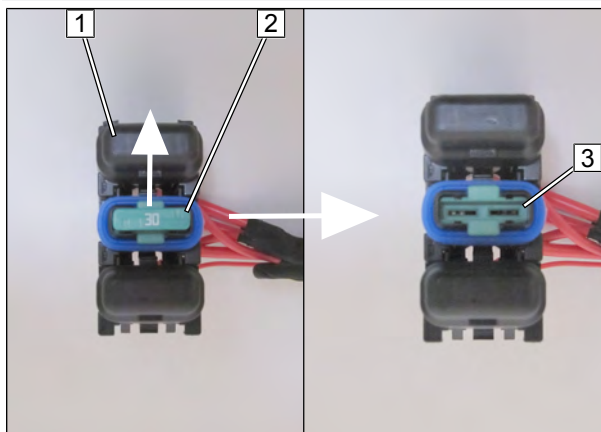

Fig. 6

Remove and discard 30A fuse **2** from SH2 **1**.

**3** Fuse removed

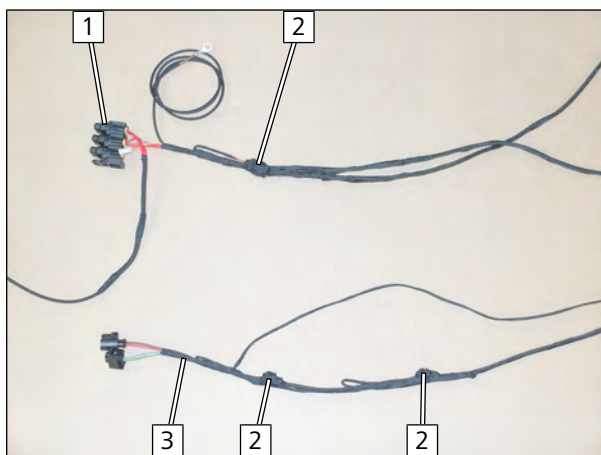

Fig. 7

Tie back connector **2** using insulating tape.

**1** SH2

**3** Heater wiring harness

## Mounting cover and SH2

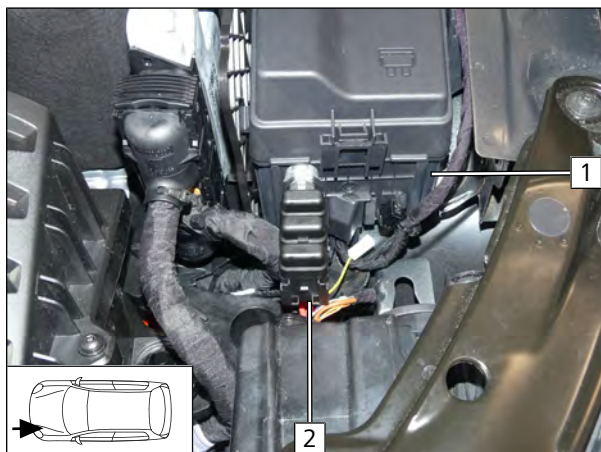

Fig. 8

**1** Front cover

**2** SH2 with F1, F2 (empty) and F3



## Routing wiring harnesses

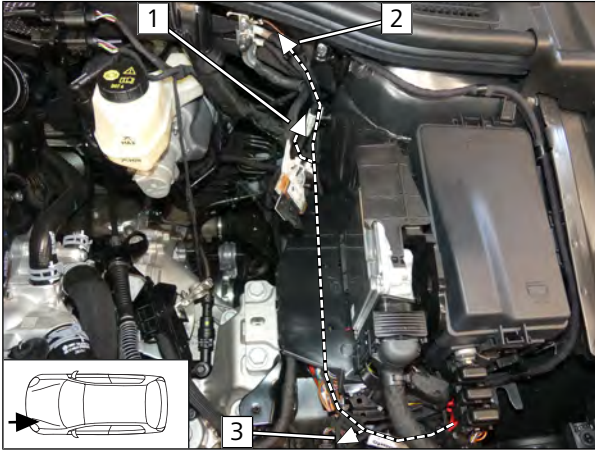

Fig. 9

- 1 Passenger compartment wiring harness
- 2 Earth wire
- 3 Heater wiring harness

## Earth wire connection

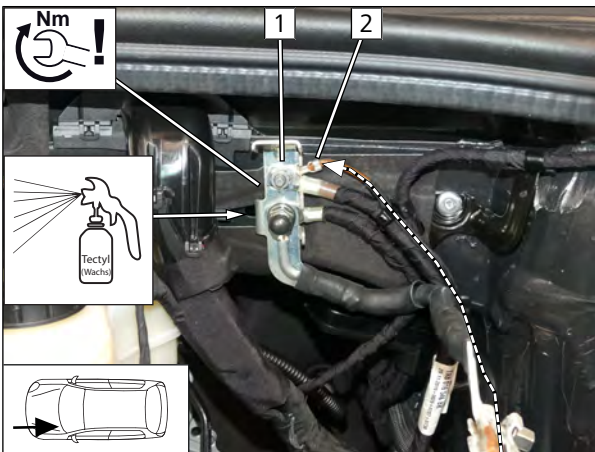

Fig. 10



### DANGER

Observe tightening torque

- 1 Original vehicle earth point
- 2 Earth wire

## Passenger compartment wiring harness pass through

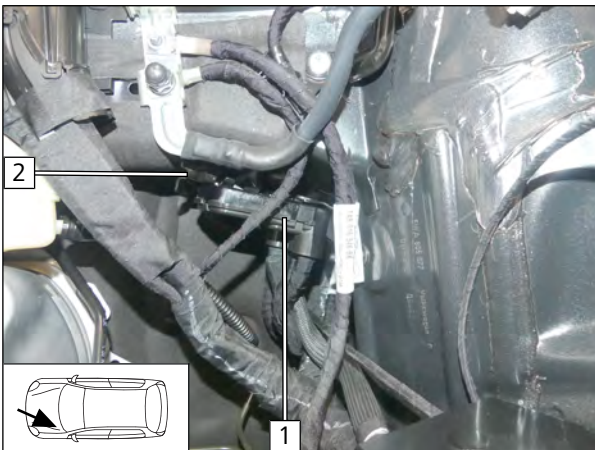

Fig. 11

- Remove positive distributor 1 from bracket 2.



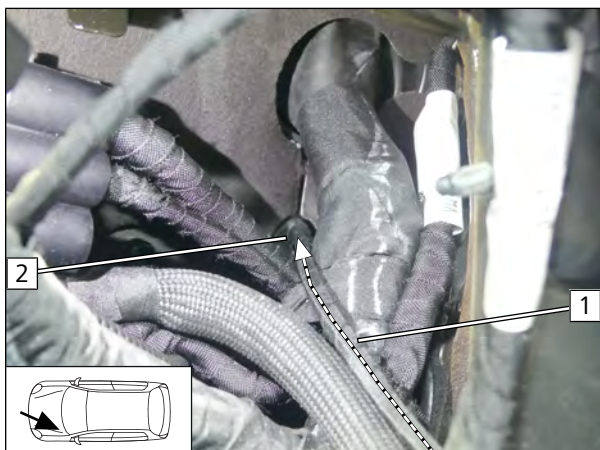

Fig. 12



To prevent water seeping into the passenger compartment, the wiring harness must be routed upwards to the protective rubber plug and this plug must then be sealed with a suitable sealing compound.

- 1 Passenger compartment wiring harness
- 2 Pass through in protective rubber plug (open using suitable means)

### Heater wiring harness routing

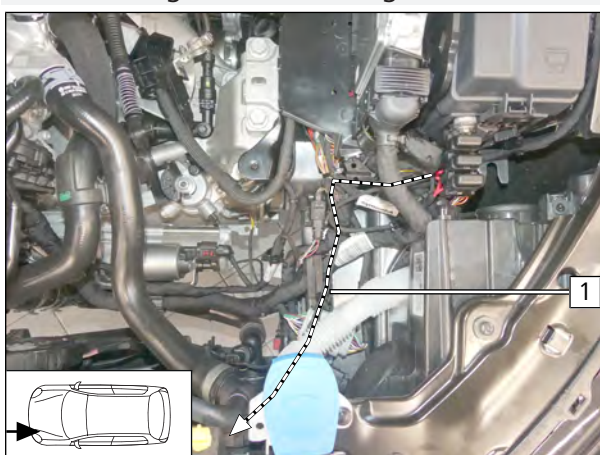

Fig. 13

- 1 Heater wiring harness

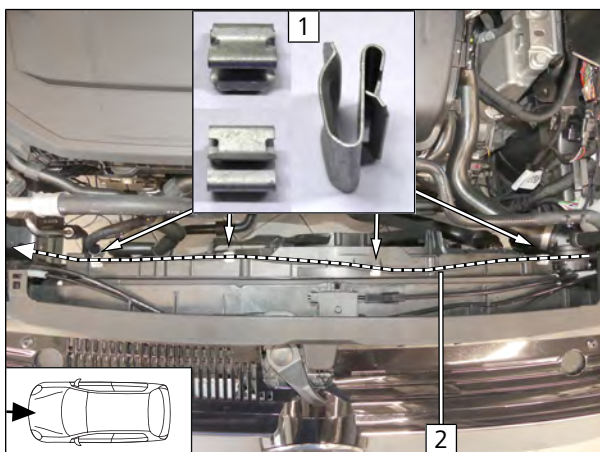

Fig. 14

- 1 Edge clip
- 2 Heater wiring harness

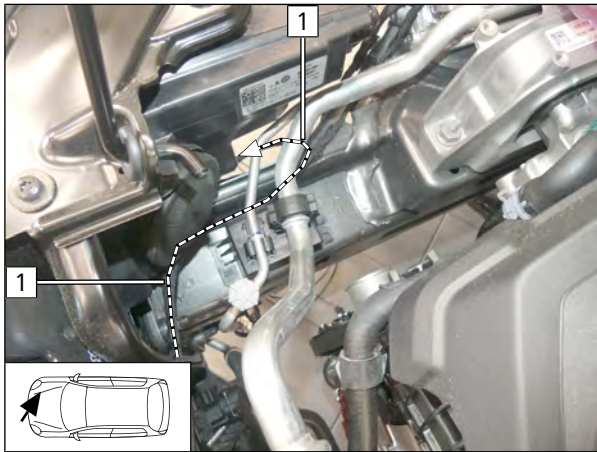

Fig. 15

- 1 Heater wiring harness

### Positive wire connection

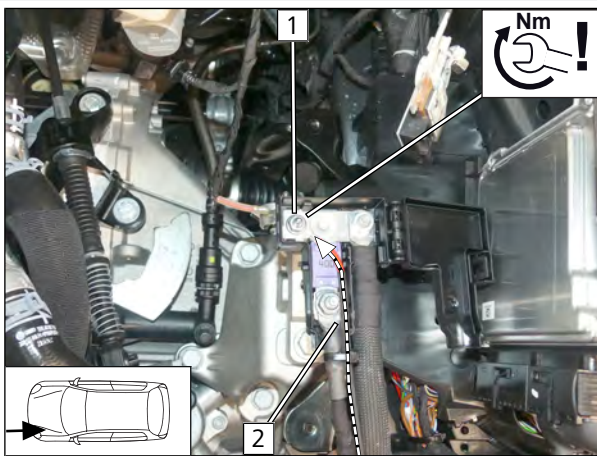

Fig. 16



### DANGER

Observe tightening torque

- 1 Original vehicle positive point
- 2 Positive wire



## 8 Mechanical system

### 8.1 Installation location preparation

#### Loosening original vehicle wiring harness

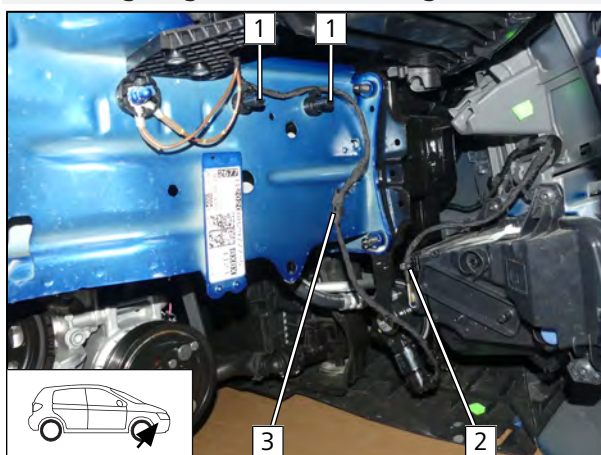

Fig. 17

- ▶ Remove and discard original vehicle wiring harness bracket **1**.
- ▶ Remove and discard original vehicle cable tie **2**
- ▶ Detach original vehicle wiring harness bracket **3**

#### Routing original vehicle wiring harness again

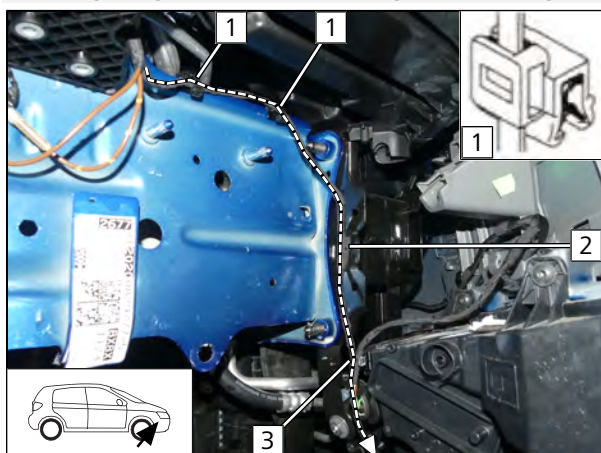

Fig. 18

- ▶ Attach original vehicle wiring harness bracket **2** again at new position.
- ▶ Edge clip cable tie **1**
- ▶ Cable tie **3**

#### Adapting original vehicle tab

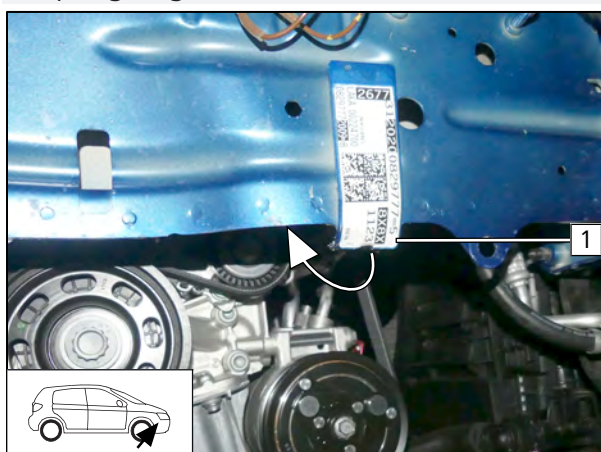

Fig. 19

- ▶ Bend original vehicle tab **1** by 90° as shown.





## Routing and fastening heater wiring harness

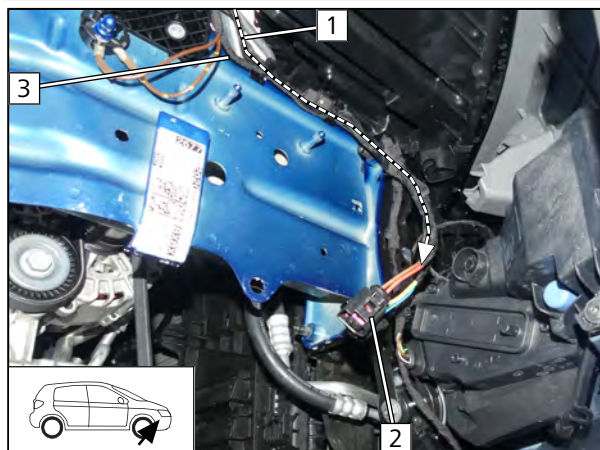

Fig. 20

- 1 Heater wiring harness
- 2 HG connector
- 3 Original vehicle wiring harness

## Mounting spacer

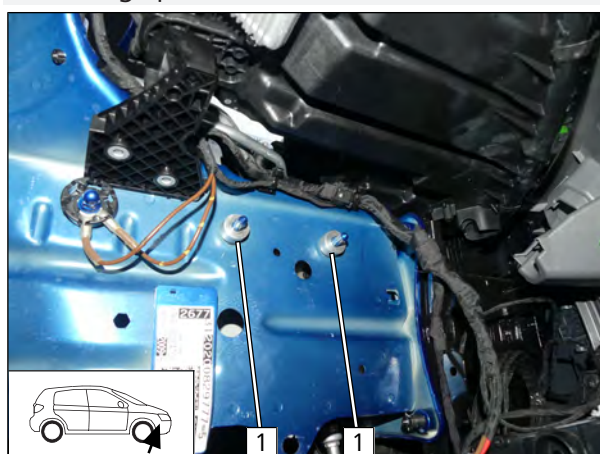

Fig. 21

- 1 10 spacer

## 8.2 Premounting heater assembly

### Copying hole pattern

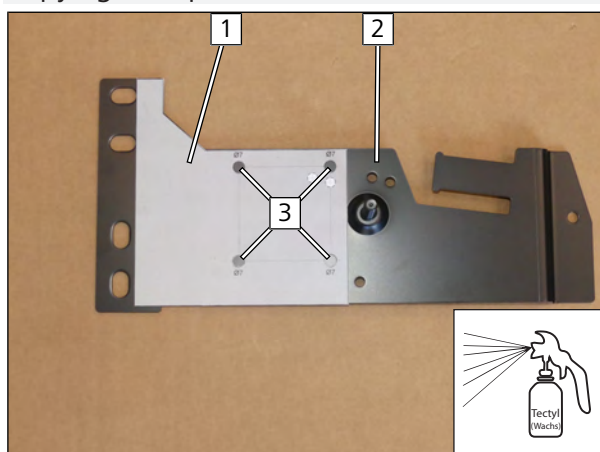

Fig. 22

- ▶ Cut out provided template 1.
- ▶ Position template 1 on bracket 2 as shown and copy hole pattern 3.





## Drilling hole

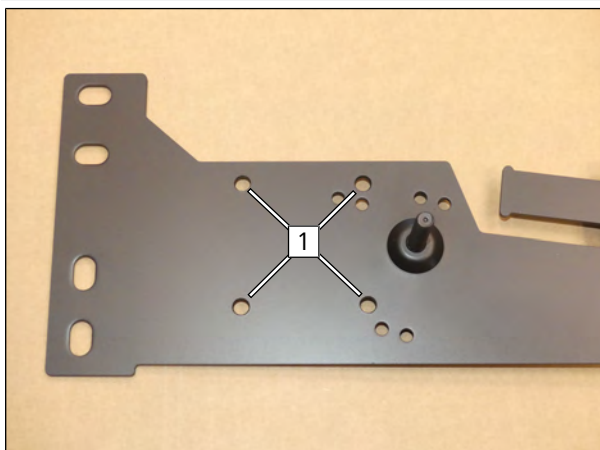

**1** Ø7 hole

Fig. 23

## Premounting HG bracket

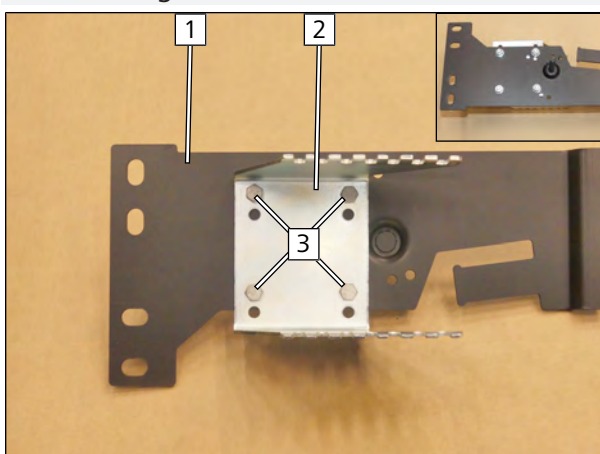

- 1** Bracket part 1
- 2** Bracket part 2
- 3** M6x12 bolt, flanged nut

Fig. 24

## Cutting exhaust pipe to length

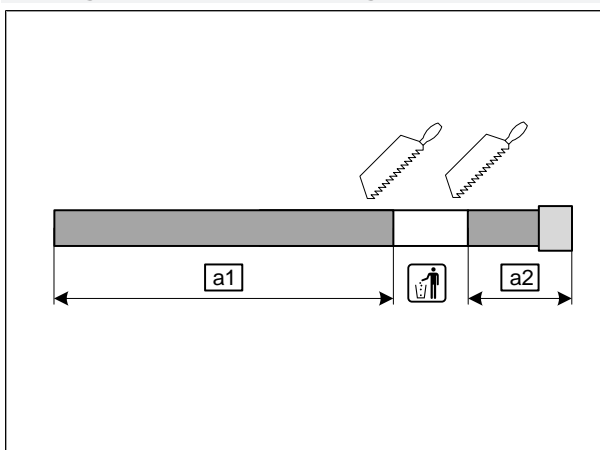

**a1** 450

**a2** 100

Fig. 25

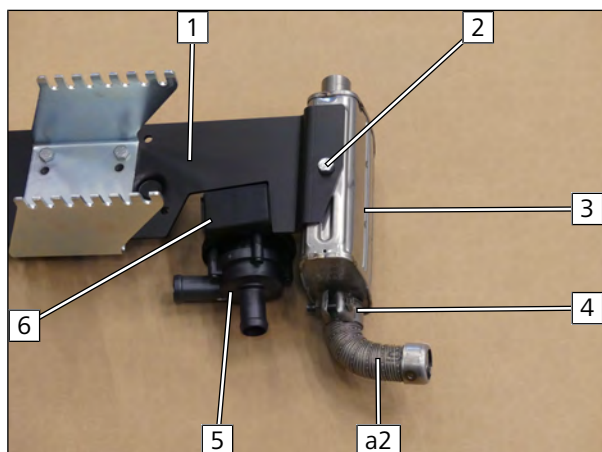

Fig. 26

- 1 Bracket part 1
- 2 M6x16 bolt, spring lockwasher
- 3 Exhaust silencer
- 4 Hose clamp
- 5 Coolant pump
- 6 Coolant pump mount

### Cutting hoses to length

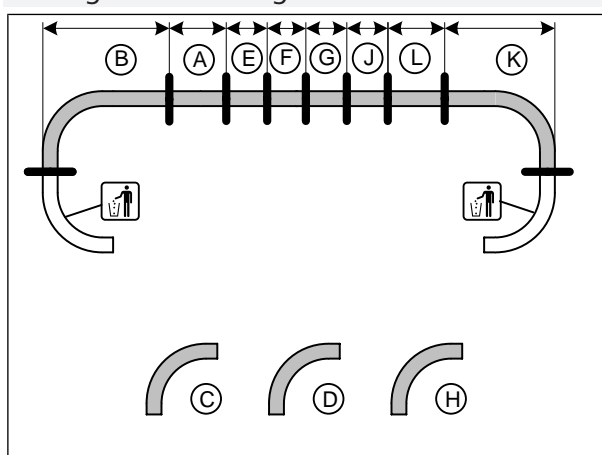

Fig. 27

### Mounting hose C

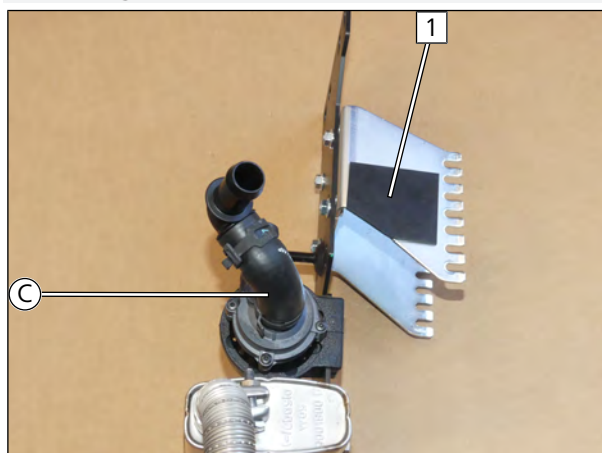

Fig. 28

- 1 Rub protection



## Premounting M5x13 self-tapping bolts

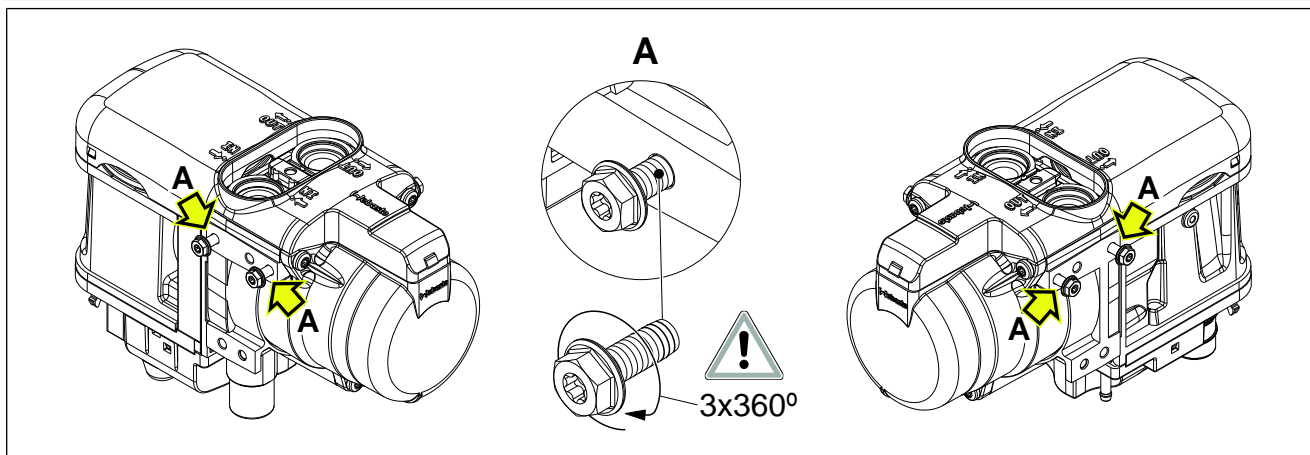

Fig. 29

## Mounting, aligning and fastening with 7Nm water connection piece with sealing ring and retaining plate

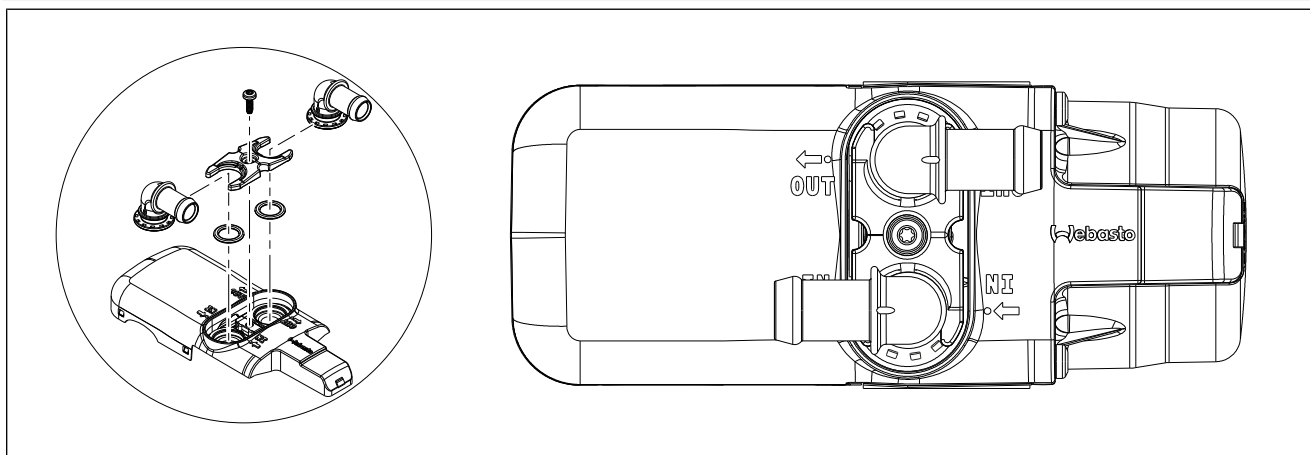
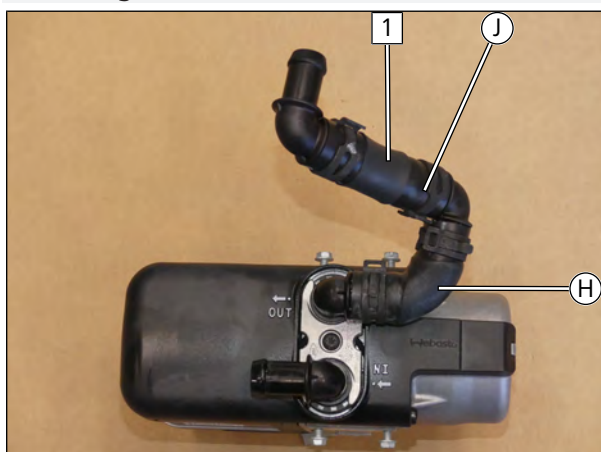

Fig. 30

## Mounting hoses (H) and (J)



- ▶ 1. Slide on heat shrink plastic tubing **1** as shown and cut to length
- ▶ 2. Shrink, use at most 300 °C

Fig. 31



## Mounting hoses **D**, **E**, **F**, and **G**

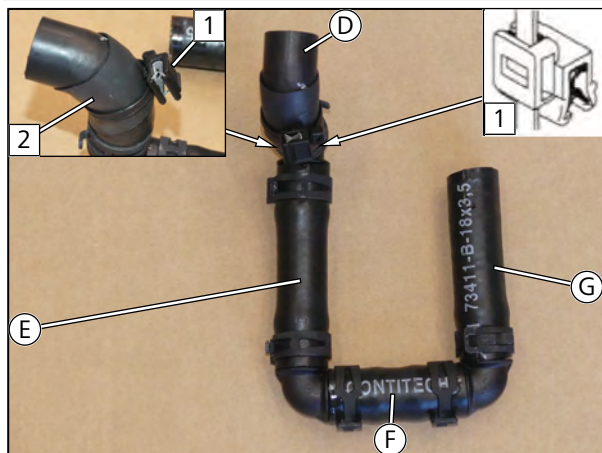

Fig. 32



- ▶ 1. Slide on heat shrink plastic tubing **2** as shown and cut to length
- ▶ 2. Shrink, use at most 300 °C

**1** Edge clip cable tie

## Mounting hose group

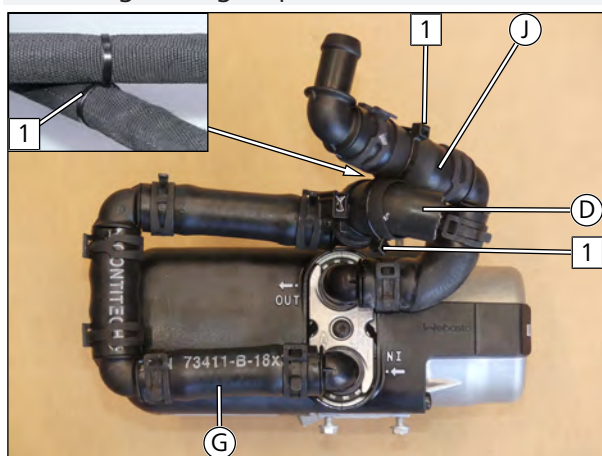

Fig. 33

- ▶ Loop cable ties **1** around hoses **D** and **J** and attach them together.

## Premounting fuel line

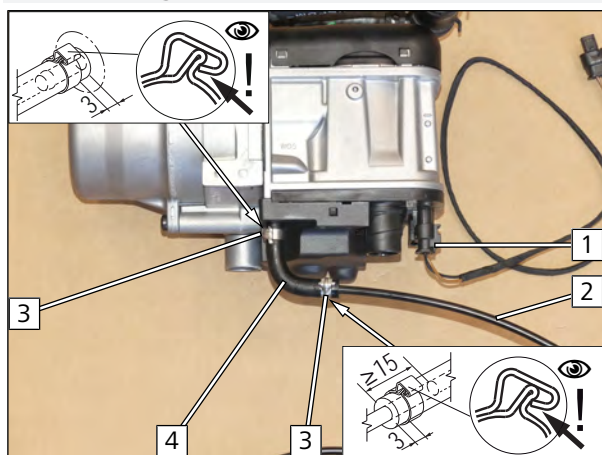

Fig. 34

- 1** Coolant pump wiring harness connector
- 2** Fuel line
- 3** Ø10 clamp
- 4** 90° moulded hose



## Mounting heater

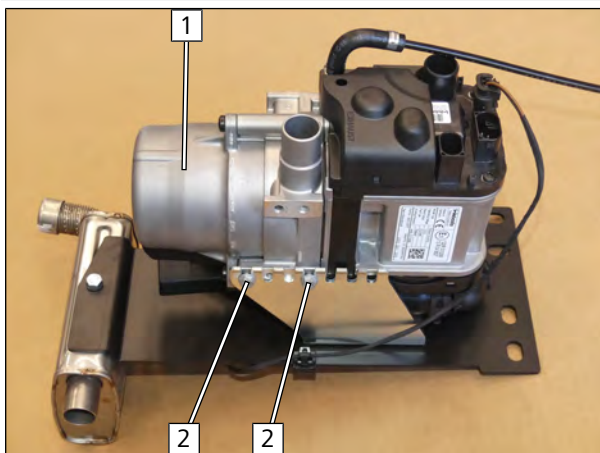

Fig. 35

- 1 Premounted HG
- 2 Tighten premounted bolts

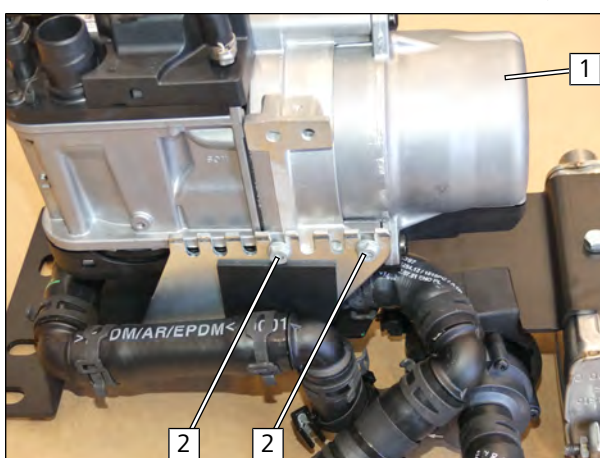

Fig. 36

- 1 Premounted HG
- 2 Tighten premounted bolts

## Mounting coolant pump connector

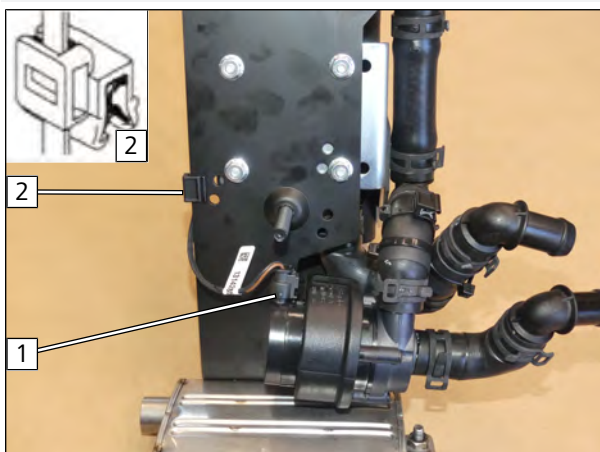

Fig. 37

- 1 Coolant pump wiring harness connector
- 2 Edge clip cable tie





## Mounting exhaust pipe **a1**

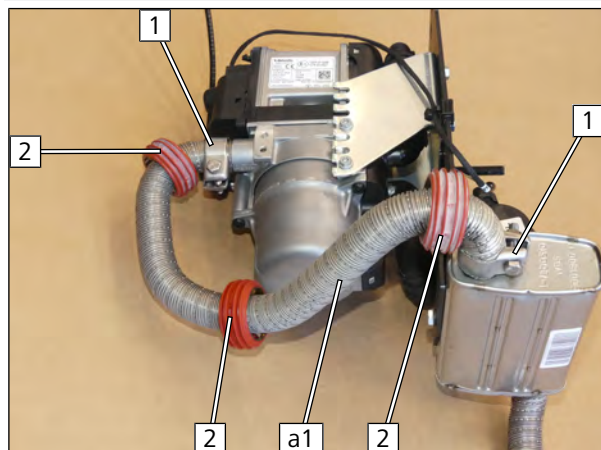

Fig. 38

- 1 Hose clamp
- 2 Spacer bracket

## 8.3 Heater assembly installation

### Mounting heater

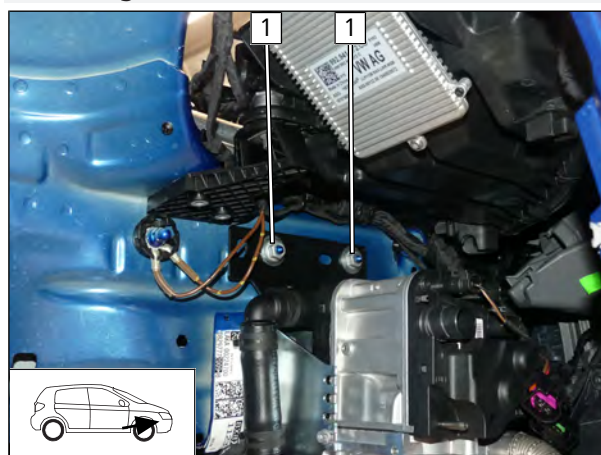

Fig. 39

- 1 Mount flanged nut loosely

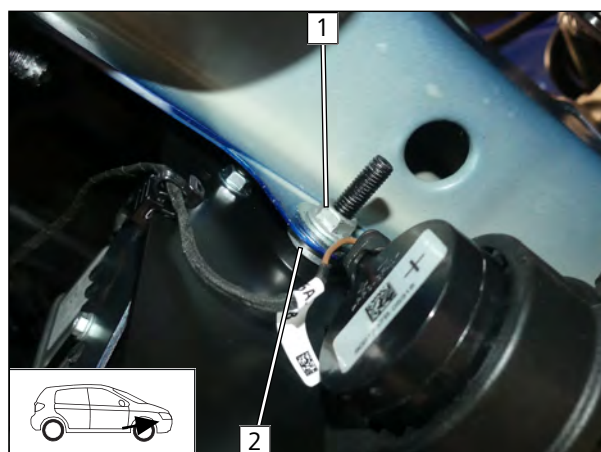

Fig. 40

- 1 Mount heater bracket stud bolt, spacer (5), original vehicle tab, large diameter washer, flanged nut loosely
- 2 5 spacer



## Checking distance

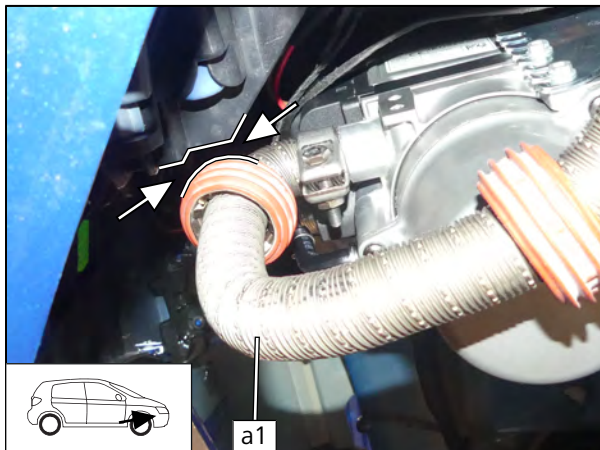

Fig. 41



Danger of damage to components

- ▶ Ensure sufficient distance between exhaust pipe **a1** and neighbouring components, correct if necessary.

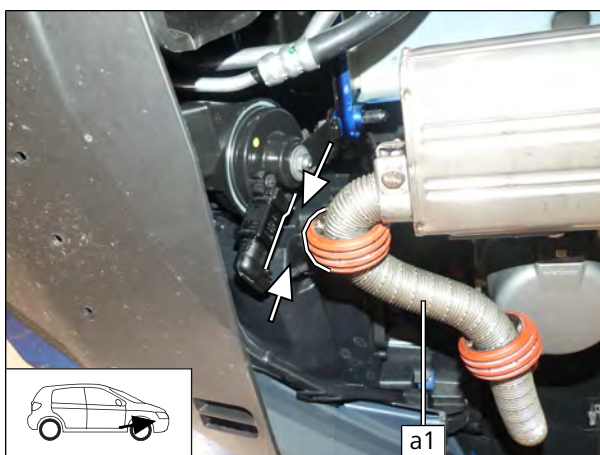

Fig. 42



Danger of damage to components

- ▶ Ensure sufficient distance between exhaust pipe **a1** and neighbouring components, correct if necessary.



Tighten all the screw connections of the heater assembly.

## Mounting heater connector

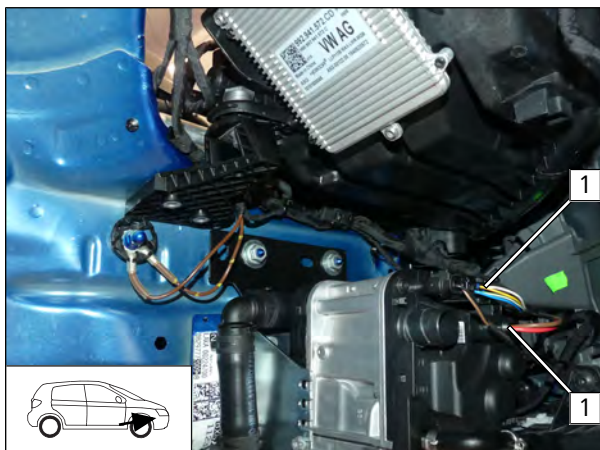

Fig. 43

- 1 HG connector



## 9 Combustion air

### Preparing edge clip cable tie [2x]

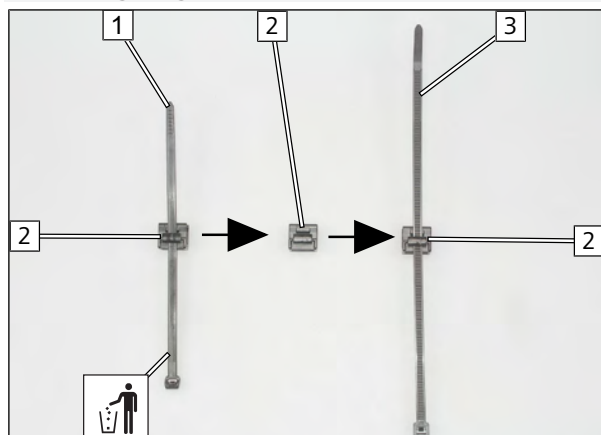

Fig. 44

- 1 Remove original cable tie
- 2 Clip
- 3 Reinstall cable tie

### Mounting edge clip cable tie [2x]

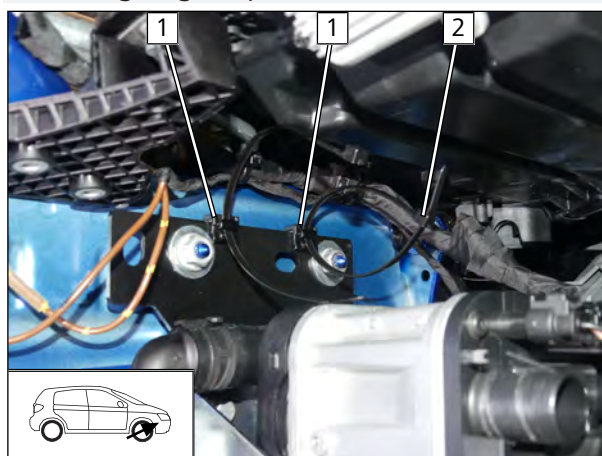

Fig. 45

- Position edge clip cable tie **1** as shown. Close cable tie **2** as shown.

### Preparing combustion air intake silencer

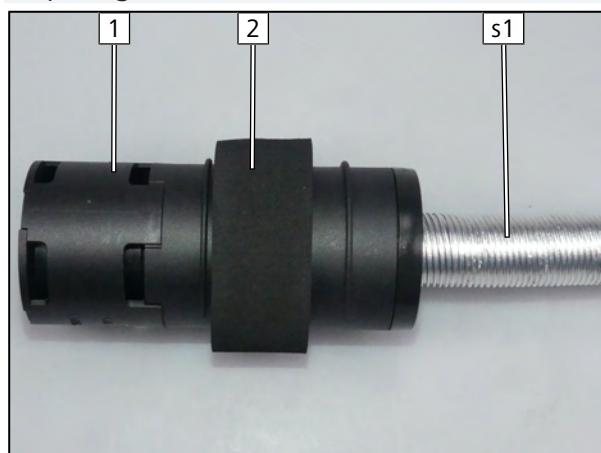

Fig. 46



Observe the installation instructions of the combustion air intake silencer.

- 1 Combustion air intake silencer
- 2 Foam ring
- s1 Combustion air intake line





## Mounting combustion air intake silencer

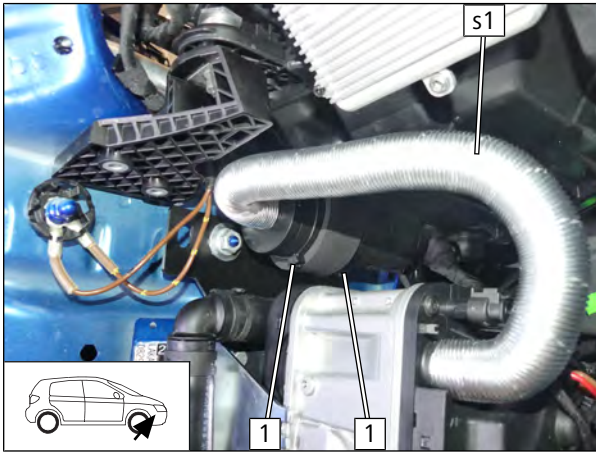

- 1 Close cable tie

Fig. 47



## 10 Fuel



### DANGER

**Risk of fire and explosion due to leaking fuel and escaping fuel vapours.**

The incorrect installation of the fuel extractor can cause damage and fire.

- ▶ Avoid electrostatic discharges and open fire
- ▶ When working on the fuel system, ensure sufficient ventilation and bleeding
- ▶ Open the fuel tank cap of the vehicle
- ▶ Ventilate the fuel tank
- ▶ Re-close the tank lock
- ▶ Catch any fuel running off with an appropriate container



### Danger of damage to components

- ▶ Install fuel line and fuel pump wiring harness so that they are protected against stone impact
- ▶ Provide rub protection for fuel line and wiring harness in areas where there are sharp edges

### Dismantling fuel pump connector X7

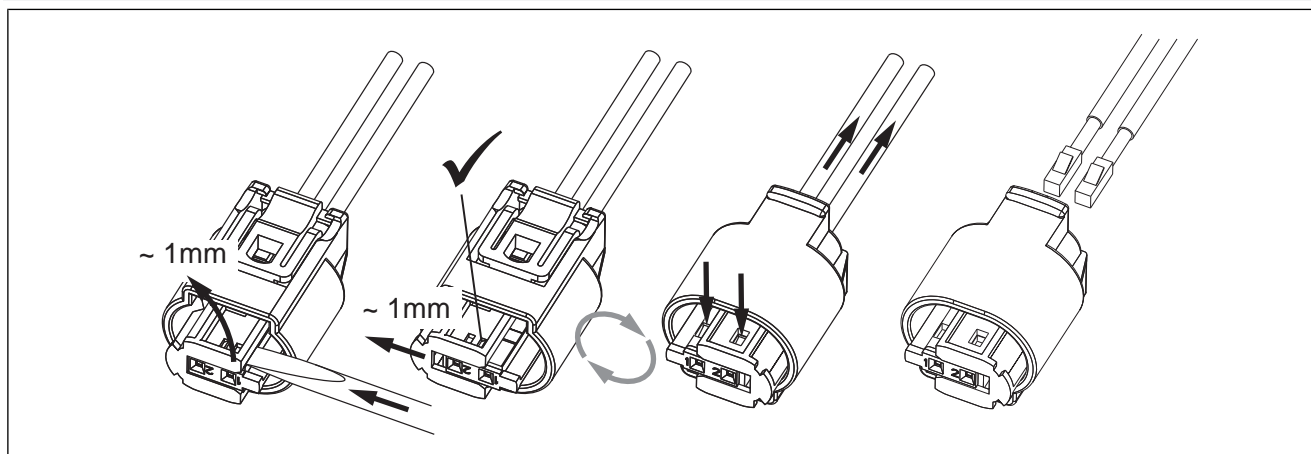

Fig. 48

### 10.1 Routing fuel line

#### Cutting corrugated tube to length

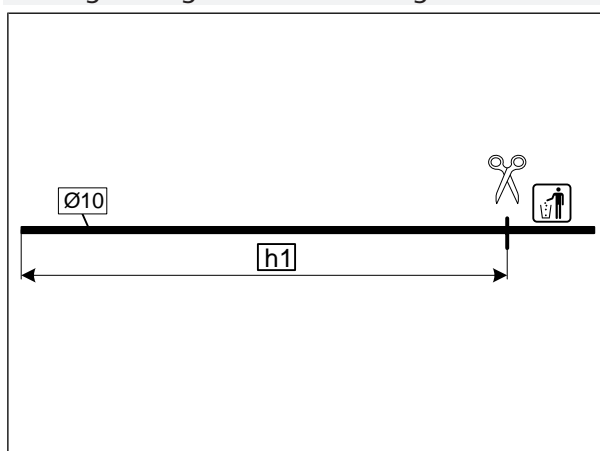

Fig. 49

**h1** 900



## Routing fuel line in wheel well

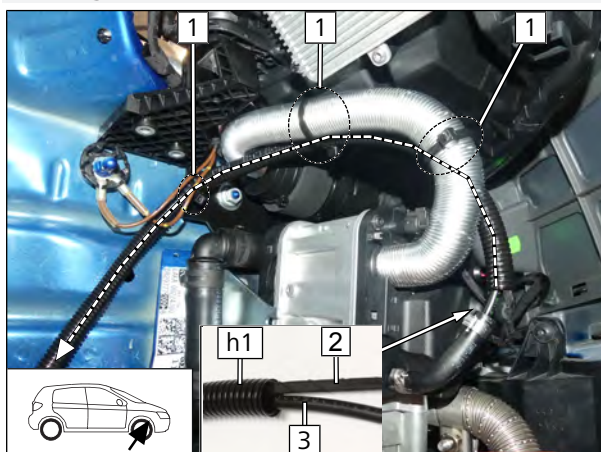

Fig. 50

► Draw fuel line **3** and fuel pump wiring harness **2** into corrugated tube **h1**.

**1** Cable tie

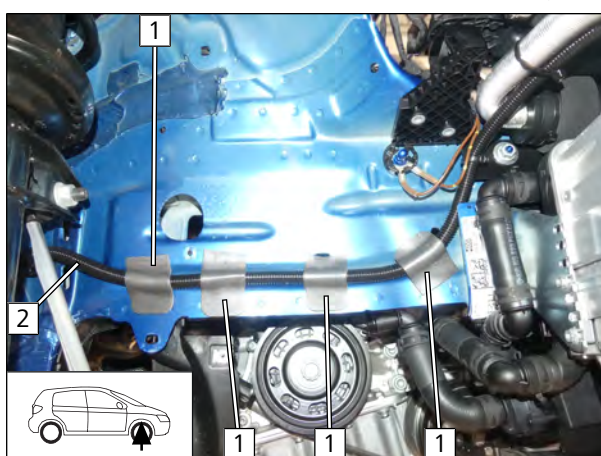

Fig. 51

**1** Self-adhesive foam cut in half

**2** Fuel line and fuel pump wiring harness in corrugated tube **h1**

## Preparing pass through

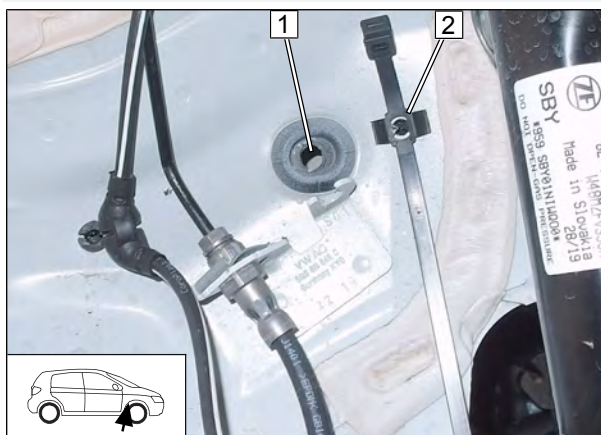

Fig. 52

► Pierce original vehicle pass through **1** in the middle as shown.

**2** Eyelet cable tie in original vehicle hole



## Routing fuel line to underbody

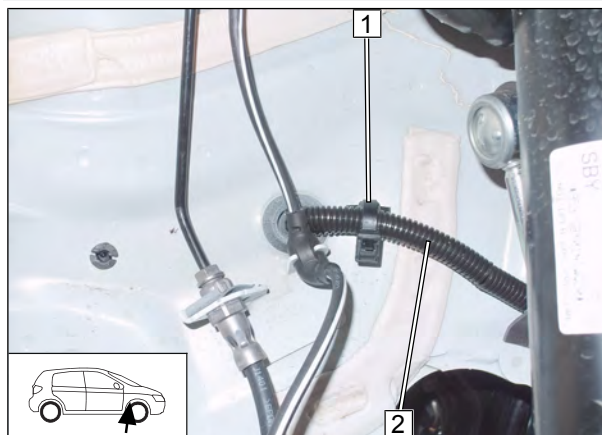

Fig. 53

- 1 Close eyelet cable tie
- 2 Fuel line and fuel pump wiring harness in corrugated tube **h1**

## Preparing fuel pump installation location

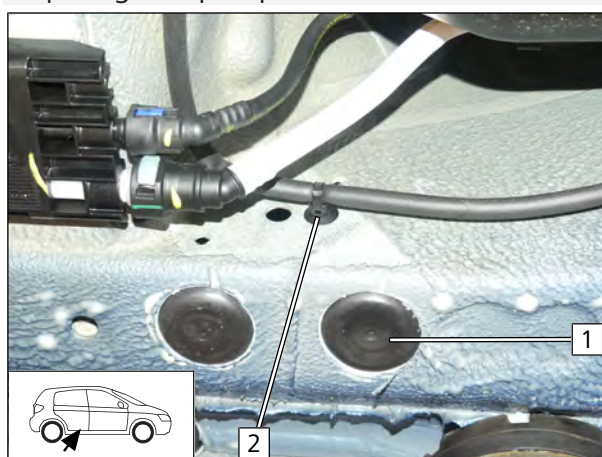

Fig. 54

- ▶ Remove clip-type cable tie **2** and plug **1**.

## Premounting bolts

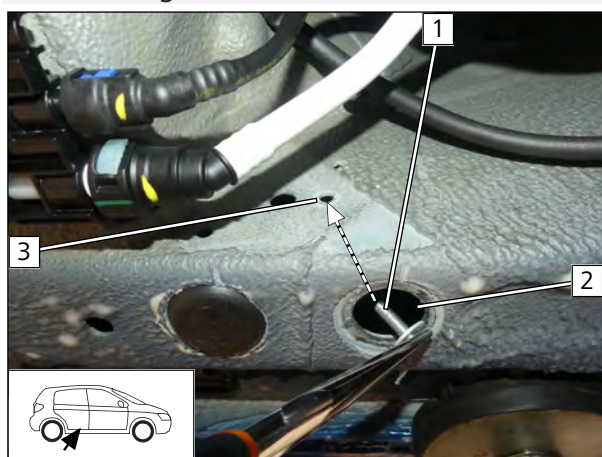

Fig. 55

- 1 M6x20 bolt, large diameter washer
- 2 Assembly opening
- 3 Original vehicle hole



Fig. 56

- 1 Lock washer

### Premounting fuel pump

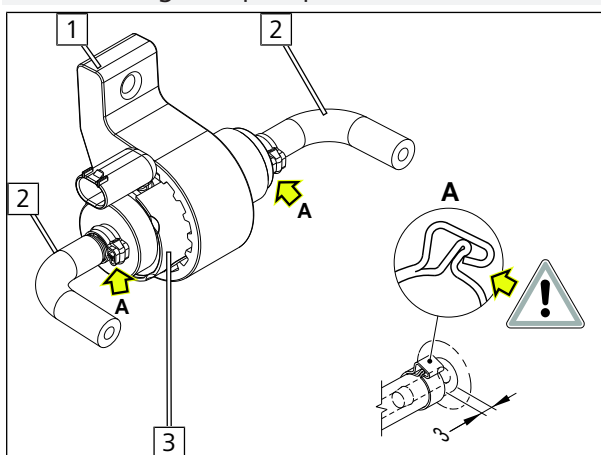

Fig. 57

The alignment of the fuel pump and fuel hoses will be carried out afterwards, during the installation.

- 1 Fuel pump mount
- 2 90° moulded hose, Ø10 clamp
- 3 Fuel pump

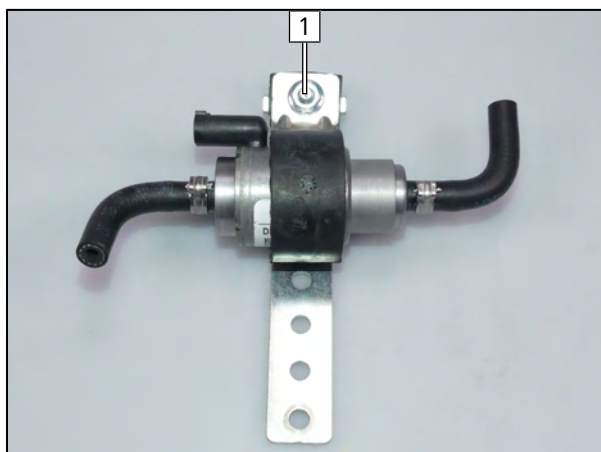

Fig. 58

- 1 M6x25 bolt, perforated bracket, fuel pump mount, support angle bracket, flanged nut





## Mounting fuel pump



Fig. 59

- 1 Sealing plug, mounted
- 2 Premounted fuel pump, premounted M6x20 bolt, flanged nut
- 3 Installing clip-type cable tie

## Assembling fuel pump connector X7

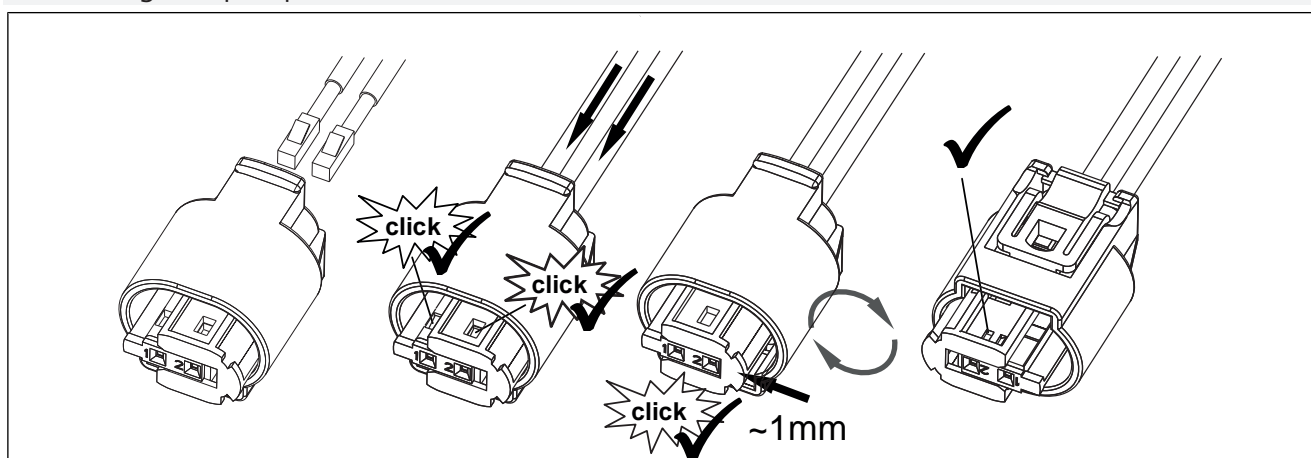

Fig. 60

## Connecting fuel pump

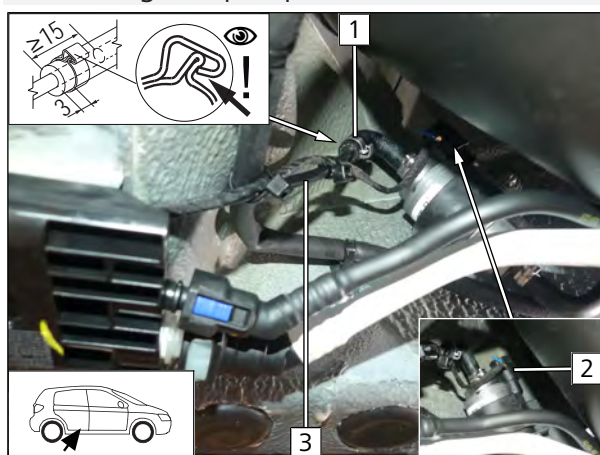
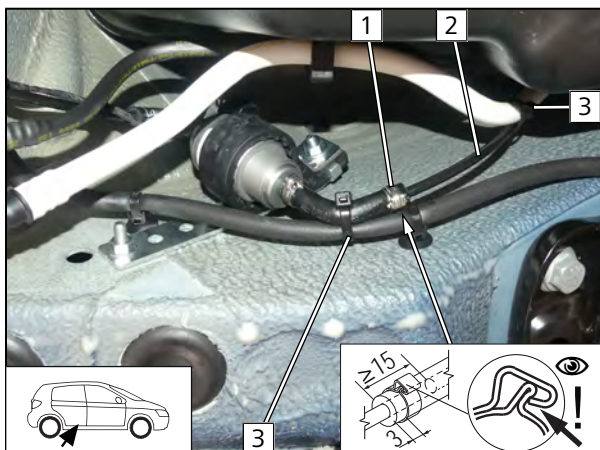

Fig. 61

- 1 Ø10 clamp
- 2 Fuel pump wiring harness, connector X7 mounted
- 3 Fuel line



- 1 Ø10 clamp
- 2 Fuel line
- 3 Cable tie

Fig. 62

## 10.2 Installing FuelFix

### Moving label

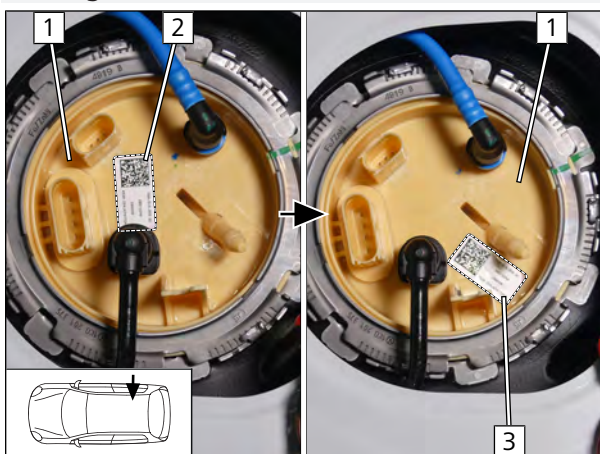

- 1 Tank fitting
- 2 Original position of label
- 3 New position of label

Fig. 63

### Work steps F1, F2

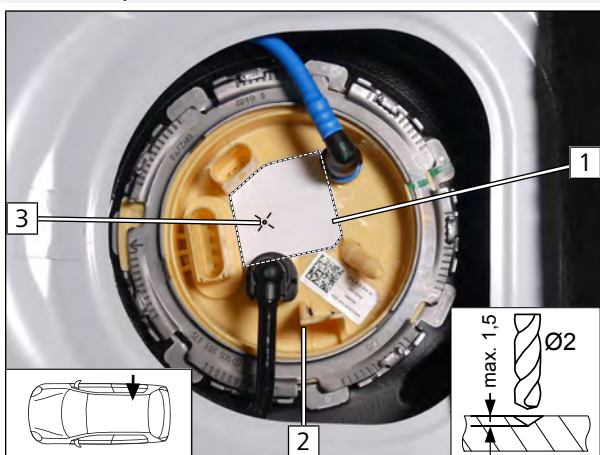

**F** Observe the installation instructions of the tank extracting device.

- ▶ Cut out provided template **1** and position as shown.
- ▶ Copy hole pattern **3** onto tank fitting **2**.
- ▶ Drill Ø2 centring hole at position **3** as shown.

Fig. 64



### Work step F3

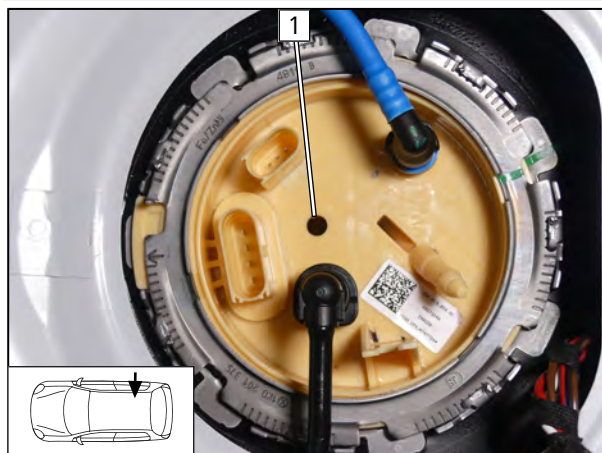

Fig. 65



### DANGER

Risk of fire and explosion due to leaking fuel and escaping fuel vapours.

- 1 Hole made with provided drill

### Work steps F4, F5

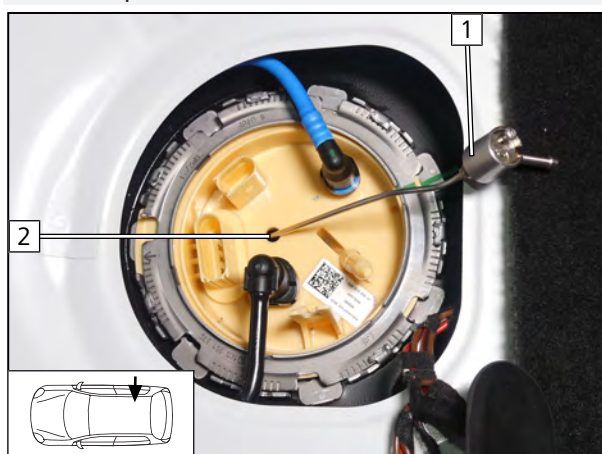

Fig. 66

- Bend FuelFix 2 according to template and cut to length. Insert in hole 1.

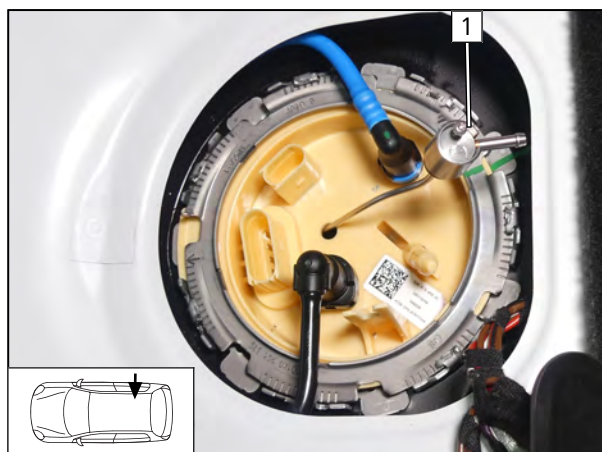

Fig. 67



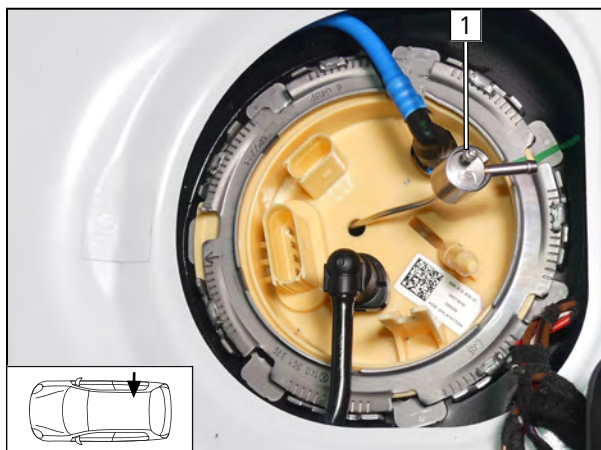

Fig. 68

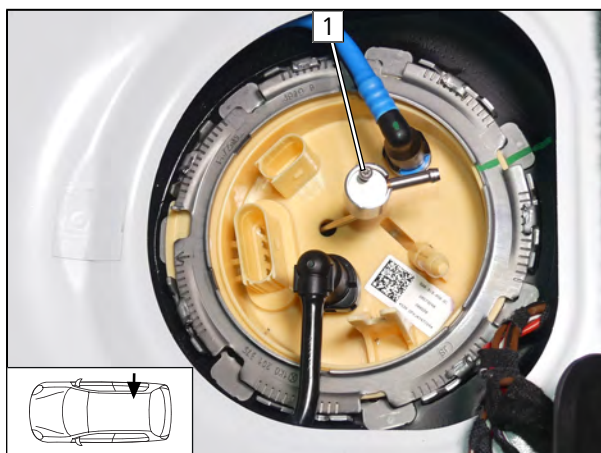

Fig. 69

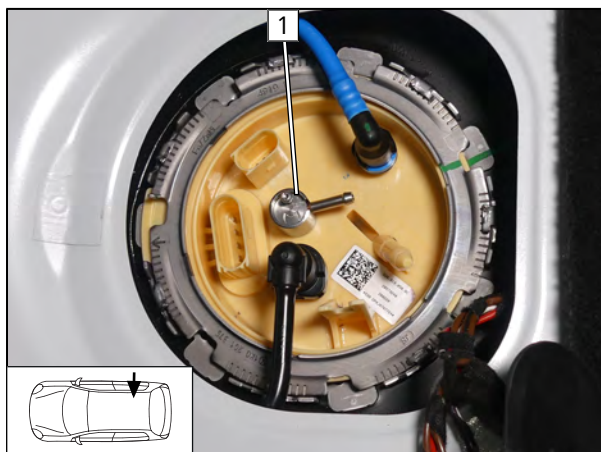
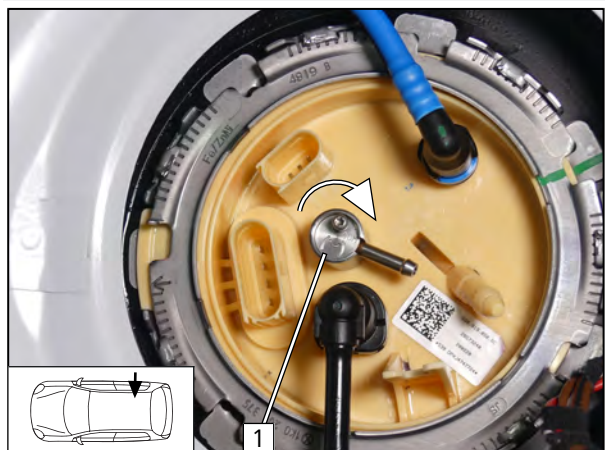

Fig. 70



### Work steps F5.3, F5.4



► Align FuelFix **1** as shown.

Fig. 71

### Preparing work step F6

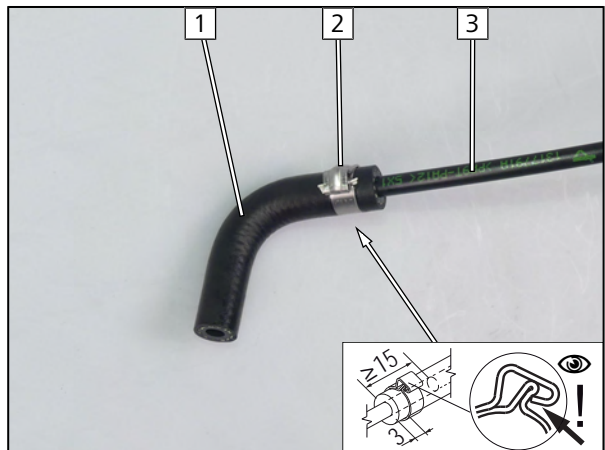

- 1** 90° moulded hose
- 2** Ø10 clamp
- 3** Fuel line

Fig. 72

### Work step F6

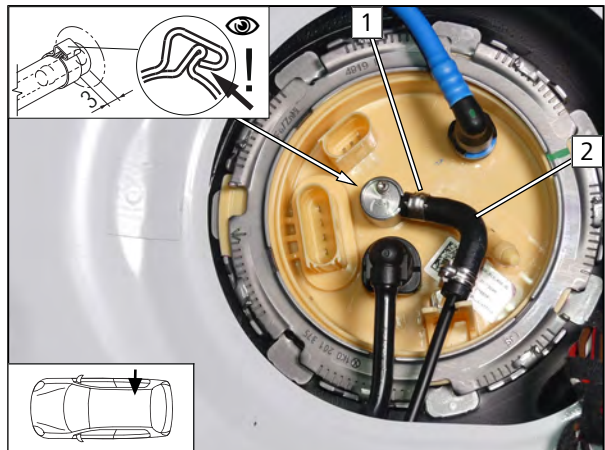

- 1** 10mm dia. clamp [2x]
- 2** Prepared moulded hose

Fig. 73



## Work step F7

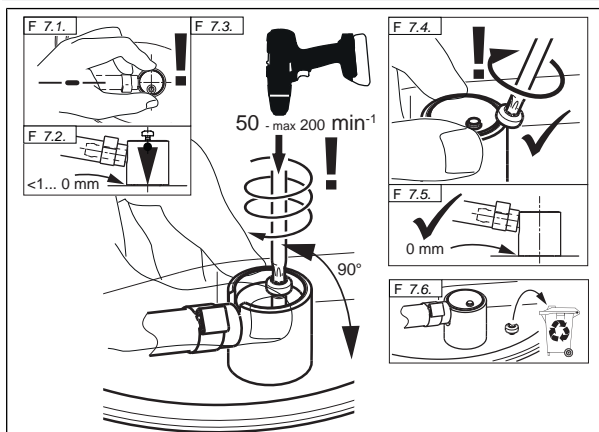

Fig. 74



## DANGER

Risk of fire and explosion due to leaking fuel and escaping fuel vapours.

## Work step F8

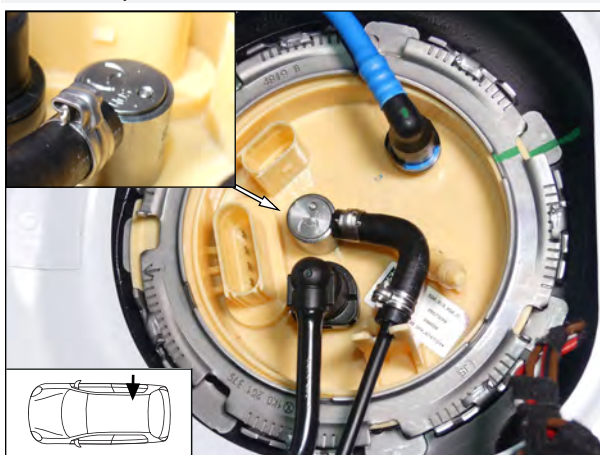

Fig. 75

## Securing fuel line

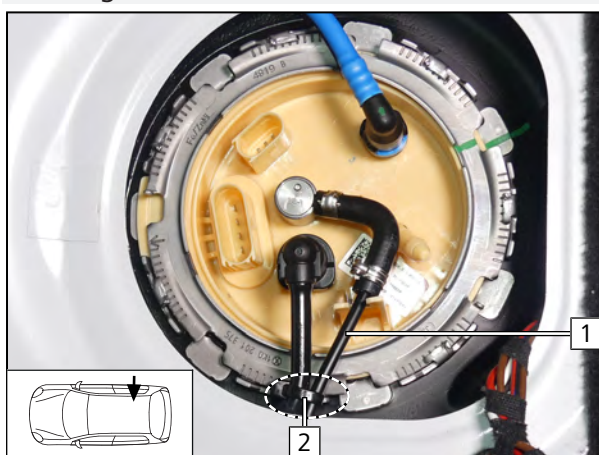

Fig. 76

► Secure fuel line **1** with cable tie **2** for tension relief.



## 11 Coolant

### 11.1 Preliminary work on vehicle

#### Shortening and mounting hose section

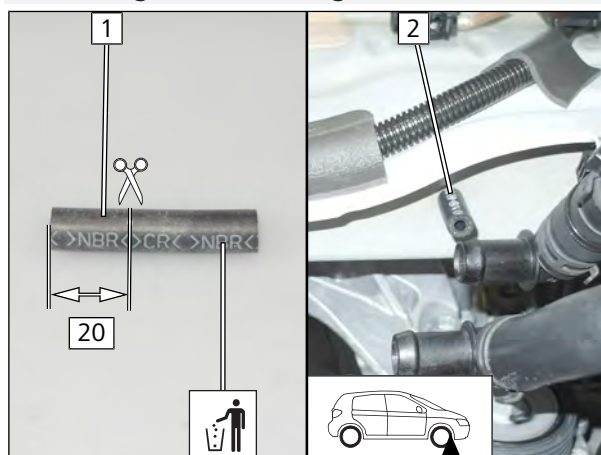

Fig. 77

- 1 Hose section Ø, 4.5
- 2 Hose section, original vehicle stud bolt

#### Removing splash guard

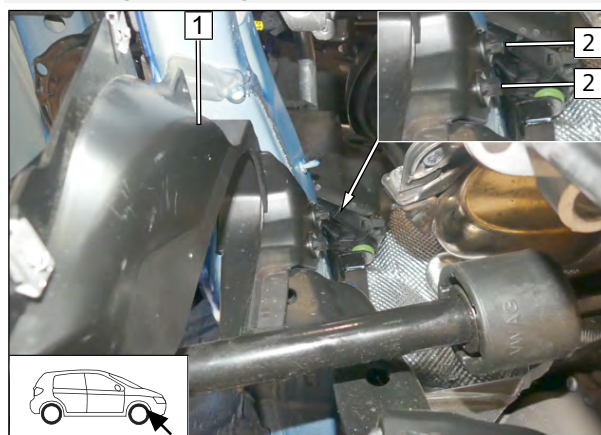

Fig. 78

- 1 Splash guard
- 2 Original vehicle plastic nut (will be reused)

#### Copying / drilling hole pattern

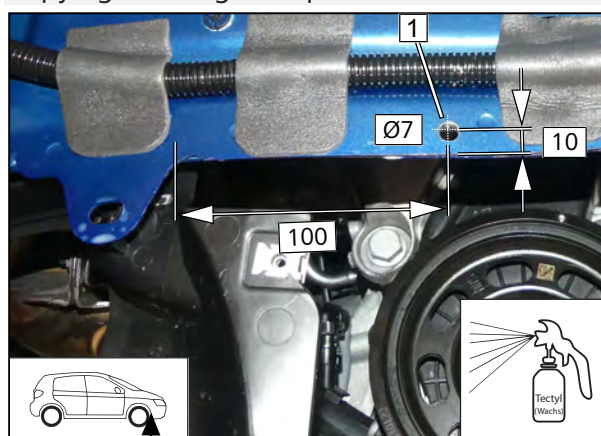

Fig. 79

- 1 Drill hole





## Bending perforated bracket

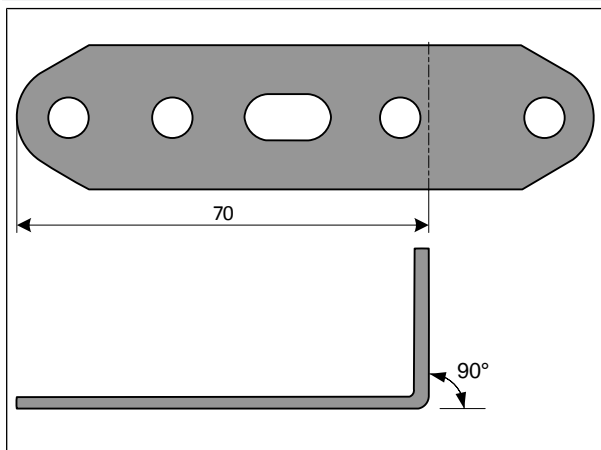
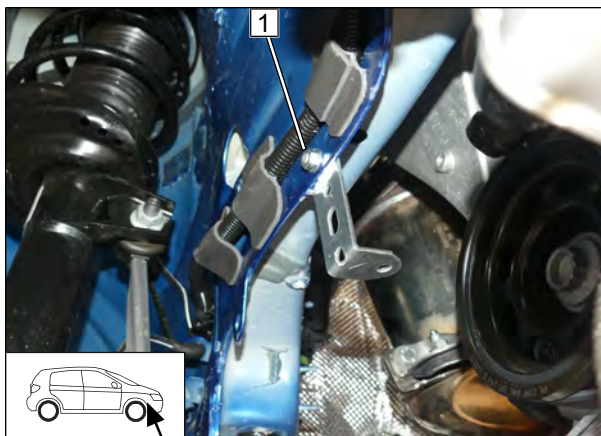

Fig. 80

## Installing perforated bracket



- 1 M6x12 bolt, perforated bracket, drilled hole, flanged nut

Fig. 81

## Removing original vehicle flanged nut

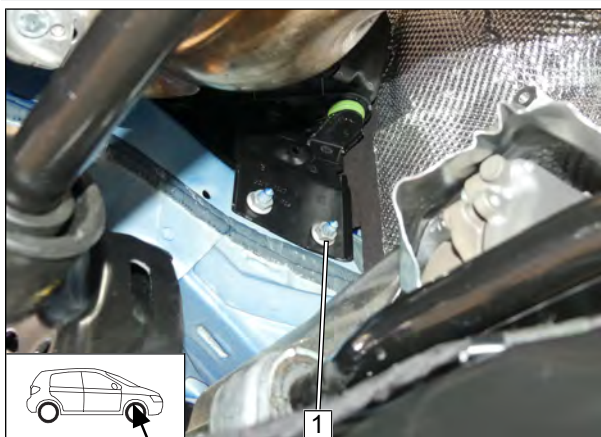

- 1 Original vehicle flanged nut (will be reused)

Fig. 82



## Spacer nut installation

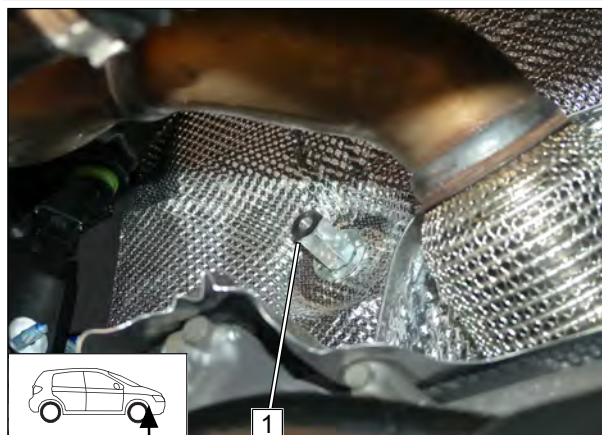

**1** M6x30 spacer nut, original vehicle stud bolt

Fig. 83

## Cutting point

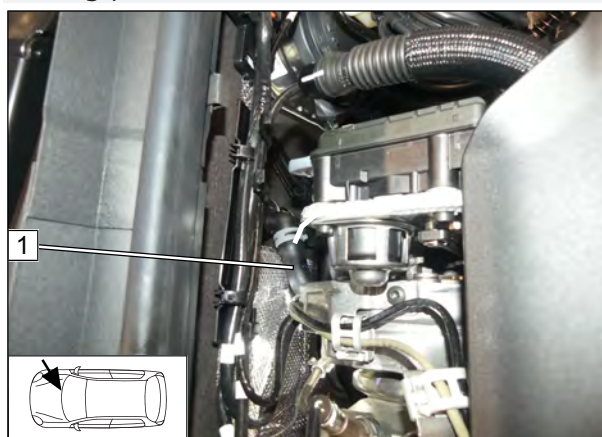

► Remove hose of engine outlet/heat exchanger inlet **1**.

Fig. 84

## 11.2 Preparing hose group

### Cutting heat protection hose to length

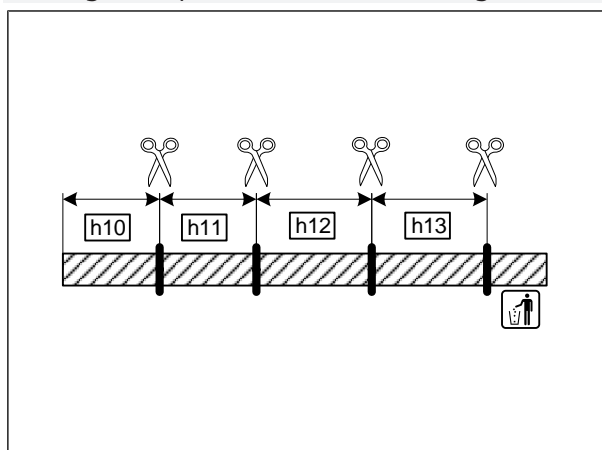

**h10** 270

**h11** 260

**h12** 300

**h13** 300

Fig. 85



## Preparing hoses **(B)** and **(K)**

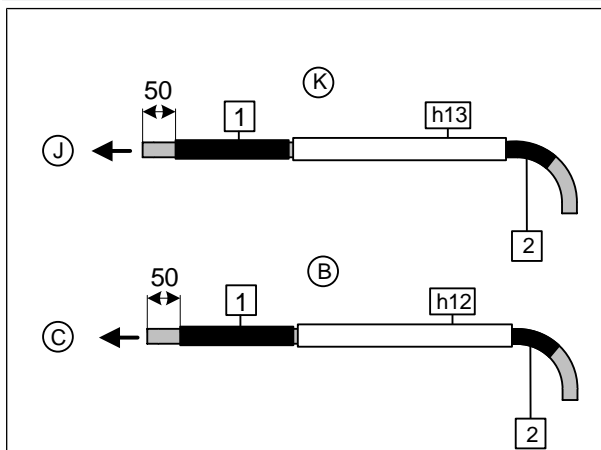

Fig. 86



Fabric heat shrink tubings **1**.

- ▶ 1. Slide on and cut to length
- ▶ 2. Shrink, use at most 230 °C



Mount heat shrink plastic tubing **2**.

- ▶ 1. Slide on and cut to length
- ▶ 2. Shrink, use at most 300 °C

## Preparing hoses **(A)** and **(L)**

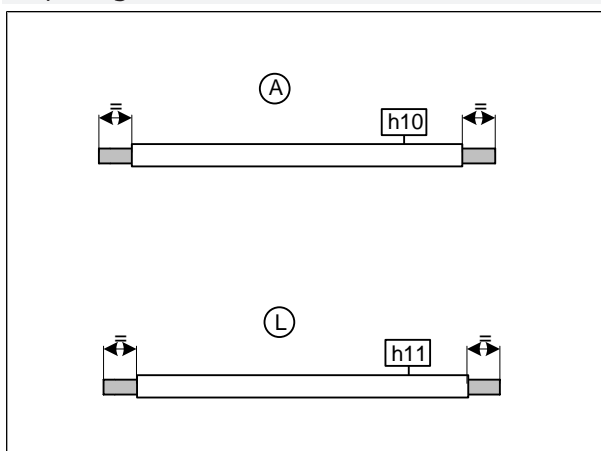

Fig. 87

## Cutting point



Fig. 88

- 1** Engine outlet hose section
- 2** Heat exchanger inlet hose section



## Preparing hose section

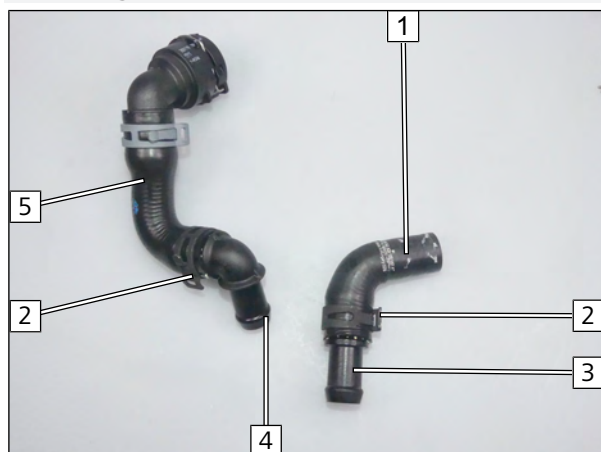

Fig. 89

- 1 Engine outlet hose section
- 2 Ø25 spring clip
- 3 Ø18/20 connecting pipe
- 4 Ø18x20, 90° connecting pipe
- 5 Heat exchanger inlet hose section

## Preparing hoses (A) and (L)

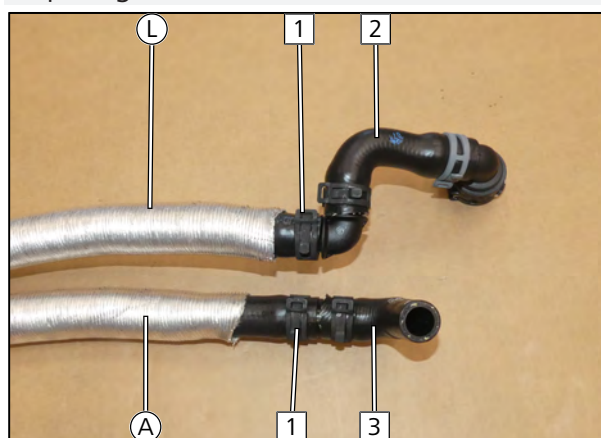

Fig. 90

- 1 Heat exchanger inlet hose section
- 2 Engine outlet hose section

## Preparing hose (B)

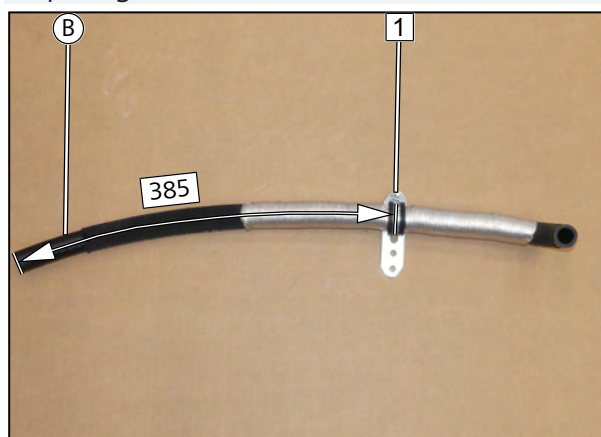

Fig. 91

- 1 M6x16 bolt, perforated bracket, Ø29 rubber-coated clamp, flanged nut





## Shortening perforated bracket

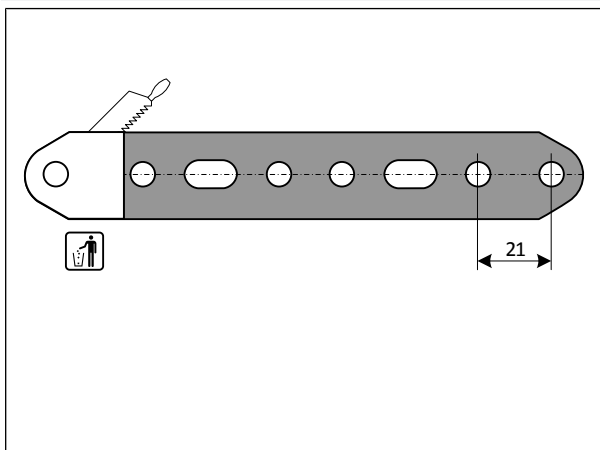

Fig. 92

## Preparing hose (K)

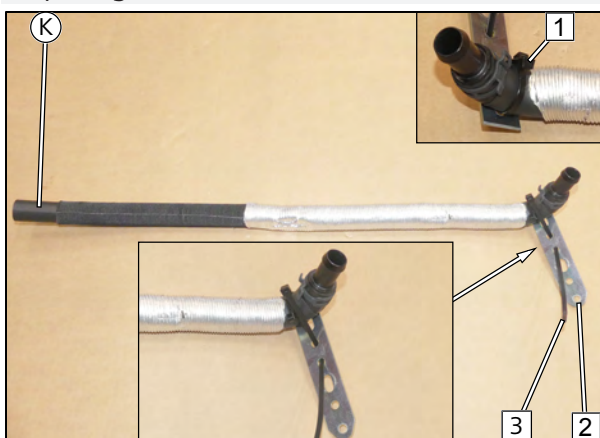

Fig. 93

- 1 Cable tie
- 2 Prepared perforated bracket

## Hose group with hoses (B) and (K)

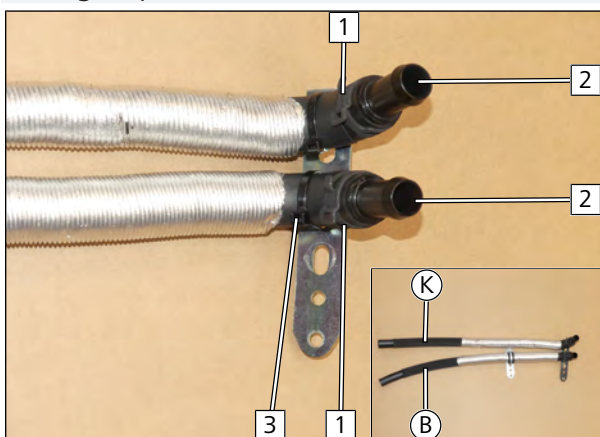
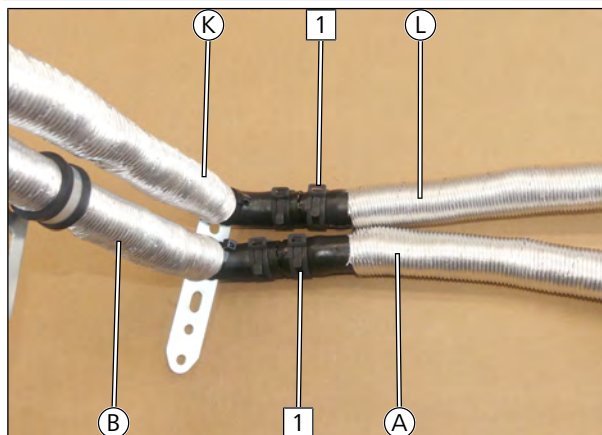

Fig. 94

- 1 Ø25 spring clip
- 2 Ø18/18 connecting pipe
- 3 Close cable tie



Mounting hoses **A**, **B** and **K**, **L**



**1** Ø25 spring clip

Fig. 95



### 11.3 Hose routing diagram

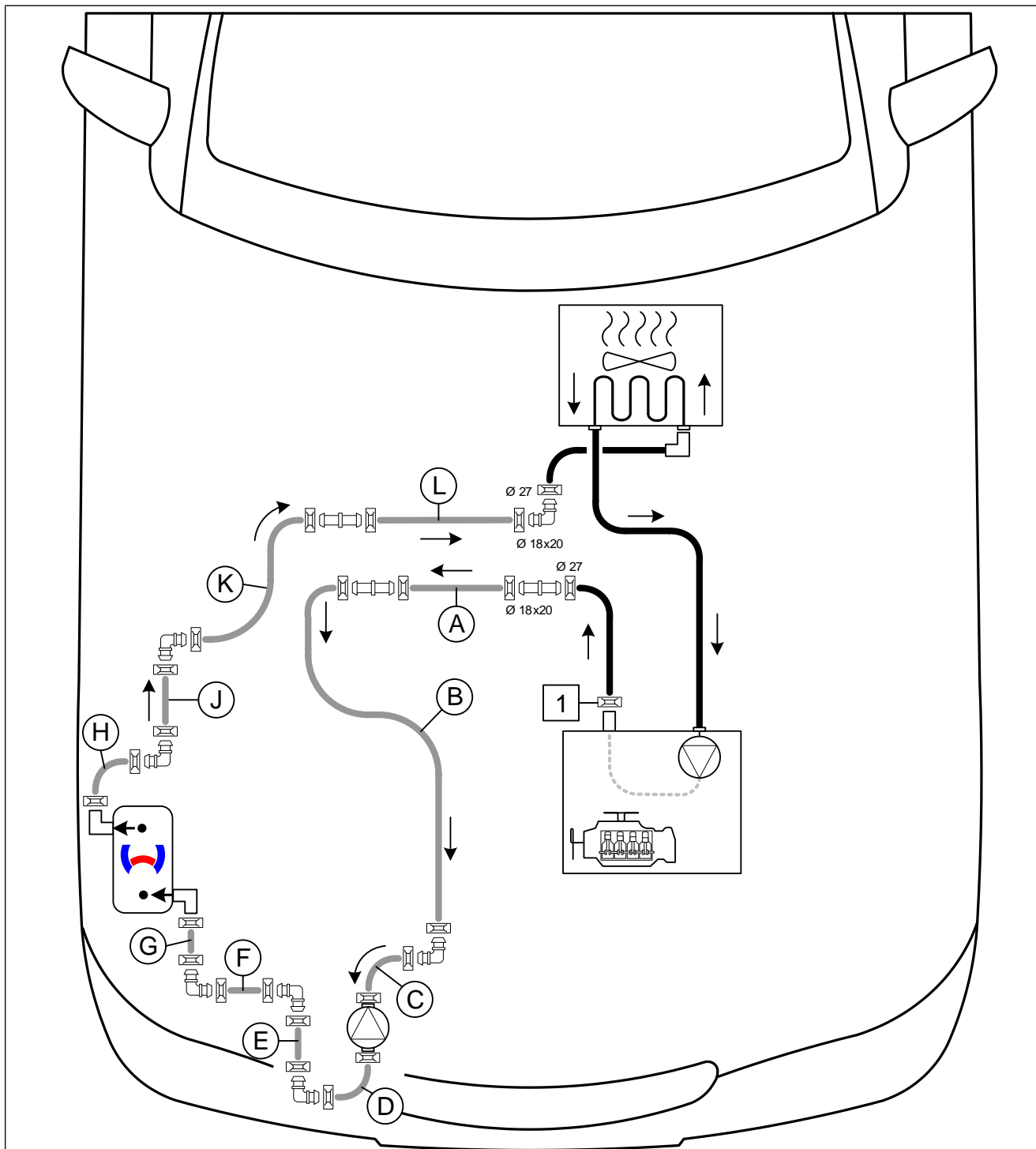

Fig. 96

All spring clips without a specific designation  = Ø25;

All connecting pipes without a specific designation  and  = Ø18x18

**1** Original vehicle spring clip



## 11.4 Coolant circuit installation

### Mounting hose group

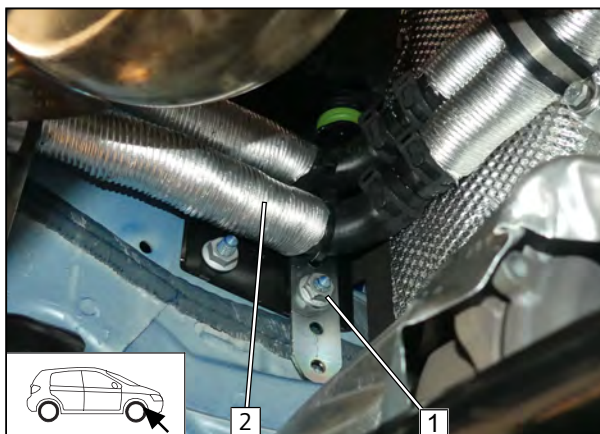

Fig. 97

- 1 Mount original vehicle stud bolt, large diameter washer, long perforated bracket, original vehicle flanged nut loosely
- 2 Hose group

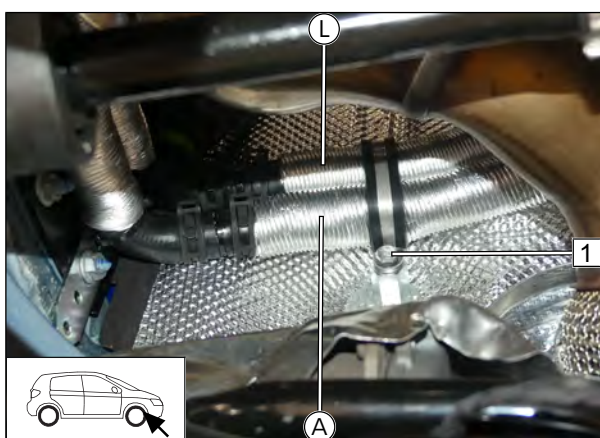

Fig. 98

- 1 Mount M6x20 bolt, spring lockwasher, Ø48 rubber-coated p-clamp loosely

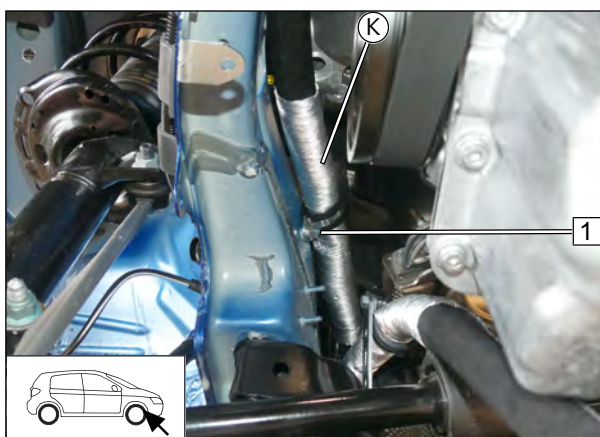
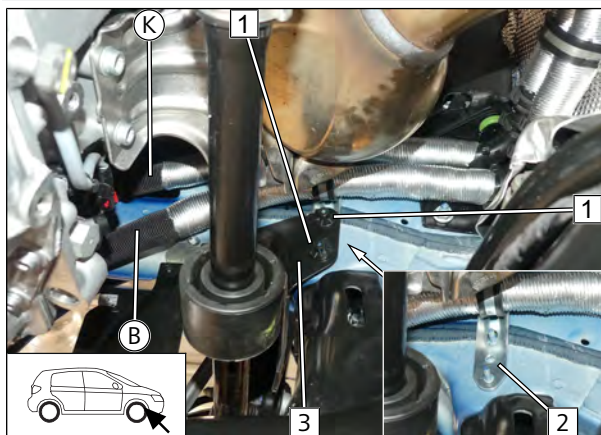

Fig. 99

- 1 Mount original vehicle stud bolt, Ø34 rubber-coated p-clamp, flanged nut loosely



## Mounting splash guard



- ▶ Attach perforated bracket **2** onto original vehicle stud bolt.
- ▶ Mount splash guard **3** with original vehicle plastic nuts **1**.

Fig. 100

## Heat exchanger inlet connection

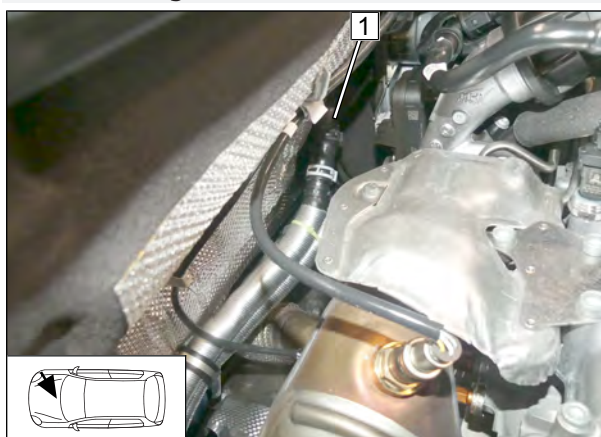

- 1** Heat exchanger inlet hose section with coupling piece

Fig. 101

## Engine outlet connection

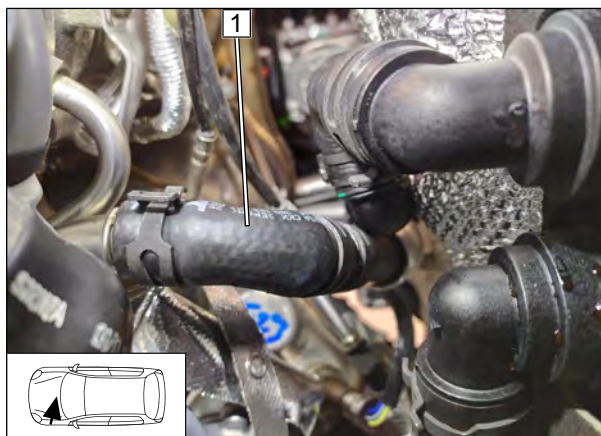

- 1** Engine outlet hose section

Fig. 102





## Connecting heater

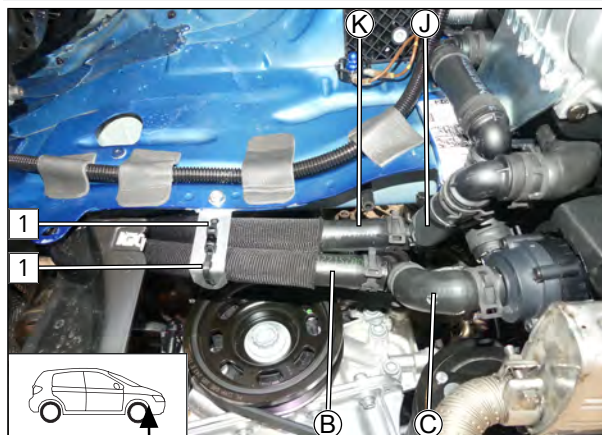

Fig. 103



Ensure sufficient distance from neighbouring components, correct if necessary.



Tighten all loosely mounted screw connections.

**1** Cable tie

## Installing cable tie

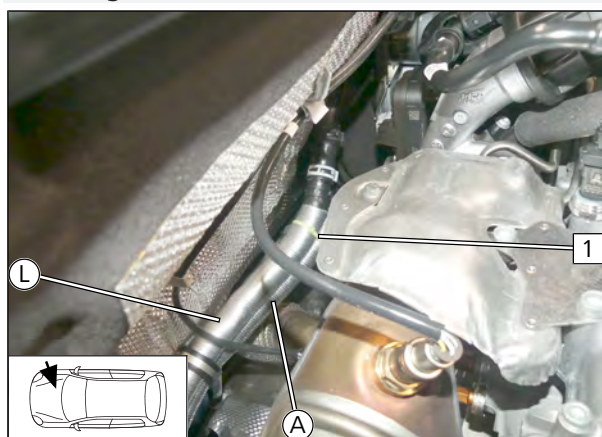

Fig. 104

► Fix hoses **A** and **L** with white cable tie.

## Distance

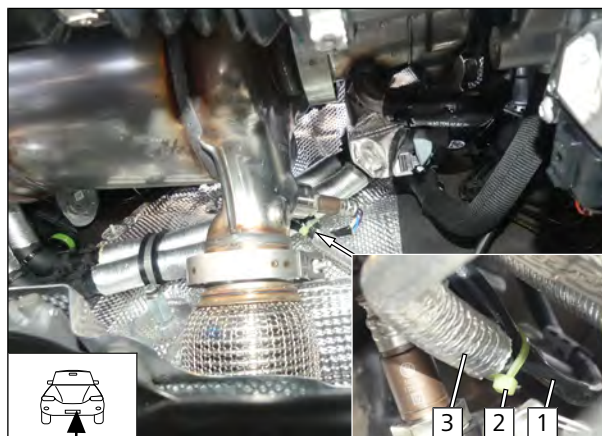

Fig. 105

**1** Original vehicle wiring harness

**2** White cable tie

**3** Original vehicle line





## 12 Final work in engine compartment

### Checking wheel-well inner panel distance

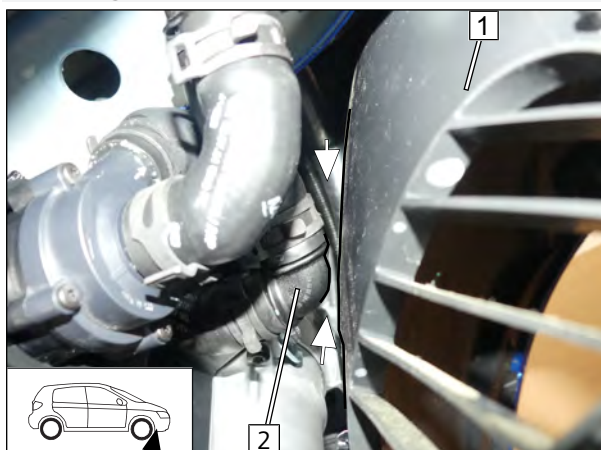

Ensure sufficient distance from neighbouring components, correct if necessary.



► Mount wheel-well inner panel **1**.

**2** Connecting pipe

Fig. 106



## 13 Electrical system of passenger compartment

### 13.1 Preliminary Work

Preparing Cronus wiring harnesses 1 and 2, assigning wires

► Insulate components, wires and connectors individually as shown and tie back.

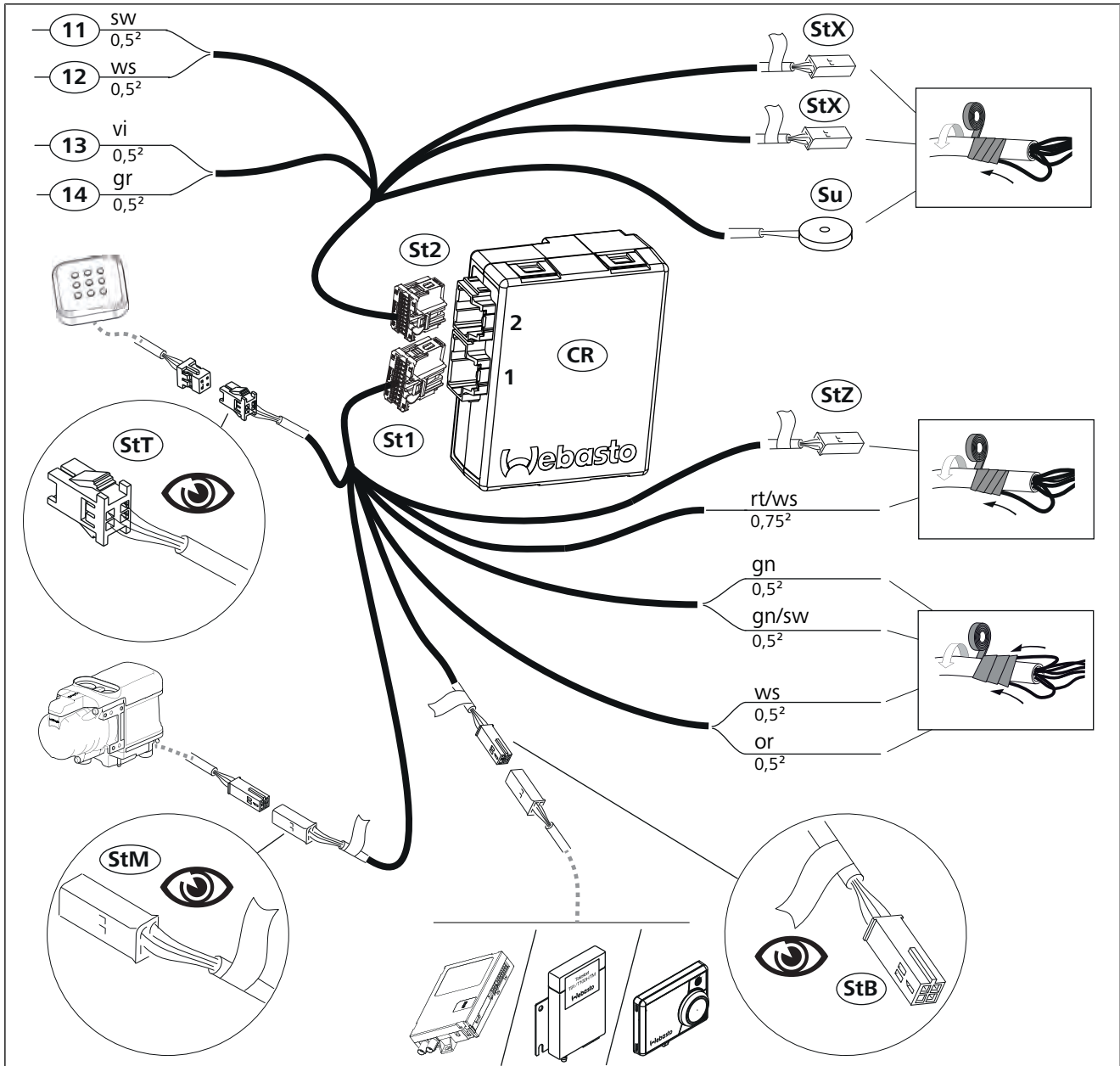

Fig. 107

### Legend

Abbreviation	Component	Abbreviation	Component
<b>CR</b>	Cronus	<b>StT</b>	4-pin male plug for push button wiring harness
<b>St1</b>	16-pin, black connector of Cronus wiring harness 1	<b>SU</b>	Buzzer, will not be used
<b>St2</b>	12-pin, grey connector of Cronus wiring harness 2	<b>StX</b>	4-pin male plug, will not be used
<b>StB</b>	4-pin female plug for control element wiring harness	<b>StZ</b>	4-pin male plug for additional relay wiring harness, will not be used
<b>StM</b>	4-pin male plug for engine compartment wiring harness		



## Preparing Cronus bracket

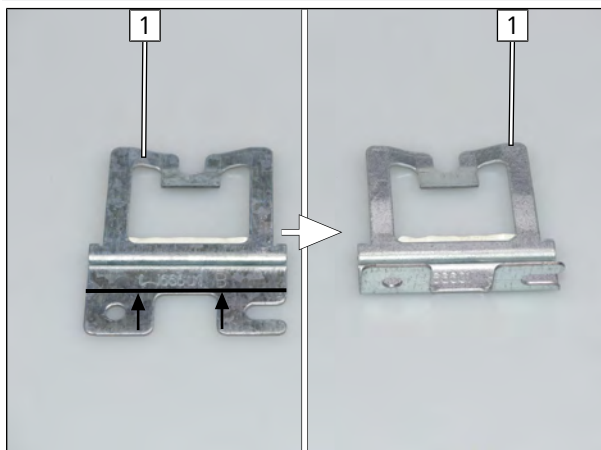

► Bend bracket **1** as shown.

Fig. 108

## Premounting Cronus

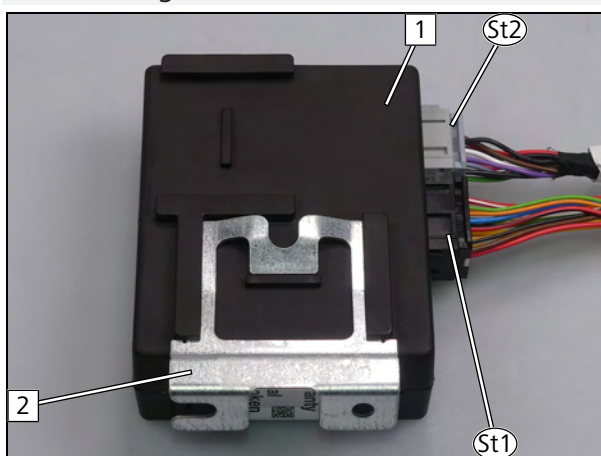

- 1** Cronus
- 2** Bracket

Fig. 109

## Preparing installation location

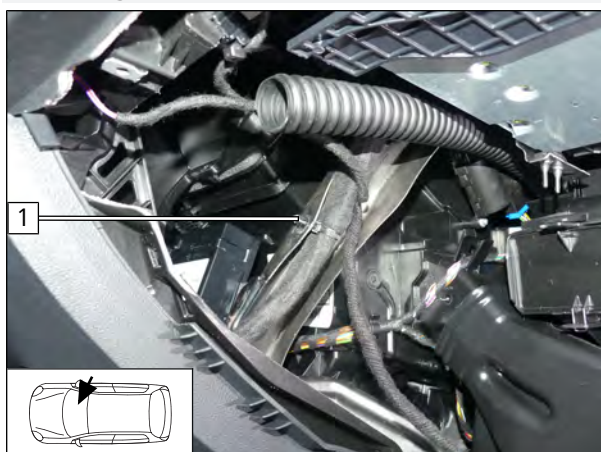

- 1** Remove and discard original vehicle clip

Fig. 110

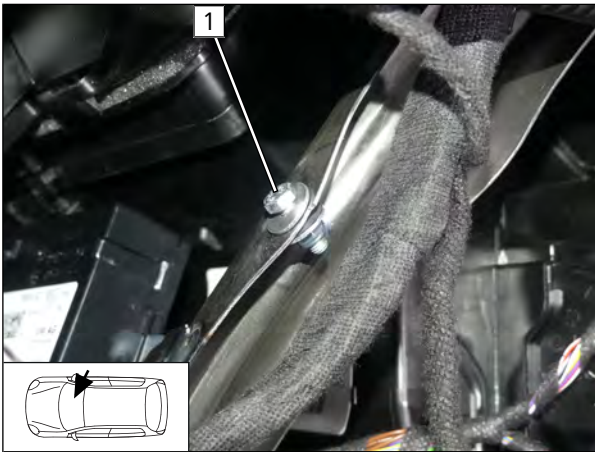

Fig. 111

- 1 Mount M5x16 bolt, large diameter washer, original vehicle hole, large diameter washer, locking nut loosely

### Locating A/C control unit wiring harness

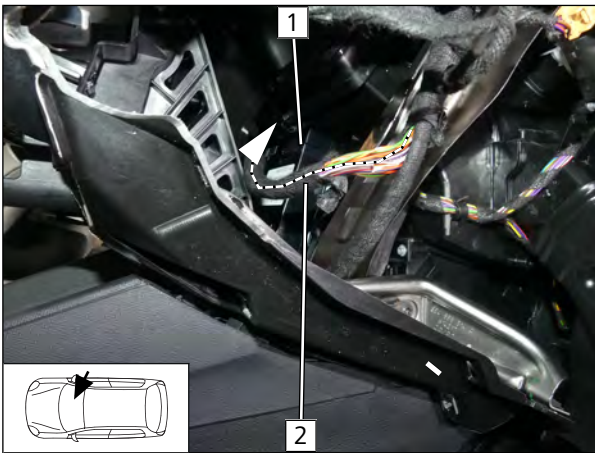

Fig. 112

- Strip insulation of original vehicle A/C wiring harness **2** carefully and locate wiring harness of A/C control unit **1**.

### Mounting Cronus

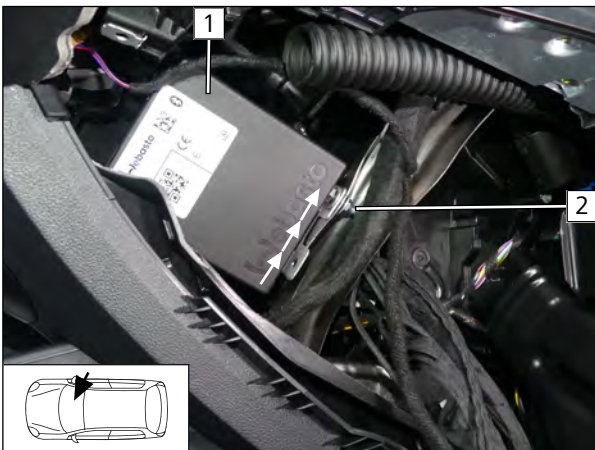

Fig. 113

- 1 Cronus
- 2 Tighten screw connections



### 13.2 Wiring diagram

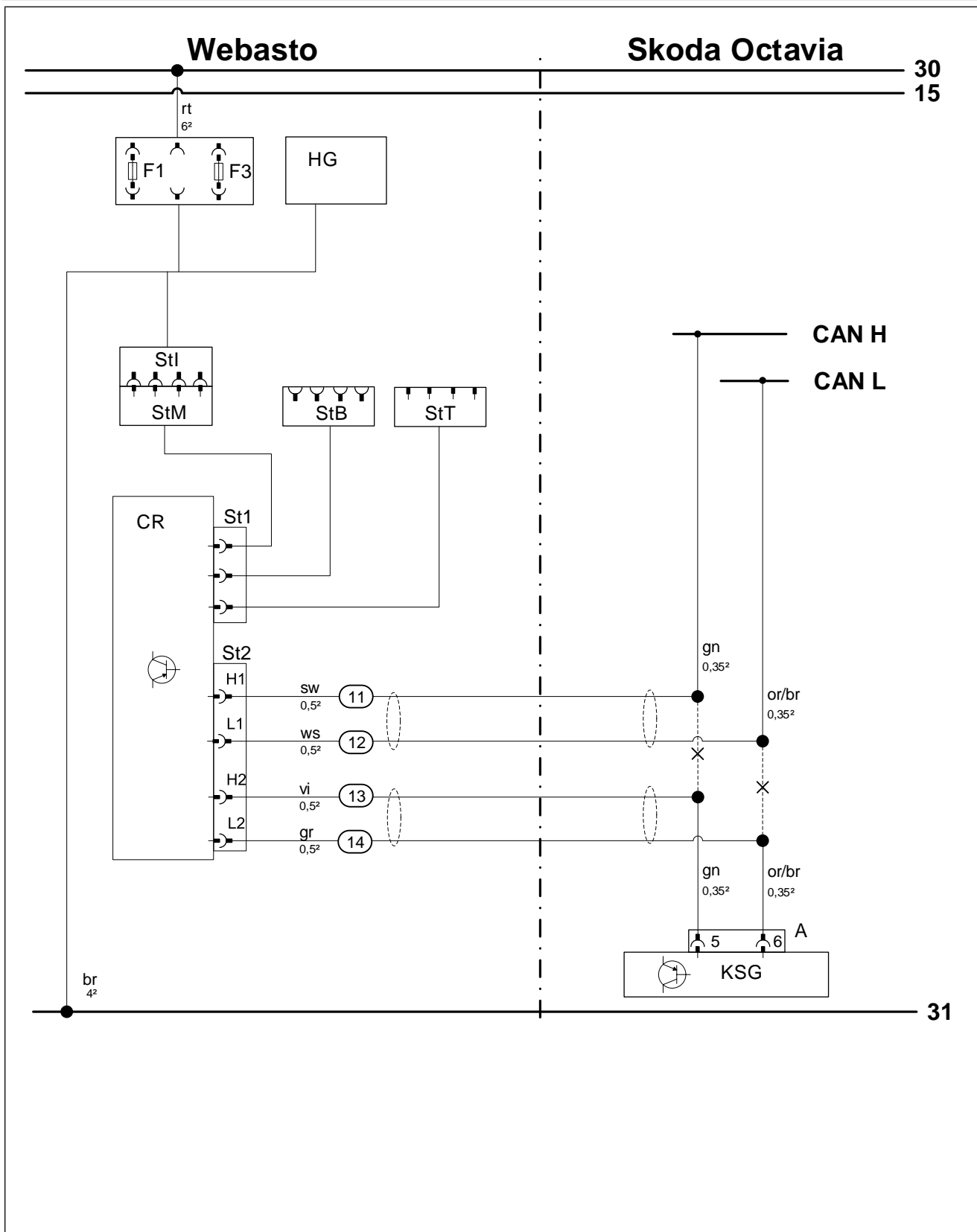

Fig. 114



## Legend to wiring diagram



The vehicle connector and component designations are freely chosen by Webasto.  
Cable colours may vary.

Vehicle components		Symbols	
Abbreviation	Component	Abbreviation	Explanation
KSG	Air-conditioning control unit	X	Cutting point
A	20-pin connector of A/C control unit		

Webasto components		Cable colours	
Abbreviation	Component	Abbreviation	Colour
CLR	Cold start module	bg	beige
CR	Cronus (passenger compartment control unit)	bl	blue
D1	Diode	br	brown
D2	Diode group	dbl	dark blue
Dia	Diagnosis connection	dgn	dark green
E	Male plug for Plug&Play wiring harness	ge	yellow
F	Female plug for Plug&Play wiring harness	gn	green
F0	Additional fuse for power supply	gr	grey
F1	Heater main fuse	hbl	light blue
F2	Fan main fuse	hgn	light green
F3	Cronus main fuse	la	salmon
HG	Heater TT-Evo	or	orange
LA	Power adapter	pk	pink
PWM GW	Pulse width modulator gateway	ro	Pink
RTD	Temperature sensor	rt	red
St1	16-pin, black connector of Cronus wiring harness 1	sw	black
St2	14-pin, grey connector of Cronus wiring harness 2	vi	violet
StB	4-pin female plug for control element wiring harness	ws	white
StI	Female plug for passenger compartment wiring harness		
StM	Male plug for engine compartment wiring harness		
StT	Male plug for push button wiring harness		
StZ	Male plug for additional relay		





### 13.3 Fan controller

#### Cutting point

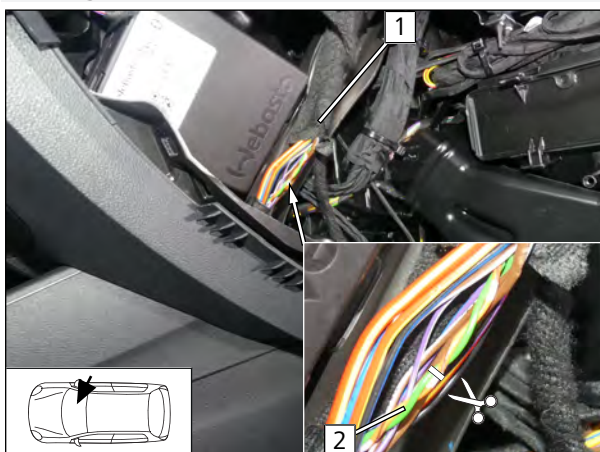

Fig. 115



▶ Detach part of the wiring harness wrapping carefully. Insulate and reinstall after completion.

▶ Locate green-orange/brown (gn-or/br) wires **2**, separate and cut them.

**1** Original vehicle wiring harness

#### Connection to air-conditioning control unit

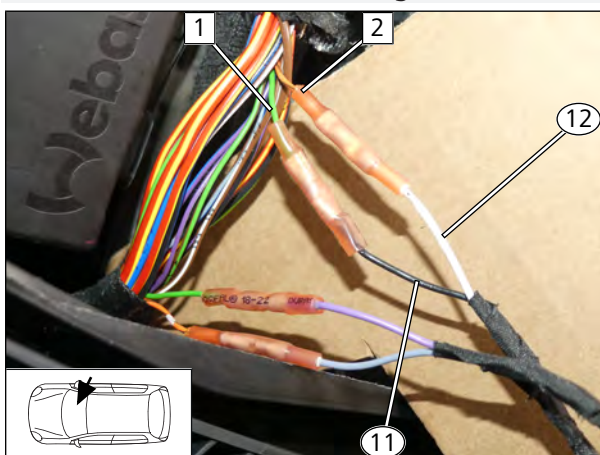

Fig. 116

**1** Green (gn) wire of CAN High

**2** Orange/brown (or/br) wire of CAN Low

**11** Black (sw) wire of Cronus wiring harness 2

**12** White (ws) wire of Cronus wiring harness 2

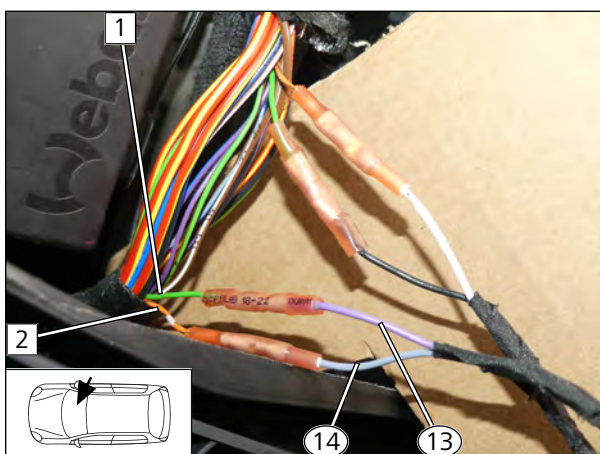

Fig. 117

**1** Green (gn) wire of KSG connector A / pin 5

**2** Orange/brown (or/br) wire of KSG connector A / pin 6

**13** Violet (vi) wire of Cronus wiring harness 2

**14** Grey (gr) wire of Cronus wiring harness 2

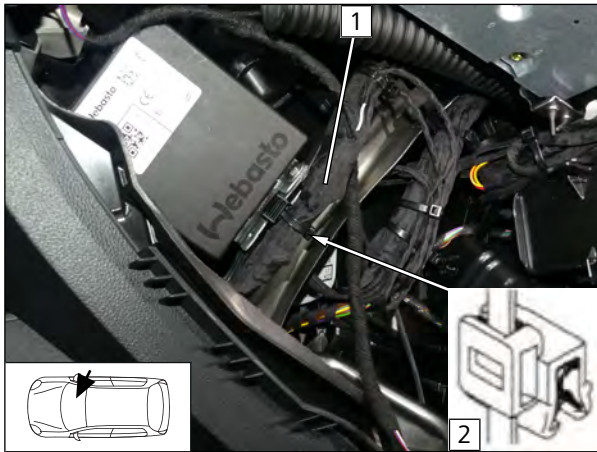

- Insulate Cronus wiring harness **1** as well as butt connector with adhesive tape on original vehicle wiring harness. Attach wiring harness with edge clip cable tie **2**.

Fig. 118



### 13.4 Connection of Cronus to push button



The installation location of the Cronus push button should be confirmed with the end customer and should comply with the installation conditions.

- ▶ Mount the push button and connect the marked male plug of Cronus wiring harness 1 with the connection plug of the Cronus push button as shown.

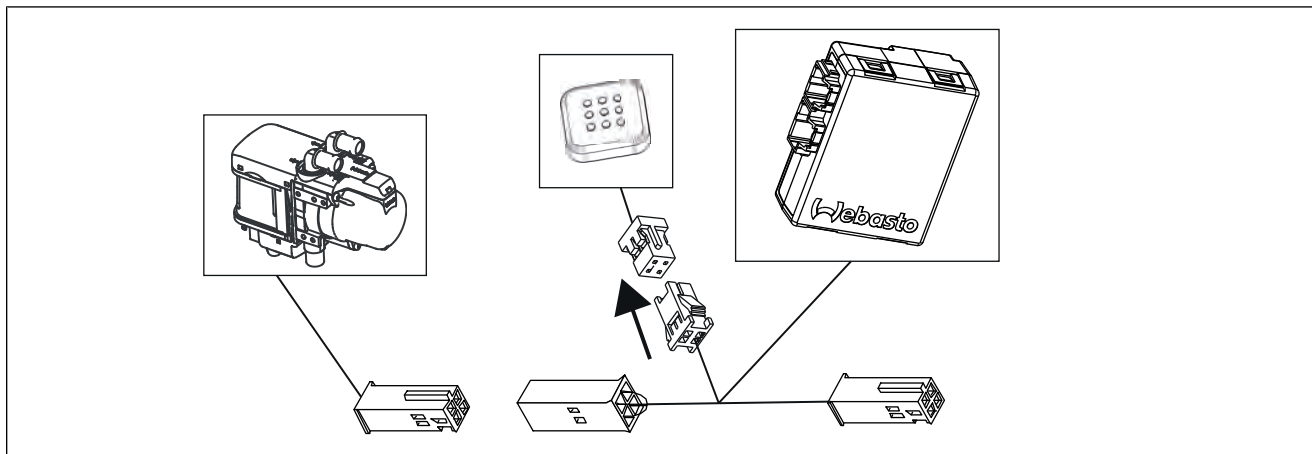

Fig. 119

### 13.5 Heater connection and installation of Telestart or MultiControl AM control element



Install the control element in accordance with the provided relevant general installation documentation. The installation location of the optional control element MultiControl or the push button of the Telestart option should be confirmed with the end customer and should comply with the installation conditions.

- ▶ Connect the marked male and female plugs of Cronus wiring harness 1 with the connection plug of the engine compartment wiring harness and the relevant control element as shown.

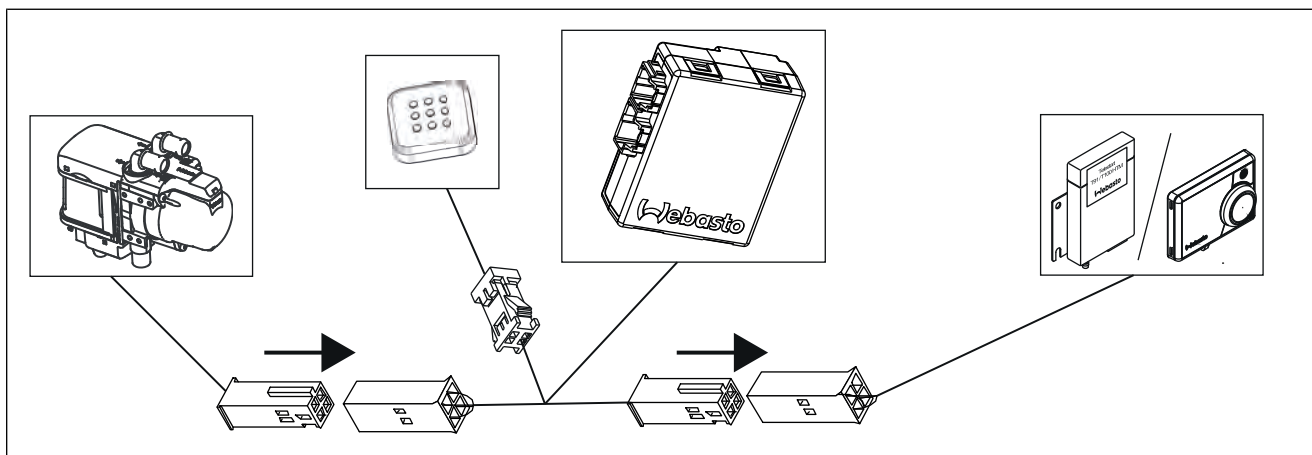

Fig. 120



## 13.6 Heater connection and installation of ThermoConnect control element



Install the control element in accordance with the provided relevant general installation documentation. The installation location of the push button of the ThermoConnect option should be confirmed with the end customer and should comply with the installation conditions.

### Preparing Y wiring harness



The Y wiring harness mentioned in section 'Components used' must also be ordered.

- ▶ Locate connection plug **2** of ThermoConnect wiring harness on the wiring harness branch of Y wiring harness **1**.
- ▶ Disconnect black (sw) wire **3** from connection plug **2**, tie back and insulate.

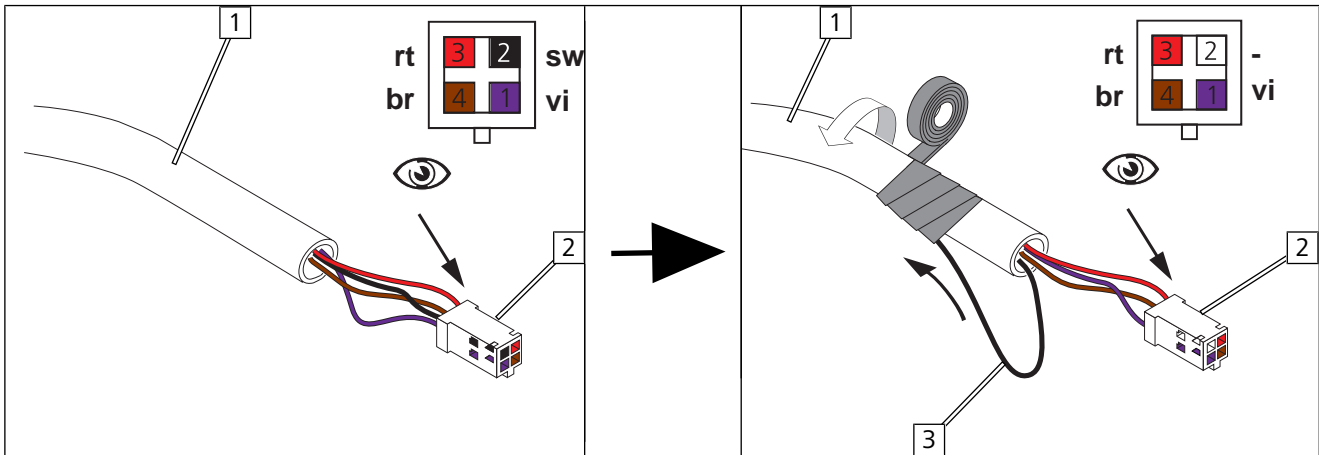

Fig. 121

### Connecting wiring harnesses

- ▶ Connect the marked female plug **1** of Cronus wiring harness 1 and connection plug **2** of engine compartment wiring harness with Y wiring harness **3** and connect connection plug **4** of the ThermoConnect wiring harness with prepared connector **5** of Y wiring harness as shown.

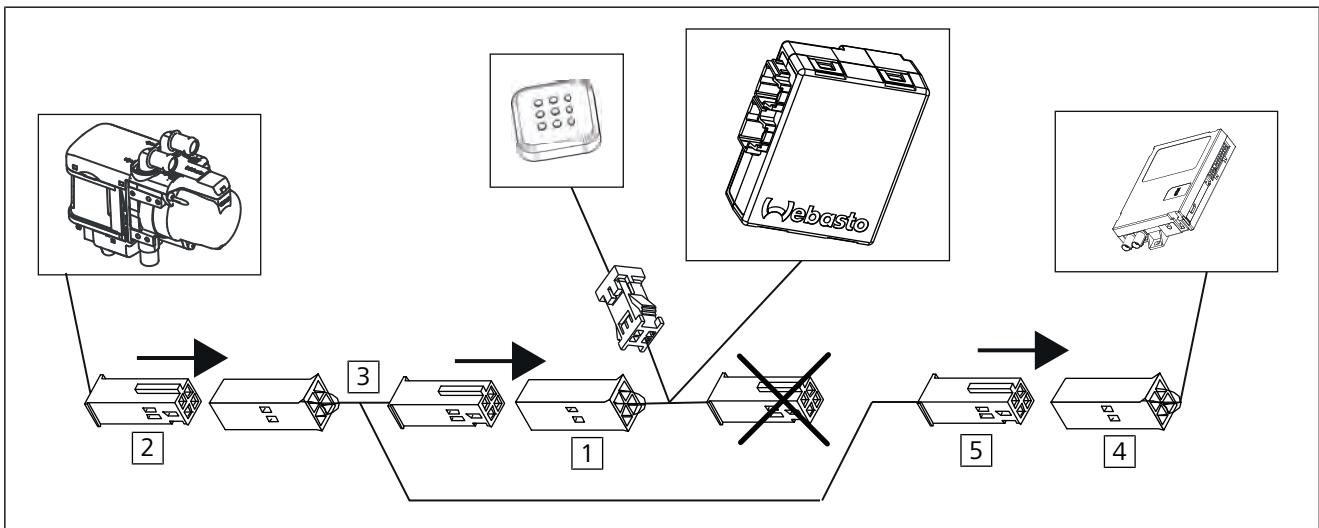

Fig. 122



## 14 Final Work



Further information can be found in the vehicle manufacturer's technical documentation.

- ▶ Mount removed parts in reverse order.



- ▶ Check all hoses, clamps and all electrical connections for firm seating.
- ▶ Insulate and tie back loose lines
- ▶ Spray heater and electrical components with anti-corrosion wax (Tectyl 100K).
- ▶ Connect the battery.



**Only use manufacturer-approved coolant.**

- ▶ Fill and bleed the coolant circuit according to the vehicle manufacturer's specifications.



Further information can be found in the general installation and operating instructions of the Webasto components.

- ▶ Initialisation of Cronus with the Webasto Thermo Test Diagnosis:
  - ⇒ Activate the 'Cronus' application, initiate the start-up then follow and carry out the instructions in the indicated sequence
  - ⇒ Save or print the final report
- ▶ Program MultiControl CAR, pair Telestart transmitter
- ▶ Make settings on A/C control panel according to the 'Operating Instructions'
- ▶ Initial start-up and function check
- ▶ Affix 'Switch off parking heater before refueling' caution label in area of filler neck



**Vehicle event log after parking heating mode**

- ✓ Components of the original vehicle air conditioning system are activated during parking heating mode. Other vehicle components remain inactive, which in some circumstances may be interpreted as an error and can be filed as such in the event log. An increased power consumption (quiescent current) may also be registered for some vehicles.
- ▶ If an incorrect installation can be excluded, these entries are exclusively related to the parking heating mode situation and have no effect on the vehicle functions in driving mode.

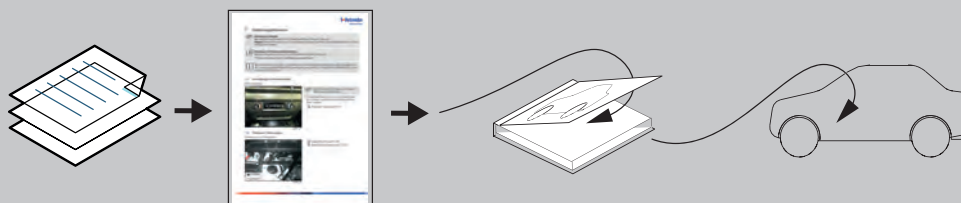



These are the original instructions. The German language is binding.  
You can request your language if it is missing. The telephone number of each country can be found in the Webasto service centre leaflet or the website of the respective Webasto representative of your country.

© Copyright 2021 - The contents of this document, including but not limited to text, photographs and graphics, are protected by copyright. All rights, including reproduction, publication, editing and translation in any way, shape or form, are reserved by Webasto.

Webasto Thermo & Comfort SE  
Postfach 1410  
82199 Gilching  
Germany

Company address:  
Friedrichshafener Str. 9  
82205 Gilching  
Germany

Technical Extranet: <https://dealers.webasto.com>



WWW.WEBASTO.COM



## 15 Template of bracket

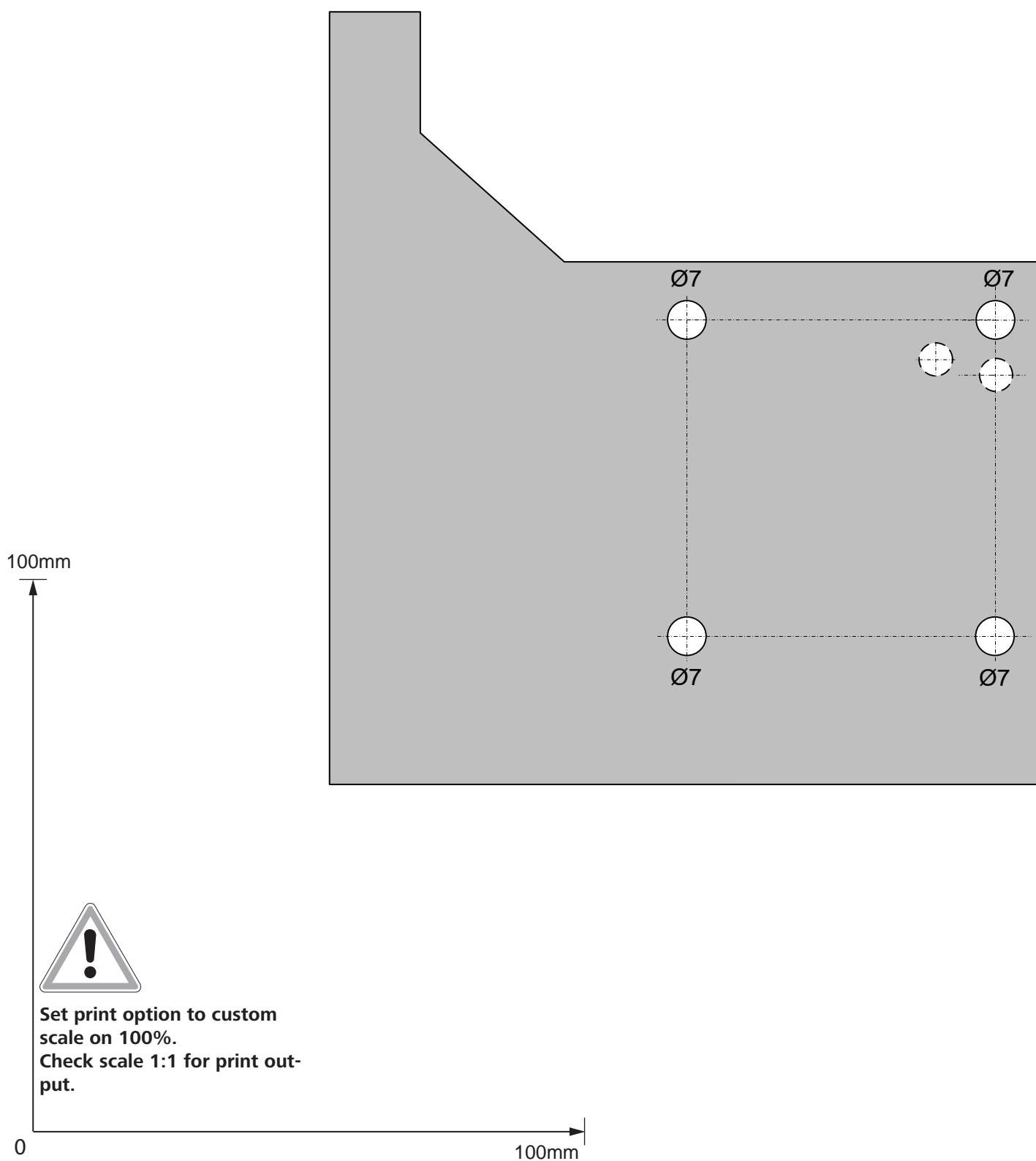





## 16 FuelFix drilling template

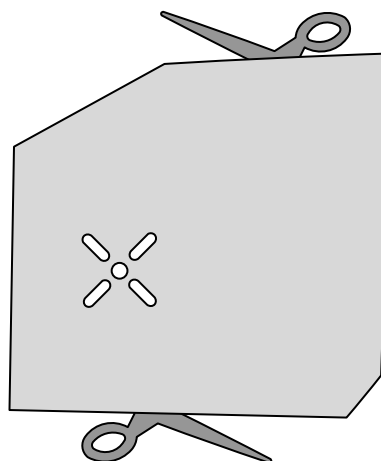

100mm



**Set print option to custom  
scale on 100%.  
Check scale 1:1 for print out-  
put.**

0

100mm







## 17 FuelFix template

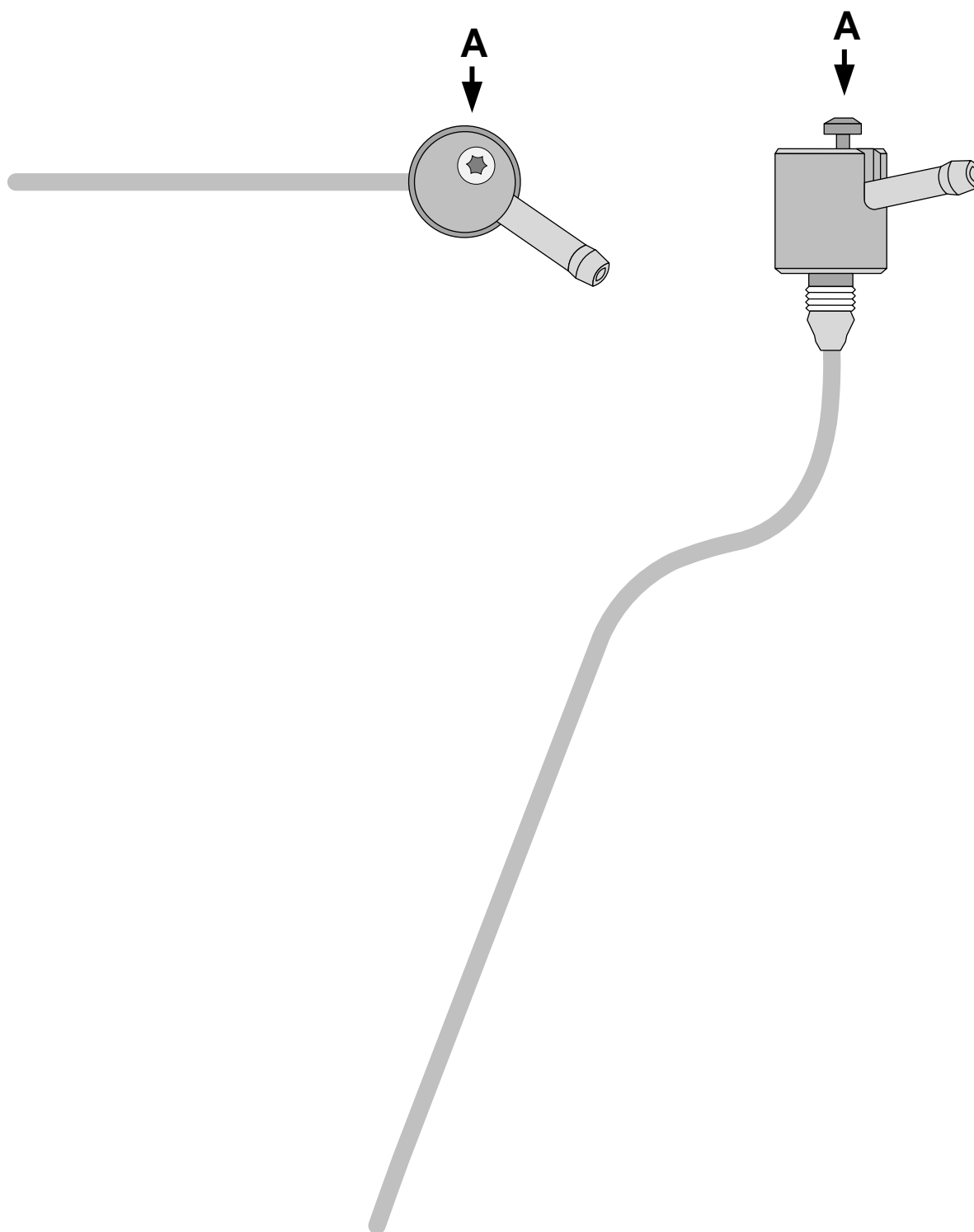

**Set print option to custom scale on 100%.  
Check scale 1:1 for print output.**

0

100mm



## 18 Operating instructions



### Vehicles with passenger compartment monitoring:

Further information can be found in the vehicle operating instructions.

- ▶ Deactivate passenger compartment monitoring for the heating operation



### Information regarding the heating time:

We recommend matching the heating time to the driving time (heating time = driving time)

**Example:** for a driving time of approx. 20 min. (in one direction), we recommend not exceeding a switch-on time of 20 min.



### Notes about the A/C control panel presettings

Your vehicle is equipped with a comfort air-conditioning control. As a result, **no** settings are required on the A/C control panel when switching off the vehicle. All necessary presettings, such as fan speed, temperature and flap positions are set automatically.



### Note for parking heater function

Your vehicle is equipped with a passenger compartment and engine preheating unit.



### Notes on parking heater exhaust outlet <sup>1</sup>

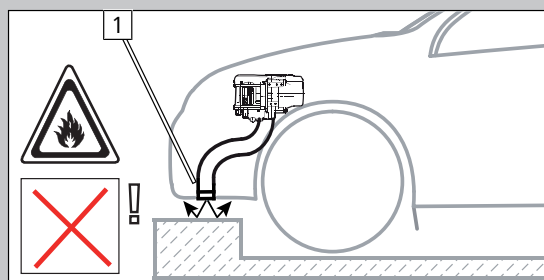
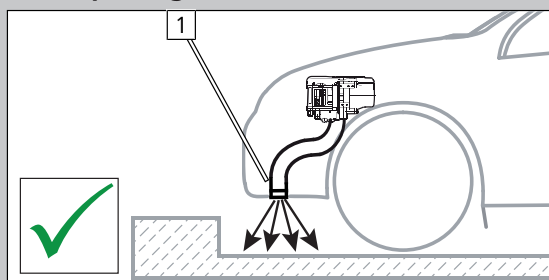

## 18.1 Installation location of fuses

### Fuses in engine compartment



- 1** F3 - 5A Cronus main fuse
- 2** F2 - not in use
- 3** F1 - 20A heater main fuse

Fig. 123

