

K Installation documentation

for water heater Thermo Top Evo

'Inline' coolant circuit with engine preheating

VW Golf VIII

Left-hand drive vehicle

Manufacturer	Model	Type	Model year	EG-BE-No. / ABE		
VW	Golf VIII	CD	from 2020	e1* 2007/46* 2180*...		
Motorisation	Fuel	Emission standard	Transmission type	Output [kW]	Displacement [cm ³]	Engine code
2.0TDi	Diesel	Euro 6d Temp	DSG	110	1968	DTSB

Validity	Equipment variants	Model
		Golf VIII
Verified equipment variants	Automatic air-conditioning (dual zone)	x
	Automatic air-conditioning (3-zone)	x
	IQ Light – LED Matrix headlights	x
	LED headlight	x
	LED daytime running lights	x
	Keyless Go	x
	Automatic Start-Stop system	x
	Start button	x
	Alarm system	x

Total installation time	Note
8.4 hours	

Contents

1	List of abbreviations	3	13	FuelFix drilling template	55
2	Installation notes	4	14	FuelFix template	57
2.1	Information on Validity	4	15	Operating instructions	59
2.2	Components used	4	15.1	Installation location of fuses	59
2.3	Notes on installation, in coordination with the end customer	4			
2.4	Information on Total Installation Time	4			
3	About this document	5			
3.1	Purpose of the document	5			
3.2	Warranty and liability	5			
3.3	Safety	5			
3.4	Using this document	6			
4	Technical Information	7			
5	Preparations	8			
5.1	Vehicle preparation	8			
5.2	Heater preparation	8			
6	Installation overview	9			
7	Electrical system of engine compartment	10			
8	Mechanical system	15			
8.1	Installation location preparation	15			
8.2	Heater assembly installation	17			
9	Fuel	20			
9.1	Routing fuel line	20			
9.2	Installing FuelFix	25			
10	Coolant	30			
10.1	Preliminary work on vehicle	30			
10.2	Preparing hoses	32			
10.3	Hose routing diagram	34			
10.4	Coolant circuit installation	35			
11	Final work	38			
12	Electrical system of passenger compartment	40			
12.1	Dismantling Instructions	40			
12.2	Preliminary Work	45			
12.3	Wiring diagram	48			
12.4	Fan controller	50			
12.5	Connection of Cronus to push button	52			
12.6	Heater connection and installation of Telestart or MultiControll AM control element	52			
12.7	Heater connection and installation of ThermoConnect control element	53			

1 List of abbreviations

CR	Cronus (passenger compartment control unit)
DP	Fuel pump
DSG	Direct gear transmission
FF	FuelFix (tank extracting device)
HG	Heater
KSG	Air-conditioning control unit
MY	Model year
SH2	Engine compartment fuse holder for F1/F2/F3
UP	Coolant pump
Veh.	Vehicle

2 Installation notes

2.1 Information on Validity

This installation documentation applies to vehicles listed on page 1, assuming technical modifications to the vehicle do not affect installation, any liability claims excluded. Depending on the vehicle version and equipment, modifications may be necessary during installation with respect to this installation documentation. Vehicle and engine types, equipment variants and other specifications not listed in this installation documentation have not been tested. However, installation according to this installation documentation may be possible.

2.2 Components used

Designation	Order number
Delivery scope for VW Golf VIII diesel Cronus MY 2020 TT-Evo	1328391A
In case of Telestart, control element, as well as indicator lamp in consultation with end customer	In accordance with price list
The following must also be ordered for the ThermoConnect option: retrofitting Y adapter wiring harness	1319820_

2.3 Notes on installation, in coordination with the end customer

- ▶ Arrange for the vehicle to be delivered with the tank only about ¼ full.
- ▶ The installation location of the following elements should be chosen in coordination with the end customer:
 - the Cronus push button as well as the push button in case of the Telestart and/or ThermoConnect options
 - the MultiControl CAR option

2.4 Information on Total Installation Time

The total installation time includes the time needed for mounting and demounting the vehicle-specific components, the heater specific installation time and all other times required for the system integration and initial start-up of the heater.

The total installation time may vary for vehicle equipment other than provided.

3 About this document

3.1 Purpose of the document

This installation documentation is part of the product and contains all the information required to ensure professional vehicle specific installation of the:

Thermo Top Evo heater

3.2 Warranty and liability

Webasto shall assume no liability for defects, damage and injuries resulting from a failure to observe the installation, repair and operating instructions of the information contained in them.

This liability exclusion particularly applies to improper installations and repairs by untrained persons or in the case of a failure to use genuine spare parts.

The liability due to culpable disregard to life, limb or health and due to damage or injuries caused by a wilful or reckless breach of duty remain unaffected, as does the obligatory product liability.

Installation should be carried out according to the general, standard rules of technology. Unless specified otherwise, fasten hoses, lines and wiring harnesses to original vehicle lines and wiring harnesses using cable ties. Insulate loose wire ends and tie back. Connectors on electronic components must audibly snap into place during assembly.

Spray unfinished body areas, e.g. drilled holes, with anti-corrosion wax (Tectyl 100K).

Observe the instructions and guidelines of the respective vehicle manufacturer for demounting and mounting vehicle specific components.

The initial start-up is to be executed with the Webasto Thermo Test Diagnosis.

When installing a programmable control module (e.g. a PWM Gateway), the corresponding settings must be checked or adjusted.

3.2.1 Statutory regulations governing installation

The Thermo Top Evo heater has been type-tested and approved in accordance with ECE-R 10 (EMC) and ECE-R 122 (heater). The regulations of these guidelines are binding in the scope of the Directive 70/156/EEC and/or 2007/46/EC (for new vehicle models from 29/04/2009) and should also be observed in countries in which there are no special regulations.

The heater is licensed in accordance with paragraph 19, section 3, No. 2b of the StVZO (German Road Traffic Licensing Authority).

3.3 Safety

Qualifications of installation personnel

The installation personnel must have the following qualifications:

- Successful completion of Webasto training
- Corresponding qualification for working on technical systems

Regulations and legal requirements

The regulations from the heater's general installation and operating instructions must be observed.

3.3.1 Safety information on installation

Danger posed by live parts

- ▶ Prior to installation, disconnect the vehicle from the voltage supply.
- ▶ Make sure the electrical system is earthed correctly.
- ▶ Always comply with legal requirements.
- ▶ Observe data on type label.

Danger of fire and leaking toxic gases due to improper installation

- ▶ Vehicle parts in the vicinity of the heater must be protected against excessive heating by the following measures:
 - ⇒ Maintain minimum safety distances.
 - ⇒ Ensure adequate ventilation.
 - ⇒ Use fire-resistant materials or heat shields.

Danger due to sharp edges

- Lacerations
- Short circuit due to electrical wire damage
- ▶ Fit protectors on sharp edges.

3.4 Using this document

Before installing and operating the heater, read this installation documentation, the installation instructions of the heater, the operating instructions and supplementary sheets provided.

3.4.1 Explanatory Notes on the Document

There is an identification mark near the respective work step to allow you to quickly allocate the other applicable documents to the Webasto components to be installed:

Generally valid Webasto documentation	
Vehicle-specific installation documentation	
Vehicle-specific installation documentation of the cold start kit	
Webasto Comfort A/C control	
Webasto Standard A/C control	
Tank extracting device (e.g. FuelFix)	
Exhaust end fastener (EFIX)	
Combustion air intake silencer	
Spacer bracket (ASH)	

3.4.2 Use of symbols



DANGER

Type and source of the risk

Consequences: Failure to follow the instructions can result in death

► Actions to protect yourself against risks.



WARNING

Type and source of the risk

Consequences: Failure to follow the instructions can lead to serious or even fatal injuries

► Actions to protect yourself against risks.



CAUTION

Type and source of the risk

Consequences: Failure to follow the instructions can lead to minor injuries

► Actions to protect yourself against risks.



Type and source of the risk

Consequences: Failure to follow the instructions can lead to material damage

► Actions to protect yourself against risks.



Reference to the vehicle manufacturer's specific documents.



Note on a special technical feature

3.4.3 Work step identification marks

The ongoing work step is indicated on the outside top corner of the page:

Mechanical system	Electrical system	High-voltage	Coolant
Combustion air	Fuel	Exhaust	Software

3.4.4 Orientation aid

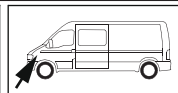
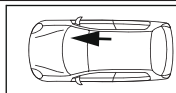

The arrow indicates the position on the vehicle and the viewing angle

3.4.5 Use of highlighting

Highlight	Explanation
✓	Action
►	Necessary action
⇒	Result of an action
1 / 12 / a1	Position numbers for the image descriptions
① / ⑫ / Ⓐ	Position numbers for the image descriptions for electrical wires and components as well as coolant hose sections

4 Technical Information

Dimension specifications

- All dimensions specified in mm
- Perforated brackets and mounting angles are shown to scale
- Observe data regarding scale on the templates

Tightening torque specifications

- Tightening torque values of 5x13 heater bolts and 5x11 heater stud bolts = 8Nm
- Tightening torque values of 5x15 retaining plate of water connection piece bolts = 7Nm
- 5x12 bolt tightening torque of 2-part heater bracket = 6Nm
- Tighten other bolt connections in accordance with manufacturer's instructions or in accordance with state-of-the-art-technology

Temperature specification for heat shrink plastic tubings

- Fabric heat shrink tubing: shrink temperature max. 230°C
- Standard heat shrink plastic tubing: shrink temperature max. 300°C

Necessary special tools

- Hose clamp pliers for auto-tightening hose clamps
- Hose clamp pliers for Clic hose clamps of type W
- Hose clamping pliers
- Hose cutter
- Automatic wire stripper 0.2 - 6 mm²
- Crimping pliers for cable lugs 0.5 – 10 mm²
- Crimping pliers for male connector 0.14 – 6 mm²
- Crimping pliers for connector 0.25 – 6 mm²
- Torque wrench for 2.0 - 10 Nm
- Deep-hole marker
- Metric thread-setter kit
- Webasto Thermo Test Diagnosis with current software

5 Preparations

5.1 Vehicle preparation



Further information can be found in the vehicle manufacturer's technical documentation.

Vehicle area	Components to be removed	Other applicable documents
General	<ul style="list-style-type: none"> ▶ Open the fuel tank cap ▶ Ventilate the fuel tank ▶ Close the fuel tank cap again ▶ Depressurise the cooling system 	
Engine compartment and body	<ul style="list-style-type: none"> ▶ Disconnect the battery ▶ Engine design cover ▶ Air filter complete with intake box above the radiator ▶ Battery ▶ Battery carrier ▶ Engine compartment relay and fuse box cover ▶ Front wheel on the front passenger's side ▶ Wheel well trim on the front passenger's side (front part) ▶ Engine underride protection ▶ Underbody underride protection on the front passenger's side 	
Passenger compartment	<ul style="list-style-type: none"> ▶ Side instrument panel trim on the driver's and front passenger's side ▶ A/C control unit (see dismantling instructions) ▶ Rear bench seat ▶ Open the tank fitting service lid on the front passenger's side 	

5.2 Heater preparation

Engine compartment	<ul style="list-style-type: none"> ▶ Remove years that do not apply from the type and duplicate label ▶ Attach the duplicate label (type label) in the appropriate place in the engine compartment 	
--------------------	--	--

6 Installation overview

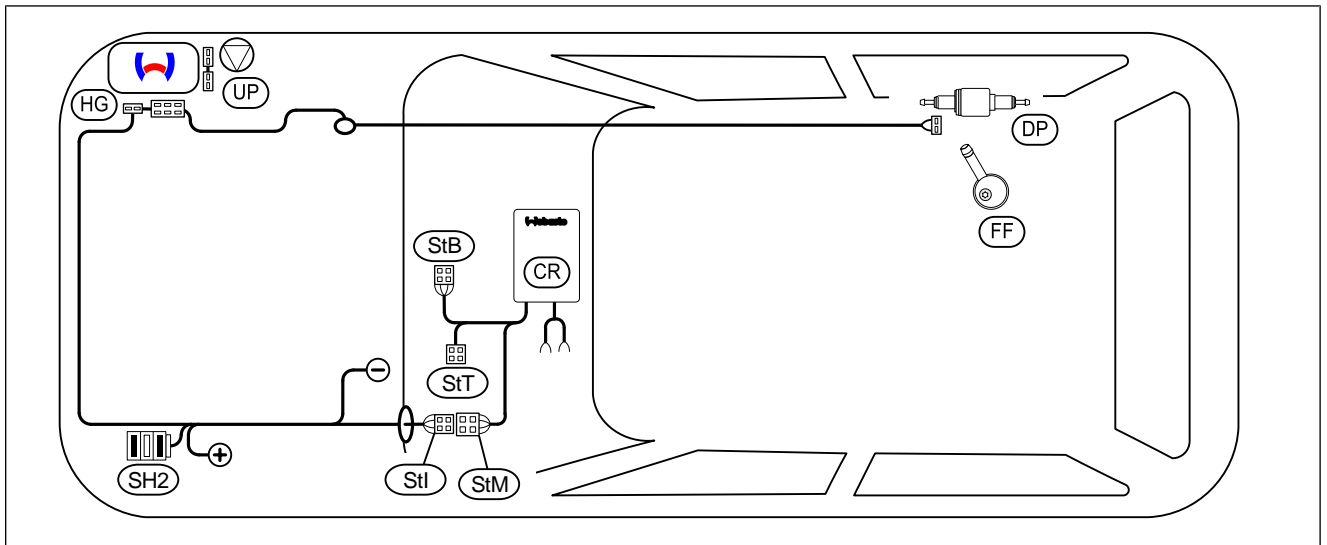
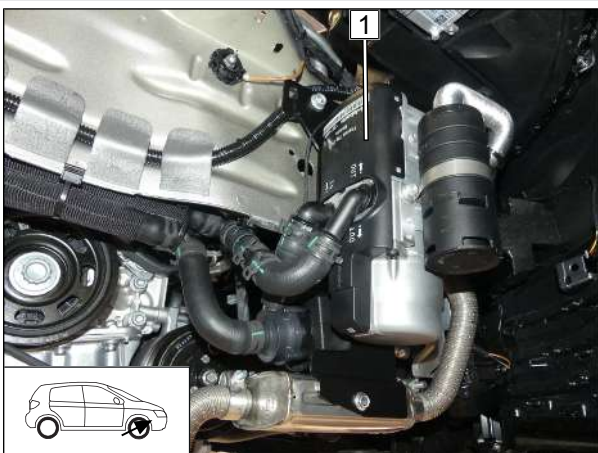

Fig. 1

Legend to installation overview

Abbreviation	Component
CR	Cronus (passenger compartment control unit)
DP	Fuel pump
FF	FuelFix
HG	Heater assembly
SH2	Engine compartment fuse holder for F1/F2/F3
StB	Female plug for control element wiring harness
StI	Female plug for passenger compartment wiring harness
StM	Male plug for engine compartment wiring harness
StT	Male plug for push button wiring harness
UP	Coolant pump

Heater assembly installation location



1 Heater assembly

Fig. 2



7 Electrical system of engine compartment

Removing cover

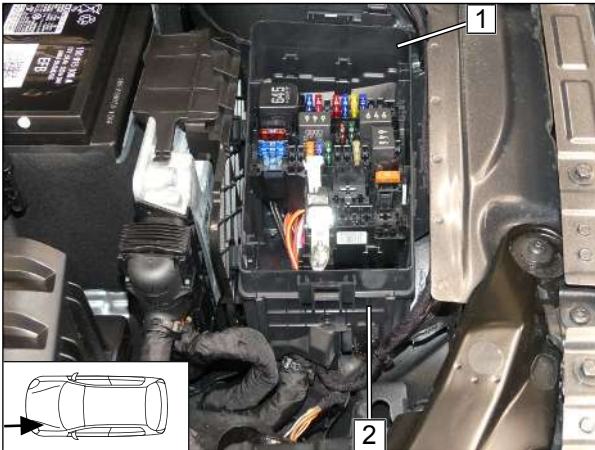

Fig. 3

- ▶ Remove front cover **2** of engine compartment fuse and relay box **1**.

Copying hole pattern, drilling hole

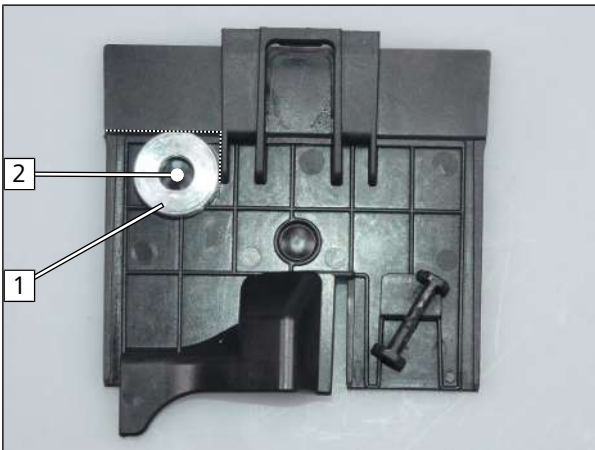

Fig. 4

- ▶ Position 5 mm spacer **1** on front cover, copy hole pattern **2** and drill $\text{\O}6$ hole.

Premounting retaining plate of SH2

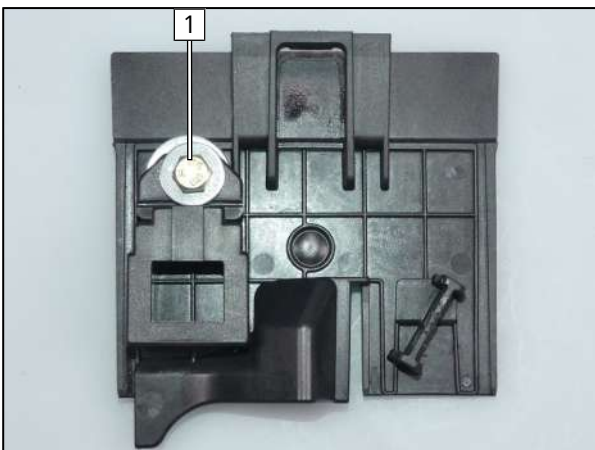

Fig. 5

- 1** M5x20 bolt, large diameter washer, SH2 retaining plate, spacer (5), front cover, retaining plate, nut



Preparing wiring harness

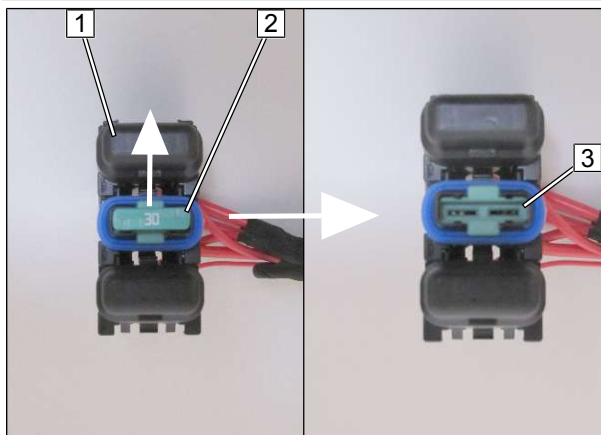

Fig. 6

Remove and discard 30A fuse **2** from SH2 **1**.

3 Fuse removed

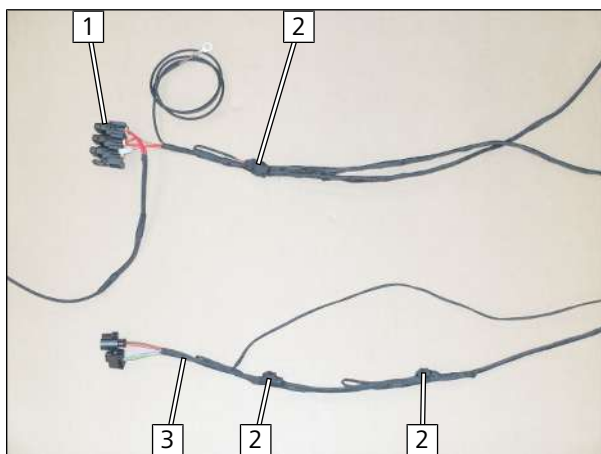

Fig. 7

Tie back connector **2** using insulating tape.

1 SH2

3 Heater wiring harness

Mounting cover and SH2



Fig. 8

1 Front cover

2 SH2 with F1, F2 (empty) and F3



Routing wiring harnesses

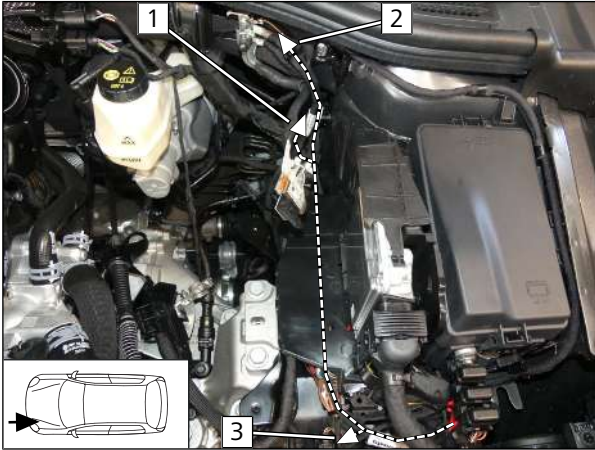

Fig. 9

- 1 Passenger compartment wiring harness
- 2 Earth wire
- 3 Heater wiring harness

Earth wire connection

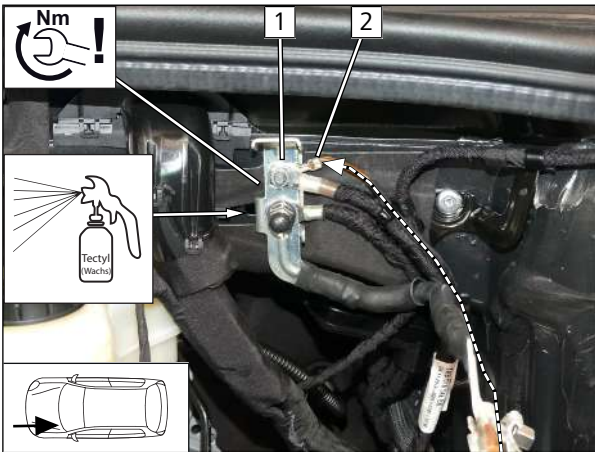

Fig. 10



DANGER

Observe tightening torque

- 1 Original vehicle earth point
- 2 Earth wire

Passenger compartment wiring harness pass through

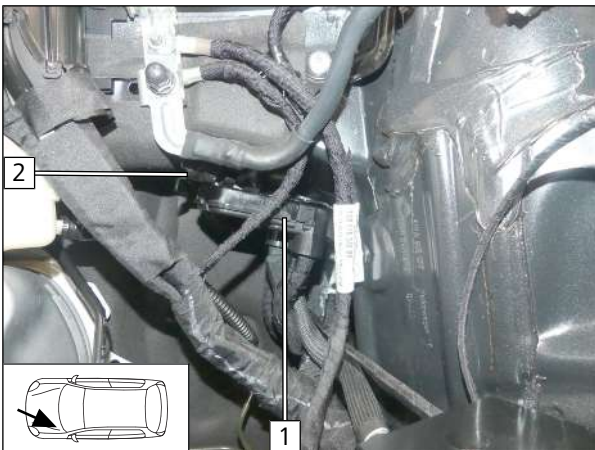

Fig. 11

- Remove positive distributor 1 from bracket 2.

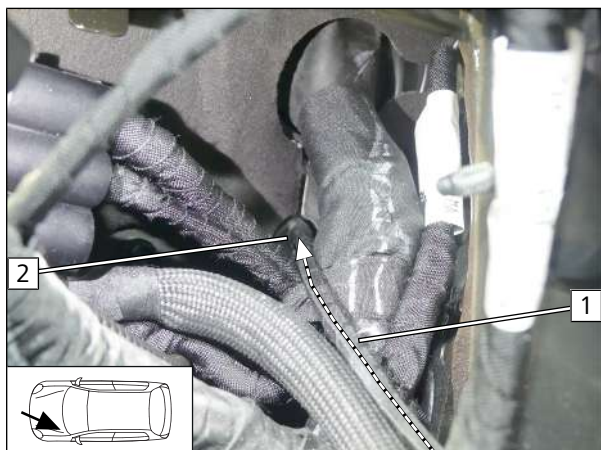

Fig. 12



To prevent water seeping into the passenger compartment, the wiring harness must be routed upwards to the protective rubber plug and this plug must then be sealed with a suitable sealing compound.

- 1 Passenger compartment wiring harness
- 2 Pass through in protective rubber plug (open using suitable means)

Heater wiring harness routing

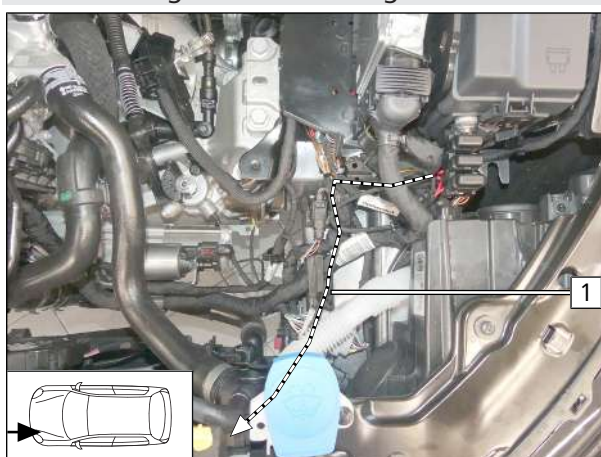

Fig. 13

- 1 Heater wiring harness

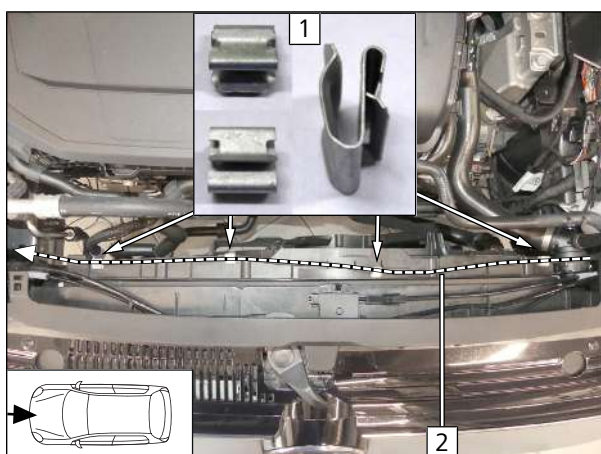

Fig. 14

- 1 Edge clip
- 2 Heater wiring harness

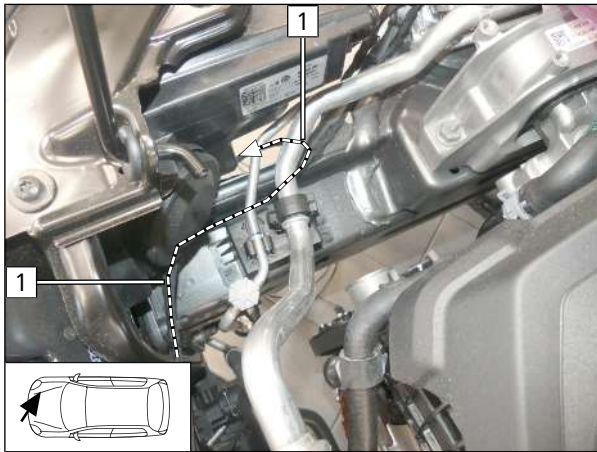

Fig. 15

- 1 Heater wiring harness

Positive wire connection

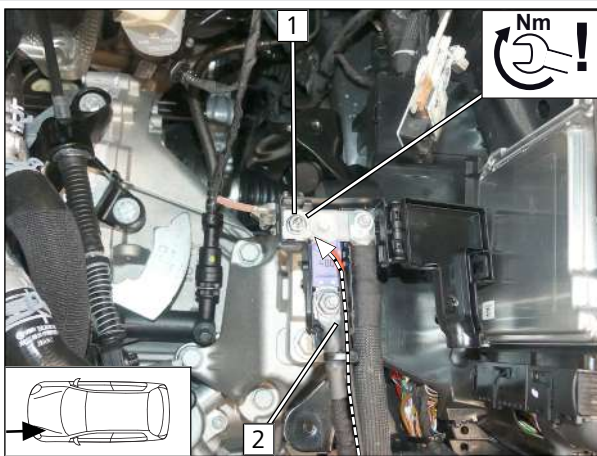

Fig. 16



DANGER

Observe tightening torque

- 1 Original vehicle positive point
- 2 Positive wire



8 Mechanical system

8.1 Installation location preparation

Loosening original vehicle wiring harness

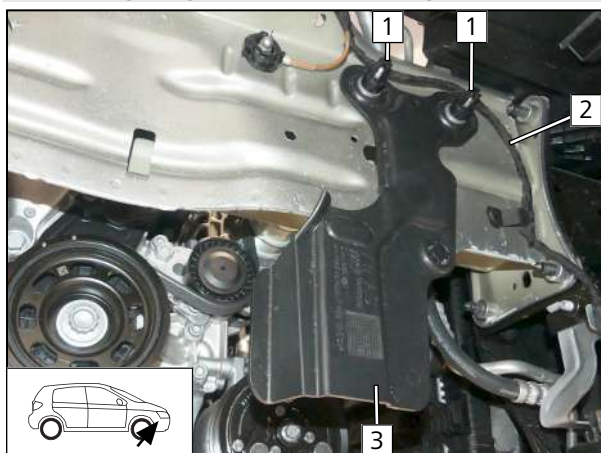

Fig. 17

- ▶ Remove and discard original vehicle wiring harness bracket **1**.
- ▶ Original vehicle wiring harness **2**
- ▶ Remove and discard deflector (if present) **3**

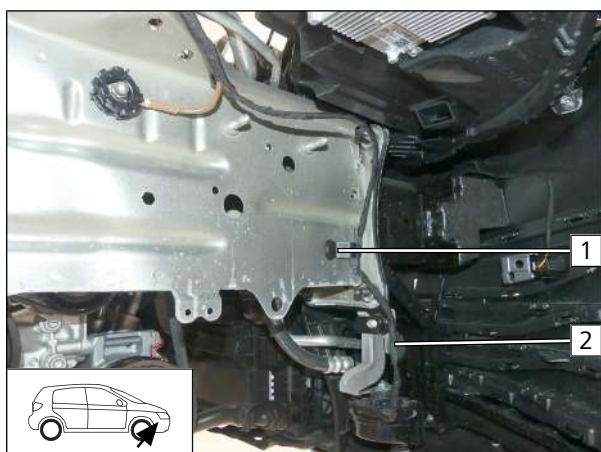

Fig. 18

- ▶ Remove and discard original vehicle wiring harness bracket **1**.
- ▶ Detach original vehicle wiring harness **2** from bracket.

Adapting original vehicle tab

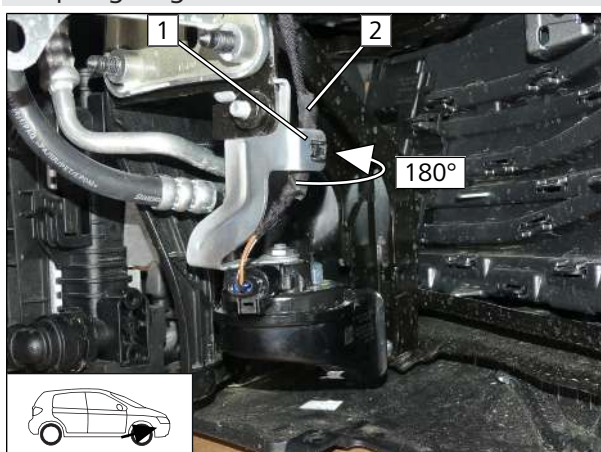

Fig. 19

- ▶ Bend original vehicle tab **1** as shown. Mount original vehicle wiring harness **2** as shown.



Aligning horn



Fig. 20



Danger of damage to components

► Ensure sufficient distance from neighbouring components, correct if necessary.

- Unscrew nut **1** of horn **2**.
- Align horn **2** as shown and tighten nut **1**.
- Align bracket **3** with the driving direction.

Routing original vehicle wiring harness

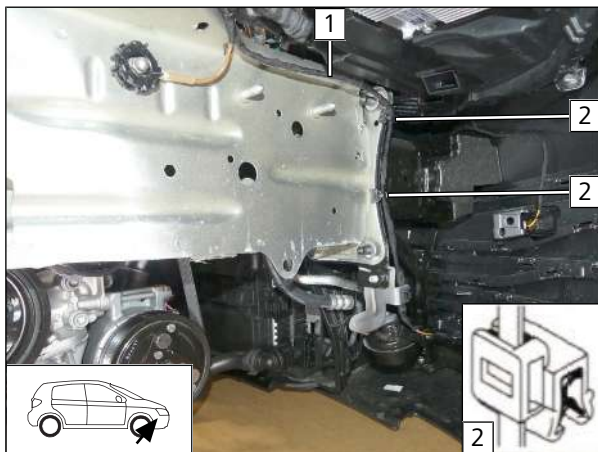

Fig. 21

1 Original vehicle wiring harness

2 Edge clip cable tie

Aligning original vehicle tab

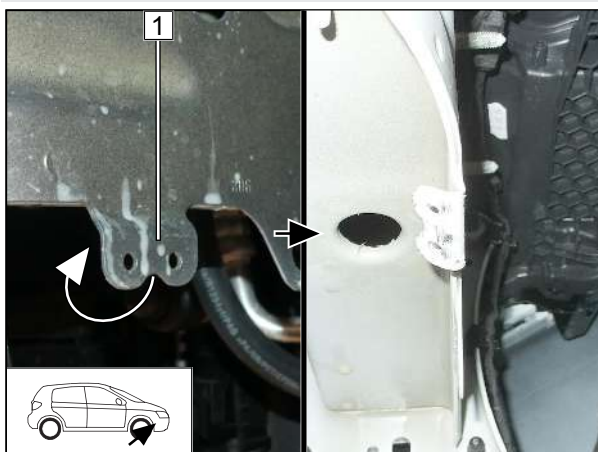

Fig. 22

- Bend original vehicle tab **1** as shown.



Positioning spacer

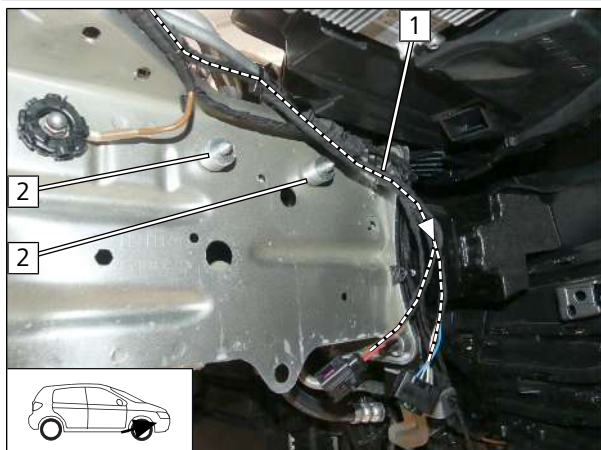

Fig. 23

- 1 Heater wiring harness
- 2 10mm spacer and 5mm spacer on original vehicle stud bolt

8.2 Heater assembly installation

View of heater assembly



Fig. 24

- 1 Heater inlet connection
- 2 Heater outlet connection
- 3 Fuel line

Assigning heater assembly hoses

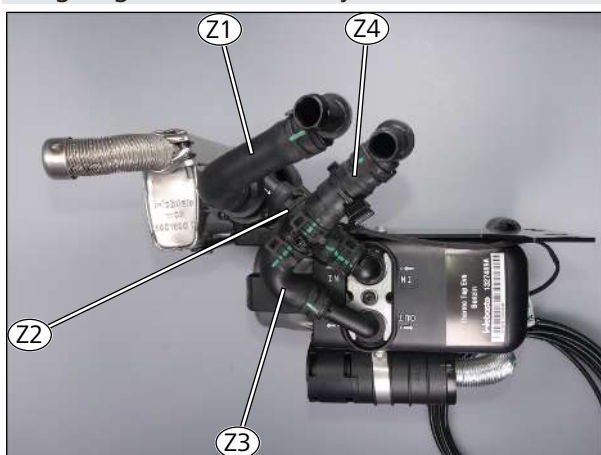

Fig. 25

- Z1 Coolant pump inlet hose section
- Z2 Coolant pump outlet/heater inlet hose section
- Z3 Heater outlet hose section
- Z4 Hose section on hose (Z3) (heater outlet)



Mounting HG wiring harness

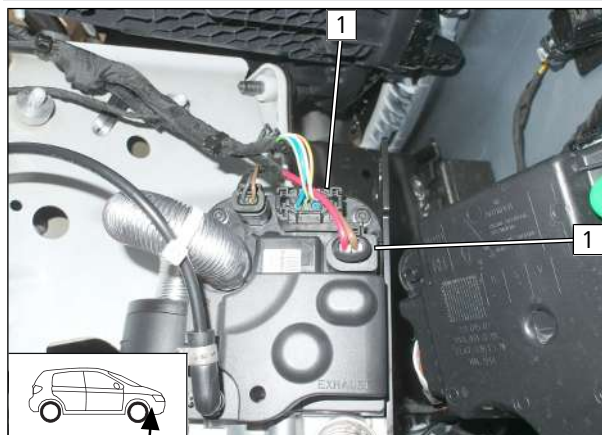

Fig. 26

- 1 Heater wiring harness connector

Heater assembly installation

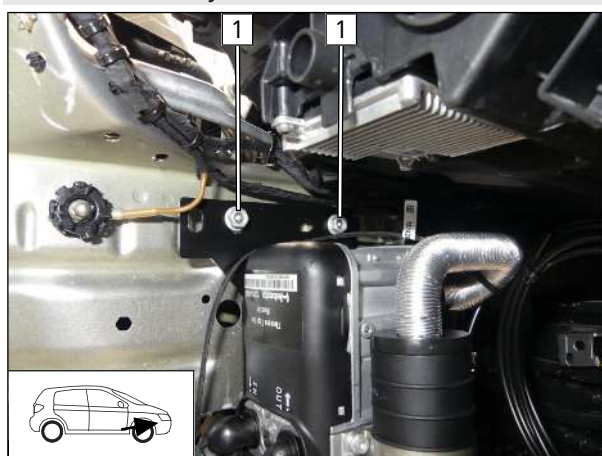

Fig. 27

- Mount flanged nut 1 loosely.

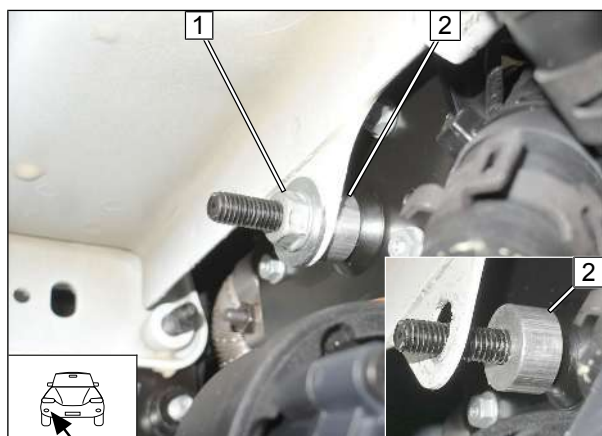
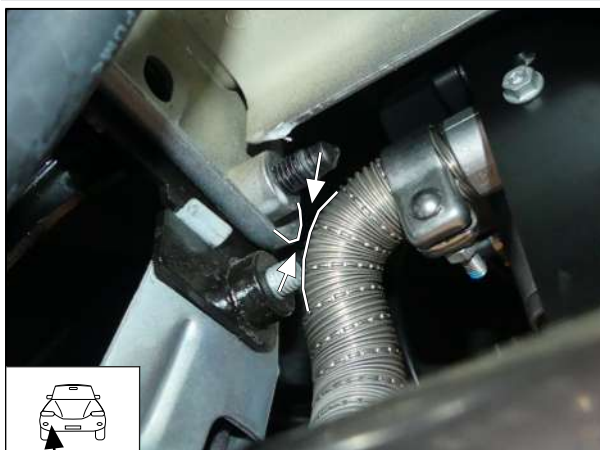

Fig. 28

- 1 Mount heater bracket stud bolt, spacer (10), original vehicle tab, large diameter washer, flanged nut loosely
- 2 Spacer (10)



Checking distance



Danger of damage to components

► Ensure sufficient distance from neighbouring components, correct if necessary.



Tighten all the screw connections of the heater assembly.

Fig. 29

Fastening hose (Z4)

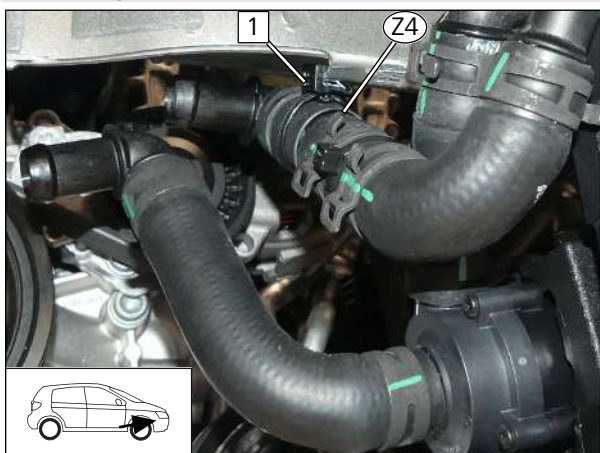

1 Edge clip cable tie

Fig. 30



9 Fuel



DANGER

Risk of fire and explosion due to leaking fuel and escaping fuel vapours.

The incorrect installation of the fuel extractor can cause damage and fire.

- ▶ Avoid electrostatic discharges and open fire
- ▶ When working on the fuel system, ensure sufficient ventilation and bleeding
- ▶ Open the fuel tank cap of the vehicle
- ▶ Ventilate the fuel tank
- ▶ Re-close the tank lock
- ▶ Catch any fuel running off with an appropriate container



Danger of damage to components

- ▶ Install fuel line and fuel pump wiring harness so that they are protected against stone impact
- ▶ Provide rub protection for fuel line and wiring harness in areas where there are sharp edges

Dismantling fuel pump connector X7

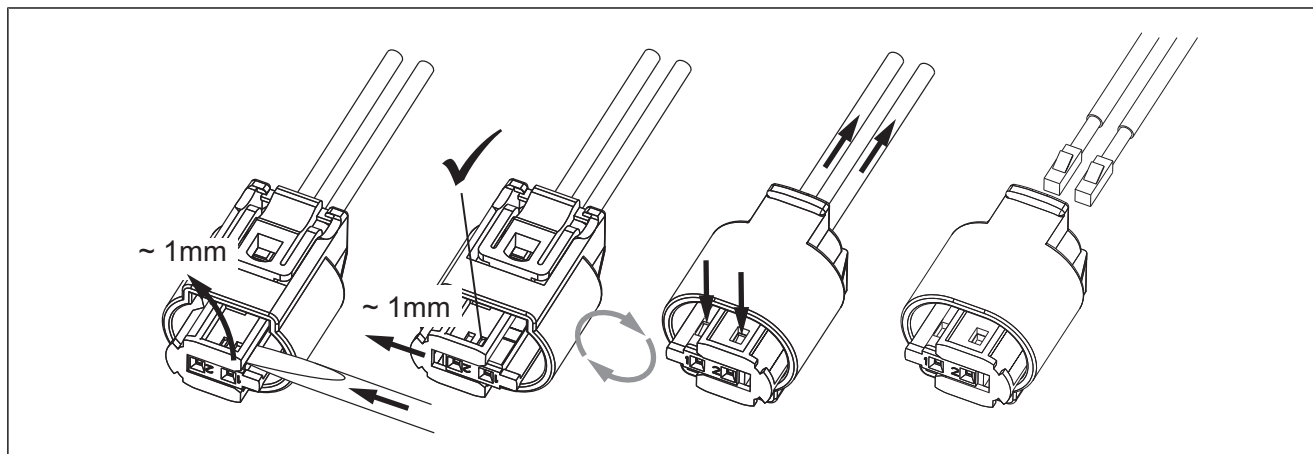

Fig. 31

9.1 Routing fuel line

Cutting to length/assigning corrugated tubes

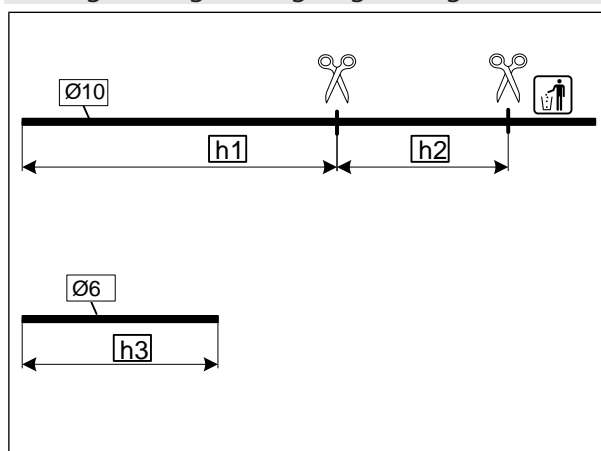

Fig. 32

h1	800
h2	120
h3	270



Routing fuel line in wheel well



Fig. 33

- 1 Fuel line and fuel pump wiring harness in corrugated tube **h1**
- 2 Cable tie

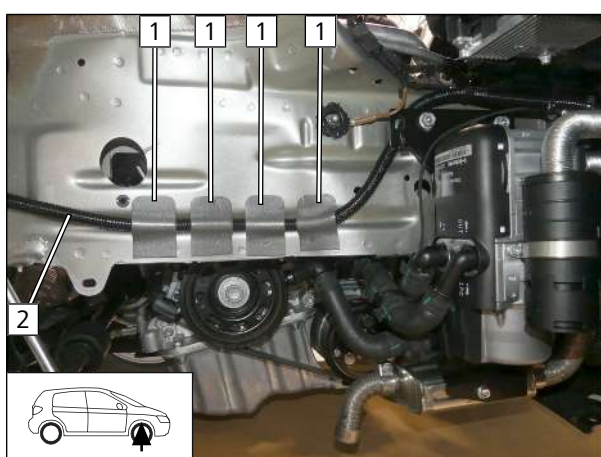

Fig. 34

- 1 Self-adhesive foam cut in half
- 2 Fuel line and fuel pump wiring harness in corrugated tube **h1**

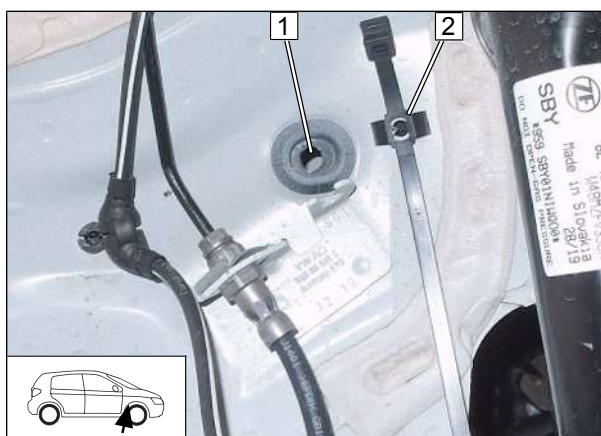

Fig. 35

► Pierce original vehicle pass through **1** in the middle as shown.

- 2 Eyelet cable tie in original vehicle hole

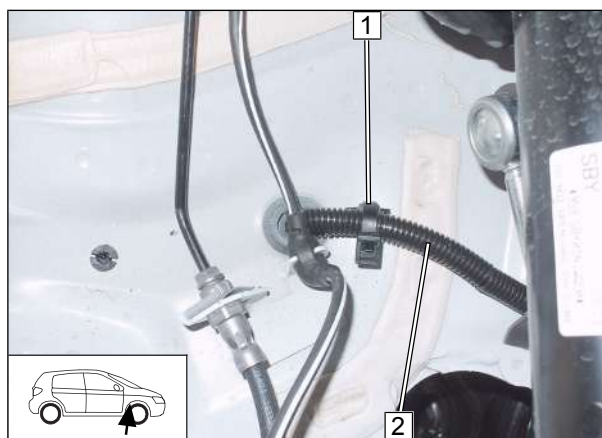

Fig. 36

- 1 Close eyelet cable tie
- 2 Fuel line and fuel pump wiring harness in corrugated tube **h1**

Preparing fuel pump installation location

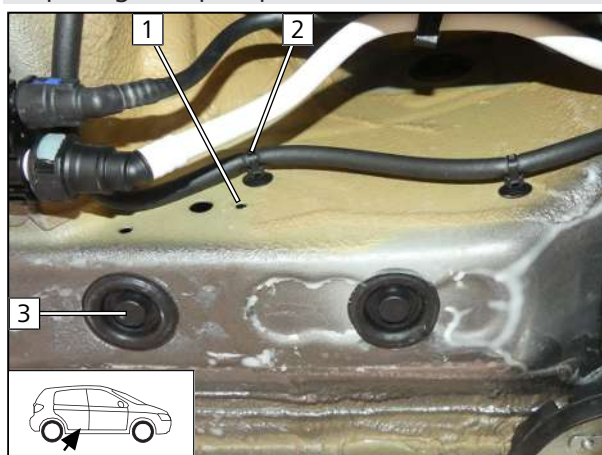

Fig. 37

- Move clip-type cable tie from position 1 to position 2. Remove sealing plug 3.

Premounting bolts

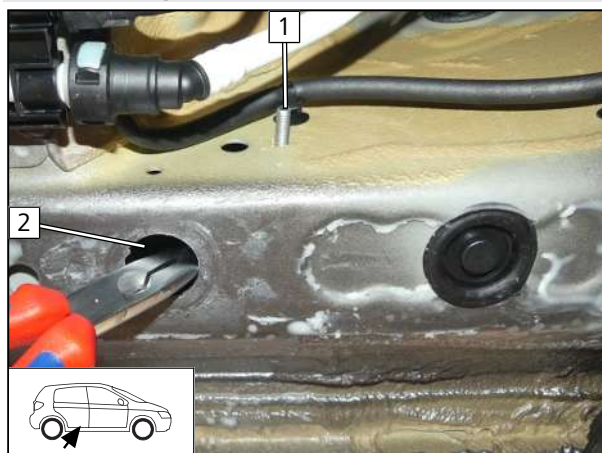

Fig. 38

- 1 M6x20 bolt
- 2 Assembly opening

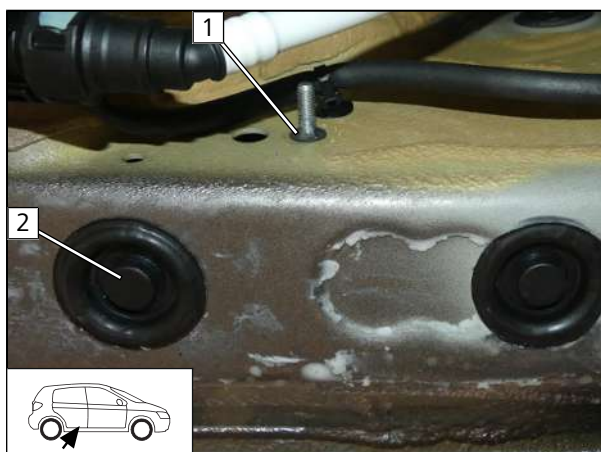

Fig. 39

- 1 Lock washer
- 2 Sealing plug, mounted

Premounting fuel pump

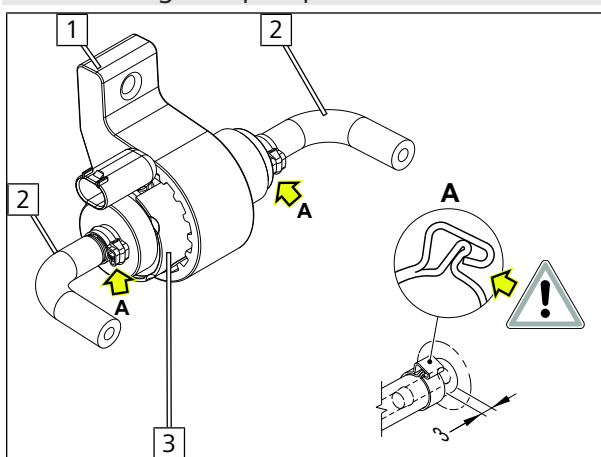



Fig. 40

 The alignment of the fuel pump and fuel hoses will be carried out afterwards, during the installation.

- 1 Fuel pump mount
- 2 90° moulded hose, Ø10 clamp
- 3 Fuel pump



Fig. 41

- 1 M6x25 bolt, perforated bracket, fuel pump mount, support angle bracket, flanged nut



Assembling fuel pump connector X7

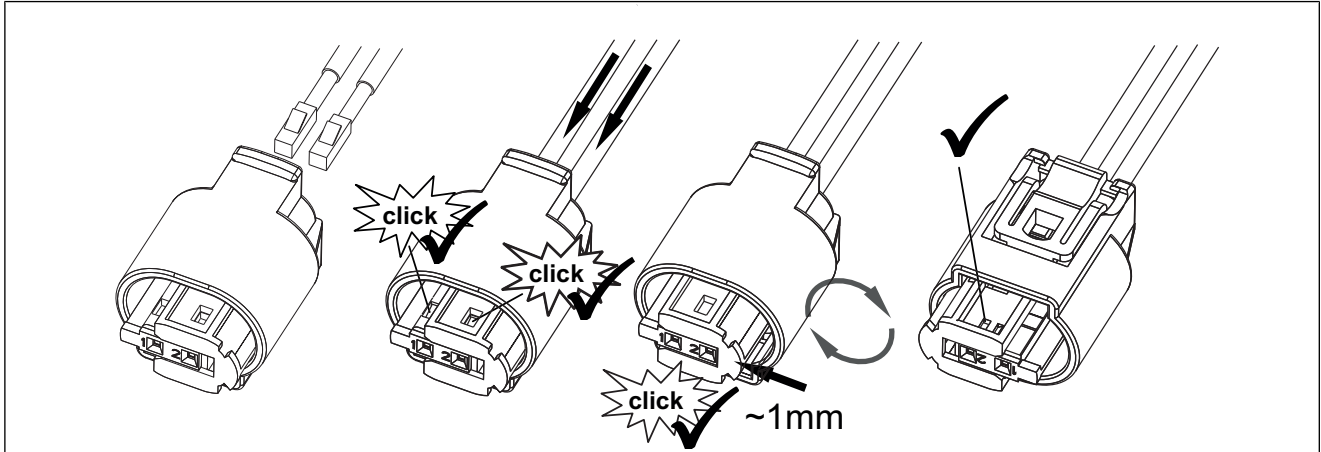

Fig. 42

Mounting and connecting fuel pump

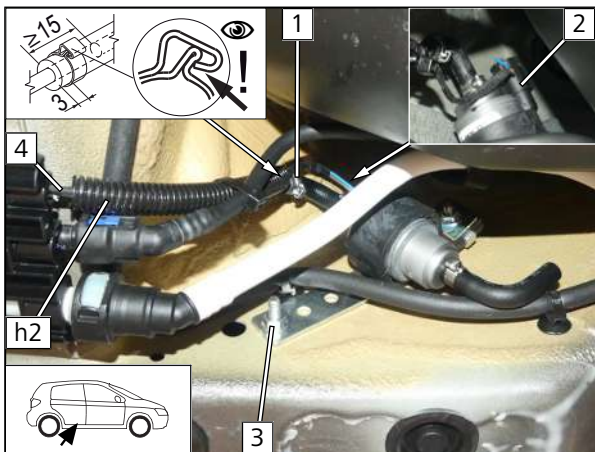

Fig. 43

- 1 Ø10 clamp
- 2 Fuel pump wiring harness, connector X7 mounted
- 3 Premounted M6x20 bolt, premounted fuel pump, flanged nut
- 4 Fuel line in corrugated tube **h2**

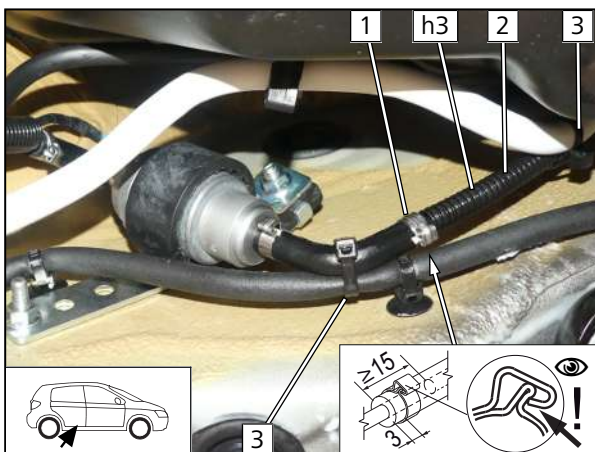

Fig. 44

- 1 Ø10 clamp
- 2 Fuel line in corrugated tube **h3**
- 3 Cable tie



9.2 Installing FuelFix

Moving label

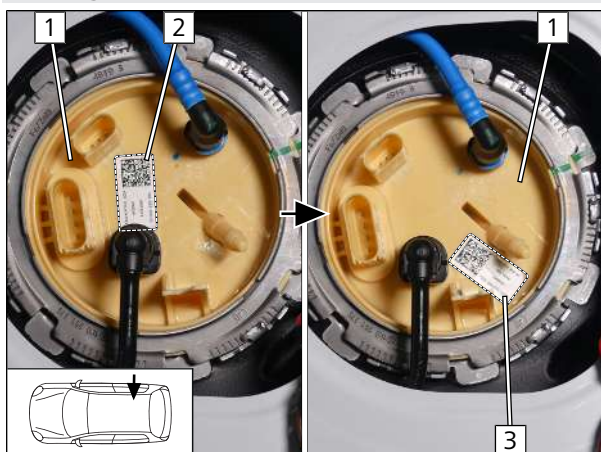

Fig. 45

- 1 Tank fitting
- 2 Original position of label
- 3 New position of label

Work steps F1, F2

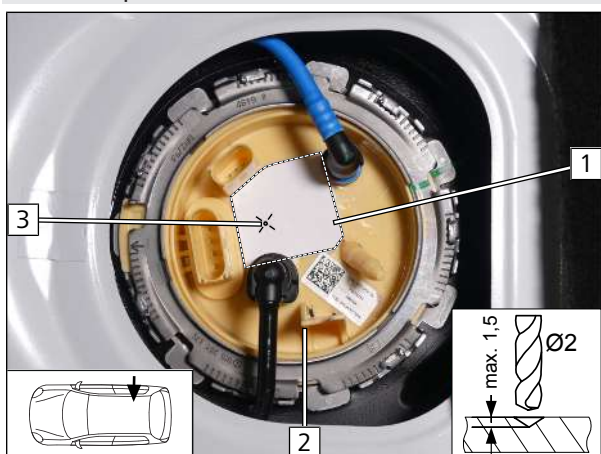

Fig. 46



Observe the installation instructions of the tank extracting device.

- ▶ Cut out provided template 1 and position as shown.
- ▶ Copy hole pattern 3 onto tank fitting 2.
- ▶ Drill Ø2 centring hole at position 3 as shown.

Work step F3

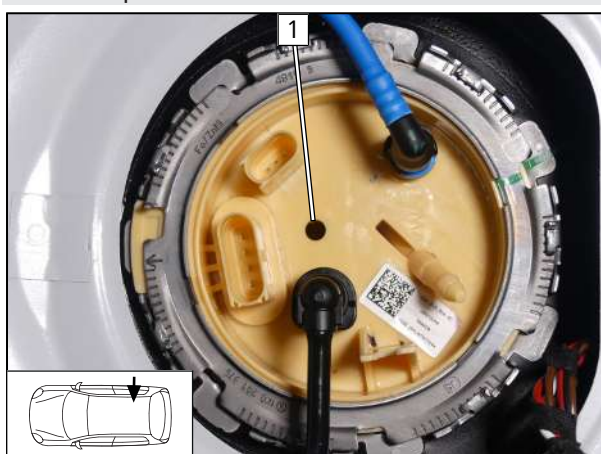

Fig. 47



DANGER

Risk of fire and explosion due to leaking fuel and escaping fuel vapours.

- 1 Hole made with provided drill



Work steps F4, F5

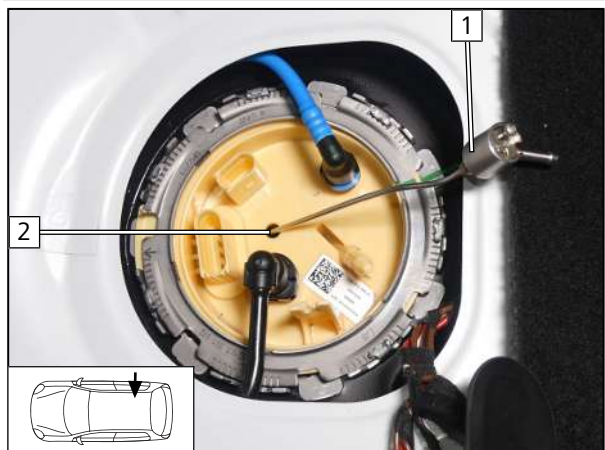

► Bend FuelFix **1** according to template and cut to length. Insert in hole **2**.

Fig. 48

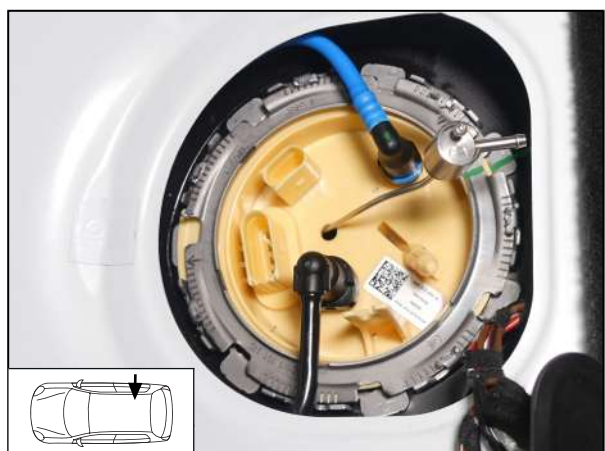

Fig. 49



Fig. 50

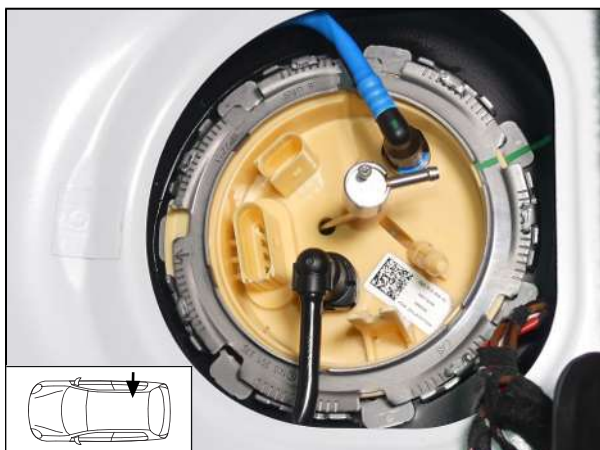

Fig. 51

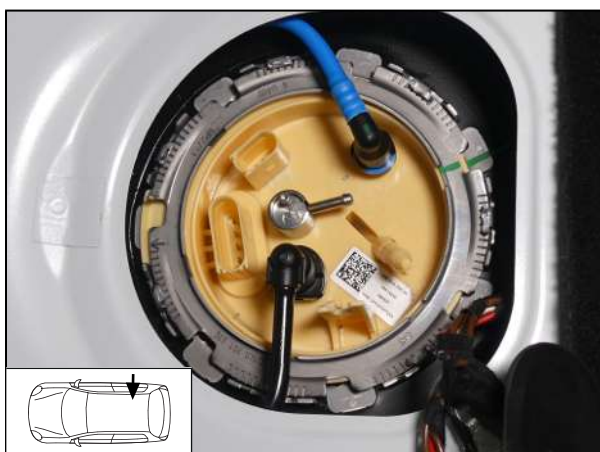

Fig. 52

Work steps F5.3, F5.4

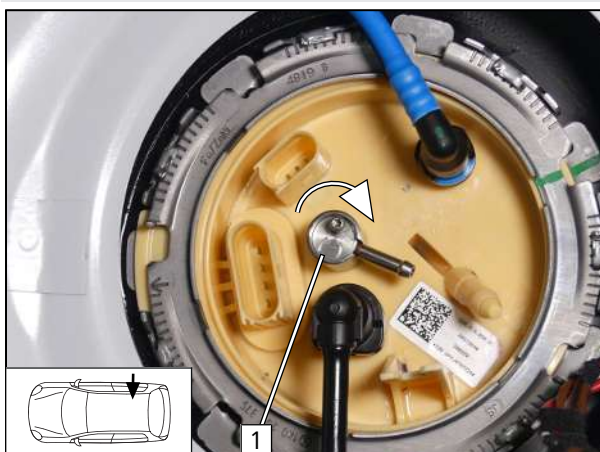

Fig. 53

► Align FuelFix **1** as shown.



Work step F6

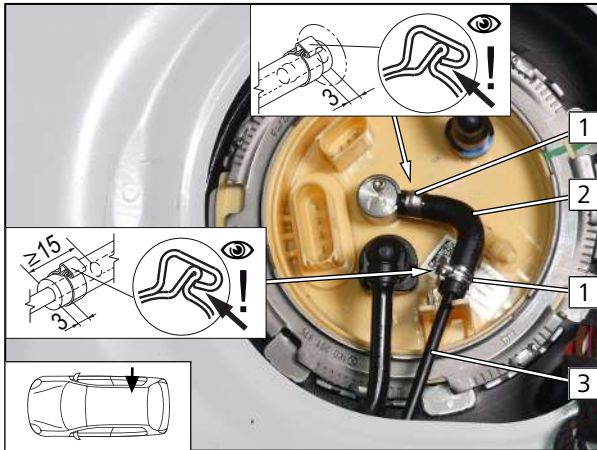

Fig. 54

- 1 10mm dia. clamp [2x]
- 2 90° moulded hose
- 3 Fuel line of FuelFix

Work step F7

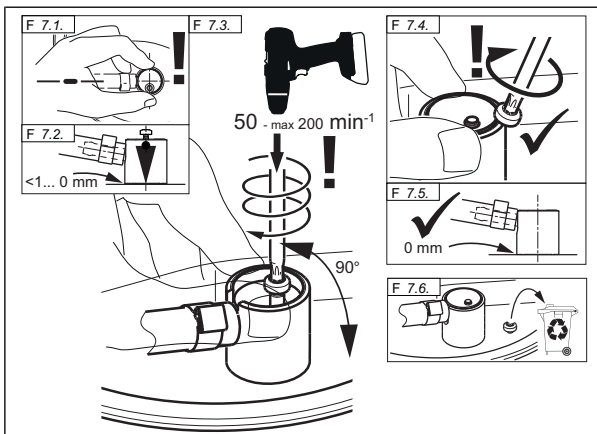

Fig. 55



DANGER

Risk of fire and explosion due to leaking fuel and escaping fuel vapours.

Work step F8



Fig. 56



Securing fuel line

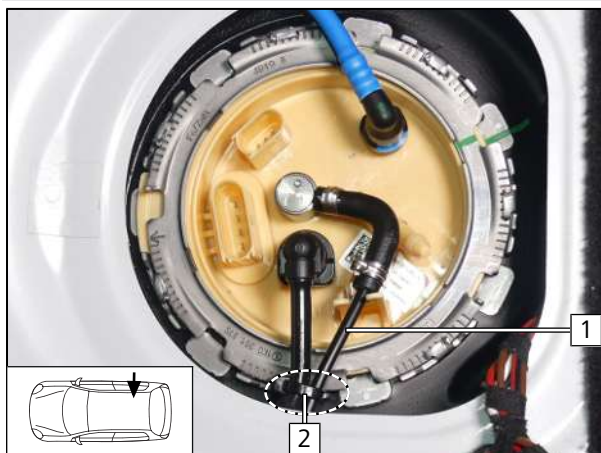

► Secure fuel line **1** with cable tie **2** for tension relief.

Fig. 57



10 Coolant

10.1 Preliminary work on vehicle

Shortening and mounting hose section

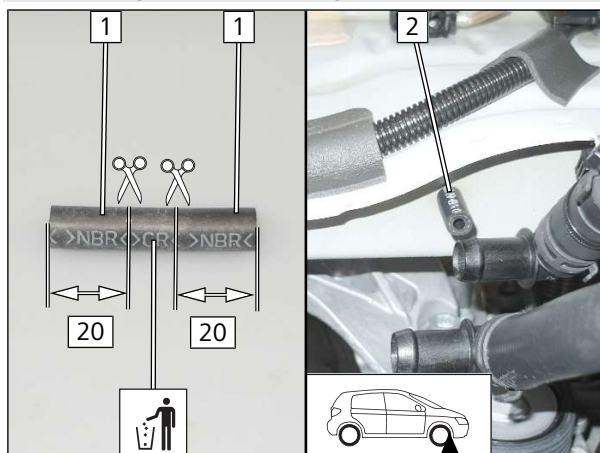

Fig. 58

- 1 Hose section \varnothing 4.5
- 2 Shortened hose section, original vehicle stud bolt

Perforated bracket installation

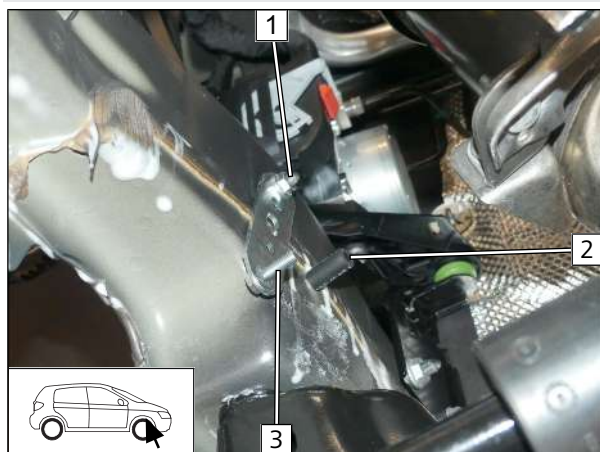

Fig. 59

- 1 Original vehicle stud bolt, perforated bracket, flanged nut
- 2 Shortened hose section
- 3 M6x20 bolt

Drilling hole

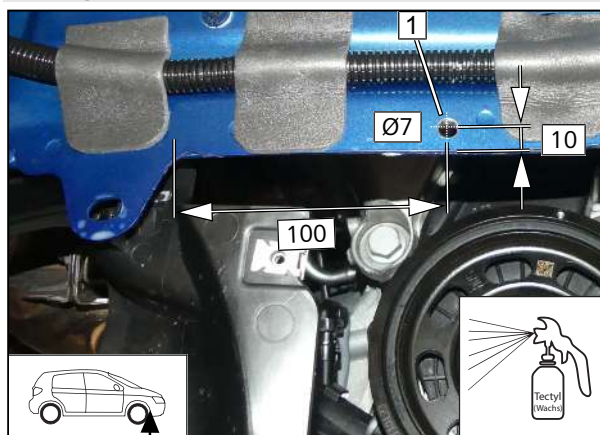

Fig. 60

- 1 Drill hole



Bending perforated bracket

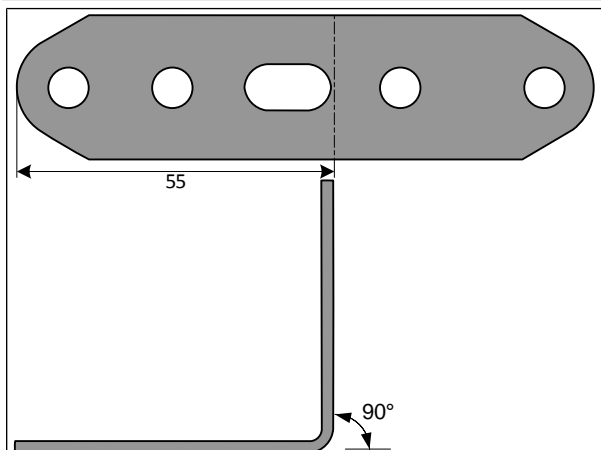

Fig. 61

Installing perforated bracket

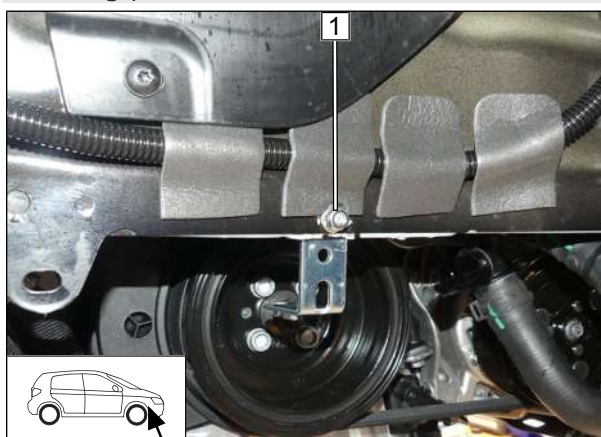

Fig. 62

- 1 M6x12 bolt, perforated bracket, drilled hole, flanged nut

Spacer nut installation

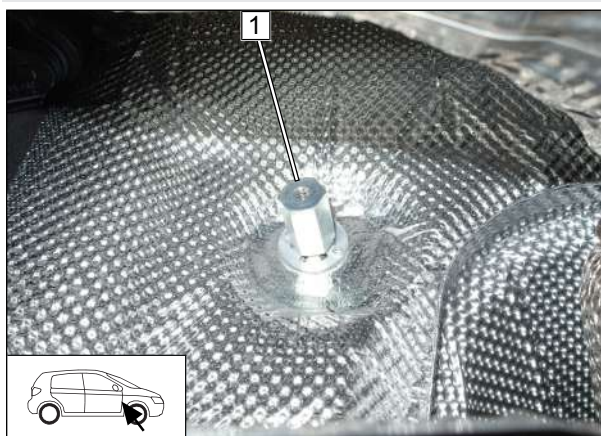
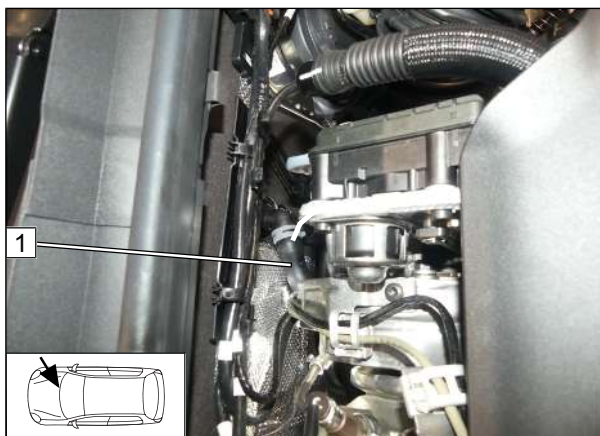

Fig. 63

- 1 M6x30 spacer nut, original vehicle stud bolt



► Remove hose of engine outlet/heat exchanger inlet **1**.

Fig. 64

10.2 Preparing hoses

Cutting hoses to length

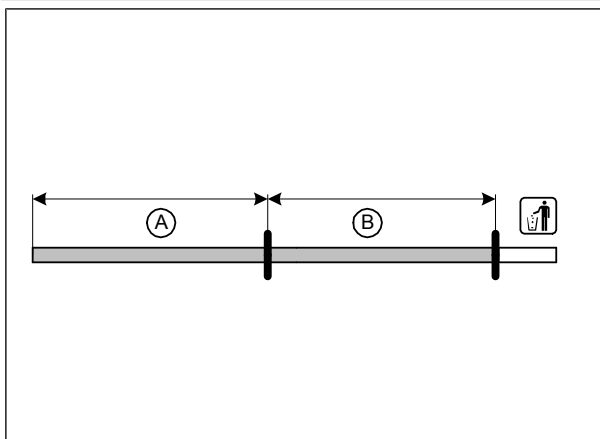

Ⓐ 900

Ⓑ 880

Fig. 65

Preparing hoses Ⓐ and Ⓑ

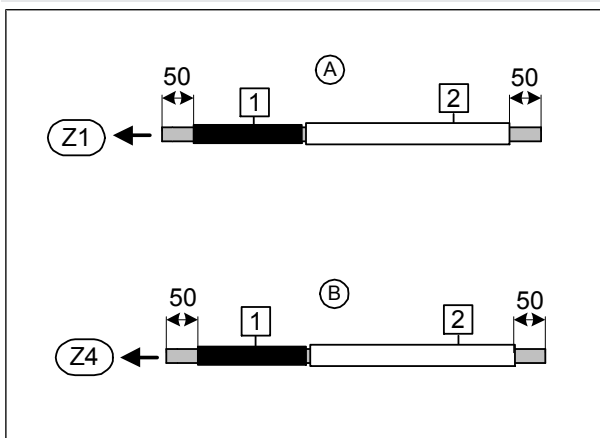

Slide on fabric heat shrink tubing **1** as shown and use 230°C at most to shrink it.

► Slide on 600 long heat protection hose **2** as shown.

Fig. 66



Cutting point



Fig. 67

- 1 Engine outlet hose section
- 2 Heat exchanger inlet hose section

Preparing hose section

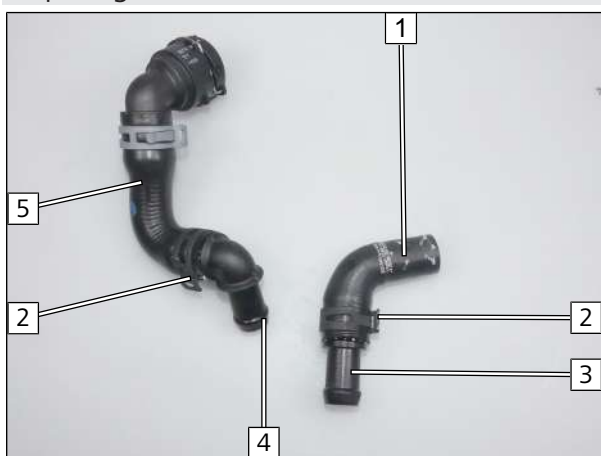

Fig. 68

- 1 Engine outlet hose section
- 2 Ø25 spring clip
- 3 Ø18/20 connecting pipe
- 4 Ø18x20, 90° connecting pipe
- 5 Heat exchanger inlet hose section

Preparing hoses **A** and **B**

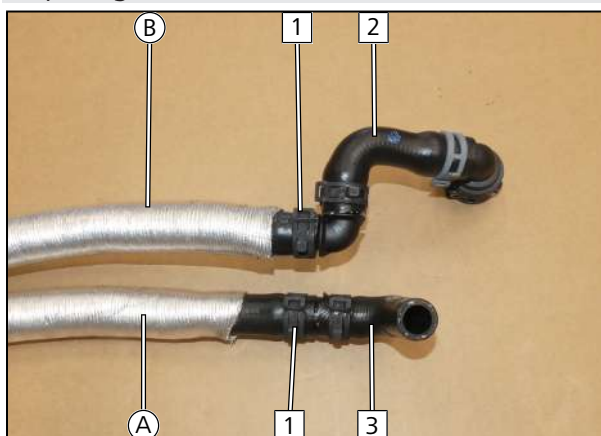

Fig. 69

- 1 Heat exchanger inlet hose section
- 2 Engine outlet hose section



10.3 Hose routing diagram

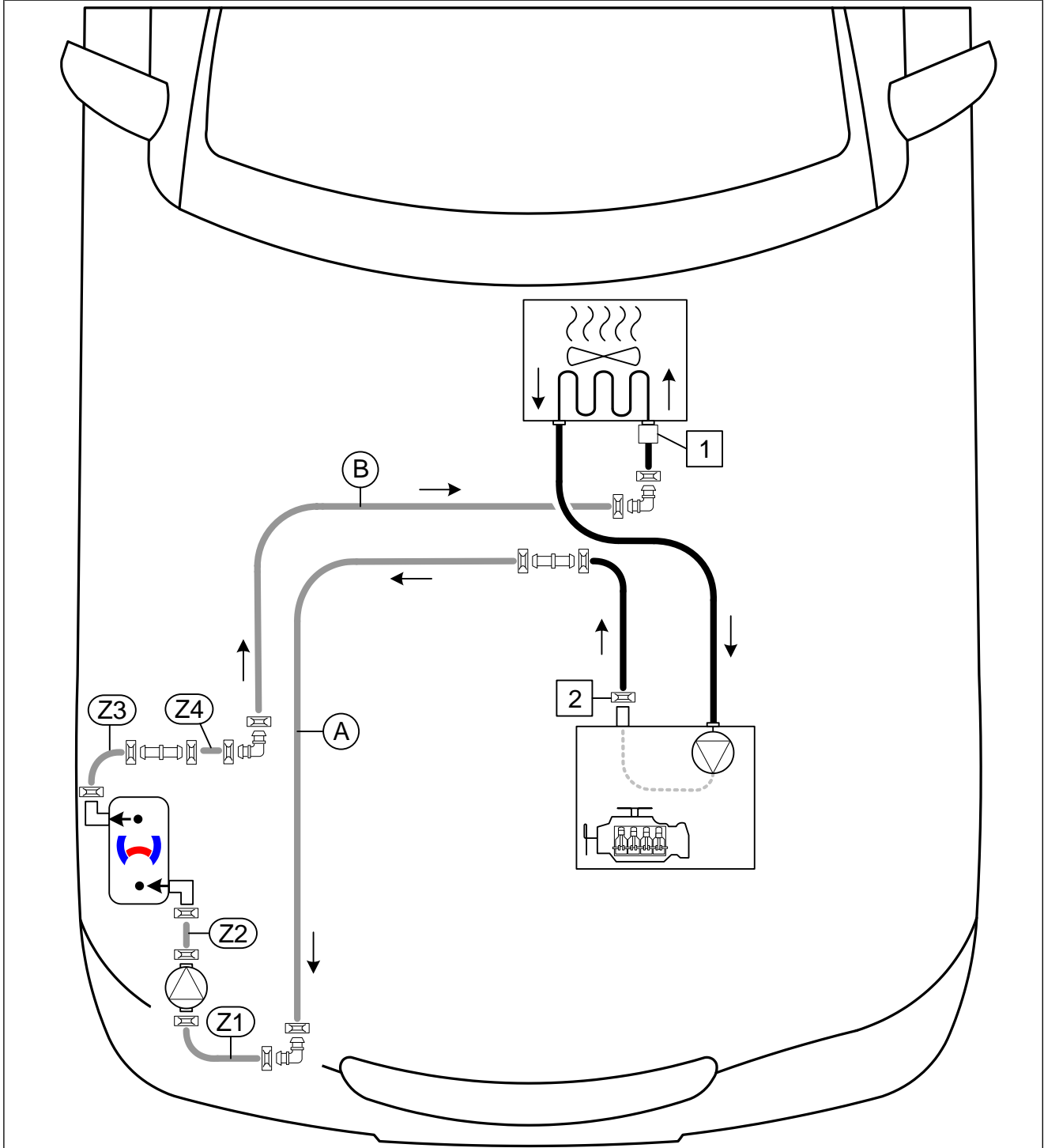

Fig. 70

All spring clips without a specific designation  = Ø25;

All connecting pipes without a specific designation  and  = Ø18x18

1 Original vehicle spring clip



10.4 Coolant circuit installation

Heat exchanger inlet connection

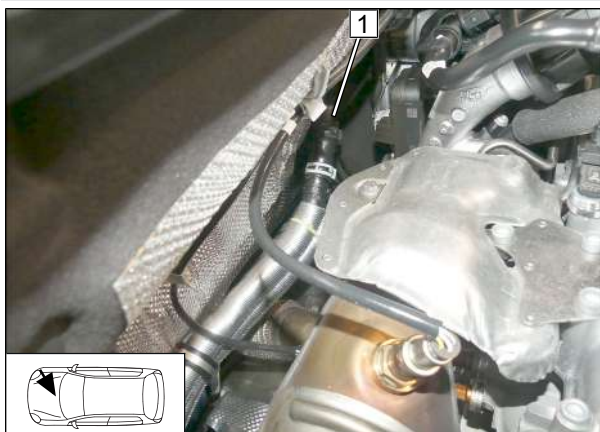

Fig. 71

- 1 Heat exchanger inlet hose section with coupling piece

Engine outlet connection

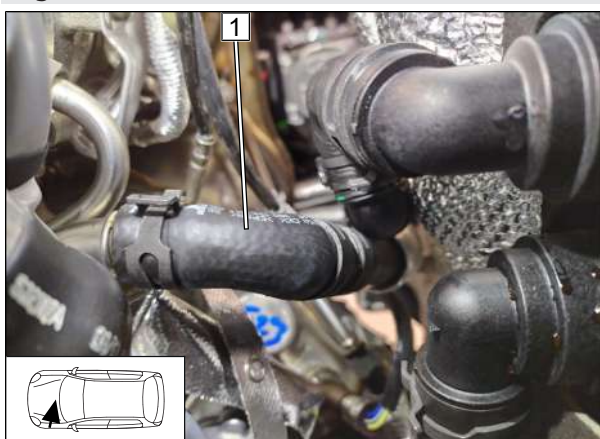

Fig. 72

- 1 Engine outlet hose section

Installing cable tie



Fig. 73

- Fix hoses **(A)** and **(B)** with white cable tie.



Routing hoses **(A)** and **(B)**

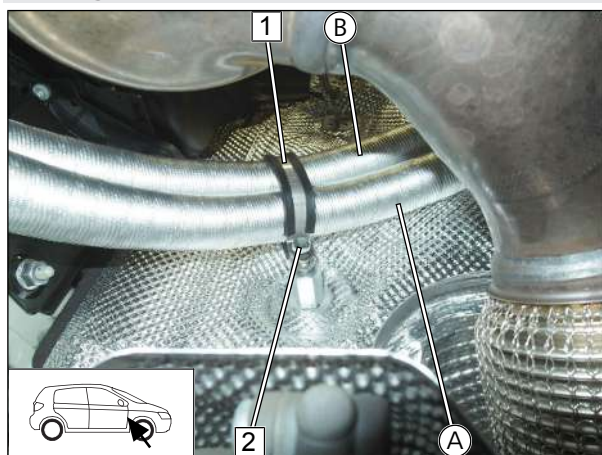

Fig. 74

- 1 Ø48 rubber-coated p-clamp
- 2 Mount M6x16 bolt, spring lock washer, rubber-coated p-clamp, loosely

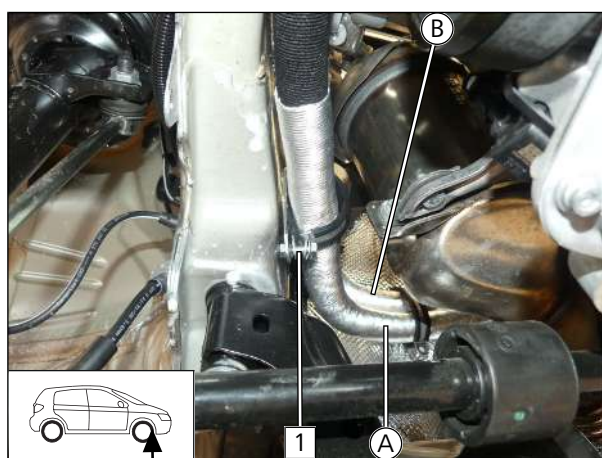

Fig. 75

- 1 M6x20 bolt, perforated bracket, 48mm dia. rubber-coated p-clamp, mount flanged nut loosely

Connecting hoses **(B)** and **(Z4)**

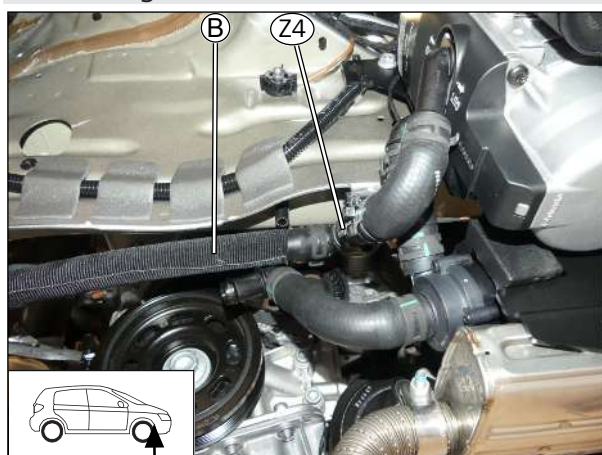

Fig. 76



Connecting hoses **A** and **Z1**

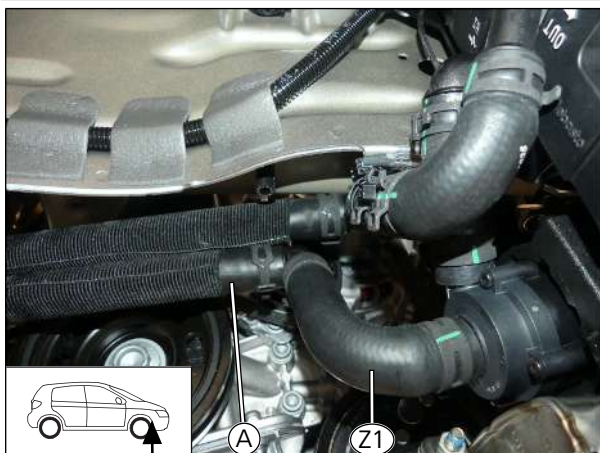

Fig. 77

Fastening hoses **A** and **B**

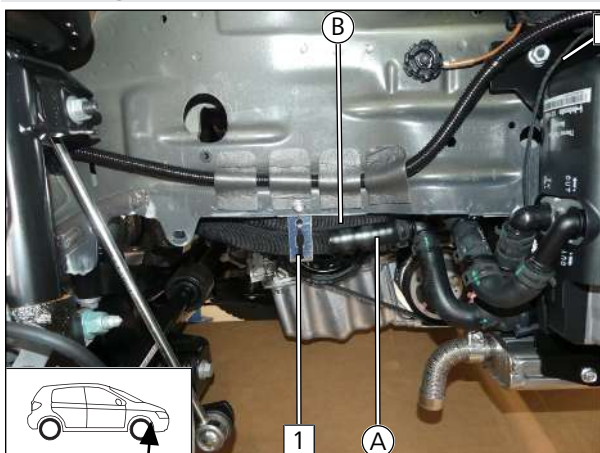

Fig. 78

- 1** Cable tie
- 2** Cable tie

Tightening all loose screw connections



Fig. 79



Tighten all loose screw connection of rubber-coated p-clamps **1**.



11 Final work

Adapting engine underide protection

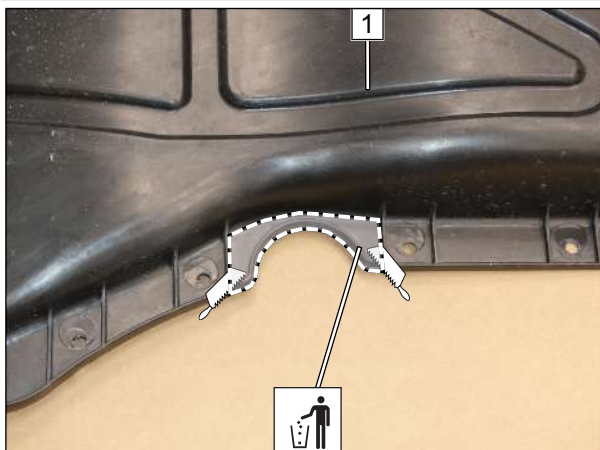

Fig. 80

1 Engine underide protection

Preparing wheel-well inner panel

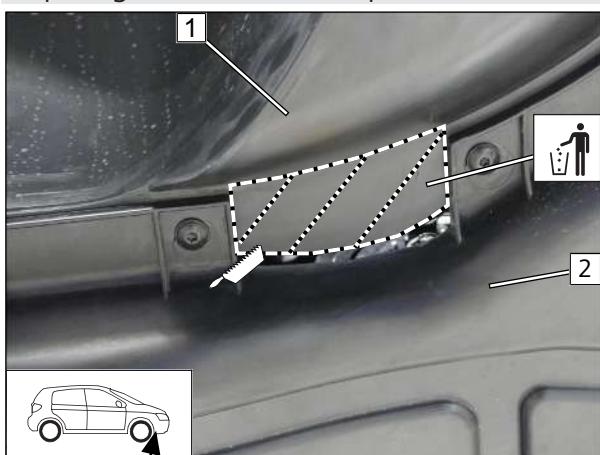

Fig. 81

- ▶ Mount wheel-well inner panel 1.
- ▶ Mount engine underide protection 2.
- ▶ Mark wheel-well inner panel 1 as shown, dismantle and cut.

Checking wheel-well inner panel distance

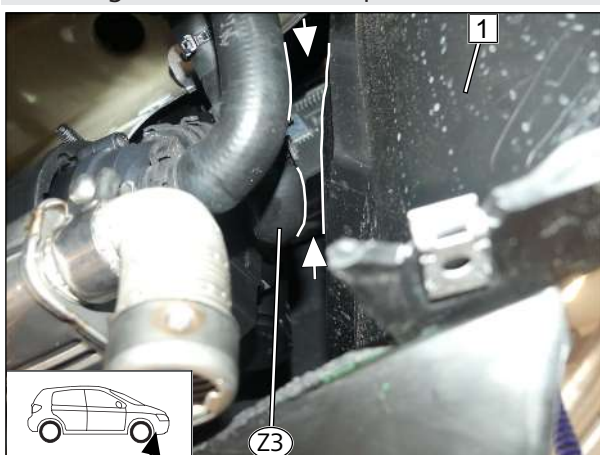

Fig. 82

- ▶ Mount wheel-well inner panel 1.



Ensure sufficient distance from neighbouring components, correct if necessary.





Aligning exhaust pipe **a2**

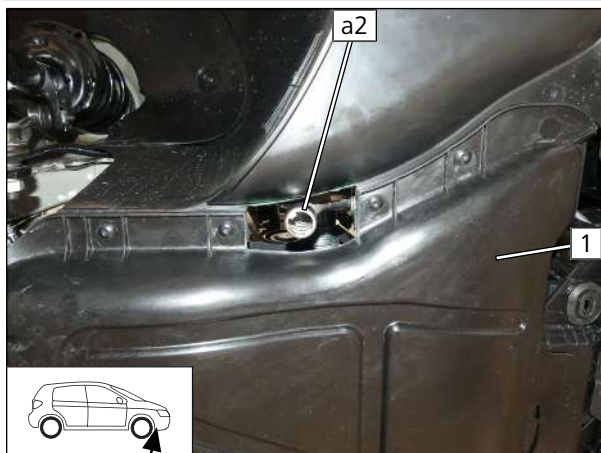

- Mount underide protection **1** and align exhaust pipe **a2** with the centre of the pass through.

Fig. 83



12 Electrical system of passenger compartment

12.1 Dismantling Instructions

- ▶ Trim strip **1**, trim strip with air distribution flap **2** (two parts, do not separate)



Fig. 84

- ▶ Original vehicle bolt **1**, glove box **2**

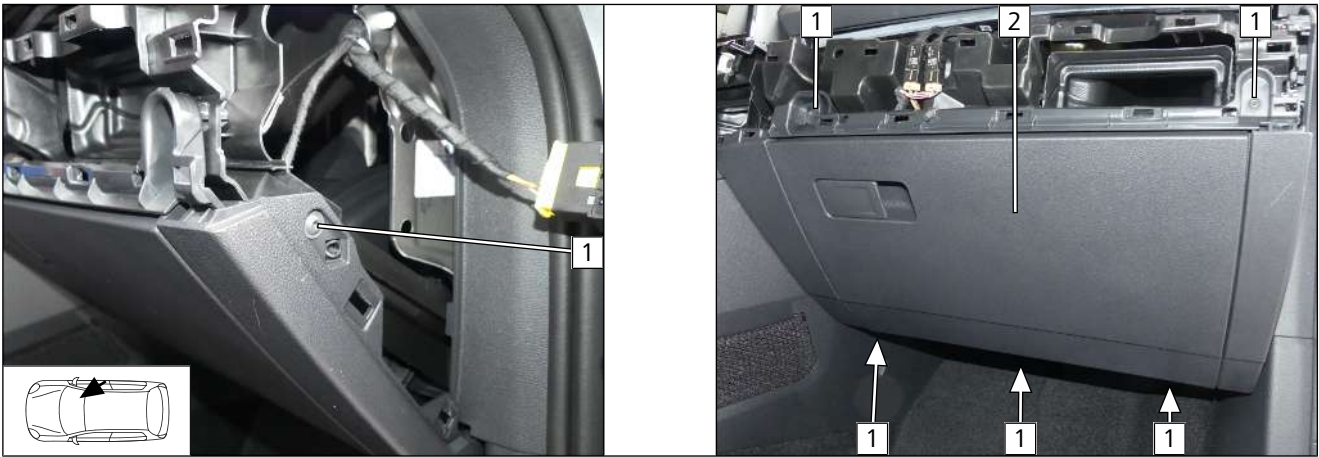

Fig. 85

- ▶ Pull rubber-coated storage compartment **1**, charging station **2** upwards to remove



Fig. 86



► Lift trim **1** and detach, clamp **2** (SG only)



Fig. 87

► Pull out trim piece **1**, bolts **2**



Fig. 88

► Original vehicle bolt **1**, connector **2**, air outlet **3**



Fig. 89



► Original vehicle bolt **1**

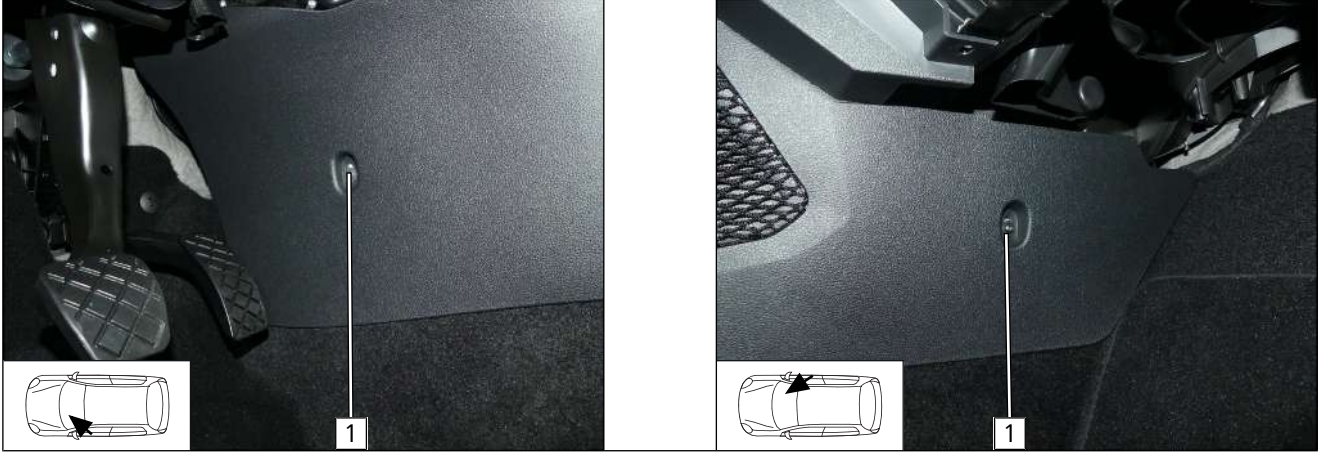

Fig. 90

► Pull off air duct **1**, original vehicle bolt **2**



Fig. 91

► Original vehicle bolt **1**



Fig. 92



► Trim **1**, original vehicle bolt **2**

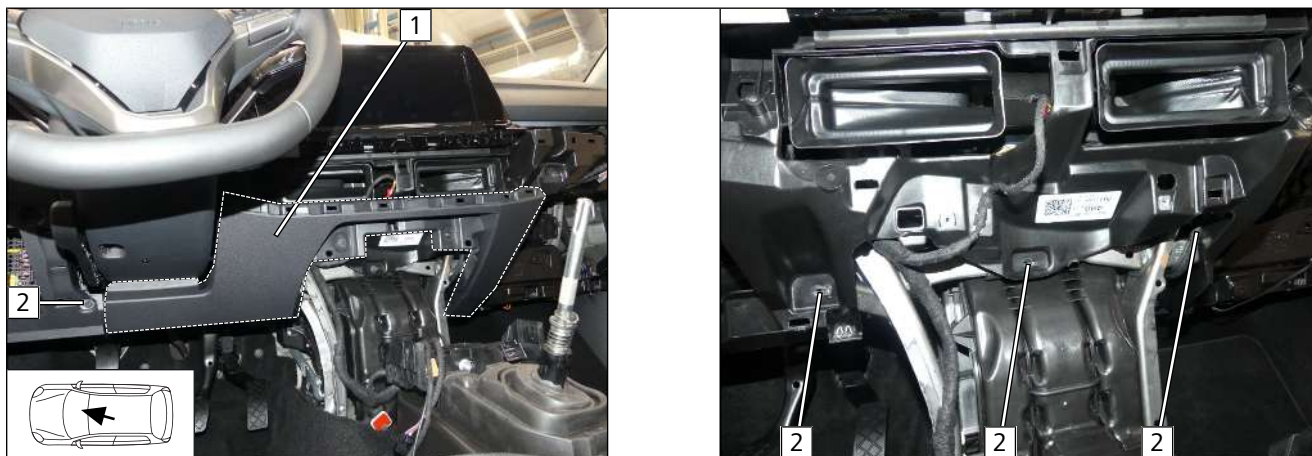

Fig. 93

► Original vehicle bolt **1**, pull down Multi Media unit **2**



Fig. 94

A/C control unit bracket **1**, discard clip **2**, clip **3** (covered)

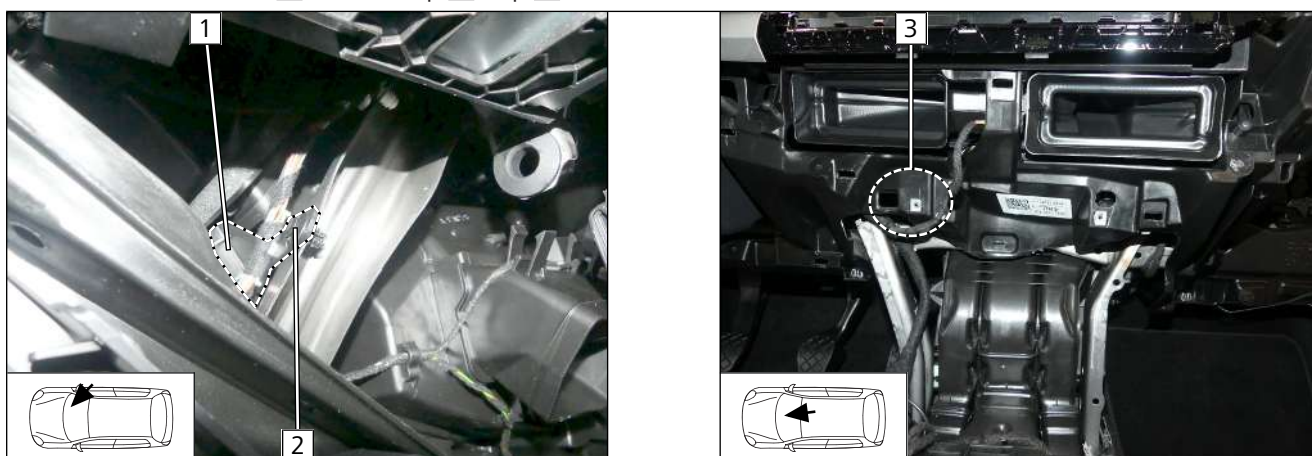

Fig. 95



Trim **1**, A/C control unit **3**, connector A **2**



At the same time lift trim **1** carefully and pull out KSG **3**.



Fig. 96



12.2 Preliminary Work

Preparing Cronus wiring harnesses **1** and **2**, assigning wires

► Insulate components, wires and connectors individually as shown and tie back.

Legend

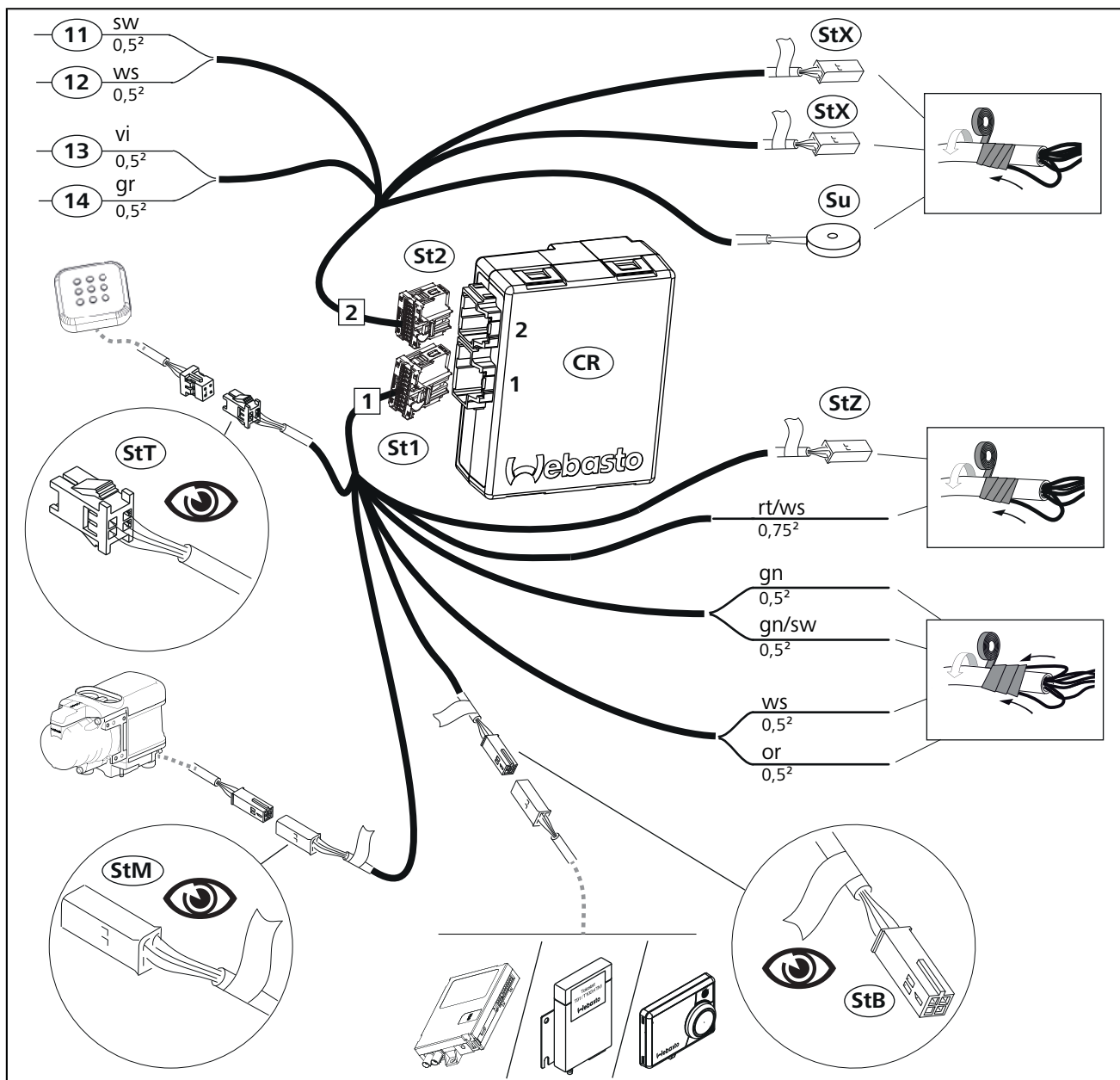

Fig. 97

Abbreviation	Component	Abbreviation	Component
CR	Cronus	StT	4-pin male plug for push button wiring harness
St1	16-pin black connector of Cronus wiring harness 1	SU	Buzzer, will not be used
St2	12-pin grey connector of Cronus wiring harness 2	StX	4-pin male plug, will not be used
StB	4-pin female plug for control element wiring harness	StZ	4-pin male plug for additional relay wiring harness, will not be used
StM	4-pin male plug for engine compartment wiring harness		



Preparing Cronus bracket

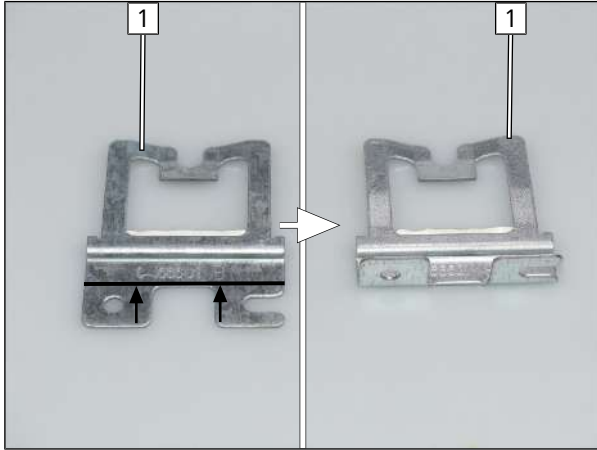

Fig. 98

► Bend bracket **1** as shown.

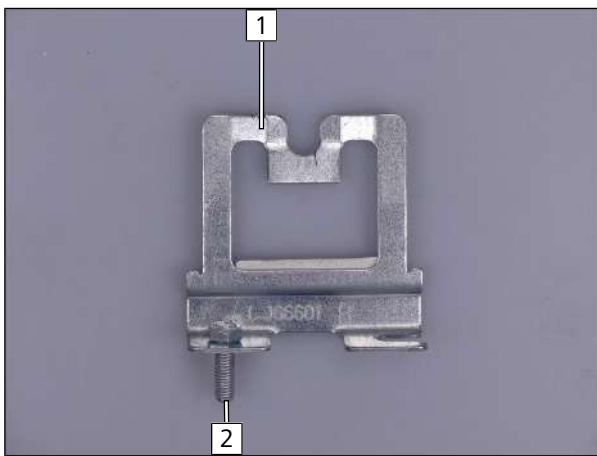

Fig. 99

- 1** Bracket
- 2** M5x16 bolt

Premounting Cronus

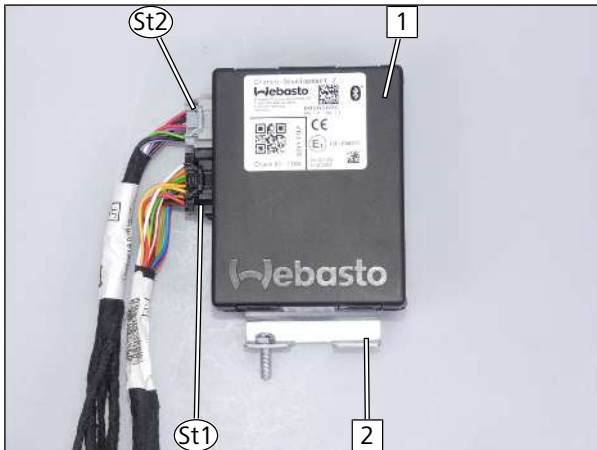

Fig. 100

- 1** Cronus
- 2** Bracket



Routing fan controller wiring harness

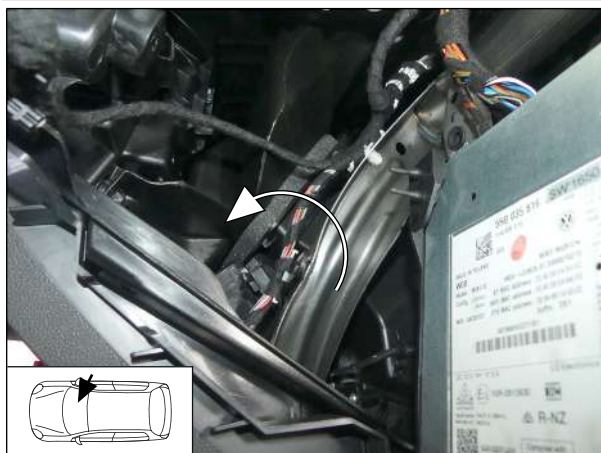

Fig. 101

- Route black (sw) wire **11** and white (ws) wire **12** as well as violet (vi) wire **13** and grey (gr) wire **14** of Cronus wiring harness in the direction of the centre console.



12.3 Wiring diagram

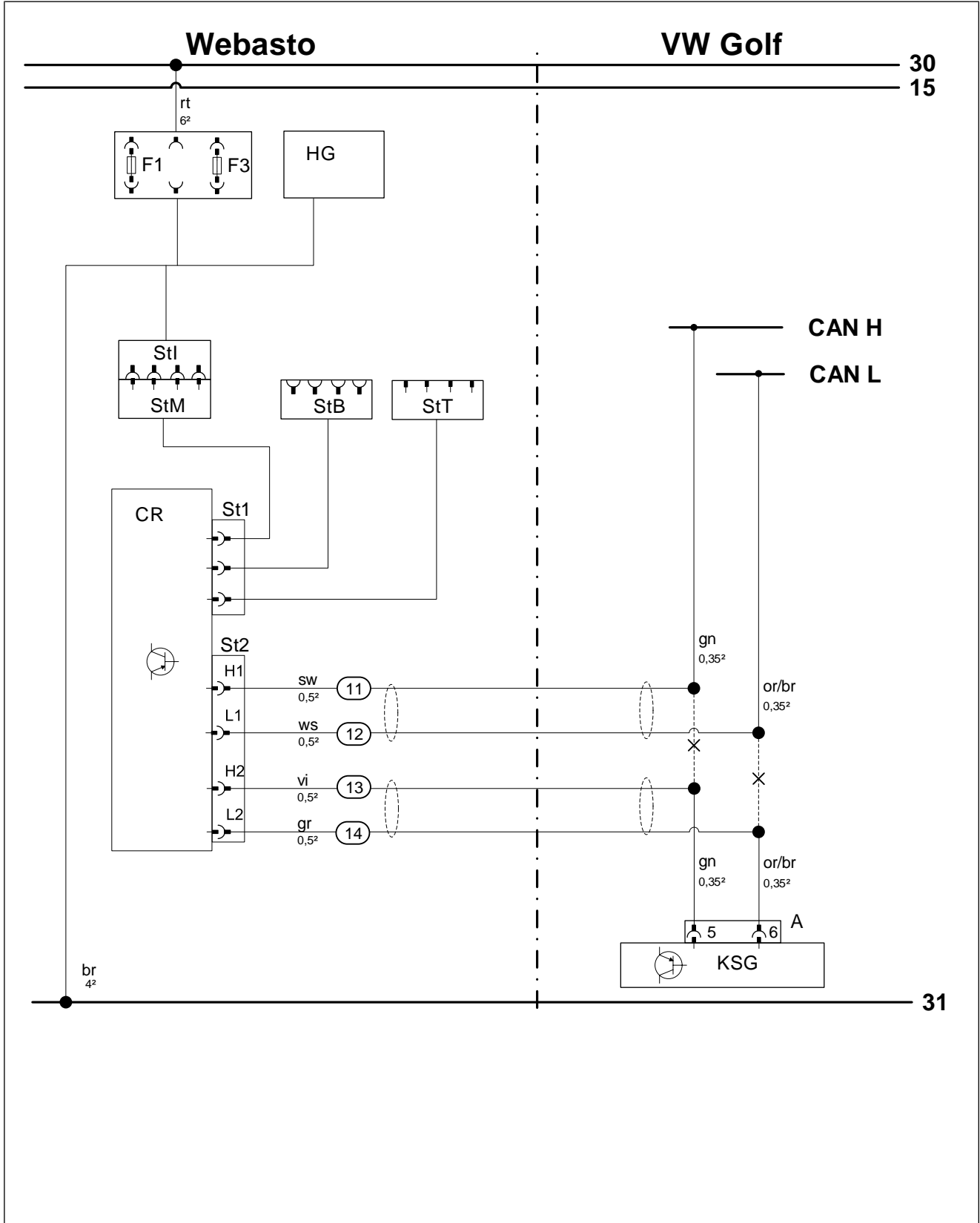

Fig. 102



Legend to wiring diagram



The vehicle connector and component designations are freely chosen by Webasto.
Cable colours may vary.

Vehicle components		Symbols	
Abbreviation	Component	Abbreviation	Explanation
KSG	Air-conditioning control unit	X	Cutting point
A	20-pin connector of A/C control unit		

Webasto components		Cable colours	
Abbreviation	Component	Abbreviation	Colour
CLR	Cold start module	bg	beige
CR	Cronus (passenger compartment control unit)	bl	blue
D1	Diode	br	brown
D2	Diode group	dbl	dark blue
Dia	Diagnosis connection	dgn	dark green
E	Male plug for Plug&Play wiring harness	ge	yellow
F	Female plug for Plug&Play wiring harness	gn	green
F0	Additional fuse for power supply	gr	grey
F1	Heater main fuse	hbl	light blue
F2	Fan main fuse	hgn	light green
F3	Cronus main fuse	la	salmon
HG	Heater TT-Evo	or	orange
LA	Power adapter	pk	pink
PWM GW	Pulse width modulator gateway	ro	Pink
RTD	Temperature sensor	rt	red
St1	16-pin, black connector of Cronus wiring harness 1	sw	black
St2	14-pin, grey connector of Cronus wiring harness 2	vi	violet
StB	4-pin female plug for control element wiring harness	ws	white
StI	Female plug for passenger compartment wiring harness		
StM	Male plug for engine compartment wiring harness		
StT	Male plug for push button wiring harness		
StZ	Male plug for additional relay		



12.4 Fan controller

Cutting point

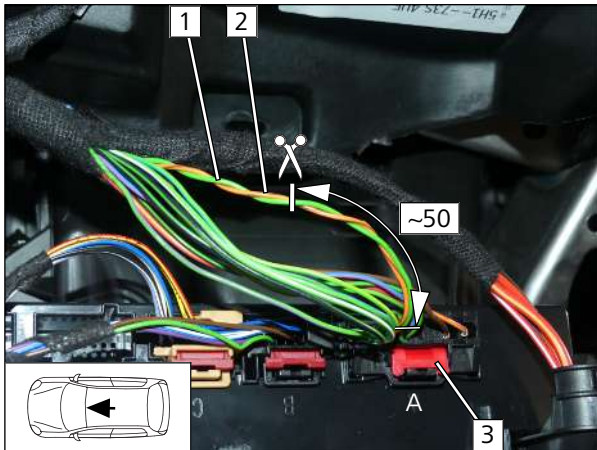

Fig. 103

- 1 Green (gn) wire of KSG connector A / pin 5
- 2 Orange/brown (or/br) wire of KSG connector A / pin 6
- 3 20-pin KSG connector A

Connection to air-conditioning control unit

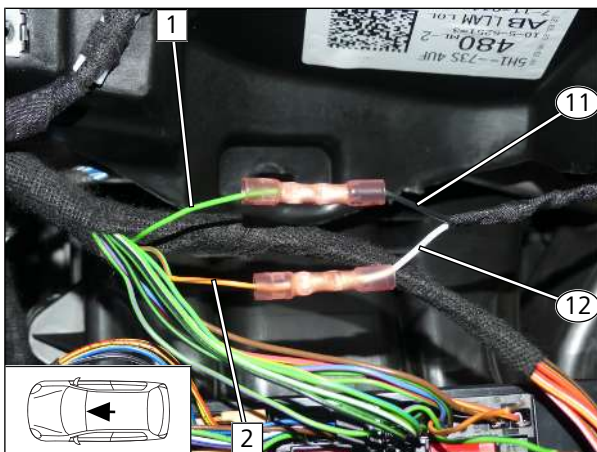

Fig. 104



Produce all the following electrical connections only with shrinkable butt connectors.

- ▶ 1. crimp
- ▶ 2. shrink

- 1 Green (gn) wire of CAN High
- 2 Orange/brown (or/br) wire of CAN Low
- 11 Black (sw) wire of Cronus wiring harness 2
- 12 White (ws) wire of Cronus wiring harness 2

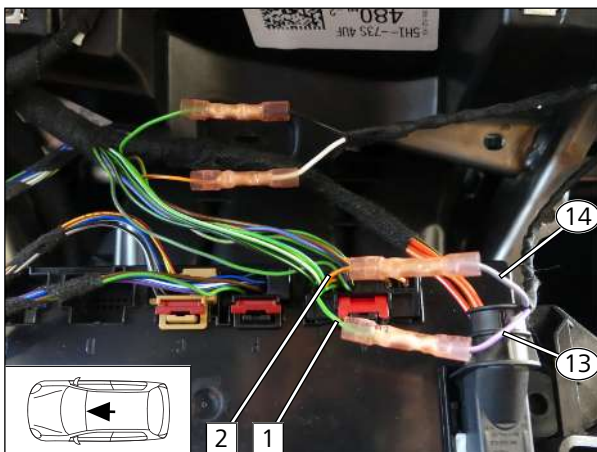

Fig. 105

- 1 Green (gn) wire of KSG connector A / pin 5
- 2 Orange/brown (or/br) wire of KSG connector A / pin 6
- 13 Violet (vi) wire of Cronus wiring harness 2
- 14 Grey (gr) wire of Cronus wiring harness 2

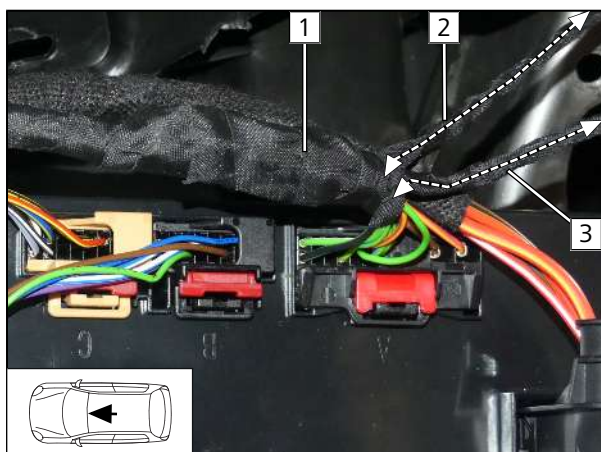

Fig. 106

► Attach Cronus wiring harnesses **2** and **3** as well as the shrunk butt connector to original vehicle wiring harness **1**.



Reinstall KSG.

Mounting Cronus



Fig. 107

1 M5x16 bolt, bracket, hole in KSG bracket, original vehicle hole, washer, nut



12.5 Connection of Cronus to push button



The installation location of the Cronus push button should be confirmed with the end customer and should comply with the installation conditions.

- ▶ Mount the push button and connect the marked male plug of Cronus wiring harness 1 with the connection plug of the Cronus push button as shown.

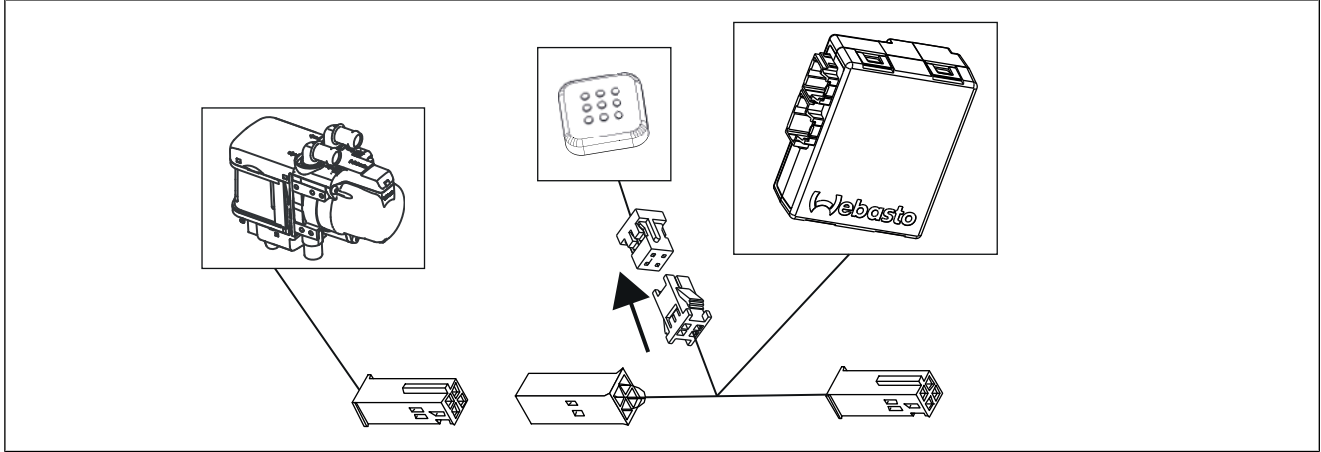

Fig. 108

12.6 Heater connection and installation of Telestart or MultiControl AM control element



Install the control element in accordance with the provided relevant general installation documentation. The installation location of the optional control element MultiControl or the push button of the Telestart option should be confirmed with the end customer and should comply with the installation conditions.

- ▶ Connect the marked male and female plugs of Cronus wiring harness 1 with the connection plug of the engine compartment wiring harness and the relevant control element as shown.

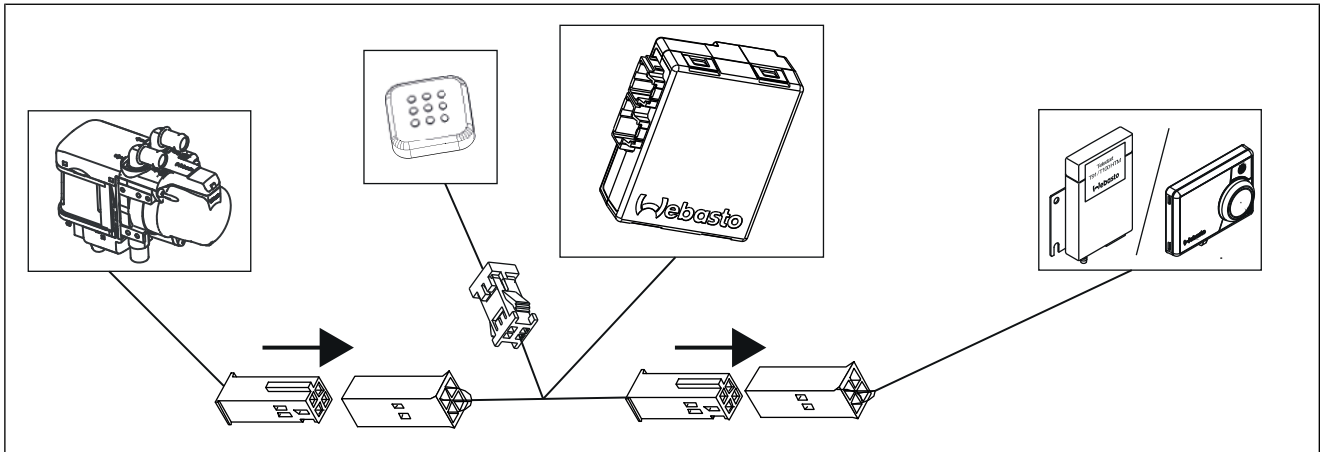

Fig. 109



12.7 Heater connection and installation of ThermoConnect control element



Install the control element in accordance with the provided relevant general installation documentation. The installation location of the push button of the ThermoConnect option should be confirmed with the end customer and should comply with the installation conditions.

Preparing Y wiring harness



The Y wiring harness mentioned in section 'Components used' must also be ordered.

- ▶ Locate connection plug **2** of ThermoConnect wiring harness on the wiring harness branch of Y wiring harness **1**.
- ▶ Disconnect black (sw) wire **3** from connection plug **2**, tie back and insulate.

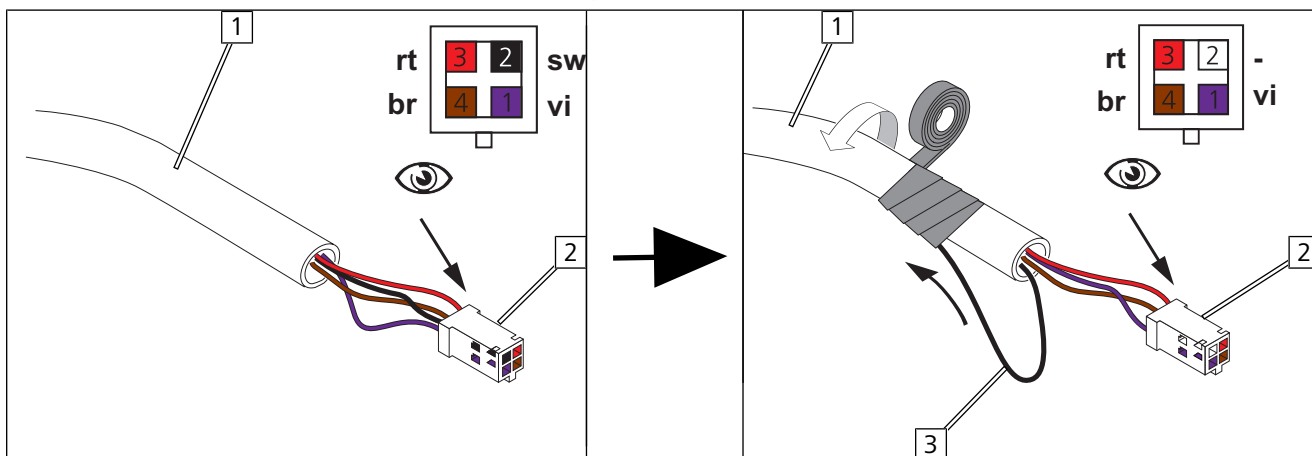

Fig. 110

Connecting wiring harnesses

- ▶ Connect the marked female plug **1** of Cronus wiring harness 1 and connection plug **2** of engine compartment wiring harness with Y wiring harness **3** and connect connection plug **4** of the ThermoConnect wiring harness with prepared connector **5** of Y wiring harness as shown.

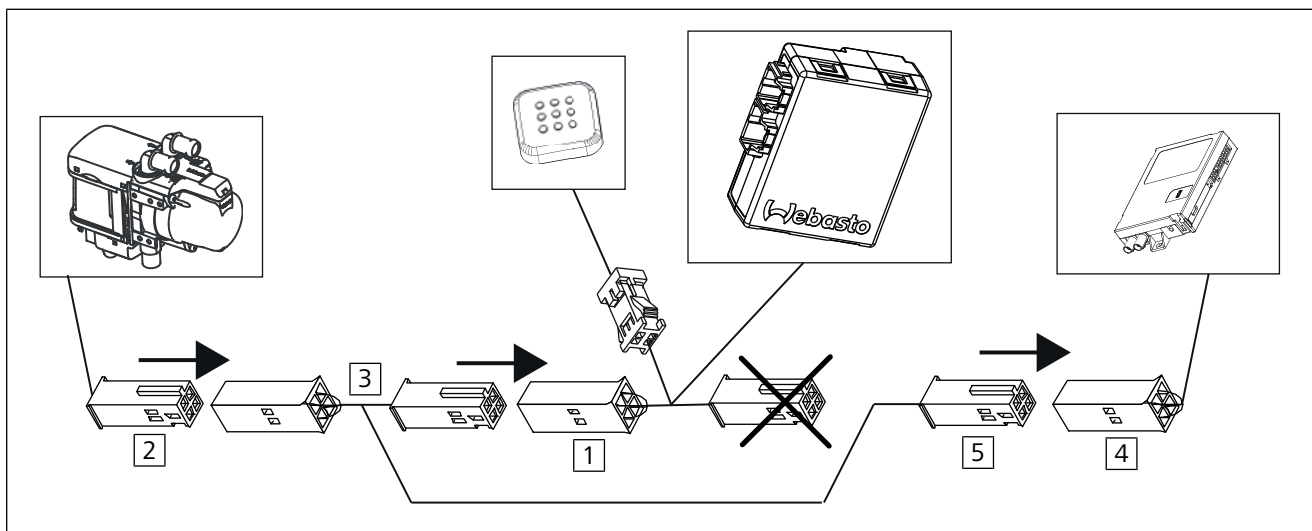

Fig. 111

These are the original instructions. The German language is binding.
You can request your language if it is missing. The telephone number of each country can be found in the Webasto service centre leaflet or the website of the respective Webasto representative of your country.

© Copyright 2021 - The contents of this document, including but not limited to text, photographs and graphics, are protected by copyright. All rights, including reproduction, publication, editing and translation in any way, shape or form, are reserved by Webasto.

Webasto Thermo & Comfort SE
Postfach 1410
82199 Gilching
Germany

Company address:
Friedrichshafener Str. 9
82205 Gilching
Germany

Technical Extranet: <https://dealers.webasto.com>



WWW.WEBASTO.COM



13 FuelFix drilling template

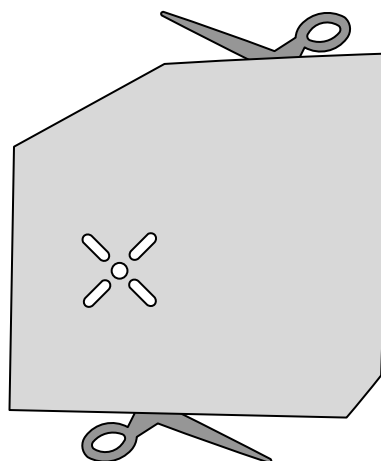

100mm



**Set print option to custom
scale on 100%.
Check scale 1:1 for print out-
put.**

0

100mm



14 FuelFix template

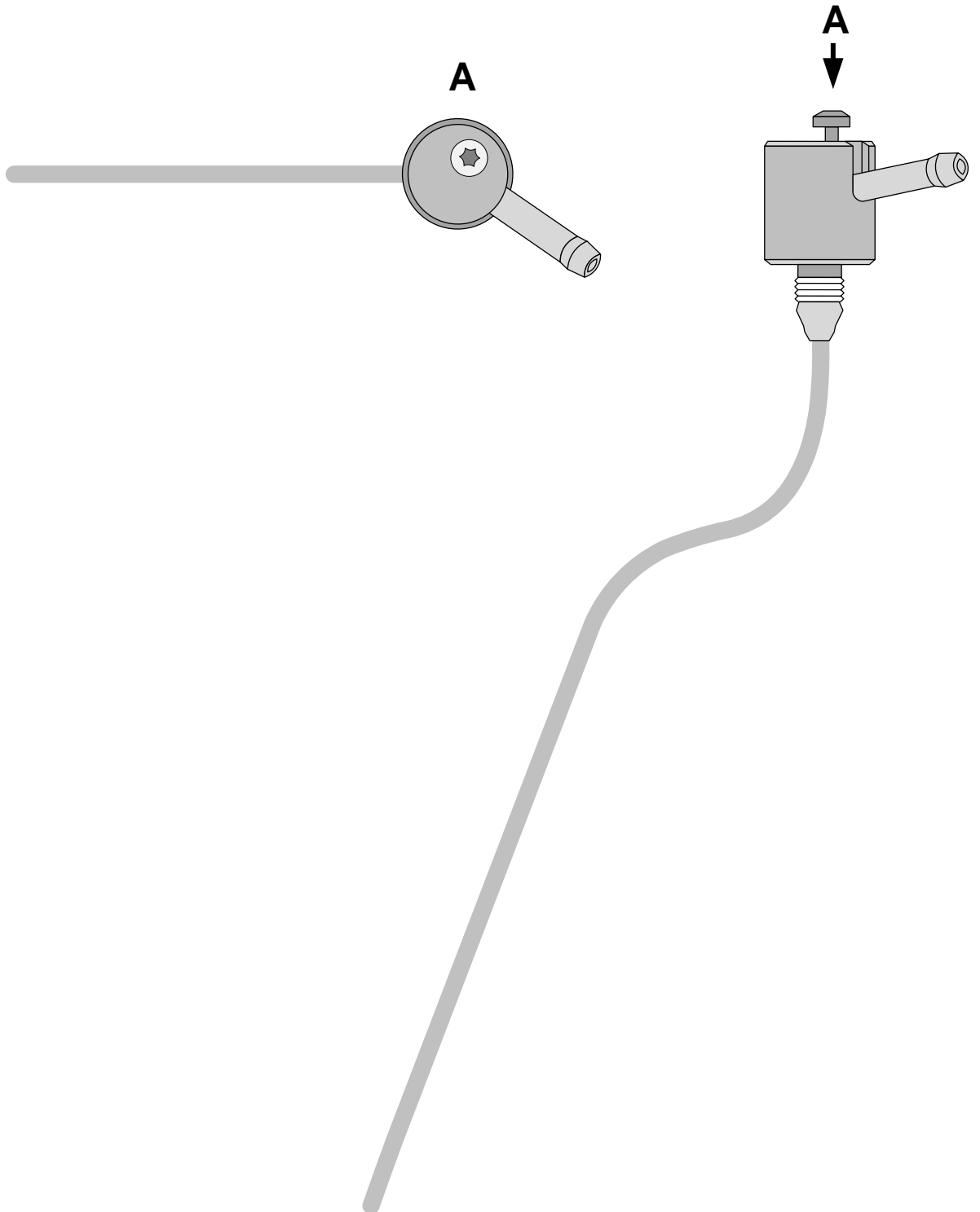

100mm



**Set print option to custom scale on 100%.
Check scale 1:1 for print output.**

0

100mm

15 Operating instructions



Vehicles with passenger compartment monitoring:

Further information can be found in the vehicle operating instructions.

- ▶ Deactivate passenger compartment monitoring for the heating operation



Information regarding the heating time:

We recommend matching the heating time to the driving time (heating time = driving time)

Example: for a driving time of approx. 20 min. (in one direction), we recommend not exceeding a switch-on time of 20 min.



Notes about the A/C control panel presettings

Your vehicle is equipped with a comfort air-conditioning control. As a result, **no** settings are required on the A/C control panel when switching off the vehicle. All necessary presettings, such as fan speed, temperature and flap positions are set automatically.



Note for parking heater function

Your vehicle is equipped with a passenger compartment and engine preheating unit.



Notes on parking heater exhaust outlet ¹

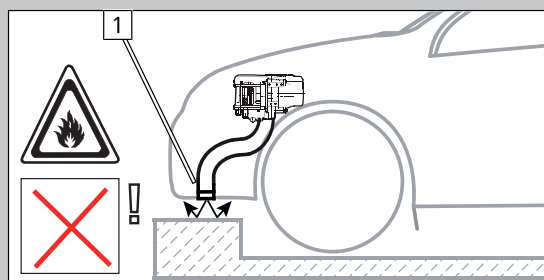
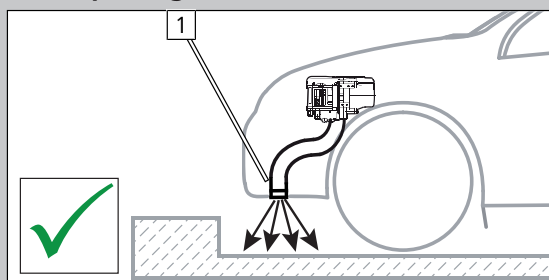

15.1 Installation location of fuses

Fuses in engine compartment



- 1** F3 - 5A Cronus main fuse
- 2** F2 - not in use
- 3** F1 - 20A heater main fuse

Fig. 112

