

K Installation documentation

for water heater Thermo Top Evo

'Island' coolant circuit without engine preheating

Jeep Compass

Left-hand drive vehicle

Manufacturer	Model	Type	Model year	EG-BE-No. / ABE		
Jeep	Compass	MP	from 2021	e3* 2007/46* 0508*...		
Motorisation	Fuel	Emission standard	Transmission type	Output [kW]	Displacement [cm ³]	Engine code
1.3 T-GDI Hybrid	Petrol	Euro6;WLTP;AP;...	6-speed AG	132	1332	46337540

Validity	Equipment variants	Model
		Compass
Verified equipment variants	2 zone automatic air-conditioning	x
	Xenon main headlights	x
	LED daytime running lights	x
	Halogen front fog lights	x
	Start button	x
	eAWD	x

Total installation time	Note
9.3 hours	

Contents

1	List of abbreviations	3	15	Tank extracting device template	53
2	Installation notes	4			
2.1	Information on Validity	4			
2.2	Components used	4			
2.3	Additional components from manufacturer	4			
2.4	Information on Total Installation Time	4			
2.5	Notes on installation, in coordination with the end customer	4			
3	About this document	5			
3.1	Purpose of the document	5			
3.2	Warranty and liability	5			
3.3	Safety	5			
3.4	Using this document	6			
4	Technical Information	7			
5	Preparations	8			
5.1	Vehicle preparation	8			
5.2	Heater preparation	8			
6	Installation overview	9			
7	Electrical system of engine compartment	10			
8	Mechanical system	13			
8.1	Preparing installation location	13			
8.2	Premounting heater	15			
8.3	Premounting heater	17			
8.4	Preparing battery carrier	18			
8.5	Mounting heater	22			
9	Coolant	24			
9.1	Hose routing diagram	24			
9.2	Coolant circuit installation	25			
10	Fuel	34			
10.1	Connecting and routing fuel line	34			
10.2	Mounting fuel pump	36			
10.3	Mounting tank extracting device	38			
10.4	Fuel pump connection	41			
11	Combustion air	42			
12	Exhaust	44			
13	Electrical system of passenger compartment	49			
13.1	Air-conditioning control	49			
14	Final work	50			

1 List of abbreviations

ASH	Spacer bracket
DP	Fuel pump
eAWD	All-wheel drive
EFIX	Exhaust end fastener
HG	Heater
SH2	Engine compartment fuse holder for F1/F2
TE	Tank extracting device
UP	Coolant pump
Veh.	Vehicle
X10	Female plug for control element

2 Installation notes

2.1 Information on Validity

This installation documentation applies to vehicles listed on page 1, assuming technical modifications to the vehicle do not affect installation, any liability claims excluded. Depending on the vehicle version and equipment, modifications may be necessary during installation with respect to this installation documentation. Vehicle and engine types, equipment variants and other specifications not listed in this installation documentation have not been tested.

2.2 Components used

Designation	Order number
Basic delivery scope of Thermo Top Evo	In accordance with price list
Installation kit for Jeep Compass 2021 petrol	1328277A
Additional 'Webasto Comfort' A/C control kit for Jeep	1325260_
In case of Telestart, control element, as well as indicator lamp in consultation with end customer	In accordance with price list

2.3 Additional components from manufacturer

Designation	Jeep order number
Gasket for 1.3TGDI Hybrid tank fitting	53114701

2.4 Information on Total Installation Time

The total installation time includes the time needed for mounting and demounting the vehicle-specific components, the heater specific installation time and all other times required for the system integration and initial start-up of the heater.

The total installation time may vary for vehicle equipment other than provided.

2.5 Notes on installation, in coordination with the end customer

- ▶ Arrange for the vehicle to be delivered with the tank only about ¼ full.
- ▶ The installation location of the following elements should be chosen in coordination with the end customer:
 - the push button in case of the Telestart and/or ThermoCall and/or ThermoConnect options
 - the MultiControl CAR option

We recommend:

- installing a Thermo Top Evo 4. The heater is integrated into the coolant circuit as an 'island' and heats up the vehicle passenger compartment. There is no engine pre-heating.

3 About this document

3.1 Purpose of the document

This installation documentation is part of the product and contains all the information required to ensure professional vehicle specific installation of the:

Thermo Top Evo heater

3.2 Warranty and liability

Webasto shall assume no liability for defects, damage and injuries resulting from a failure to observe the installation, repair and operating instructions of the information contained in them.

This liability exclusion particularly applies to improper installations and repairs by untrained persons or in the case of a failure to use genuine spare parts.

The liability due to culpable disregard to life, limb or health and due to damage or injuries caused by a wilful or reckless breach of duty remain unaffected, as does the obligatory product liability.

Installation should be carried out according to the general, standard rules of technology. Unless specified otherwise, fasten hoses, lines and wiring harnesses to original vehicle lines and wiring harnesses using cable ties. Insulate loose wire ends and tie back. Connectors on electronic components must audibly snap into place during assembly.

Spray unfinished body areas, e.g. drilled holes, with anti-corrosion wax (Tectyl 100K).

Observe the instructions and guidelines of the respective vehicle manufacturer for demounting and mounting vehicle specific components.

The initial start-up is to be executed with the Webasto Thermo Test Diagnosis.

When installing a programmable control module (e.g. a PWM Gateway), the corresponding settings must be checked or adjusted.

3.2.1 Statutory regulations governing installation

The Thermo Top Evo heater has been type-tested and approved in accordance with ECE-R 10 (EMC) and ECE-R 122 (heater). The regulations of these guidelines are binding in the scope of the Directive 70/156/EEC and/or 2007/46/EC (for new vehicle models from 29/04/2009) and should also be observed in countries in which there are no special regulations.

The heater is licensed in accordance with paragraph 19, section 3, No. 2b of the StVZO (German Road Traffic Licensing Authority).

3.3 Safety

Qualifications of installation personnel

The installation personnel must have the following qualifications:

- Successful completion of Webasto training
- Corresponding qualification for working on technical systems

Regulations and legal requirements

The regulations from the heater's general installation and operating instructions must be observed.

3.3.1 Safety information on installation

Danger posed by live parts

- ▶ Prior to installation, disconnect the vehicle from the voltage supply.
- ▶ Make sure the electrical system is earthed correctly.
- ▶ Always comply with legal requirements.
- ▶ Observe data on type label.

Danger of fire and leaking toxic gases due to improper installation

- ▶ Vehicle parts in the vicinity of the heater must be protected against excessive heating by the following measures:
 - ⇒ Maintain minimum safety distances.
 - ⇒ Ensure adequate ventilation.
 - ⇒ Use fire-resistant materials or heat shields.

Danger due to sharp edges

- Lacerations
 - Short circuit due to electrical wire damage
- ▶ Fit protectors on sharp edges.

3.4 Using this document

Before installing and operating the heater, read this installation documentation, the installation instructions of the heater, the operating instructions and supplementary sheets provided.

3.4.1 Explanatory Notes on the Document

There is an identification mark near the respective work step to allow you to quickly allocate the other applicable documents to the Webasto components to be installed:

Generally valid Webasto documentation	
Vehicle-specific installation documentation	
Vehicle-specific installation documentation of the cold start kit	
Webasto Comfort A/C control	
Webasto Standard A/C control	
Tank extracting device (e.g. FuelFix)	
Exhaust end fastener (EFIX)	
Combustion air intake silencer	
Spacer bracket (ASH)	

3.4.2 Use of symbols



DANGER

Type and source of the risk

Consequences: Failure to follow the instructions can result in death

► Actions to protect yourself against risks.



WARNING

Type and source of the risk

Consequences: Failure to follow the instructions can lead to serious or even fatal injuries

► Actions to protect yourself against risks.



CAUTION

Type and source of the risk

Consequences: Failure to follow the instructions can lead to minor injuries

► Actions to protect yourself against risks.



Type and source of the risk

Consequences: Failure to follow the instructions can lead to material damage

► Actions to protect yourself against risks.



Reference to the vehicle manufacturer's specific documents.



Note on a special technical feature

3.4.3 Work step identification marks

The ongoing work step is indicated on the outside top corner of the page:

Mechanical system	Electrical system	High-voltage	Coolant
Combustion air	Fuel	Exhaust	Software

3.4.4 Orientation aid

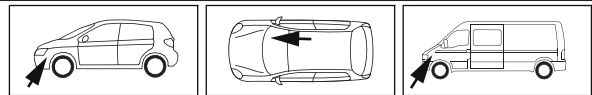

The arrow indicates the position on the vehicle and the viewing angle

3.4.5 Use of highlighting

Highlight	Explanation
✓	Action
►	Necessary action
⇒	Result of an action
1 / 12 / a1	Position numbers for the image descriptions
① / ⑫ / Ⓐ	Position numbers for the image descriptions for electrical wires and components as well as coolant hose sections

4 Technical Information

Dimension specifications

- All dimensions specified in mm
- Perforated brackets and mounting angles are shown to scale
- Observe data regarding scale on the templates

Tightening torque specifications

- Tightening torque values of 5x13 heater bolts and 5x11 heater stud bolts = 8Nm
- Tightening torque values of 5x15 retaining plate of water connection piece bolts = 7Nm
- 5x12 bolt tightening torque of 2-part heater bracket = 6Nm
- Tighten other bolt connections in accordance with manufacturer's instructions or in accordance with state-of-the-art-technology

Temperature specification for heat shrink plastic tubings

- Fabric heat shrink tubing: shrink temperature max. 230°C
- Standard heat shrink plastic tubing: shrink temperature max. 300°C

Necessary special tools

- Hose clamp pliers for auto-tightening hose clamps
- Hose clamp pliers for Clic hose clamps of type W
- Hose clamping pliers
- Hose cutter
- Automatic wire stripper 0.2 - 6 mm²
- Crimping pliers for cable lugs 0.5 – 10 mm²
- Crimping pliers for male connector 0.14 – 6 mm²
- Crimping pliers for connector 0.25 – 6 mm²
- Torque wrench for 2.0 - 10 Nm
- Deep-hole marker
- Metric thread-setter kit
- Webasto Thermo Test Diagnosis with current software

5 Preparations

5.1 Vehicle preparation



Further information can be found in the vehicle manufacturer's technical documentation.

Vehicle area	Components to be removed	Other applicable documents
General	<ul style="list-style-type: none"> ▶ Open the fuel tank cap ▶ Ventilate the fuel tank ▶ Close the fuel tank cap again ▶ Depressurise the cooling system 	
Engine compartment and body	<ul style="list-style-type: none"> ▶ Drain off the coolant ▶ Disconnect the battery and remove it with the carrier ▶ Engine design cover ▶ Complete air filter box ▶ Windscreen wiper ▶ Water drain chamber cover ▶ Front wheel on the driver's side ▶ Wheel-well inner panel on the driver's side ▶ Wheel-well inner panel on the front passenger's side ▶ Bumper trim 	
Passenger compartment	<ul style="list-style-type: none"> ▶ Instrument panel side trim on the driver's side ▶ Lower instrument panel trim on the driver's side ▶ A-pillar trim on the driver's side ▶ Centre tunnel side trim on the driver's and front passenger's side ▶ Lower air duct on the driver's side ▶ Accelerator pedal ▶ Rear bench seat ▶ Open the tank fitting service lid 	



DANGER

Risk of fire and explosion due to leaking fuel and escaping fuel vapours.



Carry out the following work only during the corresponding installation sequence:

Vehicle body	▶ Tank fitting	
--------------	----------------	--

5.2 Heater preparation

Engine compartment	<ul style="list-style-type: none"> ▶ Remove years that do not apply from the type and duplicate label ▶ Attach the duplicate label (type label) in the appropriate place in the engine compartment 	
--------------------	--	--

6 Installation overview

Installation overview

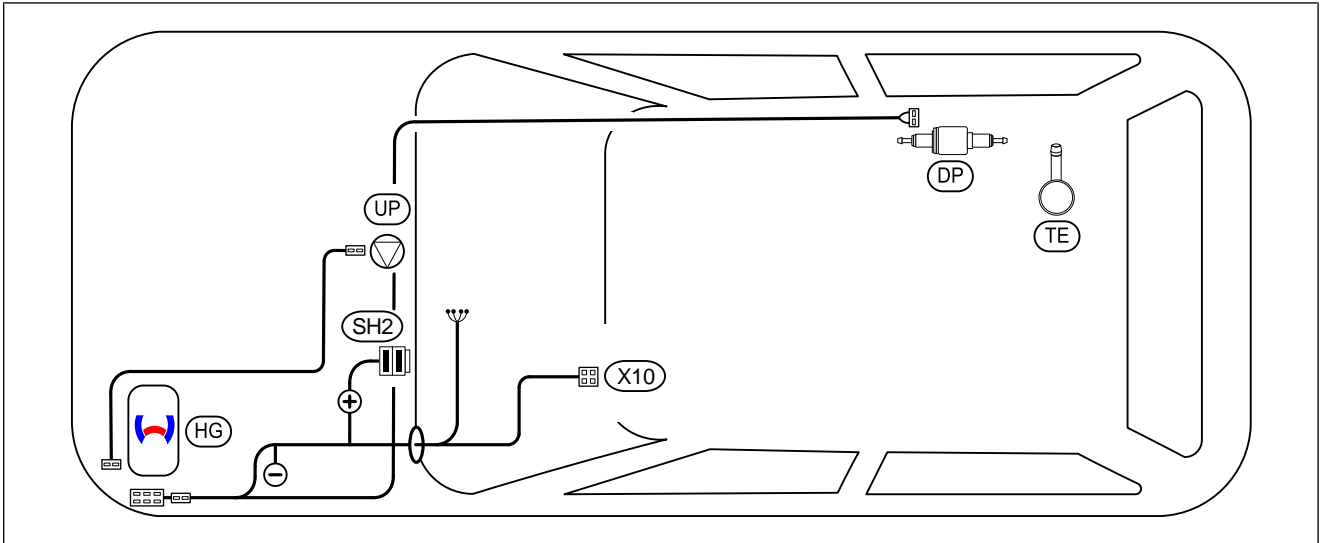
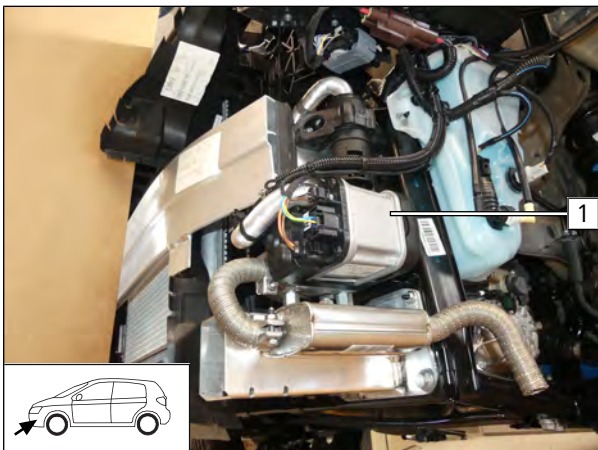

Fig. 1

Legend to installation overview

Abbreviation	Component
DP	Fuel pump
HG	Heater
SH2	Engine compartment fuse holder for F1/F2
UP	Coolant pump
TE	Tank extracting device
X10	Female plug for control element

Heater installation location



1 Heater

Fig. 2



7 Electrical system of engine compartment

Removing clip



1 Original vehicle clip

Fig. 3

Preparing perforated bracket

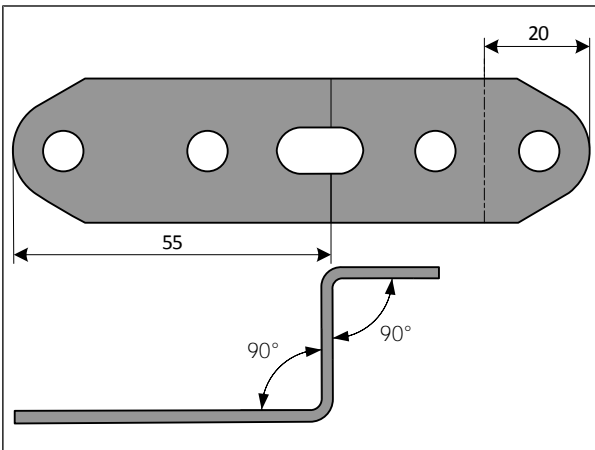
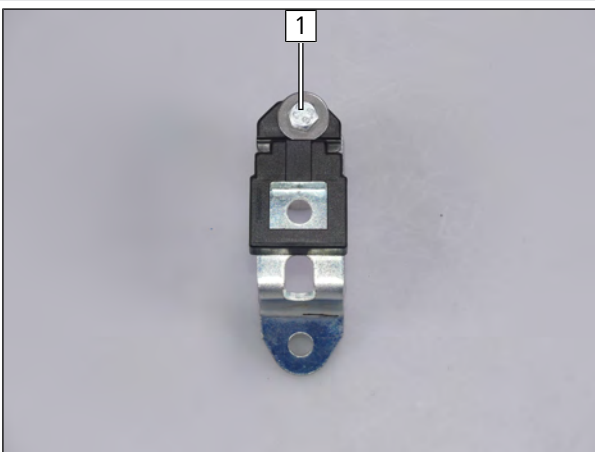

Fig. 4

Installing SH2



1 M5x16 bolt, large diameter washer, retaining plate, perforated bracket, large diameter washer, M5 nut

Fig. 5

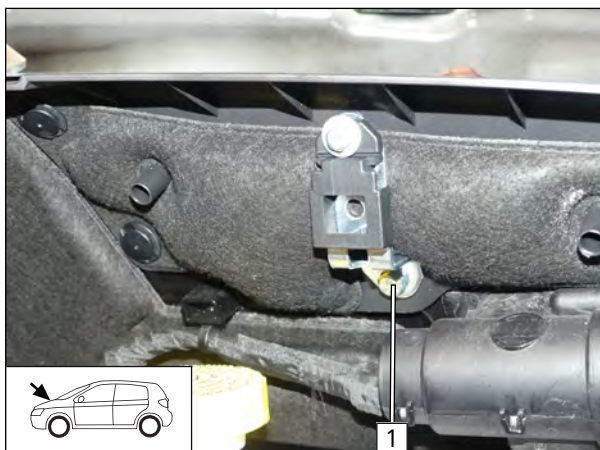

Fig. 6

- 1 M6x20 bolt, premounted perforated bracket, original vehicle hole, M6 flanged nut

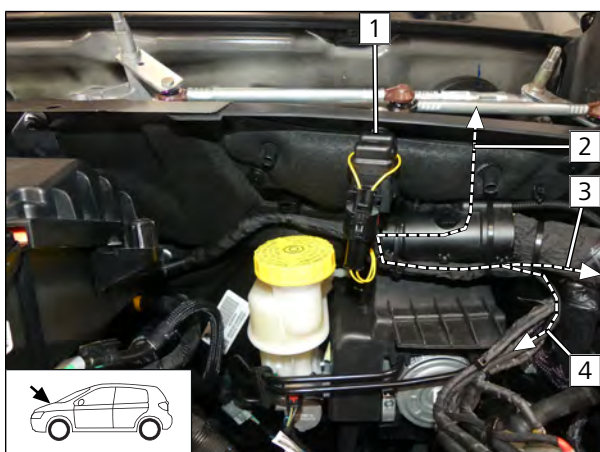

Fig. 7

- 1 SH2 with fuse F1 and F2
- 2 Passenger compartment wiring harnesses, control element and earth wire
- 3 Heater wiring harness
- 4 Positive wire

Passenger compartment wiring harness pass through

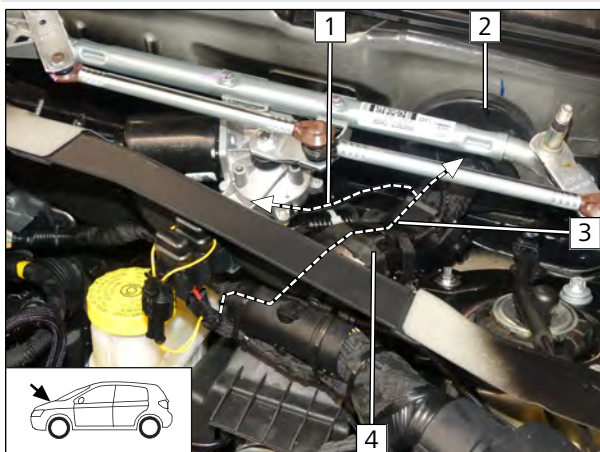

Fig. 8



To prevent water seeping into the passenger compartment, the wiring harness must be routed upwards to the protective rubber plug and this plug must then be sealed with a suitable sealing compound.

- 1 Earth wire
- 2 Protective rubber plug
- 3 Passenger compartment and control element wiring harnesses
- 4 Cable duct



Mounting earth wire

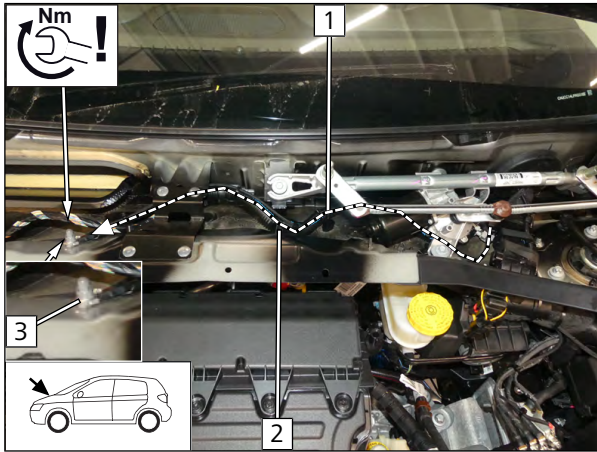

Fig. 9



DANGER

Observe tightening torque

- 1 Earth wire
- 2 Original vehicle wiring harness
- 3 Original vehicle earth support point

Mounting positive wire

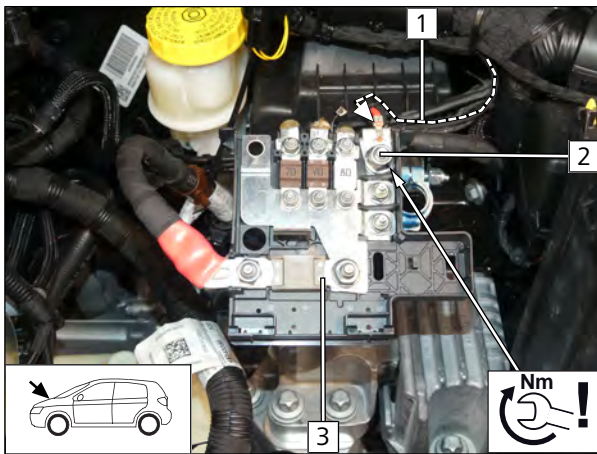

Fig. 10



DANGER

Observe tightening torque

- 1 Positive wire
- 2 Original vehicle positive support point
- 3 Positive battery distributor

HG wiring harness routing

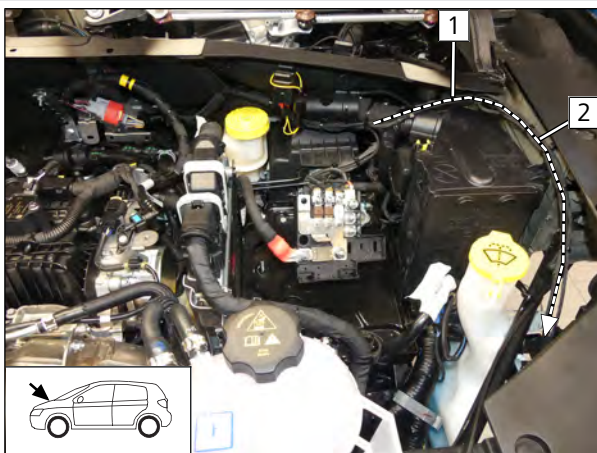

Fig. 11

- 1 Original vehicle wiring harness
- 2 HG wiring harness



8 Mechanical system

8.1 Preparing installation location

Fitting edge protection

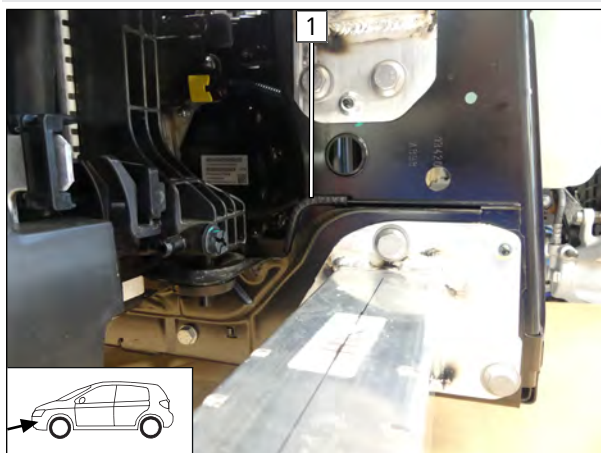

Fig. 12

- 1 70 long, narrow edge protection

Drilling holes for mounting heater

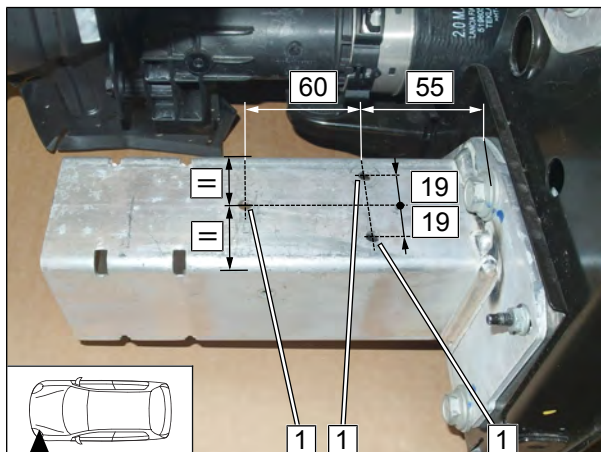

Fig. 13

- 1 Ø6.5 hole

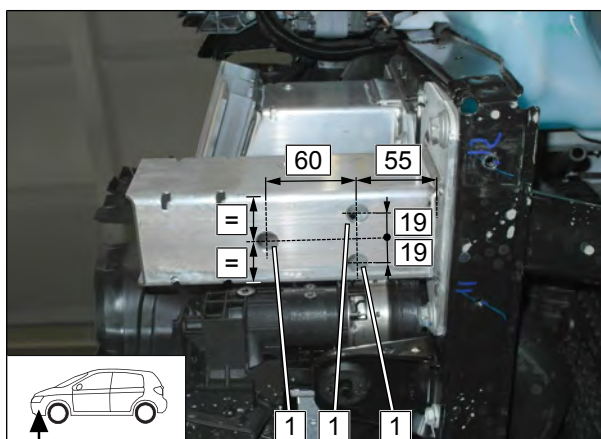
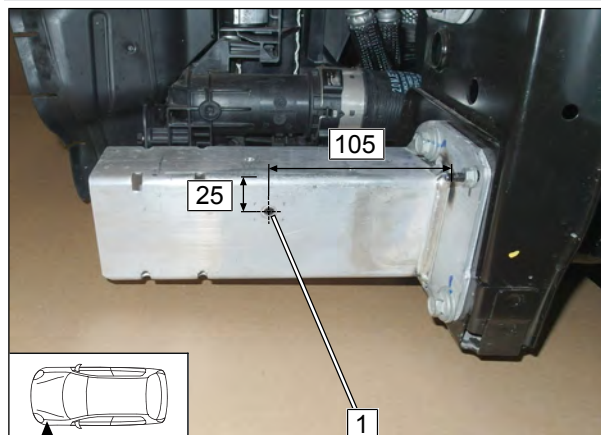

Fig. 14

- 1 Ø16 hole



Drilling hole for mounting exhaust silencer



1 7mm dia. hole

Fig. 15

Drilling hole for combustion air intake silencer installation

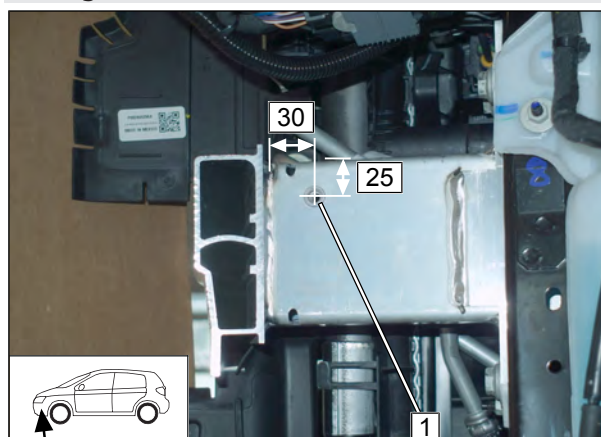

1 Insert rivet nut into 9mm dia. hole

Fig. 16



8.2 Premounting heater

Mounting, aligning and fastening with 7Nm water connection piece with sealing ring and retaining plate

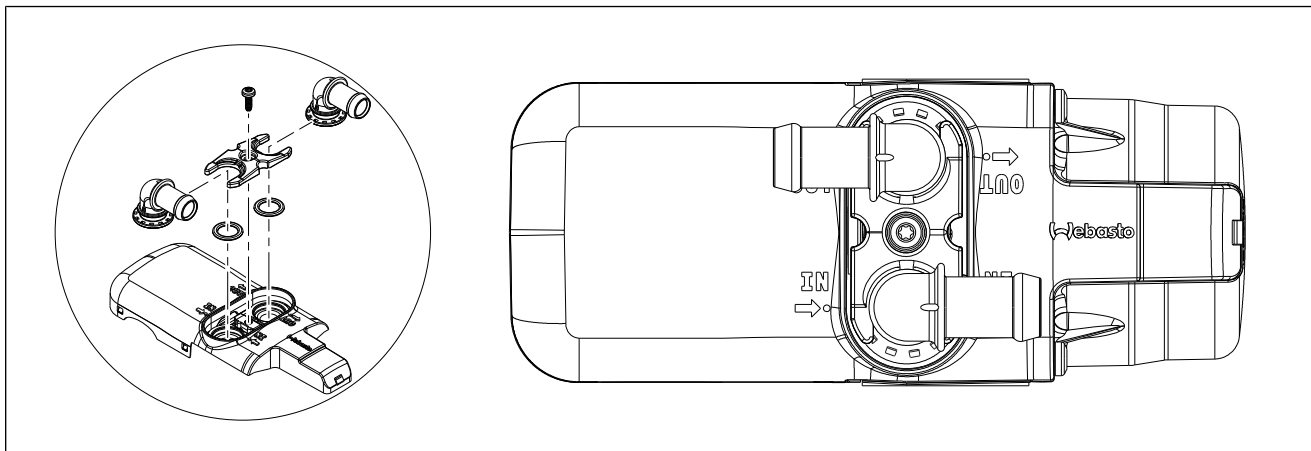

Fig. 17

Mounting M6/5x15 self-tapping stud bolt variant A

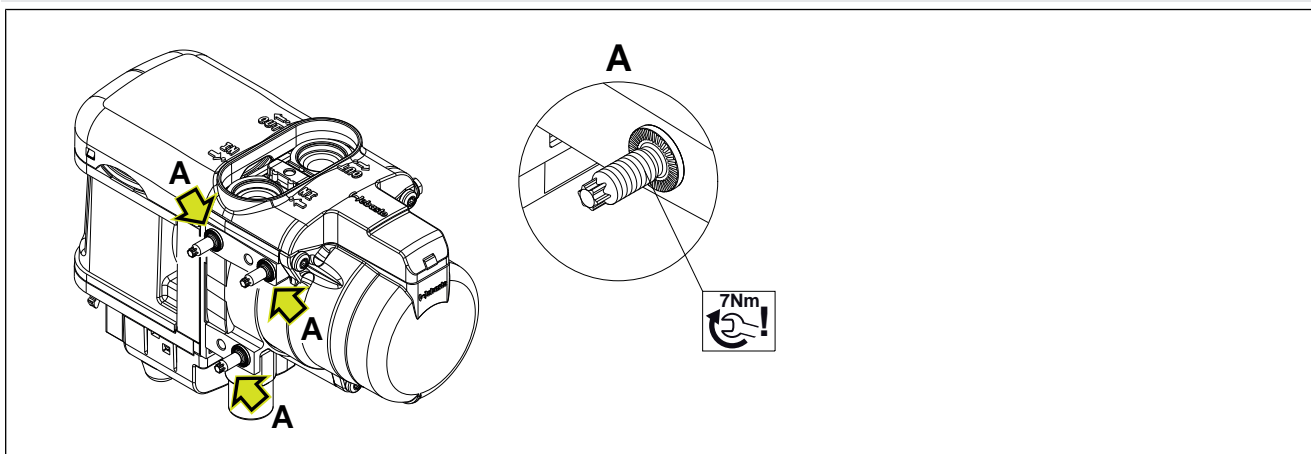

Fig. 18

Mounting spacer nuts

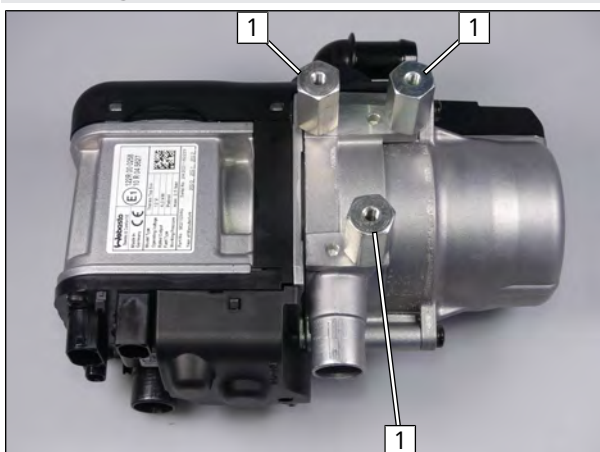

Fig. 19



Mounting fuel hose and clip-type cable tie

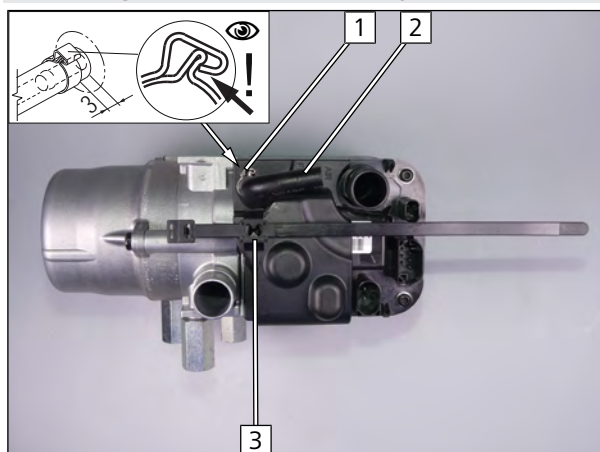

Fig. 20

- 1 Ø10 clamp
- 2 90° moulded hose
- 3 Clip-type cable tie, existing hole

Cutting combustion air pipe to length

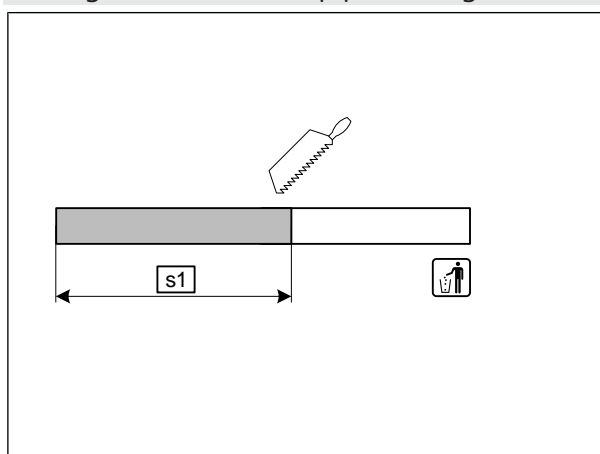

Fig. 21

- s1 630

Installing combustion air pipe

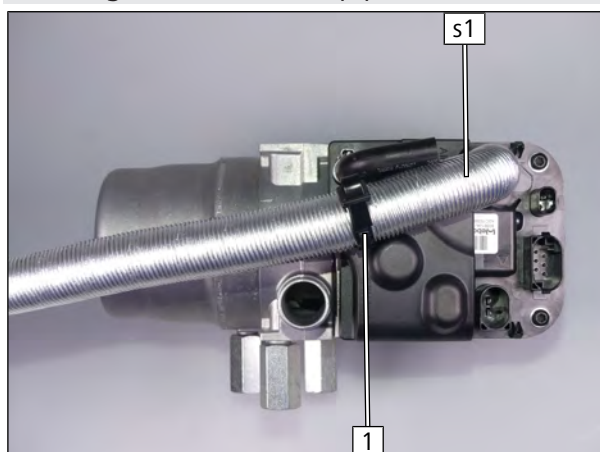

Fig. 22



Observe the installation instructions of the combustion air intake silencer.

- 1 Tighten clip-type cable tie

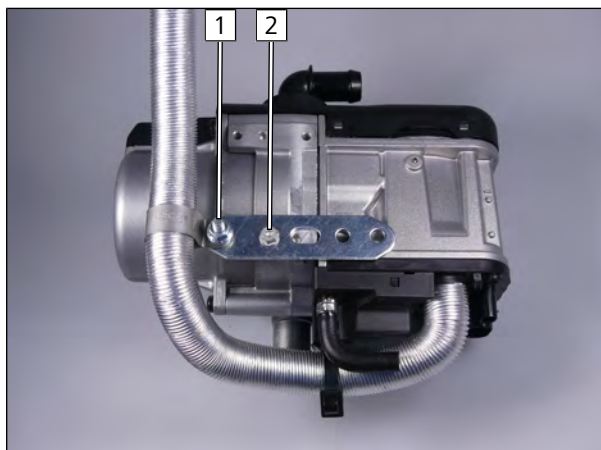

Fig. 23

- 1 M6x20 bolt, perforated bracket, Ø25 clamp, M6 flanged nut
- 2 5x13 self-tapping bolt

8.3 Premounting heater

Cutting hoses to length

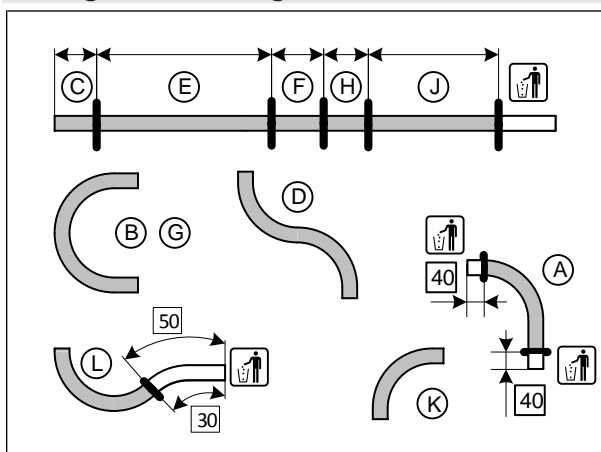

Fig. 24

(A)	90° moulded hose
(B)	180° moulded hose
(C)	60
(D)	2x90° moulded hose
(E)	830
(F)	100
(G)	180° moulded hose
(H)	160
(J)	880
(K)	90° moulded hose
(L)	135° moulded hose

Mounting fabric heat shrink tubings

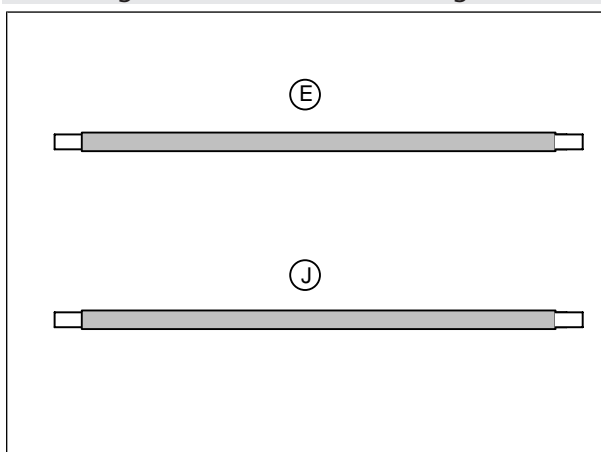

Fig. 25



- ▶ 1. Slide on and cut to length
- ▶ 2. Shrink, use at most 230 °C



Mounting hoses **F** , **G** and **H**

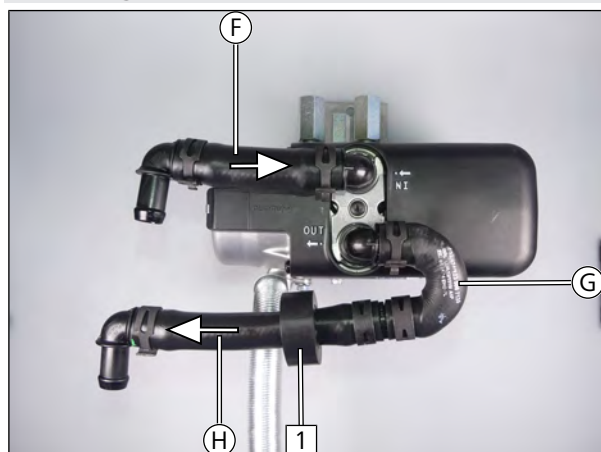

Fig. 26

1 Ø22 rubber isolator

8.4 Preparing battery carrier

Removing original vehicle control unit

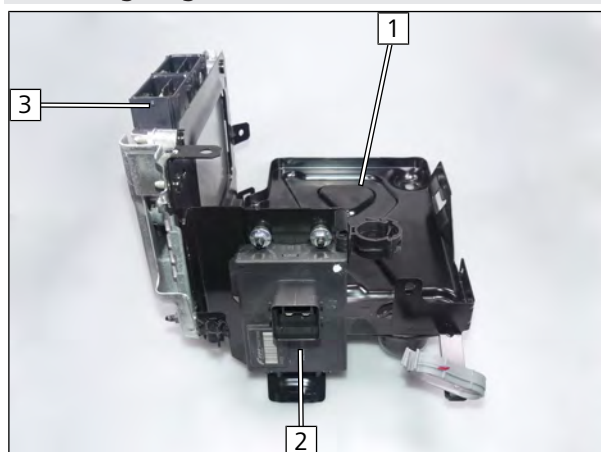

Fig. 27

- 1** Battery carrier
- 2** Control unit
- 3** Engine control unit

Adapting battery carrier

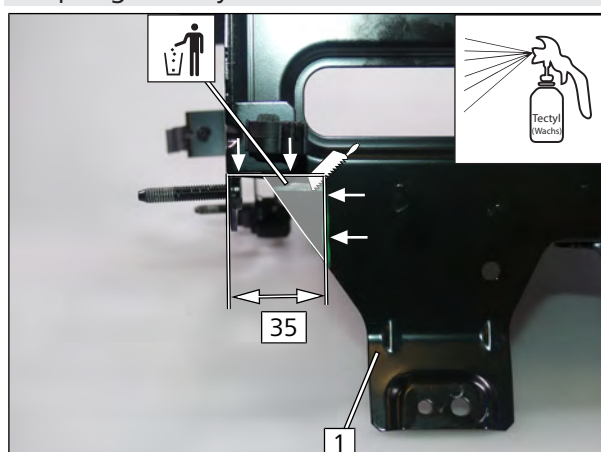

Fig. 28

► Cut out marked area of battery carrier **1** as shown.



Mounting edge protection on battery carrier

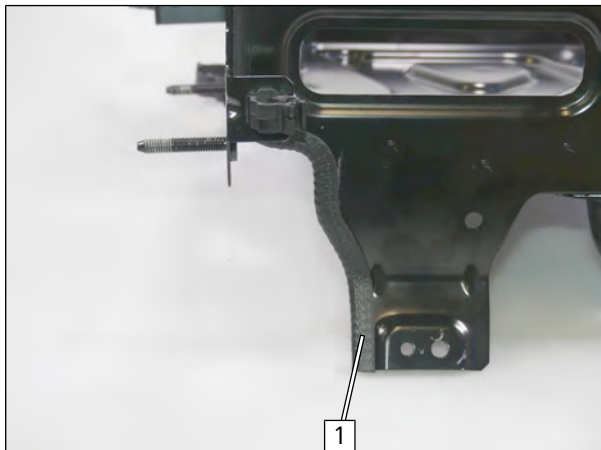

Fig. 29

1 Edge protection



Fig. 30

1 Clip (will be reused)



Fig. 31

1 Tab

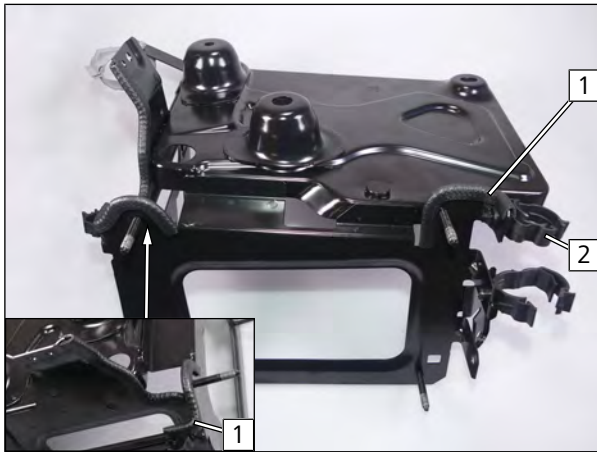

- 1 Narrow edge protection
- 2 Original vehicle clip

Fig. 32

Copying hole pattern and drilling hole



► Drill holes at positions **X** and **Y** as shown in next figures.

Fig. 33

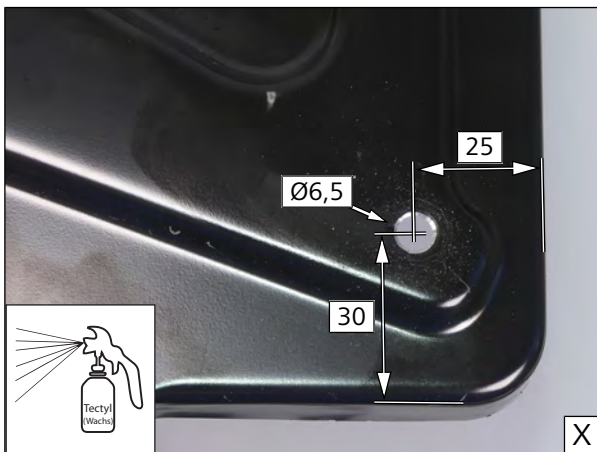

Fig. 34

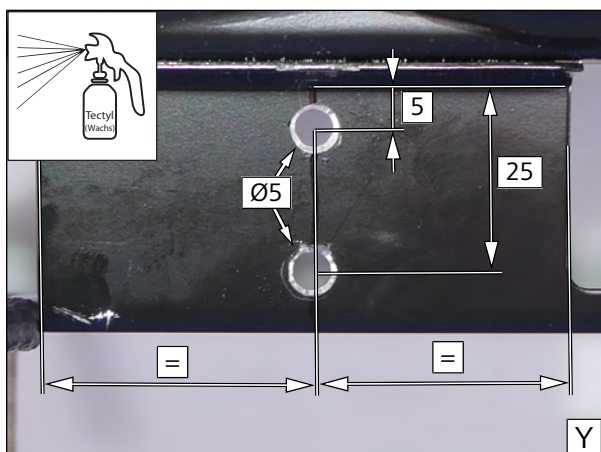

Fig. 35

Mounting angle bracket

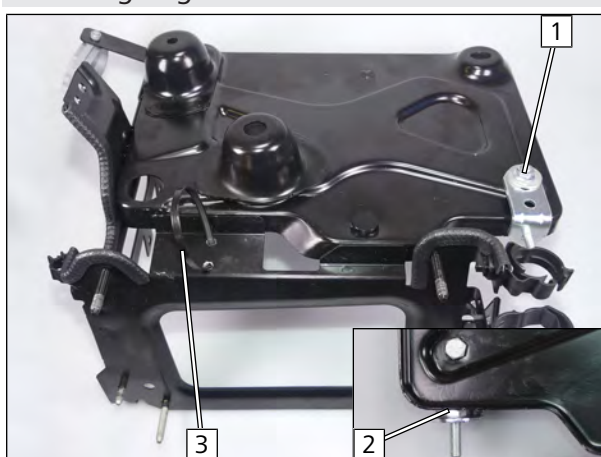

Fig. 36

- 1 M6x12 bolt, hole in carrier, oblong hole in angle bracket, large diameter washer, M6 flanged nut
- 2 M6x20 bolt
- 3 Cable tie

Fitting edge protection on control unit cover

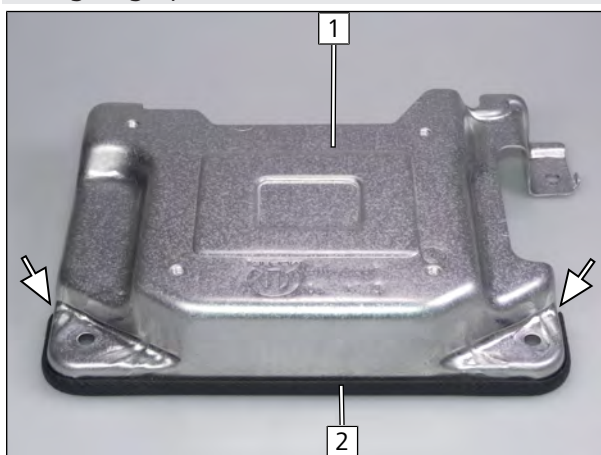

Fig. 37

- 1 Control unit cover
- 2 Narrow edge protection



Mounting control unit

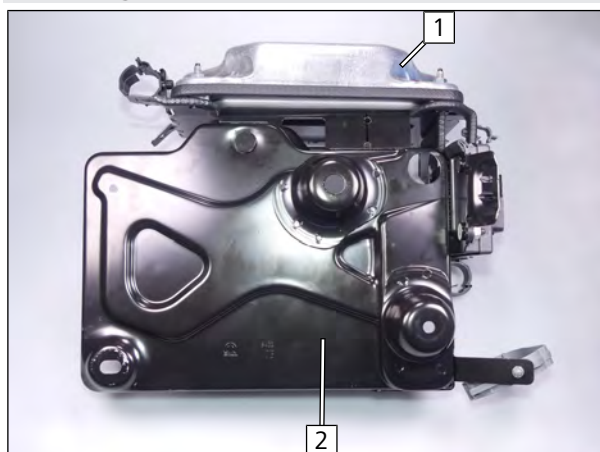

Fig. 38

- 1 Control unit with cover
- 2 Battery carrier

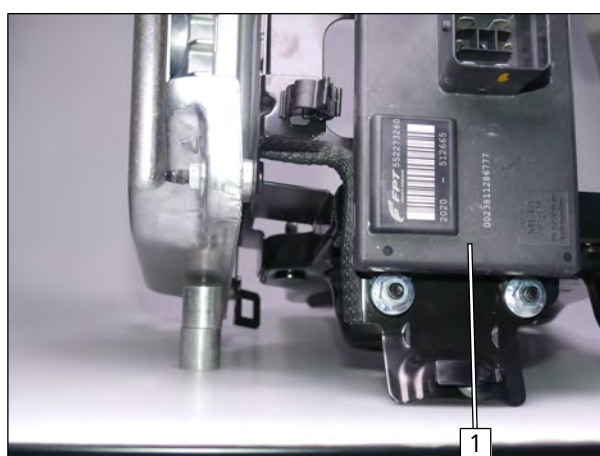

Fig. 39

- 1 Control unit

8.5 Mounting heater

Mounting heater

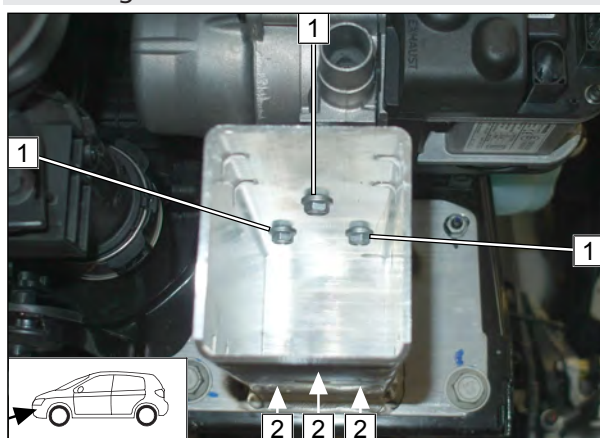
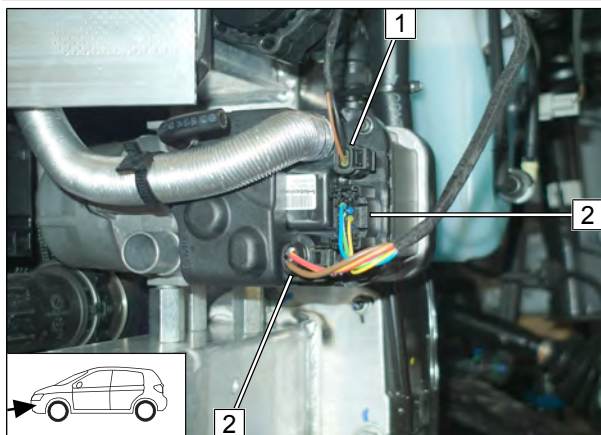

Fig. 40

- Pass M6x16 bolt with serrated flange 1 through 16mm dia. hole 2.



Mounting wiring harnesses



- 1 Coolant pump wiring harness connector
- 2 Heater wiring harness connector

Fig. 41



9 Coolant

9.1 Hose routing diagram

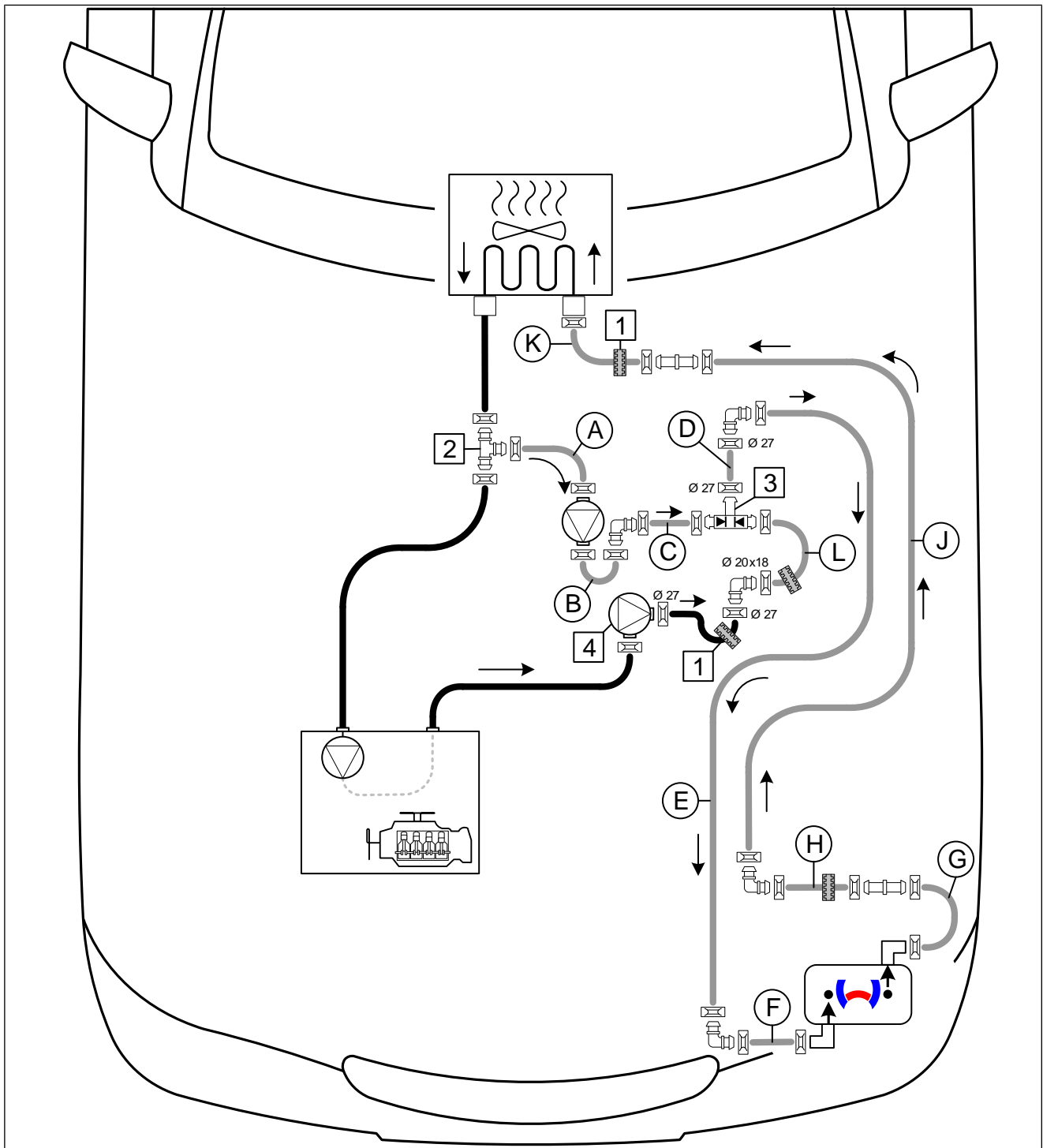

Fig. 42

All spring clips without a specific designation  = Ø25

All rubber isolators without a specific designation  = Ø22

All connecting pipes without a specific designation  or  = Ø18x18

1 Ø25 rubber isolator; **2** Ø18 T-piece; **3** Ø18 double non-return valve;

4 Original vehicle coolant pump



9.2 Coolant circuit installation

Dismantling original vehicle connector

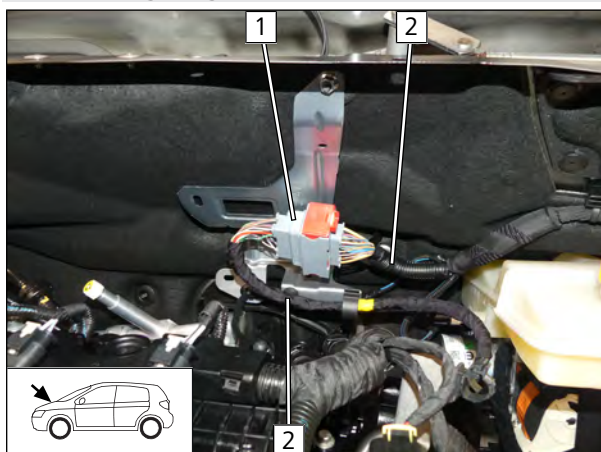

Fig. 43

- 1 Loosen original vehicle connector
- 2 Detach original vehicle wiring harness

Dismantling hoses

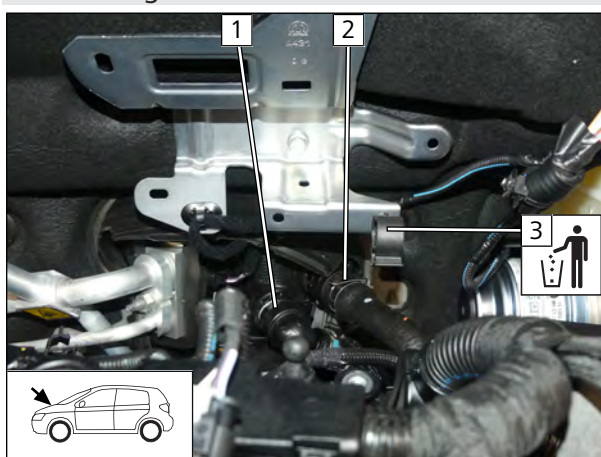

Fig. 44

► Pull off heat exchanger outlet hose 2 and put it aside.

- 1 Pull off heat exchanger inlet hose
- 3 Original vehicle clip

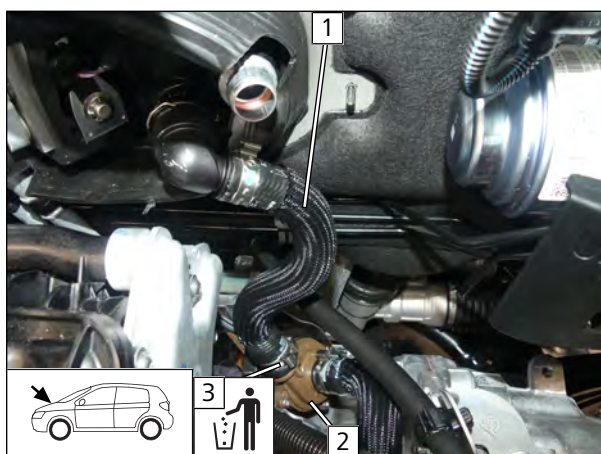

Fig. 45

- 1 Heat exchanger inlet hose
- 2 Original vehicle coolant pump
- 3 Original vehicle clamp



Premounting double non-return valve

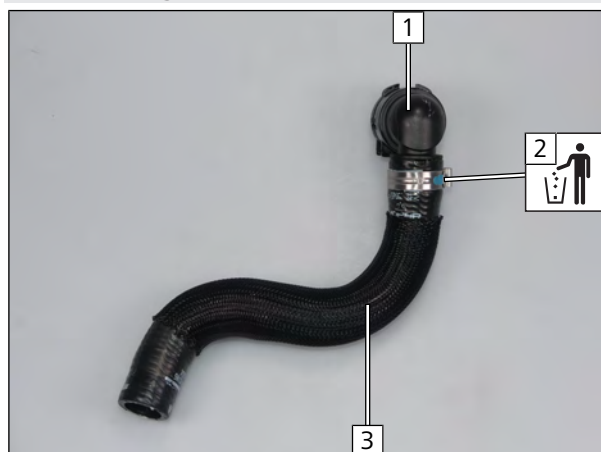

Fig. 46

- 1 Remove heat exchanger inlet coupling (it will be re-used)
- 2 Original vehicle clamp
- 3 Engine outlet hose section

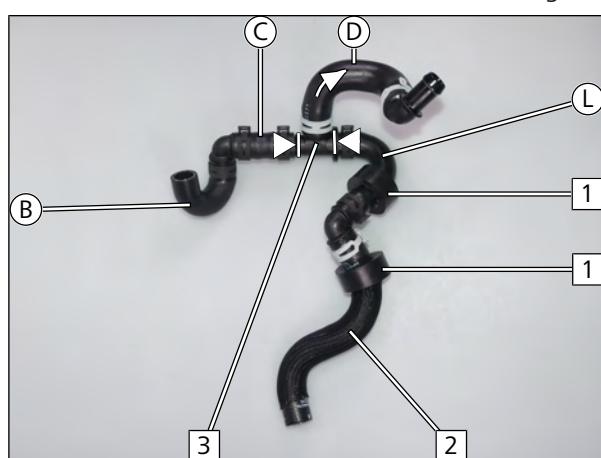

Fig. 47

- 1 Rubber isolator
- 2 Engine outlet hose section
- 3 3x Ø18 double non-return valve

Premounting T-piece

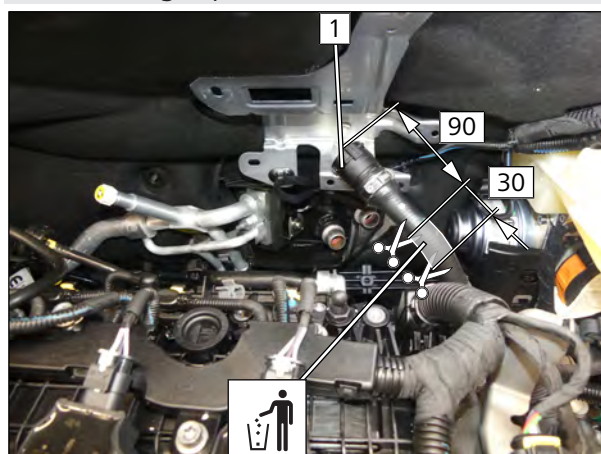

Fig. 48

- 1 Heat exchanger outlet hose section

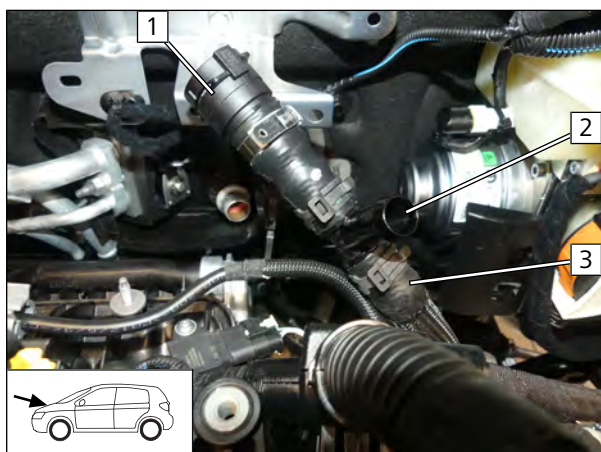

Fig. 49

- 1 Heat exchanger outlet hose section
- 2 3x Ø18 T-piece
- 3 Engine inlet hose section

Preparing coolant pump perforated bracket

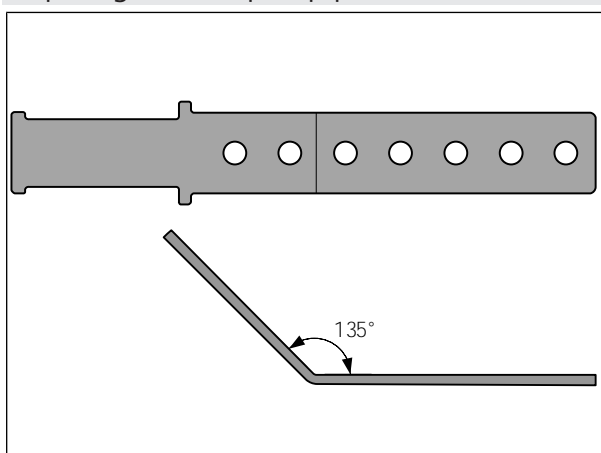

Fig. 50

Premounting coolant pump

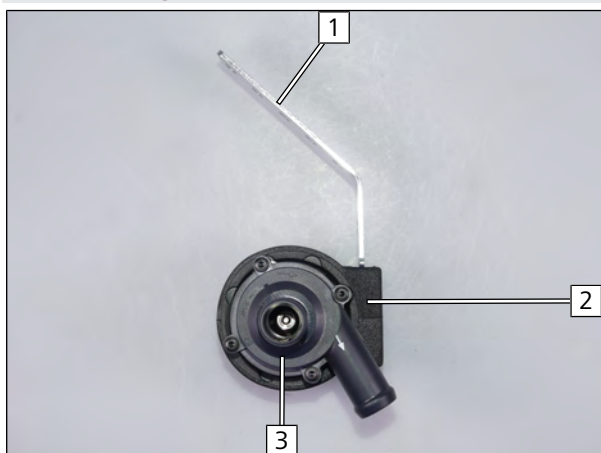

Fig. 51

- 1 Coolant pump perforated bracket
- 2 Coolant pump mount
- 3 Coolant pump



Mounting coolant pump

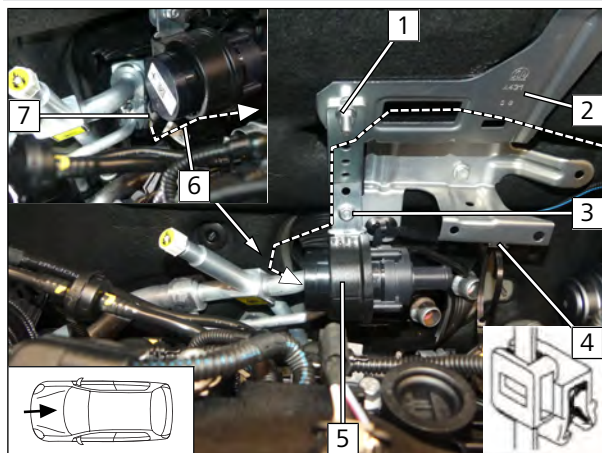

Fig. 52

- 1 M6x20 bolt, large diameter washer, original vehicle bracket, coolant pump perforated bracket, M6 flanged nut
- 2 Original vehicle bracket
- 3 M6x20 bolt, coolant pump perforated bracket, spacer (8), original vehicle hole, large diameter washer, M6 flanged nut
- 4 Edge clip cable tie
- 5 Premounted coolant pump
- 6 Coolant pump wiring harness
- 7 Coolant pump connector

Premounting battery carrier

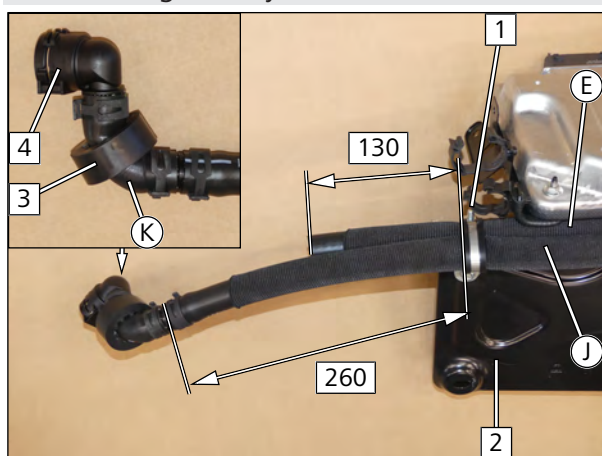

Fig. 53

- 1 Mount Ø38 rubber-coated p-clamp, M6x20 bolt with M6 flanged nut loosely
- 2 Premounted battery carrier
- 3 Ø25 rubber isolator
- 4 Heat exchanger inlet coupling

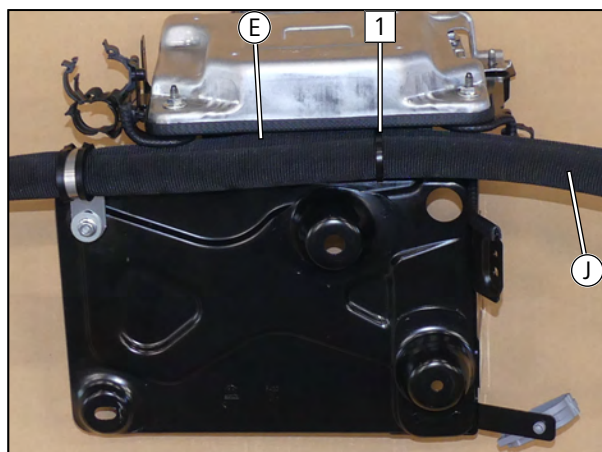

Fig. 54

- 1 Close cable tie



Installing battery carrier

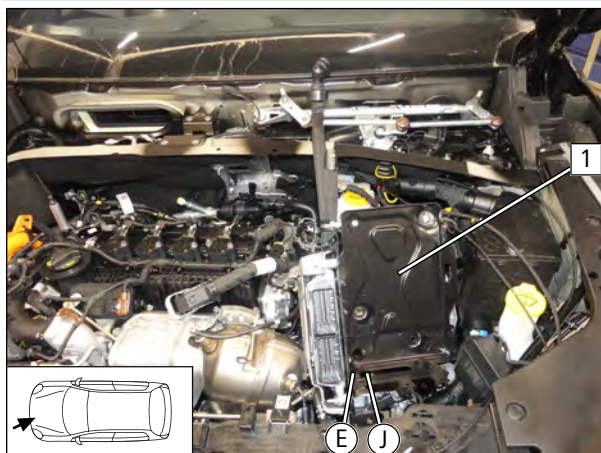

Fig. 55

► Route hoses **E** and **J** to HG installation location.

- 1 Premounted battery carrier

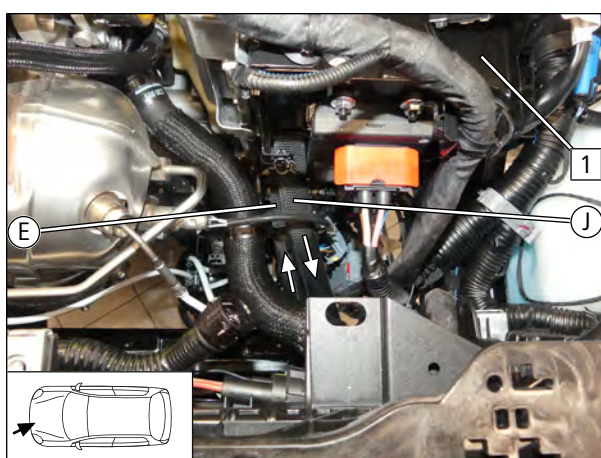

Fig. 56

► Route hoses **E** and **J** to HG installation location.

- 1 Premounted battery carrier

Mounting double non-return valve

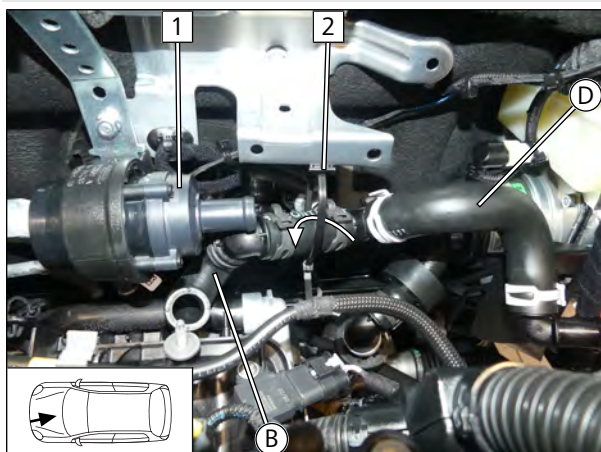

Fig. 57

- 1 Coolant pump
- 2 Edge clip cable tie



Mounting engine outlet hose section

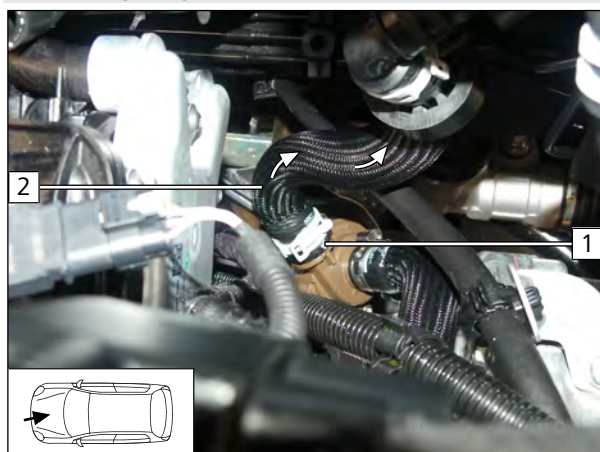

Fig. 58

- 1 Original vehicle coolant pump outlet connection piece
- 2 Engine outlet hose section

Mounting hose (B) on coolant pump

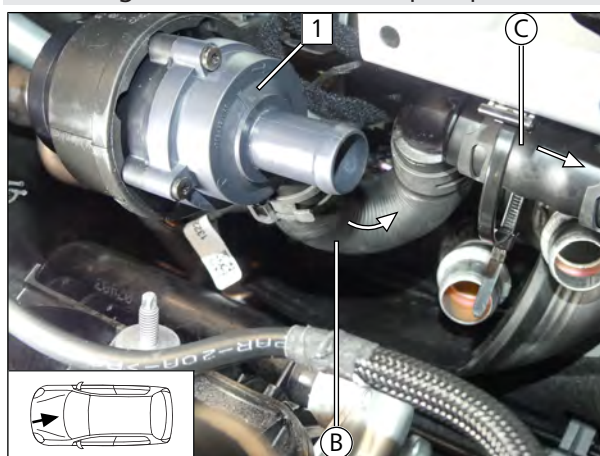

Fig. 59

- 1 Coolant pump

Fixing hose (C)

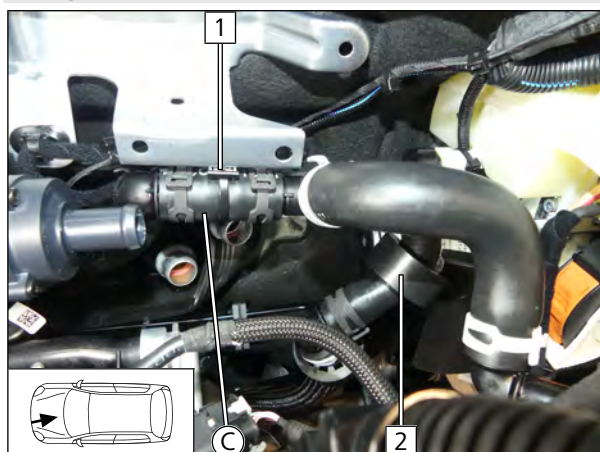

Fig. 60

- 1 Connecting edge clip cable tie
- 2 Aligning rubber isolator



Mounting heat exchanger outlet

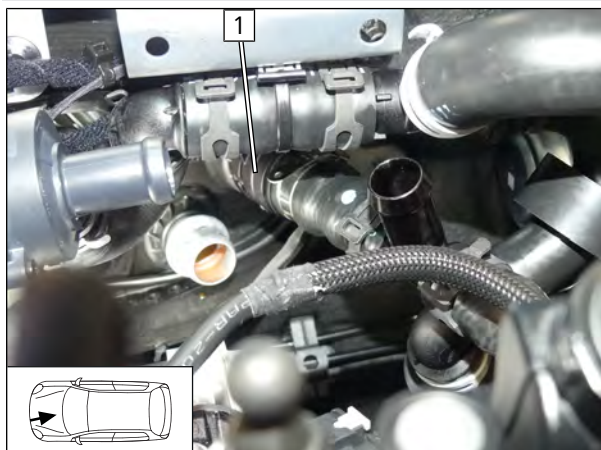

Fig. 61

- 1 Heat exchanger outlet hose section

Mounting heat exchanger inlet coupling 1

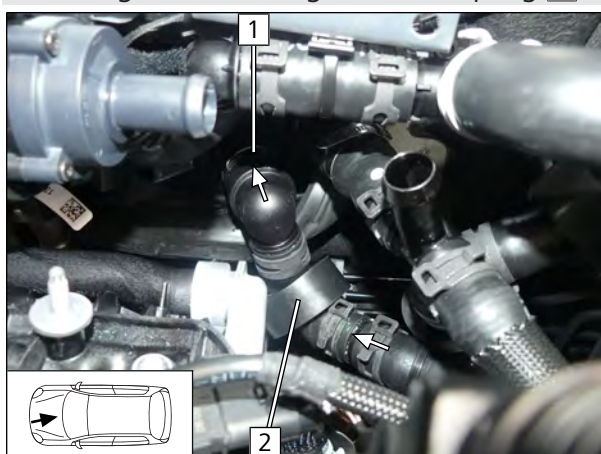

Fig. 62

- 1 Heat exchanger inlet coupling
- 2 Aligning rubber isolator

Mounting hose A

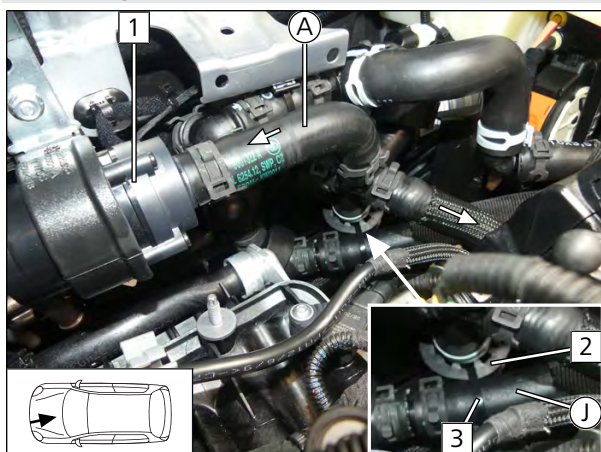

Fig. 63

- 1 Coolant pump
- 2 Premounted rubber isolator
- 3 Cable tie



Reinstalling original vehicle connector

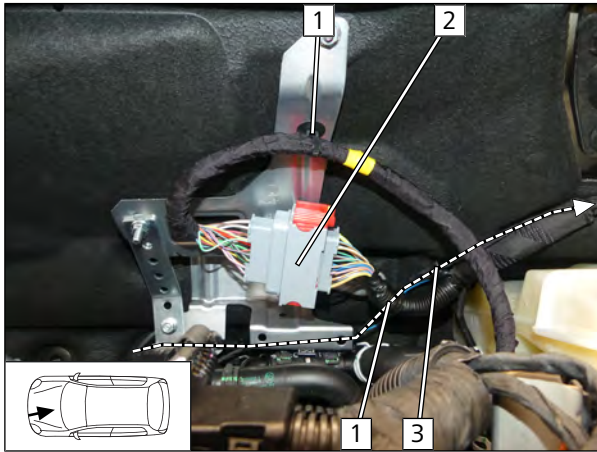

Fig. 64

- 1 Original vehicle clip
- 2 Original vehicle connector
- 3 Coolant pump wiring harness

Connecting hoses (E) and (F) as well as hoses (H) and (J)

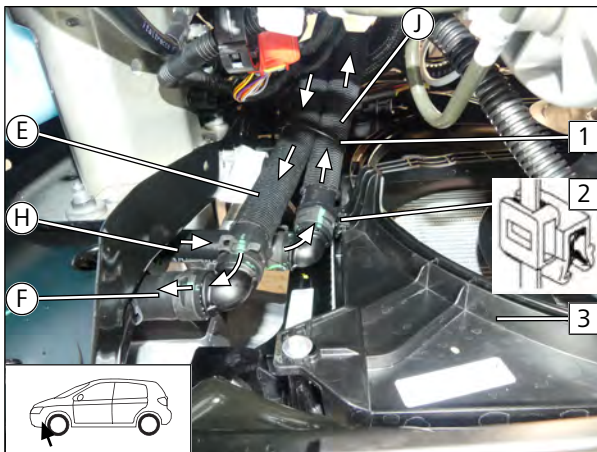

Fig. 65

- 1 Cable tie
- 2 Edge clip cable tie
- 3 Radiator trim

Mounting spacer bracket

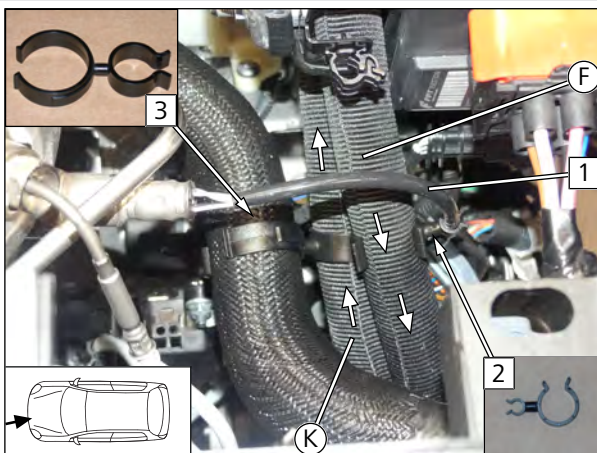
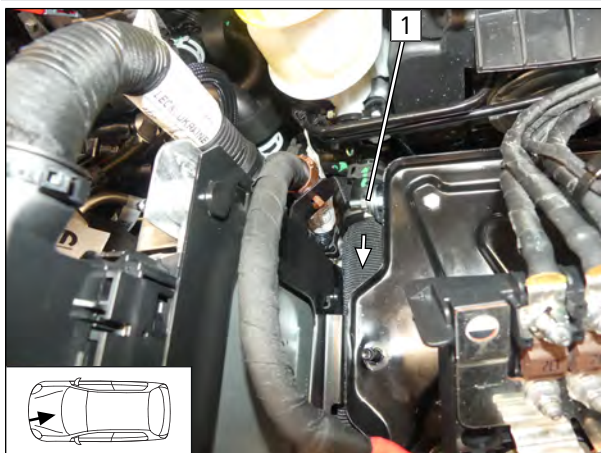

Fig. 66

- 1 Original vehicle wiring harness
- 2 Ø7/22 ASH
- 3 Ø25/37 ASH



Rubber-coated p-clamp



Danger of damage to components

- ▶ Ensure sufficient distance from neighbouring components, correct if necessary.



Tighten all loose screw connections.

- 1** Ø38 rubber-coated p-clamp

Fig. 67



10 Fuel



DANGER

Risk of fire and explosion due to leaking fuel and escaping fuel vapours.

The incorrect installation of the fuel extractor can cause damage and fire.

- ▶ Avoid electrostatic discharges and open fire
- ▶ When working on the fuel system, ensure sufficient ventilation and bleeding
- ▶ Open the fuel tank cap of the vehicle
- ▶ Ventilate the fuel tank
- ▶ Re-close the tank lock
- ▶ Catch any fuel running off with an appropriate container



Danger of damage to components

- ▶ Install fuel line and fuel pump wiring harness so that they are protected against stone impact
- ▶ Provide rub protection for fuel line and wiring harness in areas where there are sharp edges

Dismantling fuel pump connector X7

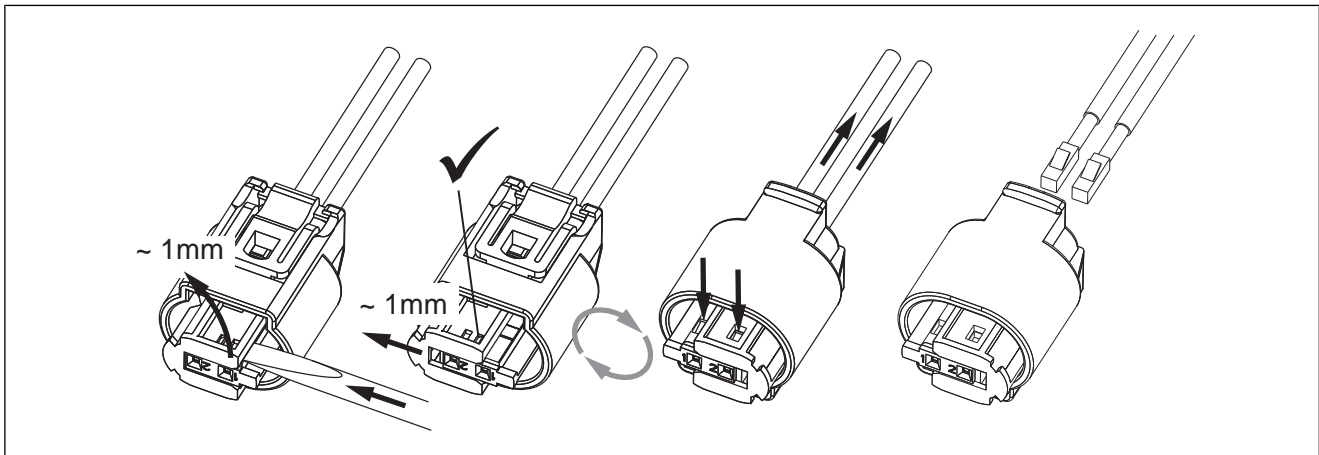

Fig. 68

10.1 Connecting and routing fuel line

Connecting heater

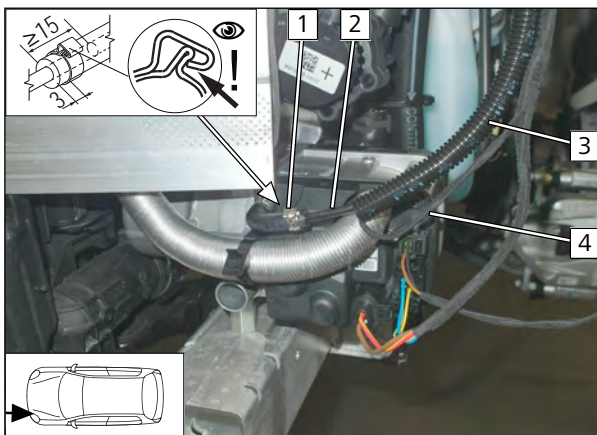

Fig. 69

- 1 Ø10 clamp
- 2 Fuel line in corrugated tube
- 3 Corrugated tube
- 4 Fuel pump wiring harness in corrugated tube



Routing and fastening fuel line

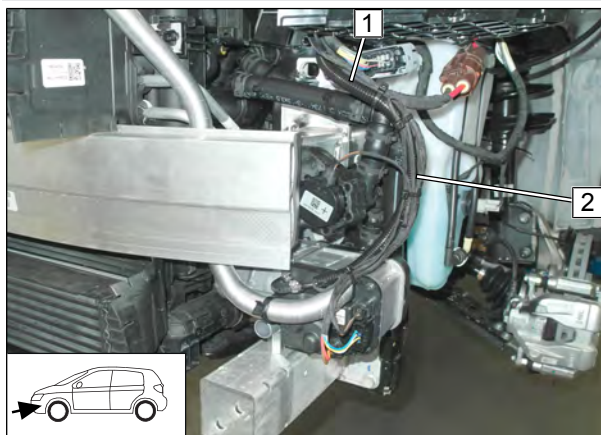

Fig. 70

- 1 Corrugated tube with fuel pump wiring harness and fuel line
- 2 Fasten corrugated tube as well as heater and coolant pump wiring harnesses with cable ties

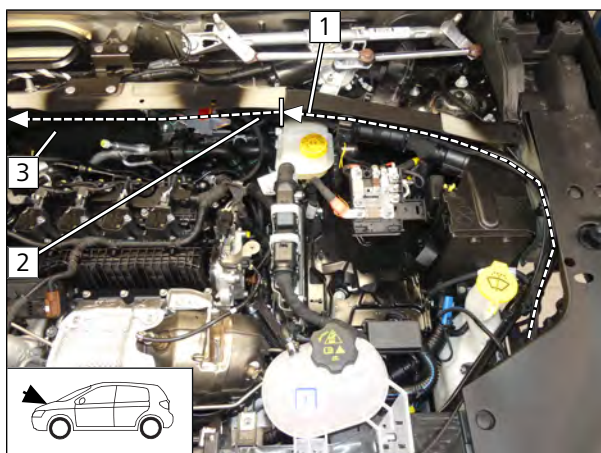

Fig. 71

- ▶ Fasten corrugated tube 1 with fuel pump wiring harness and fuel line with cable ties
- ▶ Route fuel pump wiring harness and fuel line 2 behind insulation mat 3.

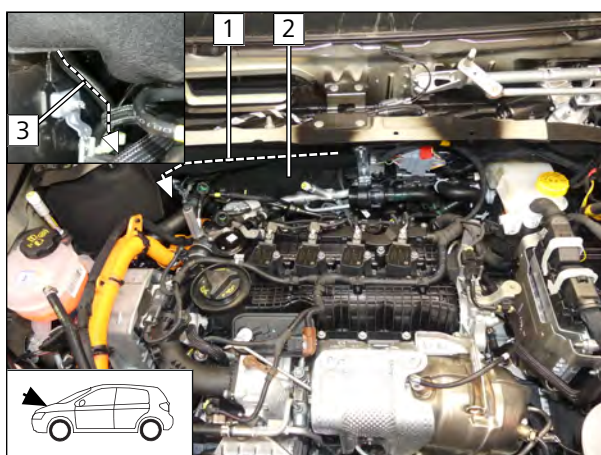

Fig. 72

- ▶ Route fuel pump wiring harness and fuel line 1 behind insulation mat 2.
- ▶ Route corrugated tube 3 with fuel pump wiring harness and fuel line to the underbody.

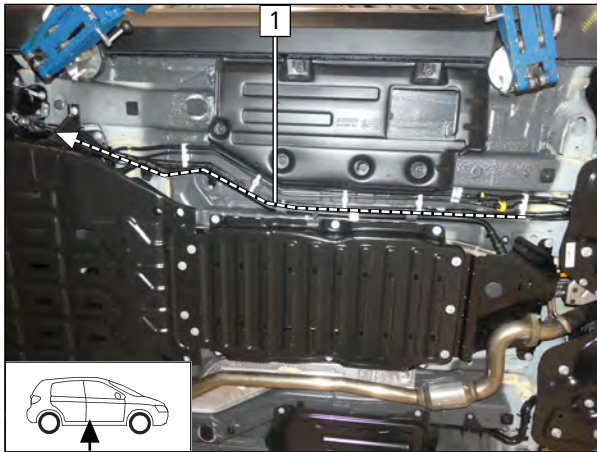

Fig. 73

► Fasten fuel pump wiring harness and fuel line **1** to original vehicle brake line with cable ties

10.2 Mounting fuel pump

Bending fuel pump perforated bracket

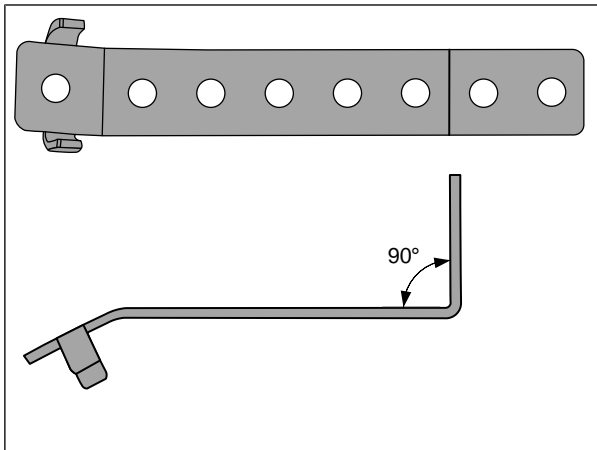

Fig. 74

Premounting fuel pump

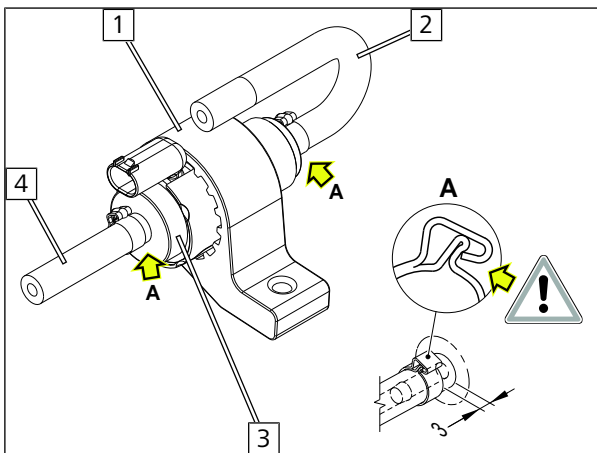

Fig. 75



The alignment of the fuel pump and fuel hoses will be carried out afterwards, during the installation.

- 1** Fuel pump mount
- 2** 180° moulded hose, Ø10 clamp
- 3** Fuel pump
- 4** Hose section, Ø10 clamp

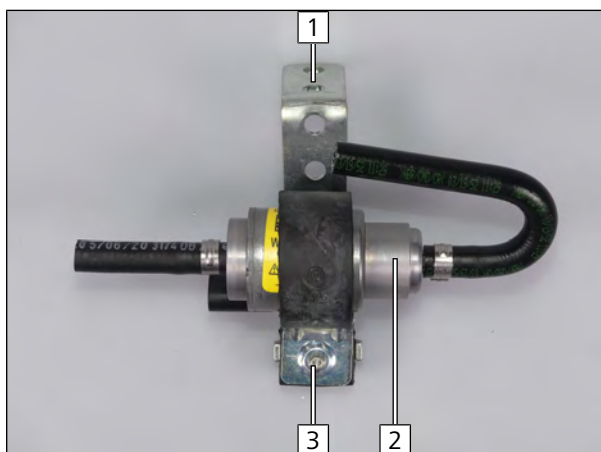

Fig. 76

- 1 Fuel pump perforated bracket
- 2 Premounted fuel pump
- 3 M6x25 bolt, perforated bracket, fuel pump mount, support angle bracket, flanged nut

Mounting fuel pump

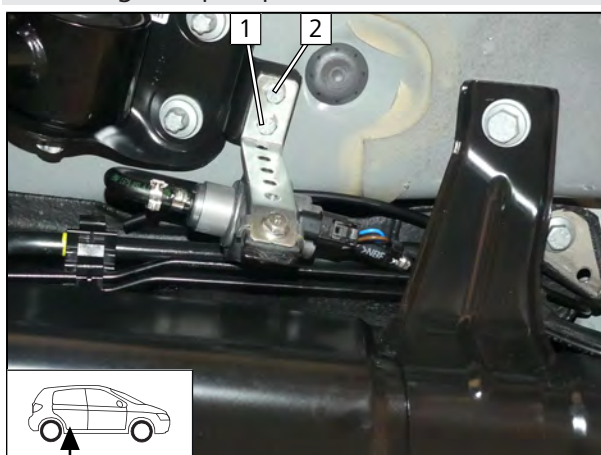

Fig. 77

- 1 M6x20 bolt, fuel pump perforated bracket, original vehicle hole, large diameter washer, flanged nut
- 2 M6x20 bolt, fuel pump perforated bracket, original vehicle hole, flanged nut

Assembling fuel pump connector X7

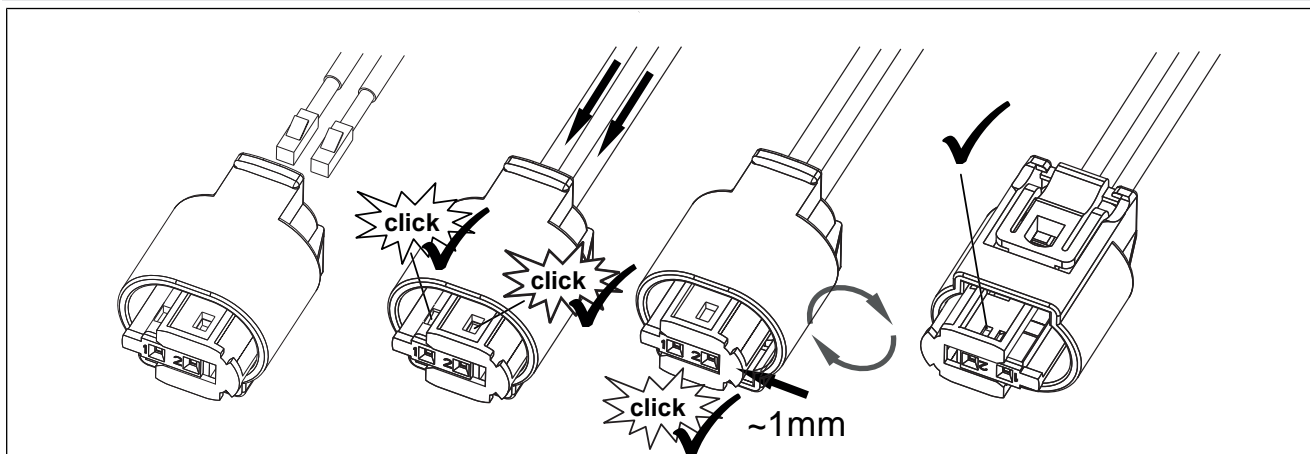

Fig. 78



Connecting fuel line

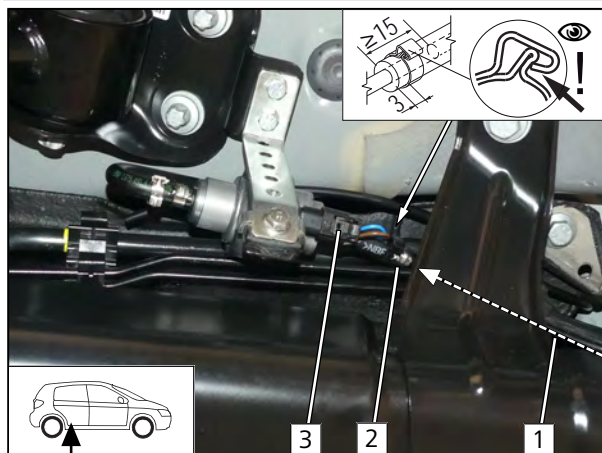

Fig. 79

- 1 HG fuel line
- 2 Hose section, Ø10 clamp
- 3 Fuel pump wiring harness, connector X7 mounted

Removing rear seat



Fig. 80



Further information can be found in the vehicle manufacturer's technical documentation.

- 1 Remove original vehicle bolt

10.3 Mounting tank extracting device

View of drilling template

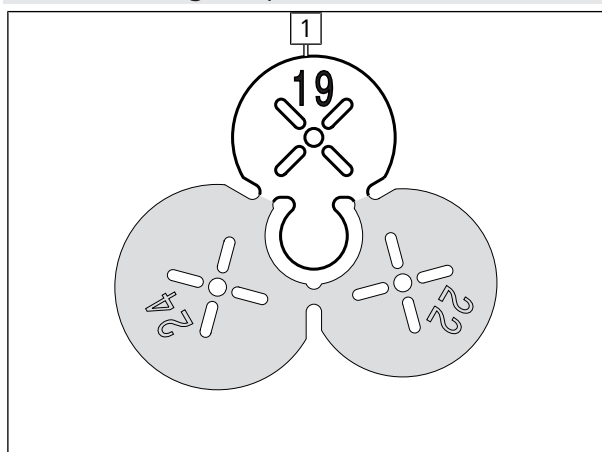

Fig. 81

- 1 19mm dia. drilling template



Copying hole pattern

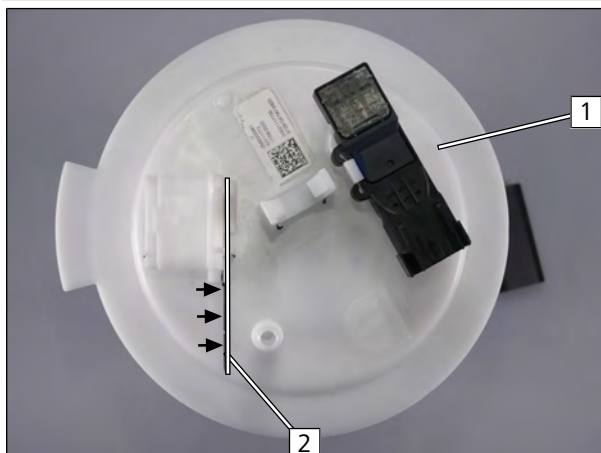

Fig. 82



Dismantle tank fitting **1** according to manufacturer's instructions.

► Draw positioning line **2** for drilling template as shown.

Copying hole pattern

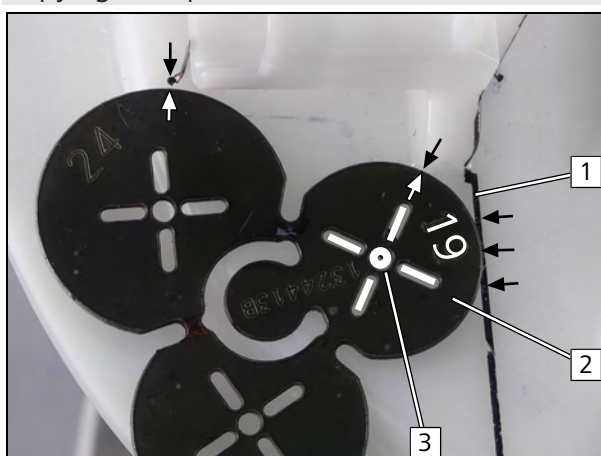

Fig. 83

- 1** Positioning line
- 2** Position $\varnothing 19$ drilling template as shown in fig.
- 3** Hole pattern

Hole for tank extracting device

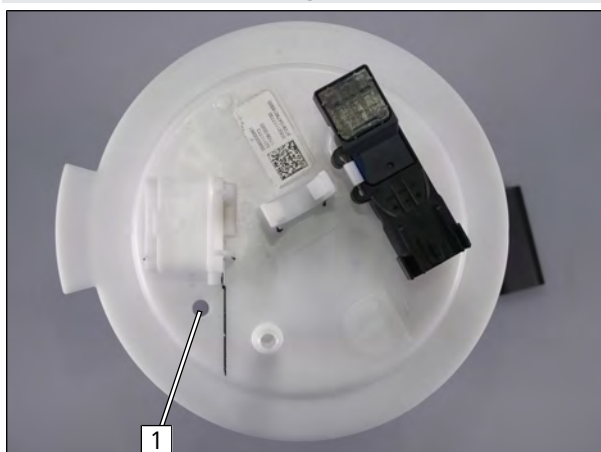

Fig. 84

- 1** $\varnothing 6$ hole



Preparing tank extracting device

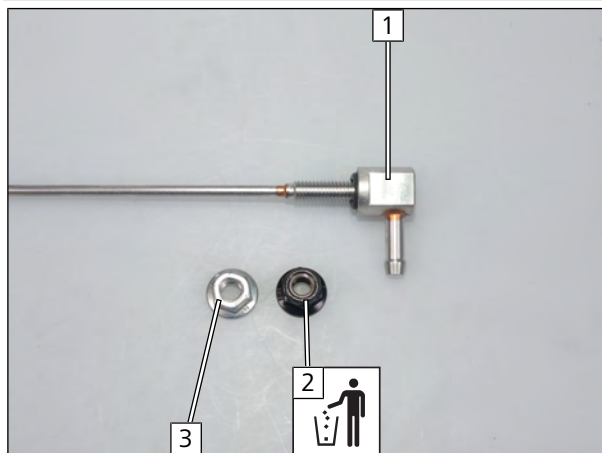

Fig. 85

- 1 Tank extracting device
- 2 Discard original locking nut
- 3 New locking nut

Mounting tank extracting device

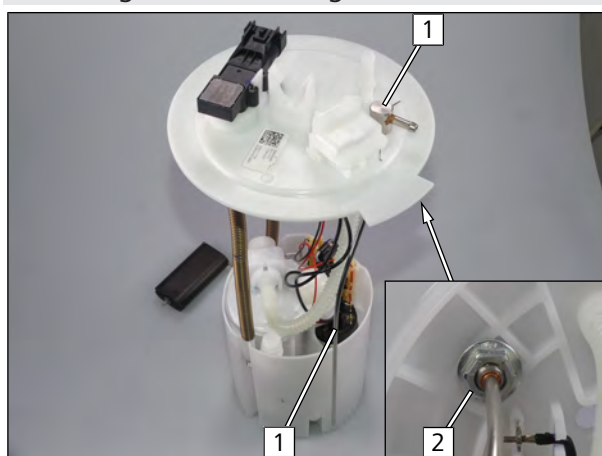

Fig. 86

F Observe the installation instructions of the tank extracting device.

► Bend tank extracting device **1** according to template and cut to length. Insert in hole and align as shown.

- 2 Locking nut

Premounting hose section

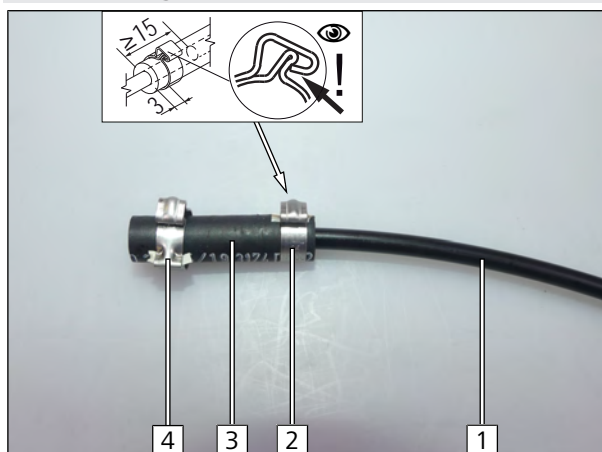

Fig. 87

- 1 Fuel line of tank extracting device
- 2 Ø10 clamp
- 3 Hose section
- 4 Mount Ø10 clamp loosely



Connecting fuel line

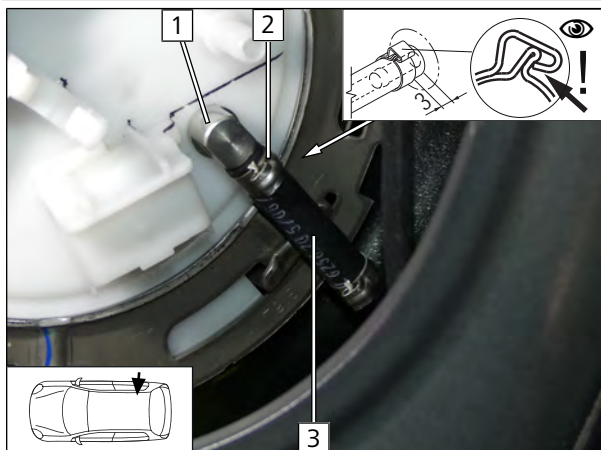

Fig. 88



Mount tank fitting in accordance with manufacturer's instructions.

- 1 Tank extracting device
- 2 Ø10 clamp
- 3 Premounted hose section

Securing fuel line

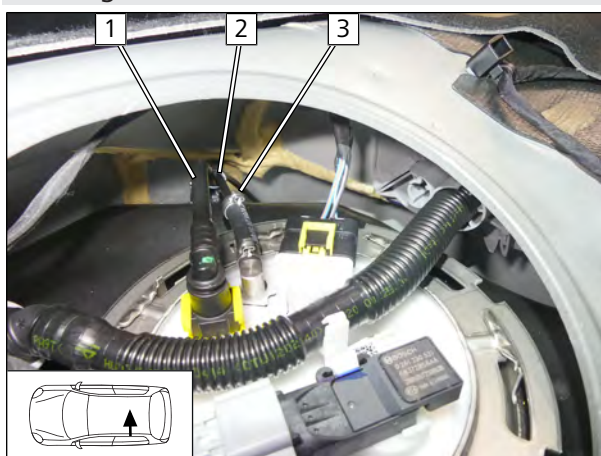

Fig. 89

- 1 Original vehicle fuel line
- 2 Cable tie for tension relief
- 3 Fuel line of tank extracting device

10.4 Fuel pump connection

Connecting fuel pump

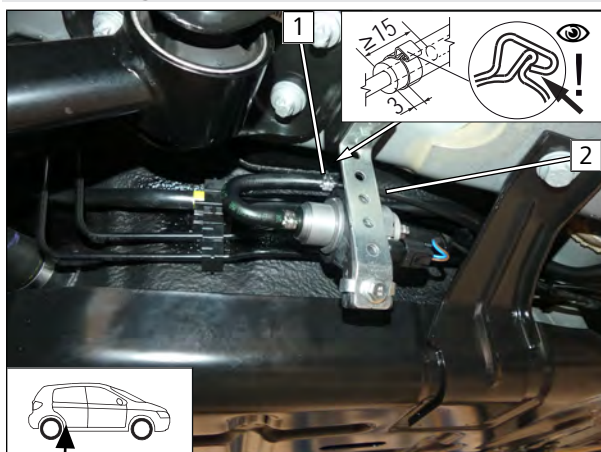

Fig. 90

- 1 Ø10 clamp
- 2 Fuel line of tank extracting device



11 Combustion air

Installing spacer nut

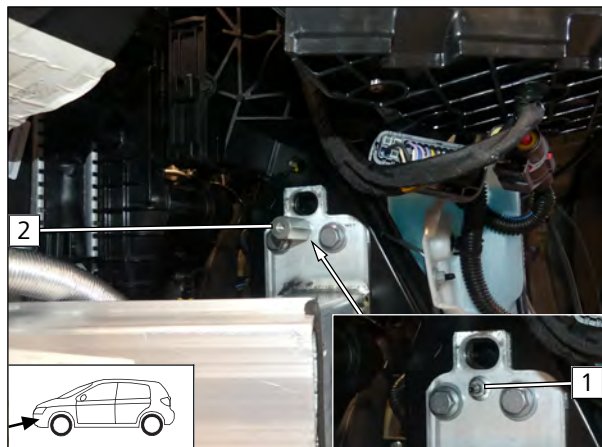

Fig. 91

- 1 Remove and discard original vehicle nut
- 2 M6x40 spacer nut, original vehicle stud bolt

Premounting combustion air intake silencer

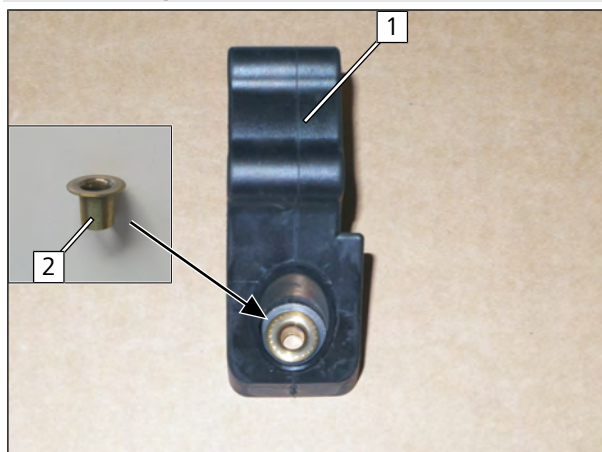

Fig. 92



Observe the installation instructions of the combustion air intake silencer.

- 1 Combustion air intake silencer mount
- 2 Tubular rivet



Fig. 93

- 1 Combustion air intake silencer
- 2 Combustion air intake silencer mount



Mounting combustion air intake silencer

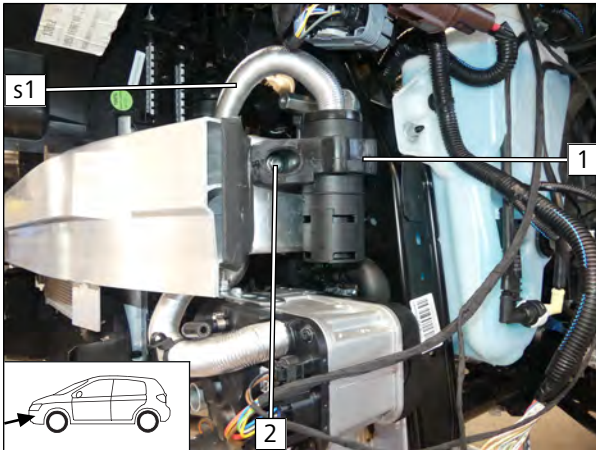

Fig. 94

- 1 Combustion air intake silencer, premounted
- 2 M6x25 bolt, spring lock washer, combustion air intake silencer mount, rivet nut

Mounting p-clamp

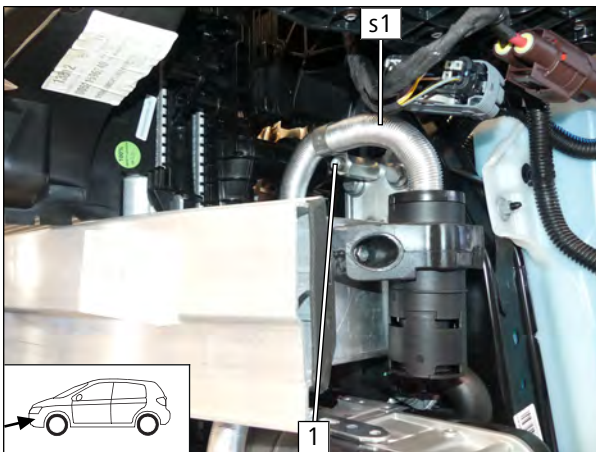

Fig. 95

- 1 M6x20 bolt, spring lock washer, Ø25 p-clamp, spacer nut



12 Exhaust

Preparing exhaust pipe

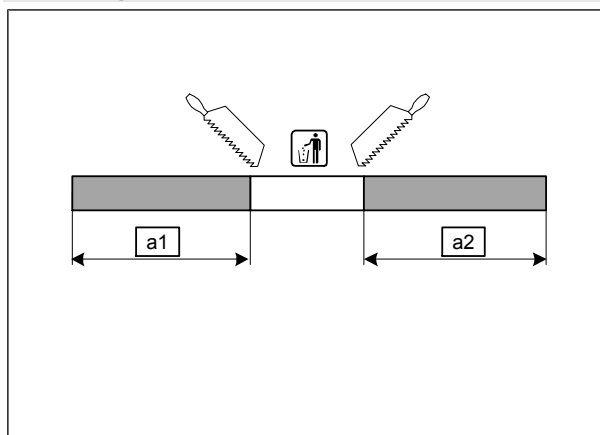

a1 170

a2 190

Fig. 96

Mounting exhaust silencer

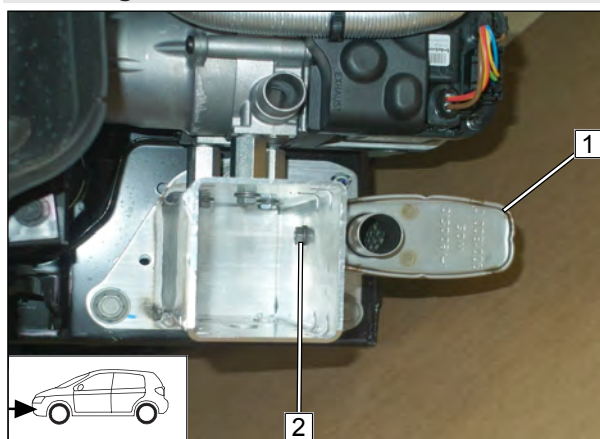

1 Exhaust silencer

2 M6x16 bolt, spring lockwasher

Fig. 97

Mounting exhaust pipe **a1**

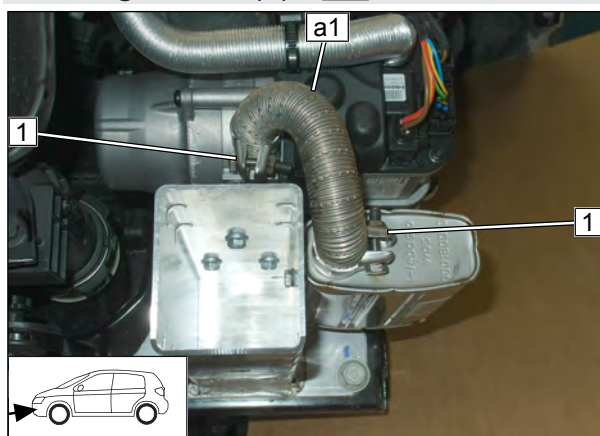

1 Hose clamp

Fig. 98



Mounting exhaust pipe **a2**

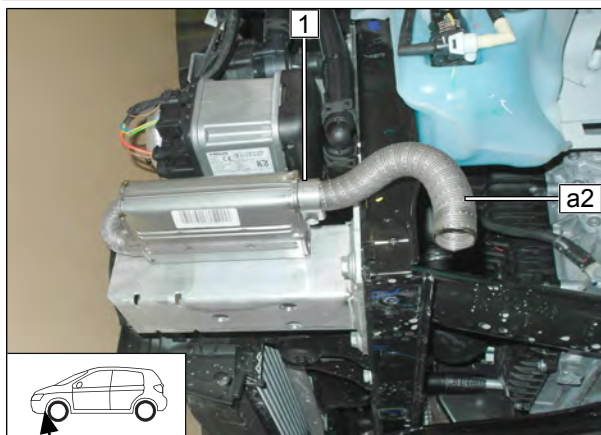

Fig. 99

1 Hose clamp

Remove bumper trim piece



Fig. 100

1 Bumper trim piece

Adapting bumper trim piece

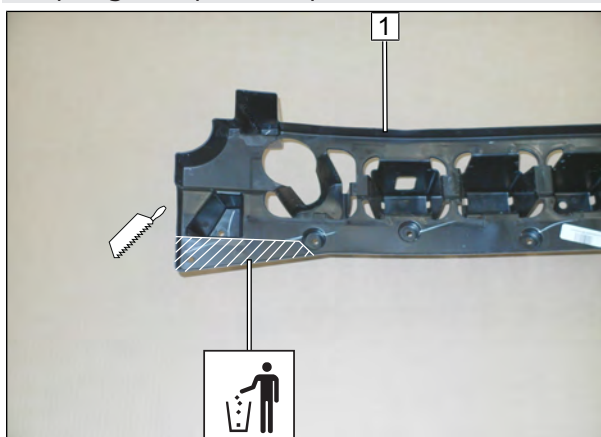

Fig. 101

► Cut out marked area of trim piece **1** as shown.



Mounting bumper trim piece

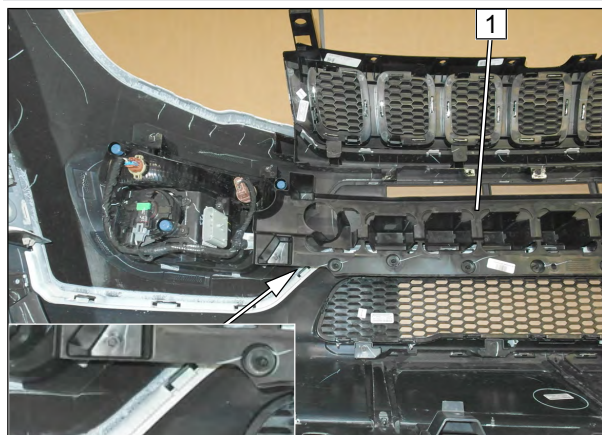

Fig. 102

- 1 Bumper trim piece

Affixing heat protection

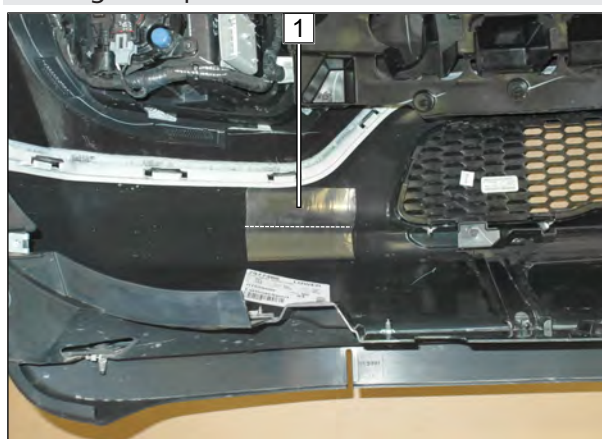

Fig. 103

- Split heat protection 1 and affix as shown.

Copying hole pattern

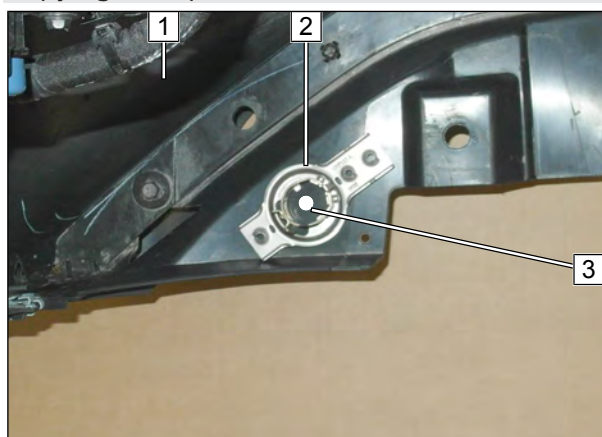

Fig. 104



Observe the EFIX installation instructions.

- Work steps E1.1, E1.2

- 1 Bumper
- 2 Exhaust end fastener
- 3 Hole pattern, hole



Copying hole pattern

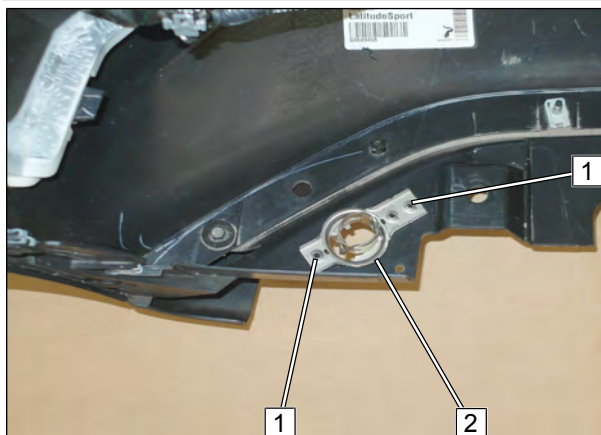

Fig. 105

► Work step E3

- 1 Hole pattern
- 2 EFIX

Drilling holes in underride protection



Fig. 106

► Work step E4

- 1 Hole

Mounting EFIX

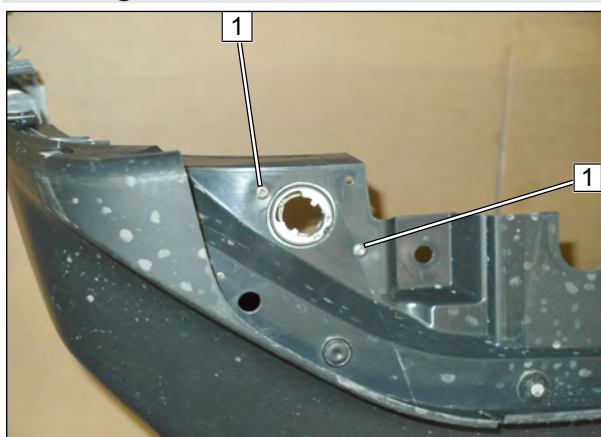

Fig. 107

► Work step E5

- 1 5x13 self-tapping screw



Mounting exhaust pipe **a2**

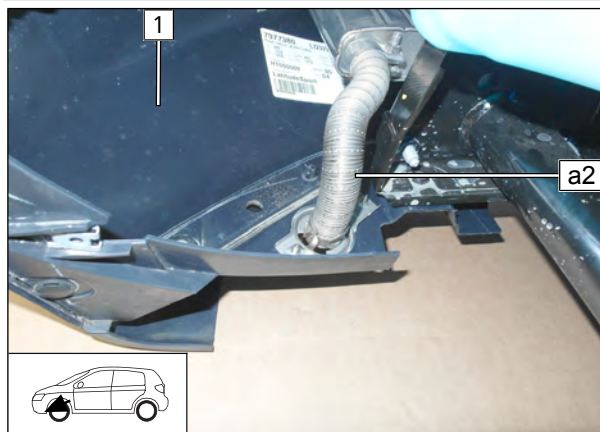

Fig. 108

- ▶ Work steps E6-E8
- ▶ Mount bumper **1**.

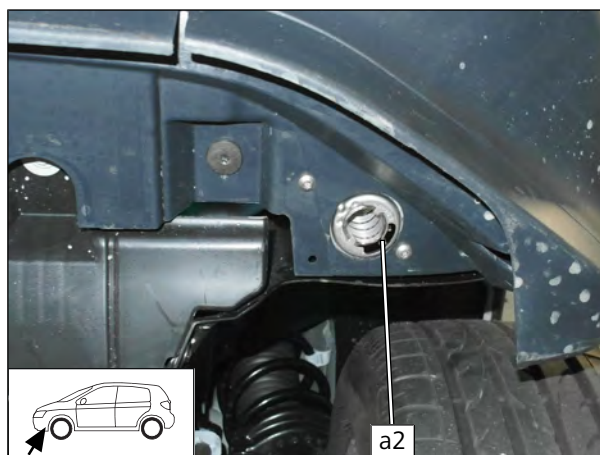

Fig. 109

- ▶ Work steps E6-E8

Checking distance

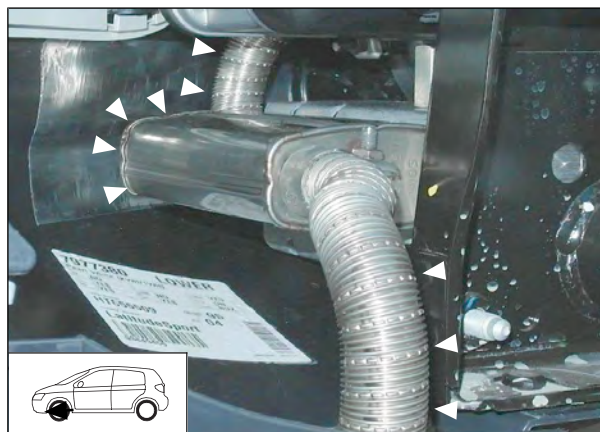

Fig. 110



Danger of damage to components

- ▶ Ensure sufficient distance from neighbouring components, correct if necessary.



13 Electrical system of passenger compartment

13.1 Air-conditioning control

Integrate the air-conditioning control as per the separate installation documentation:



'**Webasto Comfort**' installation documentation for Jeep Compass air-conditioning control



14 Final work



Further information can be found in the vehicle manufacturer's technical documentation.

- ▶ Mount removed parts in reverse order.



▶ Check all hoses, clamps and all electrical connections for firm seating.

▶ Insulate and tie back loose lines

▶ Spray heater and electrical components with anti-corrosion wax (Tectyl 100K).

▶ Connect the battery.



Only use manufacturer-approved coolant.

- ▶ Fill and bleed the coolant circuit according to the vehicle manufacturer's specifications.



Further information can be found in the general installation and operating instructions of the Webasto components.

▶ Program MultiControl CAR, teach Telestart transmitter

▶ If the fan function or A/C control panel settings need to be checked, see the installation documentation in the additional kit 'Webasto Comfort' A/C control, section 'Final work'

▶ Initial start-up and function check

▶ Affix 'Switch off parking heater before refueling' caution label in area of filler neck

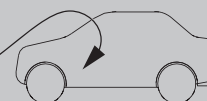
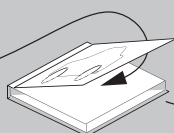
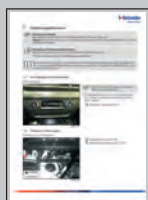
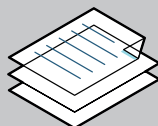

These are the original instructions. The German language is binding.
You can request your language if it is missing. The telephone number of each country can be found in the Webasto service centre leaflet or the website of the respective Webasto representative of your country.

© Copyright 2021 - The contents of this document, including but not limited to text, photographs and graphics, are protected by copyright. All rights, including reproduction, publication, editing and translation in any way, shape or form, are reserved by Webasto.

Ident No. 1328404A_EN • 02/21 • Errors and omissions excepted • © Webasto Thermo & Comfort SE • 2021

Webasto Thermo & Comfort SE
Postfach 1410
82199 Gilching
Germany

Company address:
Friedrichshafener Str. 9
82205 Gilching
Germany

Technical Extranet: <https://dealers.webasto.com>



WWW.WEBASTO.COM



15 Tank extracting device template

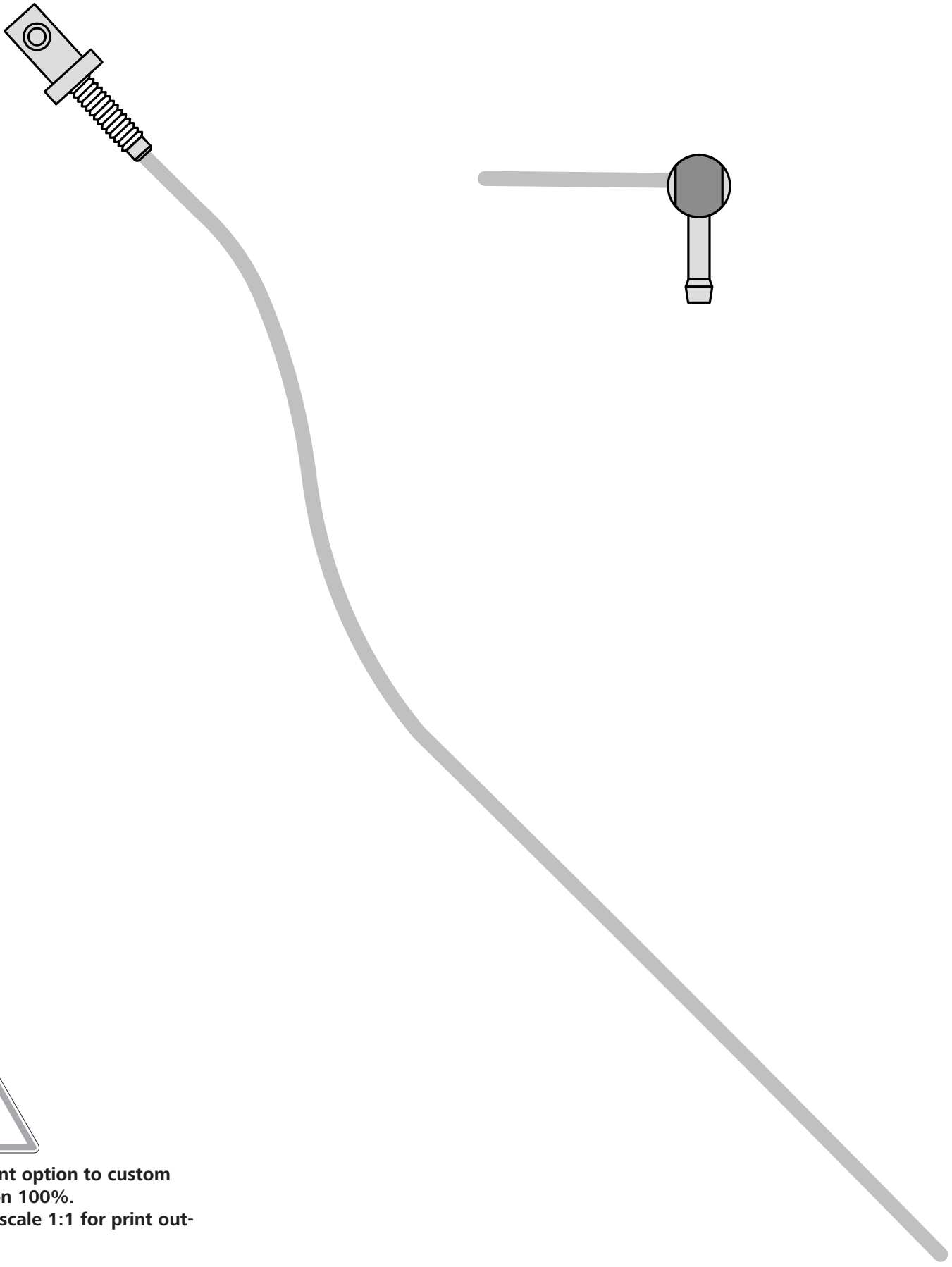

**Set print option to custom scale on 100%.
Check scale 1:1 for print output.**

