

Water Heater Unit



Feel the drive

Thermo Top E Additional heating

00 0003

Thermo Top C Additional heating

00 0002

Thermo Top P Additional heating

00 0104

Installation instructions

Peugeot 607

2.7 I HDI

From model year 2005

For left-hand drive vehicles only



WARNING!

Hazard warning:

Incorrect installation or repair of Webasto heating systems may cause a fire or result in the emission of carbon monoxide, which can be fatal. Serious or fatal injuries can be caused as a result.

Specialist company training, technical documentation, specialized tools and equipment are required to install and repair Webasto heating and cooling systems.

NEVER attempt to install or repair Webasto heating or cooling systems if you have not successfully completed the company training and thereby acquired the required technical skills or if you do not have access to the required technical documentation, tools and equipment needed to carry out correct installation and repairs.

ALWAYS follow all Webasto installation and repair instructions and observe all warning instructions.

Webasto does not accept any liability for defects and damage that are attributable to an installation by untrained staff.

Table of Contents

Validity	2	Preparing the installation location	12
Heater Unit / Installation Kit	3	Installing the heater unit	13
Foreword	3	Fuel connection	15
General Instructions	3	Water connection	17
Special Tools	3	Combustion air	21
Explanatory Notes on the Document	4	Exhaust System	22
Preliminary Work	5	Final work	24
Heater Unit Installation Location	5	Operating instructions for the end customer	25
Preparing the electrics	6	Bracket for Template	26
Connection of electrics	8	Tank mounting template	27
Blower control	9	Tank extracting device template	28

Validity

Manufacturer	Model	Type	EG-BE No. / ABE
Peugeot	607	Z9	e2 * 98 / 14 * 0199 * ...

Engine type	Engine model	Power in kW	Engine capacity in cm ³
UHZ	Diesel	155	2720

Vehicle and engine types as well as equipment variants, which are not listed in these installation instructions, have not been tested. Installation according to these installation instructions may, however, be possible.

The installation location of a time switch and summer / winter switch should be confirmed with the end customer before installation.

Heater Unit / Installation Kit

Amount	Description	Order no.:
1	Commercial supply of required control	See price list
1	Installation kit for Peugeot 607 2.7 I HDI	1303794A

Recommended heater unit for the relevant vehicle class:

Vehicle	Heater unit
Compact car	Thermo Top E
Mid-class, station wagon	Thermo Top C
Luxury, van, off-roader	Thermo Top P

Select the heater unit based on the size of the vehicle passenger compartment and the customer's comfort requirements.



Foreword

These installation instructions apply to vehicles Peugeot 607 with 2.7 I HDI engines – re. validity, see page 2 – from model year 2005 and later, assuming technical modifications to the vehicle do not affect installation, any liability claims excluded. Depending on the vehicle version and equipment, modifications may be necessary during installation with respect to these installation instructions.

However, the stipulations in the "installation instructions" and "operating and maintenance instructions" for the *Thermo Top C/P/E* are to be observed in any event.

The corresponding rules of technology and any information from the vehicle manufacturer should be observed during the installation work.

General Instructions

Installation should be carried out according to the general, standard rules of technology. Unless specified otherwise, fasten hoses, lines and cable harnesses to original vehicle lines and cable harnesses using cable clips.

Sharp edges should be fitted with edge protectors (split open plastic hose).

Spray unfinished body areas, such as for example bore holes, with anti-corrosion wax (Tectyl 100K, Order No. 111329)!

Special Tools

- Torque spanner for 2.0 - 10 Nm
- Vice-grip wrench
- Riveting nut tool

Explanatory Notes on the Document

To provide you with a quick overview of the individual working steps, you will find an identification mark on the outside top right corner of the page in question.

Mechanical work

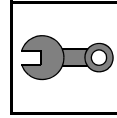

Electrical connection

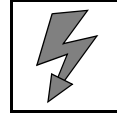

Water connection

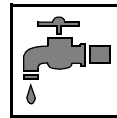

Fuel connection

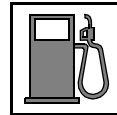

Exhaust system

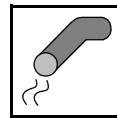

Combustion air

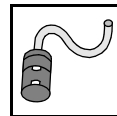

Special features are highlighted using the following symbols:



Specific risk of injury or fatal accidents.



Specific risk of damage to components.



Specific risk of fire or explosion.



Reference to general installation instructions of Webasto components or to the manufacturer's vehicle-specific documents.



Reference to a special technical feature.



The arrow in the vehicle icon indicates the position on the vehicle and the viewing angle

Preliminary work

WARNING!

- Remove the trunk side panel on the left and disconnect the battery.
- Let off pressure in the cooling system.
- Copy the factory number from the original type label to the duplicate type label.
- Remove years that do not apply from the duplicate label.
- Attach the duplicate label (type label) in the appropriate place.
- Remove the engine cover.
- Remove the engine compartment panelling
- Remove the cover on the central electronics
- Disassemble the wiper arms.
- Remove the cooling water reservoir cover.
- Open the tank cap, ventilate the tank.
- Close the tank cap again.
- Remove the underride protection
- Disassemble the right and left wheel-house panel.
- Remove the bumper.
- Remove the footwell panel on the passenger side.
- Remove the glove compartment.
- Fold back the foot mat/carpet around the A pillar on the left.
- Completely remove the rear seat.

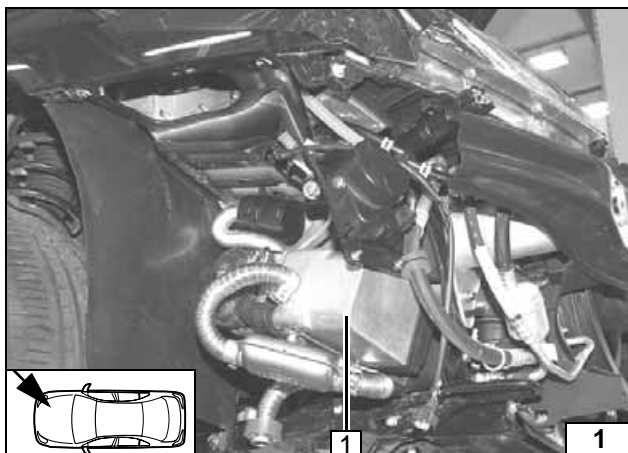

Heater unit installation location

(1) Heater unit

Installation location

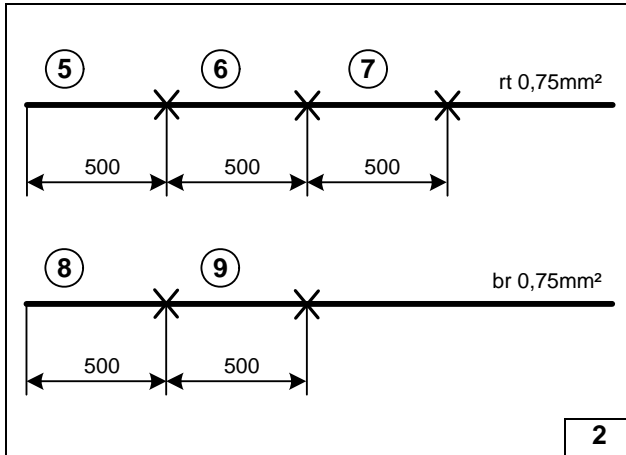

Preparing the Electronics

Cut three ends of 500 mm each **5, 6, 7** from the enclosed red wire.

Cut two ends of 500 mm each **8, 9** from the enclosed brown wire.



Cutting wires into sections

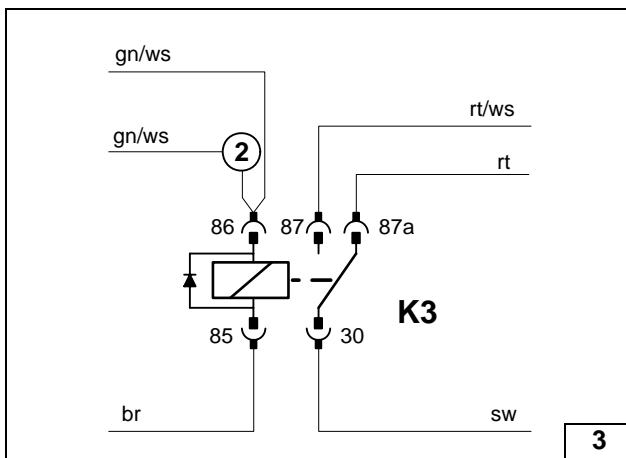

Connect the enclosed green/white (gn/ws) wire **2** with to K3/86.



Preparing the K3 relay

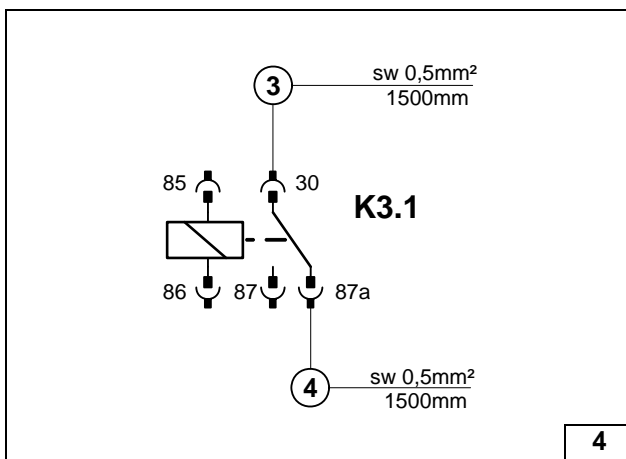

Connect the enclosed black (sw) wire **3, 4** to K3.1/30 und K3.1/87a.

Preparing K3.1 relay

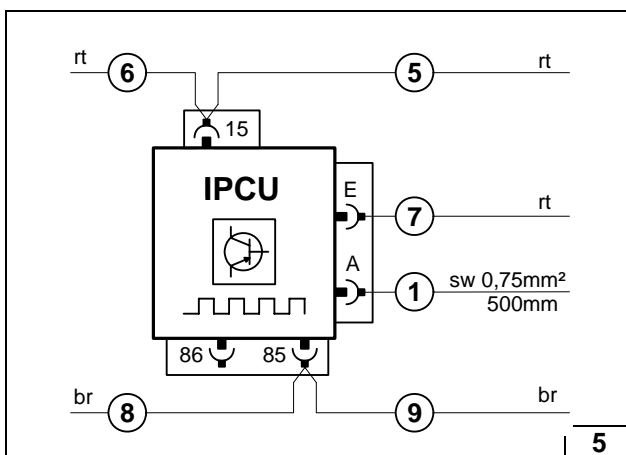

Connect the enclosed black (sw) wire **1** to the IPCU outout. Connect the cut red wires **5, 6, 7** and brown **8, 9**.

Preparing the IPCU.

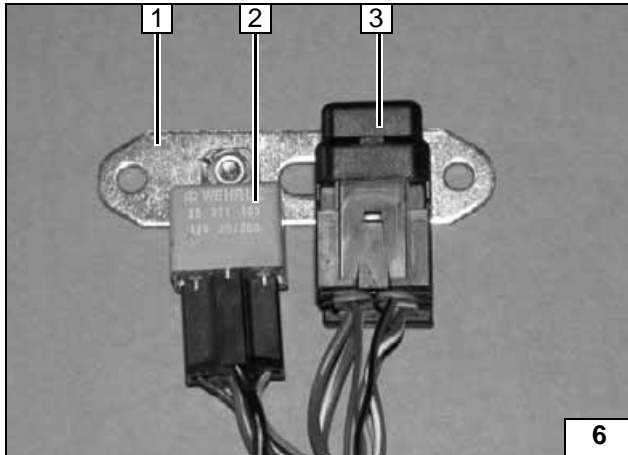

- (1) fastening strap with holes
- (2) relay K3, M5x12 bolt, body washer, flanged nut M5
- (3) blade-type fuse holder retaining plate, M5x12 bolt, body washer [2x], flanged nut M5

Preassembling the Cable Harness

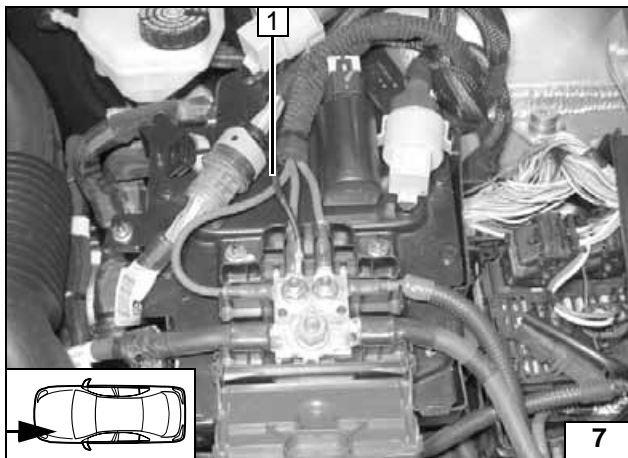

- (1) red wire to positive terminal point with the Ø 8mm cable socket

Connecting the positive wire



Electrical Connections



Assembling the pre-assembled cable harness

Body washer fastening strap and suspension strut mount.

- (1) Pre-assembled cable harness
- (2) Ø 4.8mm bore hole, body washer, 5.5x13 self-tapping screw.
- (3) Flanged nut M6

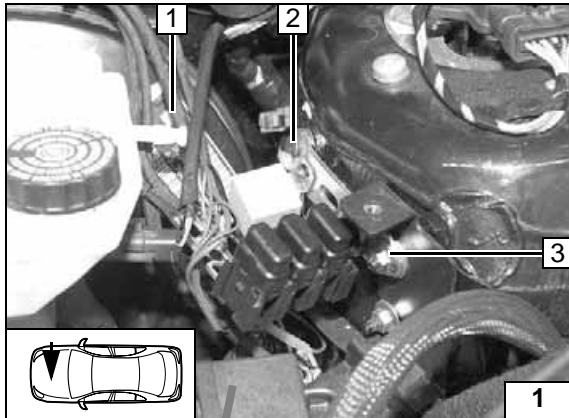

Cable harness duct in the passenger compartment

Before drilling in the interior, fold back insulating mats.

- (1) Ø 18 mm bore hole, protective rubber sleeve
- (2) Blower control cable harness, time switch, additional line (gn/ws) 2 from K3/86.

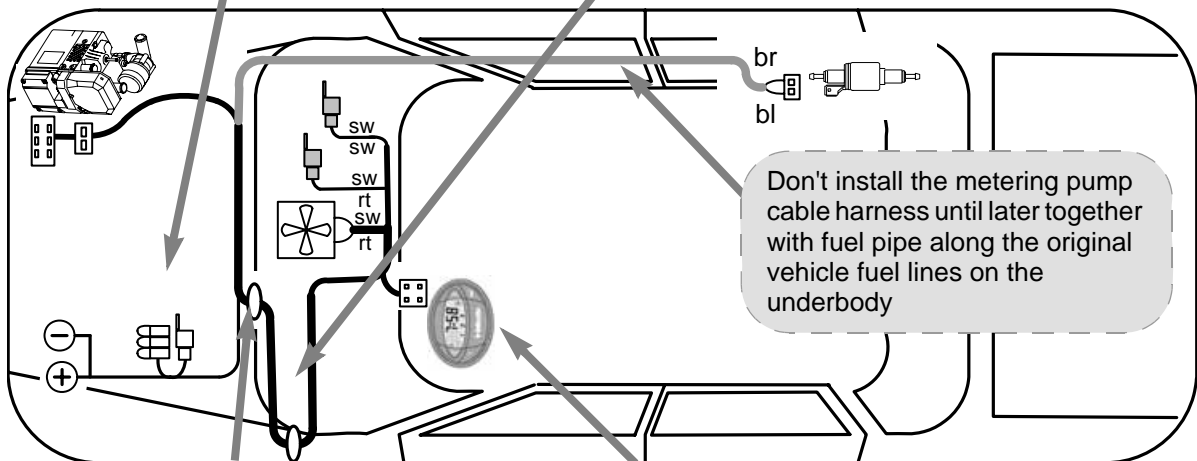
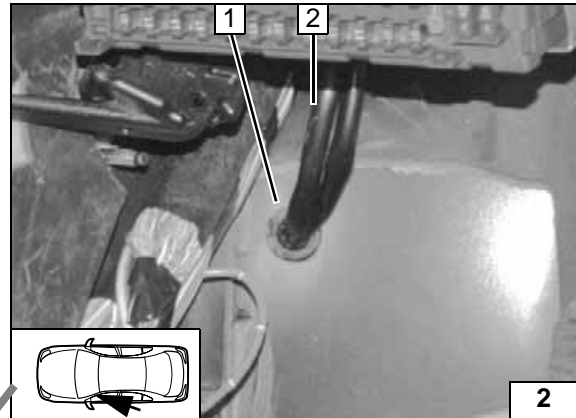

Cable harness installation diagram

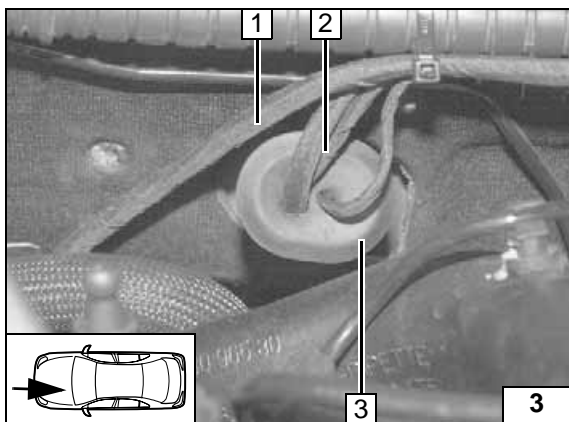

Cable harness duct for cooling water reservoir

- (3) protective rubber sleeve
- (2) Blower control cable harness, time switch, additional line (gn/ws) 2 from K3/86.
- (1) Heater unit cable harness

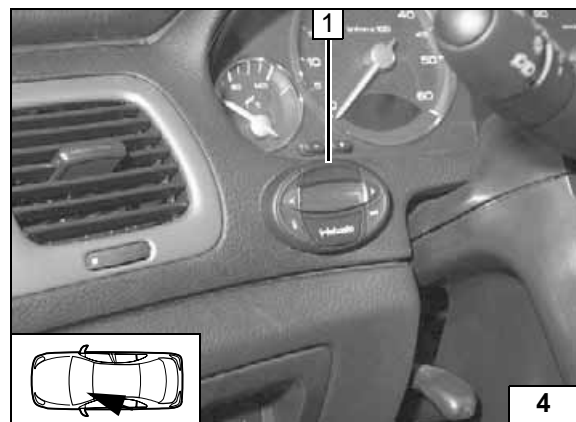

Time switch

- 1 Time switch

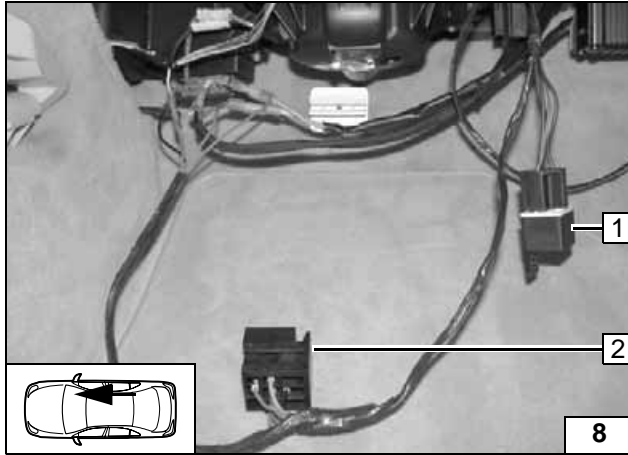

Blower Control

- (1) supplementary relay K 3.1
- (2) IPCU

Installing the Cable Harnesses

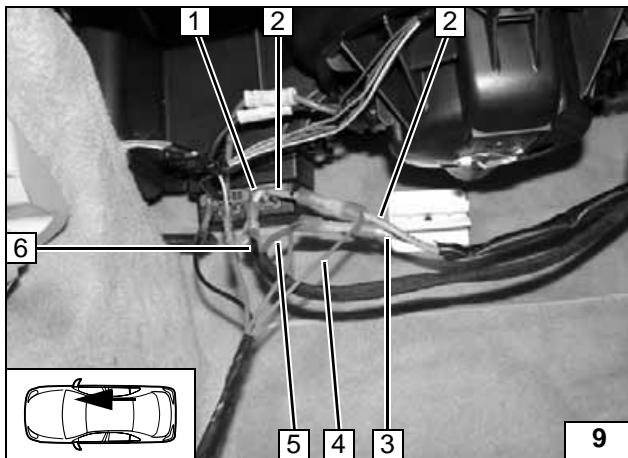

Reconnect according to the circuit diagram.

- (6) black (sw) wire from blower relay K3/30.
- (1) white (ws) wire from original vehicle blower relay pin 5.
- (5) red (rt) wire from blower relay K3/87a
- (3) white (ws) wire from original vehicle blower controller pin 1.
- (2) green/yellow (gn/ge) wire from blower controller (8045) pin 2.
- (4) brown (bn) 9 wire from IPCU/85.



Connection to the blower controller

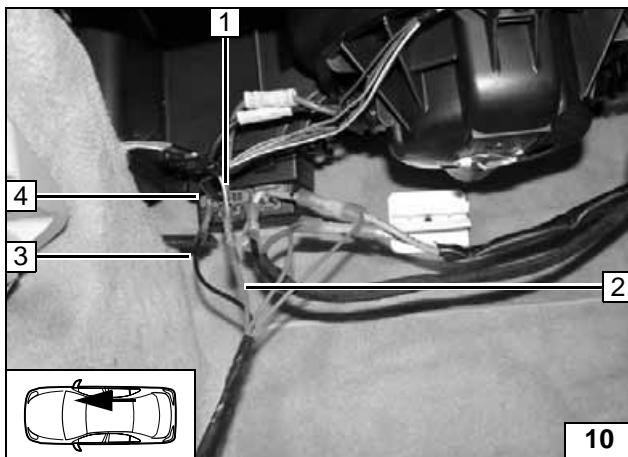

Reconnect according to the circuit diagram.

- (3) black (sw) wire 1 from IPCU/A.
- (4) white (ws) wire from original vehicle blower controller pin 6.
- (2) red (rt) wire 7 from IPCU/E.
- (1) white (ws) wire to air conditioning control pin 6.



Connection to the blower controller

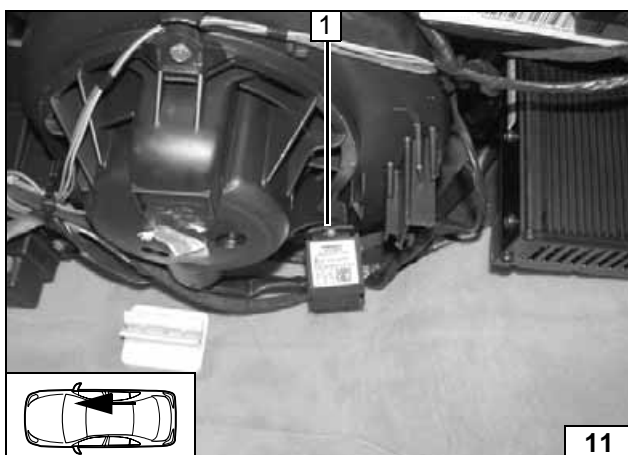

Reconnect according to the circuit diagram. Connect green/white (gn/ws) wire from K3/86 2 to the IPCU/86.

- (1) IPCU to existing blower motor bolt.

Connecting the IPCU

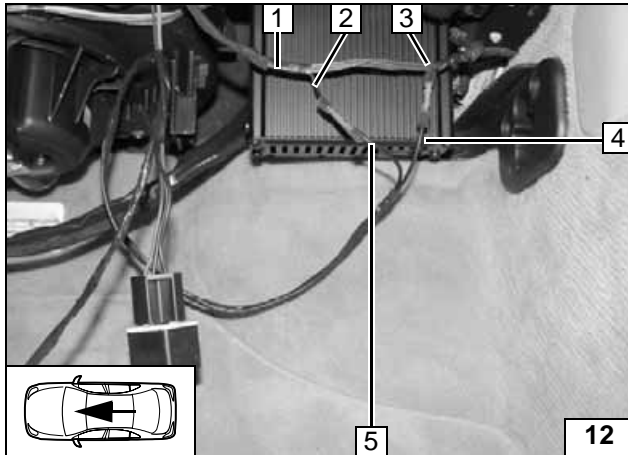

Reconnect according to the circuit diagram.

- (1) time switch cable harness.
- (2) black (sw) wire to time switch.
- (5) black (sw) wire 3 from K3.1/30
- (3) black (sw) wire from heater unit.
- (4) black (sw) wire 4 from K3.1/87a.



Connection K3.1

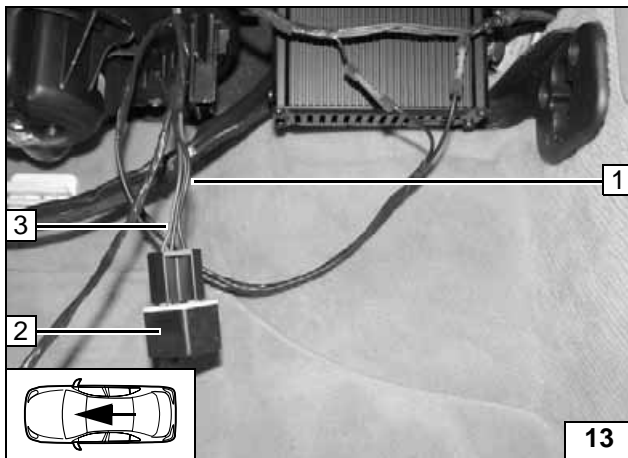

Reconnect according to the circuit diagram. Drill open the shackle from the K3.1 relay to 6 mm.

Run the brown (bn) wire 8 from IPCU/85 and red (rt) wire from 6 from IPCU/86 to the K3.1.

- (2) Supplementary relay
- (1) brown (bn) 8 wire from IPCU/85
- (3) red (rt) wire 6 from IPCU/15.



Connection K3.1

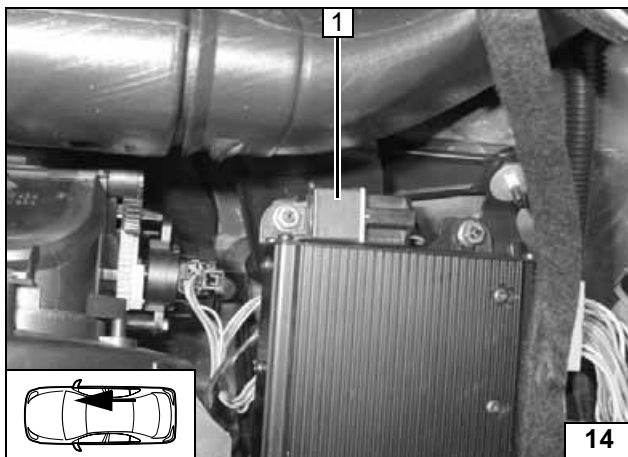

- (1) Relay K3.1 to original vehicle stay bolts, M6 nuts

Assembling K3.1

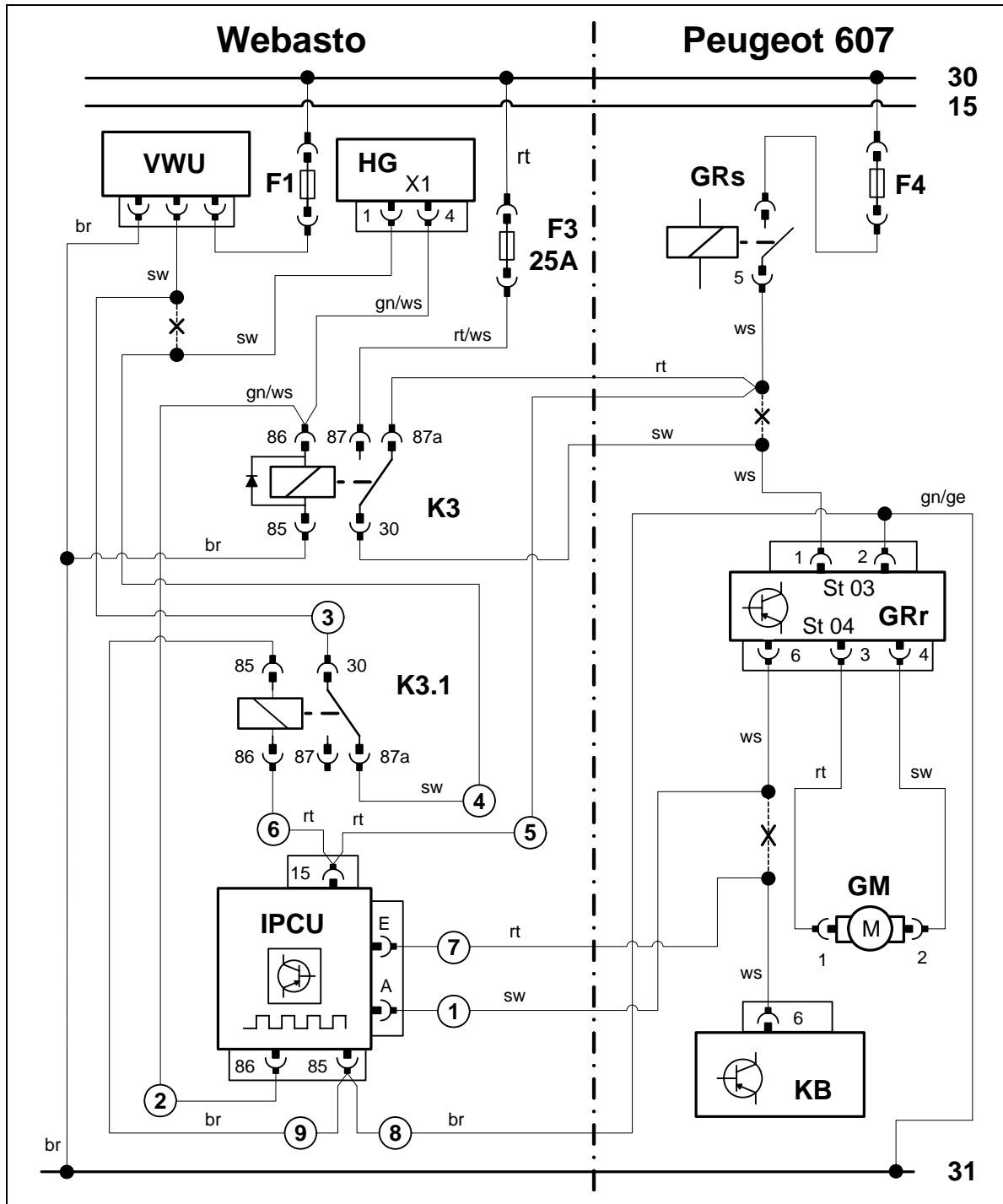

Circuit diagram

Webasto components		Peugeot components		Colours and symbols	
HG	Heater unit TT-C	F4	Fuse	gn	green
F3	Blade-type fuse holder 25A	GRs	8048 blower relay	ws	white
K3	Blower relay	GRr	Blower controller 8045	rt	red
K3.1	Supplementary relay	St 03	2-pin connector gn	sw	black
IPCU	Impulse width modulator	St 04	6-pin connector gn	br	brown
F1	Blade-type fuse holder 1A	KB	Air conditioning control 8080	ws	white
VWU	Time switch	GM	Blower motor 8050	ge	yellow
				X	splitting point

Legend

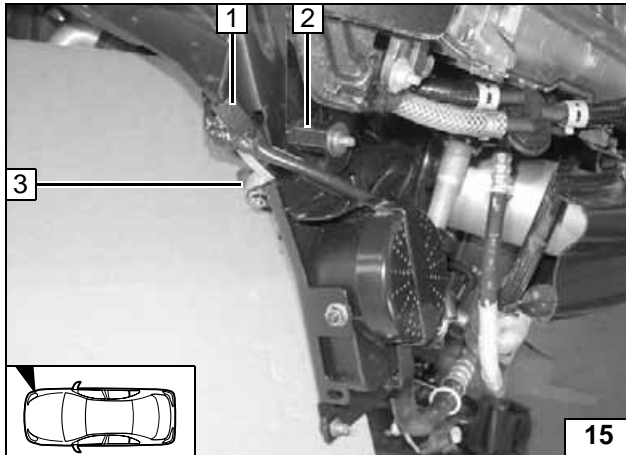

Preparing the Installation Location

Disassemble the alarm control. Fasten the 30mm spacer nut to original vehicle stay bolts. Fasten the alarm control to the spacer nut with the original vehicle bolt and body washer.

- (1) make edge protection, 50mm, from fuel hose
- (2) 30 mm spacer nut
- (3) M6x20 bolt, 10 mm spacer nut, flanged nut



Moving the alarm control

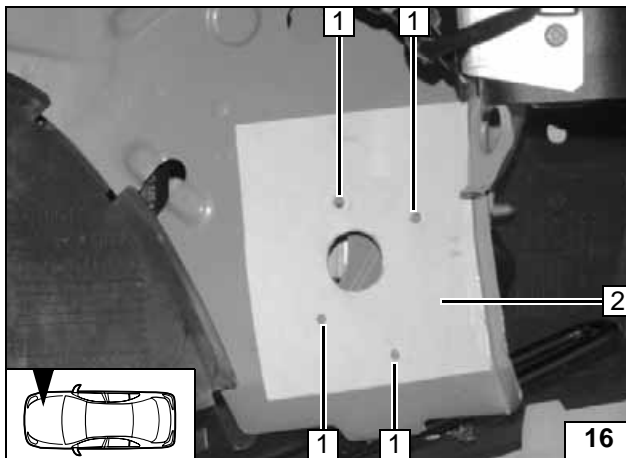

- (2) Template
- (1) copy the hole image [4x]

Preparing the installation location

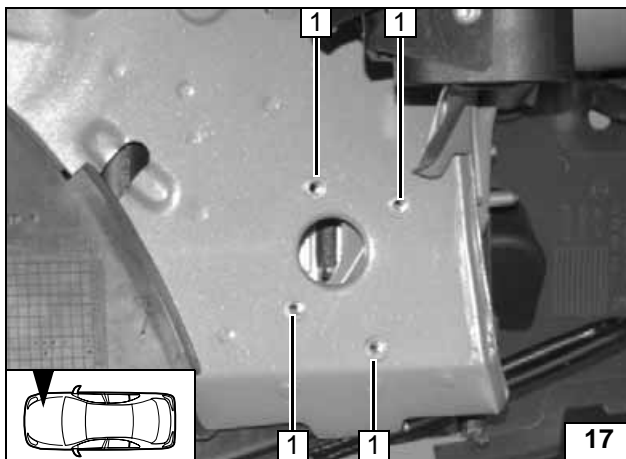

- (1) Ø 9.1mm bore hole, rivet nuts [4x]

Inserting rivet nuts

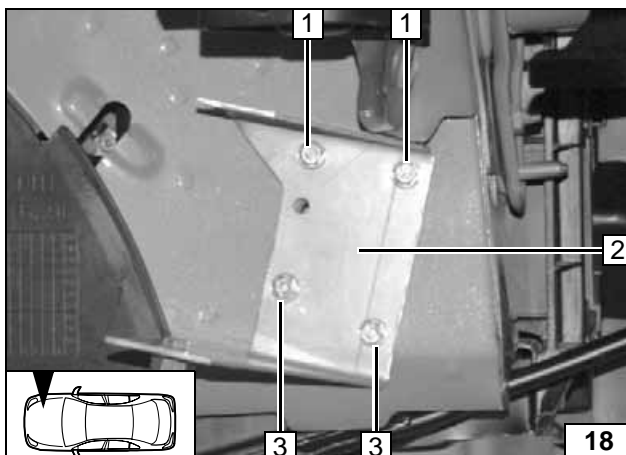

At position 1, insert one 10 mm spacer washer each between the bracket and the vehicle body and at position 3, insert an 8 mm spacer washer.

- (2) Bracket
- (1) M6x40 bolt, spring washer, 10mm spacer [2x each]
- (3) M6x40 bolt, spring washer, 8mm spacer [2x each]



Assembling the bracket

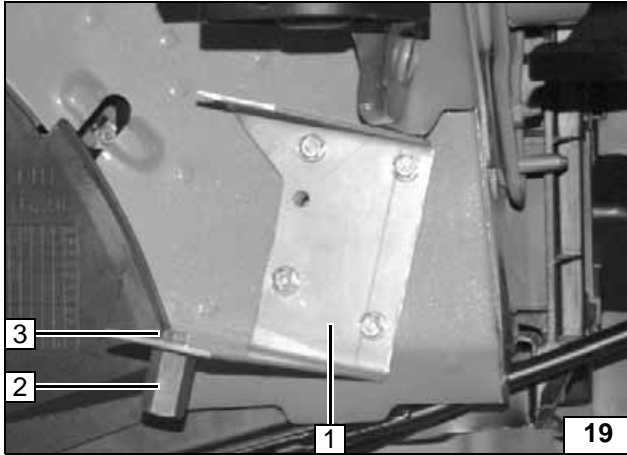
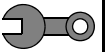

- (1) Bracket
- (2) Spacer nut M6x30
- (3) M6x16 bolt, spring washer

Assembling the spacer nut

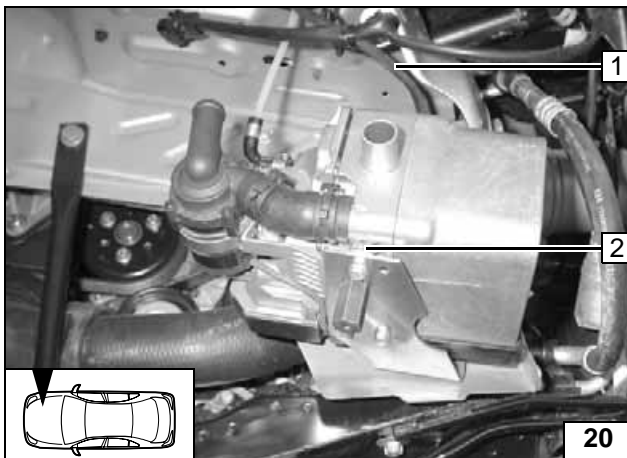

Installing the Heater Unit

Prior to assembly, put on the heater unit cable harness
 Insert two 5 mm spacer sleeves between the heater unit and the bracket in position 2.

- (1) Heater unit cable harness
- (2) 5 mm spacer sleeve



Assembling the heater unit

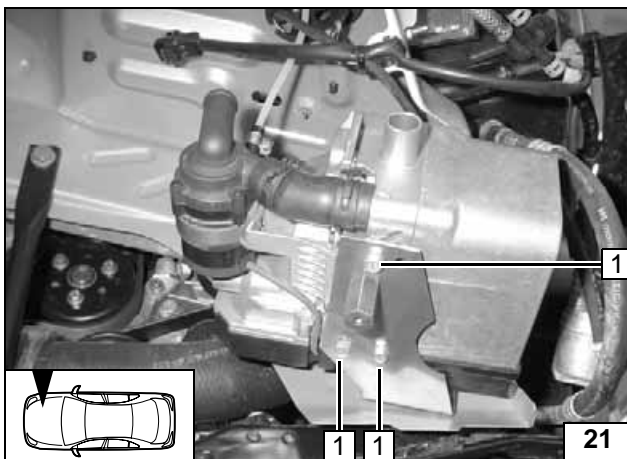

Ejet screw bolts tightening torque 10 Nm!
 Fasten the 4th ejet screw from the top (not visible here).

- (1) Ejet screws [4x]



Assembling the heater unit

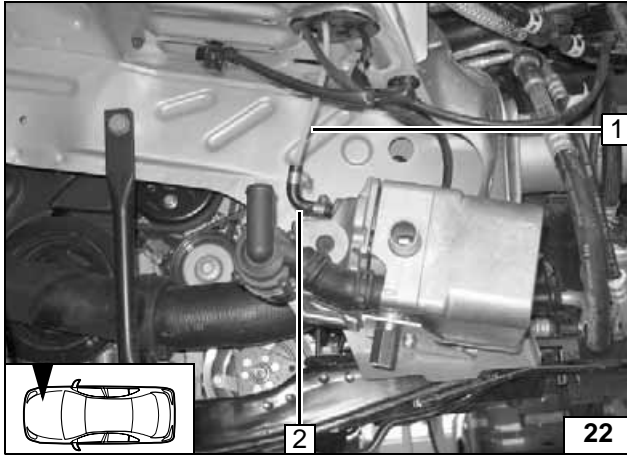
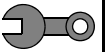

- (1) Mecanyl fuel pipe
- (2) 90° moulded hose, Ø 10 mm hose clamps [2x]

Connecting to the heater unit

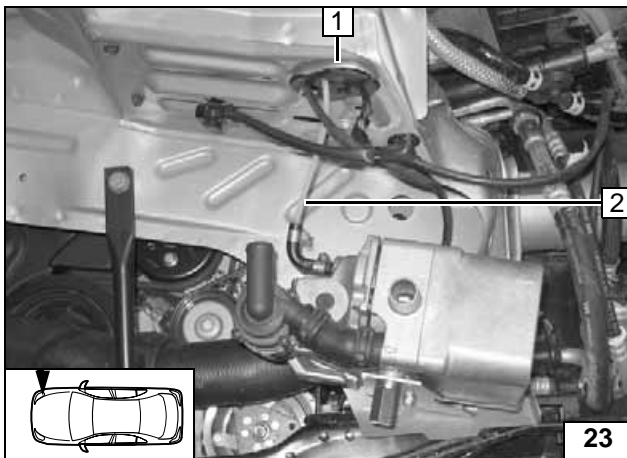

- (2) Mecanyl fuel pipe
- (1) original vehicle duct

Running the Mecanyl pipe

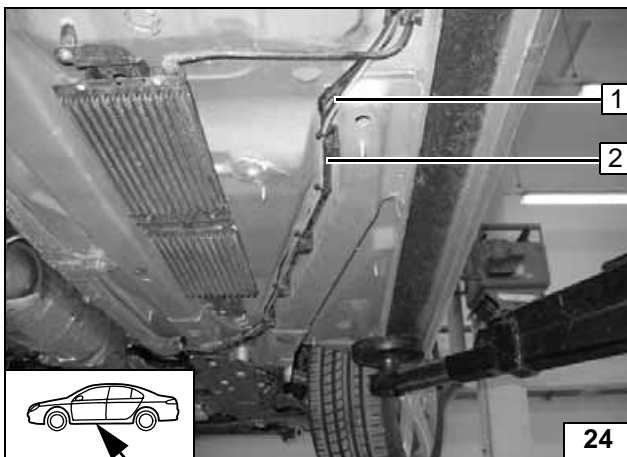

Running along the original vehicle fuel lines.



- (1) Mecanyl fuel pipe
- (2) Metering pump cable harness

Placement of lines on the underbody

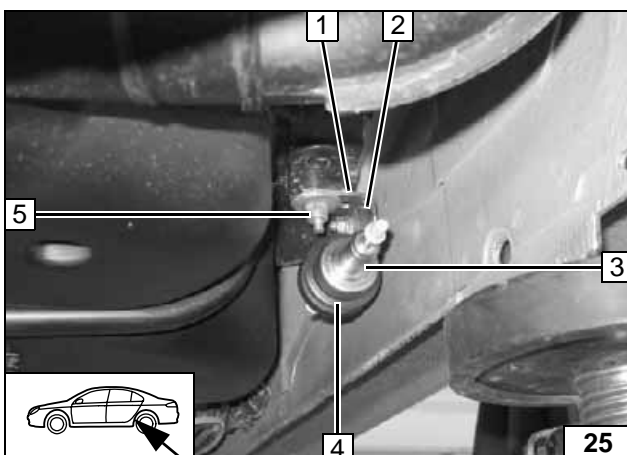

Note the installation position of the metering pump, see the Installation Instructions. Installation location is to the right next to the vehicle tank.



- (1) Angle bracket
- (5) original vehicle stay bolt, body washer, flanged nut
- (2) Silent block, flanged nut [2x] on the angle bracket
- (3) Metering pump
- (4) rubberised tube clamp

Installing the metering pump



Fuel Connection

CAUTION!

Open the vehicle's tank-cap lock, ventilate the tank and then re-close the tank lock.

Catch any fuel running off with an appropriate container.

Install fuel line and metering pump cable harness so that they are protected against impact from rocks!
Unless specified otherwise, always fasten using cable clips!
Fit the fuel line and cable harness with edge protectors around sharp edges.

WARNING!

The fuel line and cable harness to the metering pump should be installed based on Electrics diagram.

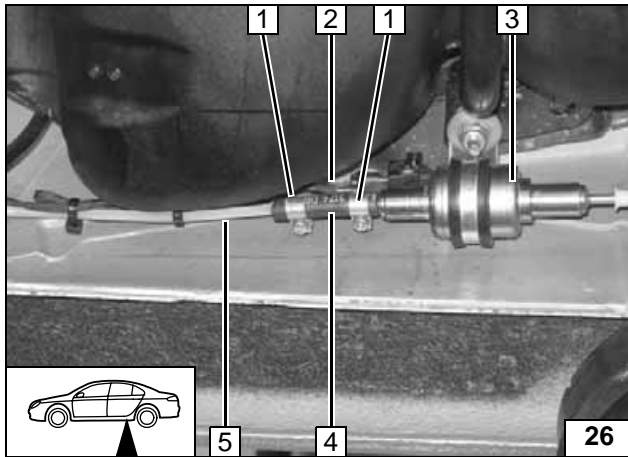

Fuel line from the heater unit on the pressure side of the metering pump [side with connector].

- (3) Metering pump
- (5) Mecanyl fuel pipe
- (4) Hose section
- (1) Hose clamps Ø 10 mm [2x]
- (2) Metering pump cable harness, wire seals, flat connector, connector housing



Connecting to the metering pump

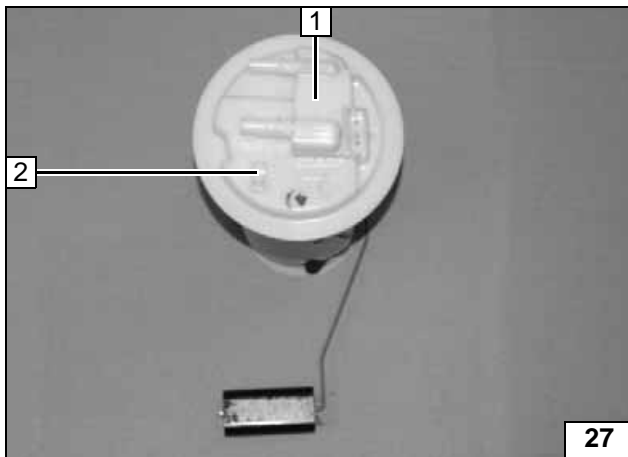

Remove the tank mounting according to the manufacturer's instructions and take it apart.

- (1) tank mounting
- (2) remove shackle.



Preparing the Tank Mounting

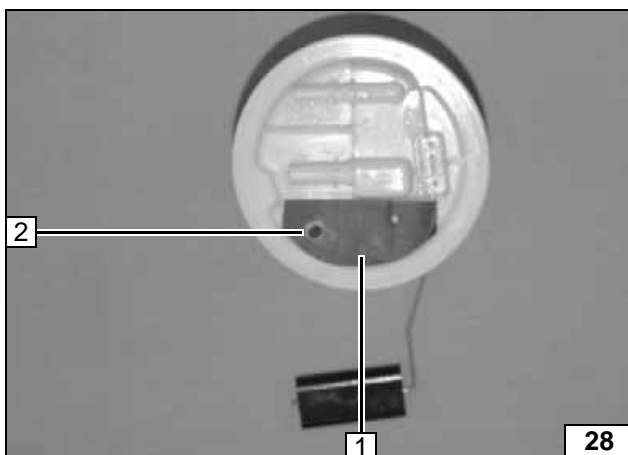

Remove the tank mounting according to the manufacturer's instructions and take it apart.

- (1) template
- (2) copy the hole image, Ø 6 mm bore hole



Preparing the Tank Mounting

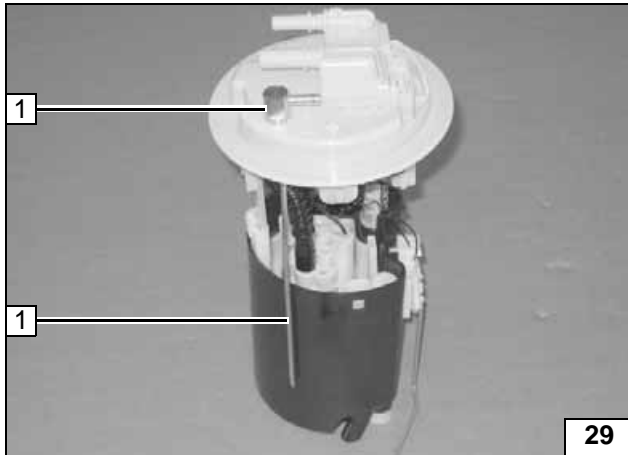

Shape, cut into sections, and insert the tank extracting device according to the template, see the Installation Instructions.

(1) Tank extracting device



Inserting tank extracting device

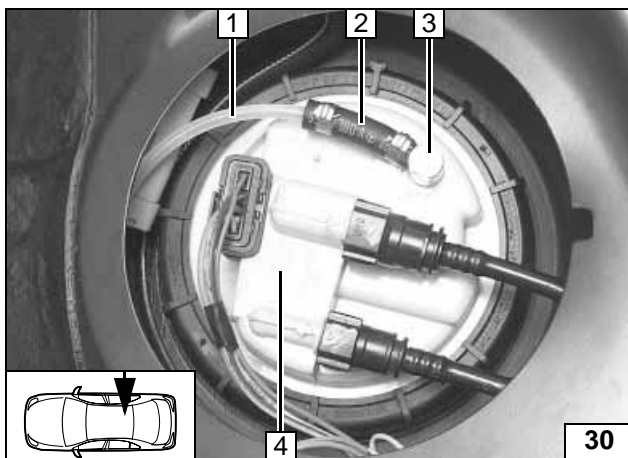

Install the tank mounting according to manufacturer's instructions.

(4) Tank mounting
 (3) Tank extracting device
 (1) remaining Mecanyl fuel line
 (2) Hose section, Ø 10 mm universal clip [2x]



Connecting and disconnecting the fuel line

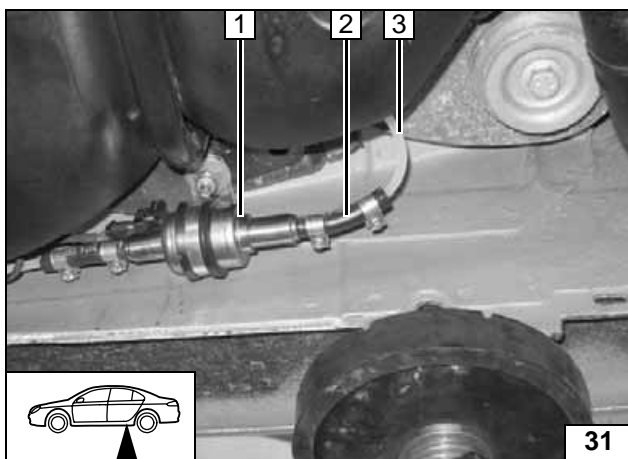

Fuel line from the tank extracting device on the intake side of the metering pump [side without connector].

Check the position of the components; adjust if necessary. Check that they have free clearance.

(1) Metering pump
 (3) Mecanyl fuel pipe
 (2) Hose section, Ø 10 mm hose clamps [2x]



Connecting to the metering pump



Water Connection

WARNING!

Tighten all hose clamps to 2.0 + 0.5 Nm.

Any cold water running off should be collected using an appropriate container!

Install hoses so that they are kink-free! Unless specified otherwise, always fasten using cable clips!

Position hose clamps and spring band clamps so that no other hose can be damaged!

The connection should be "inline" based on the following diagram:

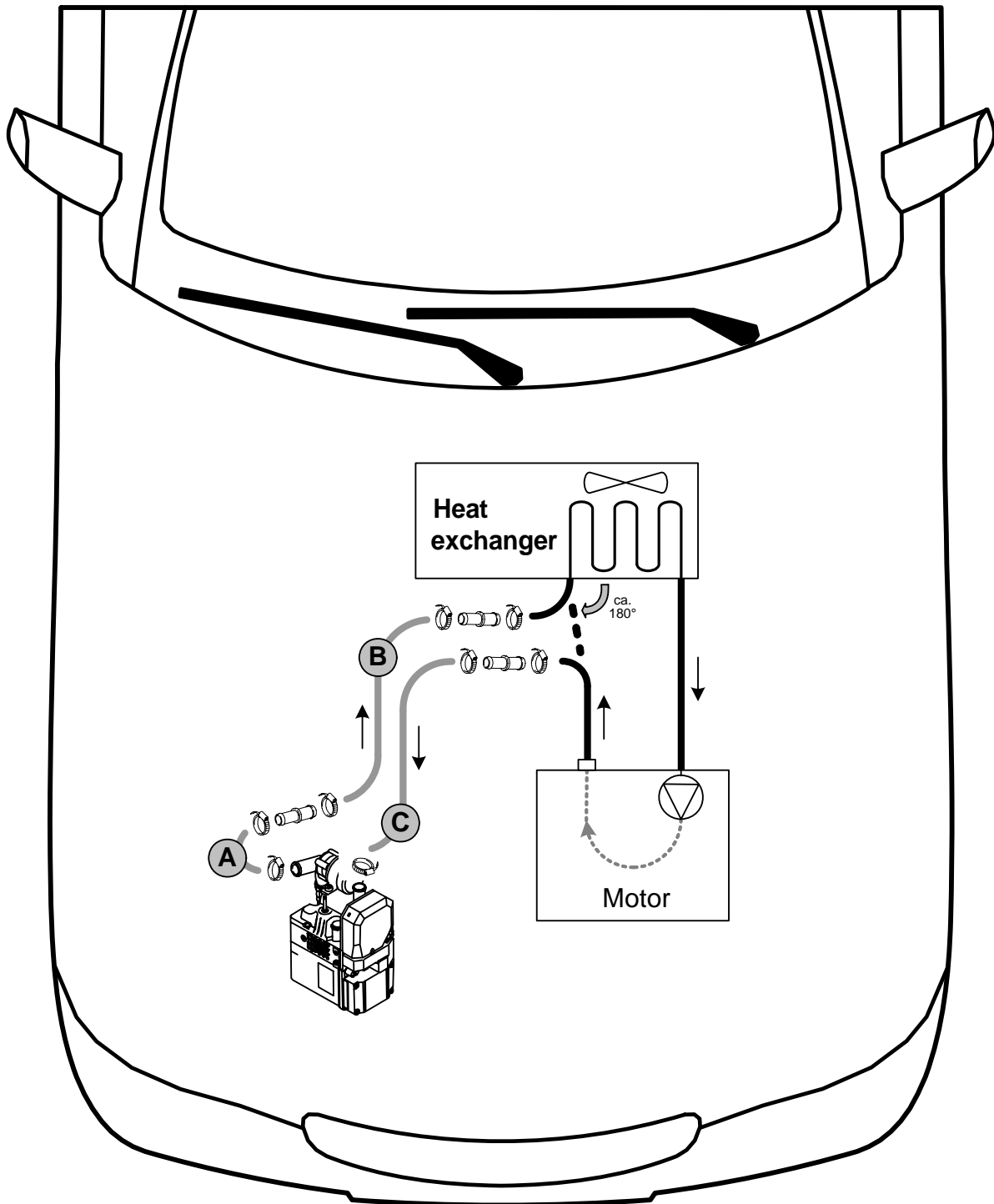

Water installation diagram

All hose clamps = Ø 20 - 27mm.
All connecting pipes are Ø 20x20.



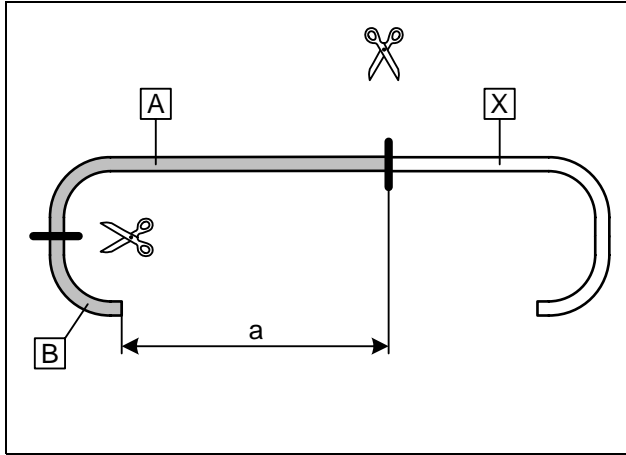

$a = 980 \text{ mm}$

Dispose of section **X**

Slide the braided protective hose onto hose **A**. Divide the shrink-fit hose in the middle, slide onto the ends of the braided hose and shrink.

Cutting water hoses into sections

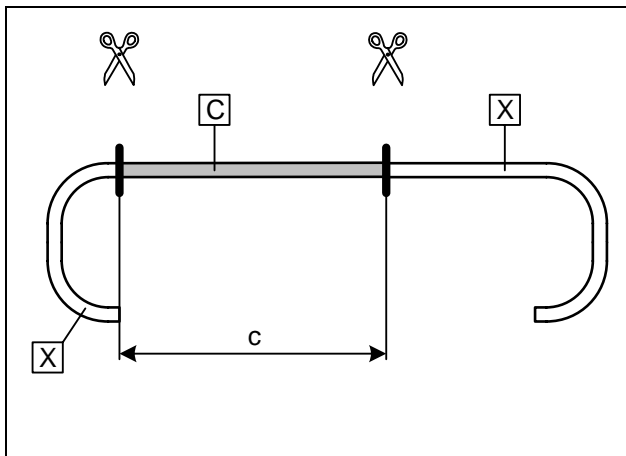

$c = 920 \text{ mm}$

Dispose of sections **X**

Slide the braided protective hose onto hose **C**. Divide the shrink-fit hose in the middle, slide onto the ends of the braided hose and shrink.

Cutting water hoses into sections

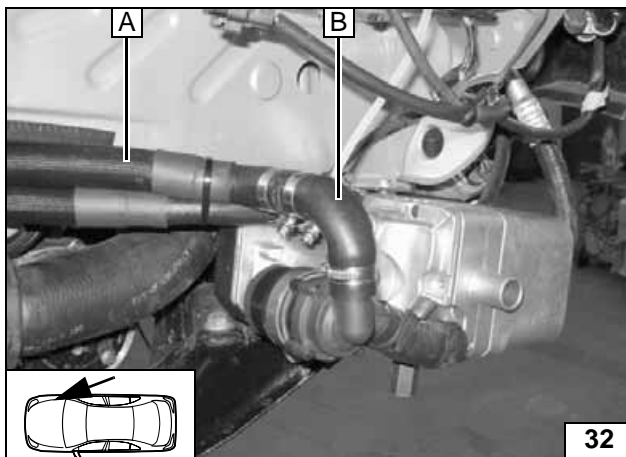

Connect the 90° bend from hose **A** and hose **B**.



Connection to the heater unit inlet

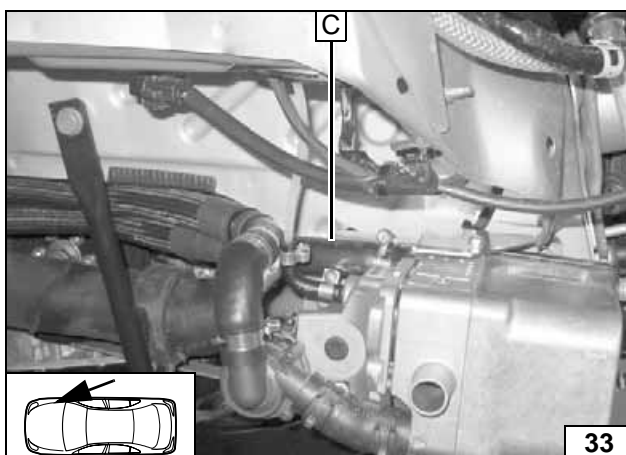

Connect the 90° bend from hose **A** and hose **B**. Assemble the hose **C** with 90° bend on the heater unit outlet.



Connection to the heater unit inlet

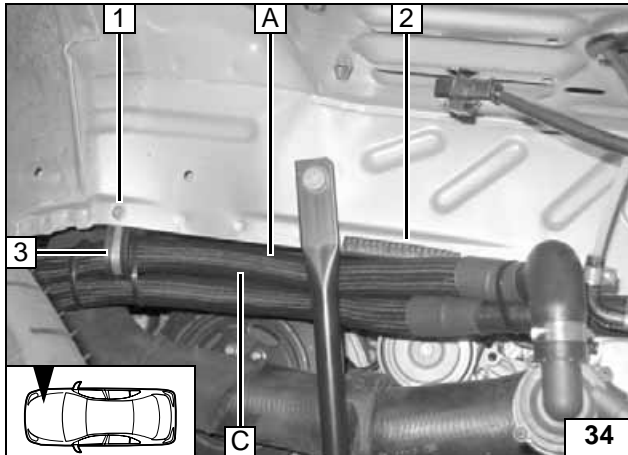

Hole at position 1 \varnothing 7 mm.
Cut 140 mm from enclosed edge protection.

- (1) M6x20 bolt, flanged nut
- (3) rubberised tube clamp
- (2) 140mm edge protection



Feed-through to engine compartment

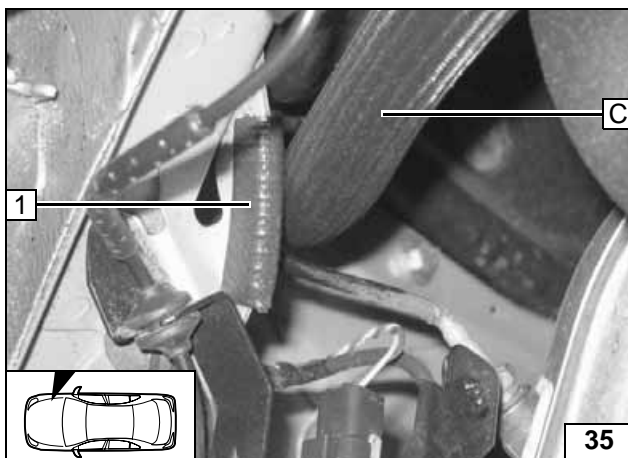

- (1) 60 mm remaining edge protection

Inserting edge protection

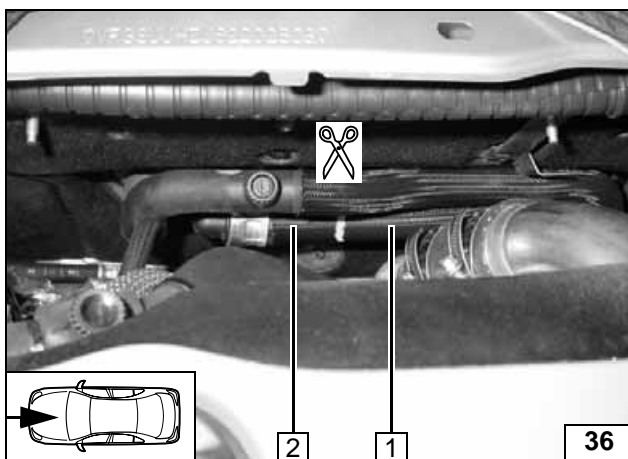

Clamp off the original vehicle hose from engine outlet to the heat exchanger inlet with the clamps and separate at the marking. Turn the heat exchanger inlet hose section about 180° the right.

- (1) Engine outlet hose section
- (2) Heat exchanger inlet hose section



Splitting point

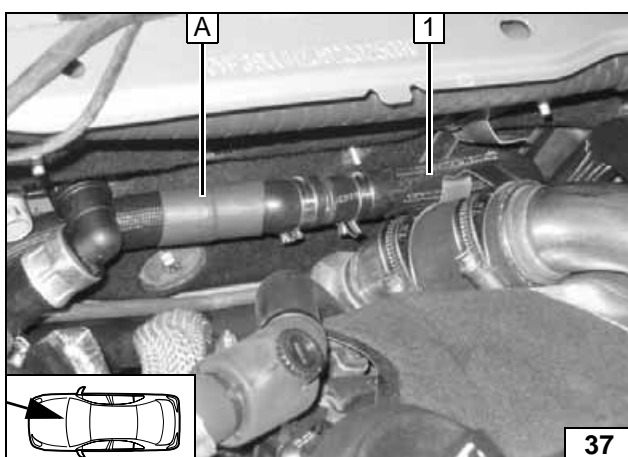

Before connecting, fill the water hoses with coolant water
Heat exchanger inlet water hose only removed for demonstration purposes!

- (1) Engine outlet hose section



Connecting to the engine outlet

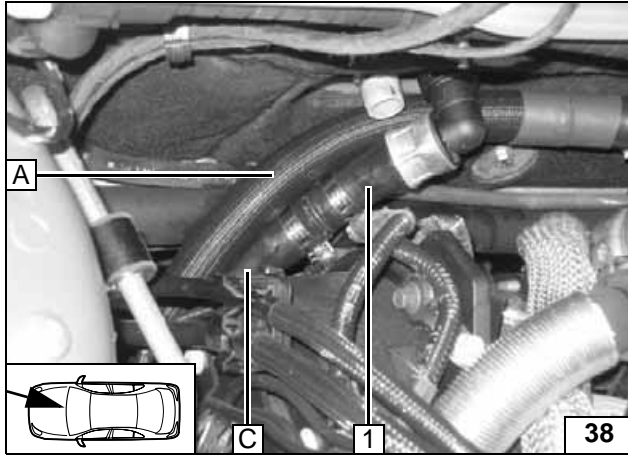

Before connecting, fill the water hoses with coolant water
Heat exchanger inlet water hose only removed for demonstration purposes!

(1) heat exchanger inlet hose section



Connection on the heat exchanger inlet

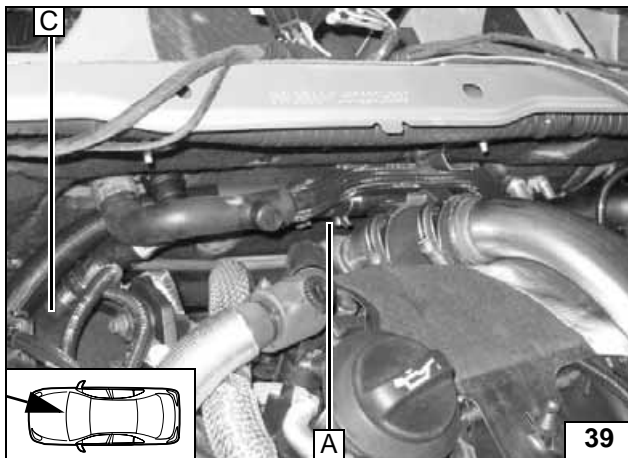

Aligning water hoses

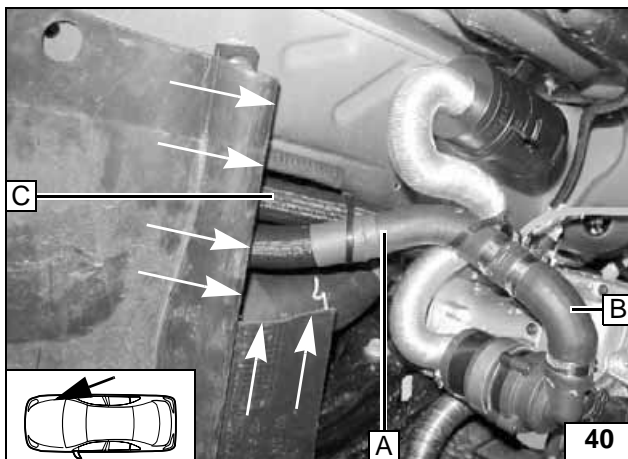

Cut out the wheel-house panel in the markings area.



Fitting wheel well lining

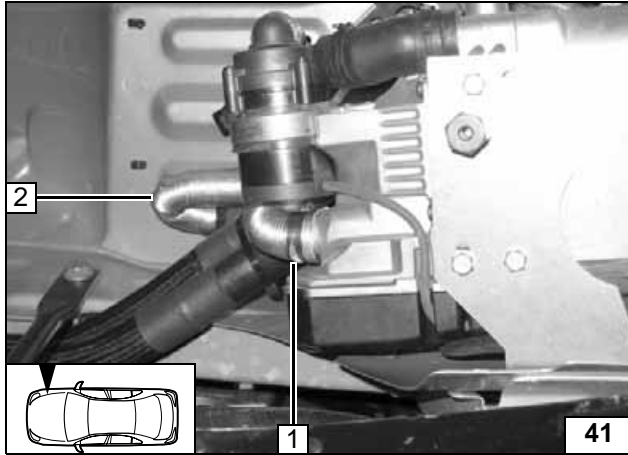

Combustion Air Connection

- (2) Combustion air intake pipe
- (1) Ø 27 mm hose clamp

Assembling
the
combustion
air line

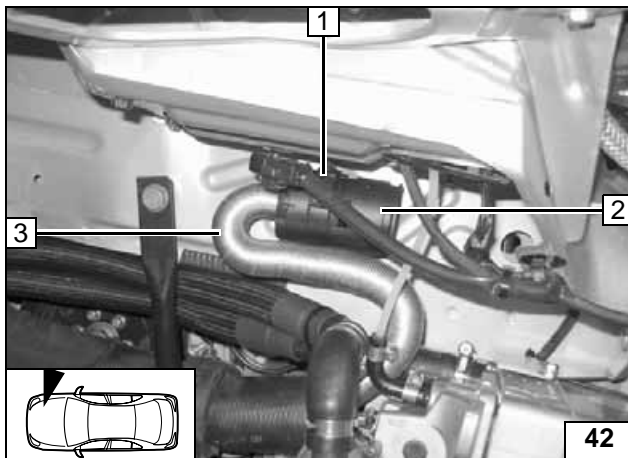

Note the installation position of the air intake silencer, see the Installation Instructions.

- (3) Combustion air pipe
- (1) Retaining clip in available bore hole
- (2) Combustion air intake silencer



Assembling
the silencer

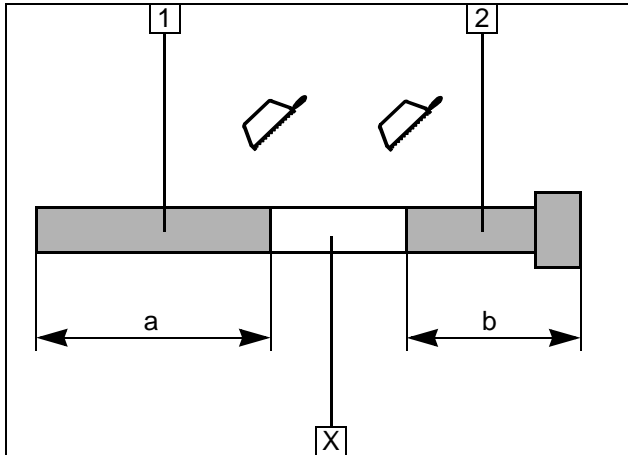
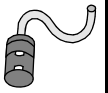

Exhaust connection

- (1) Exhaust pipe
a = 270 mm
- (2) Exhaust end section
b = 320 mm

Dispose of section X

Preparing the exhaust pipe

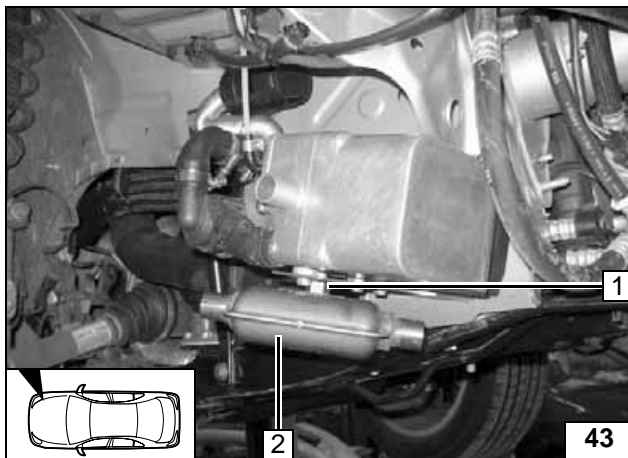

- (2) Silencer, M6x12 bolt, spring washer on spacer nut
- (1) Pre-assembled spacer nut

Assembling the silencer

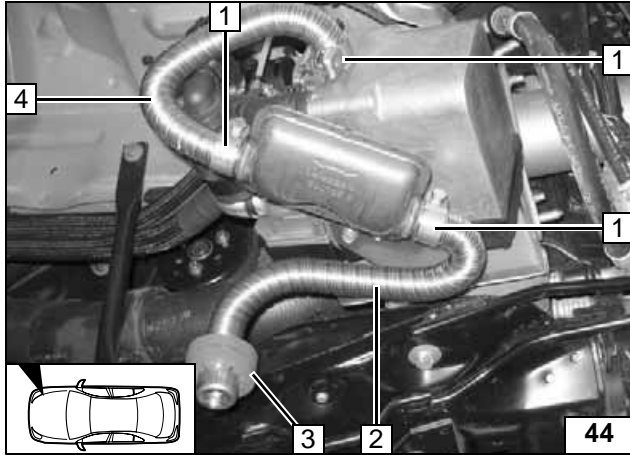

- (4) Exhaust pipe
- (2) Exhaust end section
- (1) Hose clamps [3x]
- (3) Position red (rt) rubber profile

Assembling the exhaust system

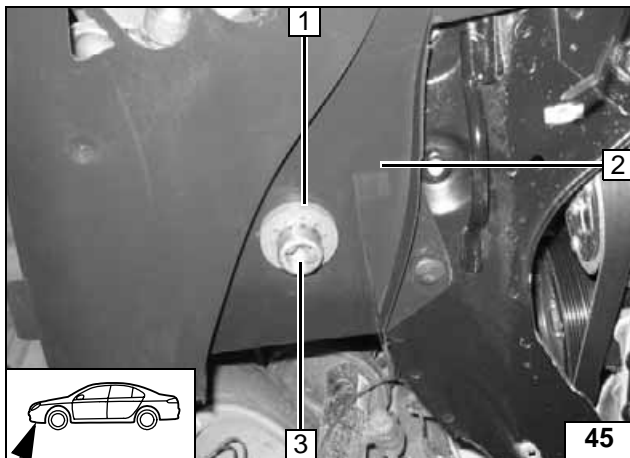

Hole \varnothing 42mm in underride protection at position **3**.
 First position the red (rt) rubber profile **1**, from below onto the exhaust end section **3**, then insert with groove in the underride protection **2**. Align the end cap from the exhaust end section **3** flush with the red (rt) rubber profile **1**.
 Check the position of the components; adjust if necessary. Check that they have free clearance.



Assembling the underride protection

- (2) Underride protection
- (3) Exhaust end section
- (1) Rubber profile

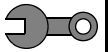

Final Work

WARNING!

Reassemble disassembled components in reverse order.

Check that all hose lines, hose, spring band clamps and universal clips, and all electrical connections are securely fastened.

Secure all loose cables using cable clips.

Spray heating unit components with anti-corrosion wax (Tectyl 100K, Order No. 111329).

- Connect battery
- Start engine, bleed water circuit according to the vehicle manufacturer's specifications, top up with cold water.
- Set the time switch.
- Set the vehicle heating with automatic air conditioning or without automatic air conditioning according to the "operating instructions for the end customer".
- On vehicles from 10/2005, use the vehicle diagnosis to set the air conditioning control to **auxiliary heating**.
- On vehicles from before 10/2005, the **air distribution flap is on the foot area**.
- Auxiliary heating is **not** possible when driving. Therefore, you must switch off the heater on the heater unit controller since otherwise the pre-set heating time will not expire.
- Check that the auxiliary heating operates properly, see operating instructions / installation instructions.
- Apply the "Switch off auxiliary heating before re-fuelling" sticker onto the left side of the B-pillar

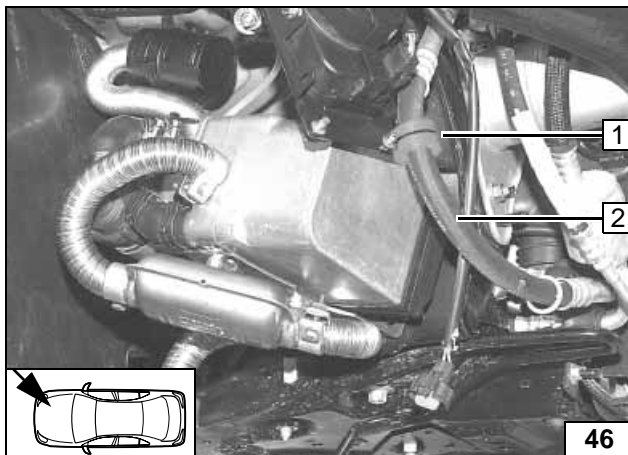

Cut open the red rubber profile, place this on the air conditioner line and fasten this in the groove with the cable clip.

- 1 Red (rt) rubber profile with groove
- 2 Air conditioner line

Inserting rubber profile

Webasto
Feel the drive

Webasto AG
Postfach 80 - 82132 Stockdorf - Hotline 0 18 05 / 93 22 78
Hotfax (0395) 55 92-353 - <http://www.webasto.de>

Operating instructions for the end customer

Please remove page and add to the vehicle operating instructions.

**On vehicles from before 10/2005, the air distribution flap is on the foot area.
Auxiliary heating is not possible when driving. Therefore, you must switch off the heater on the heater unit controller since otherwise the pre-set heating time will not expire.**

Before parking the vehicle, make the following settings:



- (2) air flow to "Defrost"
- (1) Left and right temperature to 29° C

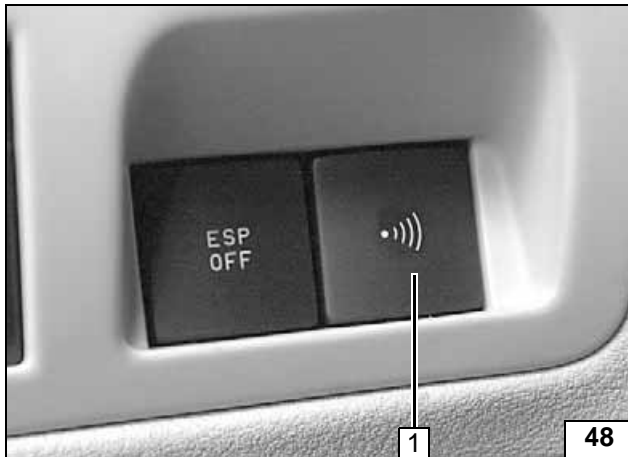

During the heating operation, the passenger compartment monitoring must be deactivated according to the manufacturer's instructions.

- (1) Switch off the passenger compartment monitoring



Settings



Switching off the passenger compartment monitoring

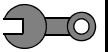

Bracket for Template

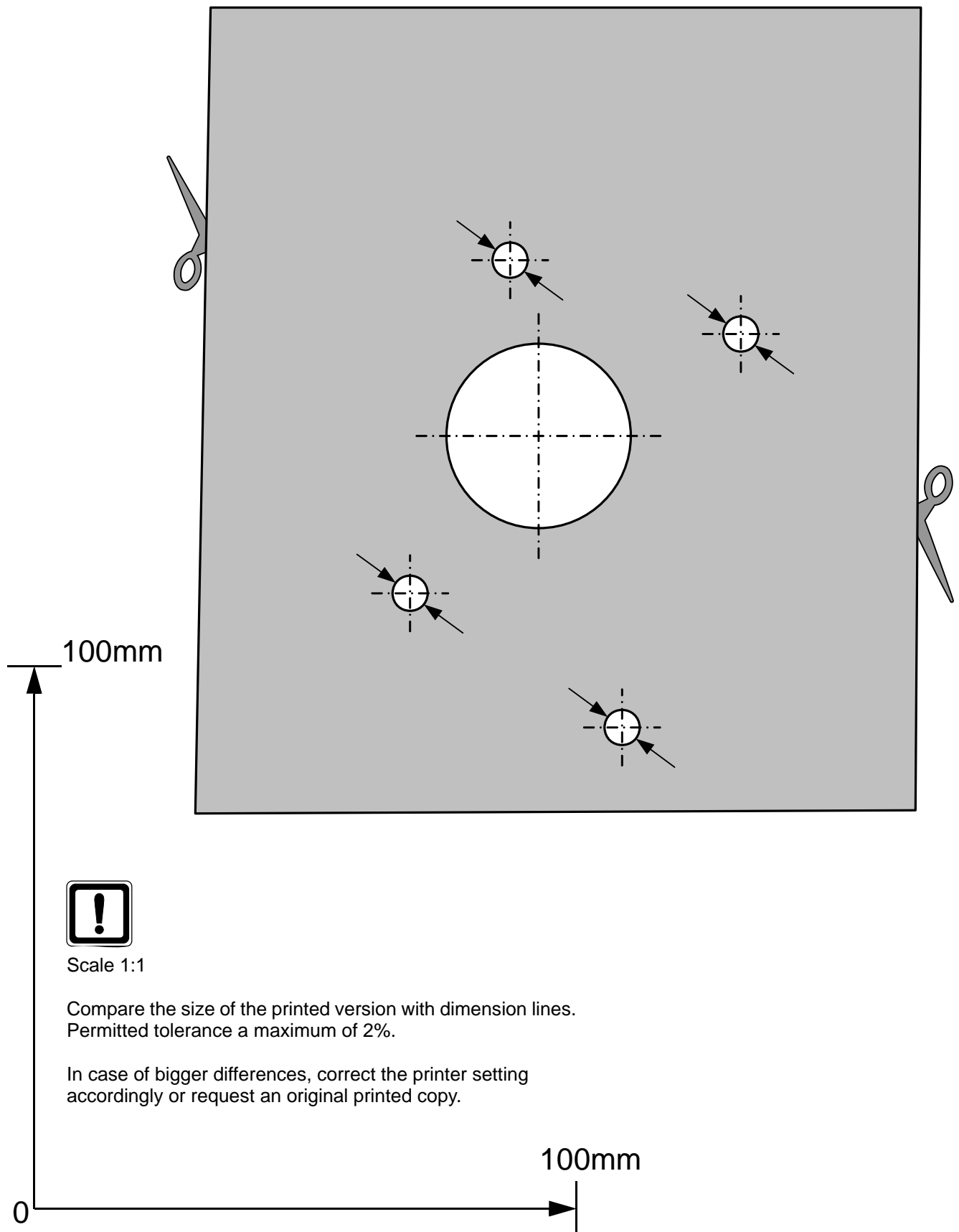

Scale 1:1

Compare the size of the printed version with dimension lines.
Permitted tolerance a maximum of 2%.

In case of bigger differences, correct the printer setting accordingly or request an original printed copy.

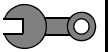

Tank mounting template

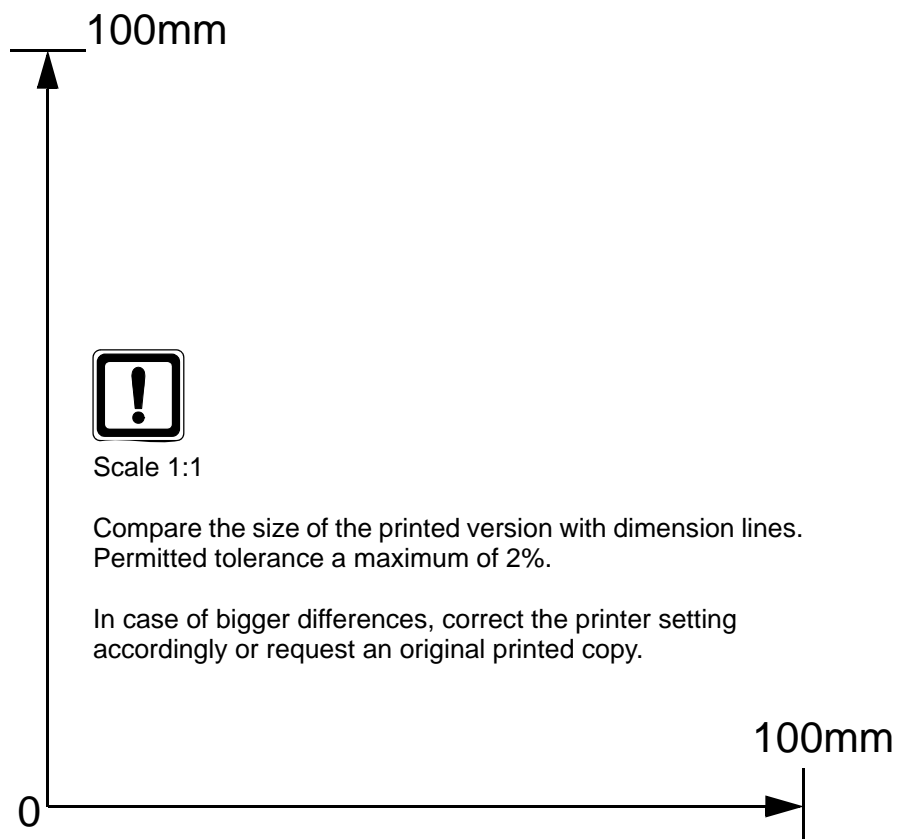
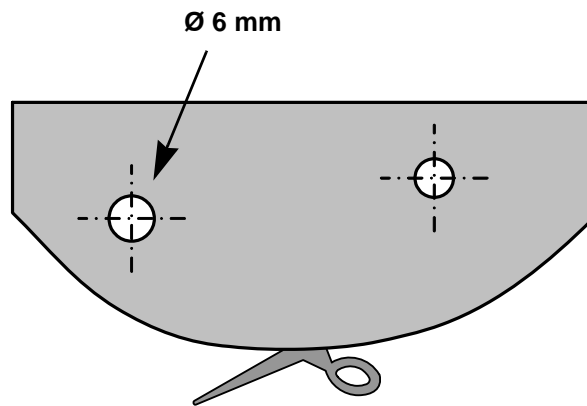

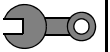

Tank extracting device template

Front view

Side view

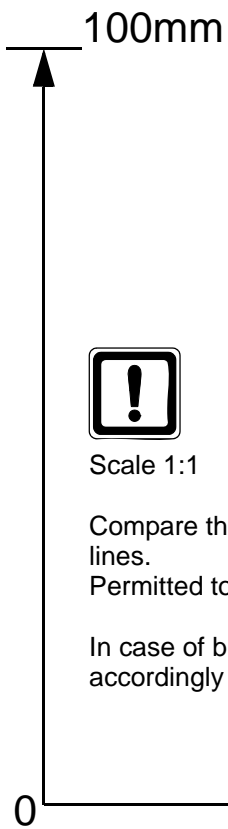
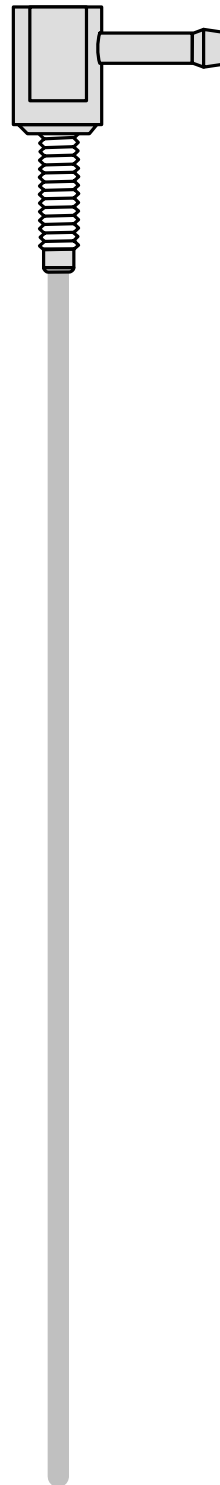

Scale 1:1

Compare the size of the printed version with dimension lines.
Permitted tolerance a maximum of 2%.

In case of bigger differences, correct the printer setting accordingly or request an original printed copy.