

Water Heater Upgrade to Parking Heater



**Thermo Top Z/C
Auxiliary Heater**

e1
00 0002

Upgrading instructions

VW T5

Diesel vehicle with Webasto auxiliary heater
from model year 2004
Left-hand drive vehicle
Climatic



WARNING!

Hazard warning:

The improper installation or repair of Webasto heating and cooling systems can cause fire or the leakage of deadly carbon monoxide, leading to serious injury or death.



To install and repair Webasto heating and cooling systems you need to have completed a special company training course and have the appropriate technical documentation, special tools and special equipment.

Only use genuine Webasto parts. See the Webasto air and water heaters accessories catalogue for this purpose.

NEVER attempt to install or repair Webasto heating or cooling systems if you have not successfully completed the company training and thereby acquired the required technical skills, or if you do not have access to the required technical documentation, tools and equipment needed to carry out correct installation and repairs.

ALWAYS follow all Webasto installation and repair instructions and observe all warnings.

Webasto does not accept any liability for defects and damage that are attributable to installation by untrained staff.

Table of Contents

Validity	2
Heater / Installation Kit	2
Foreword	3
General Instructions	3
Special Tools	3
Preliminary Work	3
Explanatory Notes on Document	4
Electrical System	5
Fan Controller	6
Digital Timer	9
Remote Option (Telestart)	9
Final Work	10
Operating Instructions for End Customer	11

Validity

Manufacturer	Model	Type	EG BE No. / ABE
VW	Transporter	T5	e1 * 2001 / 116 * 0218 * ...
VW	Transporter	T5	e1 * 2001 / 116 * 0220 * ...

Vehicle and engine types, equipment variants and national specifications not listed in these upgrading instructions have not been tested. However, installation according to these upgrading instructions may be possible.

Heater / Installation Kit

Quantity	Description	Order No.:
1	Upgrade kit for VW T5 2004 Diesel Climatic	9012103D
1	Heater control (in case of digital timer use order No.: 1301122C)	See price list

Foreword

These upgrading instructions apply to the VW T5 Diesel vehicle with Webasto auxiliary heater vehicles - for validity, see page 2 - from model year 2004 and later, assuming technical modifications to the vehicle do not affect installation, any liability claims excluded. Depending on the vehicle version and equipment, modifications may be necessary during installation with respect to these "upgrading instructions".

However, where this is the case the stipulations in the "upgrading instructions" and "operating and maintenance instructions" for the *Thermo Top C* should be observed.

The manufacturer's instructions should be observed when dismantling work on the vehicle is not shown or described. The corresponding rules of technology and any information from the vehicle manufacturer should be observed during the installation work.

The "parking ventilation" function is not available.



General Instructions

Installation should be carried out according to the general, standard rules of technology. Unless specified otherwise, fasten hoses, lines and wiring harnesses to original vehicle lines and wiring harnesses using cable ties.

Sharp edges should be fitted with rub protection (split-open fuel hose).

Spray unfinished body areas, e.g. drilled holes, with anti-corrosion wax (Tectyl 100K, Order No. 111329).

Special Tools

- Torque wrench for 2.0 - 10 Nm
- Hose clamping pliers
- Unlocking tool for radio navigation device
- Unlocking tool for the radio
- Hook

Preliminary Work

WARNING!

- If present, remove the battery cover.
- If present, remove the engine design cover.
- Disconnect the battery!
- Remove the partition wall trim behind the battery.
- Remove the lower instrument panel trim on the driver's side.
- Clip out the speaker cover on the top left of the instrument panel (only in case of Telestart).
- Remove the lateral instrument panel trim on the driver's side.
- Remove the entry trim on the driver's side.
- Uncover the heater at the underbody level and remove the connector.
- Remove the trim piece for the radio / A/C control panel.
- Remove the A/C control panel in accordance with the manufacturer's instructions.



Remove page 11 "Operating Instructions for End Customer" and add to the vehicle operating instructions.

Explanatory Notes on Document

You will find an identification mark on the outside top right corner of the page in question to provide you with a quick overview of the individual working steps.

Mechanical system

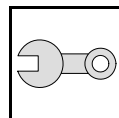

Electrical system

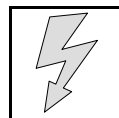

Coolant circuit

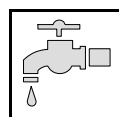

Fuel

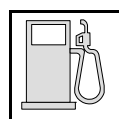

Exhaust gas

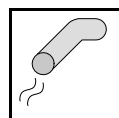

Combustion air

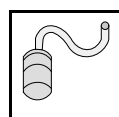

Software

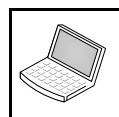

Special features are highlighted using the following symbols:



Specific risk of injury or fatal accidents.



Specific risk of damage to components.



Specific risk of fire or explosion.



Reference to general installation instructions of Webasto components or to the manufacturer's vehicle-specific documents.



Reference to a special technical feature.

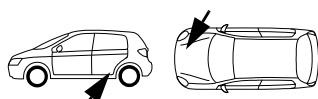

The arrow in the vehicle icon indicates the position on the vehicle and the viewing angle.

All dimensions are in mm!

Tightening torque of hose clamps = 2.0 + 0.5 Nm!

Tightening torque of Ejet screws, Ejet studs = 10 Nm!



Electrical System

Positive wire

- 1 Positive wire on positive battery terminal

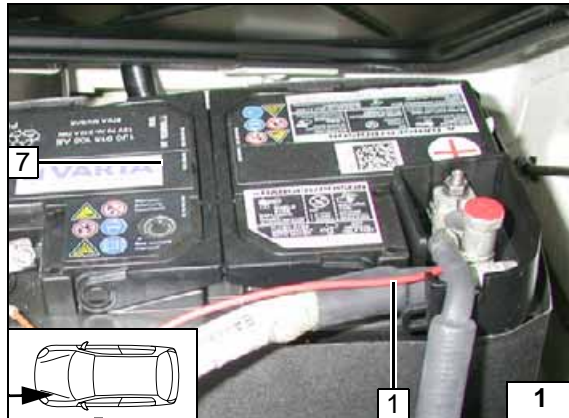

Earth wires

- 1 Original vehicle bolt
- 2 Earth wires

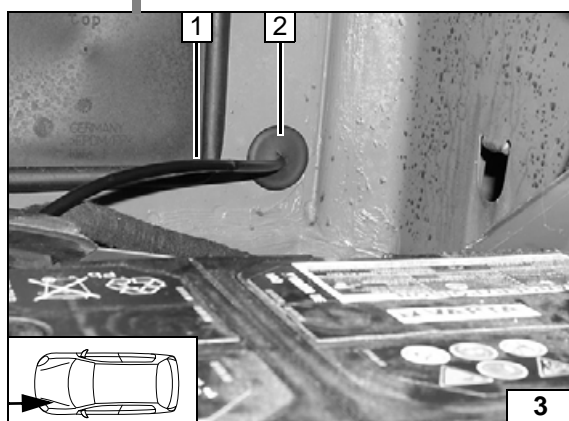
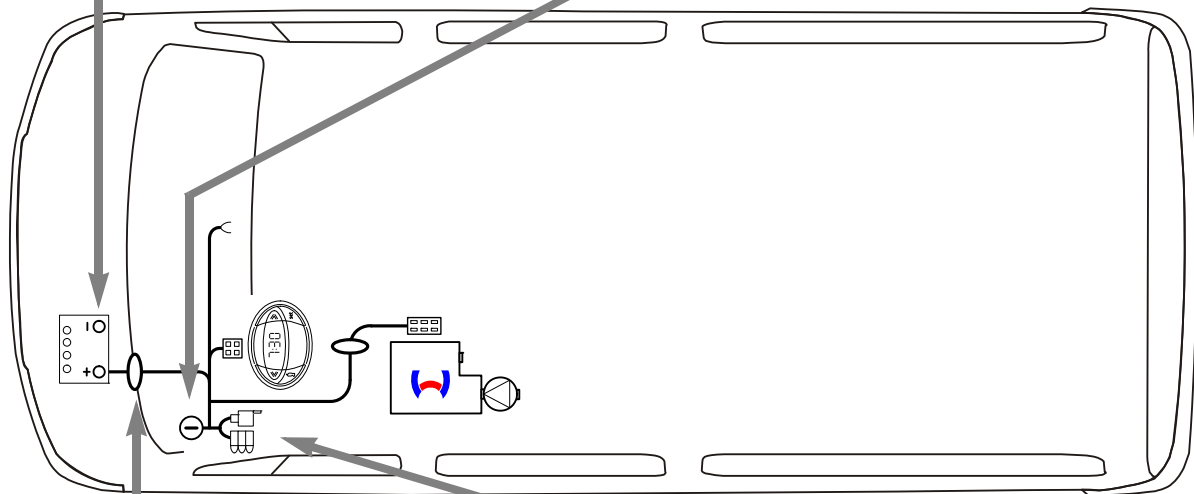
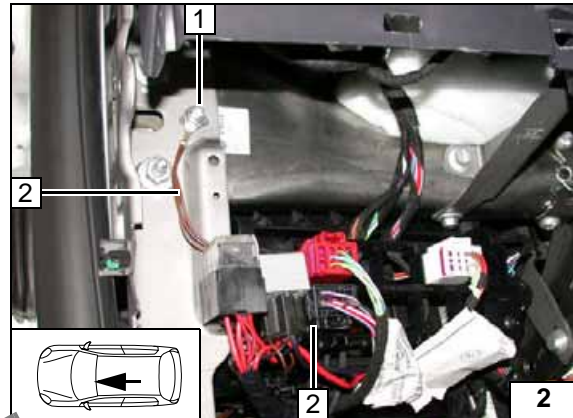

Wiring harness pass through

Route positive wire 1 from the passenger compartment through the protective rubber plug 2 into the engine compartment.

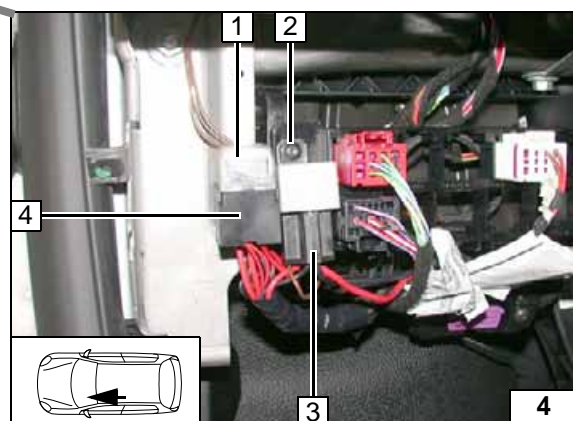

Fuse holder, K3 relay

Drill out original vehicle hole in position 1 to 4.5mm dia.

- 2 Original vehicle bolt
- 3 K3 relay
- 4 Fuse holder retaining plate, M4x12 bolt, nut



Wiring harness routing diagram



Fan Controller

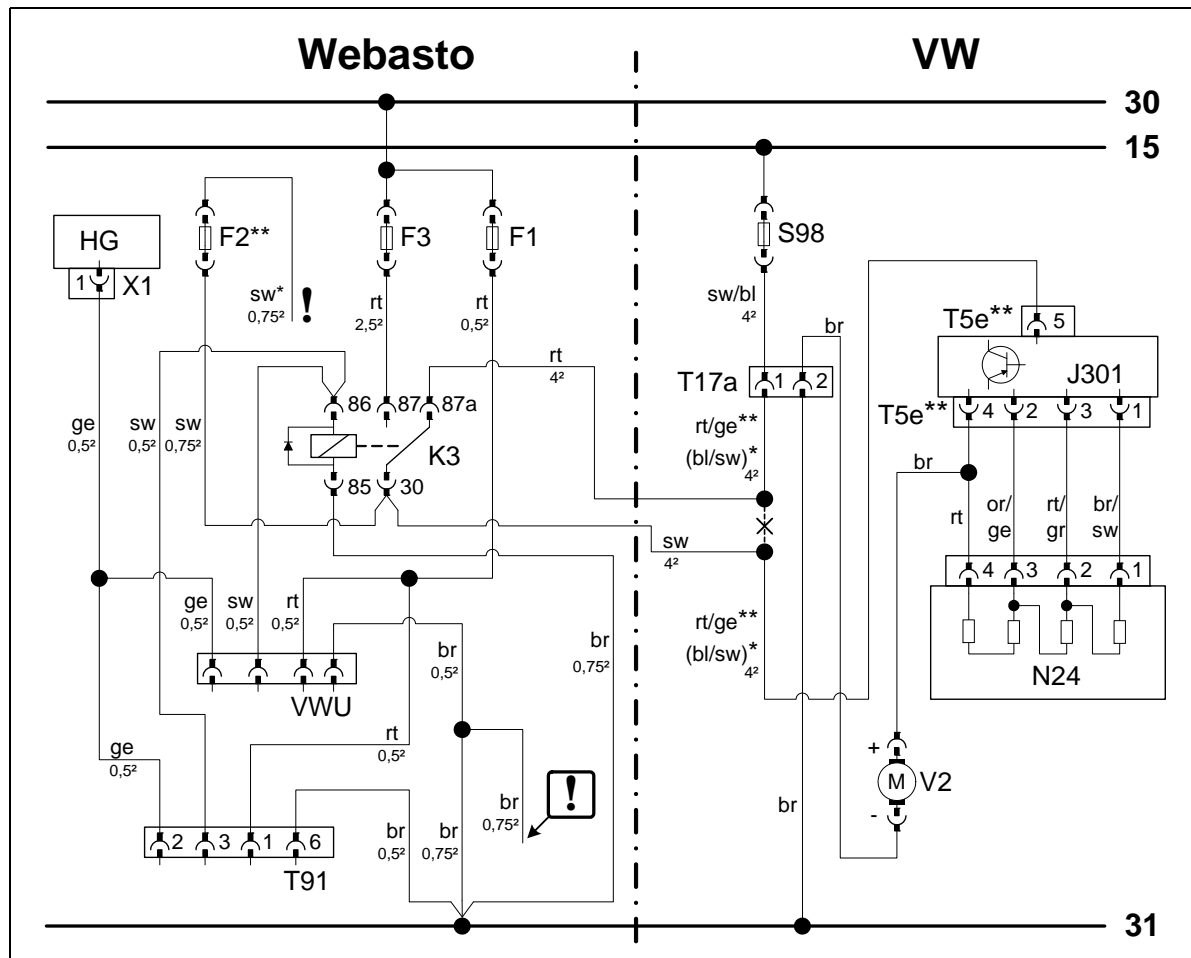

Climatic wiring diagram

Webasto components		Vehicle components		Colours and symbols	
HG	Heater TT-C/E	V2	Fan motor	rt	red
X1	6-pin heater connector	J301	A/C control unit	ge	yellow
F1	1A fuse	T5e	5-pin connector J301	sw	black
F2**	Remove 5A fuse in case of MY 2010	N24	Resistor group	bl	blue
F3	25 A fuse	S98	40A fuse	br	brown
K3	Fan relay	T17a	17-pin connector	or	orange
VWU	4-pin connector of digital timer			gr	grey
T91	6-pin connector of Telestart receiver			*	from MY 2004
				**	from MY 2010
				!	Black (sw) wire on circulating pump connector for MY 2004
				!	Insulate wire end and tie back
				X	Cutting point
				Wiring colours may vary.	

Legend

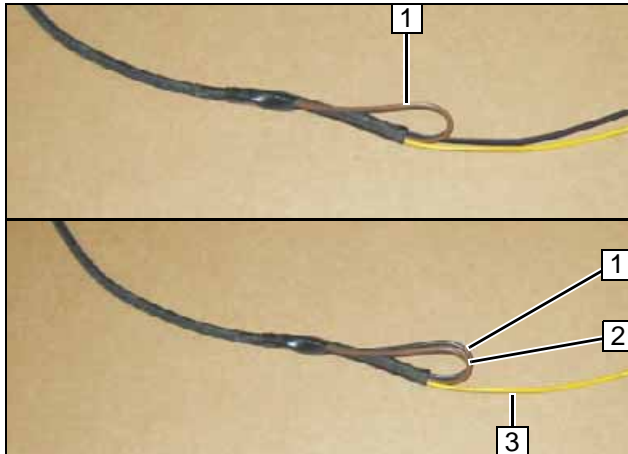

from Model Year 2004

- Insulate and tie back brown (br) wire 1.
- 2 Black (sw) wire to connect the circulating pump
- 3 Yellow (ge) wire to connect the heater

from Model Year 2010

- Remove 5A fuse F2. Insulate and tie back black (sw) wire 1 and brown (br) wire 2.
- 3 Yellow (ge) wire to connect the heater

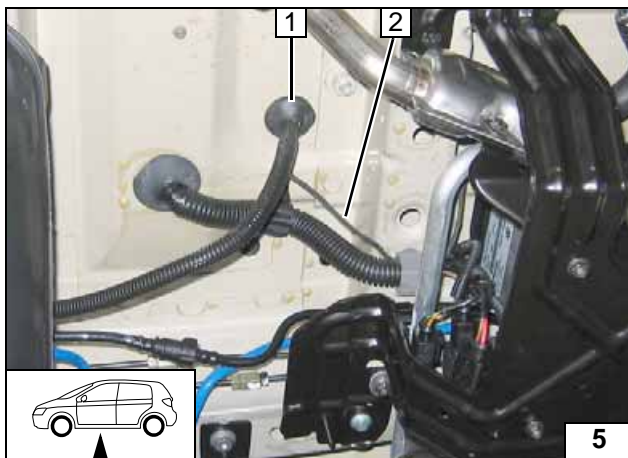

2004

Route yellow (ge) and black (sw) wire 2 for heater and circulating pump control through protective rubber plug 1 to the heater.

2010

Route yellow (ge) wire 2 for heater control through protective rubber plug 1 to the heater.

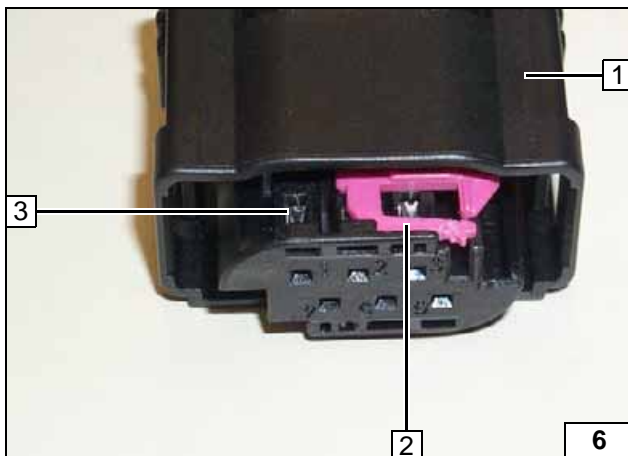

All vehicles

Disconnect 6-pin connector X14 1 from the heater. Unlock secondary locking device 2 of 6-pin connector (move to the right).

- 3 Socket Pin1

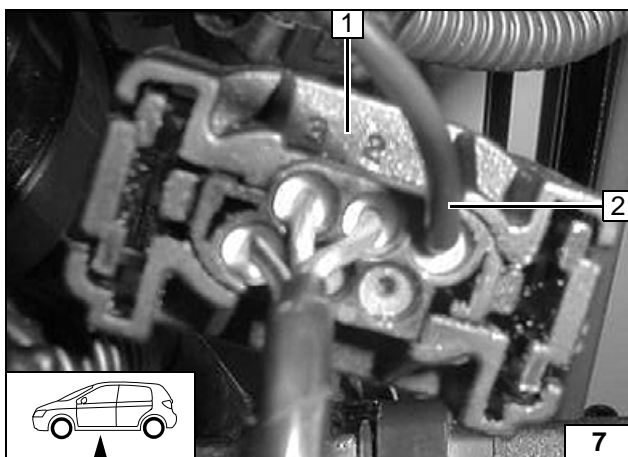

Engage yellow (ge) wire 2 into pin 1 socket of connector X14 1. Close the secondary locking device again. Connect connector X14 1 to the heater.



Preparing wiring harness



Routing wires



Connecting heater connector



Connecting heater connector

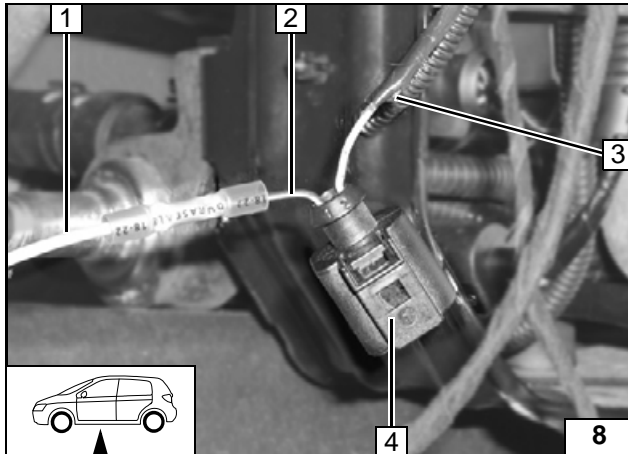

from Model Year 2004

Cut blue/black (bl/sw) wire at approx. 70mm from circulating pump connector 4. Insulate and tie back blue/black (bl/sw) wire 3 from original vehicle wiring harness!

- 1 Black (sw) wire of K3/30
- 2 Blue/black (bl/sw) wire of circulating pump connector



**Connect-
ing circu-
lating
pump**

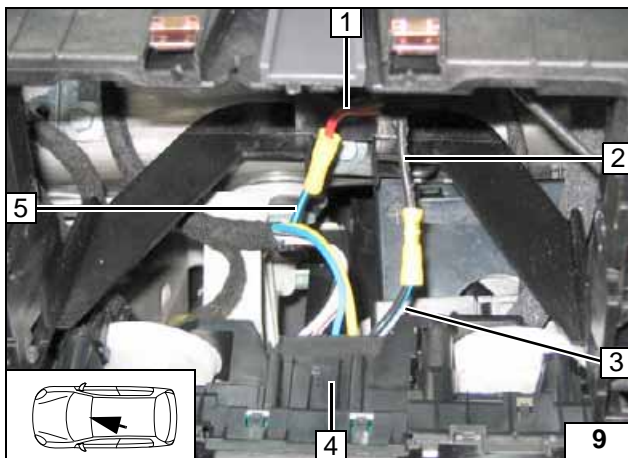

Connection to 5-pin connector 4 from A/C control panel.
Produce connections as shown in wiring diagram.

- 1 Red (rt) wire of K3/87a
- 2 Black (sw) wire of K3/30
- 3 Blue/black (bl/sw) wire of 5-pin connector, pin 5
- 5 Blue/black (bl/sw) wire of fuse



**Connect-
ing A/C
control
panel**

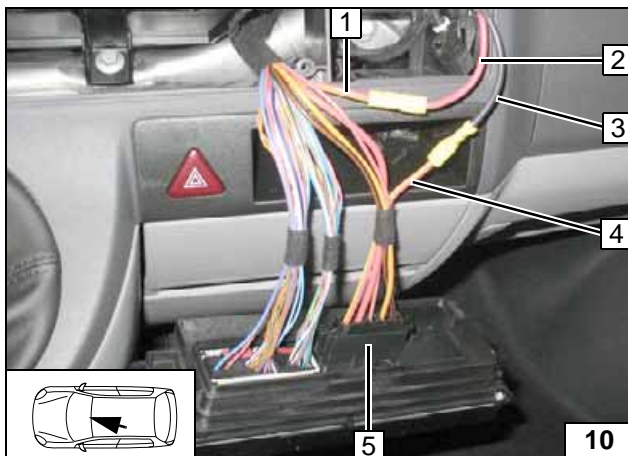

from Model Year 2010

Connection of the 5-pin connector T5e 5 of the A/C control panel.
Produce connections as shown in wiring diagram.

- 1 Red/yellow (rt/ge) wire of fuse S98
- 2 Red (rt) wire of K3/87a
- 3 Black (sw) wire of K3/30
- 4 Red/yellow (rt/ge) wire of 5-pin connector T5e, pin 5



**Connect-
ing A/C
control
panel**

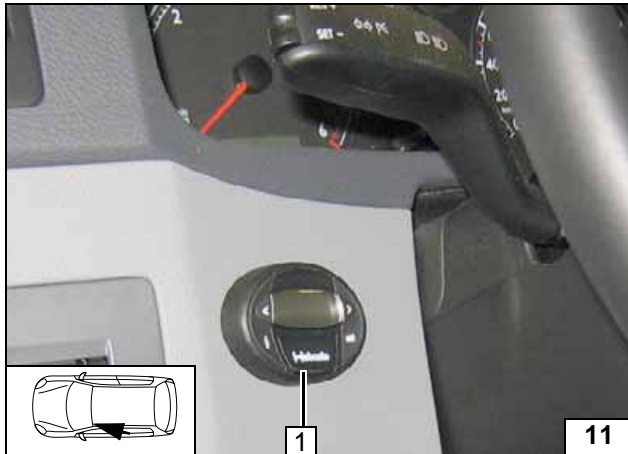

Digital Timer

- 1 Digital timer



Mounting digital timer

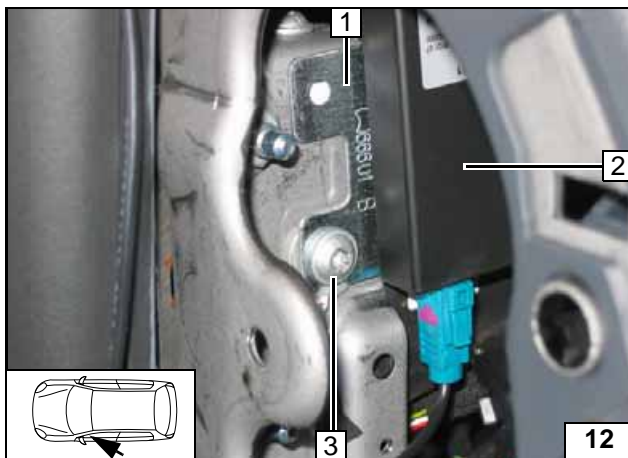

Remote Option (Telestart)

The Y-adapter wiring harness from the radio remote control installation kit is not required. Please dispose of it in a proper manner.

Drill out bracket 1 to 6.5 mm dia. at position 3.

- 2 Receiver
- 3 Original vehicle bolt, earth wire, large diameter washer



Mounting receiver

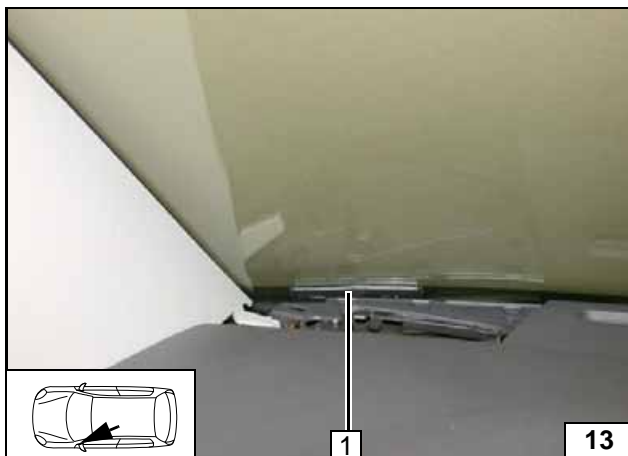

- 1 Antenna

Mounting antenna



Final Work

WARNING!

Install removed parts in reverse order.
Check all electrical connections for firm seating.
Secure all loose cables using cable ties.

- Connect the battery.
- Set the digital timer, teach the Telestart
- Make settings on A/C control panel according to the "Operating Instructions for End Customer".
- Check the proper functioning of the parking heater, see the operating instructions/installation instructions.
- Place the "Switch off parking heater before refuelling" caution label near the filler neck.



Webasto Thermo & Comfort SE
Postfach 1410
82199 Gilching
Germany
Internet: www.webasto.com
Technical Extranet:
<http://dealers.webasto.com>

Operating Instructions for End Customer



Please remove page and add to the vehicle operating instructions.

Note:

We recommend matching the heating time to the driving time.

Heating time = driving time

Example:

For a driving time of approx. 20 min. (in one direction), we recommend not exceeding a switch-on time of 20 min.



Passenger compartment monitoring, if installed, must be deactivated in addition to vehicle settings for the heating operation.

For instructions on deactivation, please refer to the operating instructions of the vehicle.

Before parking the vehicle, make the following settings:



- 1 Air outlet to windscreen
- 2 Set temperature to "max."
- 3 Set fan to level "1", or max. "2"

Heater control from MY 2004



- 1 Air outlet to windscreen
- 2 Set temperature to "max."
- 3 Set fan to level "1", or max. "2"

Climatic from MY 2010