

# Water Heater



**Thermo Top E Parking Heater**

  
00 0003

**Thermo Top C Parking Heater**

  
00 0002

## Installation documentation

### VW T5

Diesel

from Model Year 2004

For left-hand drive vehicles only



#### **WARNING!**

Hazard warning:

Incorrect installation or repair of Webasto heating systems may cause a fire or result in the emission of carbon monoxide, which can be fatal. Serious or fatal injuries can be caused as a result.



Specialist company training, technical documentation, specialised tools and equipment are required to install and repair Webasto heating and cooling systems. Only original Webasto parts must be used. For this, also see the catalog of air and water heater accessories from Webasto.

**NEVER attempt to install or repair Webasto heating or cooling systems if you have not successfully completed the company training and thereby acquired the required technical skills, or if you do not have access to the required technical documentation, tools and equipment needed to carry out correct installation and repairs.**

ALWAYS follow all Webasto installation and repair instructions and observe all warnings.

**The initial startup is to be executed with the Webasto Thermo Test Diagnosis.**

Webasto does not accept any liability for defects and damage that are attributable to installation by untrained staff.

**Table of Contents**

Validity	2	Preparing Installation Location	13
Heater/Installation Kit	3	Preparing Heater	13
Foreword	3	Installing Heater	18
General Instructions	3	Coolant circuit	18
Special Tools	3	Fuel	20
Explanatory Notes on Document	4	Final Work	22
Preliminary Work	5	Template for Fuel Standpipe	23
Heater installation location	5	Template for fuel tank sending unit	23
Preparing electrical system	6	Operating Instructions for End Customer	24
Electrical Connections	7		
Fan control for manual air conditioning	8		
Automatic air-conditioning fan control	9		
Remote option (Telestart)	11		

**Validity**

Manufacturer	Model	Type	EG-BE No./ABE
VW	Transporter	T5	L148

Engine type	Engine model	Output in kW	Displacement in cm <sup>3</sup>
AXC	Diesel	63	1896

Vehicle and engine types and equipment variants not listed in this installation documentation have not been tested. However, installation according to this installation documentation may be possible. The installation location of a digital timer and summer/winter switch should be confirmed with the end customer before installation.

## Heater/Installation Kit

Quantity	Description	Order No.:
1	Retail accessories <i>Thermo Top E / C</i>	See price list
1	Installation kit VW T5 Diesel	9014130A
1	Heater control	See Price list

### Also required for automatic air-conditioning:

Quantity	Description	Order No.:
1	A/C kit	9014133A

### Heater recommended for the respective vehicle class:

Vehicle	Heater
Compact car	Thermo Top E
Mid-size car, station wagon	Thermo Top C

The selection of the heater is based on the passenger compartment size of the vehicle and the level of comfort required by the customer.



## Foreword

This installation documentation applies to vehicles VW T5 with an Diesel engine - for validity, see page 2 - from model year 2004 and later, assuming technical modifications to the vehicle do not affect installation, any liability claims excluded. Depending on the vehicle version and equipment, modifications may be necessary during installation with respect to this installation documentation.

However, the stipulations in the "installation documentation", the "operating instructions" and the "installation instructions" for the *Thermo Top E / C* must always be observed.

The corresponding rules of technology and any information from the vehicle manufacturer should be observed during the installation work.

## General Instructions

Installation should be carried out according to the general, standard rules of technology. Unless specified otherwise, fasten hoses, lines and wiring harnesses to original vehicle lines and wiring harnesses using cable ties.

Sharp edges should be fitted with rub protection (split-open plastic hose).

Spray unfinished body areas, e.g. drilled holes, with anti-corrosion wax (Tectyl 100K, Order No. 111329).

When installing an IPCU, check or adjust the corresponding settings before installation.

## Special Tools

- Torque wrench for 2.0 - 10 Nm
- Hose clamping pliers
- Metric thread-setter kit
- Webasto Thermo Test Diagnosis

## Explanatory Notes on Document

You will find an identification mark on the outside top right corner of the page in question to provide you with a quick overview of the individual working steps.

### Mechanical system

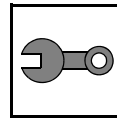

### Electrical system

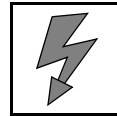

### Coolant circuit

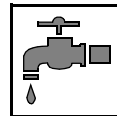

### Fuel

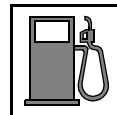

### Exhaust gas

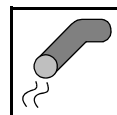

### Combustion air

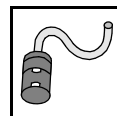

Special features are highlighted using the following symbols:



Specific risk of injury or fatal accidents.



Specific risk of damage to components.



Specific risk of fire or explosion.



Reference to general installation instructions of Webasto components or to the manufacturer's vehicle-specific documents.



Reference to a special technical feature.

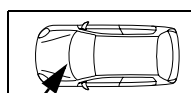
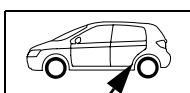

The arrow in the vehicle icon indicates the position on the vehicle and the viewing angle.

## Preliminary Work

### WARNING!

- Disconnect the battery "earth" or "ground" connection.
- Depressurise the cooling system.
- Copy the factory number from the original type label to the duplicate type label.
- Remove years that do not apply from the duplicate label.
- Attach the duplicate label (type label) in the appropriate place.
- Remove battery cover
- Open the fuel tank cap, ventilate the tank.
- Close the fuel tank cap again.
- Remove underbody trim at the right bottom entrance
- Remove original vehicle circulating pump
- Remove fuel tank according to manufacturer's specifications
- Remove the fuel-tank sending unit in accordance with manufacturer's instructions.
- Remove the glove compartment (only with automatic air-conditioning).
- Remove footwell trim at the right (only for automatic air-conditioning)

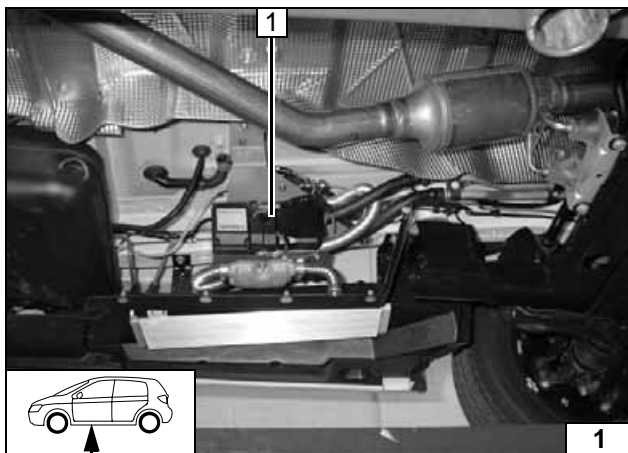

### Heater installation location

1 Heater

Installation location

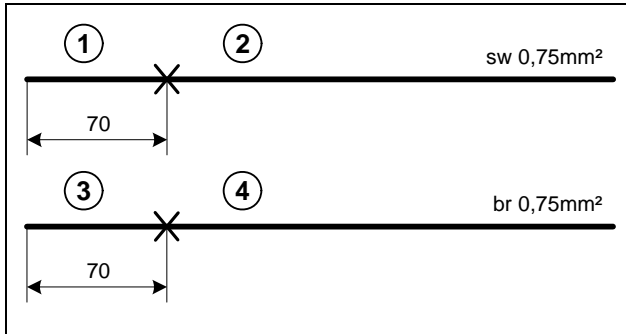

**Preparing electrical system**

**For all vehicles**

Wire sections 1, 2, 3, 4 will be needed for the connection from K3.1.

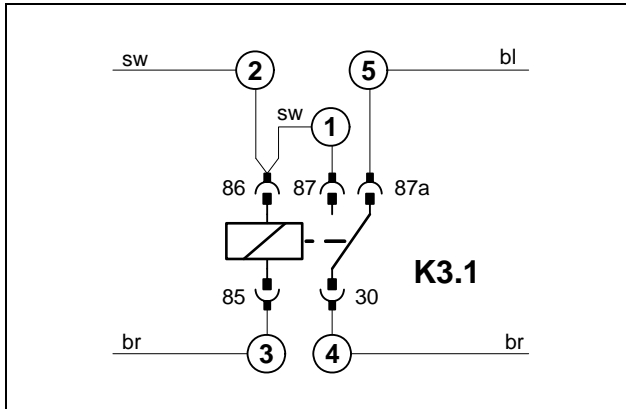

Make connections with provided tab receptacles.

Connect brown (br) wire 3 of K3.1/85 to K3/85. Draw blue (bl) 5, brown (br) 4 and black (sw) wires 2 into the provided protective sleeving.

- 1 Black (sw) wire cut to 70mm length
- 2 Remaining black (sw) wire.
- 3 Brown (br) wire cut to 70mm length
- 4 Remaining brown (br) wire.
- 5 Provided blue (bl) wire

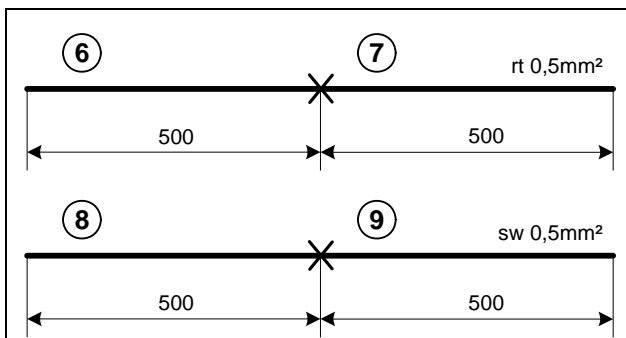

**Only with automatic air-conditioning**

Wire sections 6, 7, 8, 9 will be needed for the IPCU connection

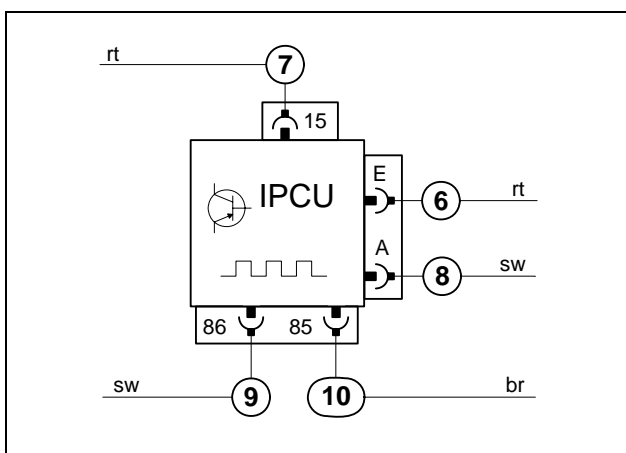

Make connections with provided tab receptacles according to wiring diagram.

10 Provided 300mm long brown (br) wire

**WARNING!**

The IPCU is to be programmed with the help of the PC diagnosis and the thermostat software - from version 2.07 onwards - as follows:

- Duty cycle 35%
- Frequency 100 Hz
- Voltage 2.88V
- Function low site



**Cutting wires to size**



**Premounting K3.1**



**Cutting wires to size**



**Premounting IPCU**





**Electrical system**

**Fuse holder, K3 relay**

- 2 Retaining plate of fuse holder, 5.5x13 self-tapping screw, washers
- 1 K3.1 relay, 5.5x13 self-tapping screw, washer
- 3 K3 relay, 5.5x13 self-tapping screw, washer

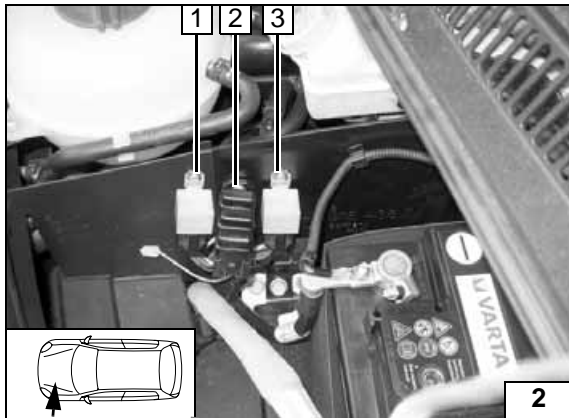

**Wiring harness pass through**

- 1 Protective rubber plug

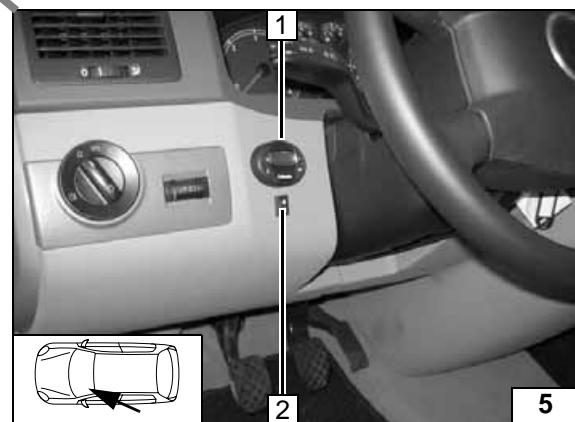
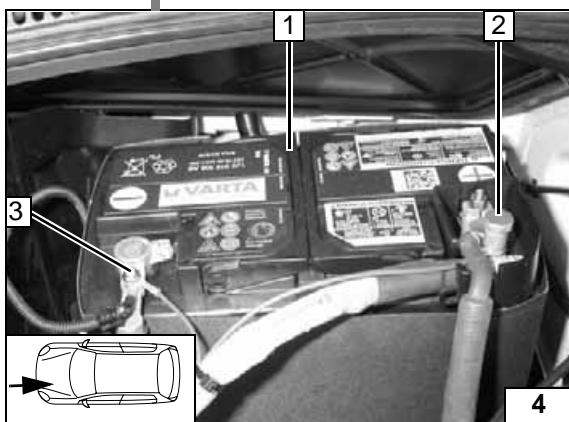
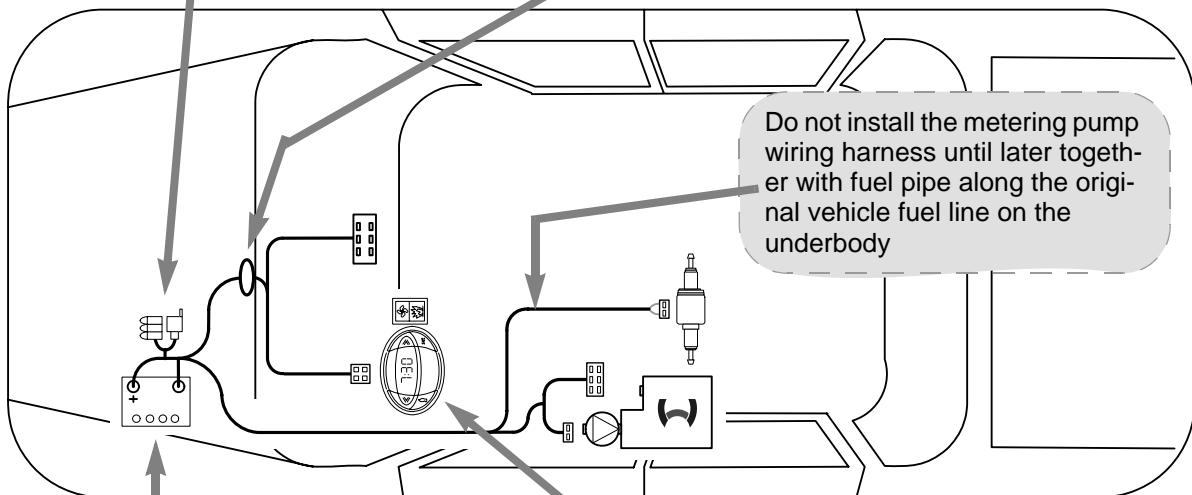
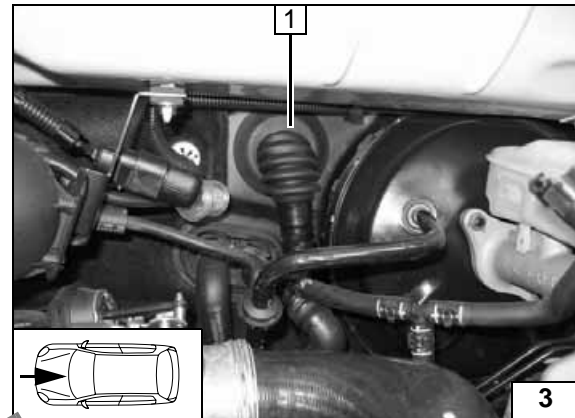

**Connecting power supply**

- 1 Battery
- 2 Earth connection on existing bolt
- 3 Positive connection on existing bolt, M6 flanged nut

**Digital timer / summer/winter switch option**

- 1 Digital timer
- 2 Summer/winter switch option



Wiring harness routing diagram

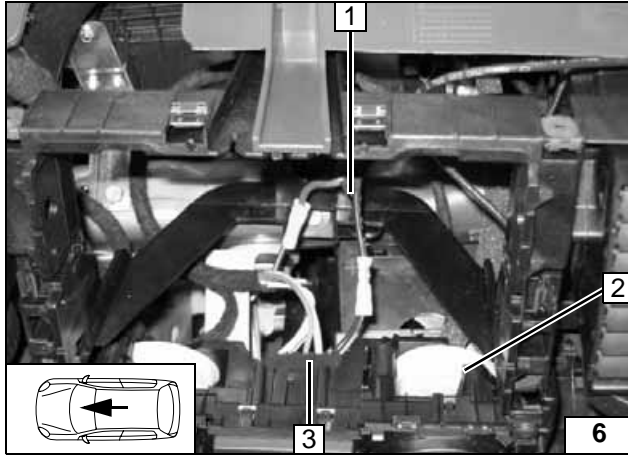

### Fan control of manual air conditioning

Connection to 5-pin connector of fan switch Pin 1.  
Make connections with provided tab receptacles according to wiring diagram.

- 1 Wiring harness of fan control
- 2 Control unit
- 3 5-pin connector



Connect-  
ing fan mo-  
tor



Wiring dia-  
gram for  
manual air con-  
dition-  
ing

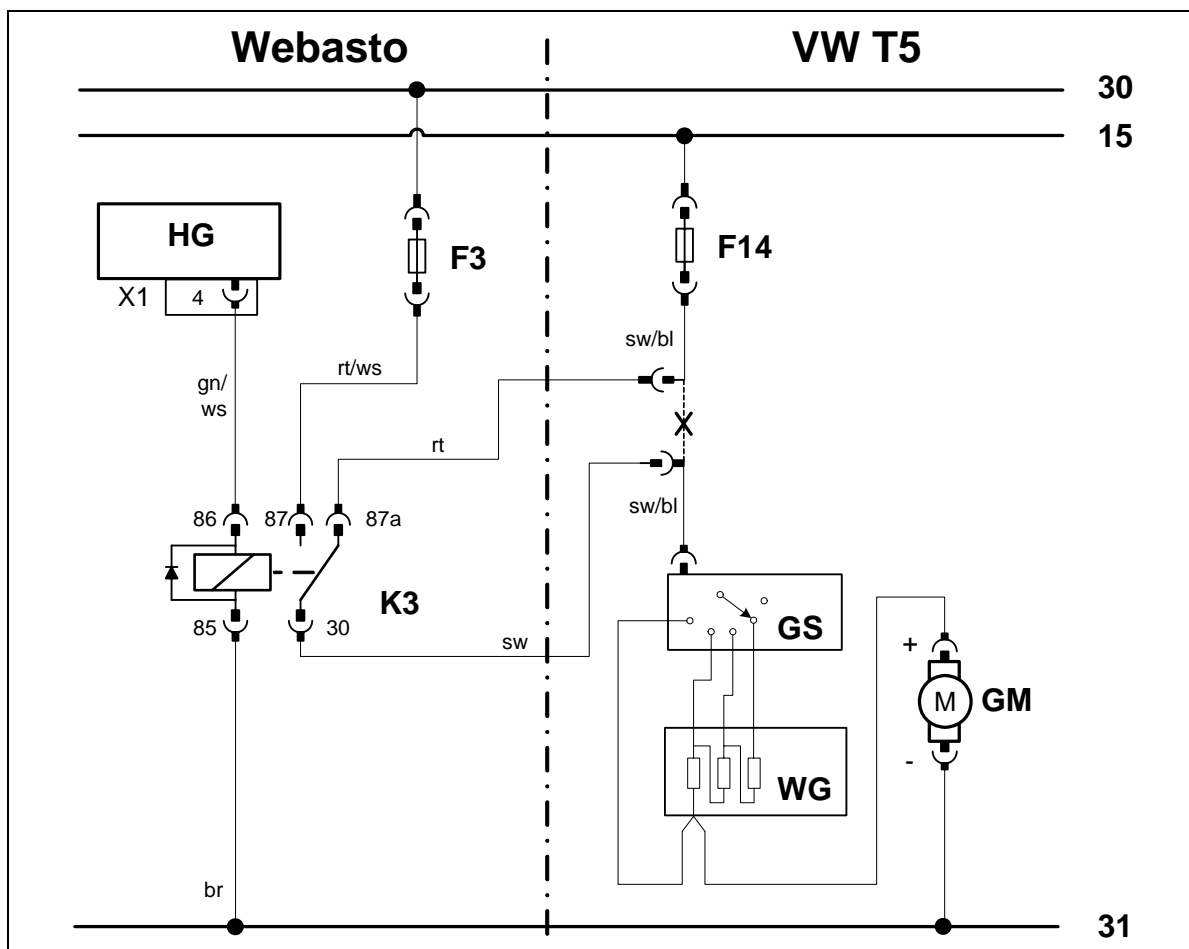

Webasto components		Vehicle components		Colours and symbols	
HG	Heater TT-C/E	GM	Fan motor	rt	red
X1	6-pin heater connector	GS	Fan switch	ws	white
F3	Fuse	WG	Resistor group	sw	black
K3	Fan relay	F14	30A fuse	br	brown
				gn	green
				bl	blue
				X	Cutting point
				Wiring colours may vary.	

Legend



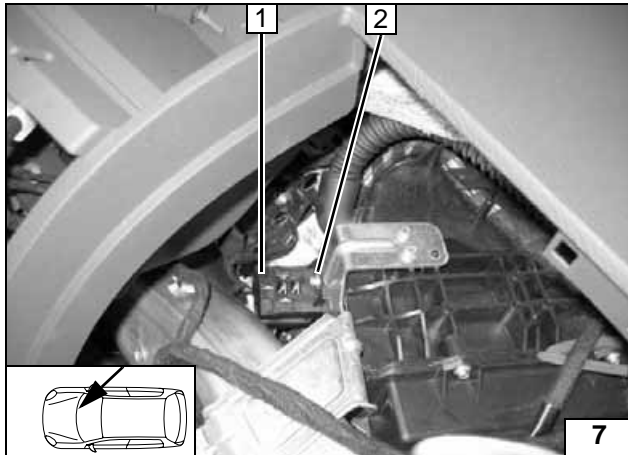

**Automatic air-conditioning fan control**

- 1 IPCU relay socket
- 2 Original vehicle bolt



**Installing IPCU receptacle housing**

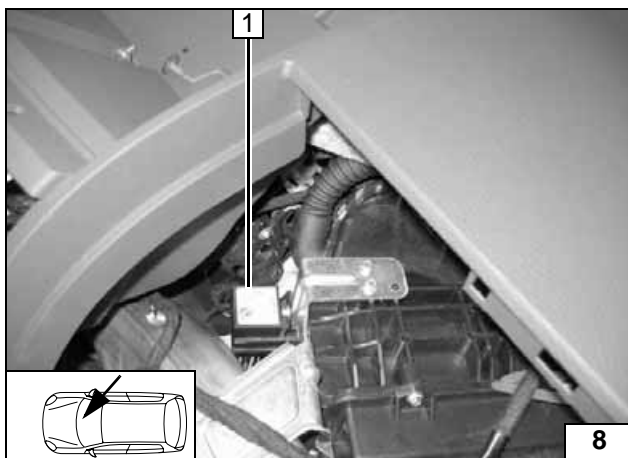

- 1 IPCU

**Installing IPCU**

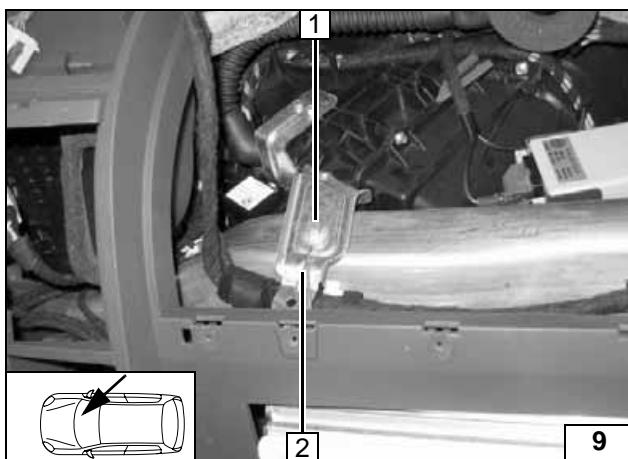

- 1 Original vehicle M6 bolt
- 2 Earth wire from IPCU

**IPCU earth connection**

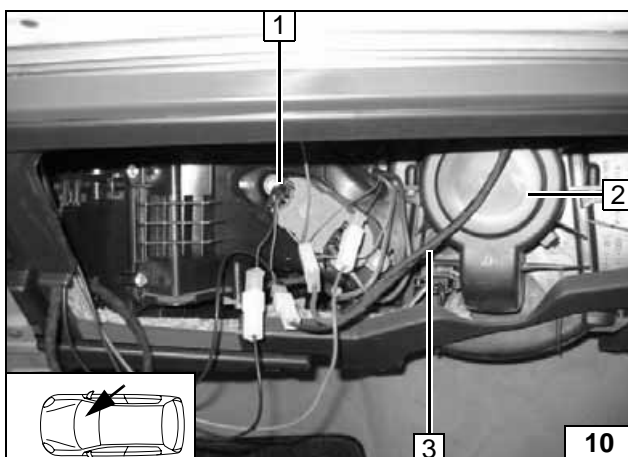

Connection on 4-pin T4G connector from fan controller.  
Make connections with provided tab receptacles according to wiring diagram.

- 1 4-pin T4g connector
- 2 Fan motor
- 3 Wiring harness of fan control



**Connecting IPCU to fan controller**

The 25A fuse in the heater wiring harness is to be replaced with the fuse 1A provided.



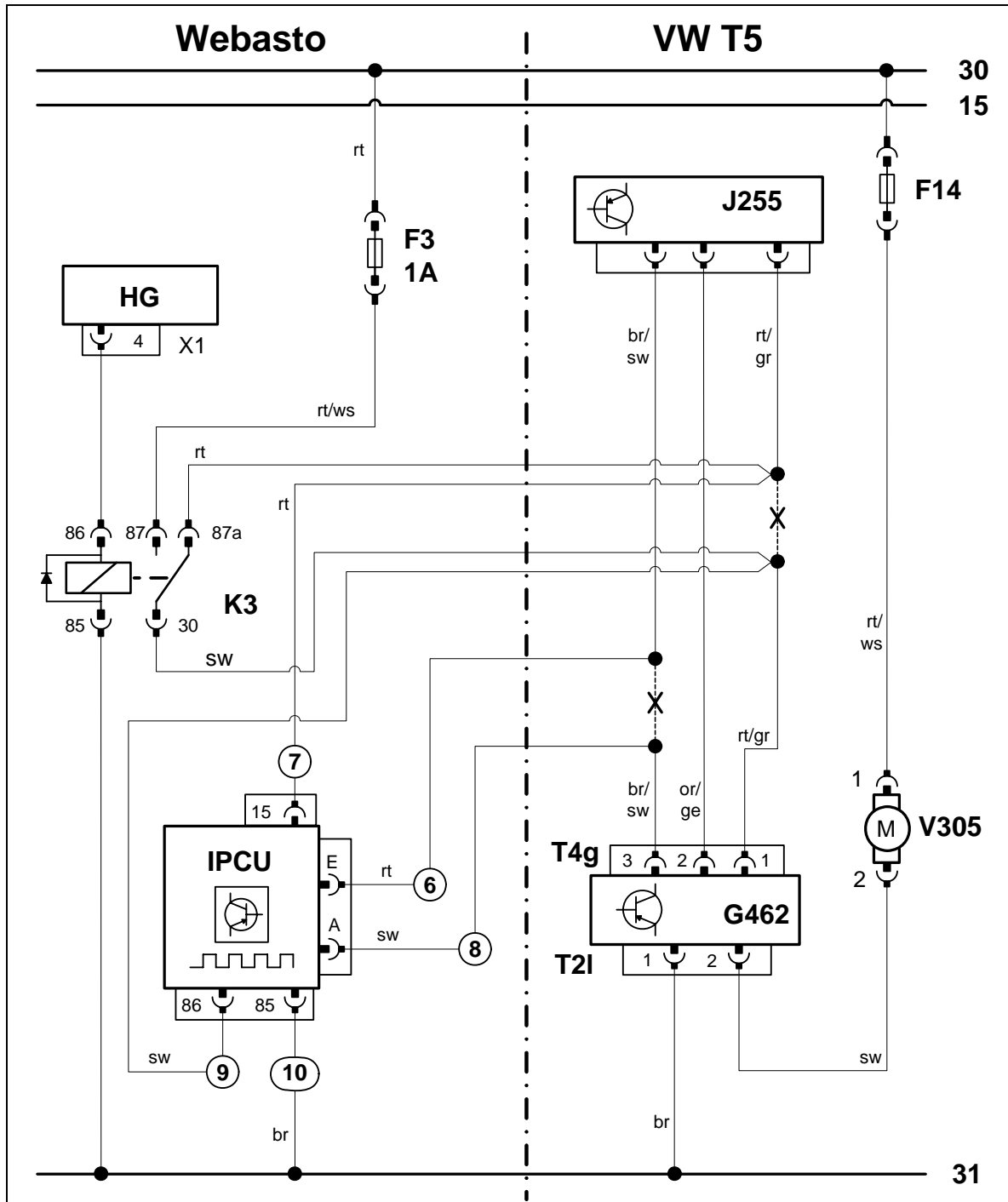

Wiring diagram of automatic air-conditioning

Webasto components		Vehicle components		Colours and symbols	
HG	Heater TT-C/E	V305	Fan motor	rt	red
F3	1A fuse	J255	A/C control panel	ws	white
K3	Fan relay	G462	Fan controller	sw	black
IIPCU	Pulse width modulator	F14	Fan fuse	br	brown
		T4g	Connector on G462	gn	green
		T2l	Connector on G462	bl	blue
				ge	yellow
				or	orange
				gr	gray
<b>IPCU adjustment values:</b>				X	Cutting point
Duty cycle:	35%			Wiring colours may vary.	
Frequency:	100Hz				
Voltage:	2.88V				
Function:	Low side				

Legend

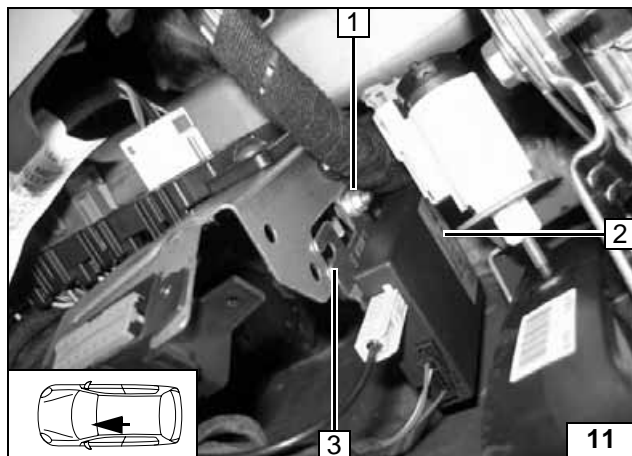

**Remote option (Telestart)**

- 1 M5x16 bolt, flanged nut on existing hole
- 2 Telestart
- 3 Telestart bracket

**Installing receiver**

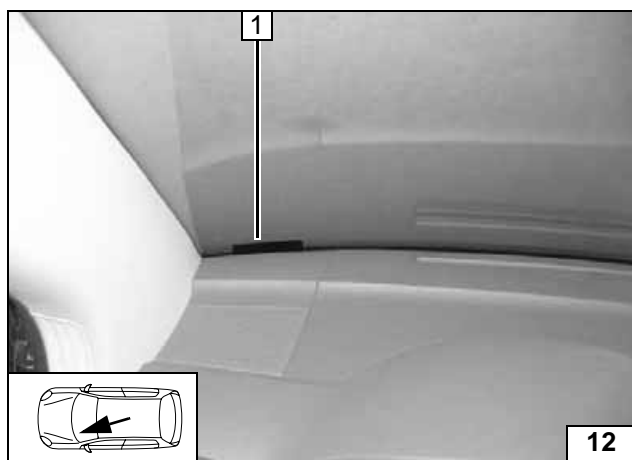

- 1 Antenna

**Installing antenna**

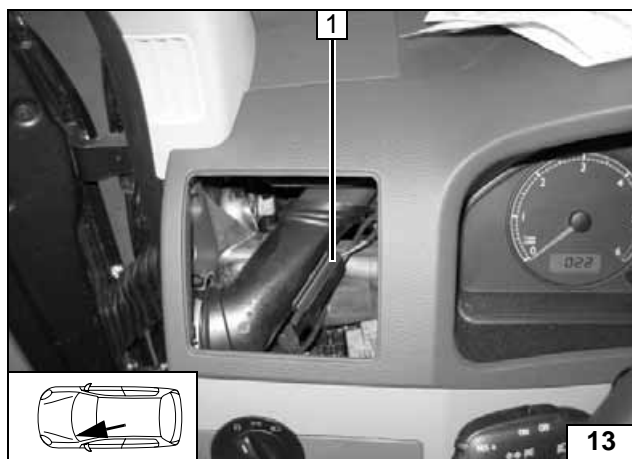

**Only with Telestart T100 HTM**

- 1 Temperature sensor fastened with double-sided adhesive tape

**Installing temperature sensor**

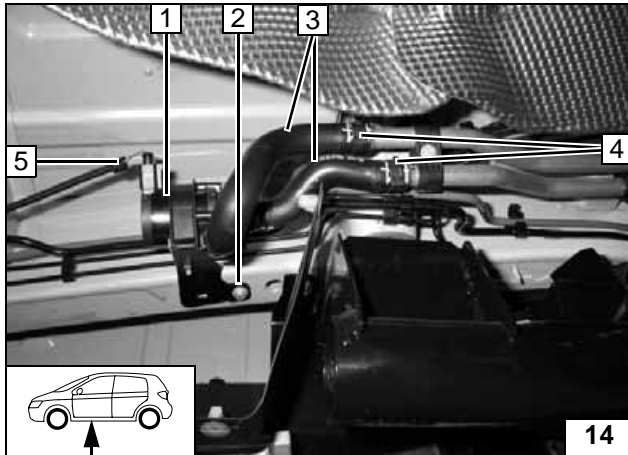
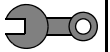

**Preparing installation location**

Wiring harness **5** will be required later to control the circulating pump of the heater

- 1 Discard circulating pump with bracket
- 2 Discard original vehicle bolt
- 3 Discard original vehicle hoses
- 4 Spring clips [2x] will be reinstalled



**Removing circulating pump**

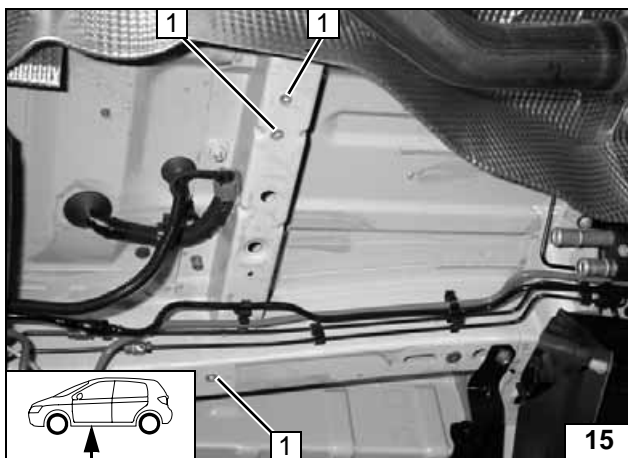

- 1 M6 rivet nuts in existing hole [3x]

**Installing rivet nut**

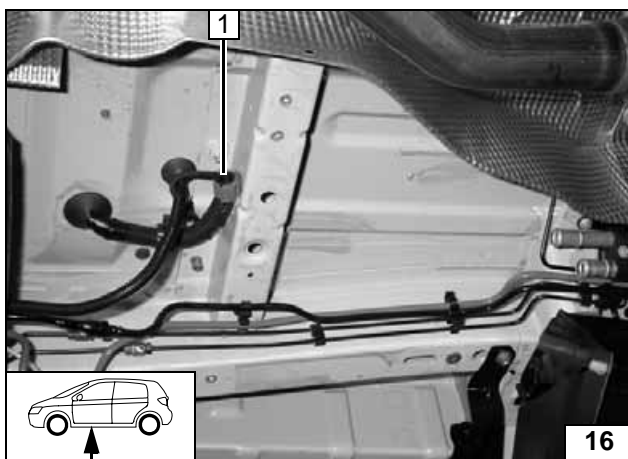

- 1 Clip original vehicle circulating pump wiring harness in existing hole

**Re-clipping wiring harness**

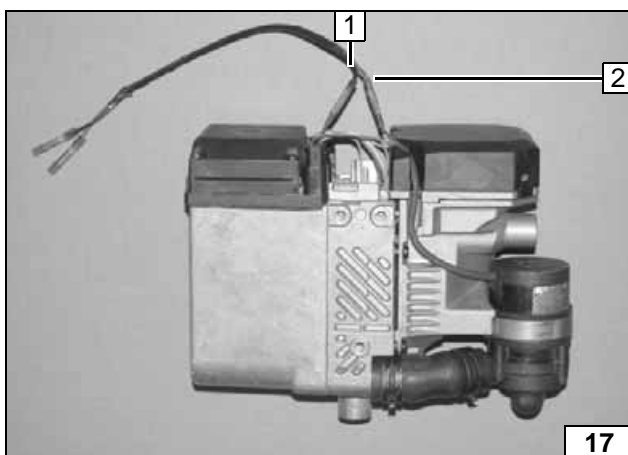

**Preparing heater**

Remove middle heater cover.  
Cut black (sw) wire of connector X5 Pin 1 of circulating pump and connect provided additional brown (br) and black (sw) wires to bumper according to the wiring diagram.

- 1 250mm long black (sw) wire
- 2 300mm long brown (br) wire



**Premounting wires on heater**

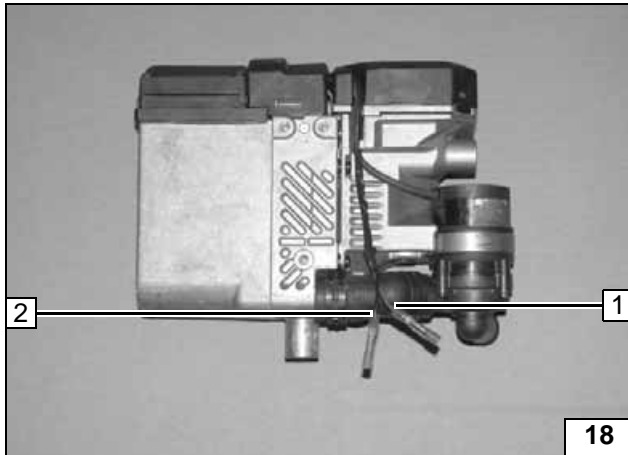
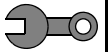

Route brown (br) and black (sw) additional wires to heater as shown.  
Reinstall heater cover.

- 1 300mm long brown (br) wire
- 2 250mm long black (sw) wire



Premounting wires on heater

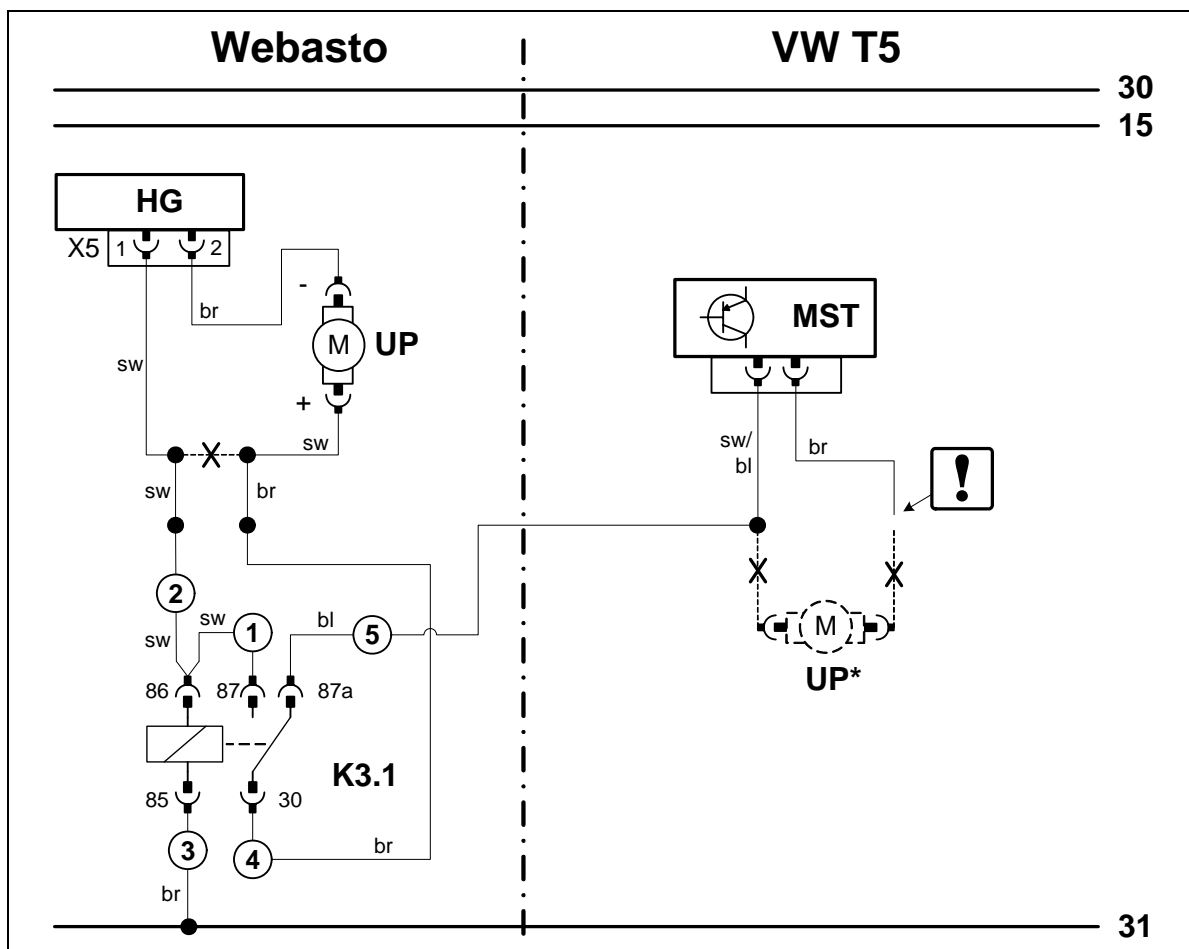

Wiring harness of circulating pump

Webasto components		VW components		Colours and symbols	
HG	Heater TT-C/E	MST	Engine control unit	sw	black
X5	2-pin UP connector on heater	UP*	Circulating pump	br	brown
				bl	blue
K3.1	Additional relay				
UP	Circulating pump				Insulate wire ends and tie back
				X	Cutting point

Legend

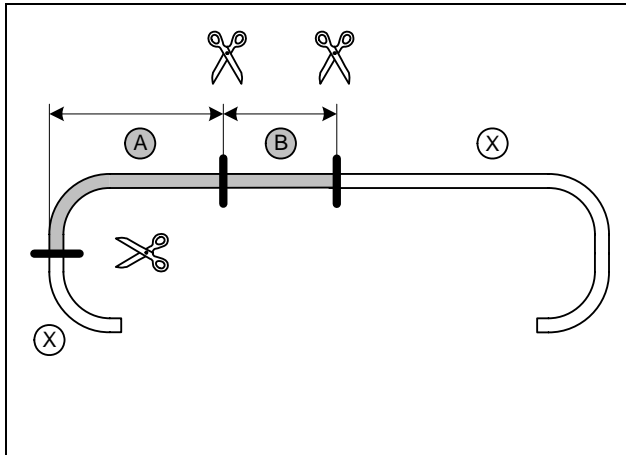
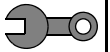

Discard section X.

A = 330mm  
B = 320mm



**Cutting hoses to size**

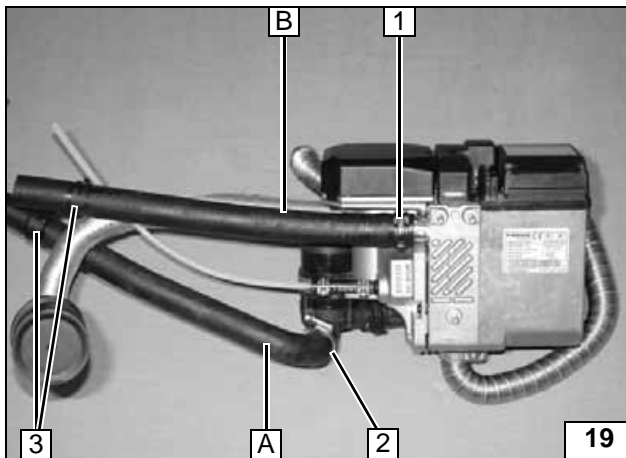

- 1 27mm dia. spring clip
- 2 27mm dia. hose clamp
- 3 Slide on original vehicle spring clip [2x]

**Premounting hoses**

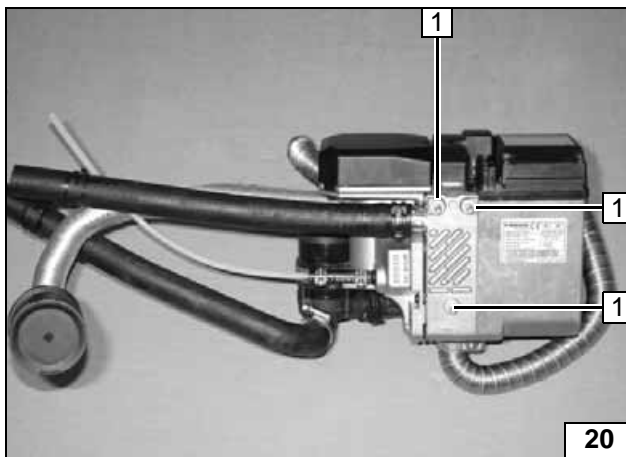

Eject screw bolt, tightening torque 10 Nm. Position one plain washer each between heater and short Eject stud bolt.

- 1 Short Eject stud bolt [3x]



**Premounting Eject screws**

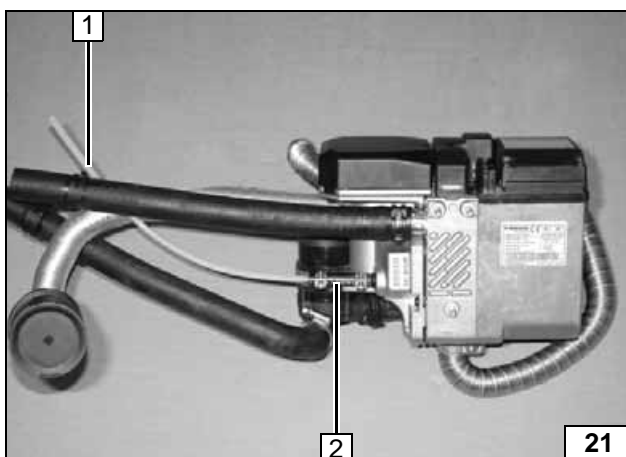

Cut off 350mm from provided Mecanyl fuel line 1, cut off 350mm.

- 2 Hose section, 10 mm dia. hose clamp [2x]



**Premounting fuel line on heater**

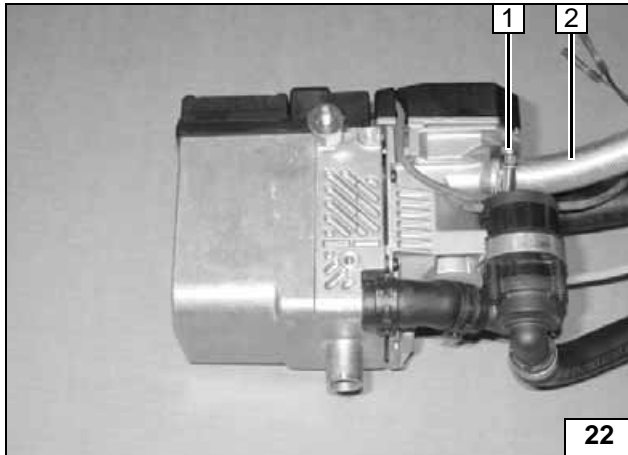
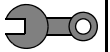

- 1 27mm dia. hose clamp
- 2 Combustion-air intake pipe



**Installing combustion-air intake line**

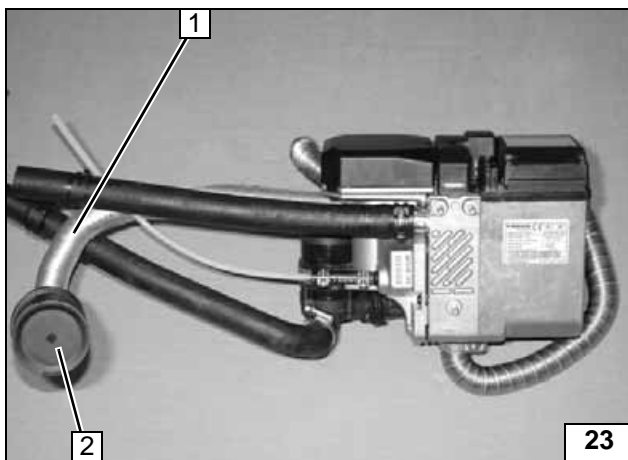

- 1 Combustion-air intake pipe
- 2 Combustion-air intake silencer

**Installing silencer**

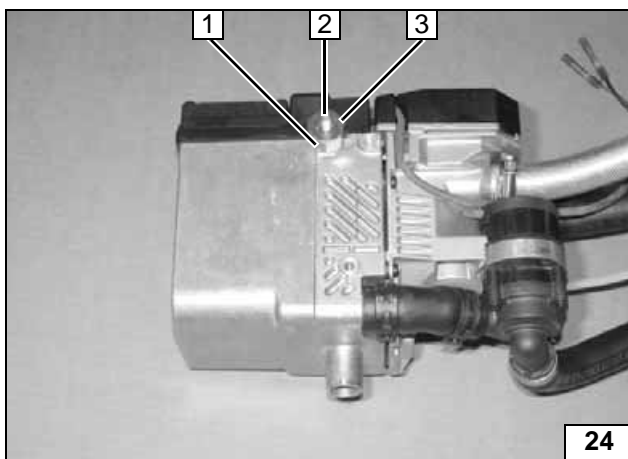

E-jet screw bolt, tightening torque 10 Nm.

- 2 Long E-jet stud bolt
- 1 Provided 8x15mm spacer nut
- 3 Large diameter washer



**Installing silencer**

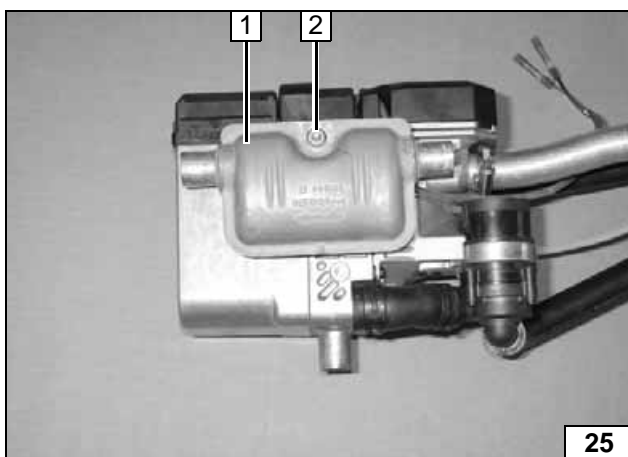

- 1 Silencer
- 2 E-jet stud bolt, M6 flanged nut

**Installing silencer**

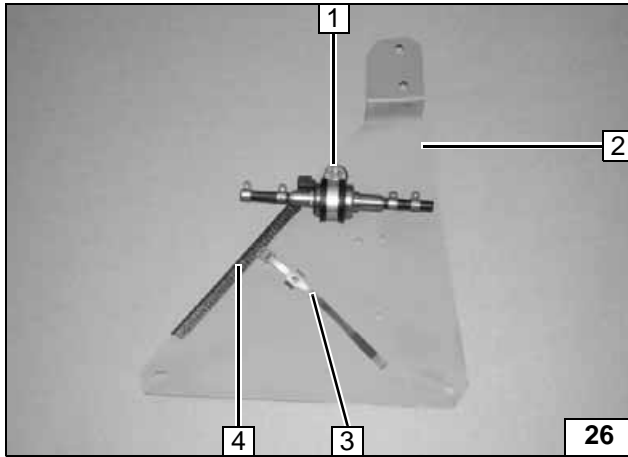
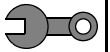

- 1 Silent block, rubber-coated p-clamp, measuring pump, M6 flanged nut [2x]
- 2 Bracket
- 3 Provided cable tie
- 4 Provided 200mm long edge protection

Preparing bracket

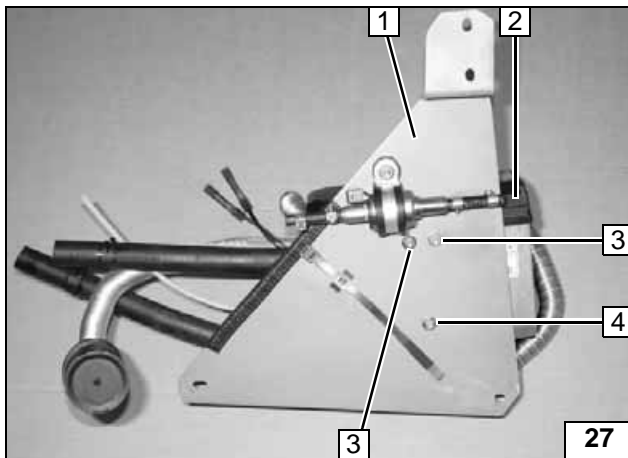

Position a plain washer between E-jot stud bolt 4 and premounted bracket 1

- 2 Premounted heater
- 3 E-jot stud bolt, M6 flanged nut [2x each]
- 4 Plain washer, M6 flanged nut



Premounting heater

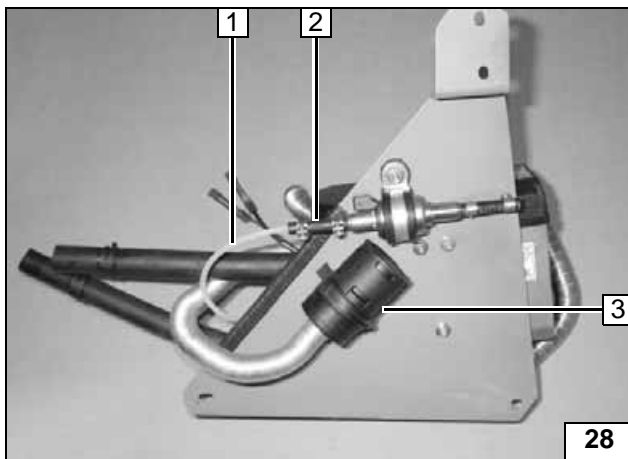

- 1 Mecanyl fuel line
- 2 Hose section, 10 mm dia. hose clamp [2x]
- 3 Combustion-air intake silencer with cable tie

Completing heater and bracket

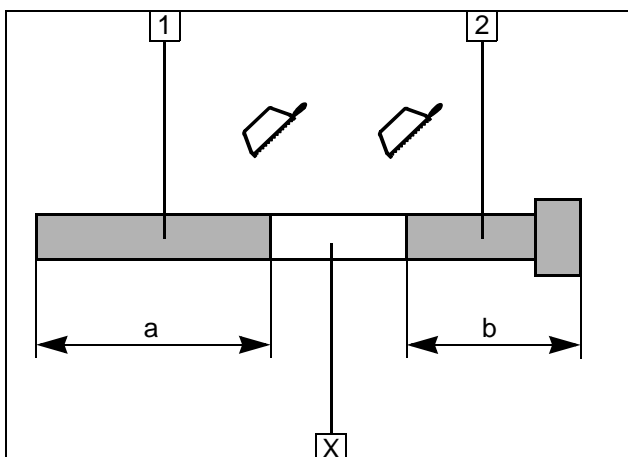

- 1 Exhaust pipe  
a = 380mm
- 2 Exhaust end section  
b = 150mm

Discard section X

Preparing exhaust pipe



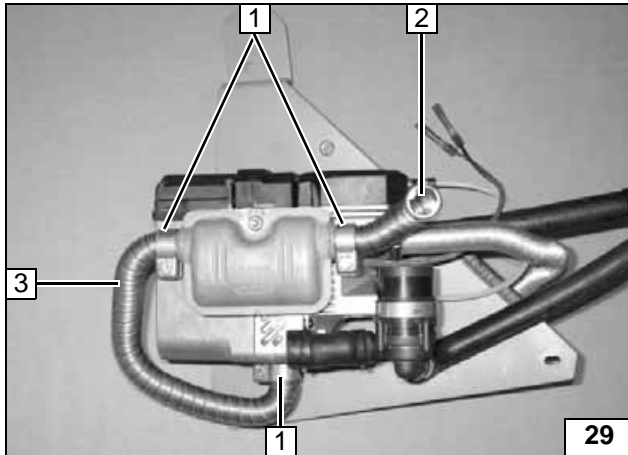
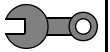

- 1 Hose clamp [3x]
- 2 Exhaust end section
- 3 Exhaust pipe

Installing exhaust pipe

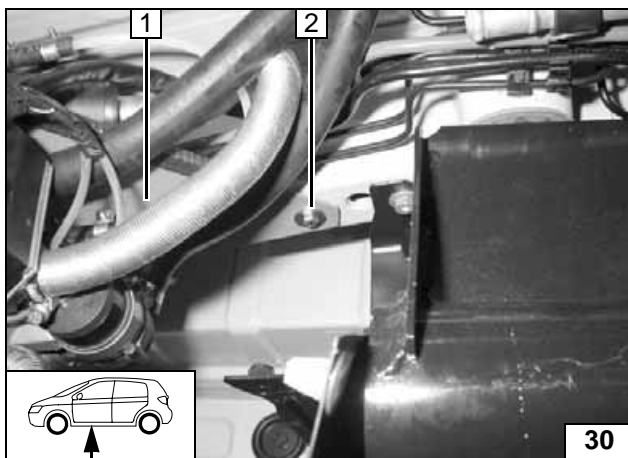

**Installing heater**

- 1 Pre-installed device
- 2 M6x20 bolt, spring lockwasher, large diameter washer, in existing M6 thread



Installing heater

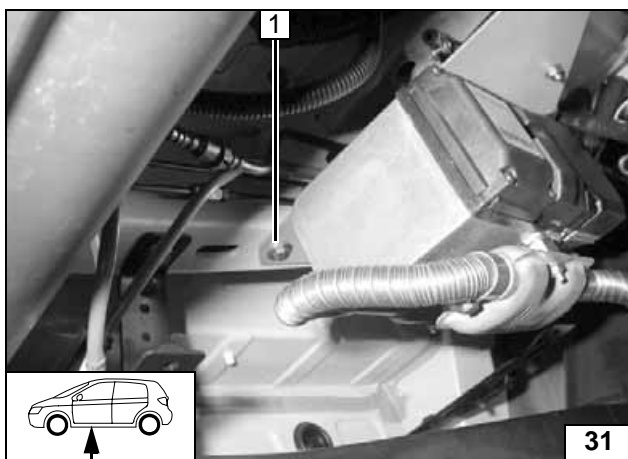

- 1 M6x20 bolt, spring lockwasher, large diameter washer, in existing M6 rivet nut

Installing bracket with heater

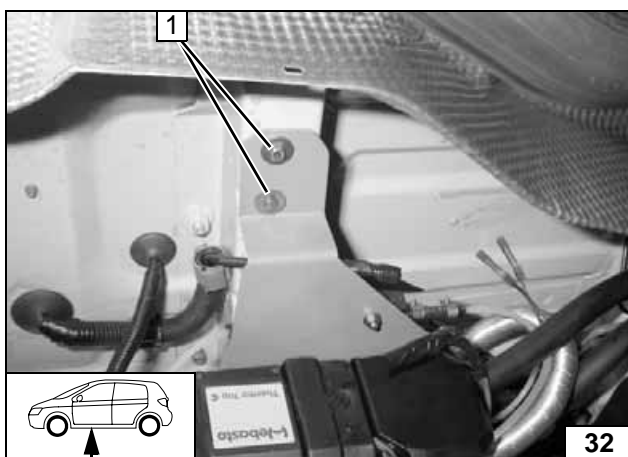

- 1 M6x20 bolt, spring lockwasher, large diameter washer, in existing M6 rivet nut [2x]



Installing heater with bracket





**Coolant circuit**

**WARNING!**

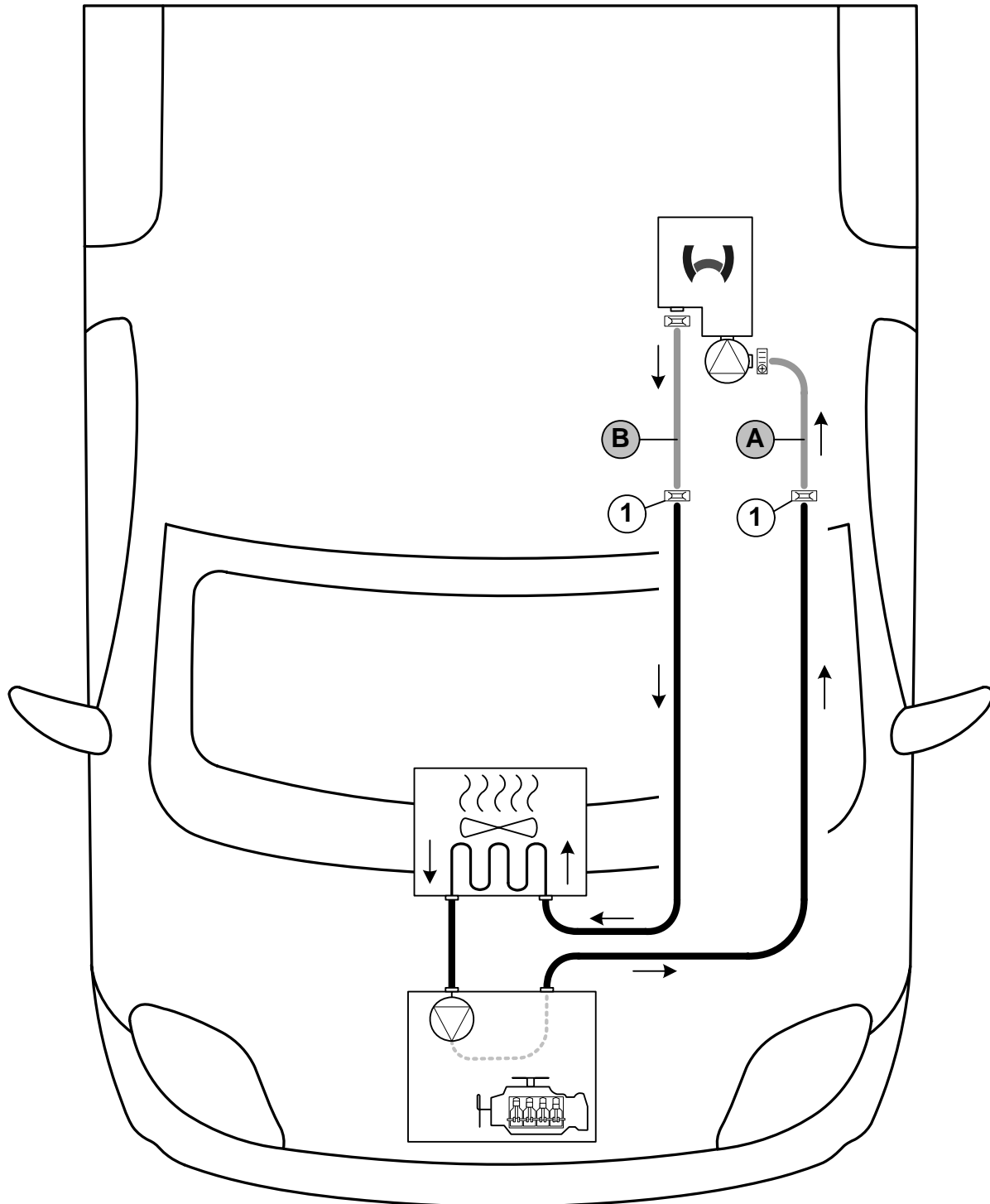
Any coolant running off should be collected in an appropriate container. Install hoses so that they are kink-free. Unless specified otherwise, always fasten using cable ties. Position clamps so that other hoses cannot be damaged. The heater must be filled with coolant when installing the hoses. The connection should be "inline" based on the following diagram:



Hose installation diagram

All non designated spring clips  = 27 mm dia.  
 Non designated hose clamp  = 20-27 mm dia.  
 1 = Original vehicle spring clip  [2x].



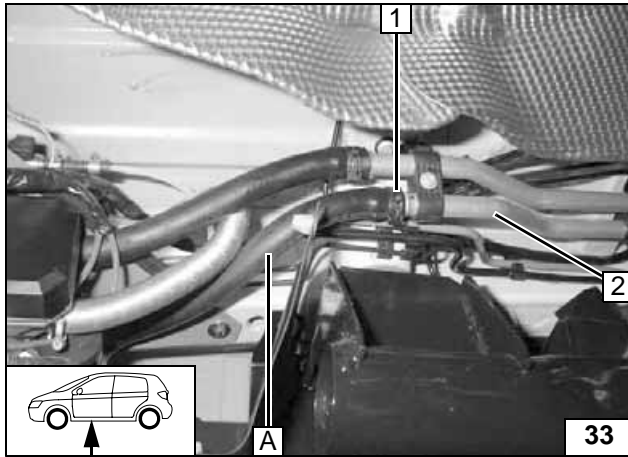

- 1 Original vehicle spring clip
- 2 Engine outlet pipe

**Connect-  
ing to en-  
gine outlet**

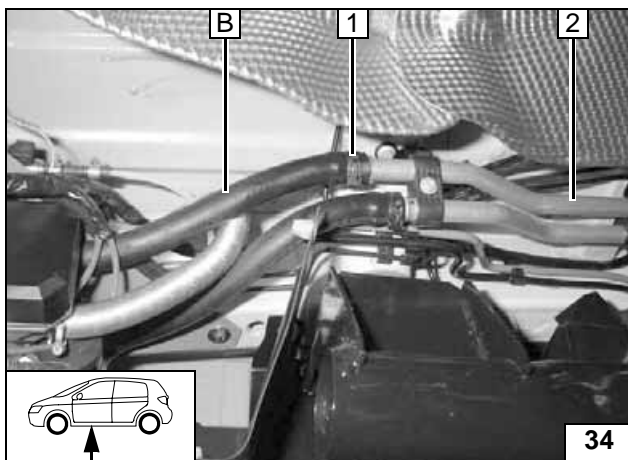

- 1 Original vehicle spring clip
- 2 Heat exchanger inlet pipe

**Connect-  
ing to heat  
exchanger  
input**

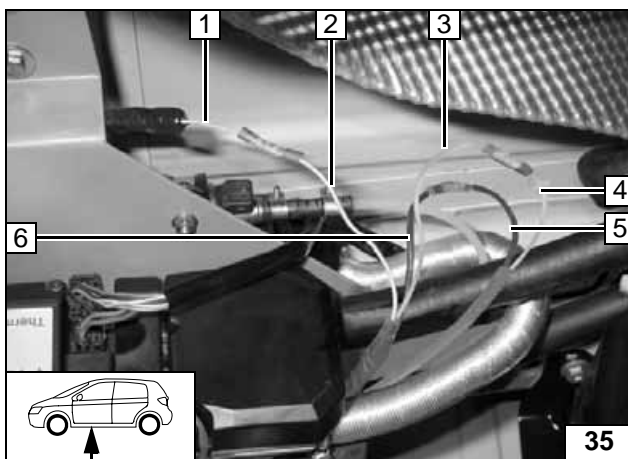

Make connections as shown in wiring diagram Page 13. Insulate brown (br) wire of original vehicle circulating pump and tie back.

- 1 Black/blue (sw/bl) wire of original vehicle circulating pump
- 2 Blue (bl) wire from K3.1/87a
- 4 Prepared 300mm long brown (br) wire
- 3 Brown (br) wire from K3.1/30
- 5 Prepared 250mm long black (sw) wire
- 6 Black (sw) wire from K3.1/86



**Electrical  
connec-  
tion to cir-  
culating  
pump**



**Fuel**

**CAUTION!**

Open the vehicle's fuel tank cap, ventilate the tank and then re-close the tank lock.

Catch any fuel running off in an appropriate container.

Install fuel line and metering pump wiring harness so that they are protected against stone impact. Unless specified otherwise, always fasten using cable ties.

Mount the fuel line and wiring harness with rub protection on sharp edges.

**WARNING!**

The fuel line and wiring harness are routed to the metering pump as shown in the wiring harness routing diagram.

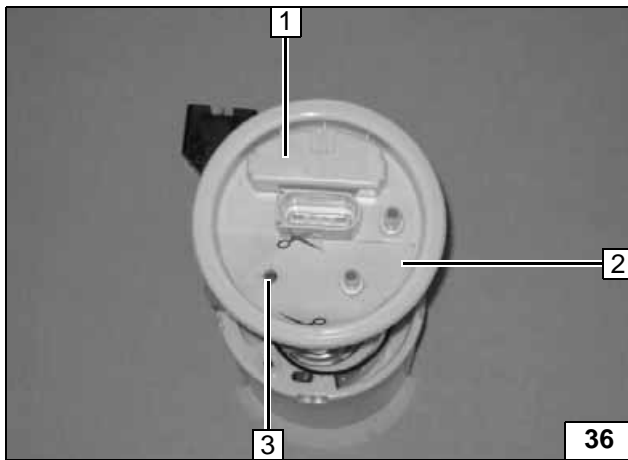

Remove fuel tank and fuel-tank sending unit in accordance with manufacturer's specifications.

- 1 Fuel-tank sending unit
- 2 Template provided
- 3 Copy hole pattern, 6 mm dia. hole

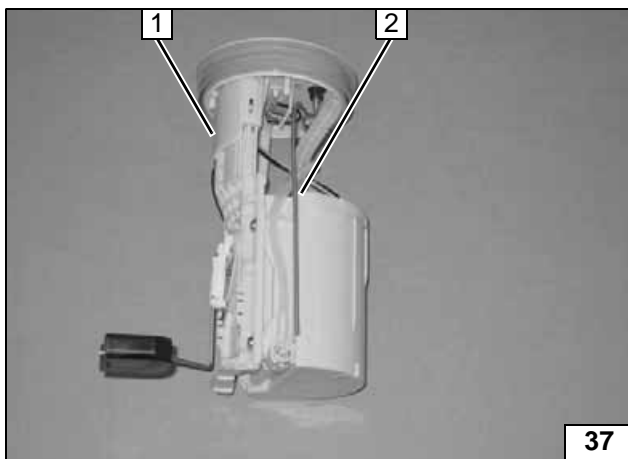

Shape fuel standpipe according to template, cut to length and install, see "installation instructions".

- 1 Fuel-tank sending unit
- 2 Fuel standpipe

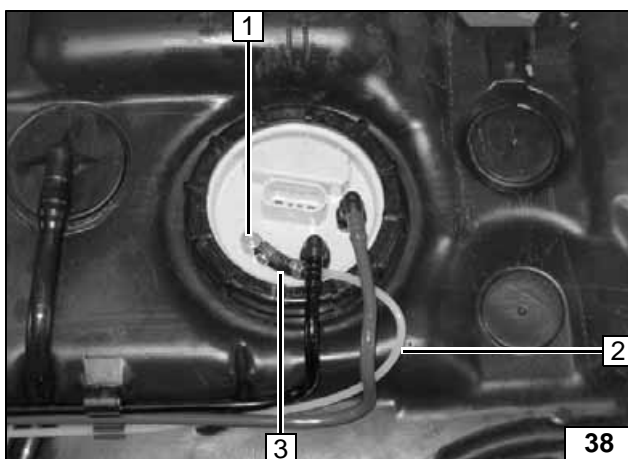

- 1 Fuel standpipe
- 2 Mecanyl fuel line
- 3 Hose section, 10mm dia. hose clamp [2x]



**Removing fuel**



**Installing fuel standpipe**

**Connecting fuel line**

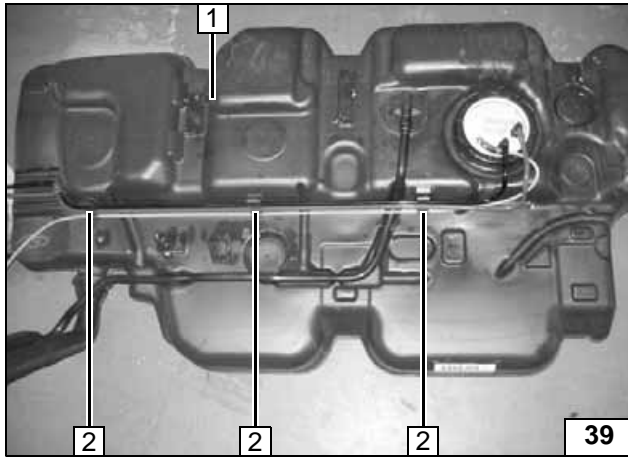

- 1 Fuel tank
- 2 Mecanyl fuel line on existing mounting points [3x]

Routing fuel line

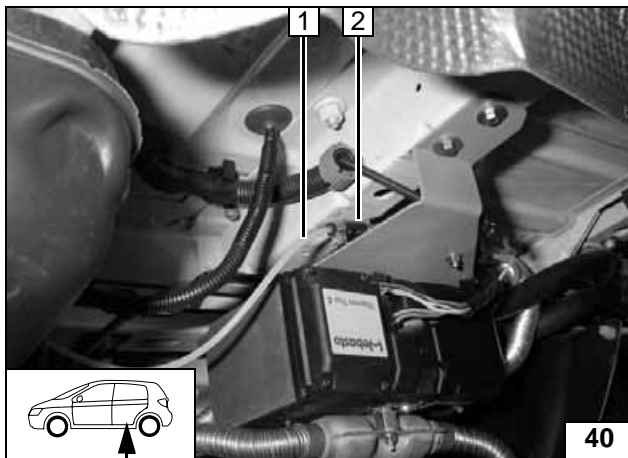

- 1 Mecanyl fuel line
- 2 Pre-installed hose section

Connect-  
ing meter-  
ing pump

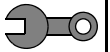

## Final Work

### WARNING!

Mount removed parts in reverse order.

Check all hoses, hose, spring and Caillau clamps, as well as all electrical connections for firm seating. Secure all loose cables using cable ties.

Spray the heater components with anti-corrosion wax (Tectyl 100K, Order No. 111329).

- Connect the battery
- Fill and bleed the coolant circuit according to the vehicle manufacturer's specifications.
- Set digital timer, teach telestart transmitter
- Make settings on A/C control panel according to the "Operating Instructions for End Customer".
- Place the "Switch off parking heater before refuelling" sticker near the filler neck.
- See installation instructions for initial start-up and function test

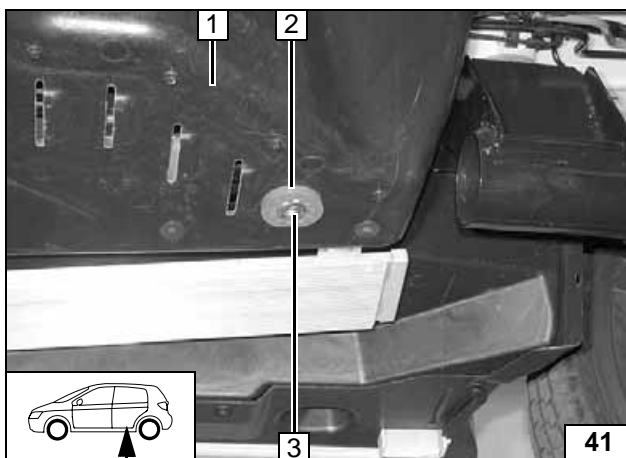

- 1 Underride protection
- 2 42 mm dia. hole, red (rt) rubber isolator with groove
- 3 Exhaust end section



**Cut out underride protection and insert protective rubber isolator**

**Webasto**  
*Feel the drive*

Webasto AG  
 Postfach 80  
 D-82132 Stockdorf / Germany  
 National Hotline: 01805 93 22 78  
 (14 Cent aus dem deutschen Festnetz)  
 Hotfax: 0395 5592 353  
 Hotmail: technikcenter@webasto.com  
 http://www.webasto.com

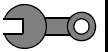

Template for Fuel Standpipe

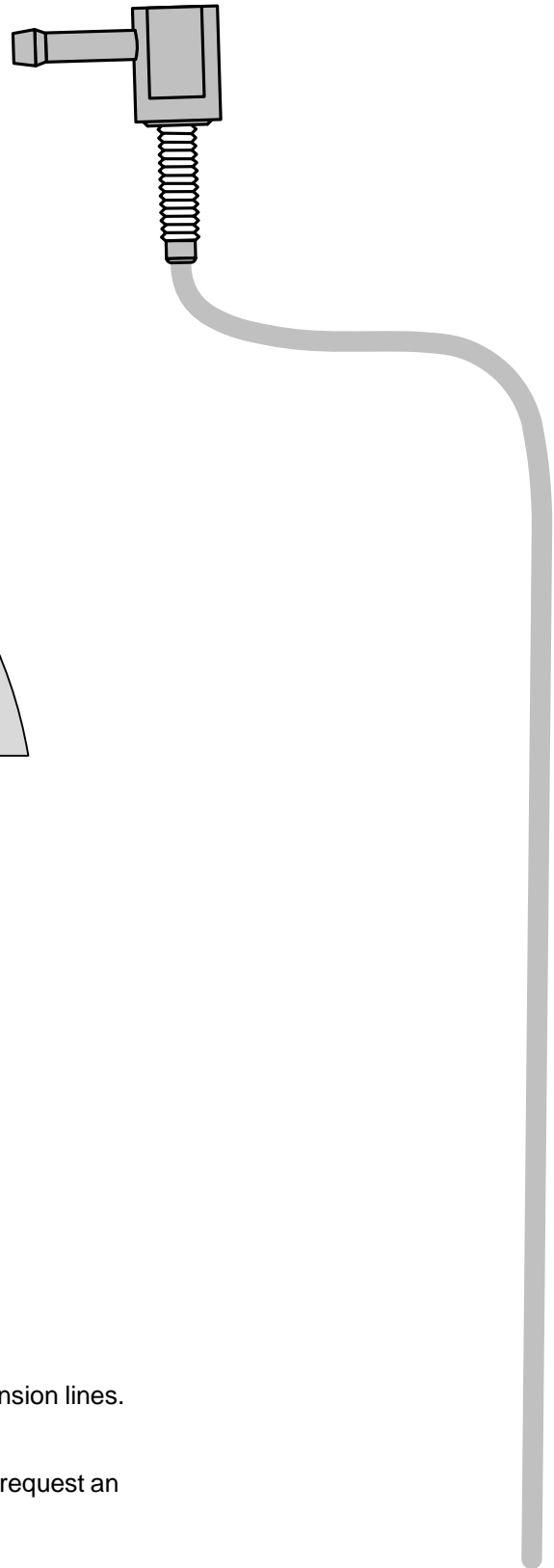

Template for fuel tank sending unit

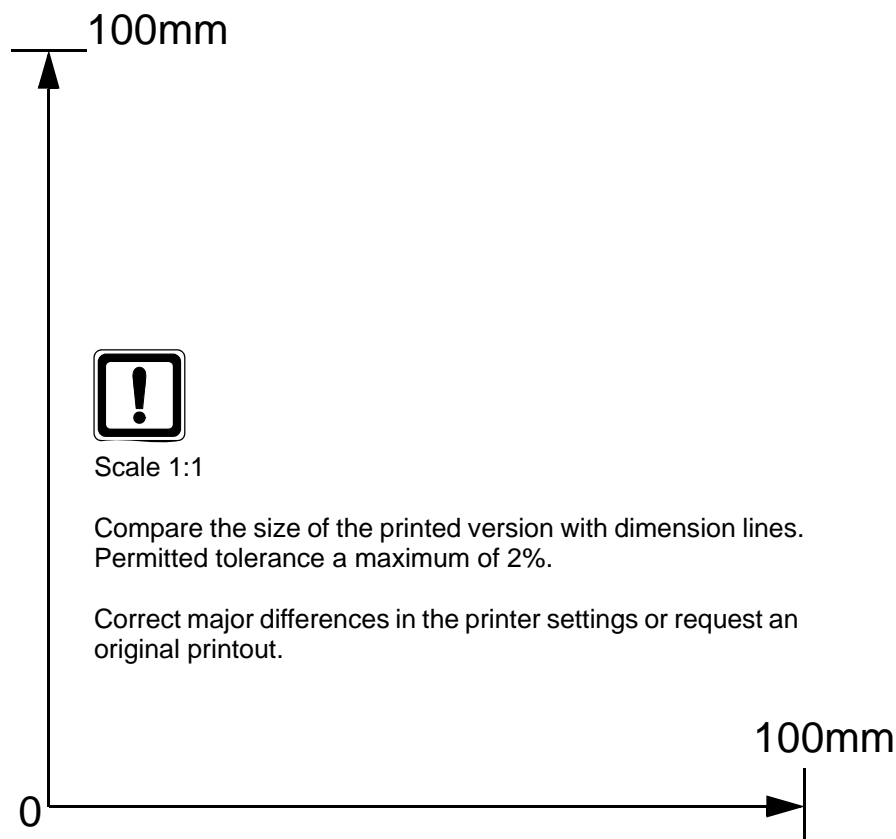
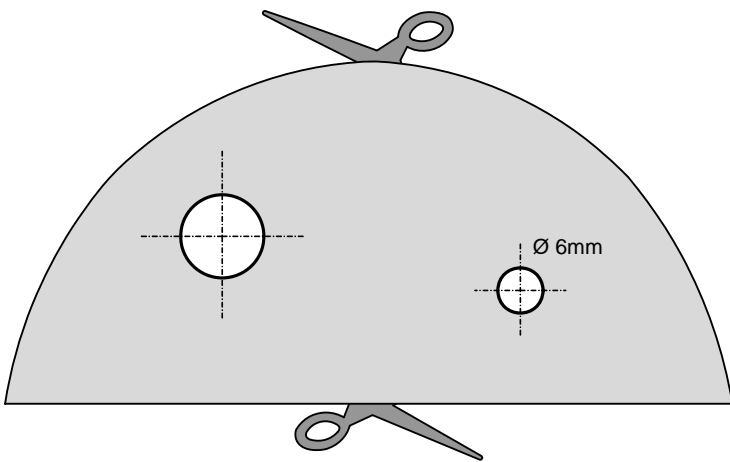

Scale 1:1

Compare the size of the printed version with dimension lines.  
Permitted tolerance a maximum of 2%.

Correct major differences in the printer settings or request an original printout.

## Operating Instructions for End Customer

Please remove page and add to the vehicle operating instructions.



**Note:**

We recommend matching the heating time to the driving time.

Heating time = driving time

**Example:**

For a driving time of approx. 20 min. (in one direction), we recommend not exceeding a switch-on time of 20 min.

If the summer/winter switch option has been installed, this must be switched in accordance with the time of year. The heater will then heat in the position Winter  and in the position Summer  it will only switch on the vehicle fan to ventilate the vehicle interior.

Before parking the vehicle, make the following settings:

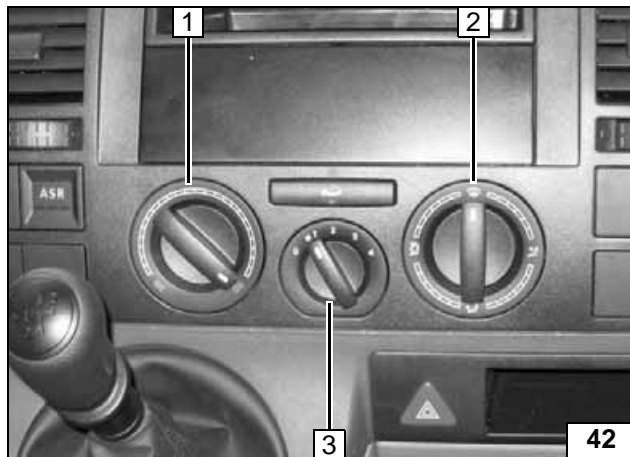

- 1 Set temperature to "max."
- 2 Air outlet to windscreen
- 3 Set fan to level "1", or possibly "2"

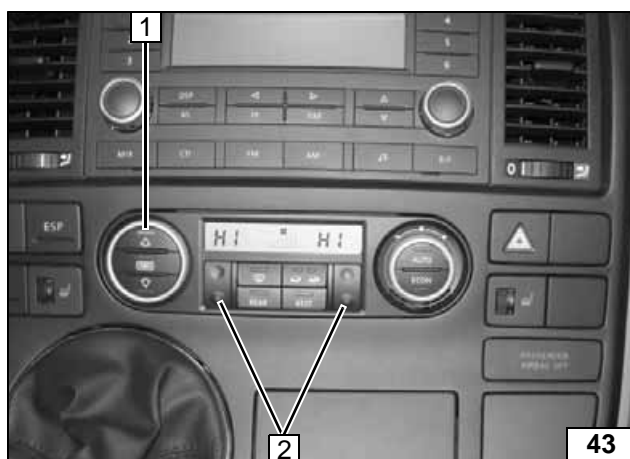

- 1 Air outlet to windscreen
- 2 Set temperature to "max."



For vehicles without automatic air-conditioning

For vehicles with automatic air-conditioning