

Water Heater Unit



Thermo Top E Additional Heater

00 0003

Thermo Top C Additional Heater

00 0002

Thermo Top P Additional Heater

00 0104

Installation Instructions

Audi A3

1.4 TFSI

from Model Year 2006

Left-hand drive vehicle



WARNING!

Hazard warning:

Incorrect installation or repair of Webasto heating systems may cause a fire or result in the emission of carbon monoxide, which can be fatal. Serious or fatal injuries can be caused as a result.

Specialist company training, technical documentation, specialized tools and equipment are required to install and repair Webasto heating and cooling systems.

NEVER attempt to install or repair Webasto heating or cooling systems if you have not successfully completed the company training and thereby acquired the required technical skills, or if you do not have access to the required technical documentation, tools and equipment needed to carry out correct installation and repairs.

ALWAYS follow all Webasto installation and repair instructions and observe all warnings.

Webasto does not accept any liability for defects and damage that are attributable to installation by untrained staff.

Audi A3

Table of Contents

Validity	2	Digital timer	10
Heater Unit/Installation Kit	3	Summer/winter switch option	10
Foreword	3	Remote option (Thermo Call)	11
General Instructions	3	Preassembling heater unit	12
Special Tools	3	Preparing installation location	13
Explanatory Notes on Document	4	Installing heater unit	14
Preliminary Work	5	Fuel Connection	15
Heater unit installation location	5	Coolant	18
Electrical system	6	Exhaust gas	23
Fuse holder and relay K3	7	Final Work	24
Climatronic fan controller	8	Operating Instructions for End Customer	25
Fan controller without Climatronic	9		

Validity

Manufacturer	Model	Type	EG-BE No./ABE
Audi	A3	8P	e1 * 2001/116 * 0217 * ...

VW Golf V and Golf Plus

Engine type	Engine model	Output in kW	Displacement in cm ³
CAXC	Gasoline TFSI	92	1390

Vehicle and engine types, equipment variants and national specifications not listed in these installation instructions have not been tested. However, installation according to these installation instructions may be possible.

The installation location of a digital timer and summer/winter switch should be confirmed with the end customer before installation.

Audi A3

Heater Unit/Installation Kit

Quantity	Description	Order No.:
1	Retail accessories with desired heater control	See price list
1	Installation kit for Audi A3 1.4 TFSI	1313621A

Heater unit recommended for the respective vehicle class:

Vehicle	Heater unit
Compact car	Thermo Top E
Mid-size car, station wagon	Thermo Top C
Full-size car, van, offroader	Thermo Top P

The selection of the heater unit is based on the passenger compartment size of the vehicle and the level of comfort required by the customer!



Foreword

These installation instructions apply to Audi A3 1.4 TFSI vehicles - for validity, see page 2 - from model year 2006 and later, assuming technical modifications to the vehicle do not affect installation, any liability claims excluded. Depending on the vehicle version and equipment, modifications may be necessary during installation with respect to these installation instructions.

However, the stipulations in the "installation instructions" and "operating and maintenance instructions" for the *Thermo Top C/P/E* must always be observed. The corresponding rules of technology and any information from the vehicle manufacturer should be observed during the installation work.

General Instructions

Installation should be carried out according to the general, standard rules of technology. Unless specified otherwise, fasten hoses, lines and wiring harnesses to original vehicle lines and wiring harnesses using cable ties.

Sharp edges should be fitted with edge protectors (split-open plastic hose).

Spray unfinished body areas, e.g. drilled holes, with anti-corrosion wax (Tectyl 100K, Order No. 111329).

Special Tools

- Torque wrench for 2.0 - 10 Nm
- Hose clamping pliers
- Unlocking tool

Explanatory Notes on Document

To provide you with a quick overview of the individual working steps, you will find an identification mark on the outside top right corner of the page in question.

Mechanical system

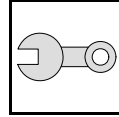

Electrical system

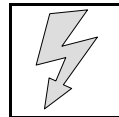

Water

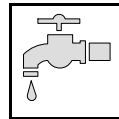

Fuel

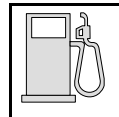

Exhaust gas

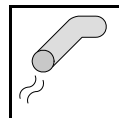

Combustion air

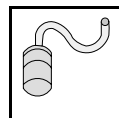

Special features are highlighted using the following symbols:



Specific risk of injury or fatal accidents.



Specific risk of damage to components.



Specific risk of fire or explosion.



Reference to general installation instructions of Webasto components or to the manufacturer's vehicle-specific documents.



Reference to a special technical feature.

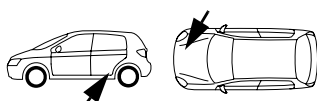

The arrow in the vehicle icon indicates the position on the vehicle and the viewing angle.

All dimensions are in mm!

Tightening torque of hose clamps = 2.0 + 0.5 Nm!

Tightening torque of Eجت screws, Eجت studs = 10 Nm!

Preliminary Work

WARNING!

- Open fuel tank cap, ventilate tank.
- Close the tank cap again.
- Depressurize the cooling system.
- Copy the factory number from the original type label to the duplicate type label.
- Remove years that do not apply from the duplicate label.
- Attach the duplicate label (type label) in the appropriate place.
- Disconnect the battery "earth" or "ground" connection.
- Remove battery.
- Remove the battery carrier.
- Remove the engine cover.
- Remove the left front wheel
- Remove the front section of the left front wheel well trim
- Remove the underride protection
- Remove the right-hand underbody trim
- Remove the rear bench seat
- Open the right-hand fuel sender service lid.
- Remove the footwell trim on the driver's side
- Remove the lower instrument panel trim on the driver's side
- Only with Climatronic: Remove the A/C control panel.

Remove page 25 "Operating Instructions for End Customer" and add to the vehicle operating instructions.

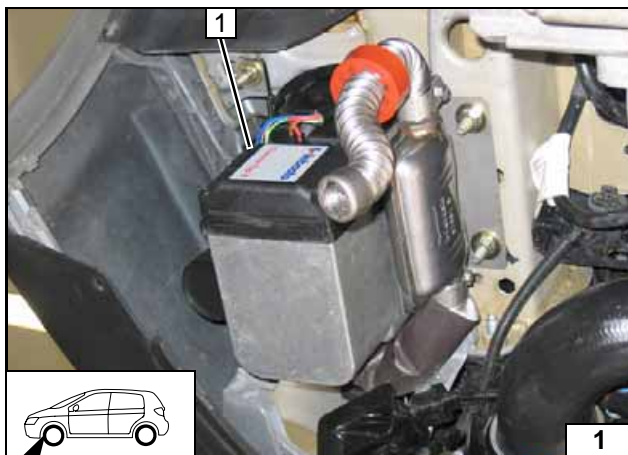

Heater unit installation location

- 1 Heater unit

Installation location



Electrical system

Wiring harness routing

Route excess lengths from wiring harness of heater unit 1 in cable duct below battery and secure with cable ties.

Wiring harness pass through in engine compartment

1 Original vehicle wiring harness pass through

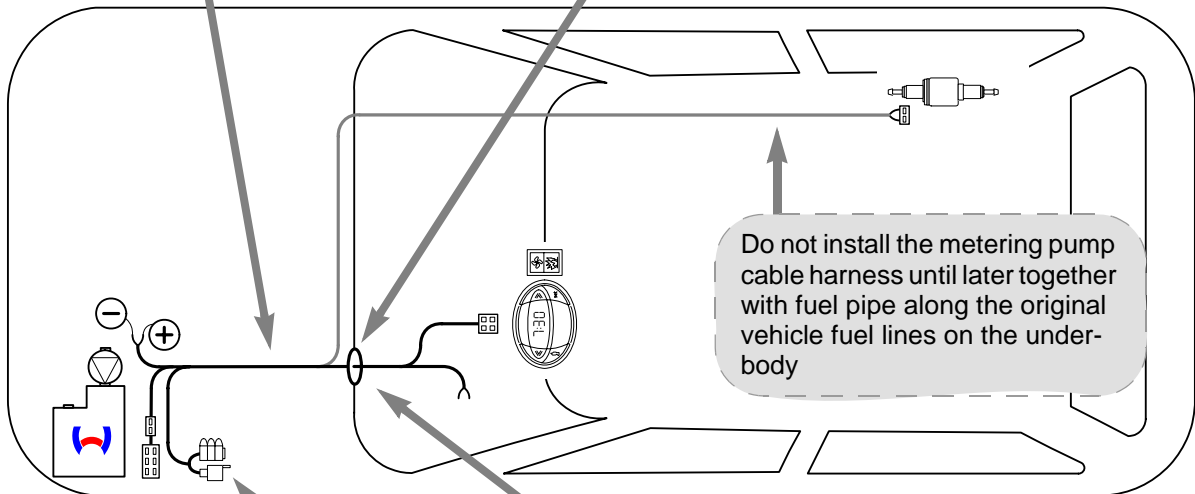
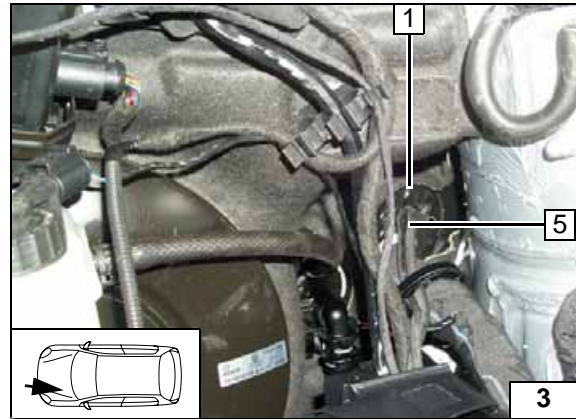
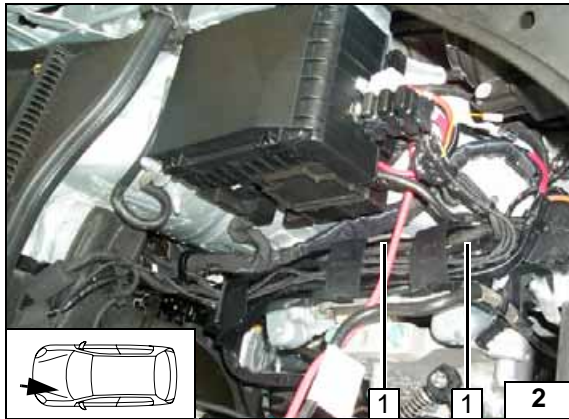

Wiring harness installation diagram

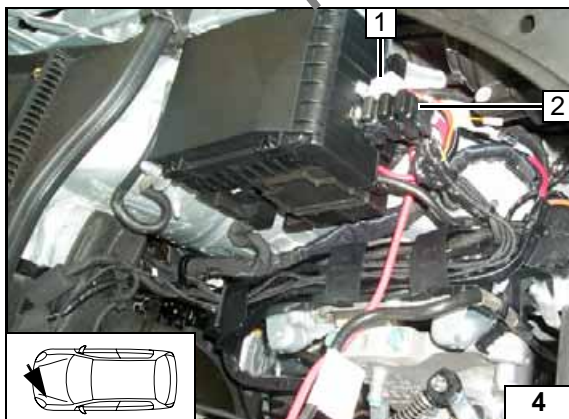

Fuse holder, relay K3

Description of installation for K3 relay 1 and fuse carrier 2 on Page 7

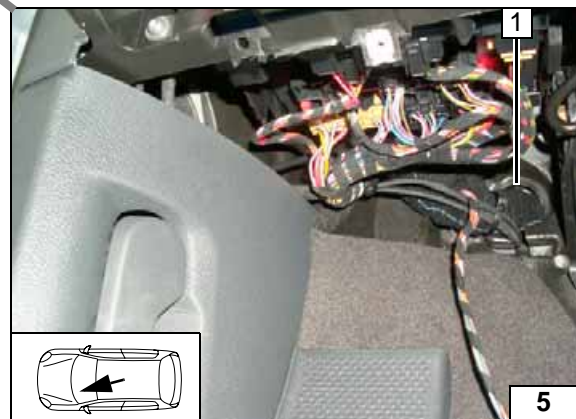

Wiring harness pass through of passenger compartment

1 Original vehicle wiring harness pass through

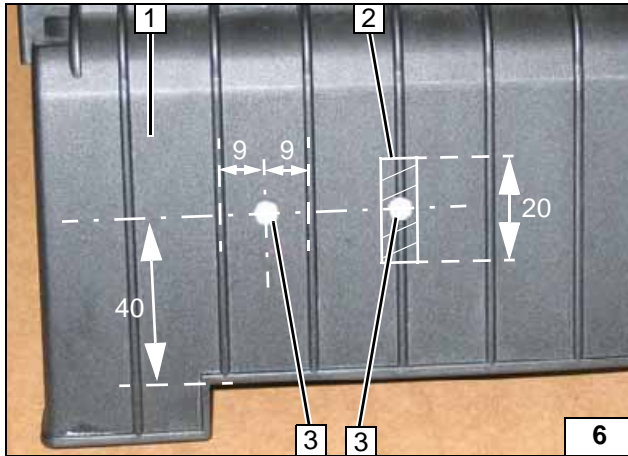
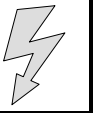

Fuse holder and relay K3

Countersink holes **3** from behind for M5 countersunk head screws.

- 1** Cover of fuse/relay carrier in engine compartment
- 2** Cut away bar in shaded area
- 3** 5.0 mm dia. hole [2x]



Holes for fuse holder and K3 relay

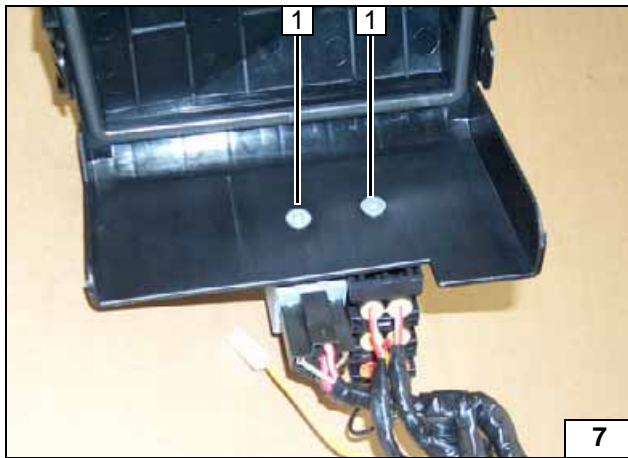

- 1** M5x12 countersunk head screw [2x]

Installing fuse holder and K3 relay

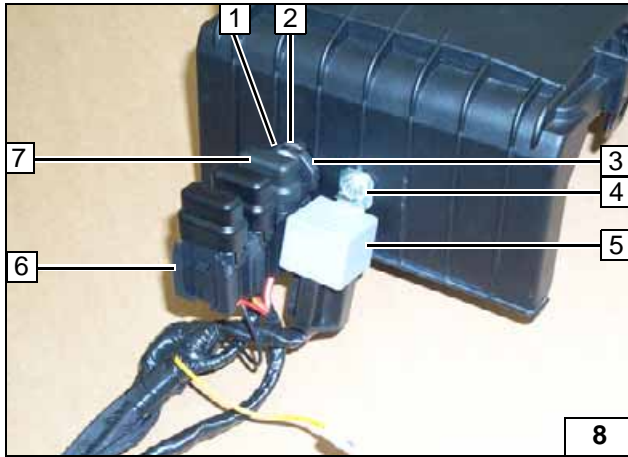

On vehicles with Climatronic, replace 25 A fuse F3 **7** with 5 A fuse provided.

- 1** M5 flanged nut
- 2** Large diameter washer (between cover and retaining plate)
- 3** Retaining plate
- 4** M5 flanged nut
- 5** Relay K3
- 6** Fuse holder



Installing fuse holder and K3 relay

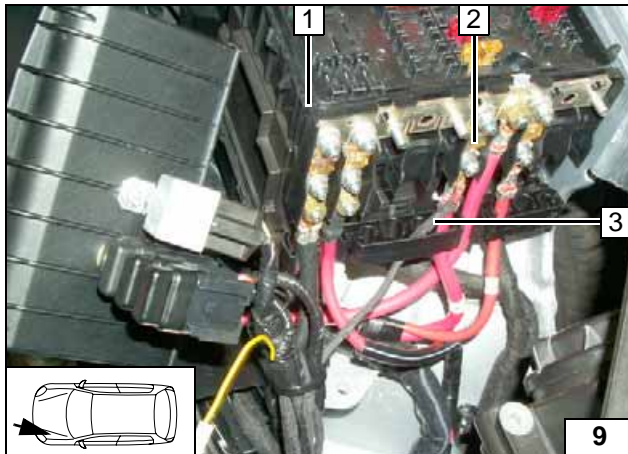

Route brown (br) ground wire to original vehicle ground support point below headlight and connect.

- 1** Fuse/relay carrier
- 2** Original main vehicle fuse
- 3** Red (rt) positive wire



Connecting positive and ground wire

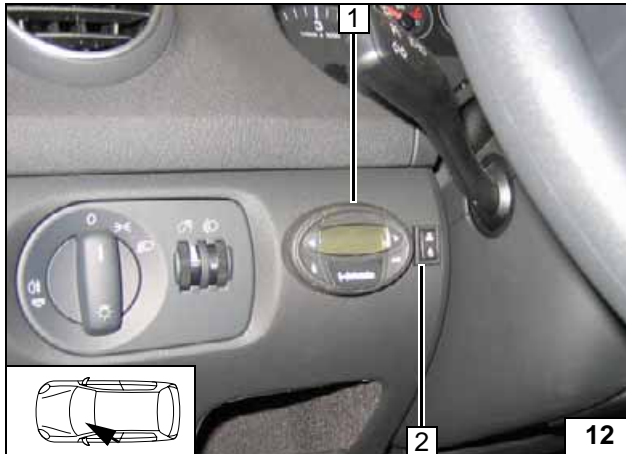
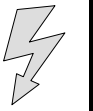

**Digital timer
Summer/winter switch option**

- 1 Digital timer
- 2 12 mm dia. hole, summer/winter switch



Installing digital timer

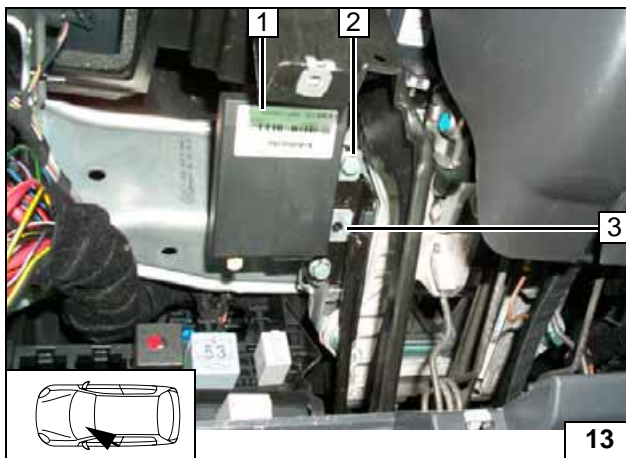

Remote option (Telestart)

If M6 screw 2 is not present, then use suitable M6 screw with spring lockwasher.
Drill out upper hole of bracket to 6.5 mm dia.

- 1 Receiver
- 2 M6 bolt in existing threaded hole
- 3 Bracket



Installing receiver

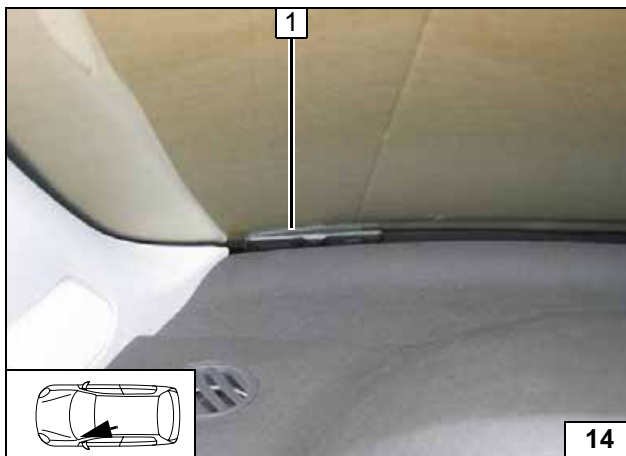

- 1 Antenna

Installing antenna

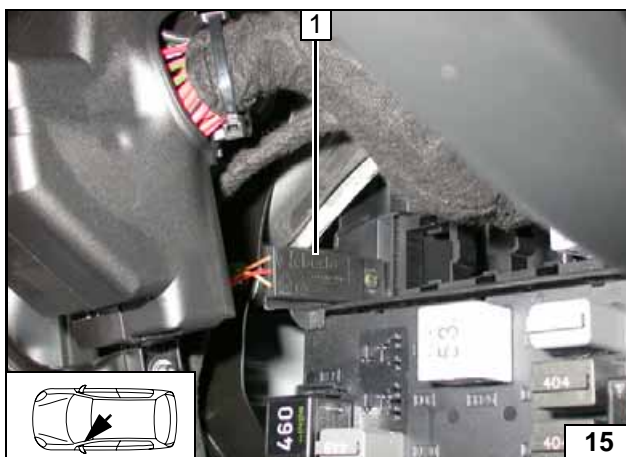

Temperature sensor HTM100

- 1 Fasten temperature sensor with adhesive tape



Installing temperature sensor

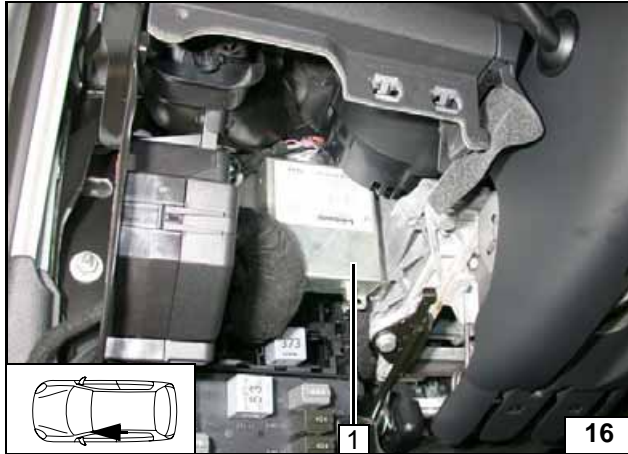

Remote option (Thermo Call)

1 Fasten receiver with adhesive tape



Installing receiver

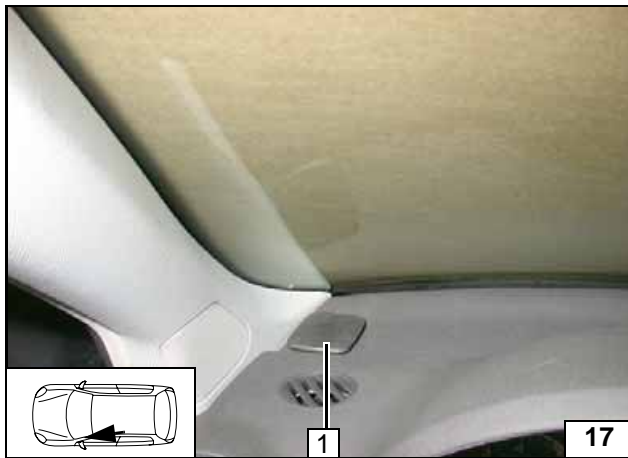

1 Antenna

Installing antenna

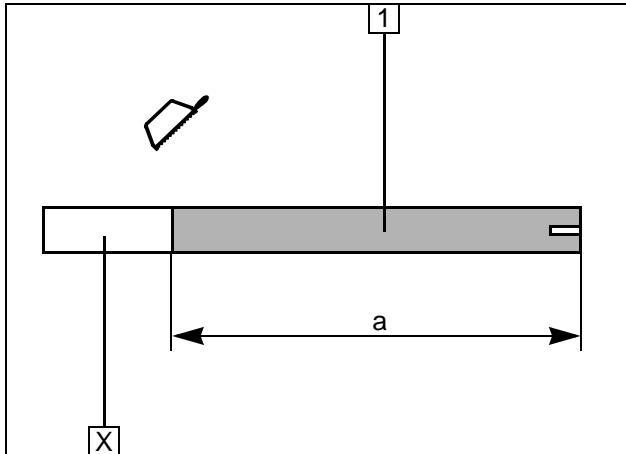
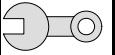

Preassembling heater unit

- 1 Combustion air pipe
a = 250

Discard section X

Cutting combustion air pipe to length

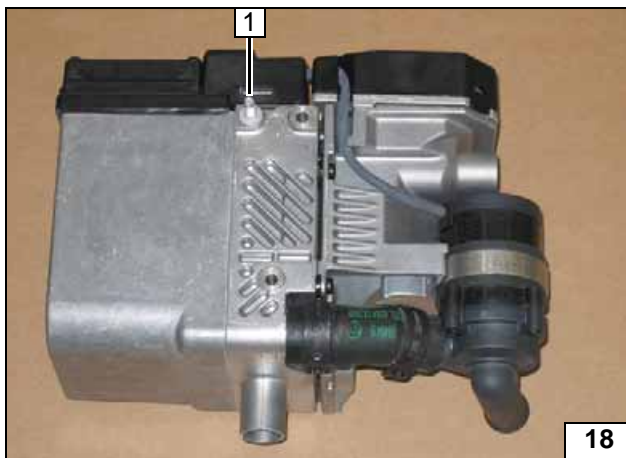

E-jot stud, tightening torque 10 Nm.

- 1 E-jot stud



Premounting heater unit

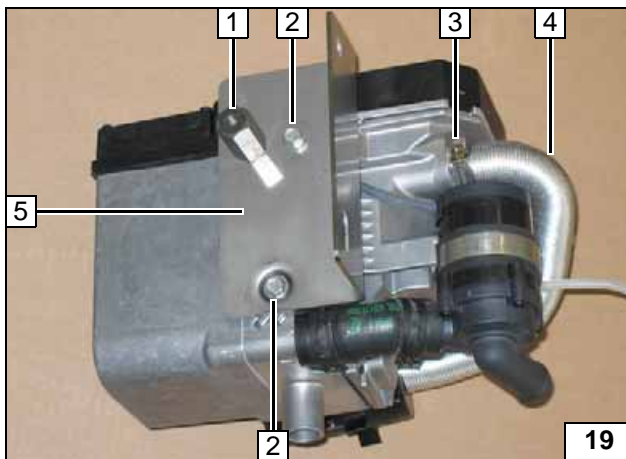

Insert one washer each between heater unit and bracket at positions 2

- 1 M6x30 spacer nut
- 2 Washer, E-jot screw [2x]
- 3 27 mm dia. clamp
- 4 Prepared combustion air pipe (slotted side on heater unit)
- 5 Bracket



Premounting heater unit

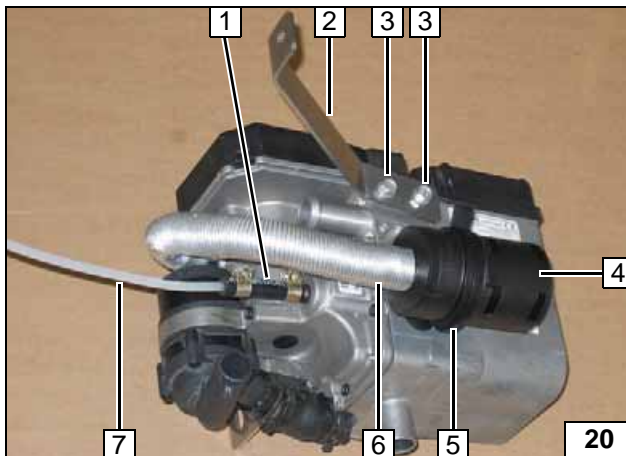

- 1 Hose section, 10 mm dia. clamp [2x]
- 2 Strut
- 3 E-jot screw [2x]
- 4 Combustion-air intake muffler
- 5 Retaining clip in hole of heater unit
- 6 Combustion air pipe
- 7 Fuel line

Premounting heater unit

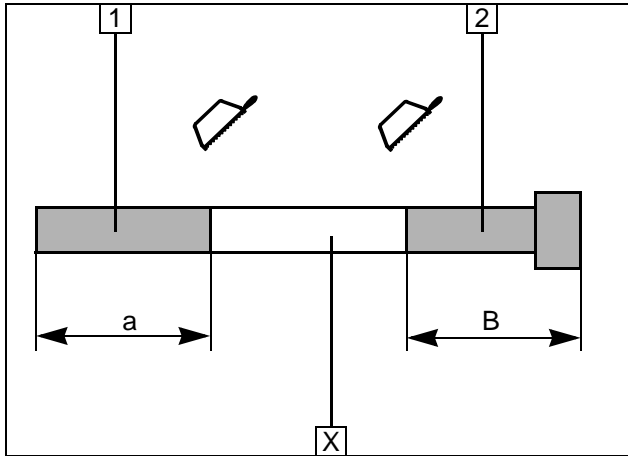
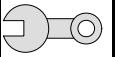

- 1 Exhaust pipe
a = 190
- 2 Exhaust end section
b = 240

Discard section X



**Cutting ex-
haust pipe
to length**

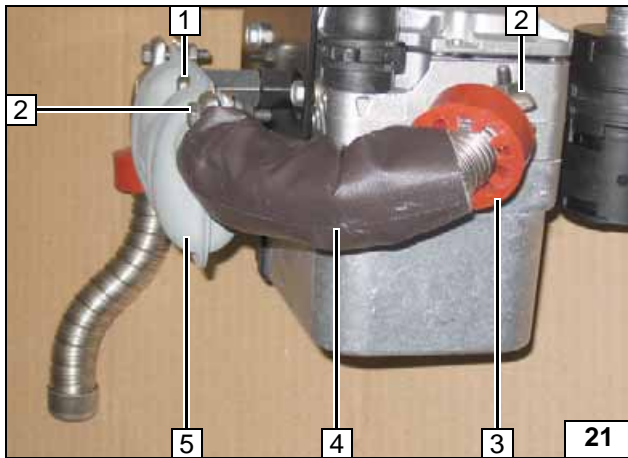

- 1 M6x16 bolt, spring lockwasher
- 2 Hose clamp [2x]
- 3 Red (rt) rubber isolator, without groove
- 4 Exhaust pipe with insulation
- 5 Muffler

**Premount-
ing ex-
haust
system**

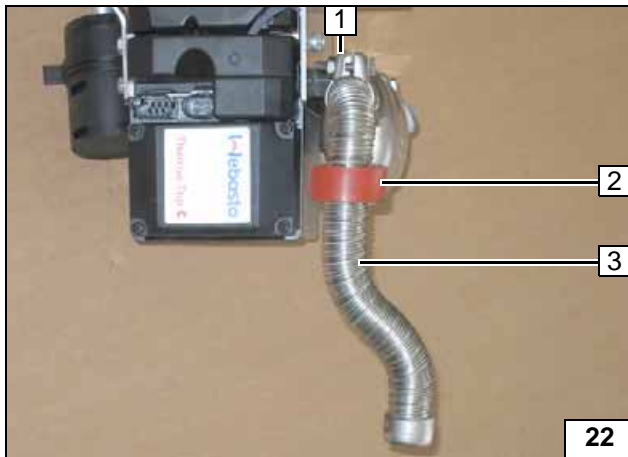

- 1 Hose clamp
- 2 Red (rt) rubber isolator, without groove
- 3 Exhaust end section

**Premount-
ing ex-
haust
system**

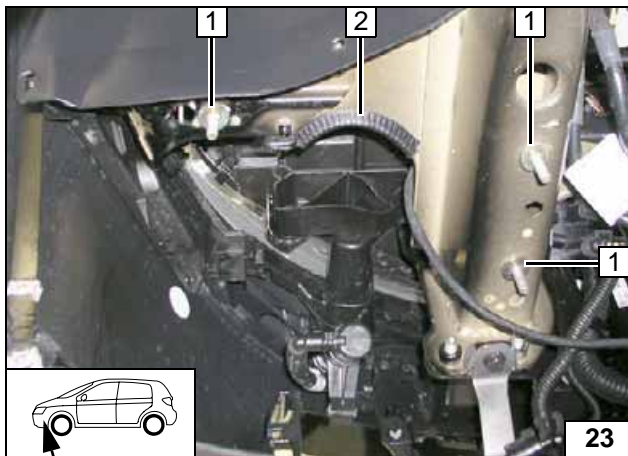

Preparing installation location

Secure large diameter washer against falling with putty etc.

- 1 Large diameter washer on original vehicle stud bolt [3x]
- 2 Edge protection section



**Preparing installa-
tion loca-
tion**

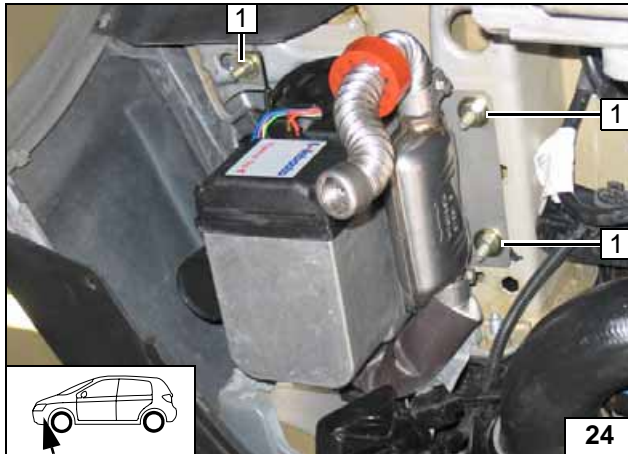
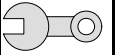

Installing heater unit

- 1 Large diameter washer, flanged nut M8 [3x]



Installing heater unit

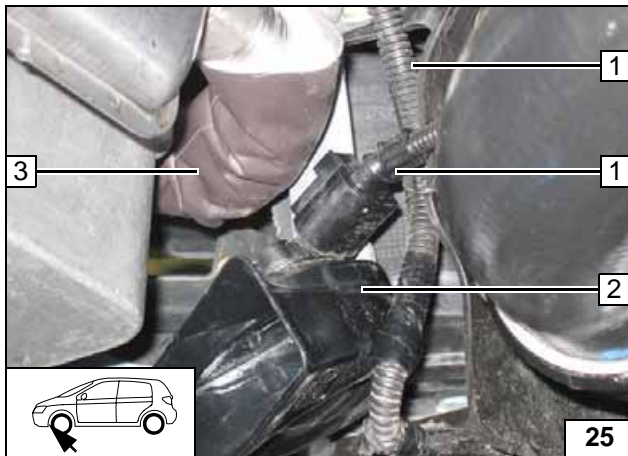

Ensure freedom of movement of exhaust system relative to original vehicle component and lines.

- 1 Original vehicle wiring harnesses (secured with cable ties)
- 2 Horn
- 3 Exhaust pipe



Aligning exhaust system

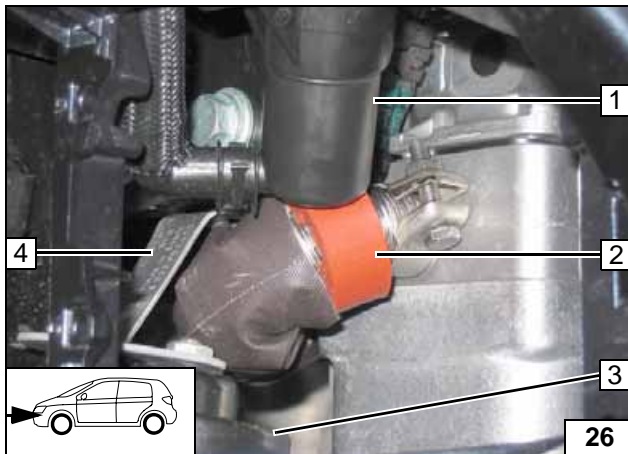

Ensure freedom of movement of exhaust system relative to original vehicle component and lines.
Position rubber isolator 2.

- 1 Headlight washer system
- 3 Horn
- 4 Horn bracket



Aligning exhaust system

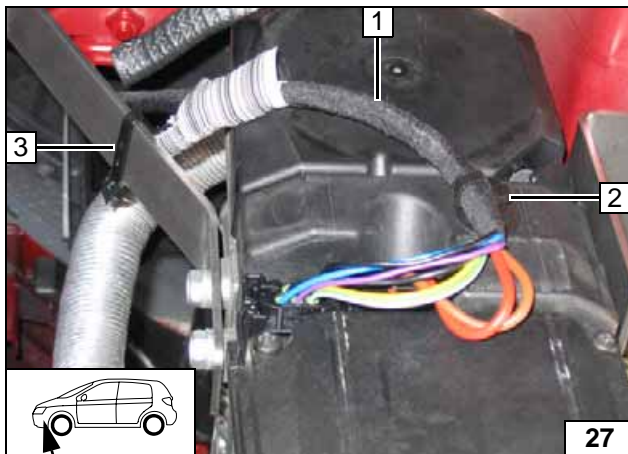

Watch routing of wiring harness. Danger of rubbing!

- 1 Wiring harness of heater unit
- 2 Clip cable tie in pre-perforated hole of heater unit cover
- 3 Cable tie



Mounting and routing wiring harness



Fuel Connection

CAUTION!

Open the vehicle's fuel tank cap, ventilate the tank and then re-close the tank lock.

Catch any fuel running off with an appropriate container.

Install fuel line and metering-pump wiring harness so that they are protected against stone impact. Unless specified otherwise, always fasten using cable ties. Mount the fuel line and wiring harness with rub protection on sharp edges.

WARNING!

The fuel line and wiring harness are routed to the metering pump in as shown in the wiring harness routing diagram.

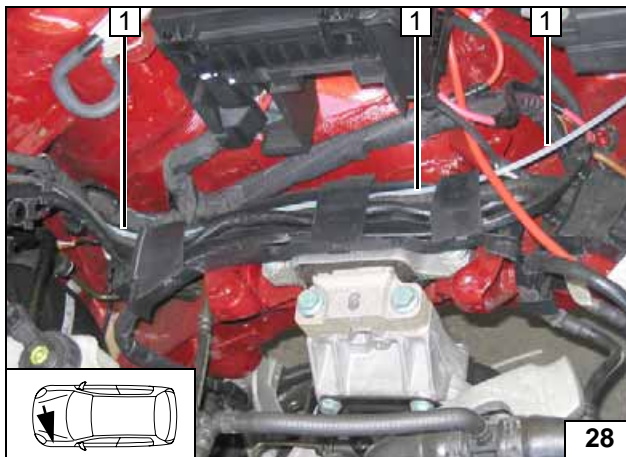

1 Fuel line

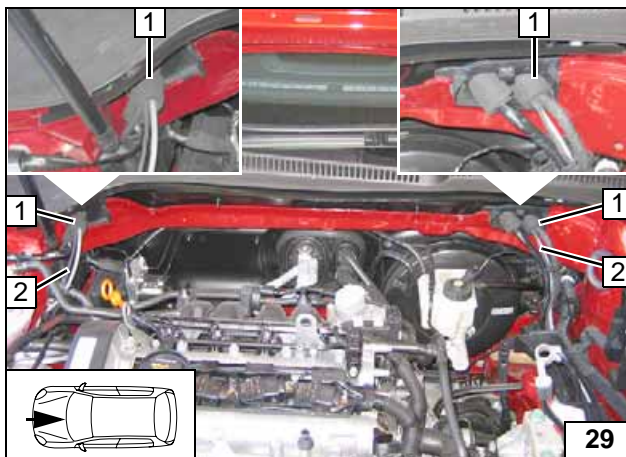

Route Mecanyl line and wiring harness of metering pump **2** in coolant reservoir to right and fasten on original vehicle lines with cable ties. Pay particular attention to freedom of movement of wiper linkage. Route Mecanyl line and wiring harness of metering pump to underbody in line duct.

2 Existing pass through [2x]

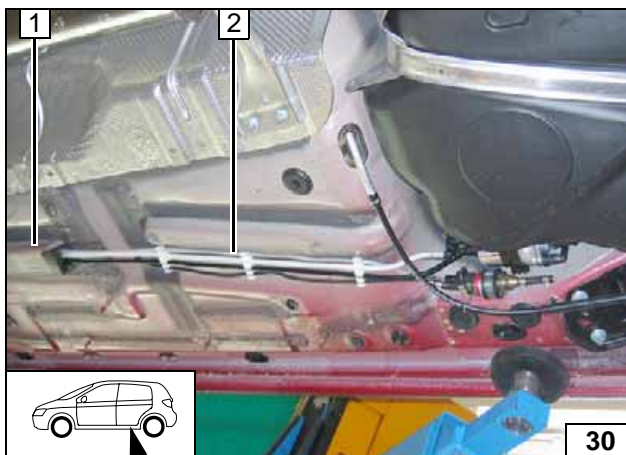

Route fuel line and wiring harness of metering pump along original vehicle fuel lines **2** to fuel tank.

1 Line duct



Routing to firewall



Routing in coolant reservoir



Routing fuel line and wiring harness of metering pump

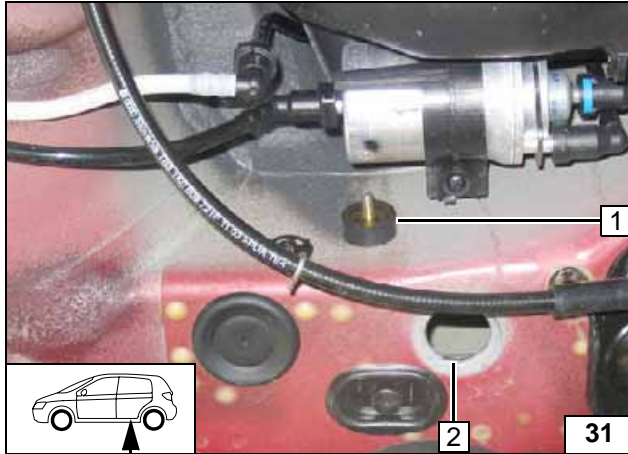

- 1 Silent block, large diameter washer, M6 flanged nut
- 2 Remove sealing plug

Installing silent block

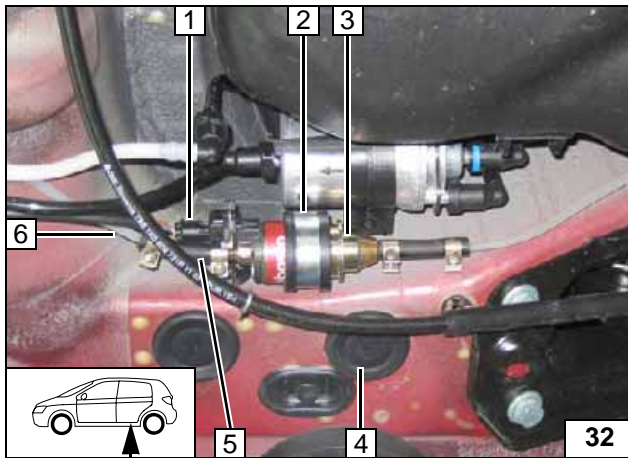

- 1 Wiring harness of metering pump, connector mounted
- 2 Secure rubber-coated p-clamp on silent block with flanged nut
- 3 Metering pump
- 4 Plug remounted
- 5 Hose section, 10 mm dia. clamp [2x]
- 6 Fuel line



Mounting metering pump and connecting pressure side

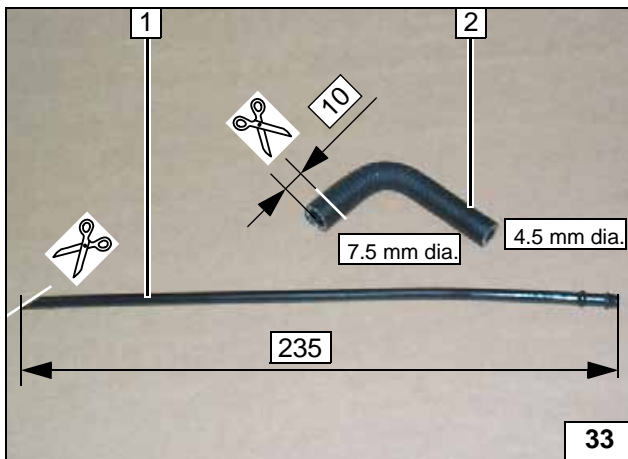

- 1 Standpipe
- 2 Molded hose

Cutting standpipe and molded hose to length

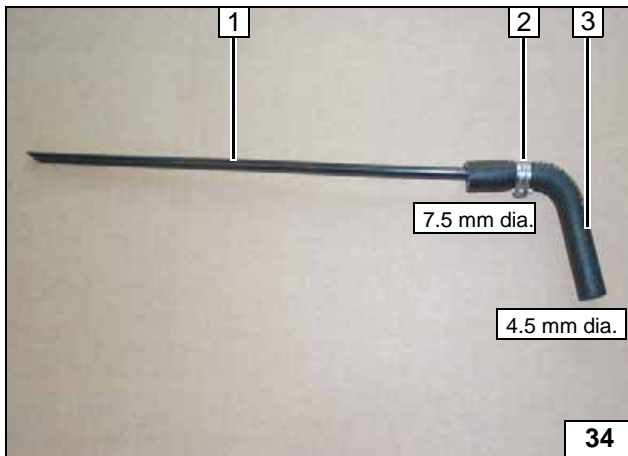

10 mm dia. Caillau clamp 2 in center between beads on end of standpipe.

- 1 Standpipe
- 3 Molded hose



Pre-mounting standpipe and molded hose

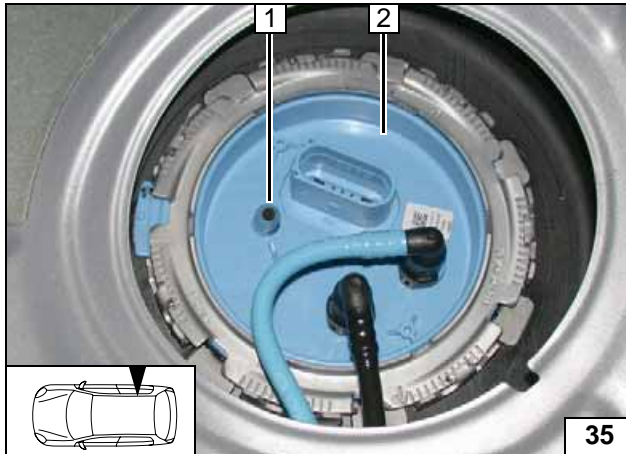
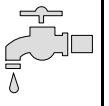

- 1 Tip of blind plug shortened by 3 mm
- 2 Fuel sender



Cutting off blind plug

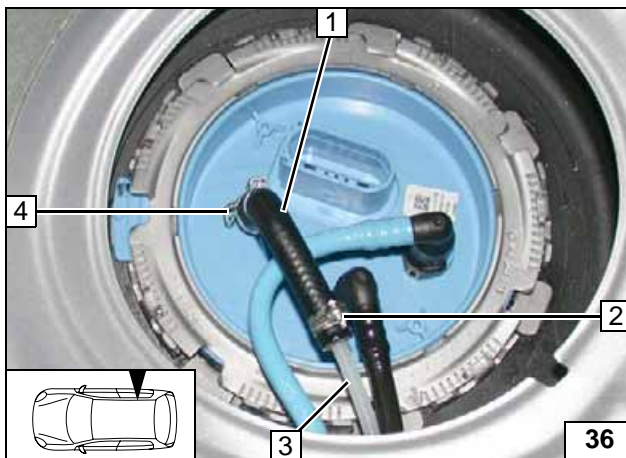

Should the standpipe be slightly curved on delivery, then it must be aligned so that the end points toward the rear right. Otherwise there is a danger of the fuel gauge being impaired.

- 1 Preassembled molded hose with standpipe
- 2 10 mm dia. clamp
- 3 Fuel line
- 4 13.5 mm dia. clamp



**Connec-
tion to fuel-
tank send-
ing unit**

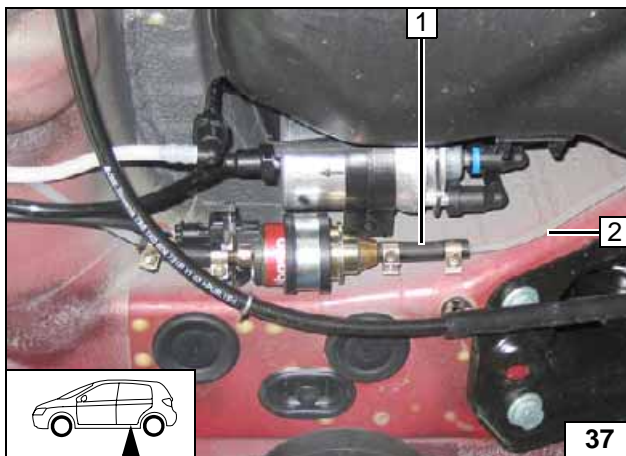

- 1 Hose section, 10 mm dia. clamp [2x]
- 2 Fuel line from fuel-tank sending unit



**Connect-
ing intake
side of me-
tering
pump**

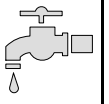

Coolant







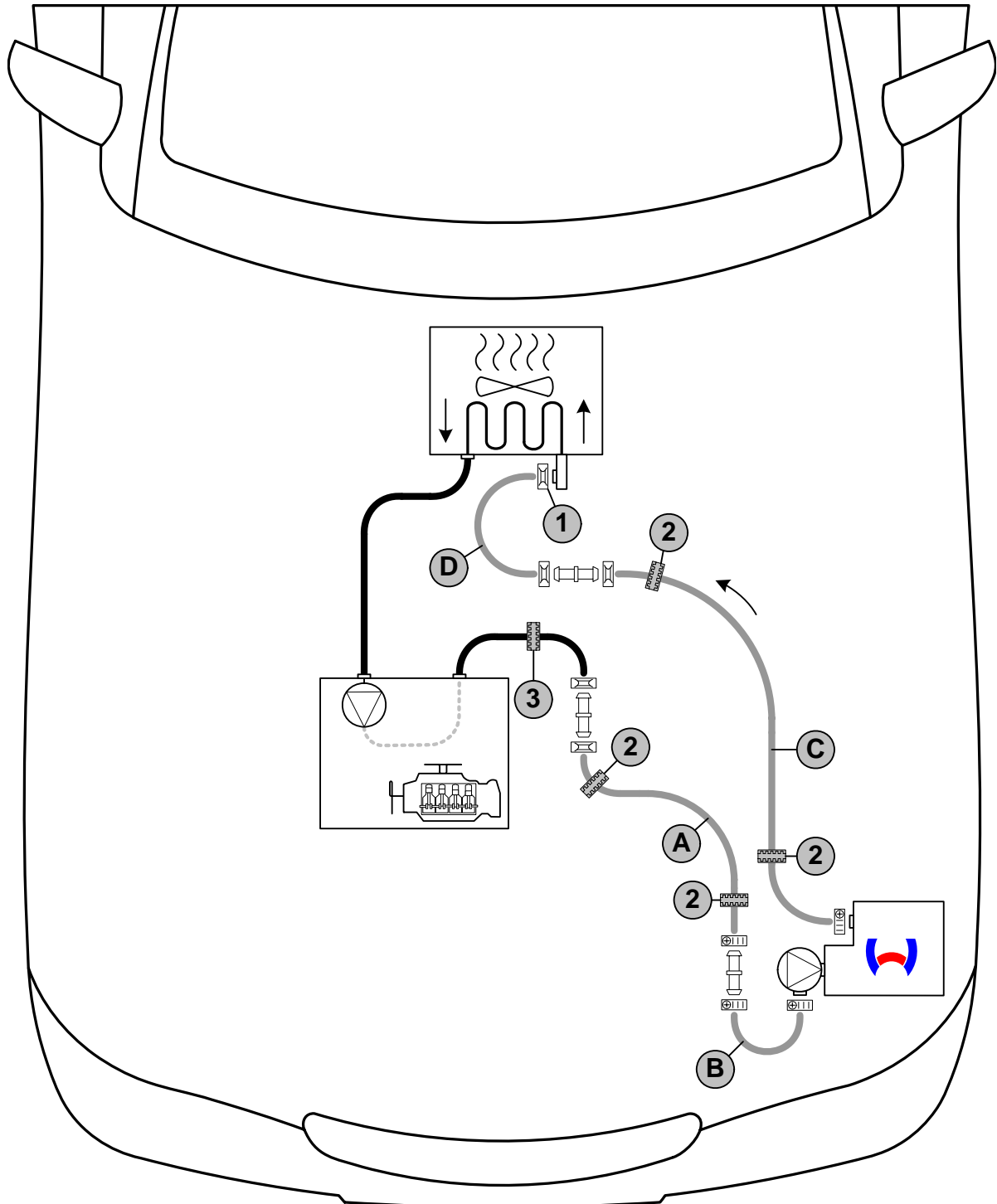

WARNING!

Any coolant running off should be collected using an appropriate container. Install hoses so that they are kink-free. Unless specified otherwise, always fasten using cable ties. Position clamps so that no other hose can be damaged! When installing the coolant hose, the heater unit must be filled with coolant.

The connection should be "inline" based on the following diagram:



Coolant routing diagram

All spring clips without a specific designation  = 27 mm dia. **1** = Original vehicle spring clip  .
 All hose clamps  = 20-27 mm dia.! All connecting pipes  = 20x20 dia..
2 = Black (sw) 20 mm dia. rubber isolator  [4x]. **3** = Black (sw) 18 mm dia. rubber isolator .



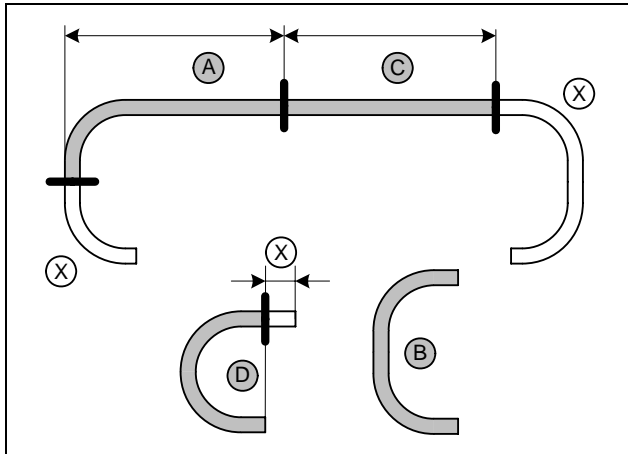
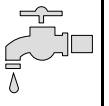

a = 970
c = 1180

Hose **B** = 180° molded hose
Shorten hose **D** = 180° molded hose
Discard section **X**



Cutting coolant hoses to length

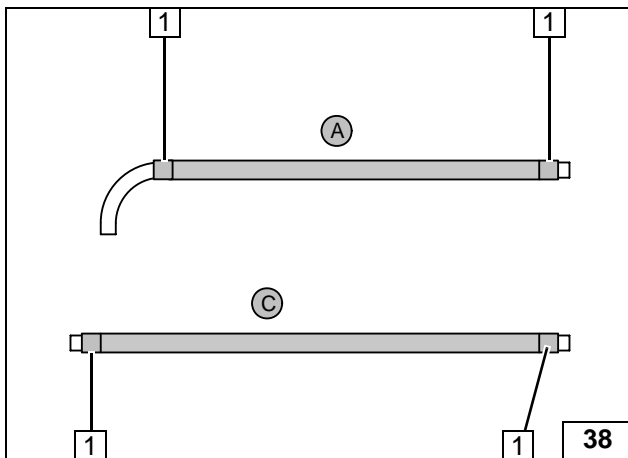

Push braided protection hoses onto hose **A** and **C**, cut to length and shrink.

1 Heat shrink plastic tubing [4x]



Preparing coolant hoses

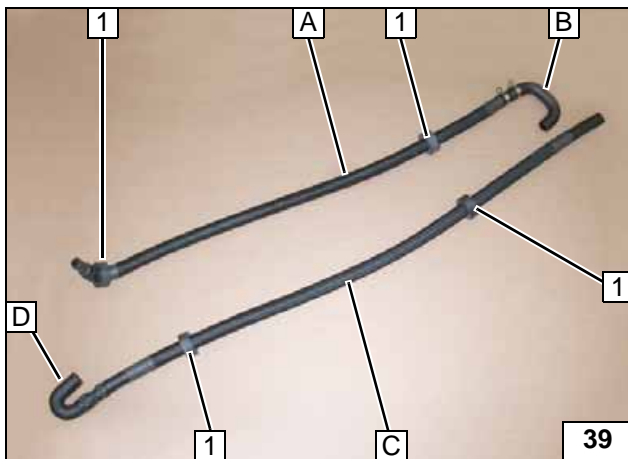

Slide black (sw) rubber isolator [4x] onto hose **A** and **C**.



Premounting coolant hoses

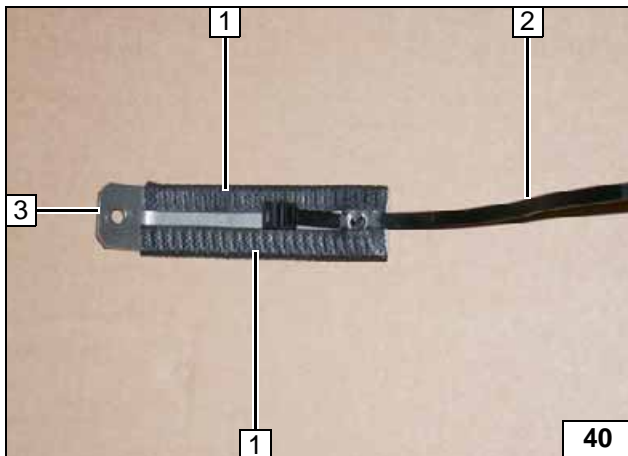

Cut edge protection in half **1** [2x] and push onto bracket of coolant hoses **3**

2 Clip-type cable tie in existing hole



Preparing bracket for coolant hoses

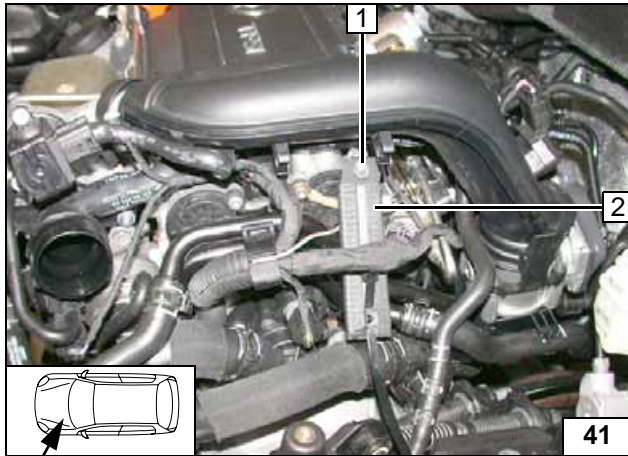
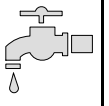

Insert M8 nut as between engine and bracket of coolant hose 2 as spacer.

1 M6x20 bolt, M8 nut in existing hole



Installing bracket for coolant hoses

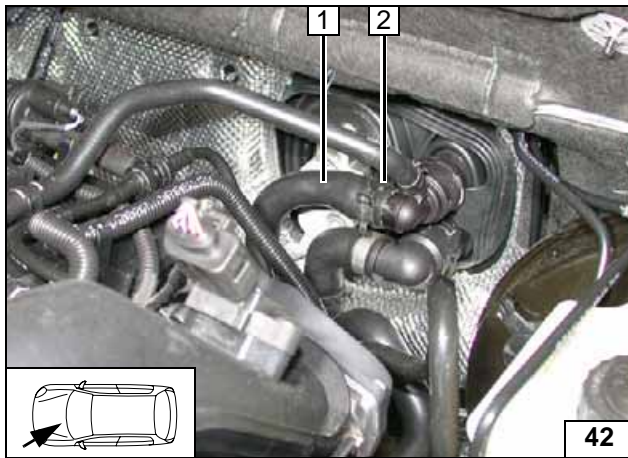

Disconnect hose to engine outlet/heat exchanger inlet 1 at coupling on heater exchanger inlet. Spring clip 2 will be reused.



Cutting point

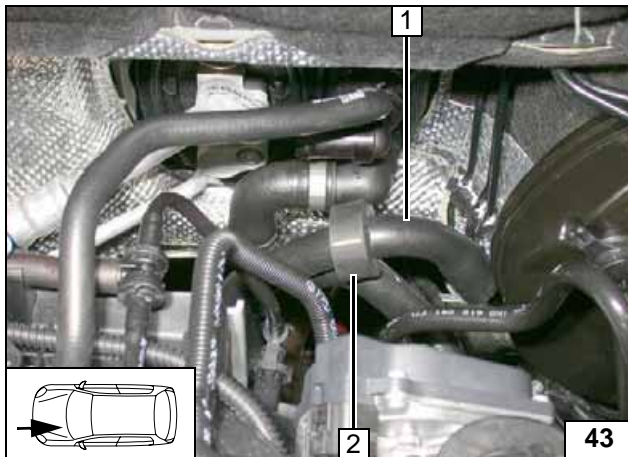

1 Engine-outlet hose section
2 Black (sw) 18 mm dia. rubber isolator

Pushing on rubber isolator

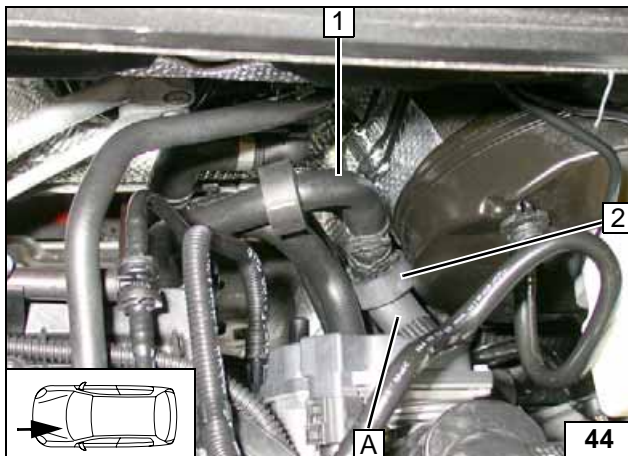

Position black (sw) rubber isolator 2.

1 Hose of engine outlet



Connecting engine outlet

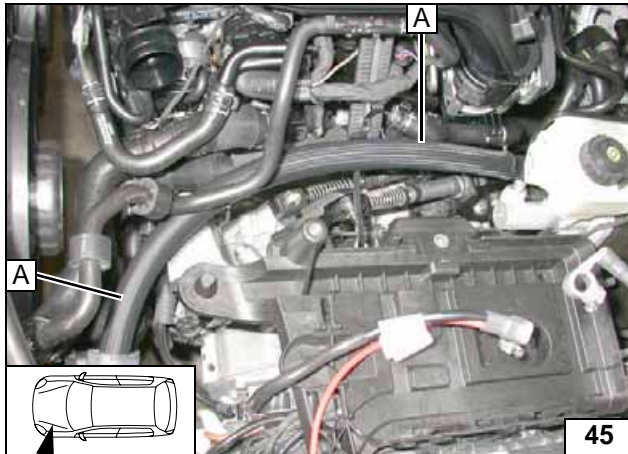

Routing in engine compartment

1 Spacer bracket

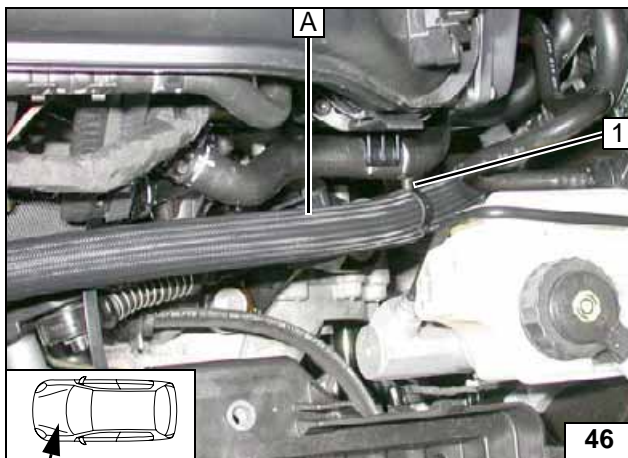

Installing spacer bracket

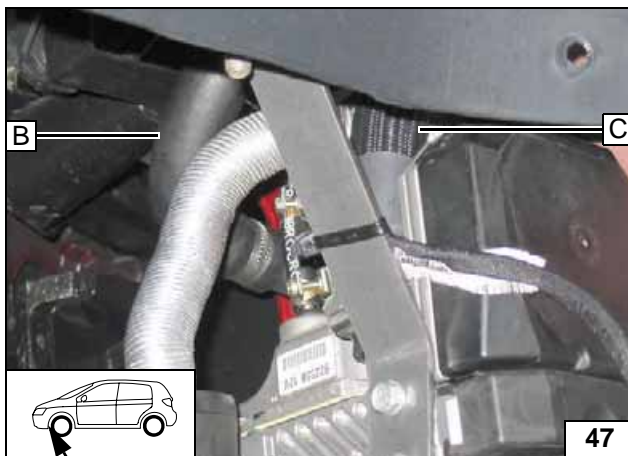

Connection to heater unit

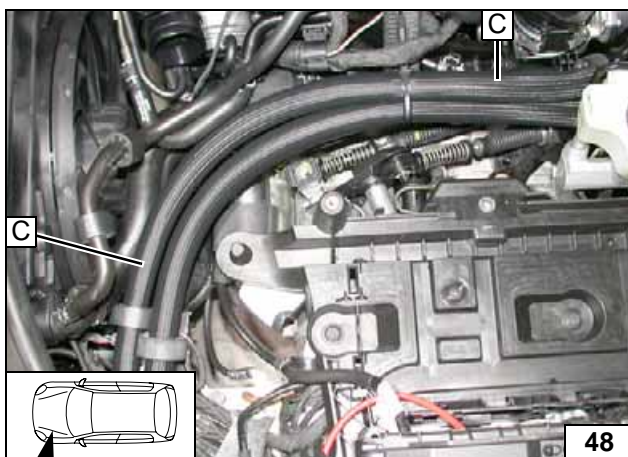

Routing in engine compartment

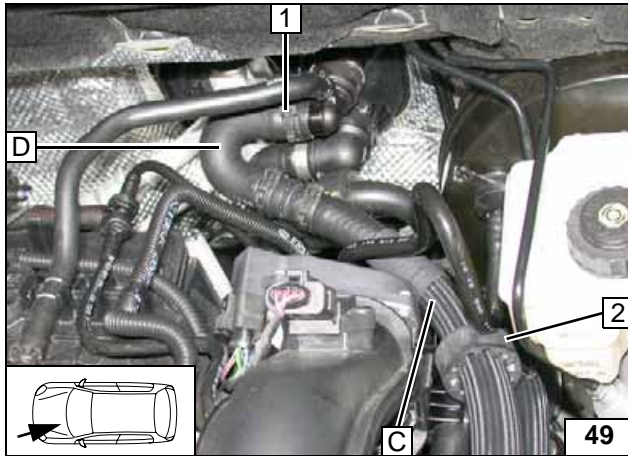
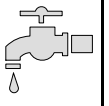

Ensure sufficient distance to neighboring components.

- 1 Original vehicle spring clip
- 2 Position black (sw) rubber isolator



**Connect-
ing heat
exchanger
inlet**

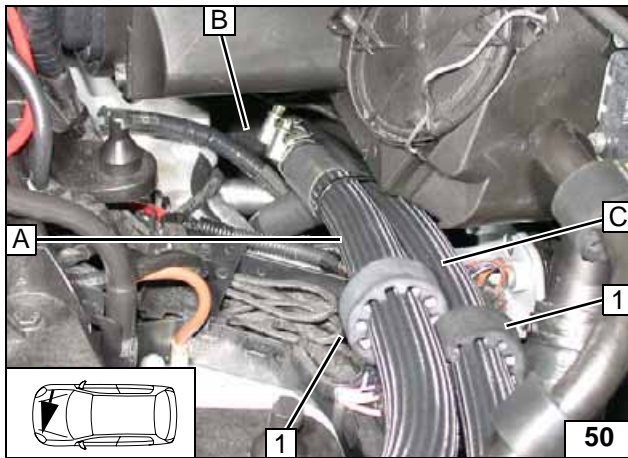

Position black (sw) rubber isolator 1 [2x] on original vehicle connector.



**Aligning
hoses**

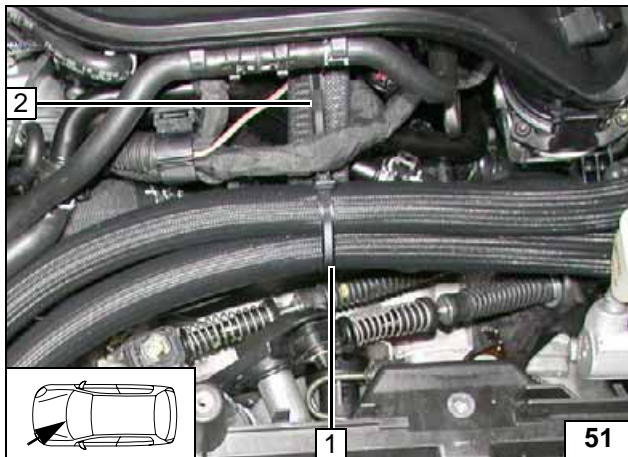

- 1 Hole cable tie
- 2 Strut

**Fastening
hoses**

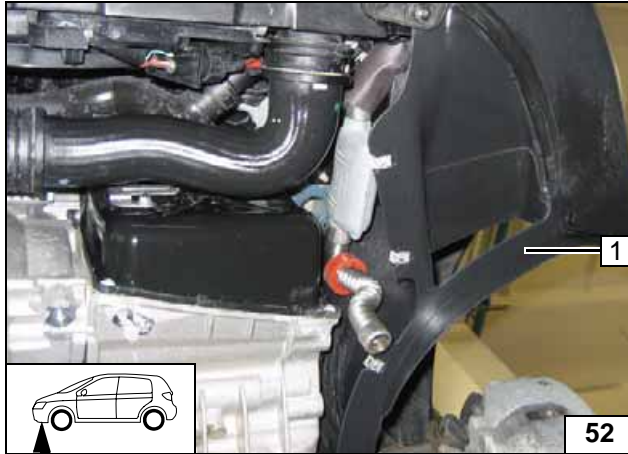
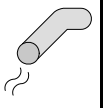

Exhaust gas

Align exhaust end section and rubber isolator. Ensure sufficient spacing of exhaust end section to transmission and to wheel well trim. (Picture shows vehicle with direct shift transmission)

1 Wheel well trim



Installing wheel well trim

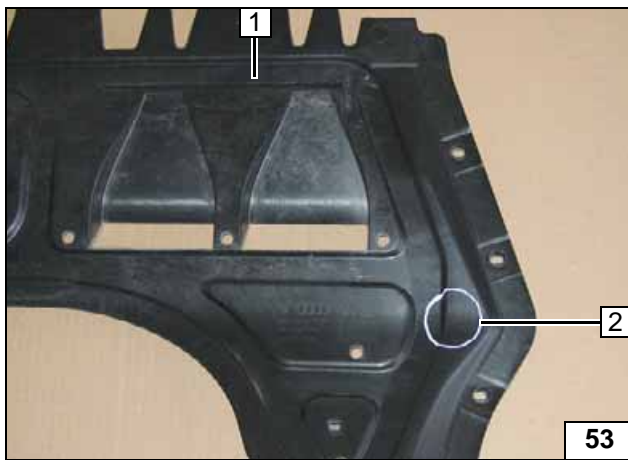

1 Underride protection
2 42 mm dia. hole

Hole in underride protection

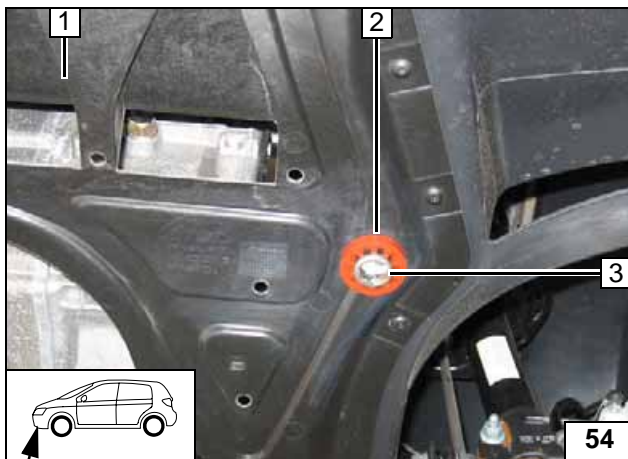

Align exhaust end section **3** flush on red rubber isolator **2**.

1 Underride protection



Mounting rubber isolator

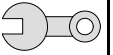

Final Work

WARNING!

Reassemble the disassembled components in reverse order.

Check all hoses, clamps and all electrical connections for firm seating.

Secure all loose cables using cable ties.

Only use manufacturer-approved coolant.

Spray heater unit components with anti-corrosion wax (Tectyl 100K, Order No. 111 329).

- Connect the battery
- Fill and bleed the coolant circuit according to the vehicle manufacturer's specifications.
- Set the digital timer.
- Make setting on A/C control panel according to the "Operating Instructions for End Customer".
- Check the proper operation of the additional heater, see the operating instructions/installation instructions.
- Attach the "Switch off additional heater before refueling" sticker to the left-hand B-pillar.



Adjust the sensitivity of the passenger compartment monitoring

WARNING!

This can only be carried out at an authorized workshop! Observe the applicable repair manual of the respective vehicle.

- Connect the VAS tester.
- Open Item 46 (Central Module of Comfort System)
- Go to Item 10 (Adjustment)
- Follow the request for the code entry and enter the code 15
- Reduce the sensitivity of the passenger compartment monitoring to 50 %
- Save this setting
- The adjustment of the sensitivity of the passenger compartment monitoring is completed.



Webasto AG
Postfach 80 - 82132 Stockdorf
Hotline 01805 / 932278 - Hotfax 0395 / 5592-353
<http://www.webasto.de>

Operating Instructions for End Customer



Please remove page and add to the vehicle operating instructions.

Note:

We recommend matching the heating time to the driving time.

Heating time = driving time

Example:

For a driving time of approx. 20 min. (in one direction), we recommend not exceeding a switch-on time of 20 min.

If the summer/winter switch option has been installed, this must be switched in accordance with the time of year. The heater unit will then only switch on the vehicle fan to ventilate the vehicle interior in the position Winter heat and in the position Summer .



Before parking the vehicle, make the following settings:

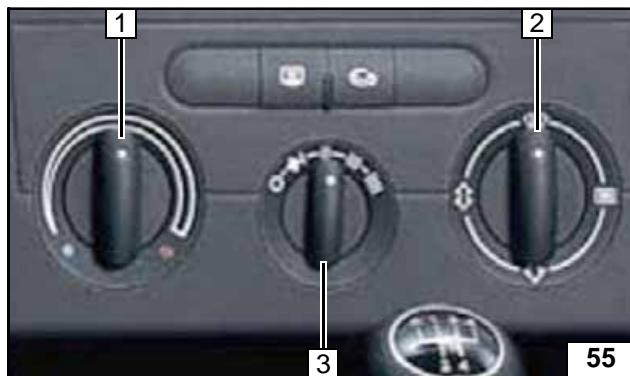

- 1 Set temperature to "max."
- 2 Air outlet to windshield
- 3 Set fan to level "1", or possibly "2"

For vehicle without Climatronic



- 1 Set temperature on both sides to "HI".

For vehicle with Climatronic