

Water heater



Feel the drive

Thermo Top E additional heating system

Thermo Top - Z/C additional heating system

Approval code ~~~ S 316 / ~~~ S 292

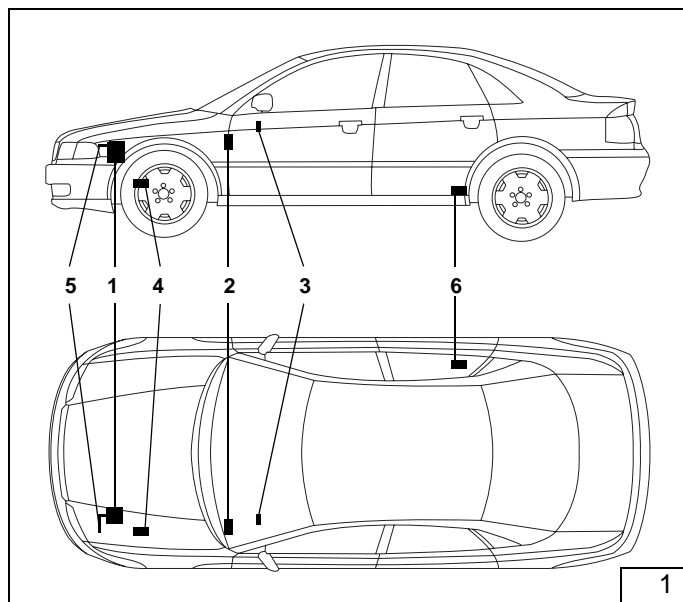

Legend for Figure 1

- 1 Thermo Top Z/C-B or E-B heater
- 2 Blade-type fuse holder and blower relay
- 3 Digital timer
- 4 Exhaust silencer
- 5 Combustion air intake line
- 6 Dosing pump

Special tools

- Clamping claw
- Torque wrench for 2.0 – 10 Nm

Special Audi tools

- Clamping pliers V.A.G. 1275
- Tool to open the locking ring on the fuel tank fittings

Table of contents

Audi A4	1	Integration in the fuel system	17
Heater / Installation kit	2	Exhaust system	22
Validity	2	Combustion air intake line	23
Foreword	2	Concluding work	24
Special tools	3	Operating instructions for the end customer	25
General information	3		
Preparations	3		
Installation site for the heater	4		
Blade-type fuse holder and blower relay	4		
Digital timer and optional summer/winter switch	9		
To install the heater	10		
Integration in the water system	13		

Installation instructions

Audi A4

1.6l and 2.0l petrol

Left-hand drive models only

All equipment versions

Tested vehicles, see page 2

The vehicle types, engine types and equipment versions not listed in these installation instructions have not been tested.

It may nevertheless be possible to install the system using these installation instructions. Compliance with the licensing regulations set out on page 2 is essential.

NOTE:

An application for the general model licence (ABG) has been submitted to the German Federal Department of Transport but the licence has not yet been issued.

Heater / Installation kit

Quantity	Description	Order No.
1	Water heater <i>Thermo Top E - B</i>	668 90A
	or	
1	Water heater <i>Tele Thermo Top E - B</i>	670 84A
	or	
1	Water heater <i>Thermo Top Z/C - B</i>	906 04A
	or	
1	Water heater <i>Tele Thermo Top Z/C - B</i>	670 83A
Also required:		
1	Audi A4 installation kit <i>Thermo Top Z/C/E-B</i>	13 007 61A

Validity

Manufacturer	Type	Trade name	EC licence No.
Audi AG		Audi A4	e1*98/14*0151*..

Engine code	Engine type	Output in kW	Displacement in cc
ALZ	Petrol	75	1595
ALT	Petrol	96	1984

Foreword

These non-binding installation instructions apply to the Audi A4 1.6l and 2.0l petrol version (see cover sheet for validity) model year 2001 and later, unless technical modifications on the car influence the installation, excluding all liability claims. Depending on the version and equipment in the car, changes may be required to the installation work set out in these installation instructions. In any event, however, the directives in the "installation manual" and "operating manual" **Thermo Top Z/C/E** must be followed. The appropriate engineering conventions must be observed for the installation work.

IMPORTANT:

The licensing regulations must be observed.

In the Federal Republic of Germany, retrofitting the Thermo Top Z/C additional heating systems using these installation instructions must be approved since the general operating licence (ABG) does not feature a special supplement. The system must be installed as set out in the installation manual. It must be tested

- a) in the type test of the cars pursuant to §20 of the German Road Traffic Act,
- b) in the individual test pursuant to §21 of the German Road Traffic Act or
- c) in the assessment pursuant to §19 of the German Road Traffic act by an officially approved expert or tester for the motor trade, a motor vehicle expert or employees as described in section 4 of Appendix 8b to the German Road Traffic Act

and in case c) this must be certified, quoting the vehicle manufacturer, model and vehicle identification number on the approval confirmation. The validity of the model licence depends on this.

General information

- Bare body parts, for example around drilled holes, must be treated with anti-corrosive coating.
- Secure hoses, cables and wiring harnesses with cable ties and fit protective hoses around them at chafing points
- Fit edge protectors (opened fuel hose) to sharp edges

Preparations

- Remove the inapplicable year number from the duplicate plate
- Fit the duplicate plate (model plate) in a suitable position where it is visible

Exterior

- Open the filler cap, release the pressure from the fuel tank system and close the filler cap again
- Remove the underride guard
- Remove the underbody guard on the right in full
- Remove the bumper
- Remove both front wheel arch trims
- Remove the left headlight

Under-bonnet compartment

- Remove the engine cover

IMPORTANT:

Disconnect the battery

- Remove the battery
- Open the radiator cap and release the pressure
- Close the radiator cap again
- Release the coolant expansion tank and move it to one side
- Remove the wiper arms
- Remove the radiator tank cover
- Remove the top windscreen washer tank (2-piece)
- Remove the air filter

Interior

- Remove the rear seat bench
- Remove the bottom dashboard trim on the driver side
- Remove both sills / sill covers on the left
- Remove the service flap from the tank fittings
- Release the central electrical system
- Remove the air-conditioning control module

Installation site for the heater

The heater (2/1) is to be installed at the front left between the wheel arch and the bumper as shown in Figure 2. It is installed vertically and perpendicular to the vehicle's length.

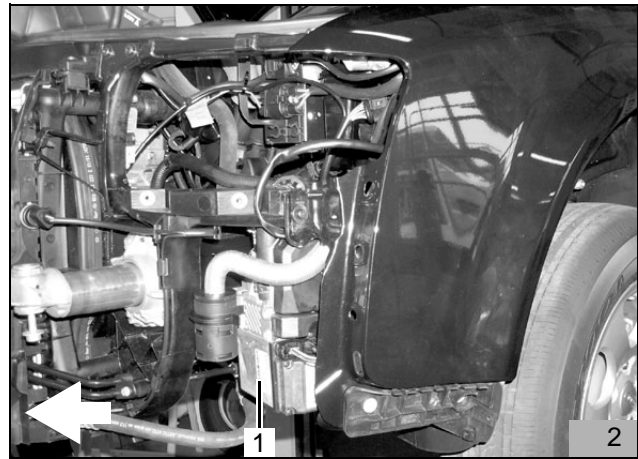

Blade-type fuse holder and blower relay

To prepare the wiring harness

- Cut the br cable (3/6; 4/6) 1.5 mm² from the earth post to the dosing pump
- Cut the bl cable (3/7,8; 4/3,4,5) from the heater to the dosing pump
- Cut the br cable (3/9; 4/3) 2.5 mm² from the earth post to the heater
- Cut the rd cable (3/2; 4/1) 4.0 mm² from the fuse holder to the heater
- Cut the gn/wt cable (3/1; 4/2) 0.75 from blower relay K3 to the heater
- Cut the rd cable (3/3; 4/10) 0.75 mm² from the fuse holder to the digital timer
- Cut the br cable (3/5; 4/9) 0.75 mm² from the earth post to the digital timer at plug X9
- Cut the br cable (3/4; 4/8) 0.75 mm² from the earth post in the digital timer wiring harness (3/10; 4/7)

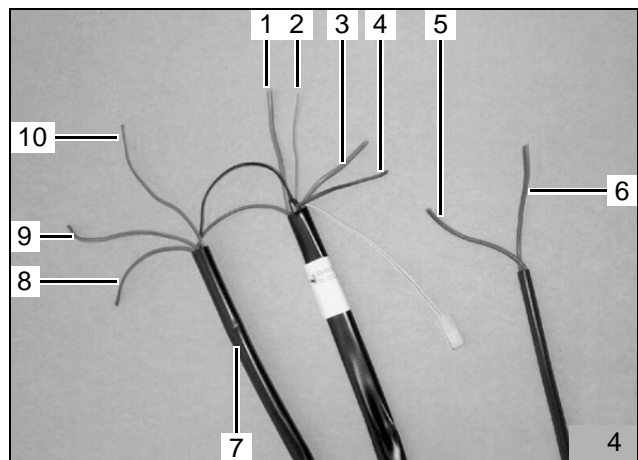
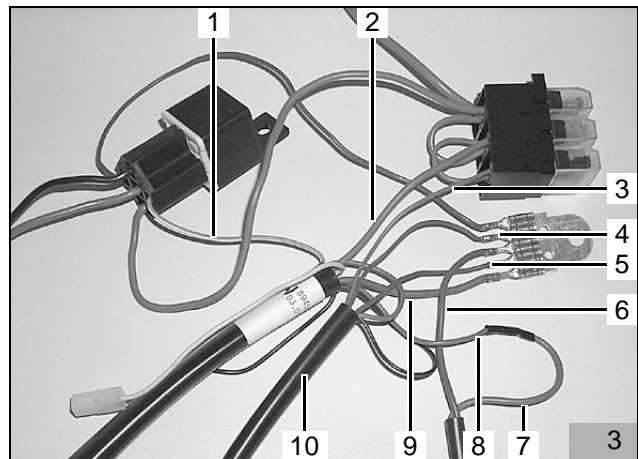

- Remove the rd cable (5/3) 2.5 mm² from the fuse holder to blower relay K3
- Remove the br cable (5/2) 0.75 mm² from the earth post to blower relay K3
- Remove the bl cable (5/1) 2.5 mm² from blower relay K3
- Remove the rd cable (5/7) 2.5 mm² from blower relay K3
- Remove the earth post (5/5)
- Remove blower relay K3 5/6) complete with its bracket
- Remove the fuse holder (5/4)

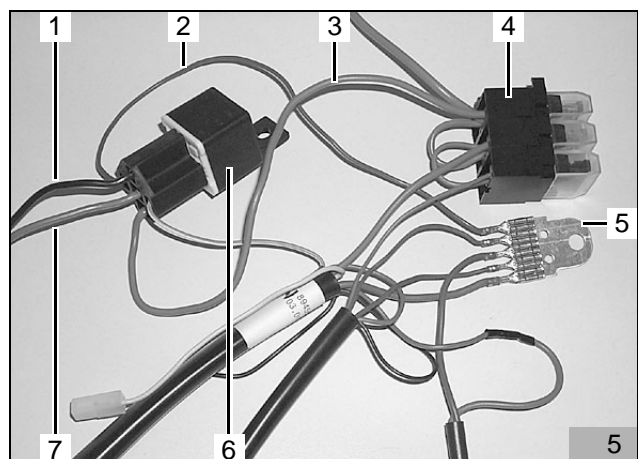

- Lay the prepared heater wiring harness (6/1; 7/1) to the heater installation site

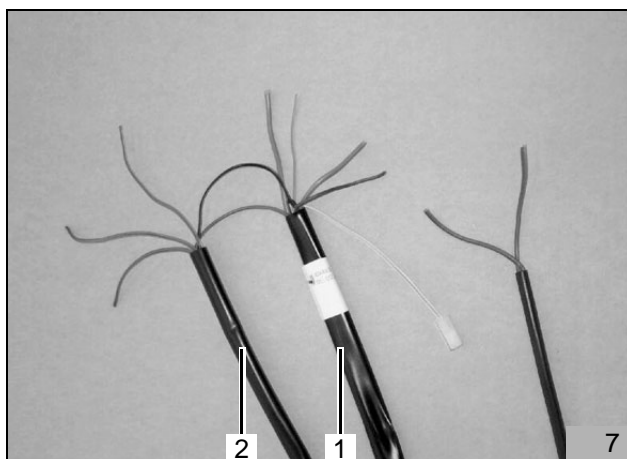
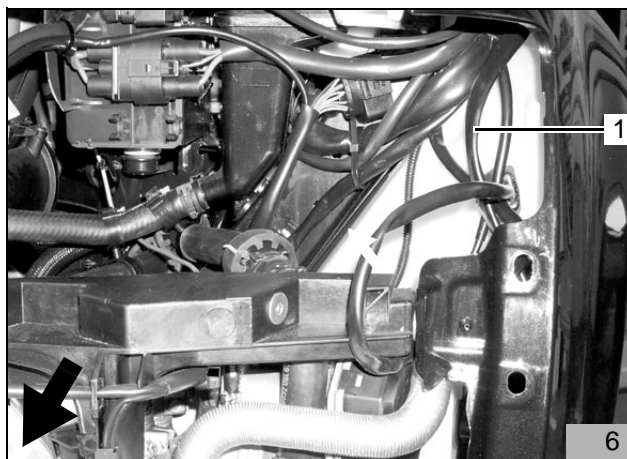

- Lay the heater wiring harness (8/6; 6/1) from the heater along the standard wiring harness (8/2) in the wheel arch to the passage hole (8/3) and into the interior as shown in Figure 8 and Figure 6
- Lay the digital timer wiring harness (7/2) starting with plug X9 through the passage hole (8/3) and into the interior
- Follow it with the heater wiring harness (8/1) as shown in Figure 8

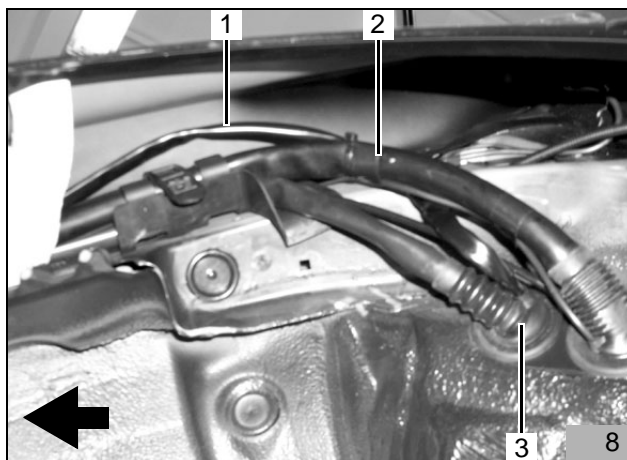

- Lay the heater wiring harness (9/1; 8/1) as shown in Figure 9 to the central electrical system

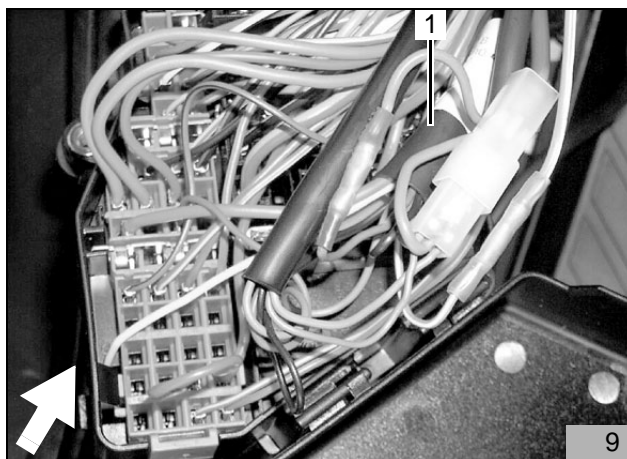

- Connect the bl cable (10/6) from the heater and the bl cable (10/2) to the dosing pump with butt connectors (10/1) as shown in Figure 10 (squeeze and shrink)
- Connect the gn/wt cable (10/5) from the heater to the enclosed gn/wt cable (10/3) with butt connectors (10/4) as shown in Figure 10 and Figure 11 (squeeze and shrink)

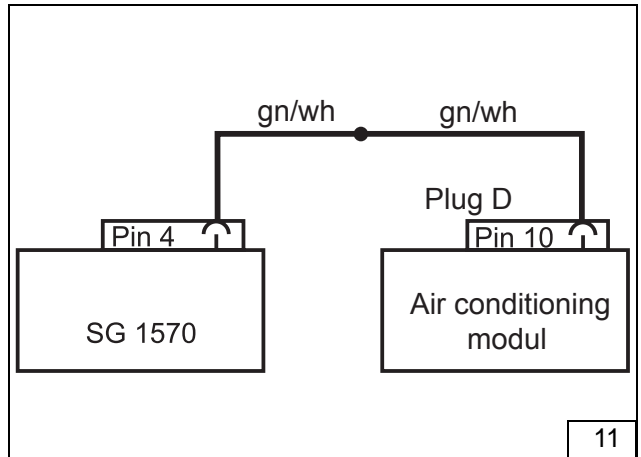
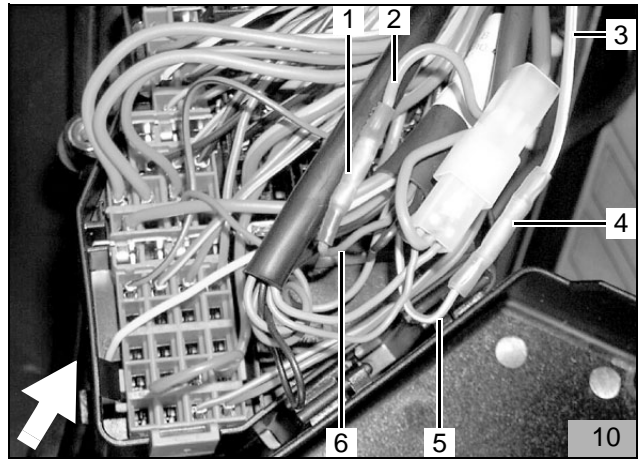

- Lay the gn/wt cable (12/1; 10/3) to the air-conditioning control module and crimp on the supplied microtimer
- Connect the gn/wt cable (12/1) to plug D (12/2) as shown in Figure 12 and Figure 11

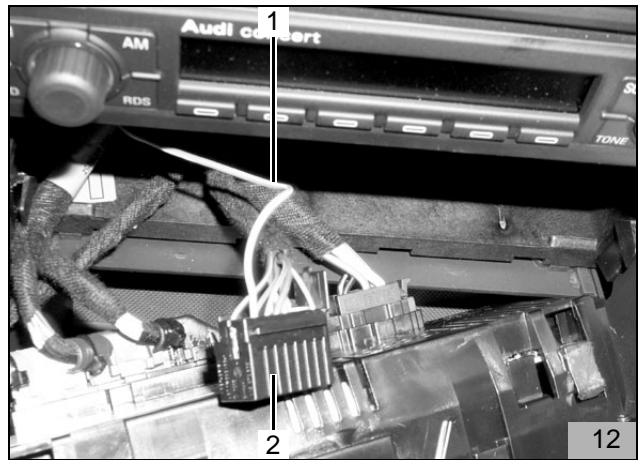

- Connect the br earth cables coming from the heater (13/1), going to the digital timer (13/5) (plug X9), coming from the digital timer wiring harness (13/6) and going to the dosing pump (13/4) to the br earth cable (13/2) 4.0mm² using blade connectors (13/3)

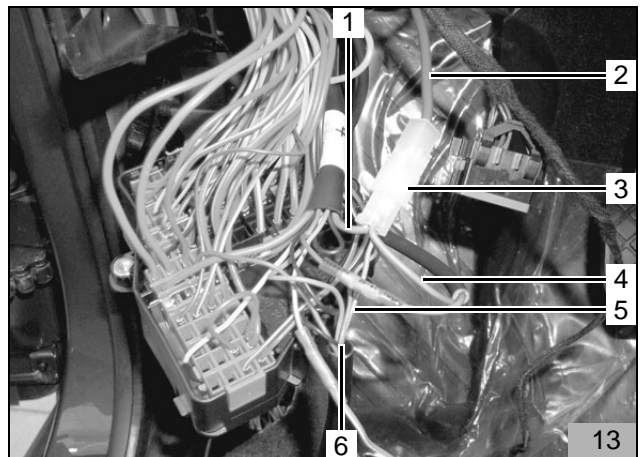

- Connect the br cable (14/1; 13/2) 4.0 mm² to the standard earth point (14/2) using the supplied 6 mm terminal lug

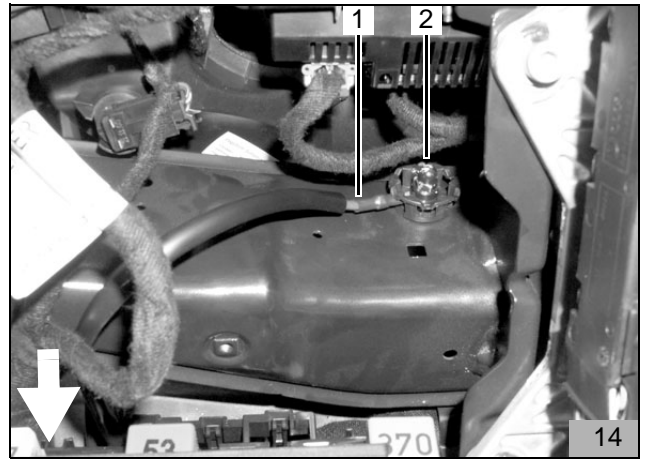

- Lay the supplied positive distributor (15/1,2) to the standard positive post (15/3) using a 6 mm terminal lug as shown in the Figure 15 and to the central electrical system

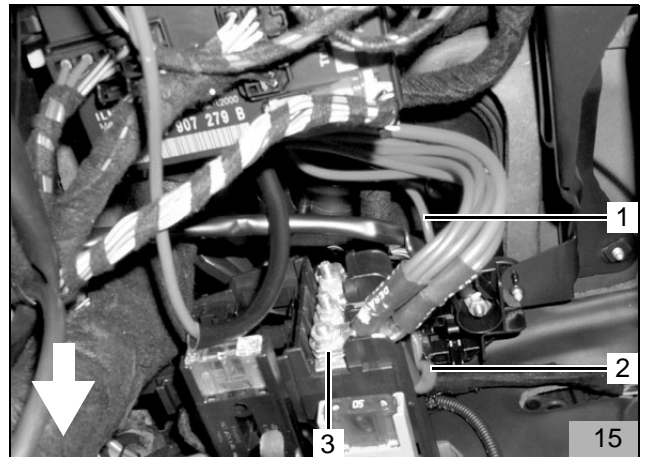

- Insert the positive cables (16/1,2,3) into the free fuse slots as shown in Figure 16
- Crimp the junior timer to the rd cable (16/4) 4.0 mm² from the heater
- Connect the rd cable (16/5) 4.0 mm² to the free fuse slot as shown in Figure 16
- Crimp the junior timer to the rd cable (16/4) 0.75 mm² from the digital timer
- Connect the rd cable (16/4) 0.75 mm² to the free fuse slot as shown in Figure 16

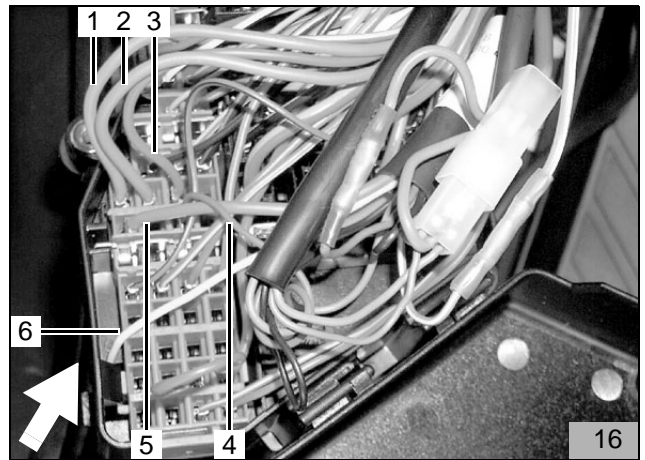

- Uncrimp the plug connector (17/1) from the diagnostic cable (17/2; 16/6)

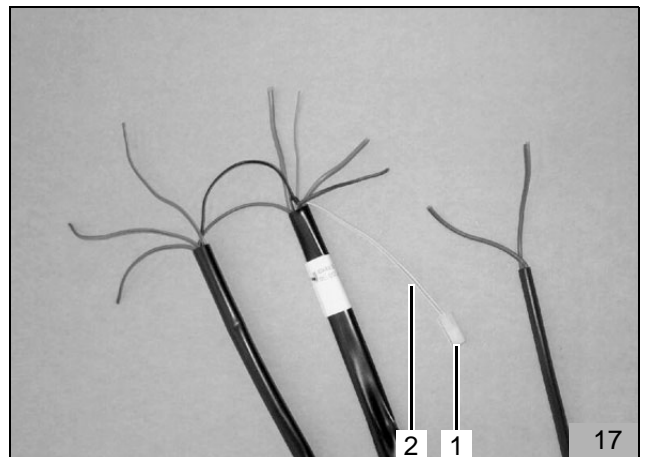

- Lay the diagnostic cable (18/2; 16/6) as shown in Figure 18 through the empty passage hole into the fuse holder
- Crimp the plug connector (18/2) back on to the diagnostic cable
- Insert a 3 A fuse (18/3) (violet) for the digital timer as shown in Figure 18
- Insert a 20 A fuse (18/1) (yellow) for the heater as shown in Figure 18

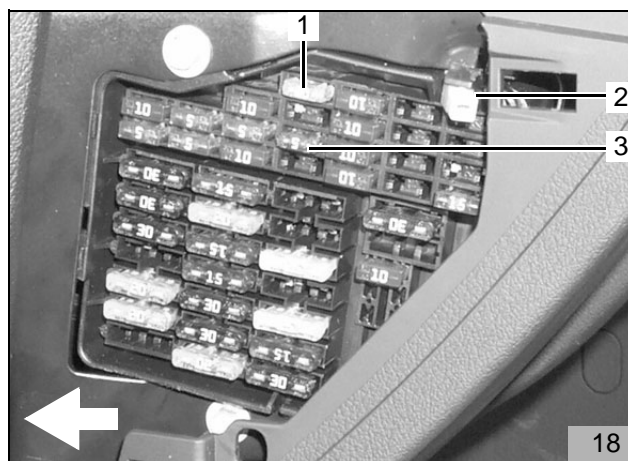

- Secure the wiring harnesses and cables with cable ties (19/1,2) as shown in Figure 19

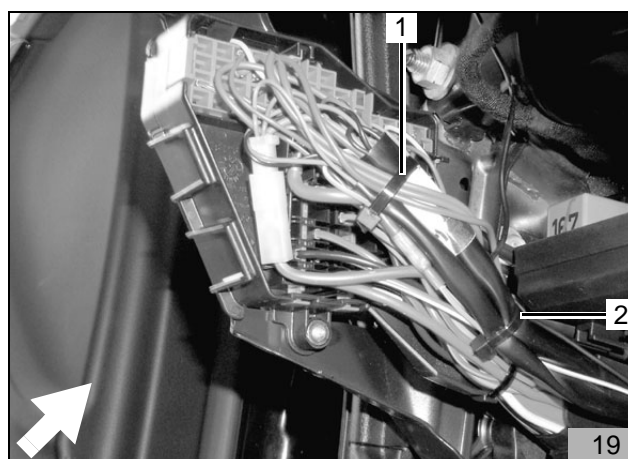

- Lay the digital timer wiring harness to the digital timer installation site
- Lay the dosing pump wiring harness (20/1) from the central electrical system to the standard wiring harness in the left door sills to the cable duct under the rear seat bench
- Lay the dosing pump wiring harness through the cable duct and then to the service flap on the tank fittings in the boot as shown in Figure 20

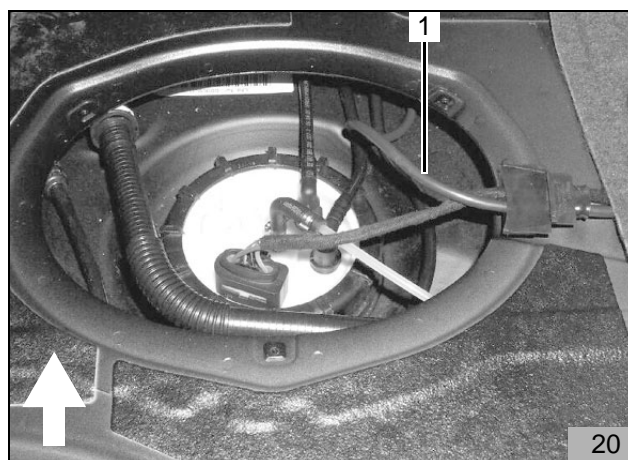

Digital timer and optional summer/winter switch

IMPORTANT:

Do not press on the LCD display as you install the digital timer

NOTE:

The installation site for the digital timer (21/1) shown in the figure is only a recommendation. Before installation, please agree the installation site with your customer

- Affix the drilling template for the digital timer (21/1) in the required position
- Drill two holes using the template
- Remove the template
- Install the mounting sleeve using a self-tapping screw

NOTE:

Check the direction of the locking teeth (see installation manual) Fit a chafing guard when you install the wiring harness.

- Thread the digital timer wiring harness through the hole and connect the plug to the digital timer
- Connect the digital timer

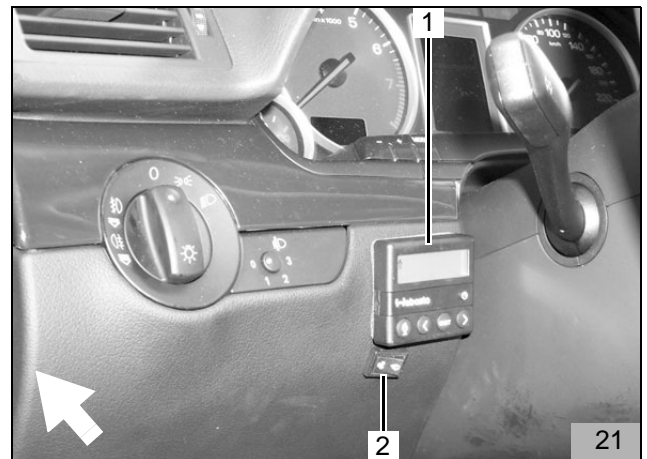

- Mark the holes for the summer/winter switch in the required position and drill the holes with a diameter of 12 mm
- Draw the nut and toothed washer over both cables
- Thread the brown and violet cables through the hole and connect them to the switch (bottom contacts) as shown in Figure 22
- Secure the summer/winter switch with a toothed washer and nut

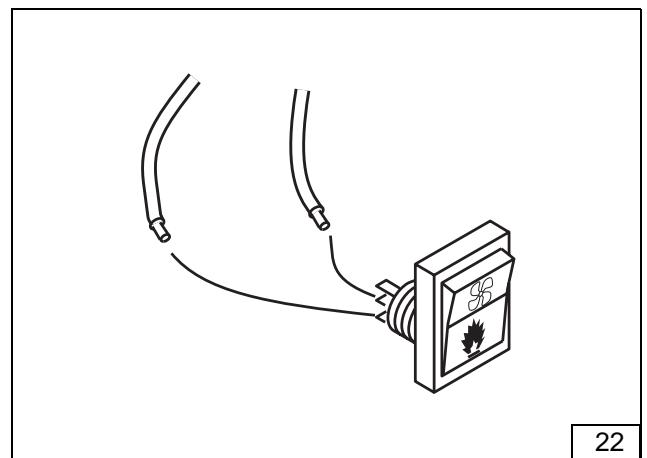

To install the heater

To prepare the heater installation site

- Place the holder for the heater on the existing holes (23/1,3) and mark the hole pattern (23/2)
- Drill a 9.0 mm hole (23/2) as shown in Figure 23
- Insert three rivet nuts M6 (23/1,2,3) into the holes

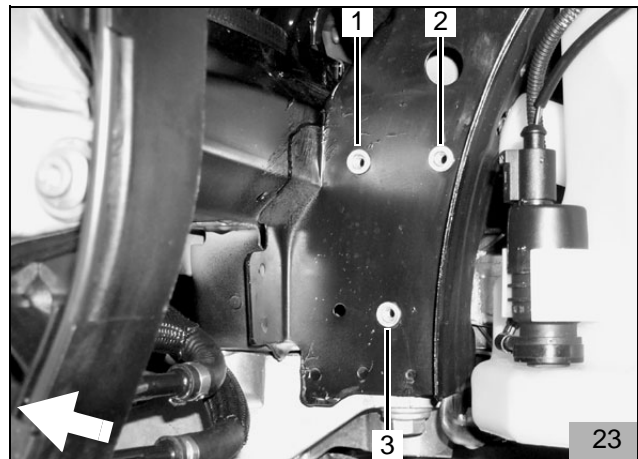

To prepare the heater

IMPORTANT:

Only use the special EJOT PT stud bolts supplied to secure the heater. (tightening torque 10 Nm)

NOTE:

Place two washers in position (24/4) between the heater and the holder

- Secure the holder (24/3) to the heater (24/1) using three Ejoy screws (24/4,5,6), placing two washers in position (24/4) between the heater (24/1) and the holder (25/3) (tightening torque 10 Nm)

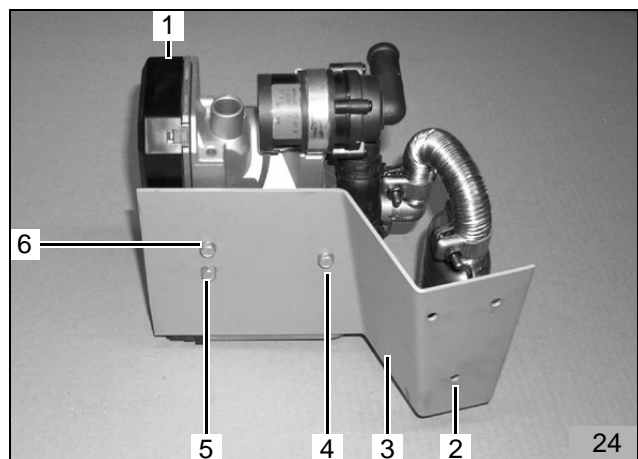

To prepare the exhaust pipe

IMPORTANT:

Ensure that you leave sufficient space to hoses and cables when you install the exhaust system

- Cut the exhaust pipe and exhaust pipe end piece as shown in Figure 25

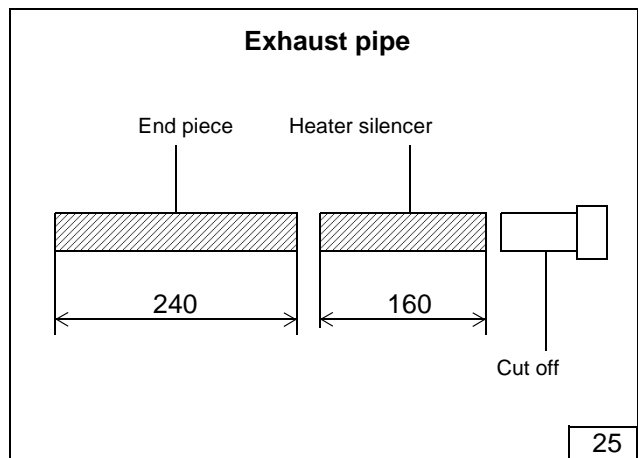

- Fit the exhaust bracket (26/3) to the heater and secure it with a hose clip
- Connect the 160 mm exhaust pipe (26/1) to the exhaust bracket (26/3) and secure it with a hose clip (26/2) as shown in Figure 26
- Connect the exhaust silencer (26/4) to the 160 mm exhaust pipe (26/1) and secure it with a hose clip (26/8) as shown in Figure 26
- Secure the bracket (26/6) to the exhaust silencer (26/4) using the screw M6x20 (26/5), body washer A7.4 and flanged nut M6 as shown in Figure 26

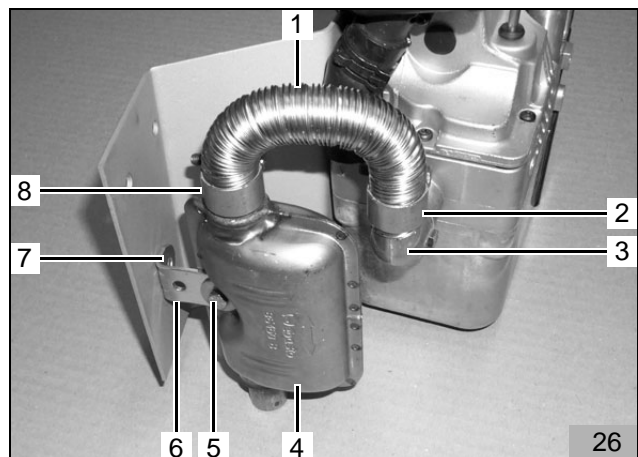

NOTE:

Align the bracket (26/6) as shown in Figure 26 so that the hole (26/7) lines up with hole (24/2).

The bracket (26/6) is secured later

- Connect the 240 mm exhaust pipe end piece (27/1) to the enclosed exhaust passage (27/2) and secure it with a hose clip (27/3) as shown in Figure 27
- Push the red rubber section (27/4) on to the exhaust pipe end piece and position it as shown in Figure 27

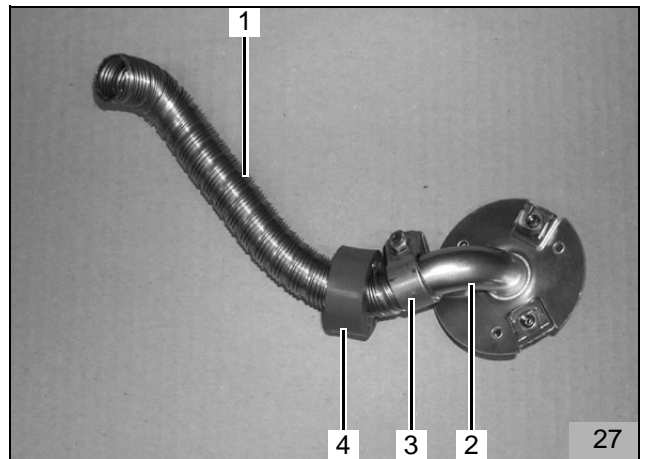
**To install the heater**

- Fit the edge protector (28/4) as shown in Figure 28
- Secure the holder (28/1) to the rivet nuts (29/1,2) using two screws M6x20 (28/2,3) and spring rings A6 as shown in Figure 28

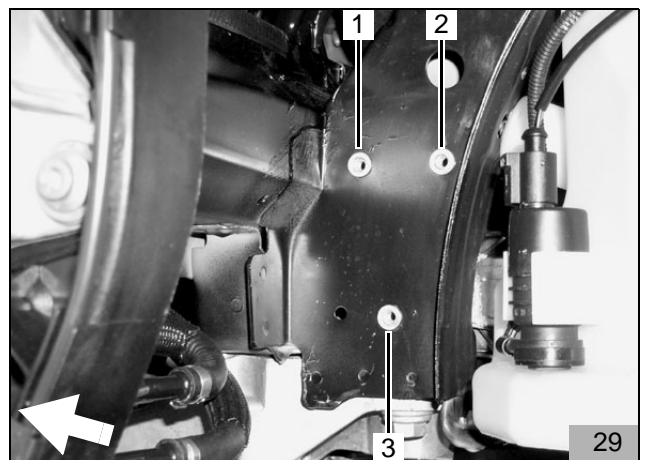
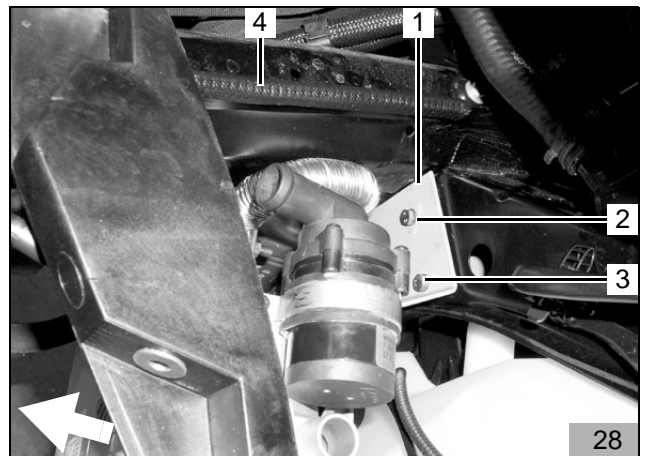

- Secure the holder (30/1) with the bracket (30/3) to the rivet nut (29/3) using the screw M6x20 (30/2) and spring ring A6 as shown in Figure 30

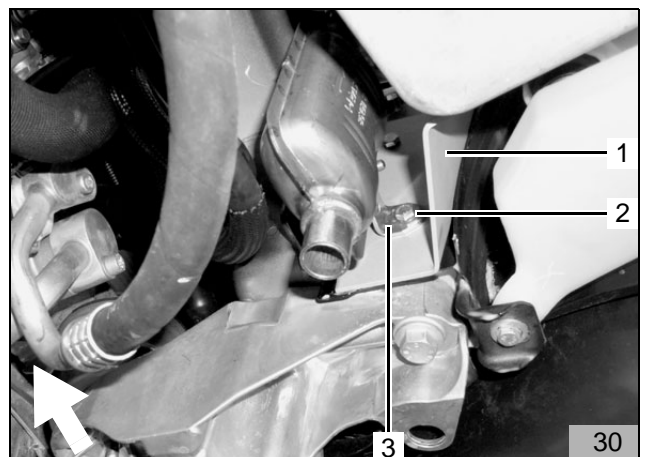

- Secure the strut (31/1) to the heater (31/3) using the Ejet screw (31/2) as shown in Figure 31 (tightening torque 10 Nm)

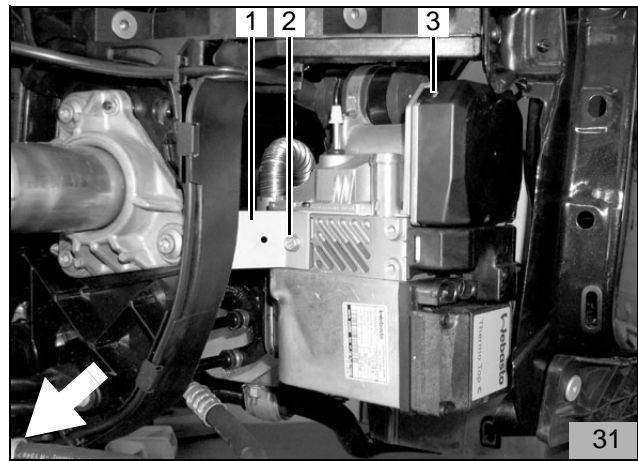

- Secure the strut (32/2; 31/1) to the existing screw (32/1) on the side member a flanged nut M8 as shown in Figure 32

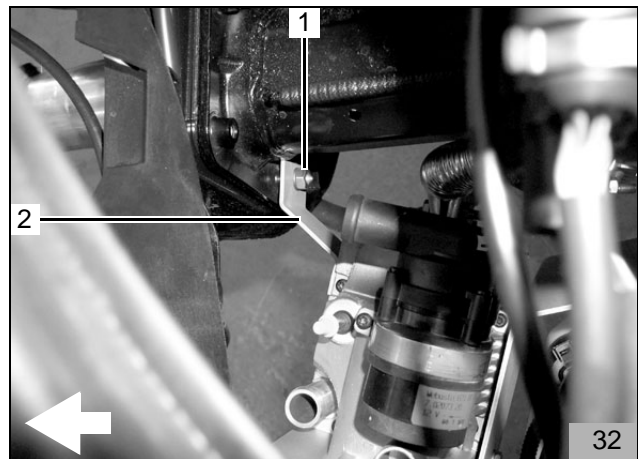

Integration in the water system

NOTE:

Catch escaping coolant water using a suitable container
 Install the water hoses with no kinks

The following describes how to integrate the heater into the car's coolant water system in an inline version (Figure 33)

Legend for Figure 33

- 1 Expansion tank
- 2 Radiator thermostat
- 3 Car engine
- 4 Circulating pump (heater)
- 5 Heater
- 6 Heating system heat exchanger (car)
- 7 Radiator

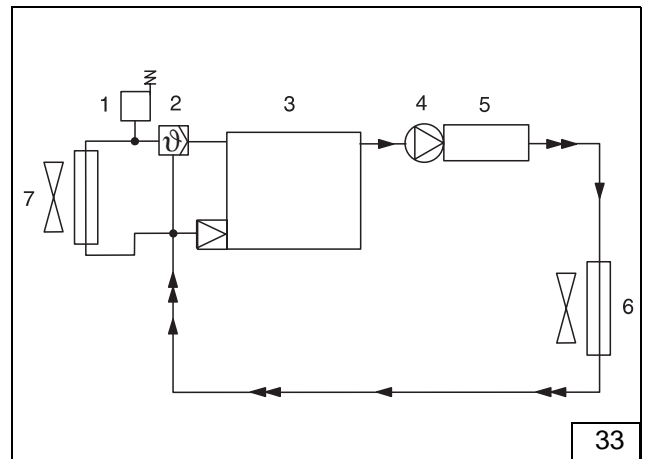

To prepare the water hoses

- Cut three lengths off the water hose supplied in the kit as shown in Figure 34:
- 1 x 840 mm + 180° bend (34/1)
 (from the standard water hose at the engine outlet to the heater water inlet)
- 1 x 800 mm (34/2)
 (from the 50 mm water hose (34/) to the standard hose section to the heat exchanger)
- 1 x 50 mm + 90° bend (34/3)
 (from the heater water outlet to the 800 mm water hose (34/2))
- Remove the standard water hose (35/1,2,3) from the engine outlet to the heat exchanger water inlet
- Cut the standard water hose (35/1,2,3) at the markings (arrows)

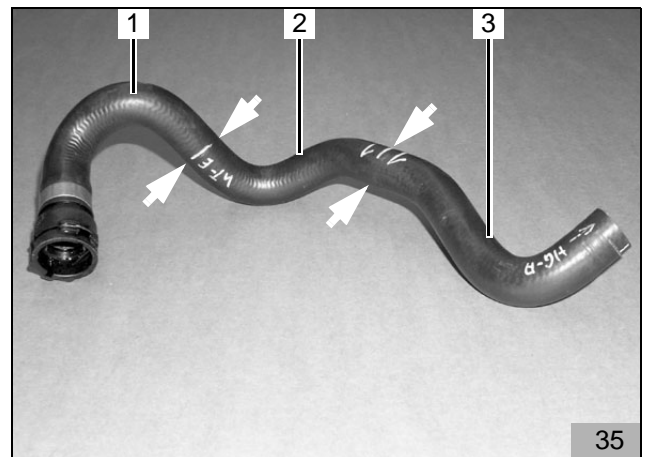
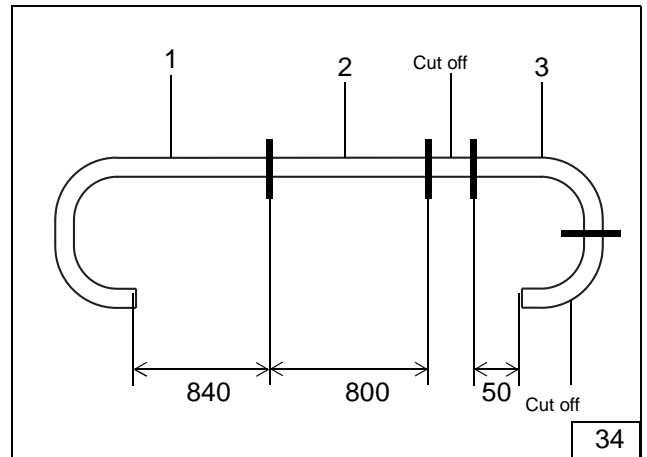

- Connect the 50 mm water hose (36/1) at the 90° bend to the 800 mm water hose (36/3) using the 20 x 20 connection pipe and spring strip clips as shown in Figure 36
- Push four black rubber sections (36/2,4,5,6) on to the 800 mm water hose (36/3)
- Push three black rubber sections (36/7,8,9) on to the 840 mm water hose (36/10) as shown in Figure 36

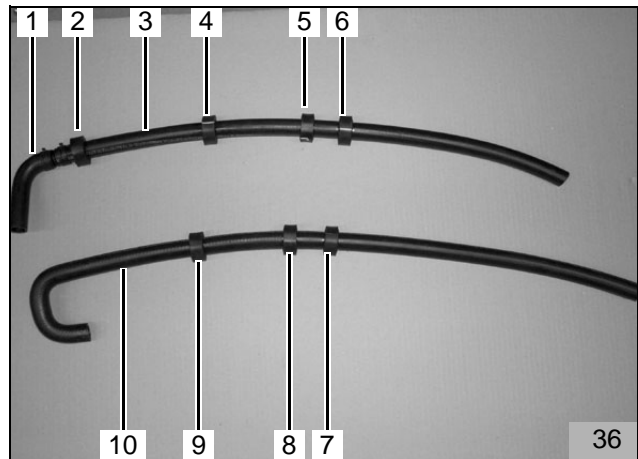

- Position the black rubber sections (36/2,4,5,6) as shown in Figure 37
- Position the black rubber sections (36/7,8,9) as shown in Figure 37

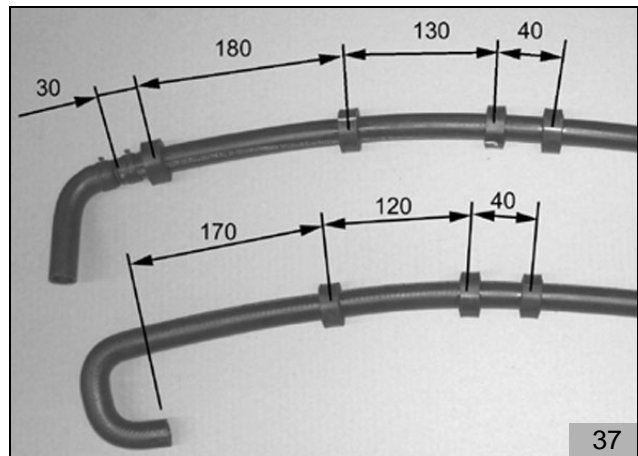

To install the water hoses

- Connect the 50 mm water hose (38/2; 36/1) to the heater's water outlet
- Align the connection to the 800 mm water hose (38/1) as shown in Figure 38
- Secure the 50 mm water hose (38/2) with a spring strip clip (38/3)
- Connect the 840 mm water hose (38/5; 36/10) with a 180° bend as shown in Figure 38 to the heater water inlet and secure it with a spring strip clip (38/4)

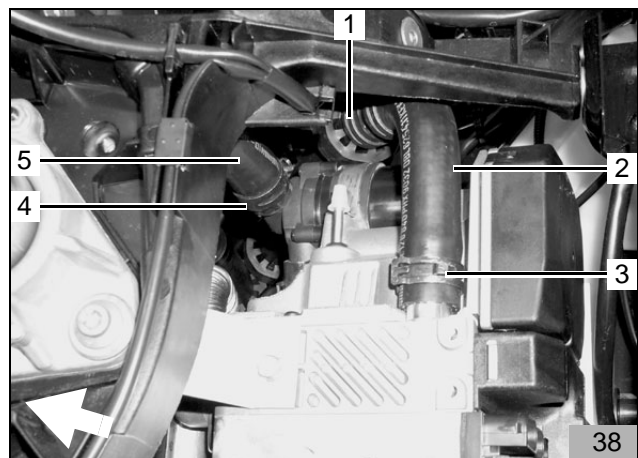

- Connect the 800 mm water hose (39/1; 36/3) from the heater's water outlet to the heat exchanger water inlet as shown in Figure 39
- Connect the 840 mm water hose (39/2; 36/10) from the heater's water inlet to the engine outlet as shown in Figure 39



- Connect the standard hose section (40/9; 41/1) to the engine outlet and the 840 mm water hose (40/8) as shown in Figure 40 using a connection pipe 20 x 20 and space-saving clips (40/1,2)
- Connect the standard hose clips (40/4; 41/3) and the 800 mm water hose (40/7) as shown in Figure 40 using a connection pipe 20 x 20 and space-saving clips (40/5,6)
- Push the black rubber section (40/3) on to the hose section 40/4) and position it as shown in Figure 40

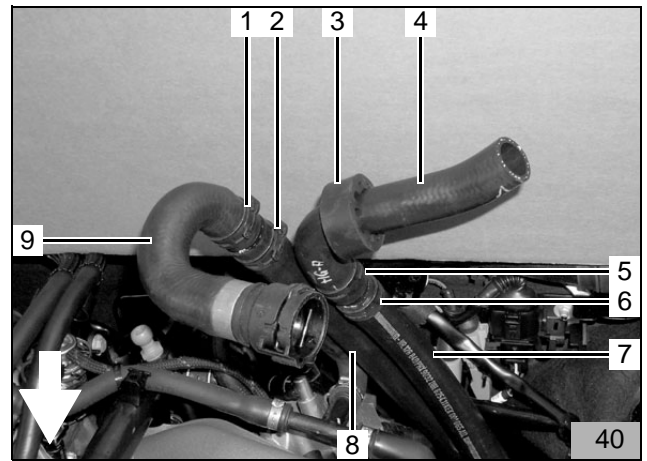

- Connect the standard hose section (41/1; 40/9) to the engine outlet using a hose coupling

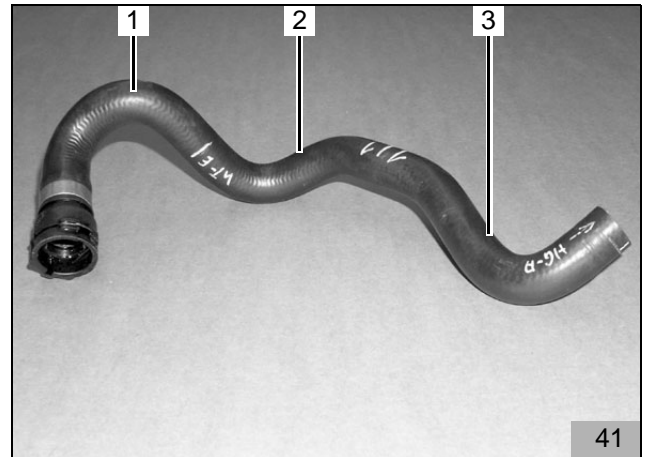

- Lay the hose section (42/5; 40/4) as shown in Figure 42 through the standard passage hole into the radiator tank
- Connect the hose section (42/5) and the standard hose section (42/3; 41/2) as shown in Figure 42 using a connection pipe 20 x 20 and spring strip clips (42/4)
- Secure the hose section (42/3) to the heat exchanger water inlet (42/1) with a spring strip clip (42/2)

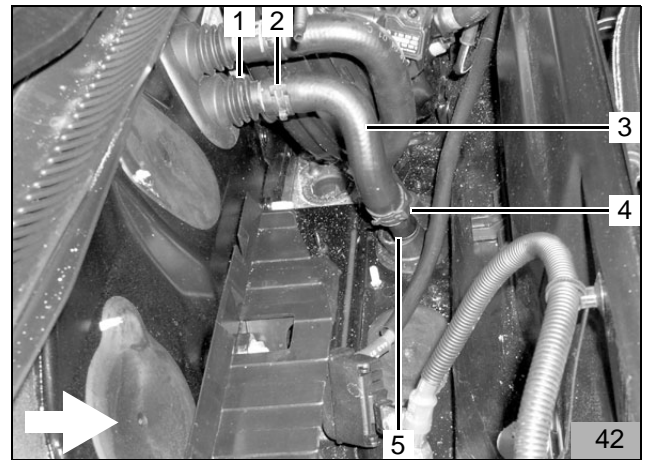

- Position the black rubber section (43/1) as shown in Figure 43



- Position the black rubber section (44/2) on the 840 mm water hose as shown in Figure 44
- Position the black rubber section (44/1) on the 800 mm water hose as shown in Figure 44

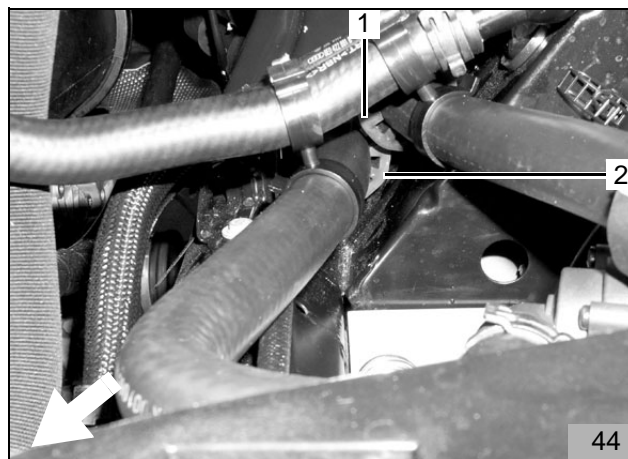

- Position the black rubber sections (45/2,3) on the 840 mm water hose as shown in Figure 45
- Position the black rubber sections (45/1,4) on the 800 mm water hose as shown in Figure 45

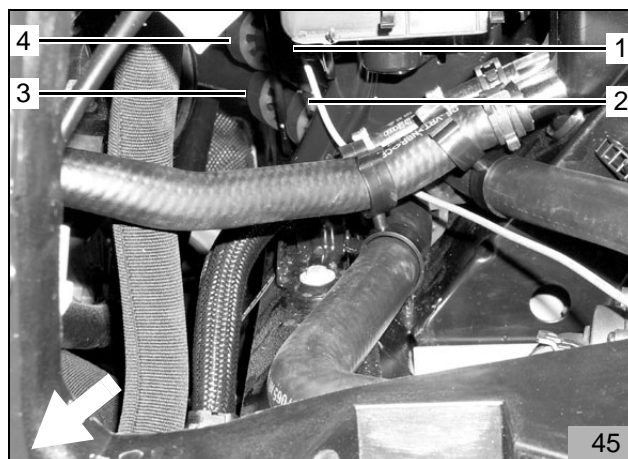

- Insert the supplied spacer (46/3) between the 800 mm water hose (46/1) and the 840 mm water hose (46/2) as shown in Figure 46

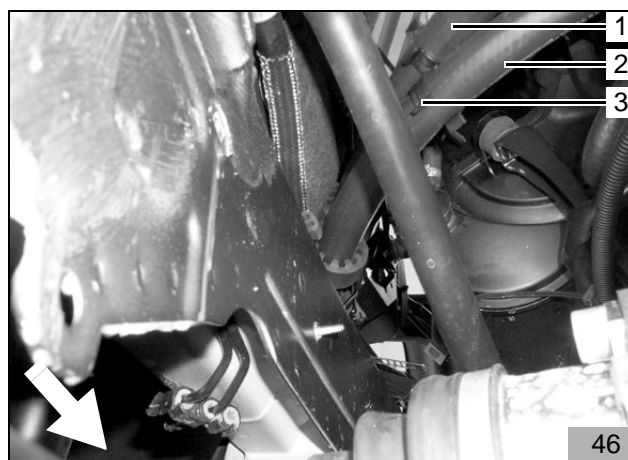

- Secure the 800 mm water hose (47/3) to the standard hose (47/1) as shown in Figure 47 using the supplied spacer (47/2)
- Secure the 840 mm water hose (47/5) to the standard hose (47/1) as shown in Figure 47 using the supplied spacer (47/4)

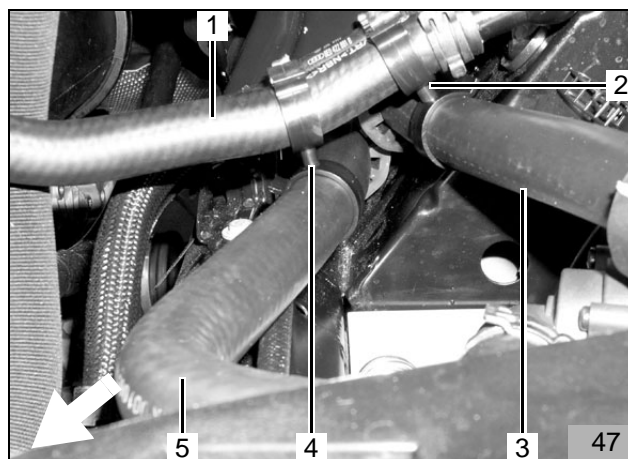

Integration in the fuel system

IMPORTANT:

Open the filler cap, release the pressure from the fuel tank system and close the filler cap again

Lay the fuel lines so that they are protected from stones and heat

Fit a chafing guard on the fuel lines around sharp edges

Install the fuel lines with no kinks

Dosing pump

NOTE:

Check the installation site of the dosing pump, see "installation manual"

- Secure the bracket (48/2) to the existing screw M8 (48/1) as shown in Figure 48
- Secure the dosing pump (48/4) to the bracket (48/2) using an anti-vibration mount (48/3), rubberised pipe clip (48/5) and flanged nuts as shown in Figure 48

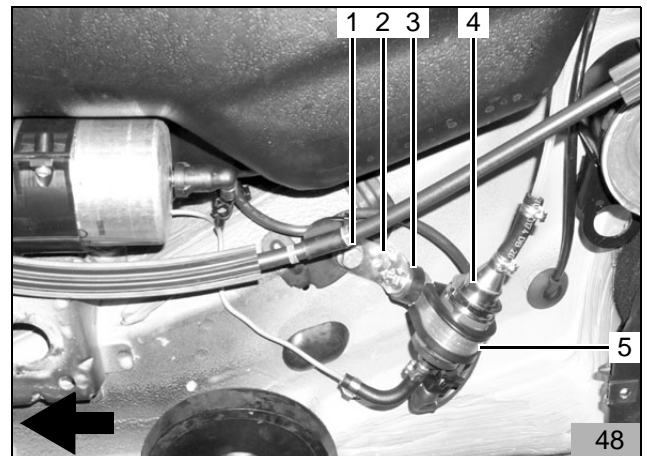

- Connect the supplied 90° shaped hose (49/3) (internal diameter rising from 3.5 mm to 4.5 mm) to the outfeed from the dosing pump (49/1) (side with the plug) using the end with an internal diameter of 4.5 mm
- Align the 90° shaped hose (49/3) as shown in Figure 49 and secure it using a 9 mm Cailau clip
- Insert the metal fuel line (49/4) into the end of the 90° shaped hose (49/3) with an internal diameter of 3.5 mm and secure it with an 8 mm Cailau clip
- Lay the dosing pump wiring harness (49/2) to the dosing pump and cut it to length
- Push a rubber grommet on to the dosing pump wiring harness, crimp on a blade terminal, complete the plug casing and connect the wiring harness to the dosing pump as shown in Figure 49

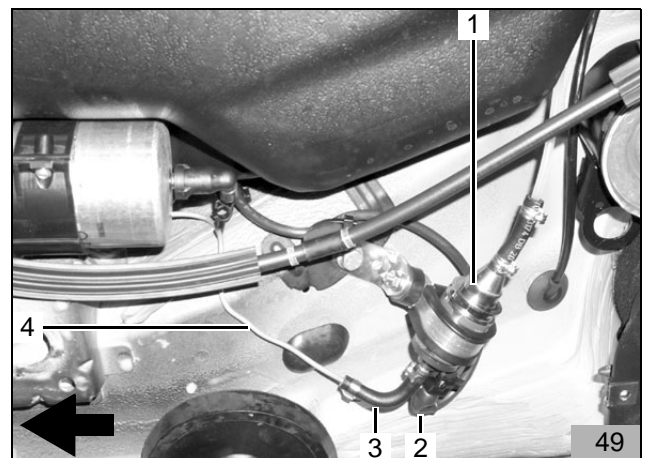

To install the metal fuel line

- Secure the metal fuel line (50/3) to the dosing pump wiring harness (50/2) using the spacer (50/1) as shown in Figure 50

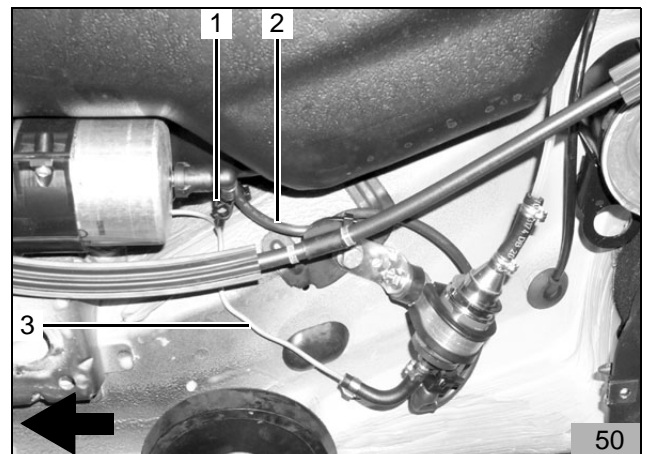

- Lay the metal fuel line (51/4) forwards to the passage hole into the under-bonnet compartment as shown in Figure 50 to Figure 54
- Secure the metal fuel line (51/4) using the clips supplied (51/2,3) as shown in Figure 51

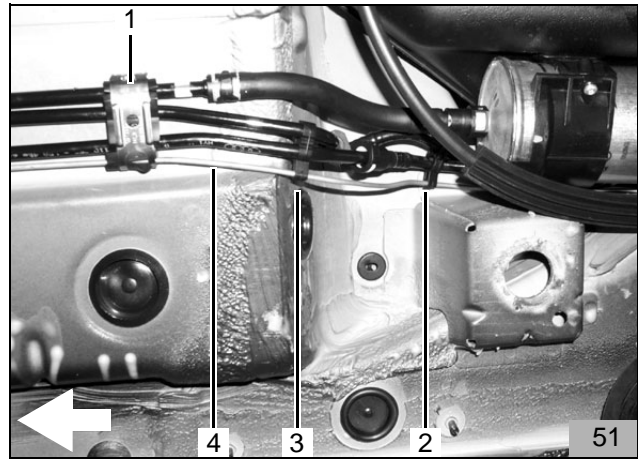

- Replace the holders (52/1,3,4,5; 51/1) for the standard fuel lines with the supplied holders

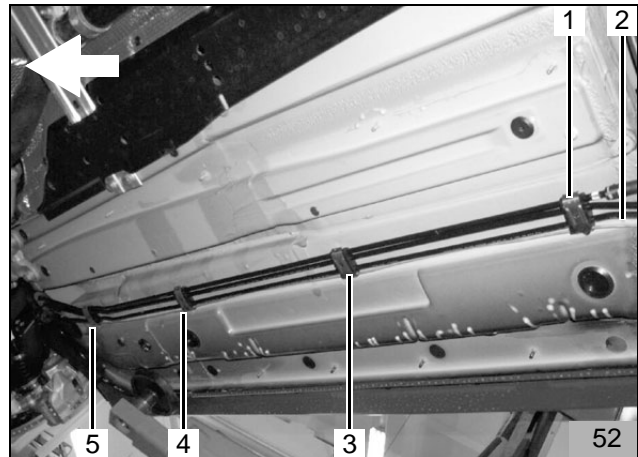

- Secure the metal fuel line (53/2) using the clips supplied (53/1.3) as shown in Figure 53

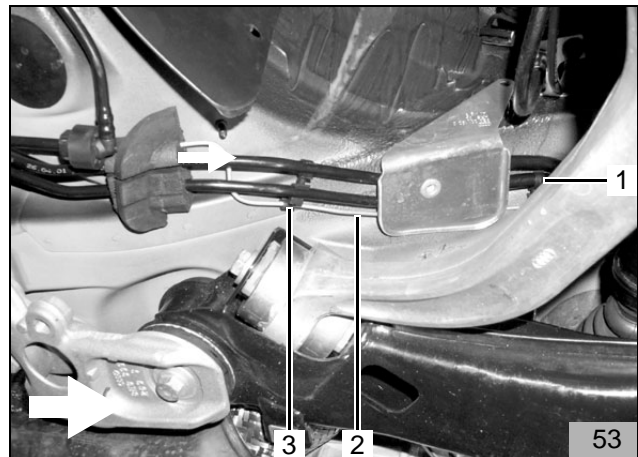

- Secure the metal fuel line (54/4) using the clip supplied (54/3) as shown in Figure 54
- Insert the additional supplied guide rubber (54/2) as shown in Figure 54
- Lay the metal fuel line (54/4) through the standard passage (54/1) into the under-bonnet compartment as shown in Figure 54

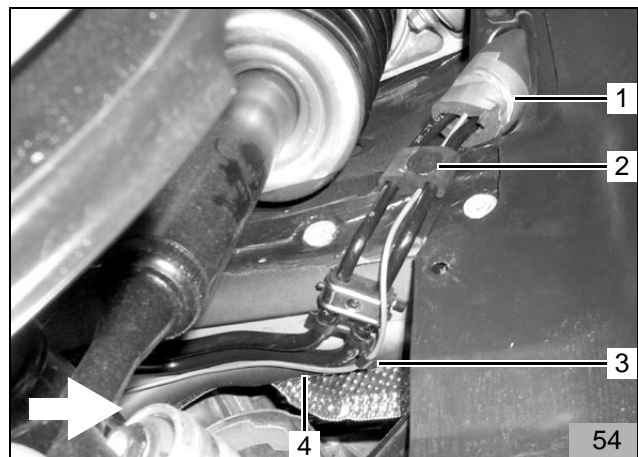

- Lay the metal fuel line (55/1) to the installation site for the heater as shown in Figure 55 to Figure 60
- Secure the metal fuel line (55/1) using the spacers supplied (55/2,3) as shown in Figure 55

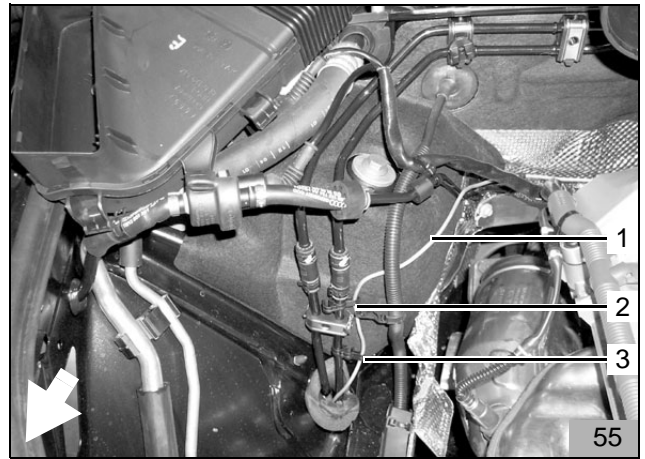

- Secure the metal fuel line (56/3) using the spacers supplied (56/1.2) as shown in Figure 56

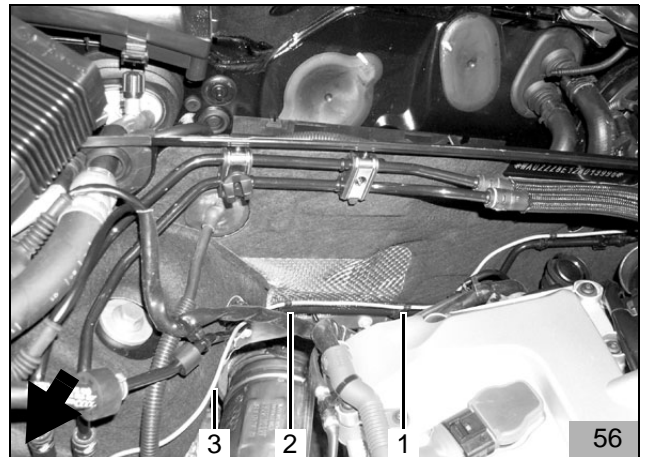

- Secure the metal fuel line (57/2) using the spacers supplied (57/1.3) as shown in Figure 57

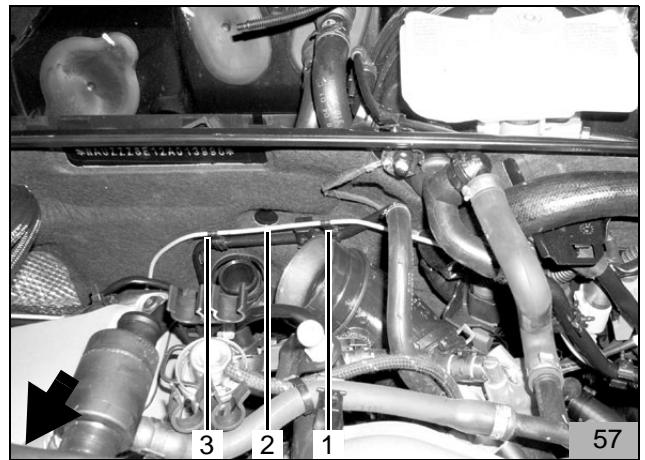

- Secure the metal fuel line (58/1,5) using the spacers supplied (58/2,3,4,6) as shown in Figure 58

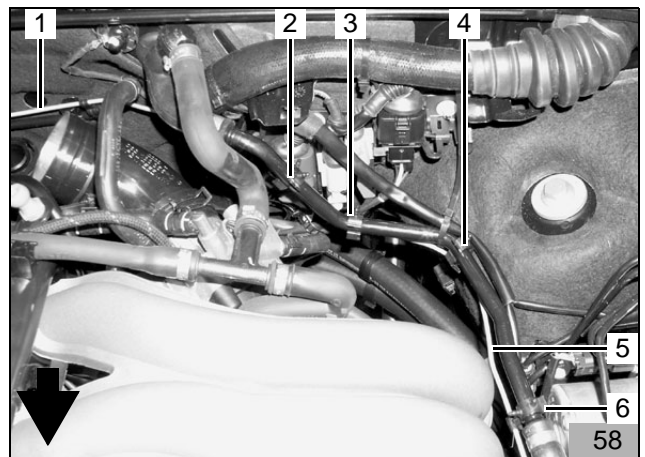

- Clip the cable tie (59/2) into the existing hole as shown in Figure 59 and secure the metal fuel line (59/1)

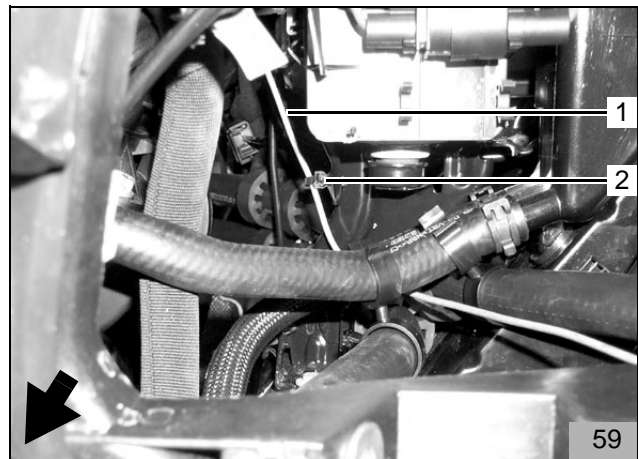

- Connect the shaped hose (60/2) (internal diameter rising from 3.5 mm to 4.5 mm) to the heater (60/5) using the end with an internal diameter of 4.5 mm as shown in Figure 60 and secure it with a 9 mm Cailau clip (60/4)
- Insert the metal fuel line (60/1) into the end of the shaped hose with an internal diameter of 3.5 mm and secure it with an 8 mm Cailau clip (60/3)

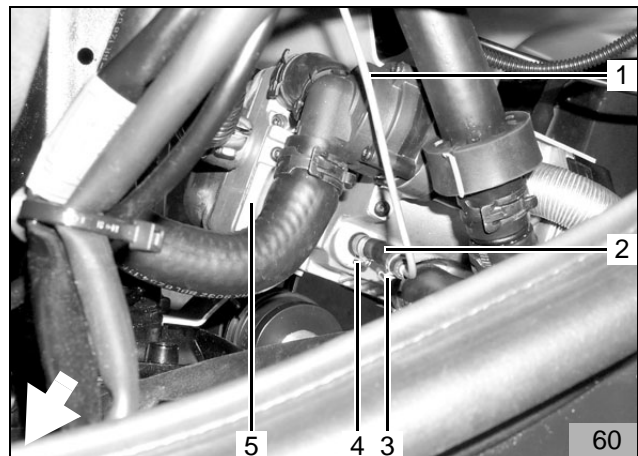

Fuel extraction

The fuel is extracted using the tank extracting device from the tank fittings

- Cut the supplied tank extracting device (61/1) to length as shown in Figure 61
- Cut the supplied fuel hose (61/2) to length as shown in Figure 61 (150 mm extended length)
- Cut the supplied riser pipe (61/3) to length as shown in Figure 61

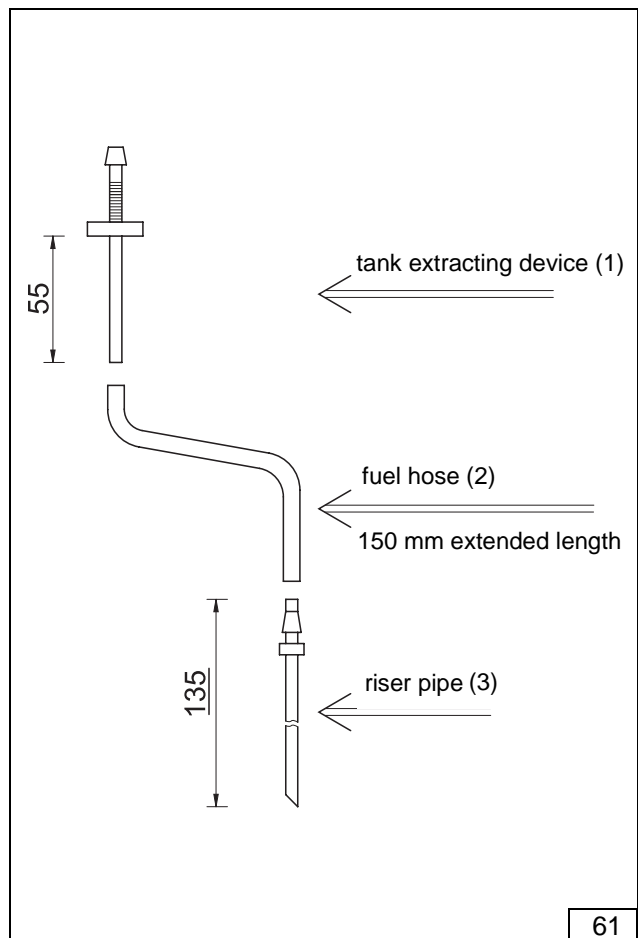

IMPORTANT

Open the car's filler cap, vent the tank and close the filler cap again

Catch escaping fuel using a suitable container

- Remove the tank fittings (62/1) following the manufacturer's instructions
- Drill a 6.0 mm hole in position (62/2) in the tank fittings

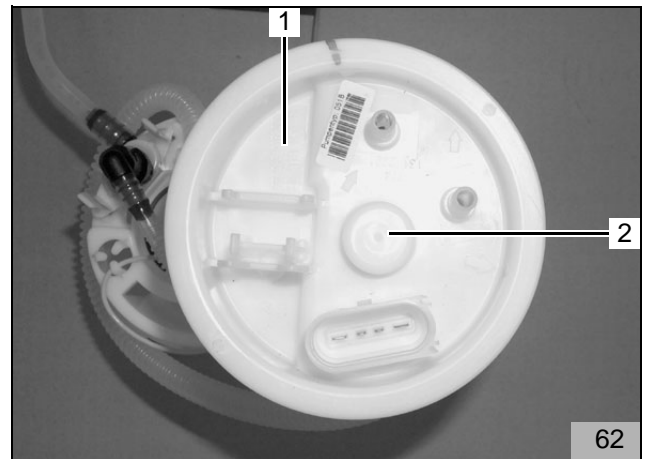

- Secure the tank extracting device (63/6; 64/6) in the tank fittings (63/1; 64/1) as described in the supplied installation manual
- Push the fuel hose (63/4; 64/4) on to the tank extracting device as shown in Figure 63 and Figure 64
- Secure the fuel hose using the supplied 6.6 mm hose clip (63/5; 64/5) as shown in Figure 63 and Figure 64

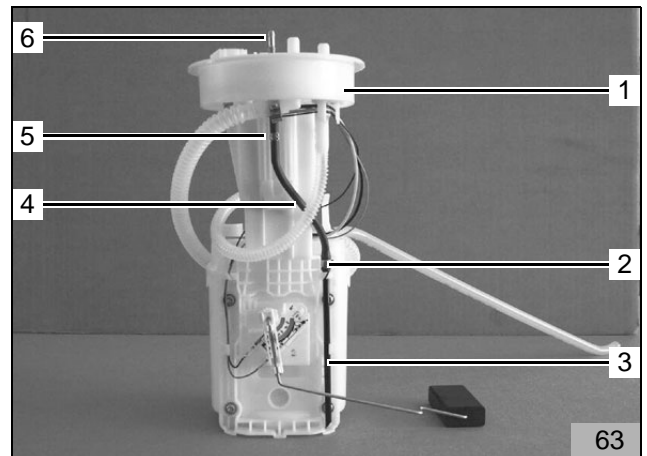

- Insert the riser pipe (64/3; 63/3) into the tank fittings as shown in Figure 64 and Figure 63
- Push the fuel hose (64/4; 63/4) on to the riser pipe
- Secure the fuel hose using the supplied 8.0 mm hose clip (64/2; 63/2) as shown in Figure 64 and Figure 63

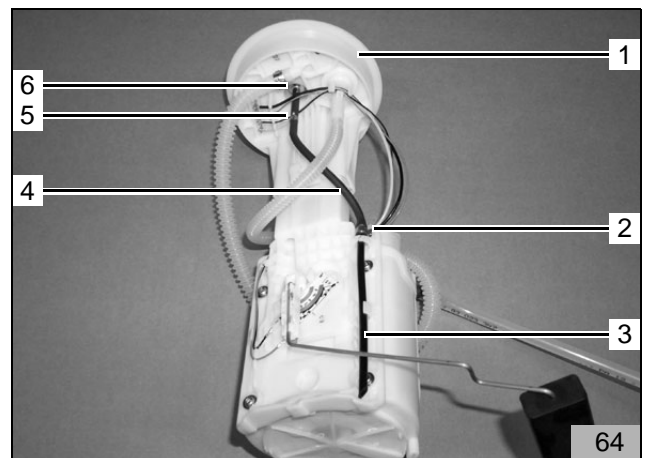

- Connect the supplied 90° shaped hose (65/1) (internal diameter rising from 3.5 mm to 4.5 mm) to the tank extracting device (65/3) using the end with an internal diameter of 3.5 mm
- Secure the 90° shaped hose using the supplied 9 mm Cailau clip (65/2) as shown in Figure 65
- Install the tank fittings again as described by the manufacturer

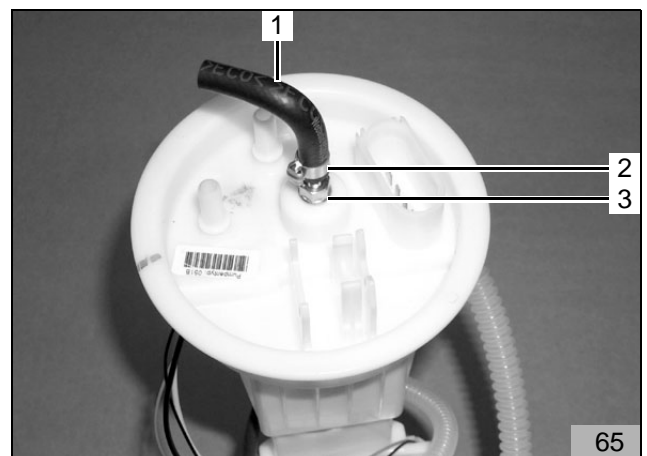

- Insert the Mecanyl fuel line (66/3) into the 90° shaped hose (66/1; 65/1) and secure it with a 10 mm Cailau clip as shown in Figure 66

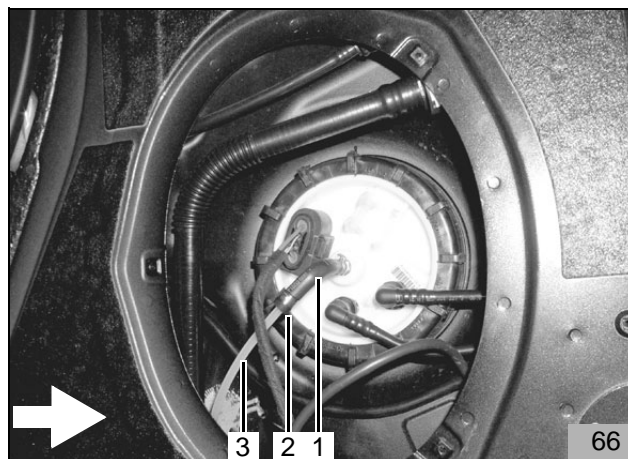

- Lay the Mecanyl fuel line (67/1; 66/3) to the intake side of the dosing pump (67/3) and cut it to length
- Connect the Mecanyl fuel line (67/1) as shown in Figure 67 with the hose section (67/2) 10 mm Cailau clips
- Secure all cables and wiring harnesses with cable ties

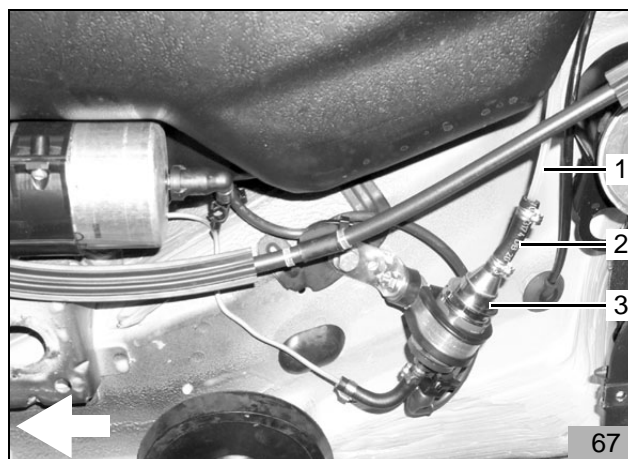

Exhaust system

- Connect the prepared exhaust pipe end piece (68/3; 69/3) to the exhaust silencer (68/1; 69/1) as shown in Figure 68 and Figure 69 and secure it with a hose clip (68/2; 69/2)

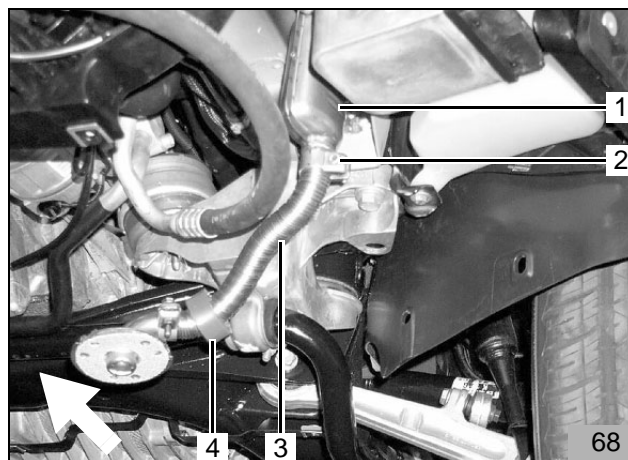

- Position the red rubber section (68/4; 69/4) on the exhaust pipe end piece (68/3; 69/3) as shown in Figure 68 and Figure 69

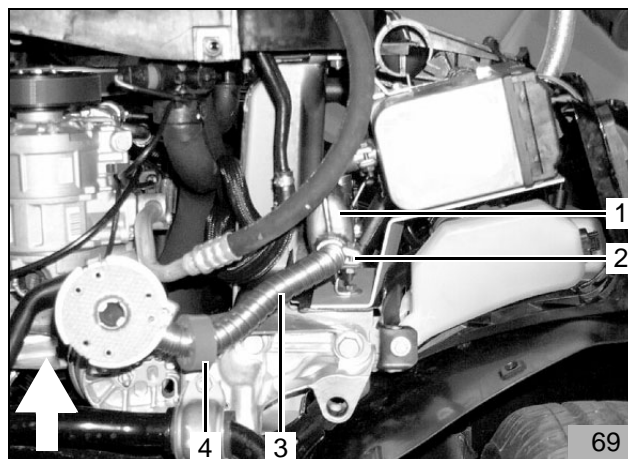

Combustion air intake line

NOTE:

Check the installation site of the air intake silencer, see "installation manual"

- Insert the clip (70/2) for the combustion air intake silencer into the hole in the strut as shown in Figure 70 and secure it from the rear using a bolt mounting
- Connect the combustion air intake line (71/1) with the slotted side on the heater combustion air port and secure it with a hose clip
- Lay the combustion air intake line as shown in Figure 71
- Screw the combustion air intake silencer (71/2) as far as possible into the combustion air intake line
- Insert the combustion air intake silencer into the retaining clip (71/3) as shown in Figure 71

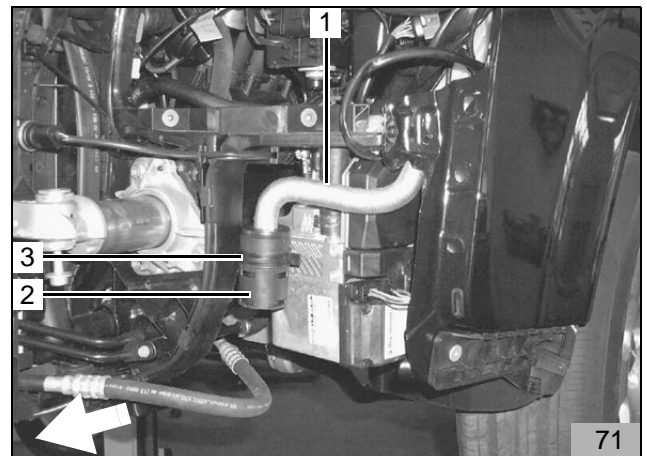
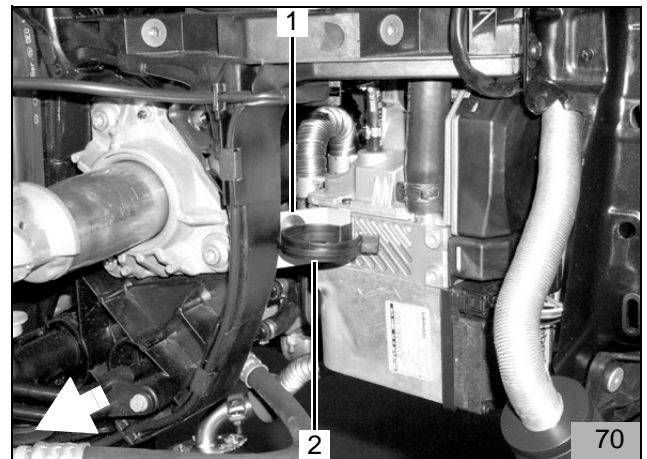

Concluding work

- As you fit the underride guard, secure the exhaust passage (72/1) to the existing holes in the underride guard with three screws M5x20 (72/2,3,4) and body washers

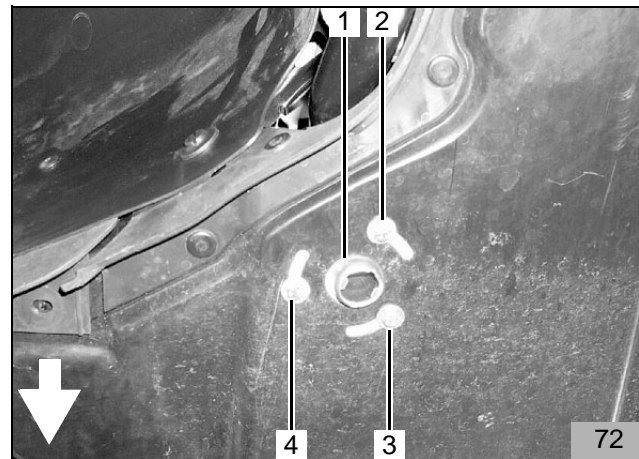

- Install and connect the battery
- Install all the removed parts in reverse
- Check that all hose lines, hose and pipe clips and all electrical connections are secure
- Secure all loose lines and cables with cable ties
- Take all tools, such as clamping claws, etc. out of the under-bonnet compartment
- Spray the heater components with anti-corrosive wax (Tectyl ML, order No. 111329)

IMPORTANT:

Only use genuine Audi coolant

- Start the engine, bleed the water system as described in the repair guidelines, top up the coolant
- Switch on the Webasto heating system, see "operating manual/installation manual"

Operating instructions for the end customer**NOTE:**

Please cut out and hand this page to the end customer

Additional heating system fuse assignment

- Heating system fuse (73/1)
20 A (yellow)
- Digital timer fuse (73/3)
3 A (violet)
- Webasto diagnostic plug (73/2)

To operate the additional heating system

- Set the temperature to 28 °C and Defrost before you switch off the ignition

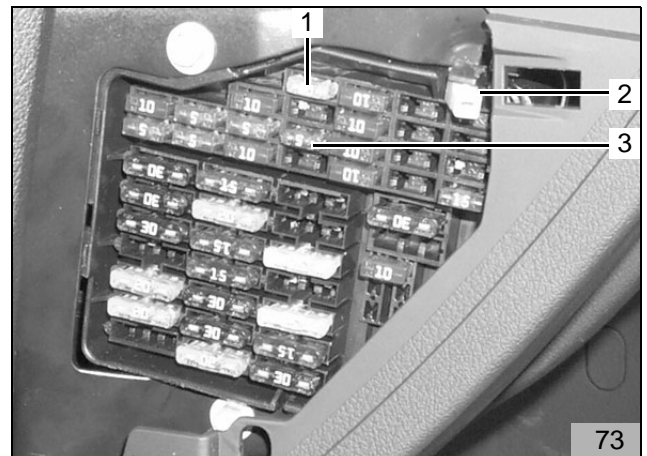

Space for notes

Space for notes



Feel the drive

Webasto Thermosysteme International GmbH
Postfach 80 - D-82132 Stockdorf - Hotline 0 18 05 / 93 22 78
Hotfax (0395) 55 92-353 - <http://www.webasto.de>