

Water Heater Unit



Feel the drive

Thermo Top E Additional Heater



00 0003

Thermo Top C Additional Heater



00 0002

Thermo Top P Additional Heater



00 0104

Installation Instructions

Audi A4 1.9 + 2.0 TDI

Diesel

from Model Year 2006

For left-hand drive vehicles only

Also on vehicles with diesel particle filter



WARNING!

Hazard warning:

Incorrect installation or repair of Webasto heating systems may cause a fire or result in the emission of carbon monoxide, which can be fatal. Serious or fatal injuries can be caused as a result.

Specialist company training, technical documentation, specialized tools and equipment are required to install and repair Webasto heating and cooling systems.

NEVER attempt to install or repair Webasto heating or cooling systems if you have not successfully completed the company training and thereby acquired the required technical skills, or if you do not have access to the required technical documentation, tools and equipment needed to carry out correct installation and repairs.

ALWAYS follow all Webasto installation and repair instructions and observe all warnings.

Webasto does not accept any liability for defects and damage that are attributable to installation by untrained staff.

Table of Contents

Validity	2	Preparing installation location	9
Heater Unit/Installation Kit	3	Preparing heater unit	9
Foreword	3	Installing heater unit	10
General Instructions	3	Coolant connection	11
Special Tools	3	Combustion air	15
Explanatory Notes on Document	4	Fuel Connection	16
Preliminary Work	5	Exhaust system	19
Heater unit installation location	5	Final Work	21
Electrical Connections	6	Operating Instructions for End Customer	22
Fan controller	7	Template for Perforated Fastening Strap	23
Remote option (Telestart)	8	Template for Fuel Standpipe	24

Validity

Manufacturer	Model	Type	EG-BE No./ABE
Audi	A4	8E	e1 * 2001/116 * 0151 * ...

Engine type	Engine model	Output in kW	Displacement in cm ³
BKE	Diesel	85	1896
BRB	Diesel	85	1896
AWX	Diesel	96	1896
BLB	Diesel	103	1968
BPW	Diesel	103	1968
BRE	Diesel	103	1968
BRD	Diesel	125	1968

Vehicle and engine types, equipment variants and national specifications not listed in these installation instructions have not been tested. However, installation according to these installation instructions may be possible.

The installation location of a digital timer and summer/winter switch should be confirmed with the end customer before installation.

Heater Unit/Installation Kit

Quantity	Description	Order No.:
1	Retail accessories with desired heater control	See price list
1	Installation kit for Audi A4 1.9 + 2.0 TDI Diesel	9015441A

Heater unit recommended for the respective vehicle class:

Vehicle	Heater unit
Compact car	Thermo Top E
Mid-size car, station wagon	Thermo Top C
Full-size car, van, offroader	Thermo Top P

The selection of the heater unit is based on the passenger compartment size of the vehicle and the level of comfort required by the customer!



Foreword

The installation instructions apply to the Audi A4 1.9 + 2.0 TDI vehicles with a Diesel engine
- For the validity, see page 2 - from model year 2006 and later, assuming technical modifications to the vehicle do not affect installation, any liability claims excluded. Depending on the vehicle version and equipment, modifications may be necessary during installation with respect to these installation instructions.

However, the stipulations in the "installation instructions" and "operating and maintenance instructions" for the *Thermo Top C/P/E* must always be observed.

The corresponding rules of technology and any information from the vehicle manufacturer should be observed during the installation work.

General Instructions

Installation should be carried out according to the general, standard rules of technology. Unless specified otherwise, fasten hoses, lines and wiring harnesses to original vehicle lines and wiring harnesses using cable ties.

Sharp edges should be fitted with edge protectors (split-open plastic hose).

Spray unfinished body areas, e.g. drilled holes, with anti-corrosion wax (Tectyl 100K, Order No. 111329).

Special Tools

- Torque wrench for 2.0 - 10 Nm
- Hose clamping pliers
- Metric thread-setter kit

Explanatory Notes on Document

To provide you with a quick overview of the individual working steps, you will find an identification mark on the outside top right corner of the page in question.

Mechanical system



Electrical system



Coolant connection



Fuel connection



Exhaust system

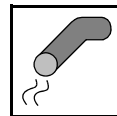

Combustion air



Special features are highlighted using the following symbols:



Specific risk of injury or fatal accidents.



Specific risk of damage to components.



Specific risk of fire or explosion.



Reference to general installation instructions of Webasto components or to the manufacturer's vehicle-specific documents.



Reference to a special technical feature.

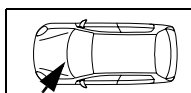
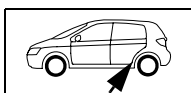

The arrow in the vehicle icon indicates the position on the vehicle and the viewing angle.

Preliminary Work

WARNING!

- Depressurize the cooling system.
- Copy the factory number from the original type label to the duplicate type label.
- Remove years that do not apply from the duplicate label.
- Attach the duplicate label (type label) in the appropriate place.
- Remove the coolant reservoir cap.
- Completely remove the battery.
- Remove the air filter together with the intake hose.
- Detach the engine control unit in the coolant reservoir.
- Open the fuel tank cap, ventilate the tank.
- Close the tank cap again.
- Remove the underride protection.
- Remove the underbody trim on the right.
- Remove the luggage compartment cover (only on sedan)
- Remove the complete lower plastic trim of the luggage compartment floor (only on Avant)
- Open the tank-fitting service lid
- Remove the fuel-tank sending unit in accordance with the manufacturers specifications.
- Remove the A/C control panel in accordance with the manufacturers specifications.
- Remove the instrument panel trim on the driver's side.

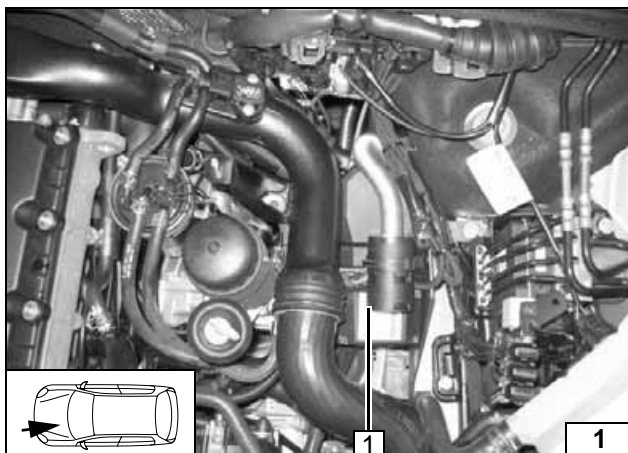

Heater unit installation location

1 Heater unit

Installation
location



Electrical Connections

Fuse holder, relay K3

- 2 K3 relay
- 3 Retaining plate for fuse holder
- 1 M5x12 bolt, washer, M5 nut
- 4 Fuse holder

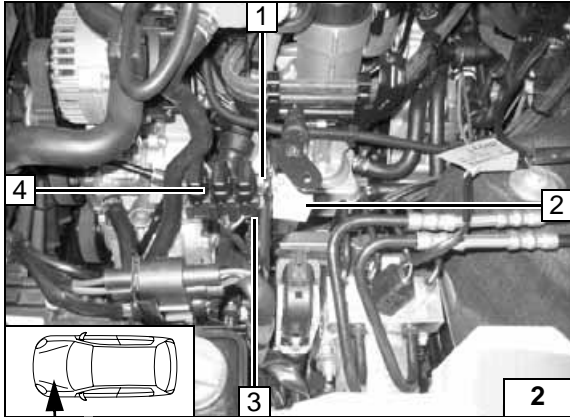

Positive and ground wire

Route positive wire 1 through rubber plug to battery.

- 3 Ground wire
- 2 Original vehicle ground support point

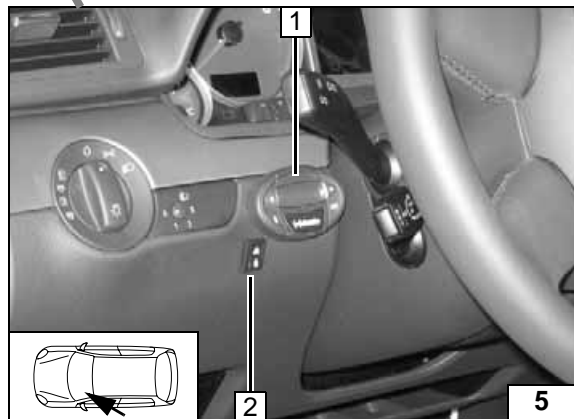
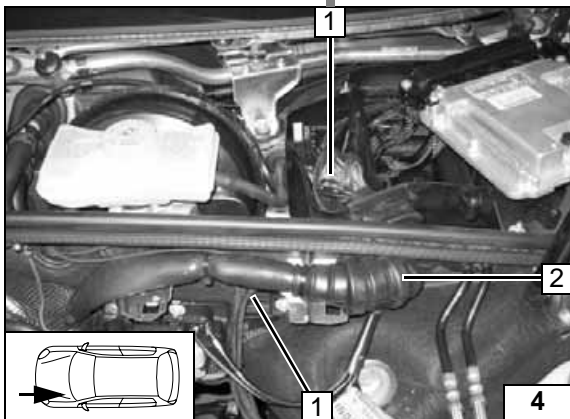
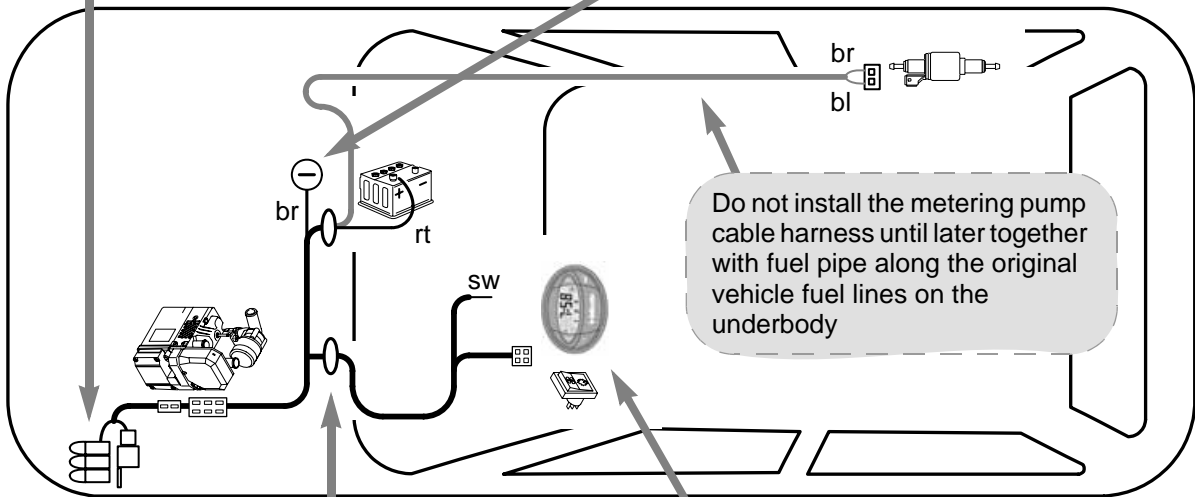
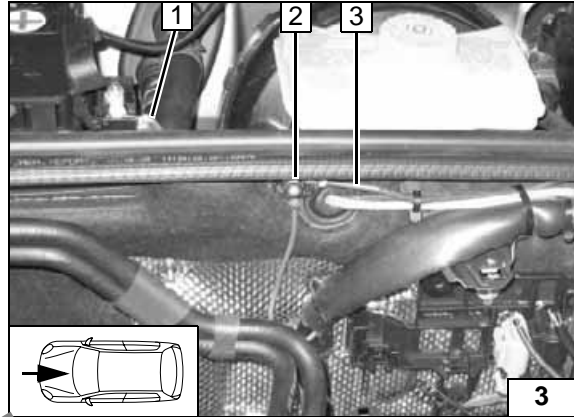

Wiring harness routing

Route wiring harnesses of digital timer and fan controller 1 through rubber plug 2 into control unit box and further under engine control unit into passenger compartment.

Digital timer and summer/winter switch option

- 1 Digital timer
- 2 Summer/winter switch, drilled hole 12 mm dia.



Wiring harness installation diagram

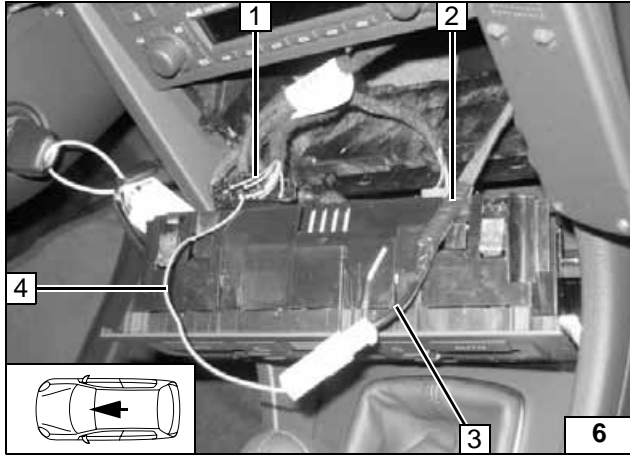

Fan controller

Connection on connector D of A/C control panel (use included microtimer). Produce connections as shown in wiring diagram.

- 1 Connector D
- 2 Insulate red (rt) wire to K3/87a and tie back
- 3 Black (sw) wire from K3/30
- 4 Green/white (gn/ws) wire on connector D Pin 10



Connecting air-conditioning control element

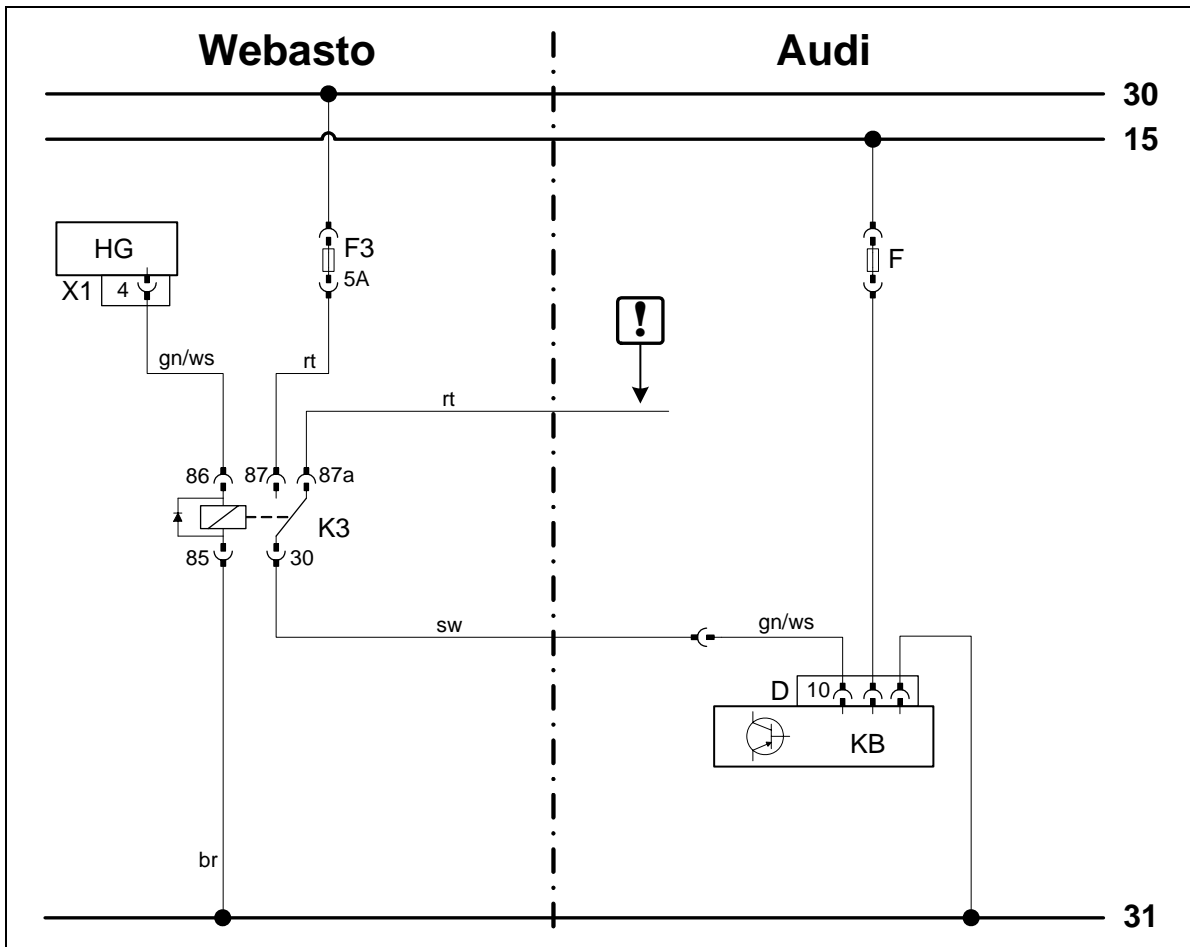

Automatic air-conditioning circuit diagram

Webasto components		Components of Audi A4 1.9 + 2.0 TDI		Colors and symbols	
HG	Heater unit TT-C/E	Fx	Fuse	rt	red
X1	6-pin heater unit connector	KB	Air-conditioning control panel	ws	white
F3	Fuse	D	Connector KB	sw	black
K3	Fan relay			br	brown
				gn	green
					Insulate wire ends and tie back
				X	Cutting point
				Wiring colors may vary.	

Legend

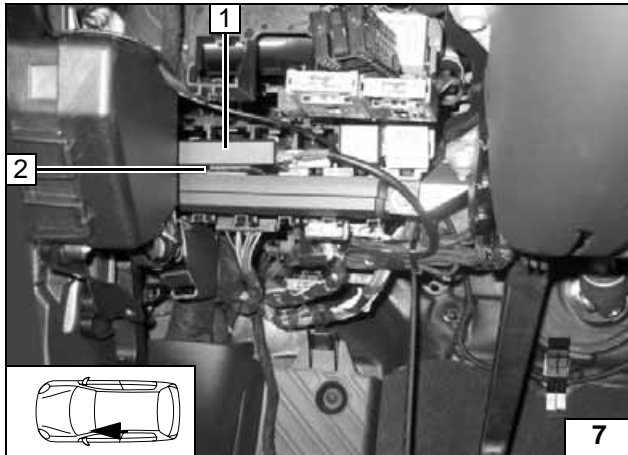

Remote option (Telestart)

- 1 Receiver
- 2 Double-sided Velcro strip (self-adhesive)



Installing receiver

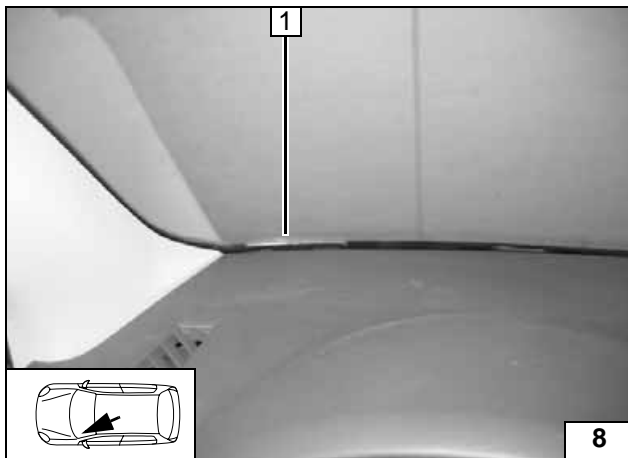

- 1 Antenna

Installing antenna

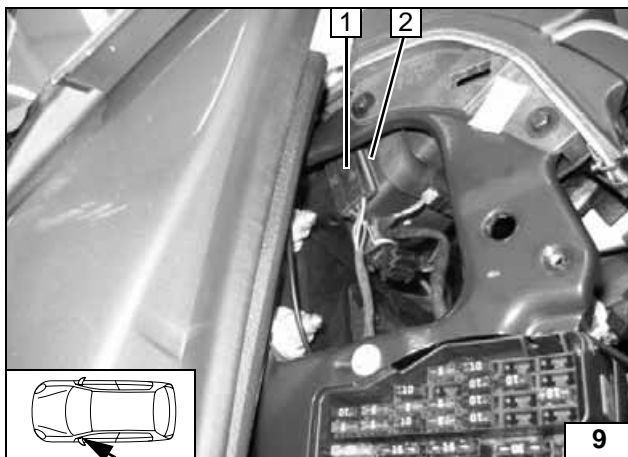

Temperature sensor for HTM100 only

- 1 Temperature sensor
- 2 Double-sided Velcro strip (self-adhesive)

Installing temperature sensor

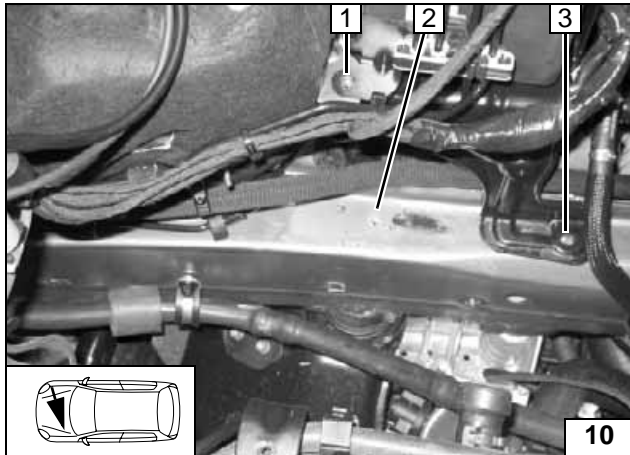
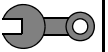

Preparing installation location

Remove original vehicle bolt at position **1** and **3** (will be reinstalled here later). Drill out hole at position **2**.

2 Drill 9.1 mm dia. hole; install rivet nut



Installing rivet nut

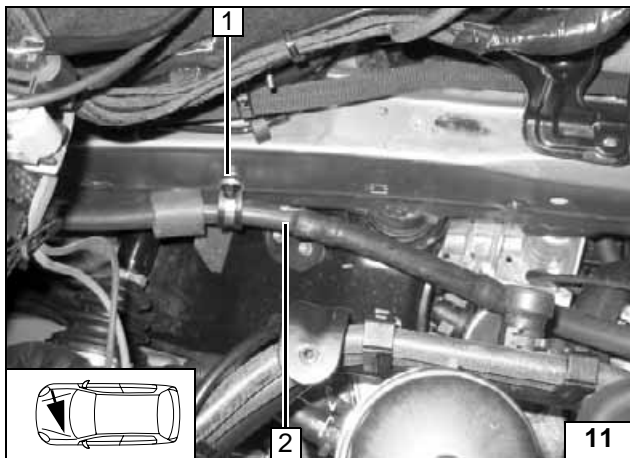

2 Servo hose

1 Rubber-coated p-clamp, plastic nut on existing stud bolt

Tying back servo hose

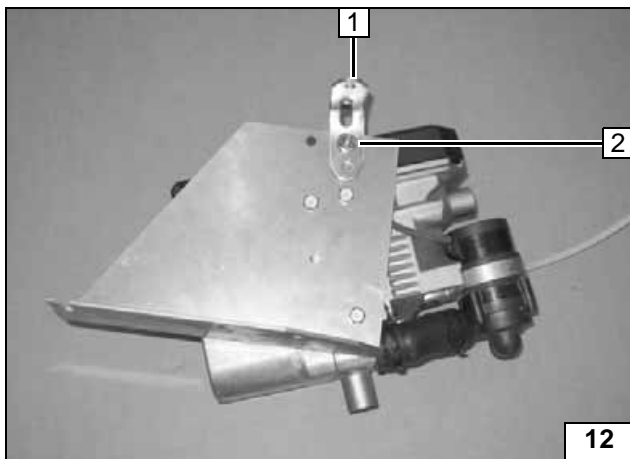

Preparing heater unit

Discard included angle bracket of bracket; will be replaced with perforated bracket. Angle down perforated bracket **1** by 90° in accordance with template and loosely premount.

2 M6x20 bolt, flanged nut



Loosely premounting perforated bracket on bracket

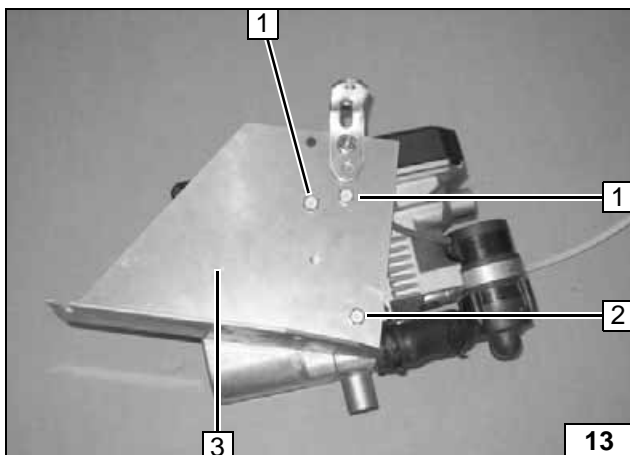

Insert two washers between heater unit and bracket **3** at position **2**.

Tighten E-JOT screws to 10 Nm!

1 E-jot screw [2x]

2 E-jot screw, washer [2x]



Installing bracket

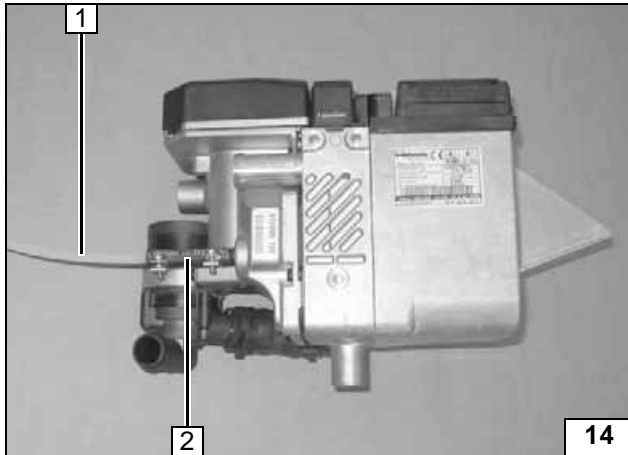
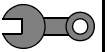

- 1 Mecanyl fuel line
- 2 Hose section, 10 mm dia. hose clamp [2x]

Premounting fuel line

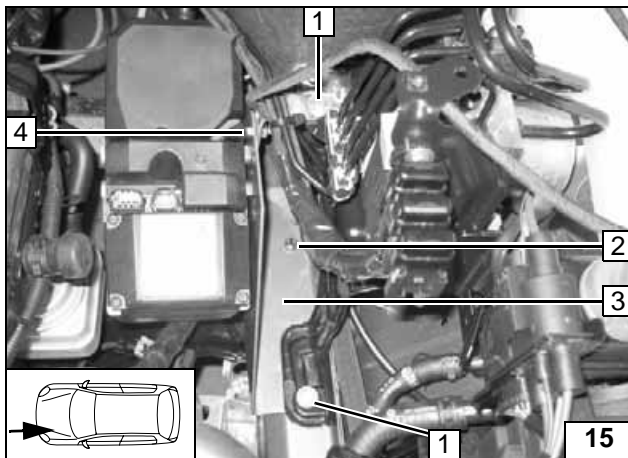

Installing heater unit

Insert bracket 3 with heater unit as shown. Tighten bolt at position 4.

- 1 Loosely mount original vehicle bolt [2x] in existing threaded hole.
- 2 M6x20 screw, spring lockwasher on premounted rivet nut



Installing heater unit

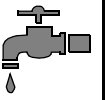

Coolant connection

WARNING!

Tighten all hose clamps to 2.0 + 0.5 Nm.

Any coolant running off should be collected using an appropriate container!

Install hoses so that they are kink-free. Unless specified otherwise, always fasten using cable ties.

Position hose clamps and spring band clamps so that no other hose can be damaged.

The connection should be "inline" based on the following diagram:

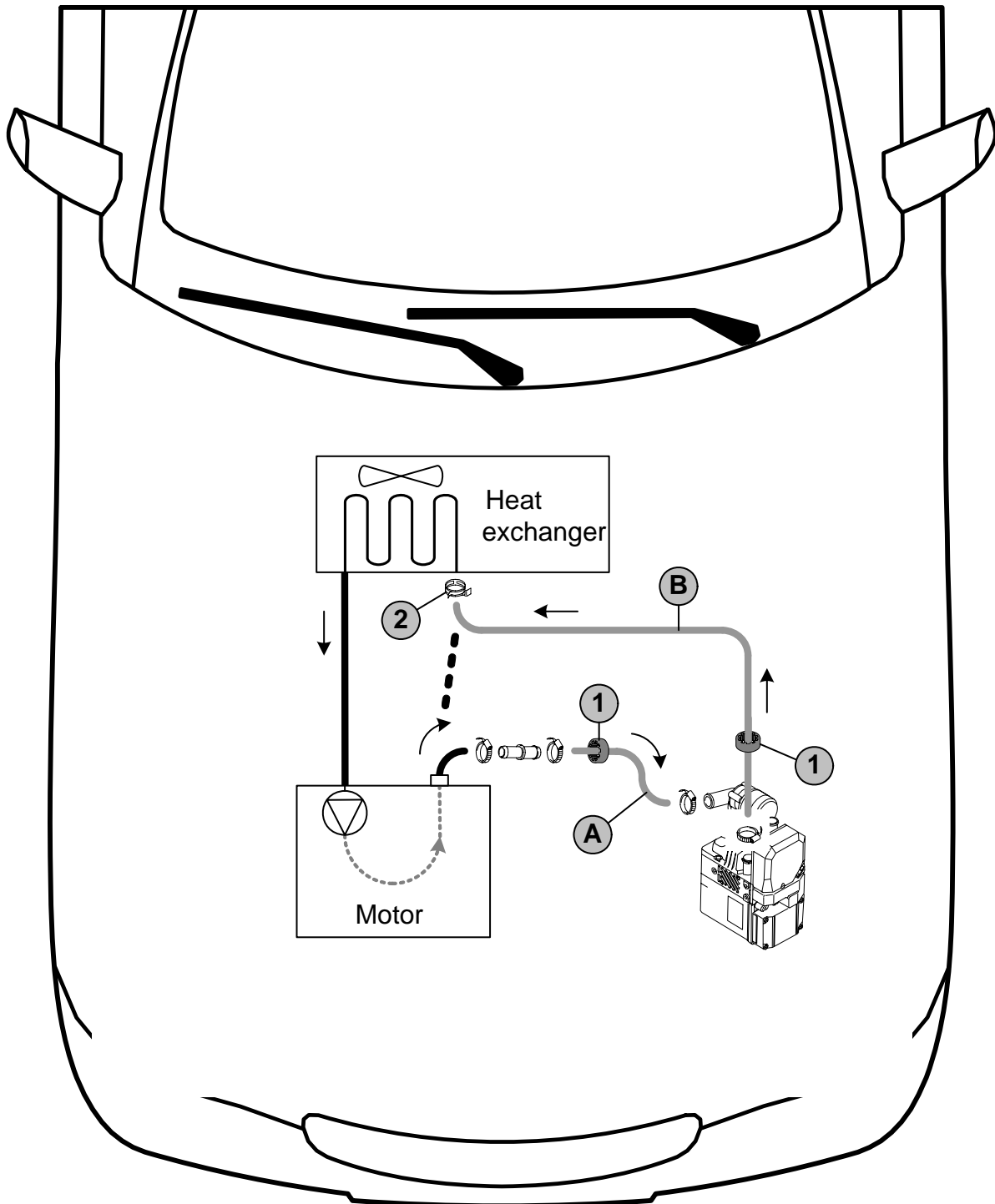

Coolant routing diagram

All hose clamps 20-27 mm dia.! Connecting pipe = dia. 20x20!
 Position 1 = Black rubber isolator! Position 2 = Original vehicle spring clip!



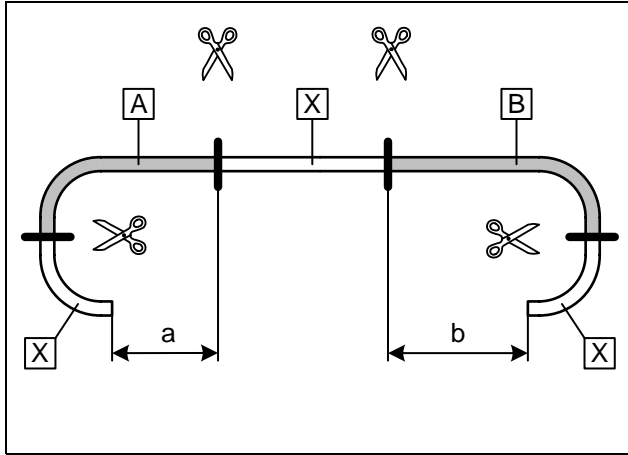

a = 270 mm
b = 530 mm

Discard sections X

Cutting coolant hoses to length

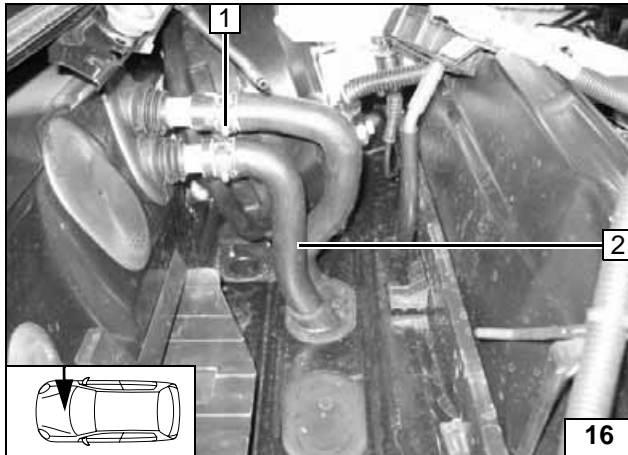

Remove original vehicle hose from engine outlet to heat exchanger inlet **2** (spring clip **1** will be reused).



Removing coolant hose

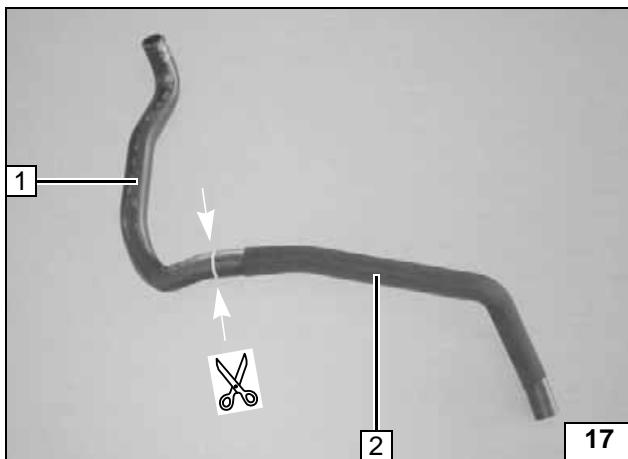

Cut away protective hose **2** in area of cutting point.

- 2** Engine outlet hose section
- 1** Discard hose section



Cutting off coolant hose

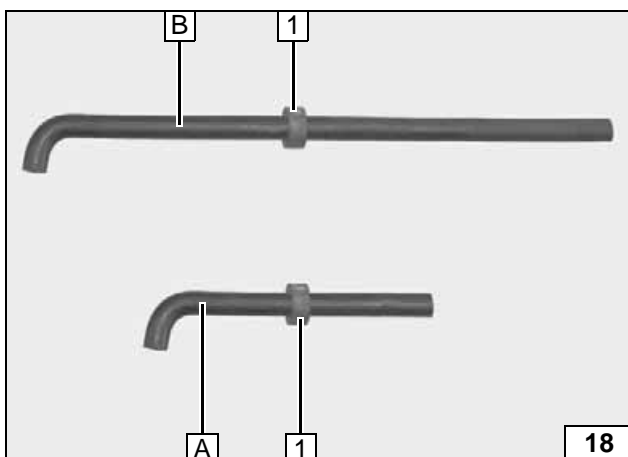

- 1** Push on black (sw) rubber isolator [2x]
- 2** Engine outlet hose section

Preparing hoses

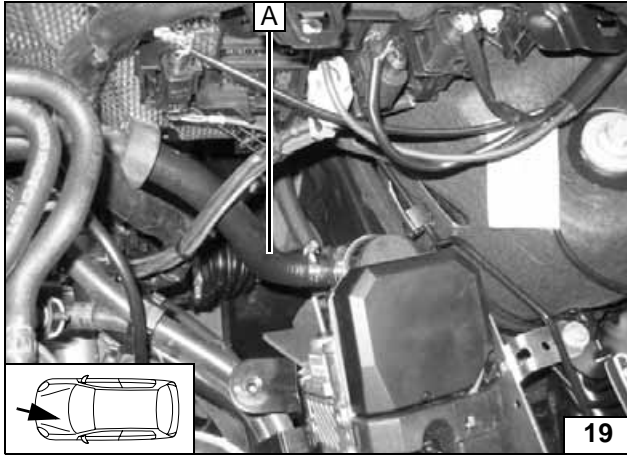

19

Conne-
tion to
heater unit
inlet

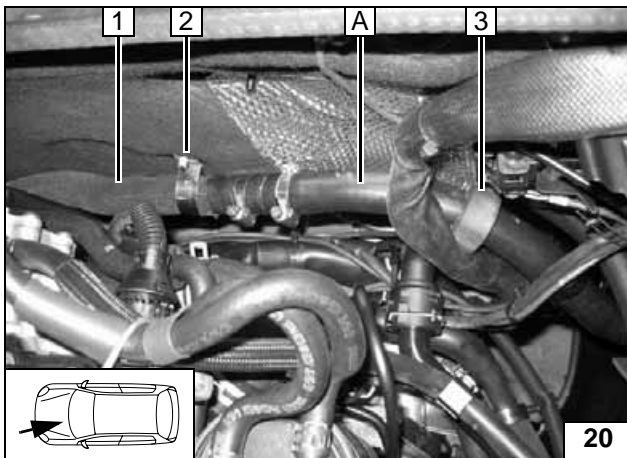

20

Fasten hose **A** on engine outlet. Fasten hose **A** on stud bolt **2** again with original vehicle hose clamp.

3 Align black (sw) rubber isolator on wiring harness

Conne-
tion to
heater unit
inlet

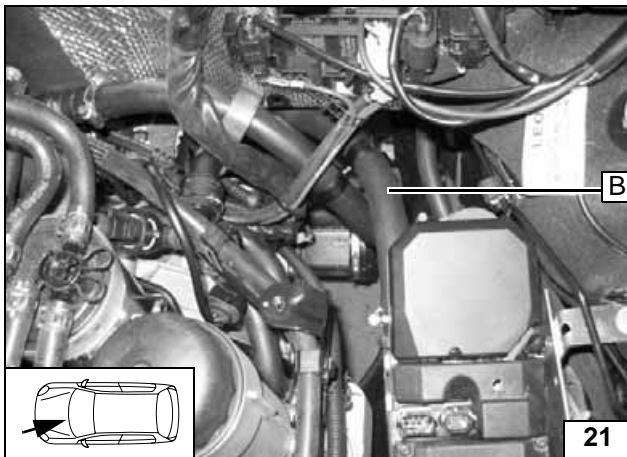

21

Conne-
tion to
heater unit
outlet

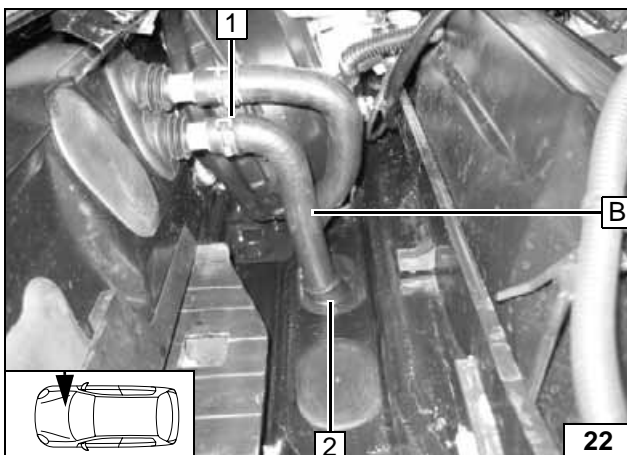

22

Route hose **B** through original vehicle rubber plug **2** into coolant reservoir. Before connecting, fill the coolant hoses with coolant.

1 Original vehicle spring clip



Conne-
tion to heat
exchanger
inlet

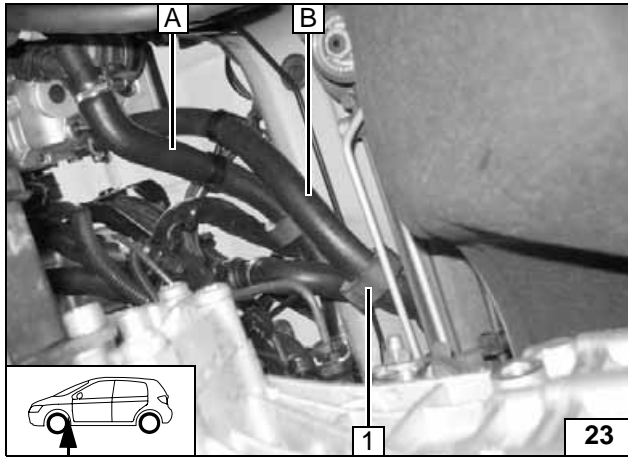

1 Align black (sw) rubber isolator as shown

Conne-
ction to
heater unit
outlet

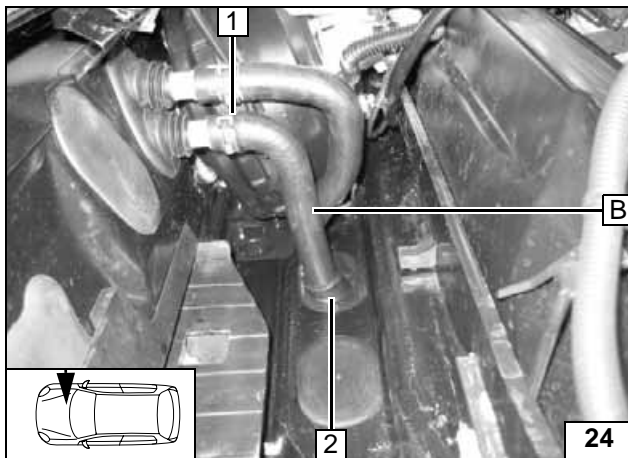

Route hose **B** through original vehicle rubber plug **2** into coolant reservoir. Before connecting, fill the coolant hoses with coolant.



1 Original vehicle spring clip

Conne-
ction to heat
exchanger
inlet

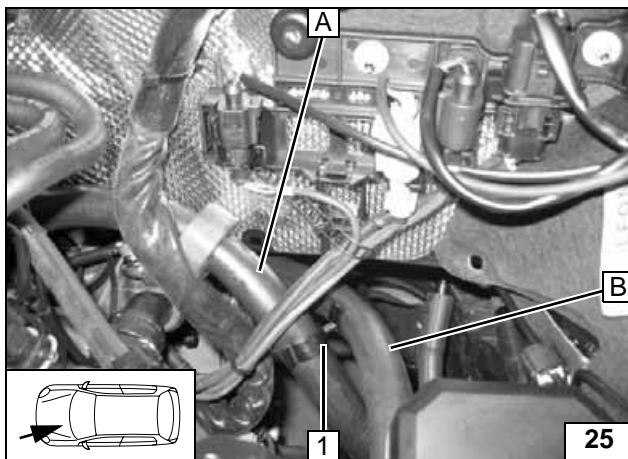

1 Spacer bracket

Install-
ing
spacer
bracket

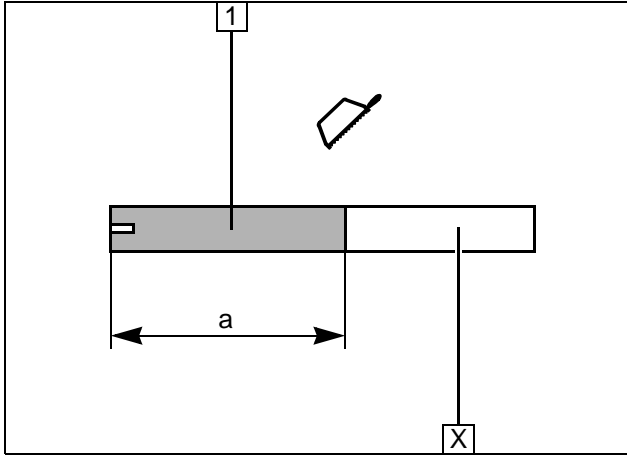
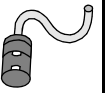

Combustion air

- 1 Combustion air pipe
a = 250 mm

Discard section X

Cutting combustion air pipe to length

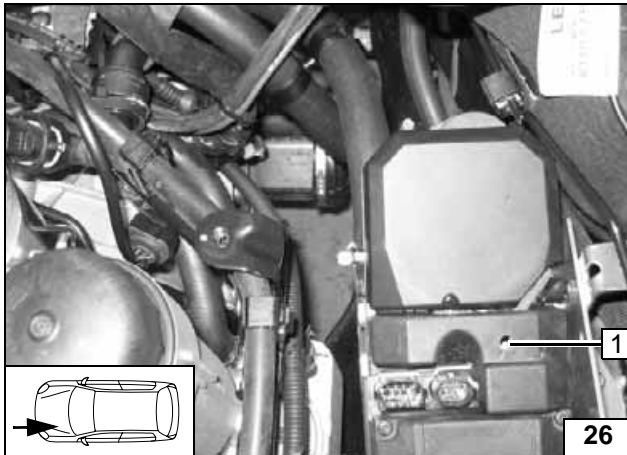

Punch through perforation in heater unit lid at position 1 and insert retaining clip.



Inserting retaining clip

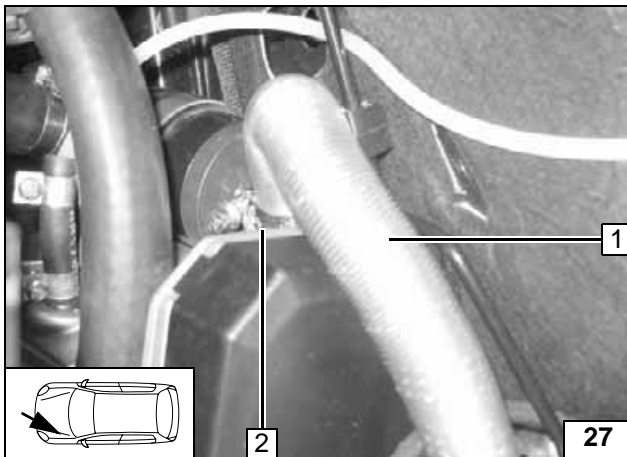

- 1 Combustion-air intake pipe
- 2 27 mm dia. hose clamp

Installing intake pipe

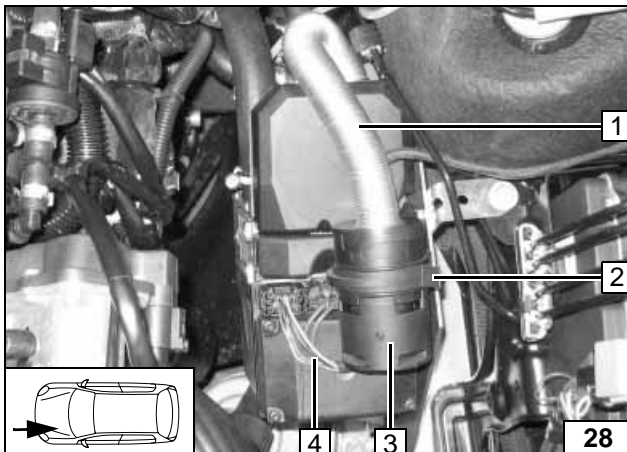

Connect wiring harness 4 to heater unit.

- 1 Combustion-air intake pipe
- 3 Combustion-air intake muffler
- 2 Retaining clip in hole



Installing muffler



Fuel Connection

CAUTION!

Open the vehicle's fuel tank cap, ventilate the tank and then re-close the tank lock.

Catch any fuel running off with an appropriate container.

Install fuel line and metering-pump wiring harness so that they are protected against stone impact. Unless specified otherwise, always fasten using cable ties.

Mount the fuel line and wiring harness with rub protection on sharp edges.

WARNING!

The fuel line and wiring harness are routed to the metering pump in as shown in the wiring harness routing diagram.

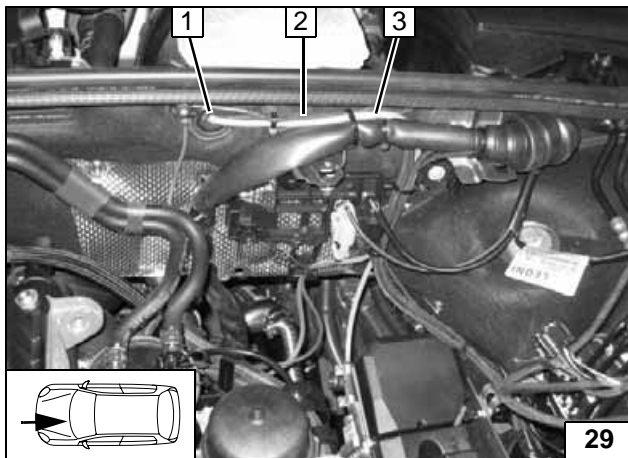

Route wiring harness of metering pump 2 and Mecanyl fuel line 3 through rubber plug 1 in coolant reservoir to right-hand side of vehicle.



Installing lines

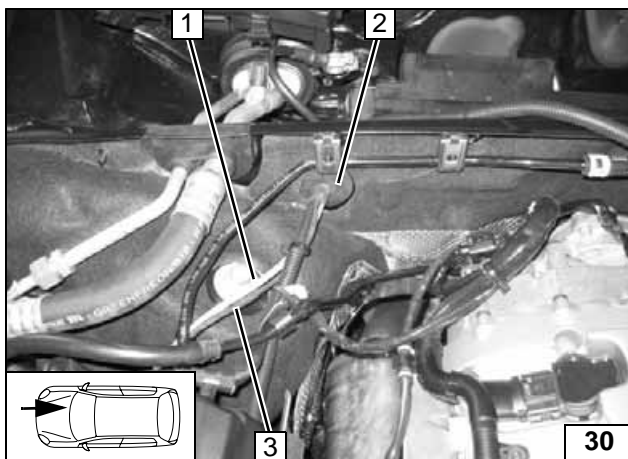

Route wiring harness of metering pump 3 and Mecanyl fuel line 1 from coolant reservoir through rubber plug 2 along original vehicle fuel lines to underbody.



Installing lines

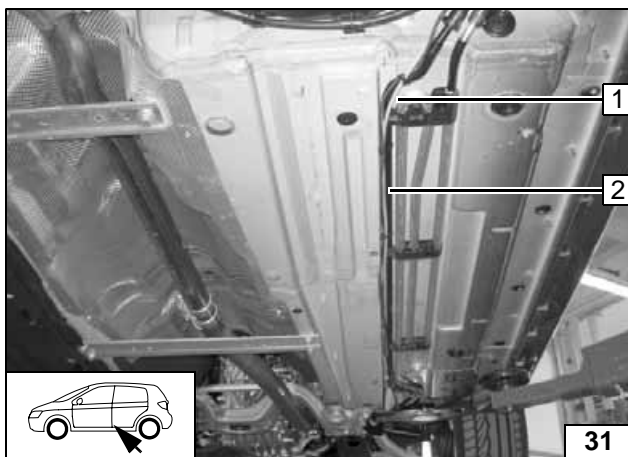

Route wiring harness of metering pump 2 and Mecanyl fuel line 1 along original vehicle fuel lines to installation location of metering pump.



Installing lines

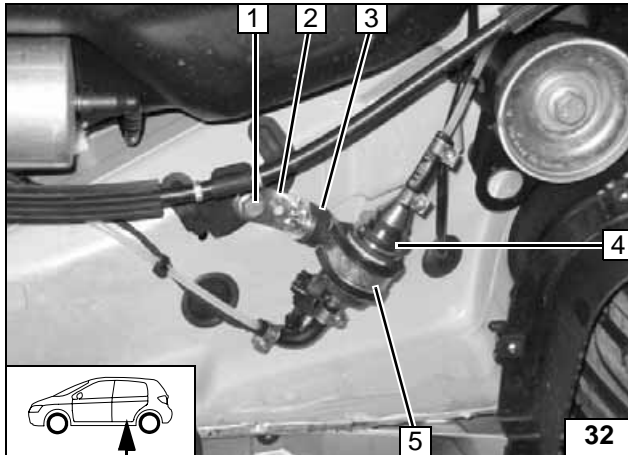

Ensure proper installation position of metering pump 4, see "Installation Instructions".
Installation location on right next to vehicle fuel tank.

- 2 Angle bracket
- 1 Original vehicle bolt
- 5 Rubber-coated pipe clamp
- 3 Silent block, flanged nut [2x] on angle bracket



Installation location of metering pump

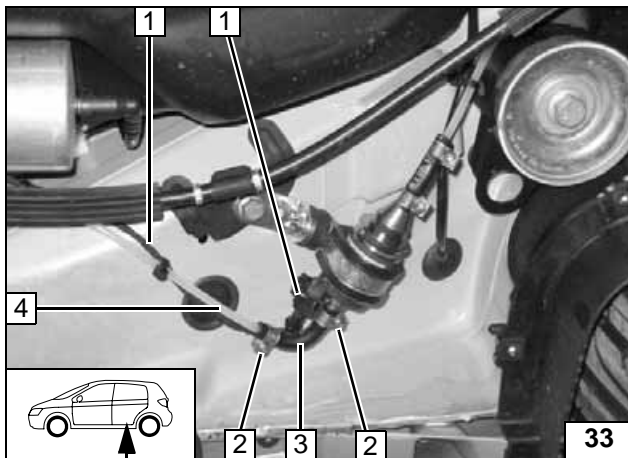

Fuel line from heater unit 4 on pressure side of metering pump [side with connector].

- 3 90° molded hose, 10 mm dia. hose clamp [10x]
- 2 10 mm dia. hose clamp [2x]
- 1 Wiring harness of metering pump, single-wire seal, tab connector, connector housing



Connecting metering pump

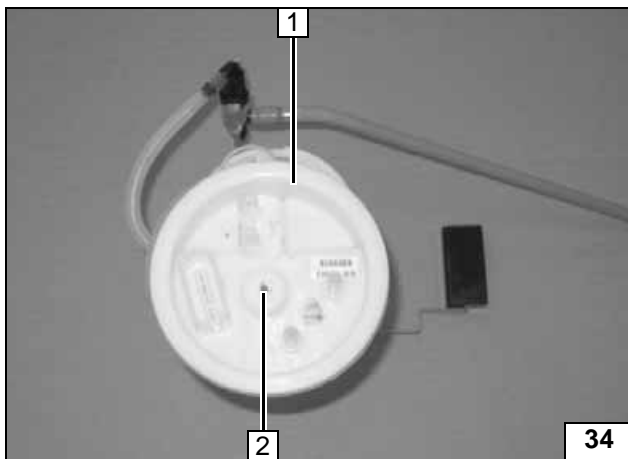

Remove fuel-tank sending unit 1 in accordance with manufacturer's specifications.
6 mm dia. hole at position 2 in center of cut-out!



Removing fuel

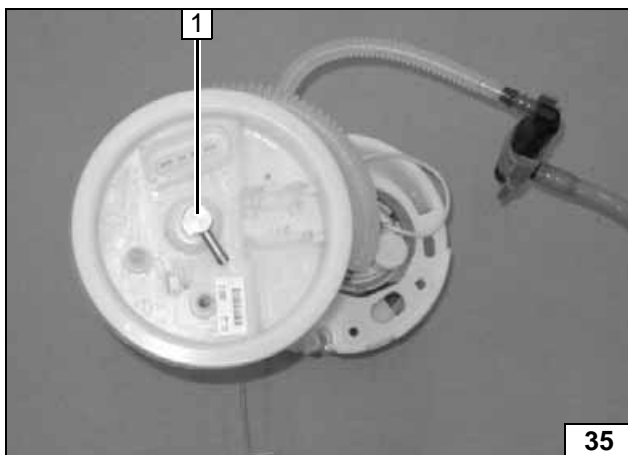

- 1 Fuel standpipe

Installing fuel standpipe

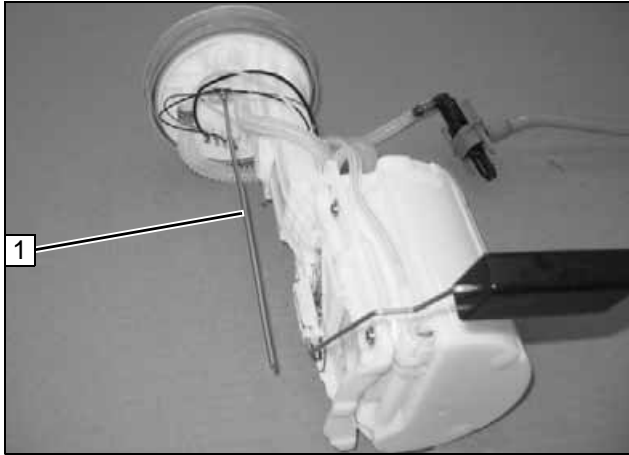

Cut fuel standpipe to length in accordance with template.

- 1 Fuel standpipe

Installing fuel standpipe

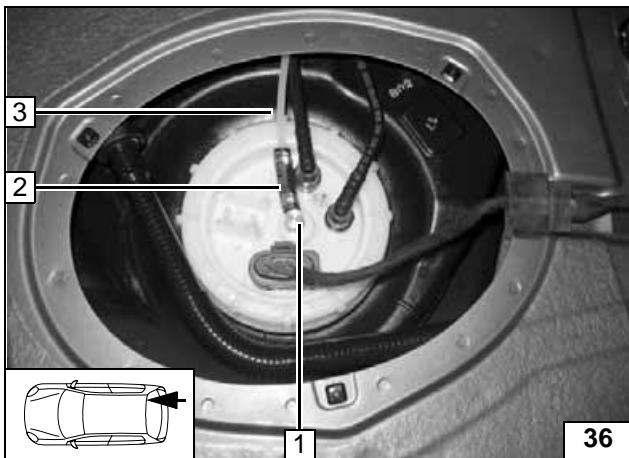

Install fuel-tank sending unit according to manufacturer's specifications. Ensure freedom of movement of fuel sensor.

- 1 Fuel standpipe
- 3 Additional Mecanyl line
- 2 Hose section, 10 mm dia. Caillau clamp [2x]



Connecting fuel line

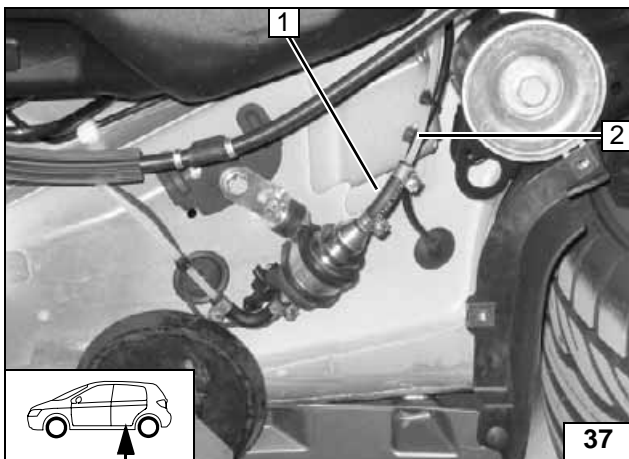

Fuel line from fuel standpipe **2** on intake side of metering pump [side without connector]. Check the position of the components; adjust if necessary. Check that they have free clearance.

- 1 Hose section, 10 mm dia. hose clamp [2x]



Connection to metering pump

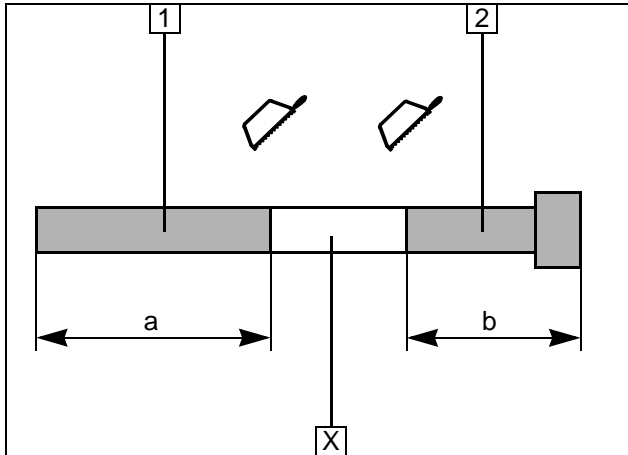
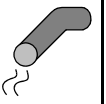

Exhaust system

- 1 Exhaust pipe
a = 380 mm
- 2 Exhaust end section
b = 140 mm

Discard section X

Preparing
exhaust
pipe

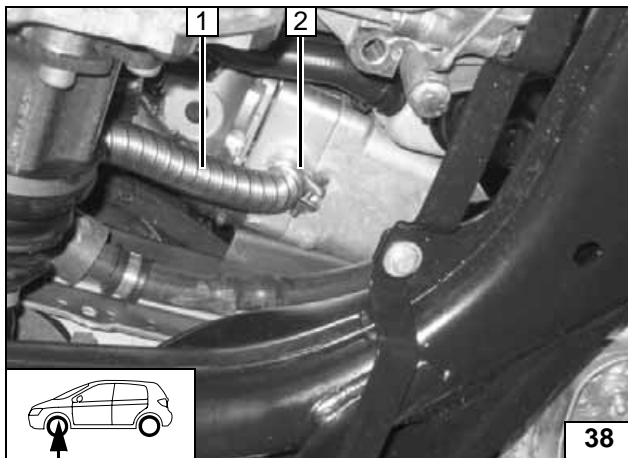

Photo shows vehicle with manual transmission!

- 1 Exhaust pipe
- 2 Hose clamp



Installing
exhaust
pipe

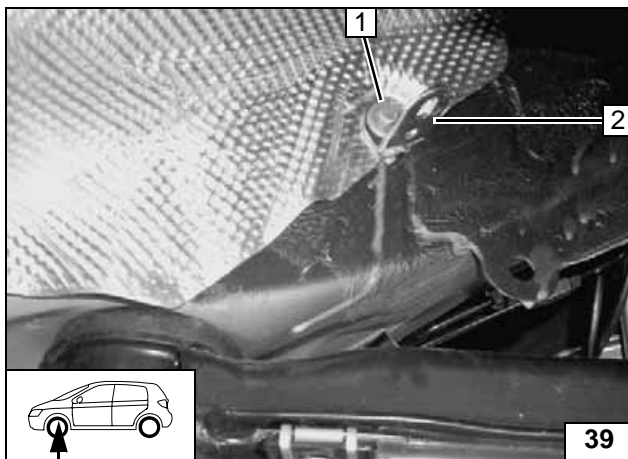

Photo shows vehicle with manual transmission!

- 2 Angle bracket
- 1 Original vehicle bolt



Installing
angle
bracket

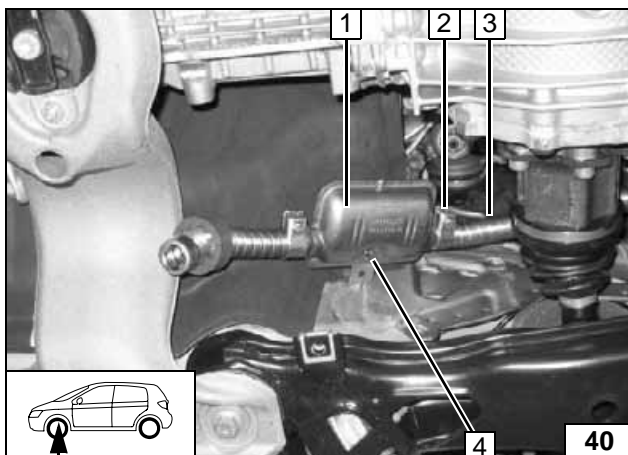

Photo shows vehicle with manual transmission!

- 2 Exhaust pipe
- 1 Exhaust muffer
- 2 Hose clamp
- 4 M6x20 bolt, large diameter washer,
flanged nut on angle bracket



Installing
muffer

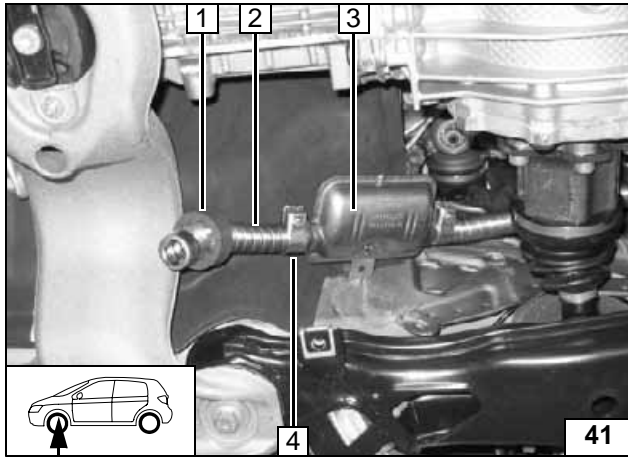
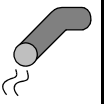

Photo shows vehicle with manual transmission!

- 3 Exhaust muffler
- 2 Exhaust end section
- 4 Hose clamp
- 1 Red (rt) rubber isolator



Installing exhaust end section

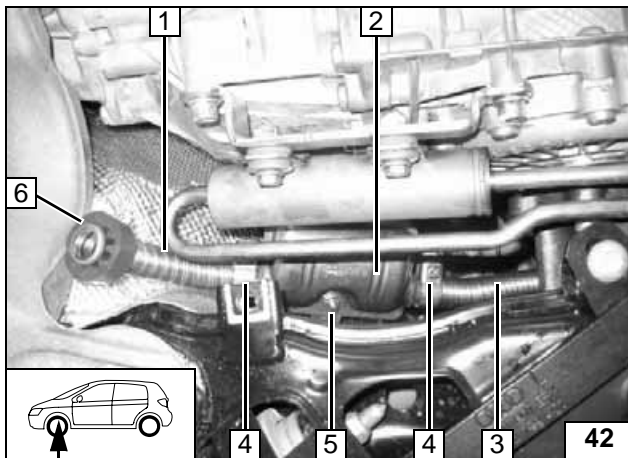
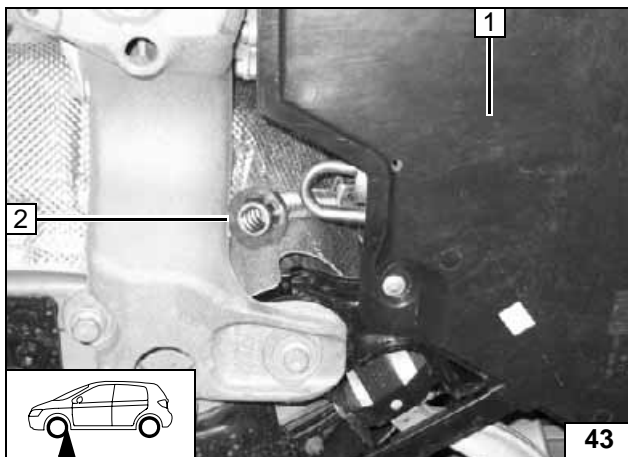

Photo informative; shows vehicle with automatic transmission!

- 2 Exhaust muffler
- 5 M6x20 bolt, flanged nut on angle bracket
- 3 Exhaust pipe
- 1 Exhaust end section
- 4 Hose clamp [2x]
- 6 Push on red (rt) rubber isolator



Installing exhaust system



Mount underdrive protection 1.

- 2 Position red (rt) rubber isolator

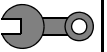

Mounting underdrive protection

**Final Work****WARNING!**

Reassemble the disassembled components in reverse order.

Check all hoses, hose, spring and Caillau clamps, as well as all electrical connections for firm seating.

Secure all loose cables using cable ties.

Only use manufacturer-approved coolant.

Spray the heater unit components with anti-corrosion wax (Tectyl 100K, Order No. 111329).

- Connect the battery
- Start the engine, bleed the coolant circuit according to the vehicle manufacturer's instructions and top up coolant
- Set the digital timer.
- Set the manual air conditioning or automatic air conditioning according to the "operating instructions for the end customer".
- Check the proper operation of the additional heater, see the operating instructions/installation instructions.
- Attach the "Switch off additional heater before refueling" sticker to the left-hand B-pillar.

**Webasto***Feel the drive*

Webasto AG
Postfach 80 - 82132 Stockdorf, Germany - Hotline +49-
(0)1805-932278
Hotfax +49-(0)395-5592-353 - <http://www.webasto.de>

Operating Instructions for End Customer

Please remove page and add to the vehicle operating instructions.



Before parking the vehicle, make the following settings:



1 Set temperature to „HI“

For vehicles with automatic air conditioning

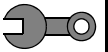

Template for Perforated Fastening Strap

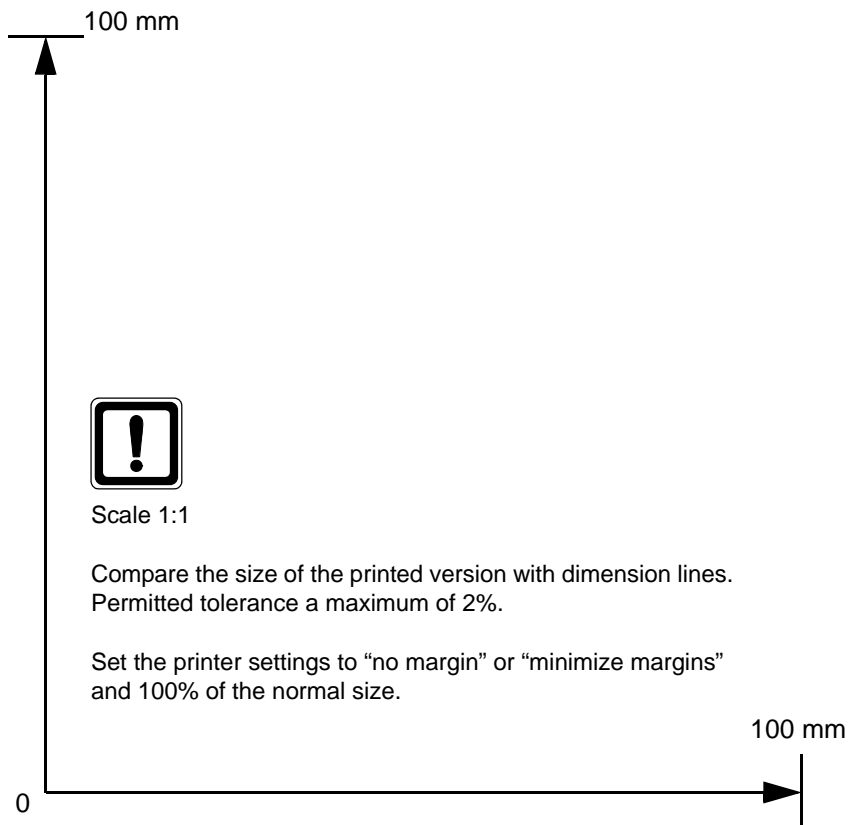
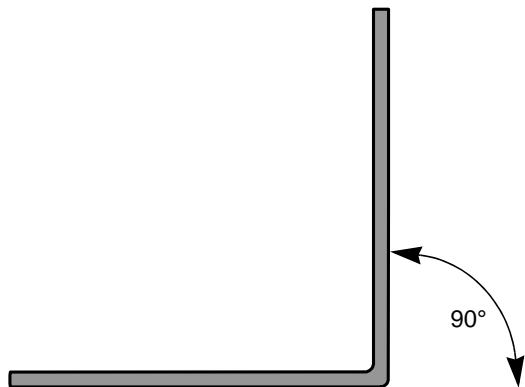
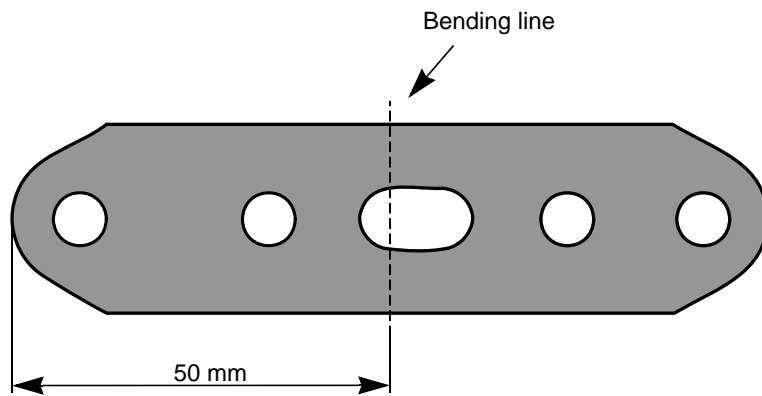

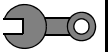

Template for Fuel Standpipe

