

Water Heater Unit



Thermo Top C Additional Heater e1 00 0002

Thermo Top P Additional Heater e1 00 0104

Installation Instructions

Opel Antara

Diesel
from Model Year 2007
Left-hand drive vehicle
Automatic transmission



WARNING!

Hazard warning:

Incorrect installation or repair of Webasto heating systems may cause a fire or result in the emission of carbon monoxide, which can be fatal. Serious or fatal injuries can be caused as a result.

Specialist company training, technical documentation, specialized tools and equipment are required to install and repair Webasto heating and cooling systems.

NEVER attempt to install or repair Webasto heating or cooling systems if you have not successfully completed the company training and thereby acquired the required technical skills, or if you do not have access to the required technical documentation, tools and equipment needed to carry out correct installation and repairs.

ALWAYS follow all Webasto installation and repair instructions and observe all warnings.

Webasto does not accept any liability for defects and damage that are attributable to installation by untrained staff.

Table of Contents

Validity	2	Coolant connection diagram	14
Heater Unit/Installation Kit	3	Preparing heater unit	15
Foreword	3	Preparing installation location	17
General Instructions	3	Installing heater unit	18
Special Tools	3	Coolant connection	19
Explanatory Notes on Document	4	Fuel Connection	21
Preliminary Work	5	Combustion air	23
Heater unit installation location	5	Exhaust system	24
Electrical Connections	6	Operating Instructions for End Customer	27
Fan controller for manual air conditioning	7		
Automatic air-conditioning fan controller	9		
Remote option (Telestart)	12		
Remote option (Thermo Call)	13		

Validity

Manufacturer	Model	Type	EG-BE No./ABE
Opel	Antara	L-A	e1 * 2001 / 116 * 0118

Engine type	Engine model	Output in kW	Displacement in cm ³
Z20S	Diesel	110	1991

Vehicle and engine types, equipment variants and national specifications not listed in these installation instructions have not been tested. However, installation according to these installation instructions may be possible.

The installation location of a digital timer and summer/winter switch should be confirmed with the end customer before installation.

Heater Unit/Installation Kit

Quantity	Description	Order No.:
1	Opel-specific heater unit delivery scope	See price list
1	Installation kit for Opel Antara Diesel (basic kit)	1311919A
1	Additional kit for Opel Antara Diesel with Automatic Transmission	1311921A

Optional heater control:

Quantity	Description	Order No.:
1	Heater control	See Opel price list

Also required with automatic air-conditioning:

Quantity	Description	Order No.:
1	Kit for Opel Antara with Automatic Air-Conditioning	1311923A



Heater unit recommended for the respective vehicle class:

Vehicle	Heater unit
Compact car	Thermo Top E
Mid-size car, station wagon	Thermo Top C
Full-size car, van, offroader	Thermo Top P

The selection of the heater unit is based on the passenger compartment size of the vehicle and the level of comfort required by the customer!

Foreword

These installation instructions apply to Opel Antara Diesel vehicles with an automatic transmission - for validity, see page 2 - from model year 2007 and later, assuming technical modifications to the vehicle do not affect installation, any liability claims excluded. Depending on the vehicle version and equipment, modifications may be necessary during installation with respect to these installation instructions.

However, the stipulations in the "installation instructions" and "operating and maintenance instructions" for the *Thermo Top C/P/E* must always be observed.

The corresponding rules of technology and any information from the vehicle manufacturer should be observed during the installation work.

General Instructions

Installation should be carried out according to the general, standard rules of technology. Unless specified otherwise, fasten hoses, lines and wiring harnesses to original vehicle lines and wiring harnesses using cable ties.

Sharp edges should be fitted with edge protectors (split-open plastic hose).

Spray unfinished body areas, e.g. drilled holes, with anti-corrosion wax (Tectyl 100K, Order No. 111329).

Special Tools

- Torque wrench for 2.0 - 10 Nm
- Hose clamping pliers
- Metric Thread-Setter Kit

Explanatory Notes on Document

To provide you with a quick overview of the individual working steps, you will find an identification mark on the outside top right corner of the page in question.

Mechanical system

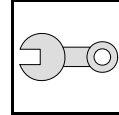

Electrical system

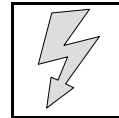

Coolant connection

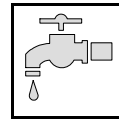

Fuel connection

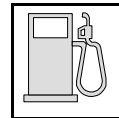

Exhaust system

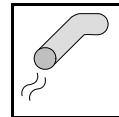

Combustion air

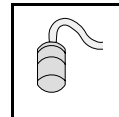

Special features are highlighted using the following symbols:



Specific risk of injury or fatal accidents.



Specific risk of damage to components.



Specific risk of fire or explosion.



Reference to general installation instructions of Webasto components or to the manufacturer's vehicle-specific documents.



Reference to a special technical feature.

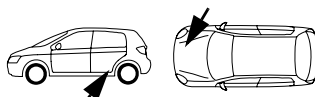

The arrow in the vehicle icon indicates the position on the vehicle and the viewing angle.

Preliminary Work

WARNING!

- Disconnect the battery "earth" or "ground" connection.
- Depressurize the cooling system.
- Copy the factory number from the original type label to the duplicate type label.
- Remove years that do not apply from the duplicate label.
- Attach the duplicate label (type label) in the appropriate place.
- Completely remove the battery
- Remove the fuse and relay box
- Remove the engine cover
- Remove the engine control unit
- Disconnect the power-steering fluid reservoir
- Disconnect the expansion tank
- Remove the charge-air tube between the air filter and the turbocharger
- Disconnect the air hose from the charge-air tube to the engine at the engine
- Remove the filler neck of the window washer system
- Remove the vent line at the top to the coolant expansion tank
- Open the fuel tank cap, ventilate the tank.
- Close the tank cap again.
- Remove the underride protection
- Open the left tank mounting service lid
- Remove the A/C control panel according to the manufacturer's instructions (only with manual air-conditioning)
- Remove the glove compartment (only with automatic air-conditioning)

Remove page 27 "Operating Instructions for End Customer" and insert with vehicle operating instructions.

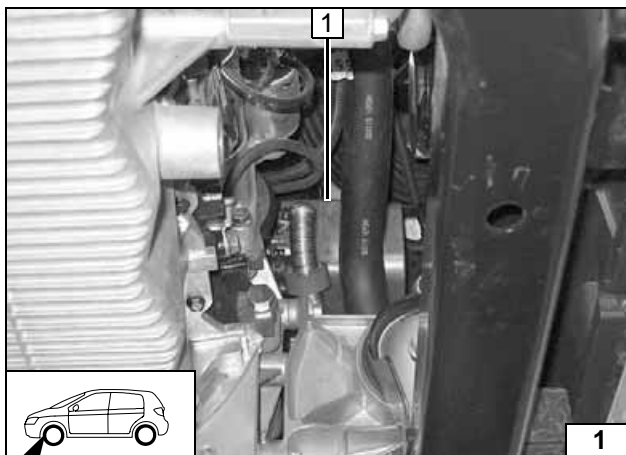

Heater unit installation location

Picture shows vehicle without automatic transmission!

1 Heater unit



Installation location



Electrical Connections

Wiring harness pass through

- 1 Protective rubber plug

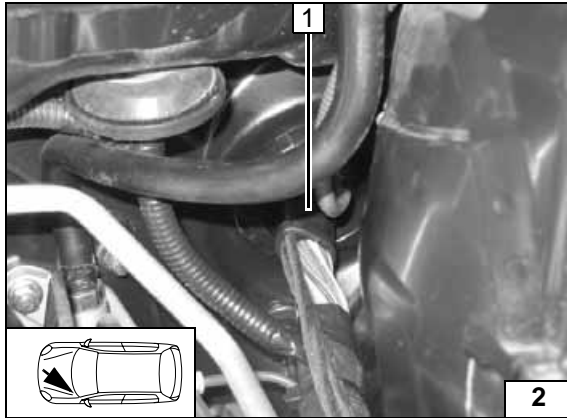

Digital timer

- 1 Digital timer

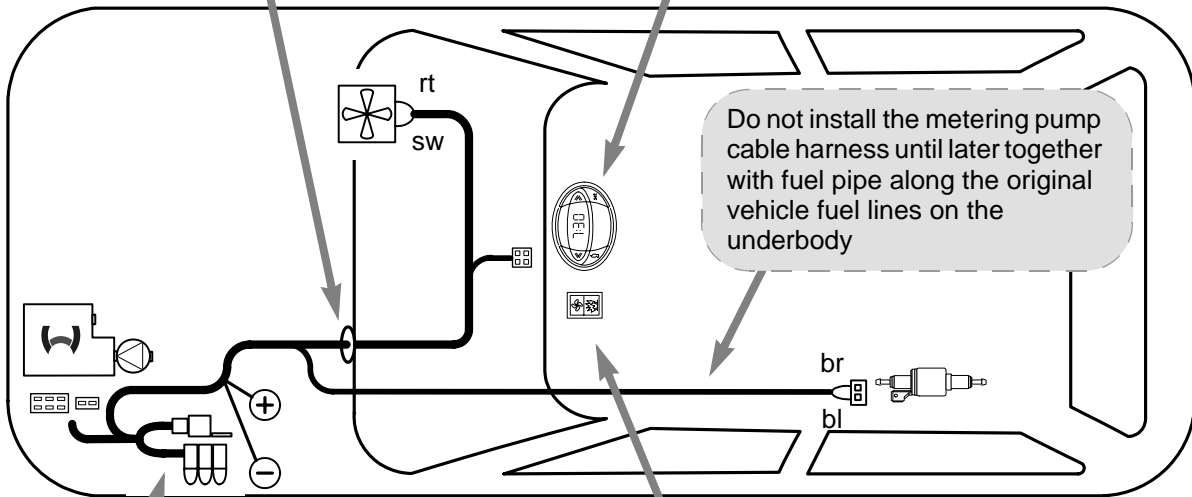
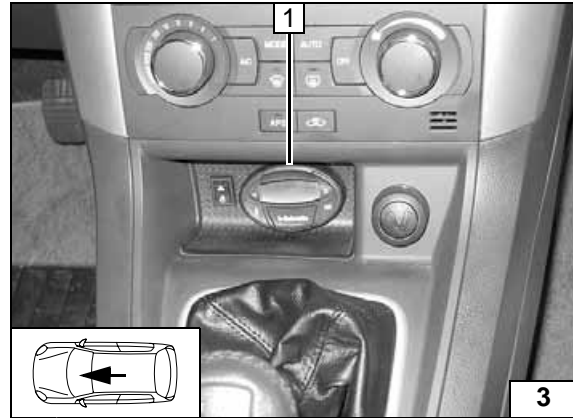

Wiring harness installation diagram

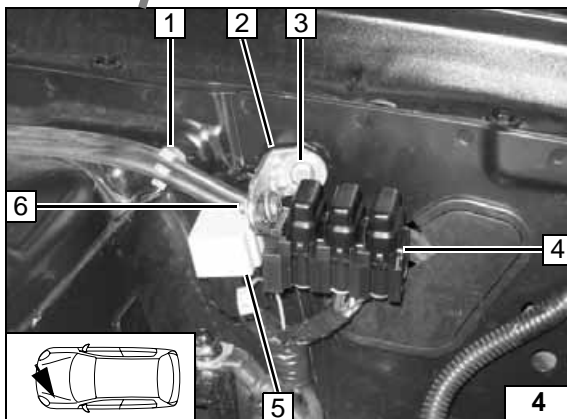

Fuse holder, relay K3

- 1 Move original vehicle clip
- 2 Angle bracket
- 3 Drill out hole to 9 mm dia., mount M6 rivet nut, M6x20 bolt, spring lockwasher
- 4 Fuse holder
- 5 K3 relay
- 6 Align M5x16 bolt, large diameter washer, M5 flanged nut to right in oblong hole

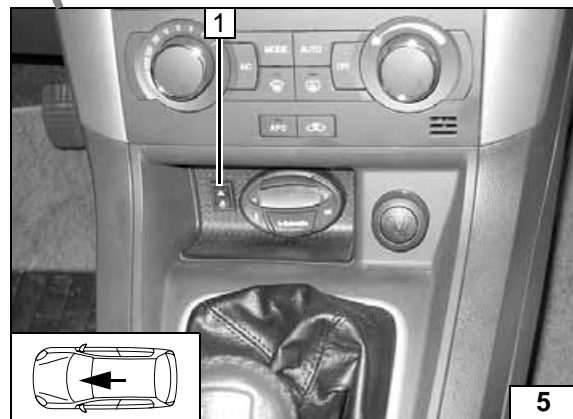

Summer/winter switch option

- 1 Summer/winter switch, drilled hole 12 mm dia.



Fan controller for manual air conditioning

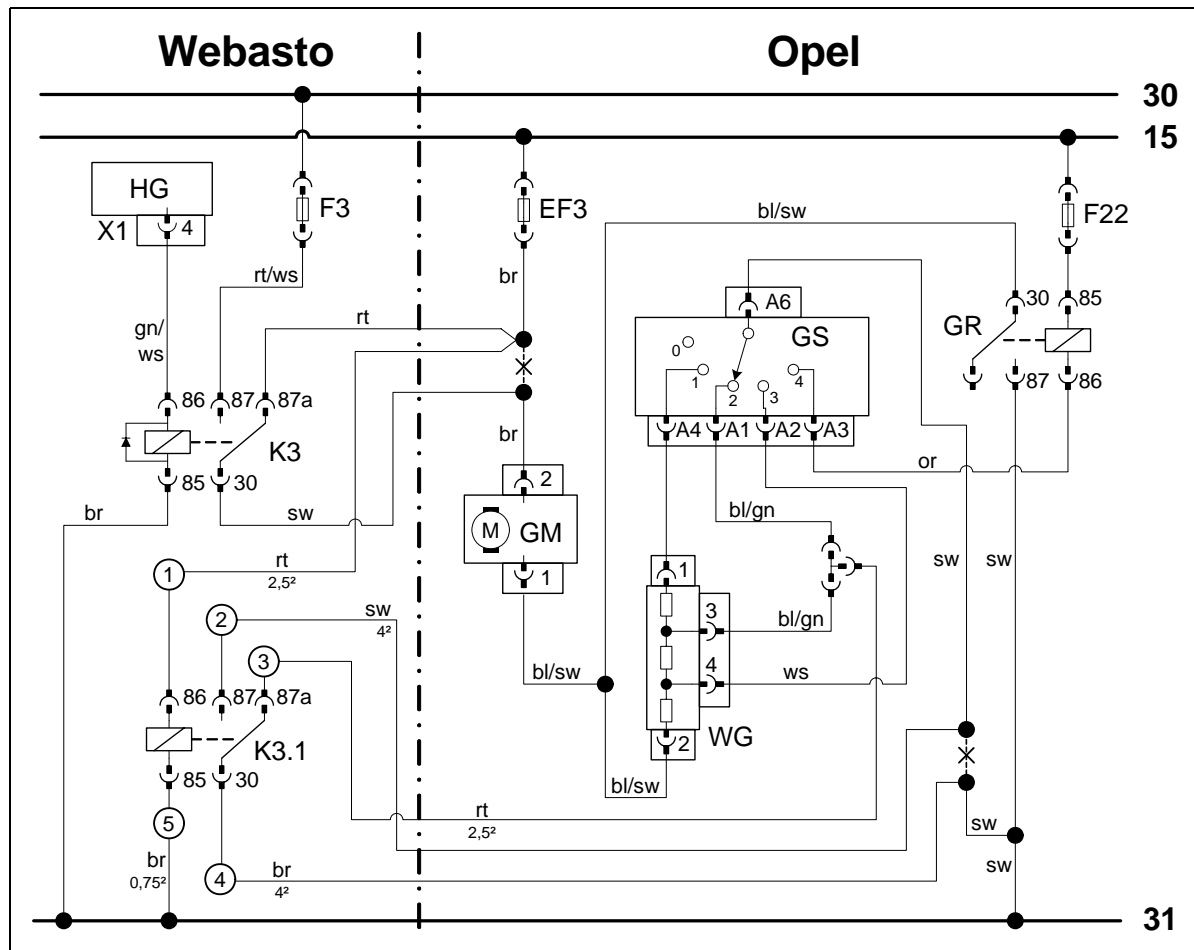

Wiring diagram for manual air conditioning

Webasto components		Components of Opel Antara		Colors and symbols	
HG	Heater unit TT-C/E	GM	Fan motor	rt	red
X1	6-pin connector	GS	Fan switch	ws	white
F3	Fuse, 25 A	EF3	40 A fan fuse	sw	black
K3	Fan relay	WG	Resistor group	br	brown
K3.1	Additional relay	GR	Fan relay	gn	green
				bl	blue
				or	orange
				X	Cutting point
				Wiring colors may vary.	

Legend

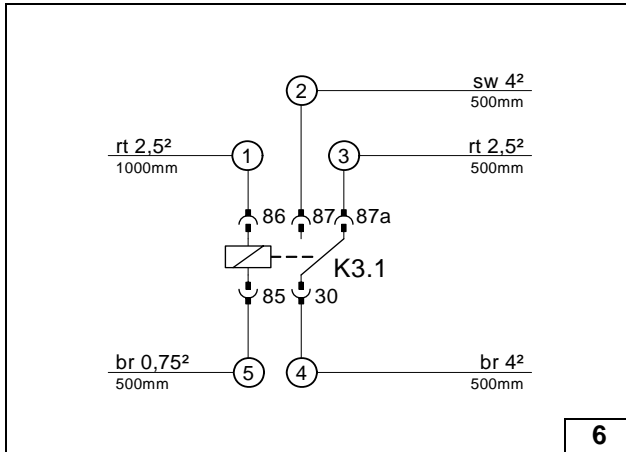

Preparing electrical system

Produce connections as shown in wiring diagram.
Cut 500 mm off included protective sleeving and push onto lines ②, ③ and ④. Push remaining end of protective sleeving onto line ①.



Preparing additional relay K3.1

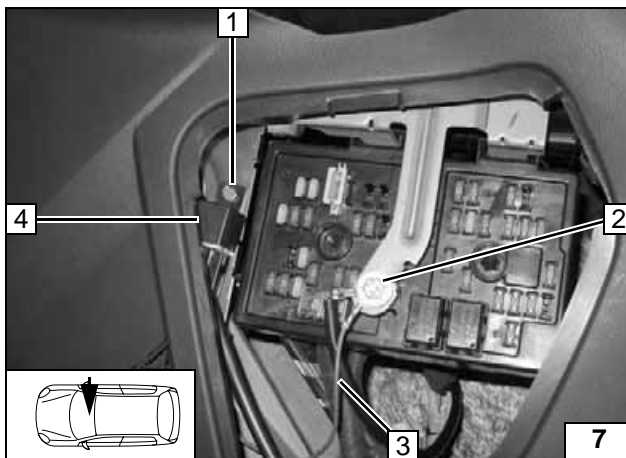

Fan controller

Produce connections as shown in wiring diagram.

- 1 Mount M5x16 bolt, flanged nut in existing hole
- 2 Original vehicle ground support point
- 3 Brown (br) wire ⑤ 0,75² from K3.1/85
- 4 Additional relay K3.1



Connecting additional relay

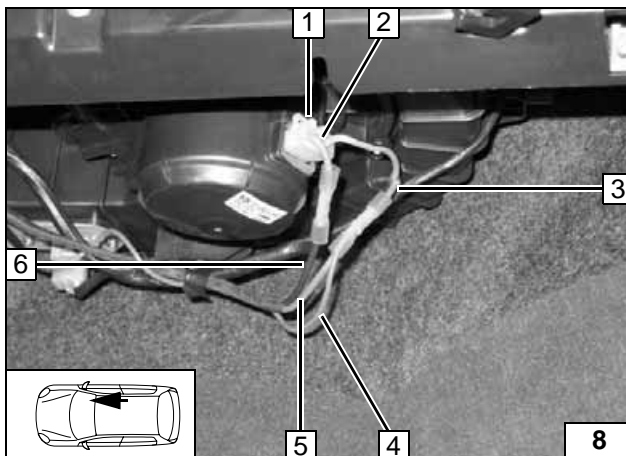

Connection to 2-pin connector 1 from fan motor.

Produce connections as shown in wiring diagram (crimp and shrink).

- 2 Brown (br) wire to connector
- 3 Brown (br) wire from fuse EF3
- 4 Red (rt) wire ① 2.5² from K3.1/86
- 5 Red (rt) wire to K3/87a
- 6 Black (sw) wire from K3/30



Connecting fan motor

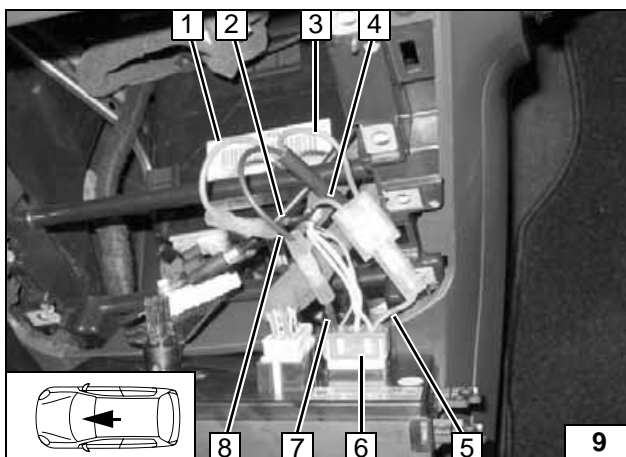

Connection to 6-pin connector 6 from fan switch.

Produce connections as shown in wiring diagram (crimp and shrink).

- 1 Brown (br) wire ④ 4² from K3.1/30
- 2 Black (sw) wire to original vehicle ground point
- 3 Red (rt) wire ③, 2.5² from K3.1/87a
- 4 Blue/green (bl/gn) wire to resistor group
- 5 Blue/green (bl/gn) wire from connector A1
- 7 Black (sw) wire from connector A6
- 8 Black (sw) wire ②, 4² from K3.1/87



Connection to fan switch



Automatic air-conditioning fan controller

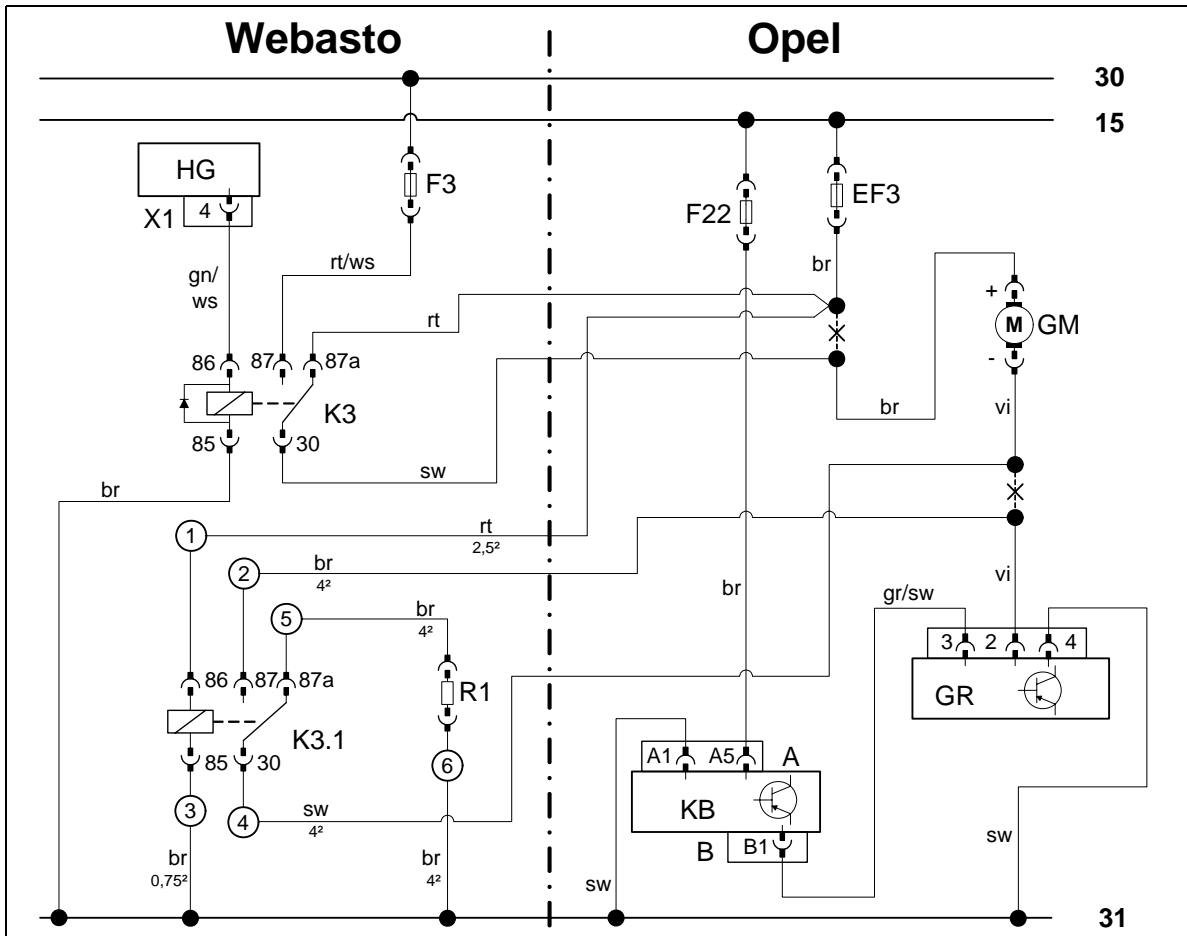

Automatic air-conditioning circuit diagram

Webasto components		Components of Opel Antara		Colors and symbols	
HG	Heater unit TT-C/E	GM	Fan motor	rt	red
X1	6-pin heater unit connector	GR	Fan controller	ws	white
F3	Fuse, 25 A	KB	Air-conditioning control element	sw	black
K3	Fan relay	F22	Fuse 10A	br	brown
K3.1	Additional relay	EF3	Fuse 40A	gn	green
R1	0.9 ohm resistor	A	Connector for A/C control panel	bl	blue
		B	Connector for A/C control panel	GR	gray
				vi	violet
				X	Cutting point
				Wiring colors may vary.	

Legend

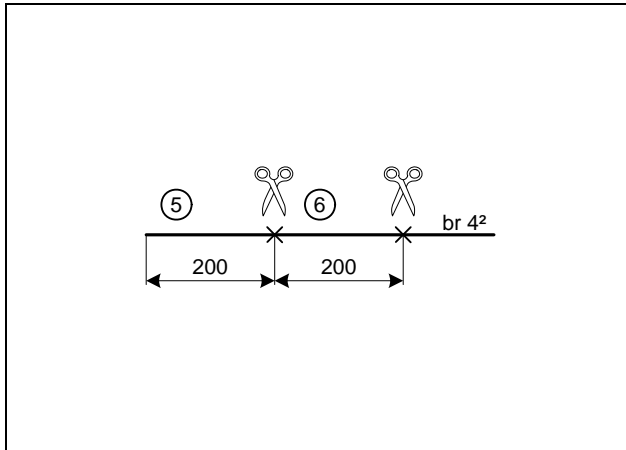

Preparing electrical system

Produce connections as shown in wiring diagram.
Crimp cable lug onto brown (br) wire ③ 0.75² provided and onto brown (br) wire section ⑥ 4²

Cutting brown (br) wire to length

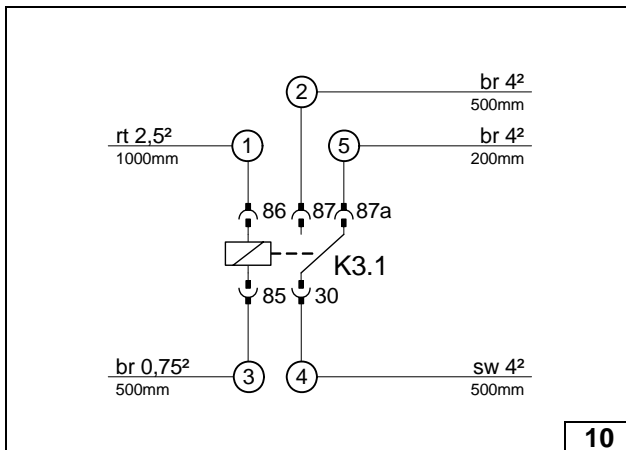

Produce connections as shown in wiring diagram.
Pull wires ①, ② and ④ in protective sleeving provided.

Preparing additional relay K3.1

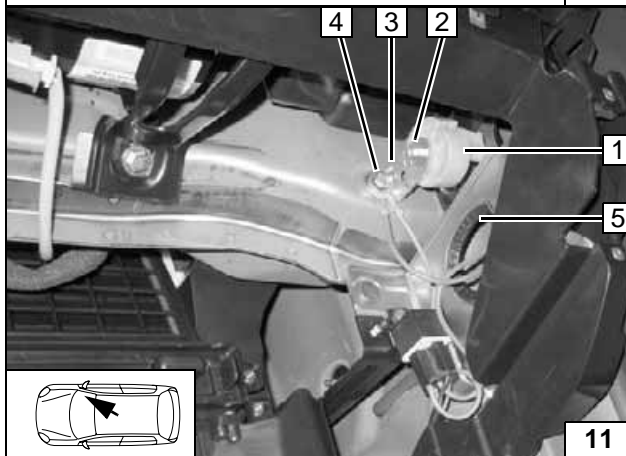

Fan controller

Resistor 1 becomes hot!
Ensure sufficient spacing (at least 20 mm) to neighboring components.



- 3 M5x30 cap screw, large diameter washer, nut [2x]
- 2 Angle bracket
- 1 M6x20 bolt, spring lockwasher, brown (br) ground wires ③ 0.75² and ⑥ br 4² on existing threaded hole
- 5 Mount edge protection

Installing resistor and additional relay

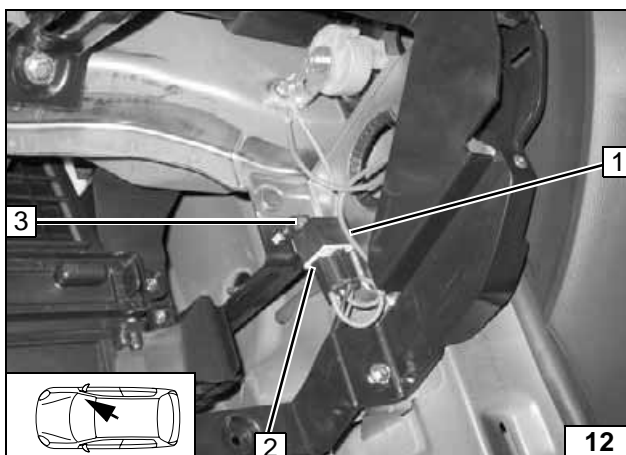

Produce connections as shown in wiring diagram.

- 1 Brown (br) wire ⑤ 4² from K3/87a to resistor
- 2 Additional relay K3.1
- 3 M5x16 bolt, flanged nut on existing hole

Connecting resistor and additional relay

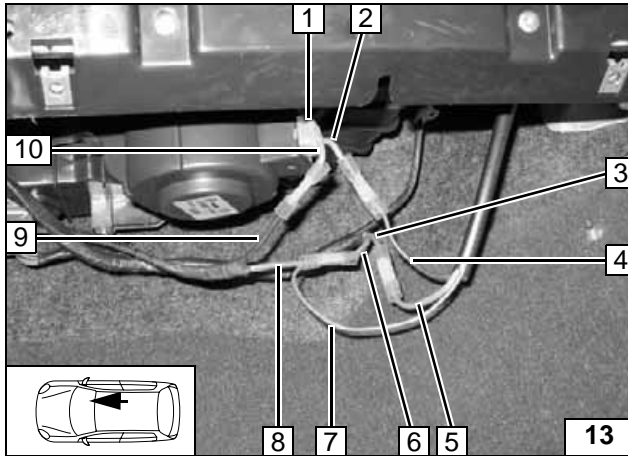

Connection to 2-pin connector 1 from fan motor.
Produce connections as shown in wiring diagram (crimp and shrink).

- 2 Violet (vi) wire from connector
- 3 Violet (vi) wire to fan controller
- 4 Black (sw) wire ④, 4² from K3.1/30
- 5 Brown (br) wire ② 4² from K3.1/87
- 6 Brown (br) wire from fuse EF3
- 7 Red (rt) wire ① 2.5² from K3.1/86
- 8 Red (rt) wire to K3/87a
- 9 Black (sw) wire from K3/30
- 10 Brown (br) wire to connector



Con-necting fan motor

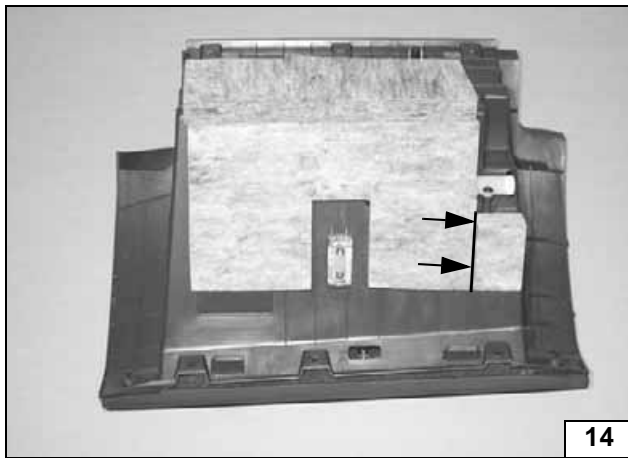

Cut away **insulation** of glove compartment at marking.



Cutting away insulation

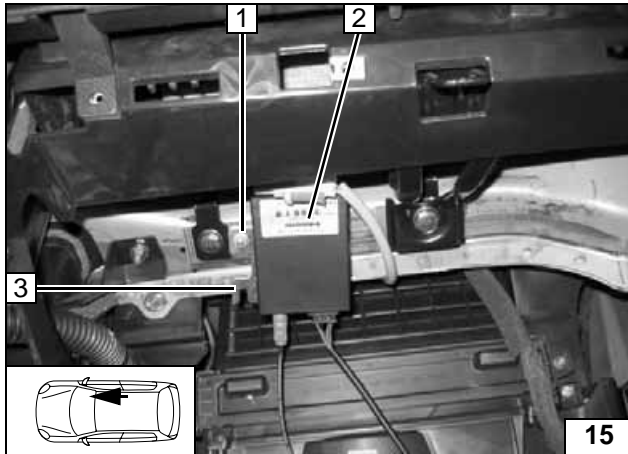

Remote option (Telestart)

- 1 Existing hole, M5x16 bolt, washer, flanged nut
- 2 Receiver
- 3 Telestart bracket



Installing receiver

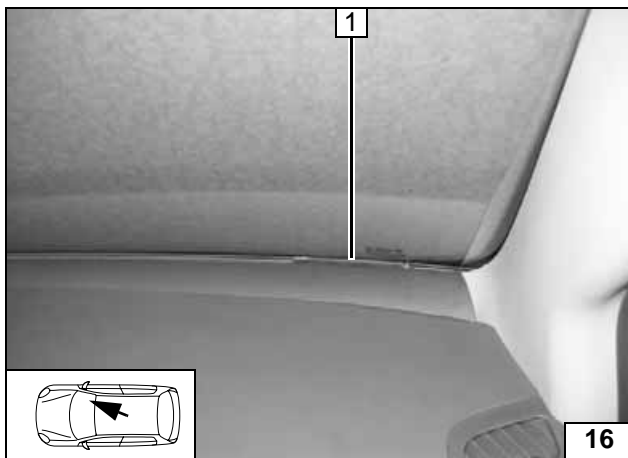

- 1 Antenna

Installing antenna

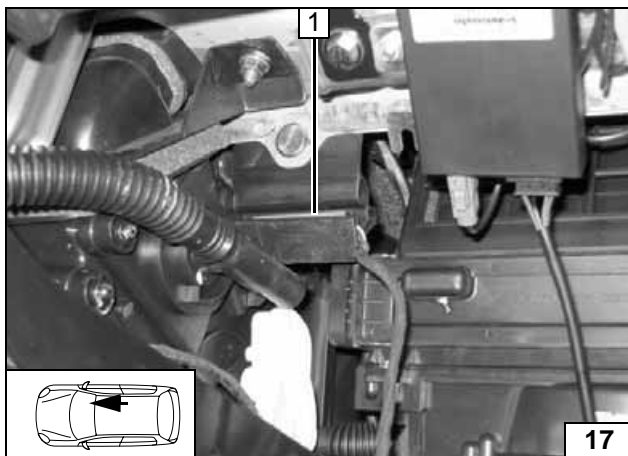

Temperature sensor for HTM100 only

- 1 Fasten temperature sensor with suitable means (here double-sided adhesive tape)

Installing temperature sensor

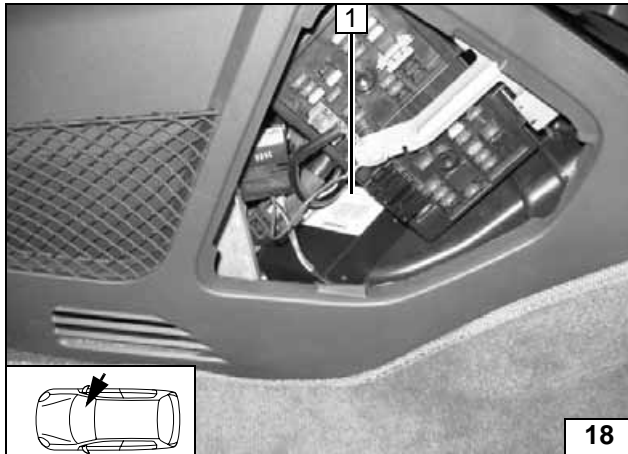

Remote option (Thermo Call)

1 Fasten receiver with suitable means (here double-sided adhesive tape)



Installing receiver

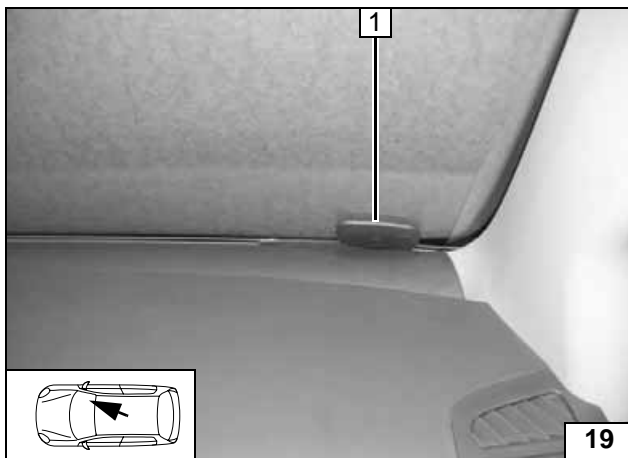

1 Antenna

Installing antenna

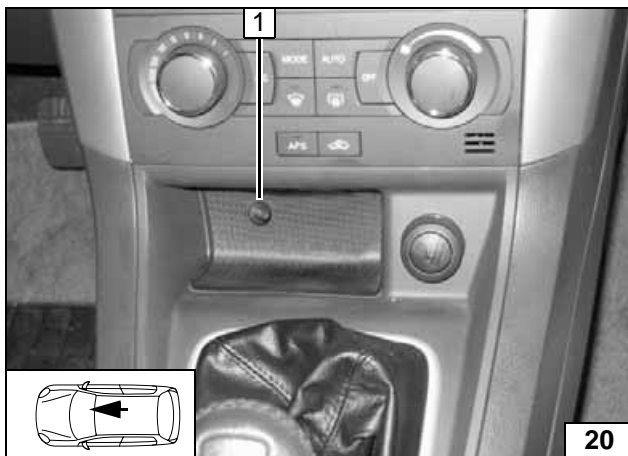

1 Pushbutton

Installing push button

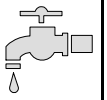

Coolant connection diagram

WARNING!

Tighten all hose clamps to 2.0 + 0.5 Nm.

Any coolant running off should be collected using an appropriate container.



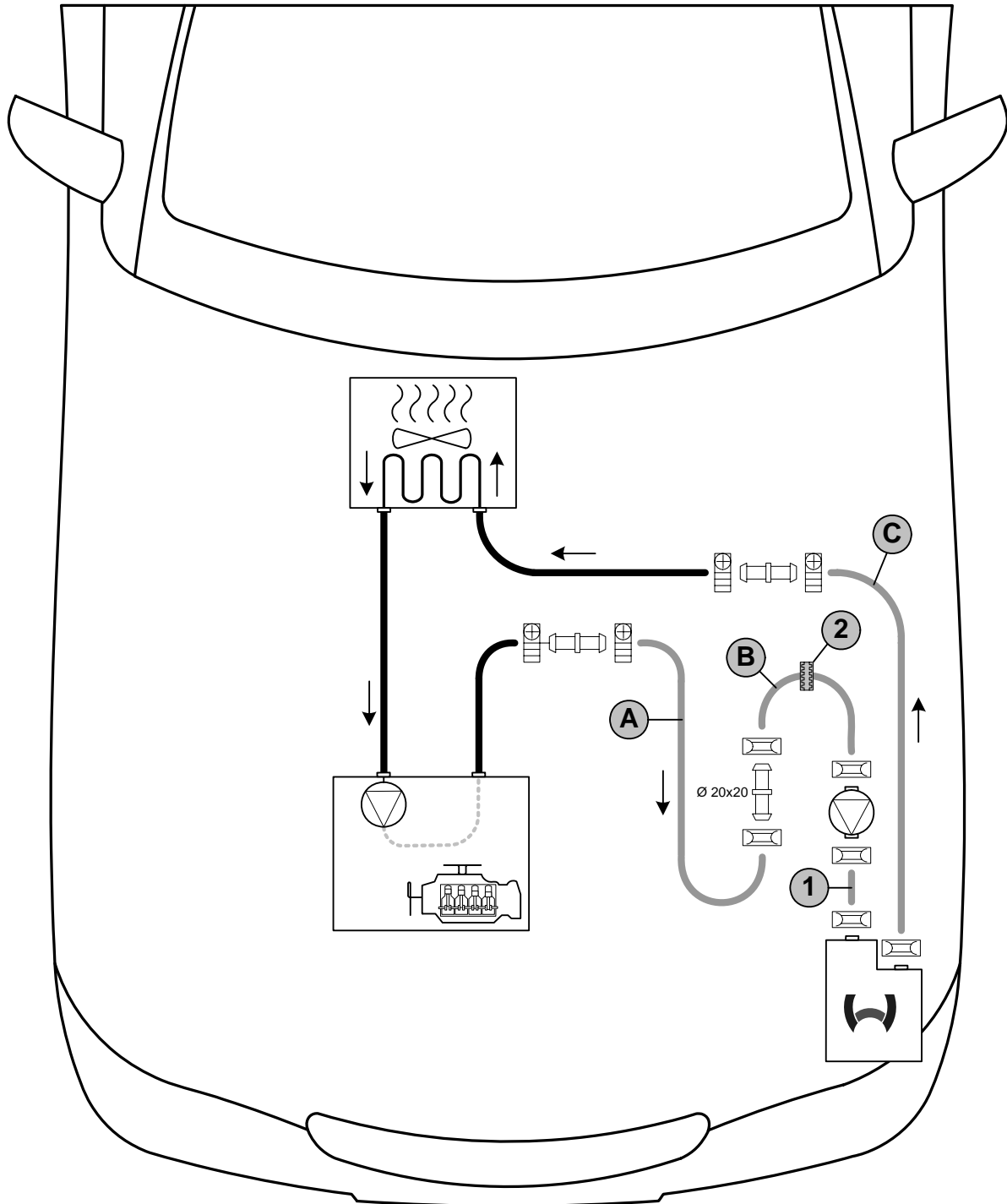

Install hoses so that they are kink-free. Unless specified otherwise, always fasten using cable ties.

Position hose clamps and spring band clamps so that no other hose can be damaged.

The connection should be "inline" based on the following diagram:



Coolant routing diagram

All spring clips without a specific designation  = 27 mm dia. **2** = Black (sw) rubber isolator  . All hose clamps without a specific designation  = 20-27 mm dia All connecting pipes without a specific designation  = dia. 18x20. **1** = hose section between circulating pump and heater unit inlet.



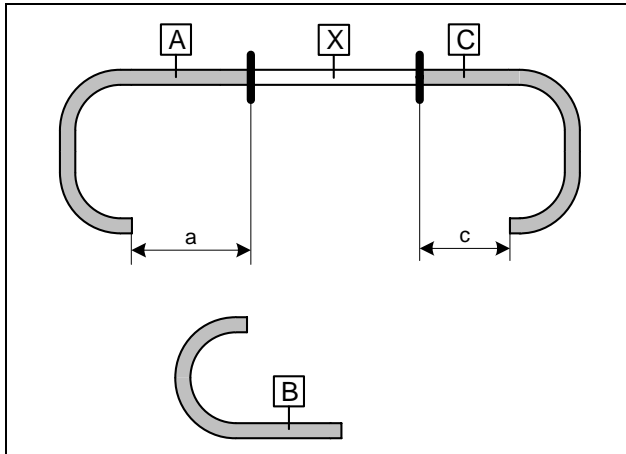
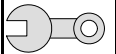

Preparing heater unit

a = 620 mm
c = 540 mm

Discard section X



Cutting coolant hoses to length

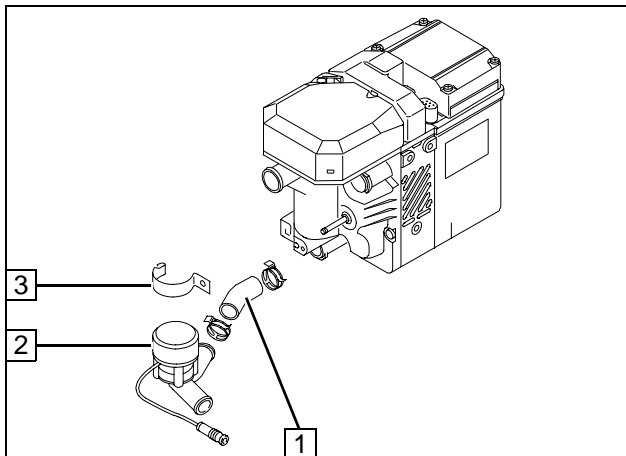

Remove water pump **2** from heater unit. Hose section **1** and spring clip will be reused. Discard retaining clip **3** and bolt.



Removing water pump

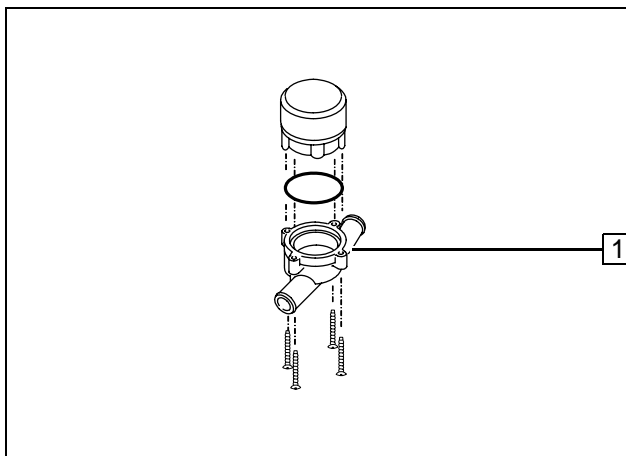

Replace 193° lid **1**.



Replacing pump lid

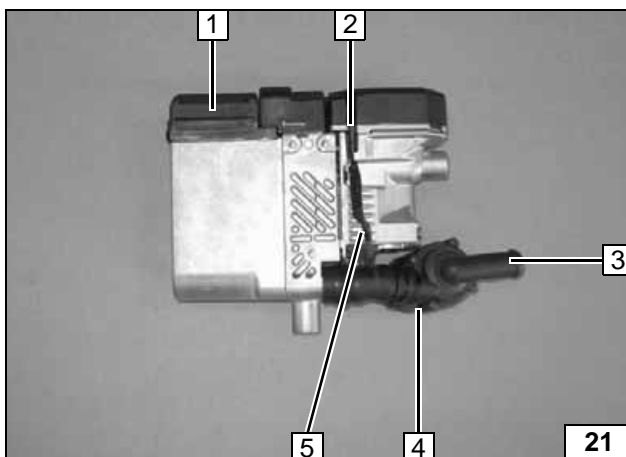

Connect adapter line of water pump **2**, cut to length and connect identical colors to wiring harness of water pump **5** using connectors (crimp and shrink).

- 1** Heater unit
- 3** 193° water pump
- 4** Water pump



Preassembling water pump

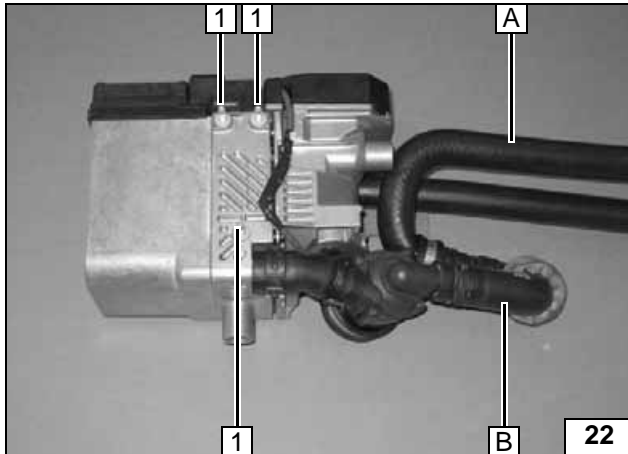
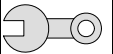

Tighten EJOT screws to 10 Nm!

1 Ejot stud [3x]



Preassembling
heater unit

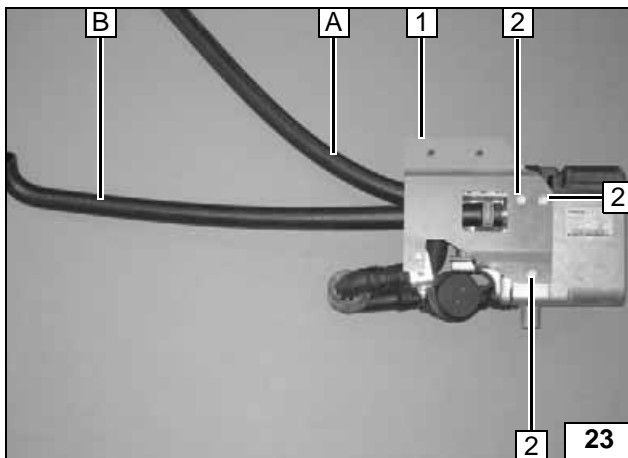

1 Bracket part 1
2 Ejot screw [3x]

Preassembling
heater unit

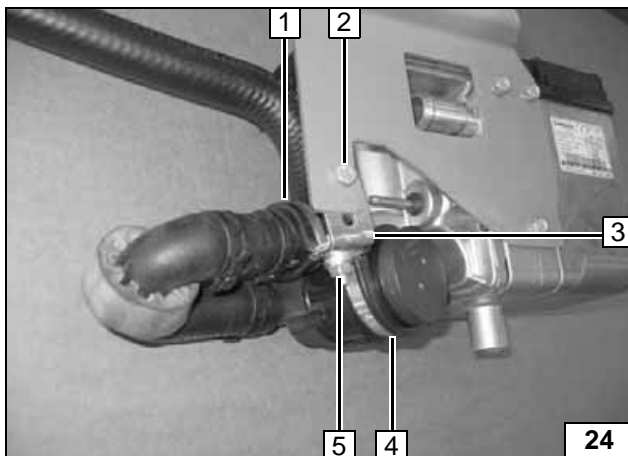

1 Rubber-coated pipe clamp, 29 mm dia.
2 M6x20 bolt, flanged nut M6
3 Angle bracket
4 Rubber-coated pipe clamp, 48 mm dia.
5 M6x12 bolt, flanged nut M6

Preassembling
heater unit

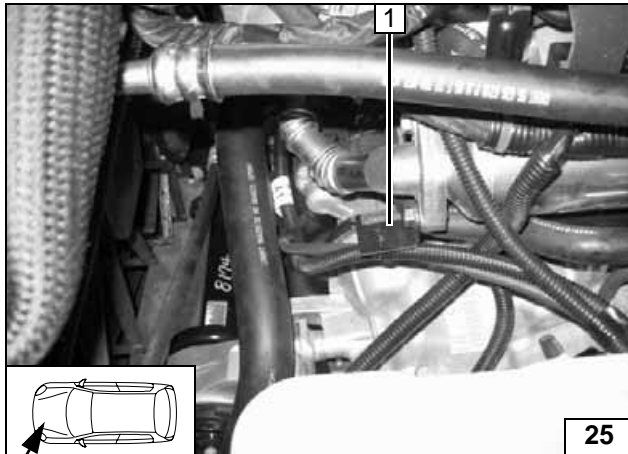
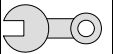

Preparing installation location

- 1 Remove bracket for wiring harness

Removing bracket for wiring harness

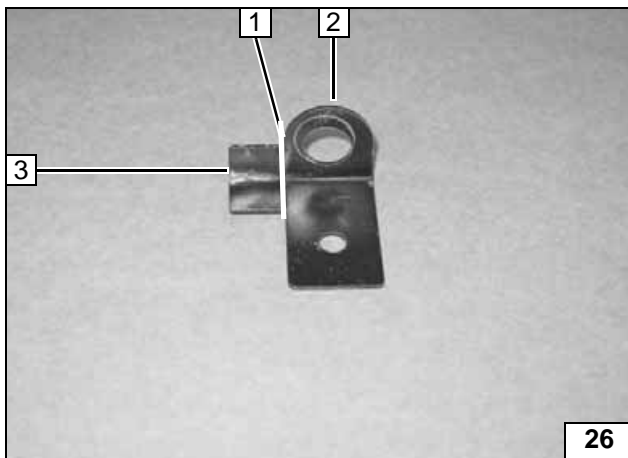

- 1 Cutting point
- 2 Bracket for wiring harness
- 3 Discard section

Machining bracket for wiring harness

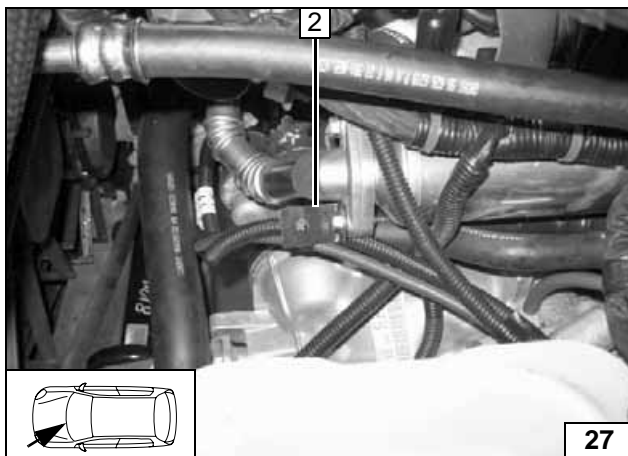

- 1 Mount bracket for wiring harness as shown

Installing bracket for wiring harness

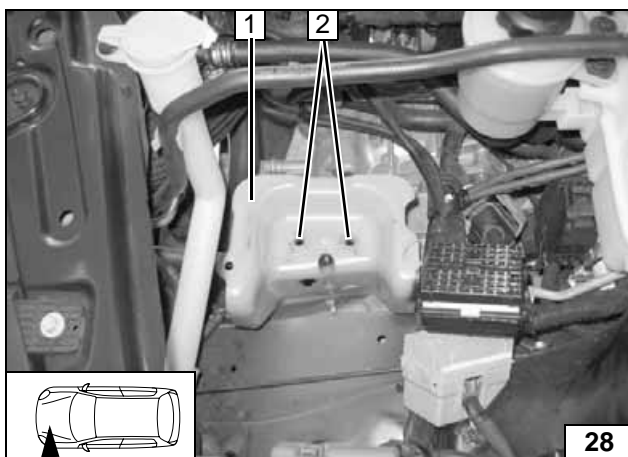

- 1 Cross member for battery carrier
- 2 Drill out thread to 10 mm dia. [2x]

Drilling out holes

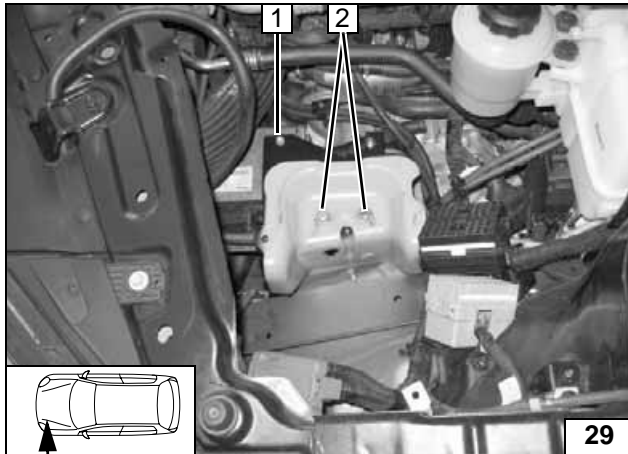
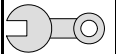

Installing heater unit

- 1 Preassembled heater unit
- 2 Loosely mount M8x30 bolt

Installing heater unit

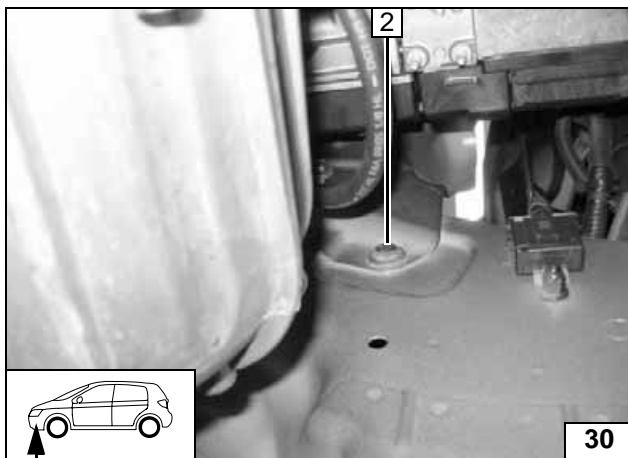

Remove original vehicle screw 1 and discard.



Removing original vehicle screw

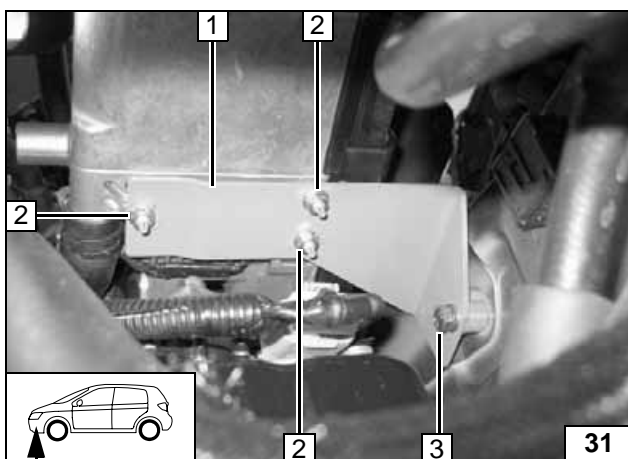

- 1 Bracket part 2
- 2 M6 flanged nut [3x]
- 3 M8x40 bolt, spring lockwasher, large diameter washer

Installing bracket part 2

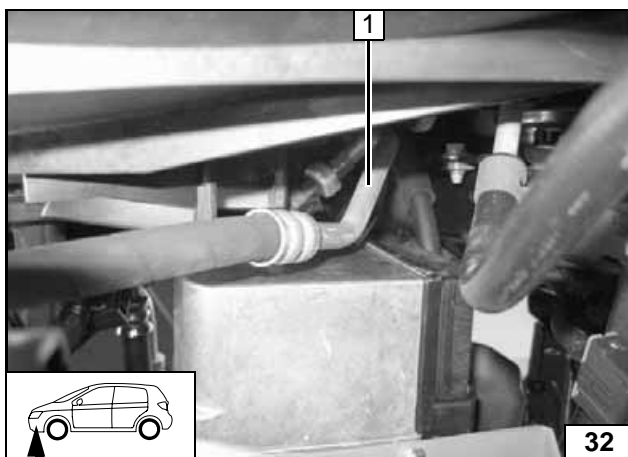

Ensure sufficient spacing to neighboring components, especially to A/C line 1; correct if necessary.



Aligning heater unit

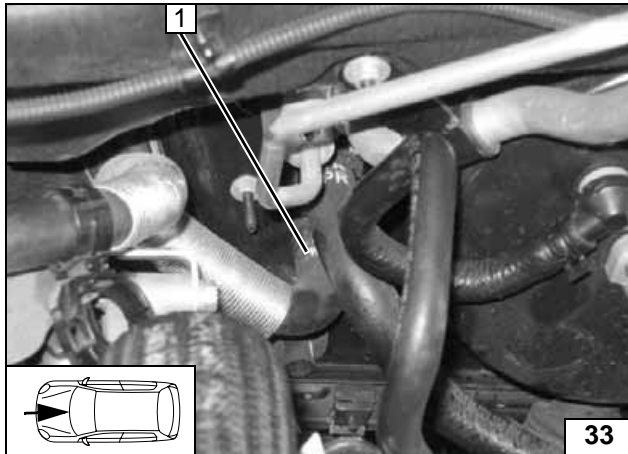

Coolant connection

Pull off hose between engine outlet and heat exchanger inlet 1 on heat exchanger.



Cutting point

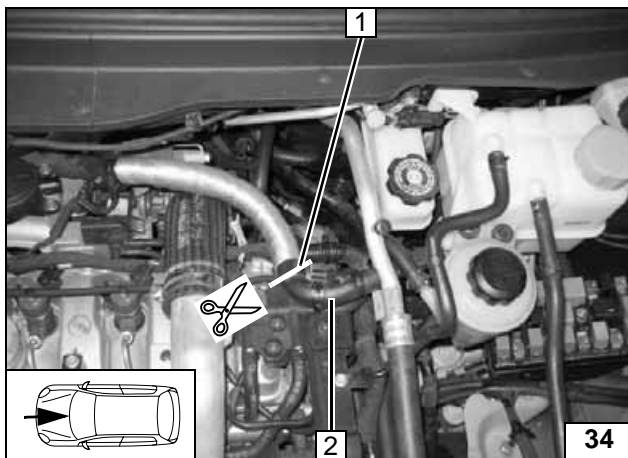

Push back heat guard.

- 1 Cutting point
- 2 Hose section of heat exchanger inlet



Cutting point

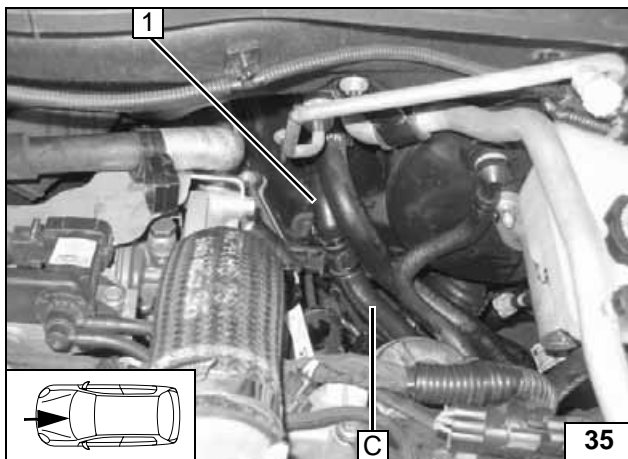

- 1 Hose on heat exchanger inlet

**Con-
nection on
heat
exchanger
inlet**

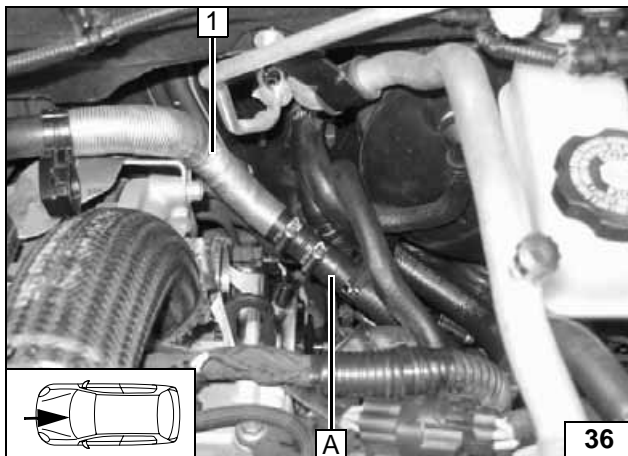

Before connecting, fill the coolant hoses with coolant.

- 1 Hose of engine outlet



**Con-
nection to
engine
outlet**

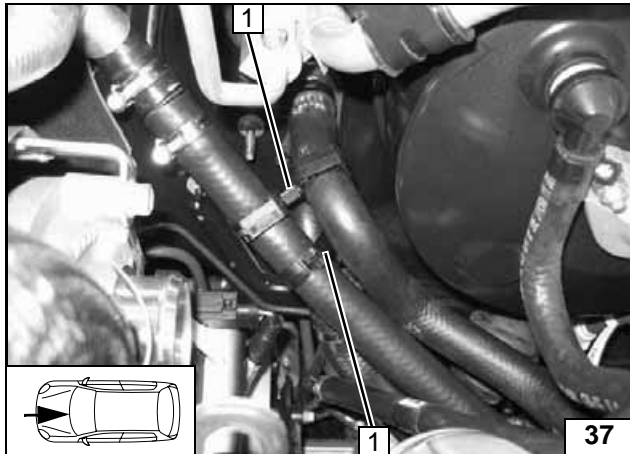

1 Spacer bracket [2x]

Installing
spacer
bracket

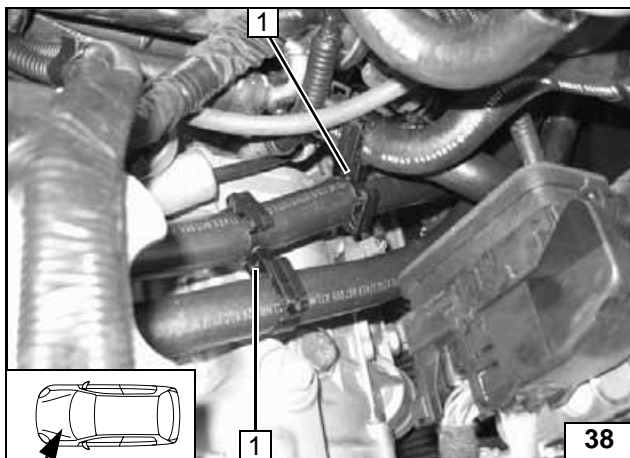

1 Spacer bracket [2x]

Installing
spacer
bracket



Fuel Connection

CAUTION!

Open the vehicle's fuel tank cap, ventilate the tank and then re-close the tank lock.

Catch any fuel running off with an appropriate container.

Install fuel line and metering-pump wiring harness so that they are protected against stone impact. Unless specified otherwise, always fasten using cable ties. Mount the fuel line and wiring harness with rub protection on sharp edges.

WARNING!

The fuel line and wiring harness are routed to the metering pump in as shown in the wiring harness routing diagram.

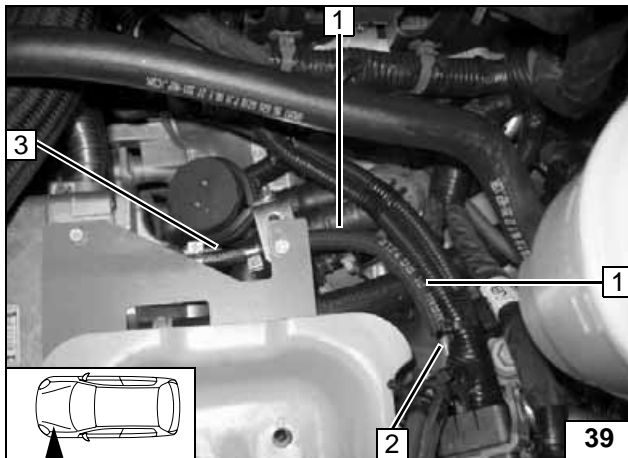

- 1 Included hose section as scuff guard [2x]
- 2 Fuel line
- 3 Hose section, 10 mm dia. hose clamp [2x]

Con-
nection on
heater unit

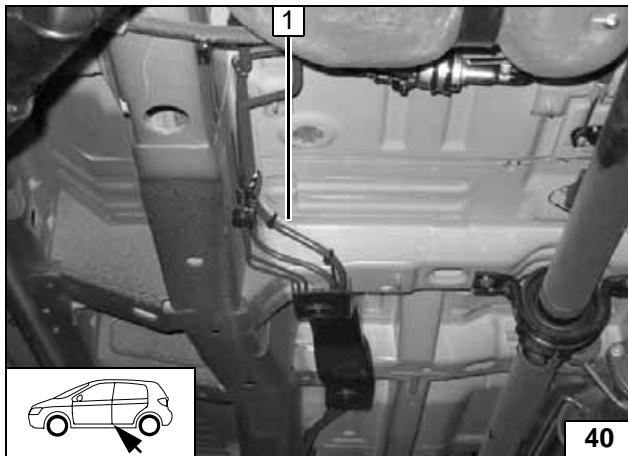

- 1 Mecanyl fuel pipe and metering pump cable harness

Installing
lines

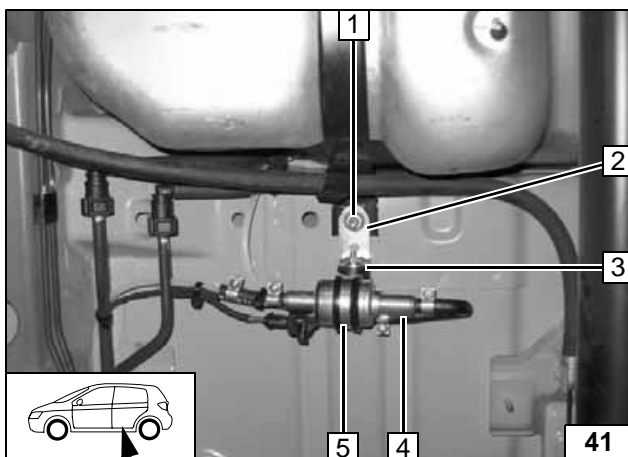

Ensure proper installation position of metering pump, see "Installation Instructions".
Installation location in front of vehicle fuel tank!

- 1 Original vehicle nut
- 2 Angle bracket
- 3 Silent block, flanged nut [2x]
- 4 Metering pump
- 5 Rubber-coated pipe clamp



Installation
location of
metering
pump

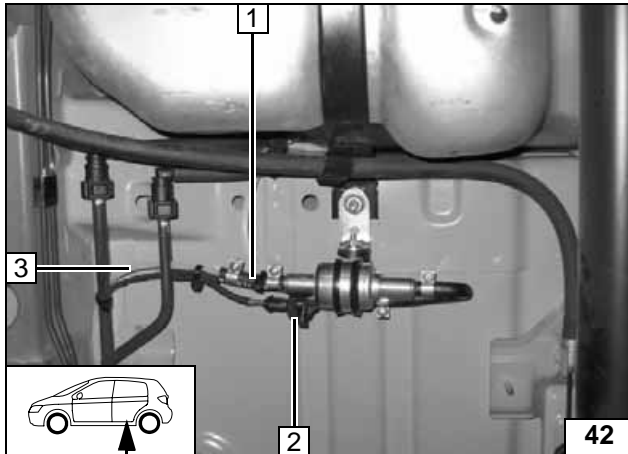

Fuel line from heater unit on pressure side of metering pump [side with connector].

- 1 Hose section, 10 mm dia. hose clamps [2x]
- 2 Wiring harness of metering pump, connector mounted
- 3 Fuel line



Installing metering pump

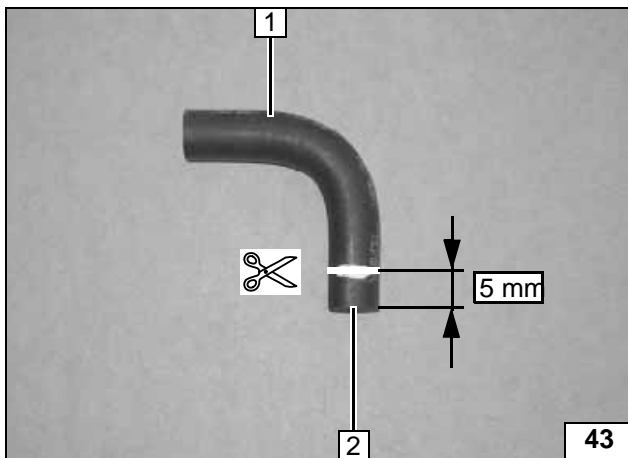

- 1 Separate 90° molded hose at marking
- 2 Discard section

Preparing fuel standpipe

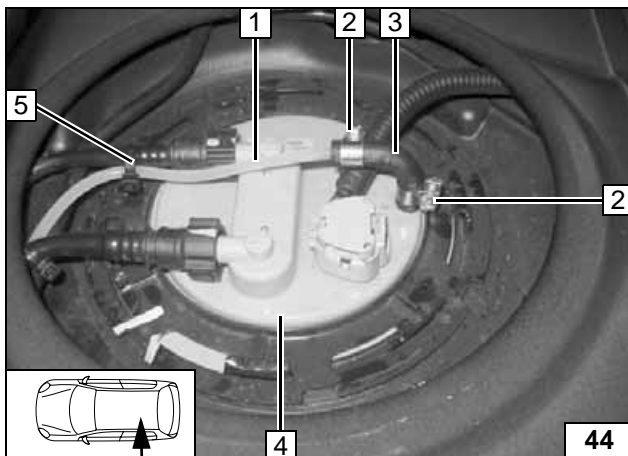

Cut closure off existing removal connection piece and push on short end of 90° molded hose 3.

- 1 Fuel line
- 2 10 mm dia. hose clamp [2x]
- 4 Fuel sender
- 5 Cable tie



Removing fuel

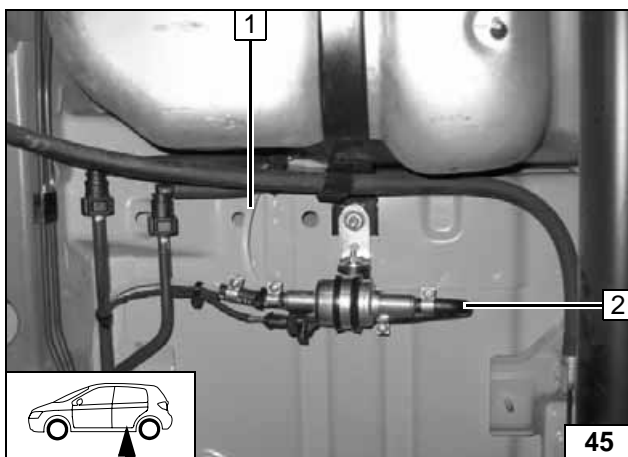

Fuel line 1 from fuel standpipe on intake side of metering pump [side without connector]. Check the position of the components; adjust if necessary. Check that they have free clearance.

- 2 180° molded hose, 10 mm dia. hose clamp [2x]



Connecting to metering pump

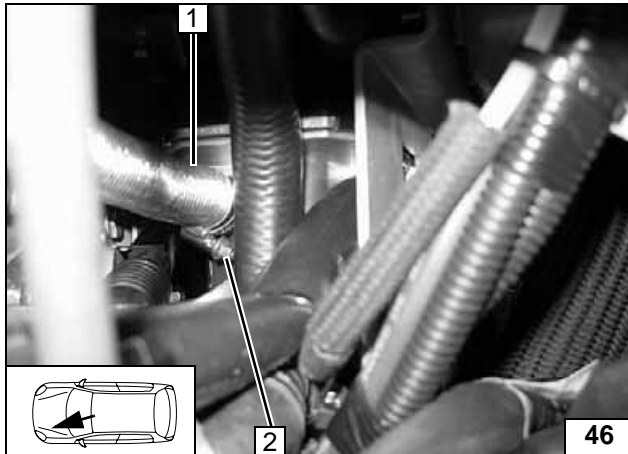

Combustion air

- 1 Combustion air pipe
- 2 Hose clamp

Installing combustion air pipe

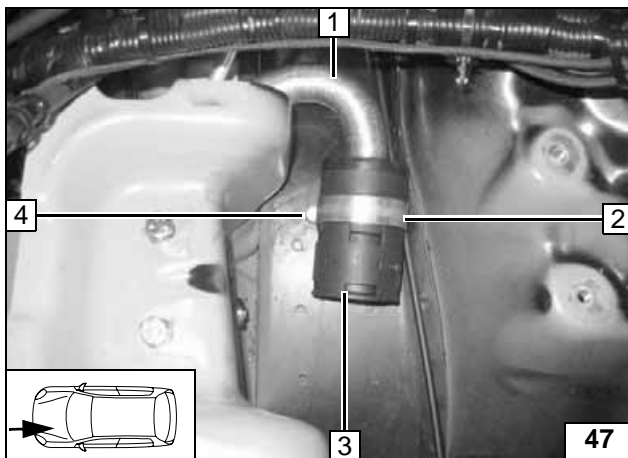

- 1 Combustion air pipe
- 2 48 mm dia. p-clamp; rubber coating removed
- 3 Combustion-air intake muffler
- 4 Existing hole, M6 rivet nut, M6x20 bolt, spring lock washer



Installing muffler

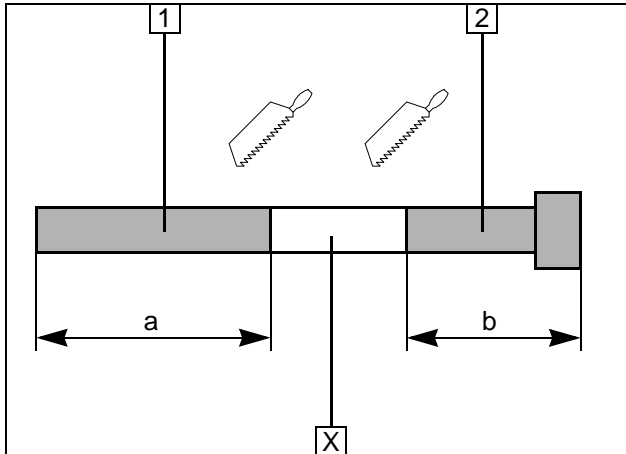
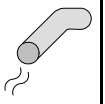

Exhaust system

- 1 Exhaust pipe
a = 420 mm
- 2 Exhaust end section
b = 120 mm

Discard section X

Preparing exhaust pipe

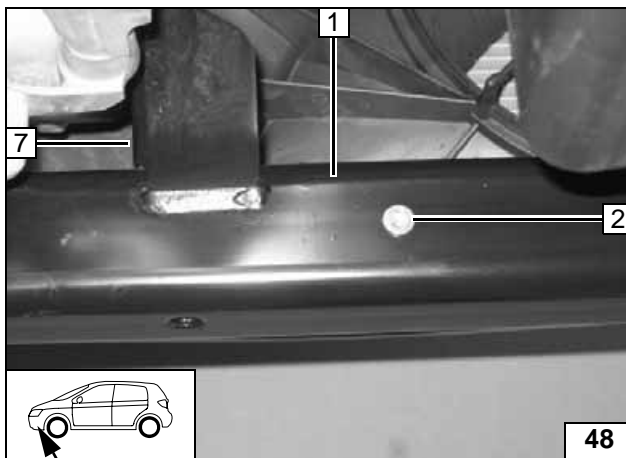

- 1 Radiator cross member
- 2 Drill out existing hole to 9.1 mm dia., mount M6 rivet nut

Installing muffler

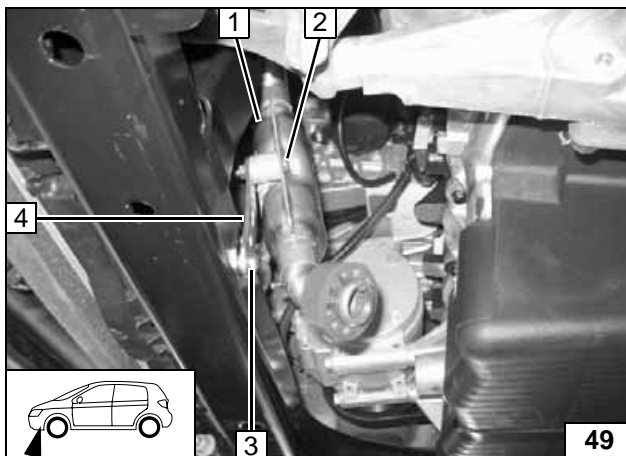

- 1 Exhaust muffler
- 2 M6x35 bolt, 20 mm spacer, M6 flanged nut
- 3 M6x20 bolt, spring lockwasher
- 4 Perforated bracket

Installing muffler

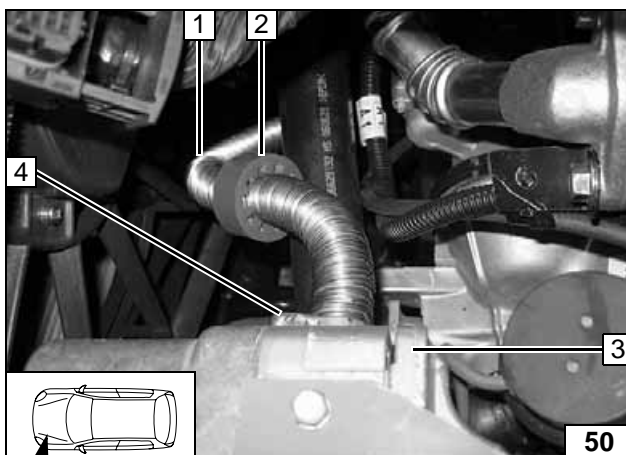

- 1 Exhaust pipe
- 2 Position red (rt) rubber isolator
- 3 Heater unit
- 4 Hose clamp

Installing exhaust pipe

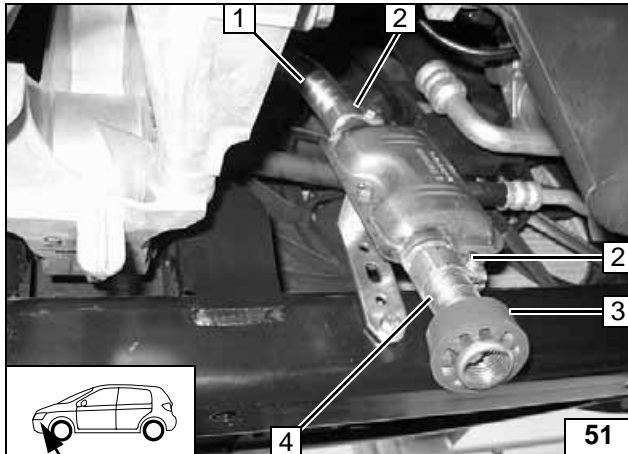
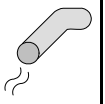

Ensure sufficient distance to neighboring components.

- 1 Exhaust pipe
- 2 Hose clamp [2x]
- 3 Red (rt) rubber isolator
- 4 Exhaust end section



Installing exhaust pipe and end section

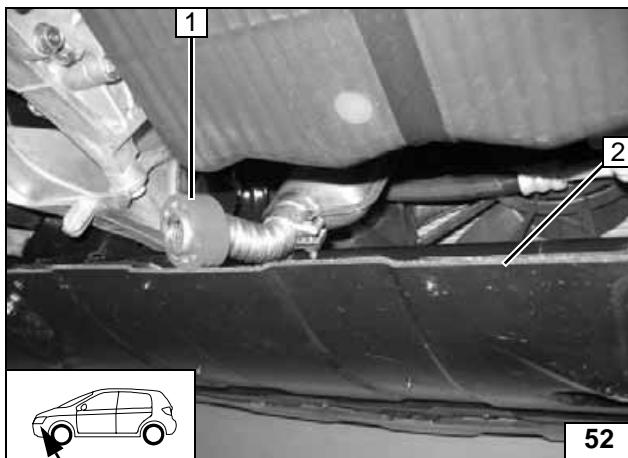

- 1 Red (rt) rubber isolator
- 2 Bumper cover

Positioning rubber isolator

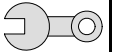

Final Work

WARNING!

Reassemble the disassembled components in reverse order.

Check all hoses, hose, spring and Caillau clamps, as well as all electrical connections for firm seating.

Secure all loose cables using cable ties.

Only use manufacturer-approved coolant.

Spray the heater unit components with anti-corrosion wax (Tectyl 100K, Order No. 111329).

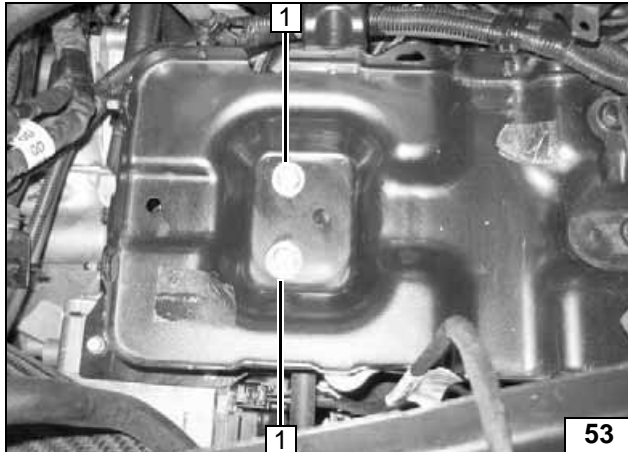

1 M8x30 bolt, spring lockwasher, flanged nut
[2x each]

Installing
battery
carrier

- Connect the battery
- Bleed and fill the coolant circuit according to the vehicle manufacturer's specifications.
- Set the digital timer.
- Set the manual air conditioning or automatic air conditioning according to the "operating instructions for the end customer".
- Check the proper operation of the additional heater, see the operating instructions/installation instructions.
- Attach the "Switch off additional heater before refueling" sticker to the left-hand B-pillar.



Webasto
Feel the drive

Webasto AG
Postfach 80 - 82132 Stockdorf
Hotline 01805 / 932278 - Hotfax 0395 / 5592-353
<http://www.webasto.de>

Operating Instructions for End Customer



Please remove page and add to the vehicle operating instructions.

Note:

We recommend matching the heating time to the driving time.

Heating time = driving time

Example:

For a driving time of approx. 20 min. (in one direction), we recommend not exceeding a switch-on time of 20 min.

If the summer/winter switch option has been installed, this must be switched in accordance with the time of year. The heater unit will then only switch on the vehicle fan to ventilate the vehicle interior in the position Winter heat or in the position Summer .

Before parking the vehicle, make the following settings:

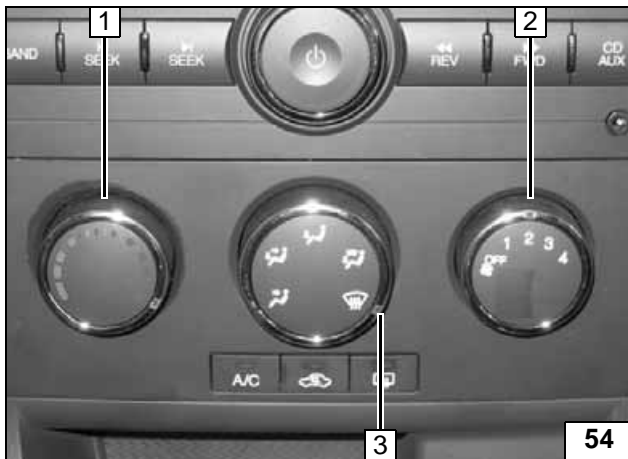

- 1 Set temperature to "max."
- 2 Set fan to level "1", or possibly "2"
- 3 Direct air outlet toward windshield

Manual air conditioning

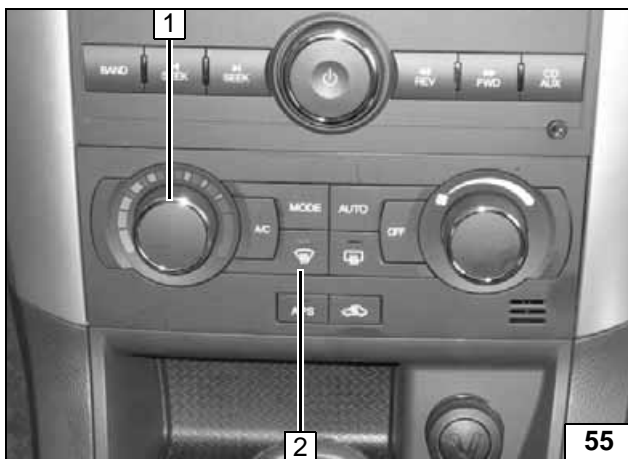

- 1 Set temperature to "max."
- 2 Air outlet to windshield

Automatic air-conditioning