

Water Heater Unit



Feel the drive

Thermo Top E Additional Heater



00 0003

Installation Instructions

Ford Focus / Focus C-MAX / Focus CC

Gasoline

from Model Year 2004

For left-hand drive vehicles only



WARNING!

Hazard warning:

Incorrect installation or repair of Webasto heating systems may cause a fire or result in the emission of carbon monoxide, which can be fatal. Serious or fatal injuries can be caused as a result.

Specialist company training, technical documentation, specialized tools and equipment are required to install and repair Webasto heating and cooling systems.

NEVER attempt to install or repair Webasto heating or cooling systems if you have not successfully completed the company training and thereby acquired the required technical skills, or if you do not have access to the required technical documentation, tools and equipment needed to carry out correct installation and repairs.

ALWAYS follow all Webasto installation and repair instructions and observe all warnings.

Webasto does not accept any liability for defects and damage that are attributable to installation by untrained staff.

Ford Focus / Focus C-MAX / Focus CC

Table of Contents

Validity	2	Remote Option (Telestart)	15
Heater Unit/Installation Kit	3	Thermo Call Option on Focus	16
Foreword	3	Thermo Call Option on C-MAX	17
Special Tools	3	Preparing Installation Location	18
Explanatory Notes on the Document	3	Premounting Coolant Connection	20
Preliminary Work	5	Preassembling Heater Unit	21
Heater Unit Installation Location	5	Fastening for Underride Protection	22
Preparing Electrical System	6	Installing Heater Unit	23
Electrical Connection on Focus	7	Coolant Connection	25
Electrical Connection on Focus/Focus CC from 2008	8	Fuel Connection	26
Electrical Connection on C-MAX	9	Installing Underride Protection	29
Fan Controller without Automatic Air-Conditioning	10	Final Work	30
Automatic Air-Conditioning Fan Controller In Addition with Automatic Air-Conditioning from 12/05	11 12	Operating Instructions for End Customer	31

Validity

Manufacturer	Model	Type	EG-BE No./ABE
Ford	Focus	DA3	e13*2001/116*0144
Ford	Focus	DB3	e13*2001/116*0144
Ford	Focus C-MAX	DM2	e13*2001/116*0109
Ford	Focus CC	DB3	e13*2001/116*0157

Engine type	Engine model	Output in kW	Displacement in cm ³
ASDA	Gasoline	59	1388
ASDB	Gasoline	59	1388
HWDB	Gasoline	74	1596
HXDA	Gasoline	85	1596
Q7DA	Gasoline/Flexifuel	92	1798
QQDB	Gasoline	92	1798
AODA	Gasoline	107	1999
AODB	Gasoline	107	1999

Vehicle and engine types, equipment variants and national specifications not listed in these installation instructions have not been tested. However, installation according to these installation instructions may be possible.

The installation location of a digital timer and summer/winter switch should be confirmed with the end customer before installation.

Ford Focus / Focus C-MAX / Focus CC

Heater Unit/Installation Kit

Quantity	Description	Order No.:
1	Ford Delivery Scope for Focus/ Focus C-MAX Gasoline without Heater Control	1303858C
1	Original Fuel Standpipe with Ford Finis Code	1233999

Additionally required optional heater control:

Quantity	Description	Order No.:
1	Digital Timer	9010869A
1	Telestart T80	9010870A
1	Telestart T100 HTM	9010148C
1	Thermo-Call Connect, Comfort, Locate	See price list

Additionally required with automatic air-conditioning up to 2005 Model Year:

Quantity	Description	Order No.:
1	Kit for Automatic Air-Conditioning on Ford Focus/Focus C-MAX	9012822A

Additionally required with automatic air-conditioning from 2006 Model Year:

Quantity	Description	Order No.:
1	Kit for Automatic Air-Conditioning on Ford Focus/Focus C-MAX	9015495A

Foreword

The installation instructions apply to the Ford Focus / Focus C-MAX / Focus CC vehicles with a Gasoline engine

- For the validity, see page 2 - from model year 2004 and later, assuming technical modifications to the vehicle do not affect installation, any liability claims excluded. Depending on the vehicle version and equipment, modifications may be necessary during installation with respect to these installation instructions.

However, the stipulations in the "installation instructions" and "operating and maintenance instructions" for the *Thermo Top C/P/E* must always be observed.

The corresponding rules of technology and any information from the vehicle manufacturer should be observed during the installation work.

General Instructions

Installation should be carried out according to the general, standard rules of technology. Unless specified otherwise, fasten hoses, lines and wiring harnesses to original vehicle lines and wiring harnesses using cable ties.

Sharp edges should be fitted with edge protectors (split-open plastic hose).

Spray unfinished body areas, e.g. drilled holes, with anti-corrosion wax (Tectyl 100K, Order No. 111329).

Special Tools

- Torque wrench for 2.0 - 10 Nm
- Hose clamping pliers
- Metric thread-setter kit for M6 aluminum rivet nut
- Metric thread-setter kit for M10 steel rivet nut (e.g. Würth Order No. 0964948900)

Explanatory Notes on Document

To provide you with a quick overview of the individual working steps, you will find an identification mark on the outside top right corner of the page in question.

Mechanical work

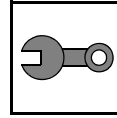

Electrical connection

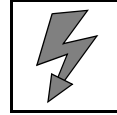

Coolant connection

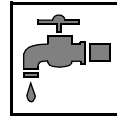

Fuel connection

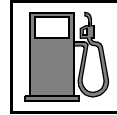

Exhaust system

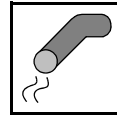

Combustion air

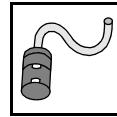

Special features are highlighted using the following symbols:



Specific risk of injury or fatal accidents.



Specific risk of damage to components.



Specific risk of fire or explosion.



Reference to general installation instructions of Webasto components or to the manufacturer's vehicle-specific documents.



Reference to a special technical feature.

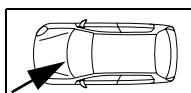
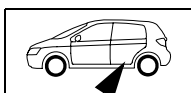

The arrow in the vehicle icon indicates the position on the vehicle and the viewing angle.

WARNING!

- Open fuel tank cap, ventilate tank.
- Close the tank cap again.
- Disconnect the battery "earth" or "ground" connection.
- Depressurize the cooling system.
- Copy the factory number from the original type label to the duplicate type label.
- Remove years that do not apply from the duplicate label.
- Attach the duplicate label (type label) in the appropriate place.
- Remove the engine cover (if present).
- C-MAX only: Remove the coolant reservoir trim completely at the top and bottom.
- Remove the underride protection (if present).
- Remove the underbody trim in front of the right rear wheel (no further use).
- Remove the fuel tank according to the manufacturer's instructions.
- Remove the glove compartment.
- Remove the A-pillar trim in the footwell on the front passenger side.
- Only with automatic air-conditioning: Remove the A/C control panel according to the manufacturer's specifications.



Preliminary Work

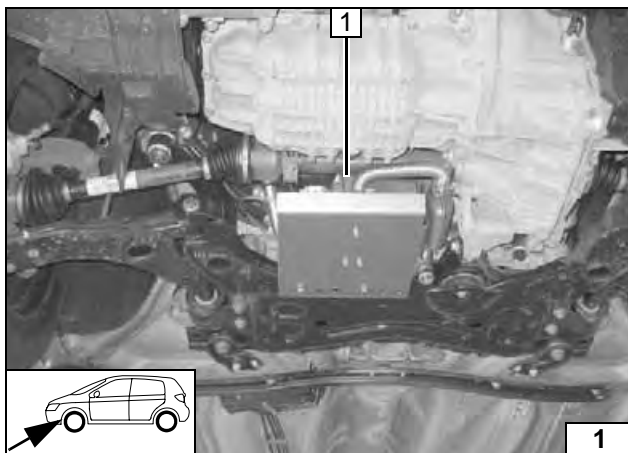

Heater unit installation location

Photo shows 1.8 liter

1 Heater unit



Installation location

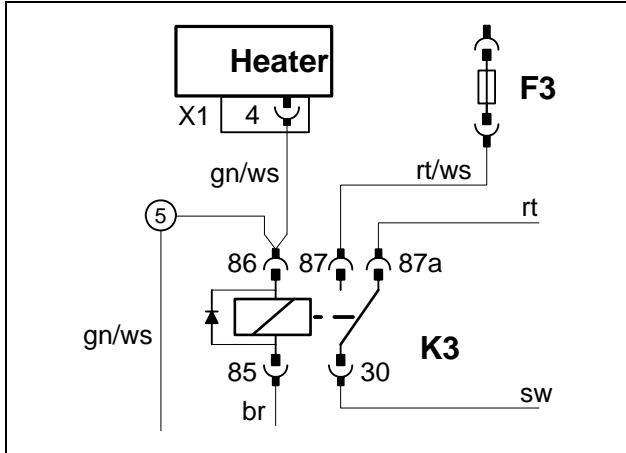

Preparing electrical system

Only with automatic air-conditioning
Connect additional green/white (gn/ws) wire 5 to K3/86 and pull into protective sleeving.



Wiring diagram for additional wire

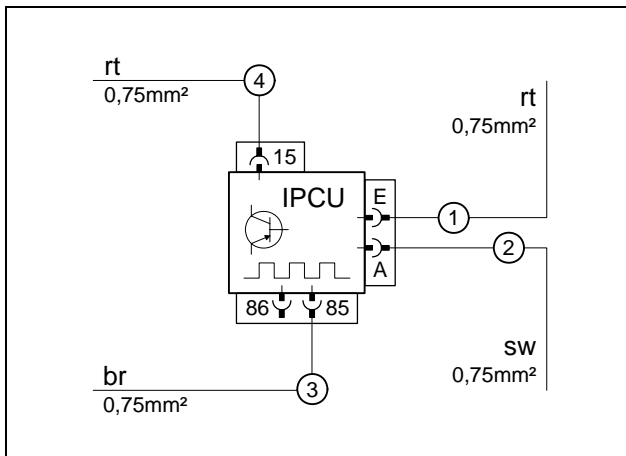

Connect lines provided to IPCU as shown in wiring diagram.
Connect 6 mm dia. cable lug to end of brown (br) wire from IPCU/85 3.



Premounting IPCU connection



Electrical Connection on Focus

Wiring harness pass through

- 1 Protective rubber plug detached

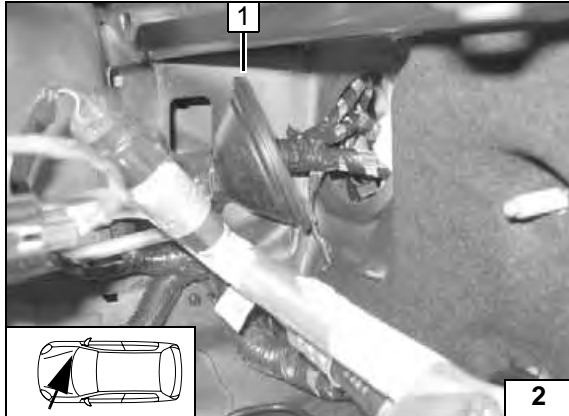

Digital timer

- 1 Digital timer
- 2 Summer/winter switch, drilled hole 12 mm dia.

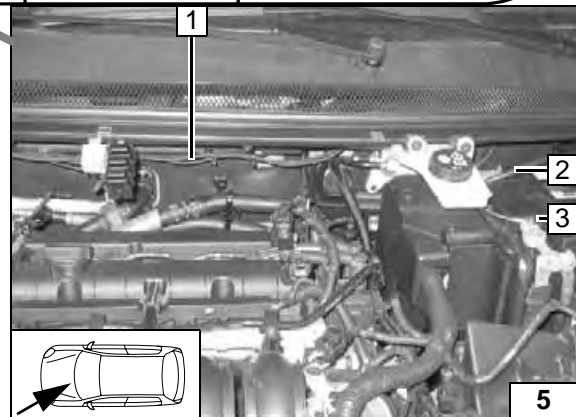
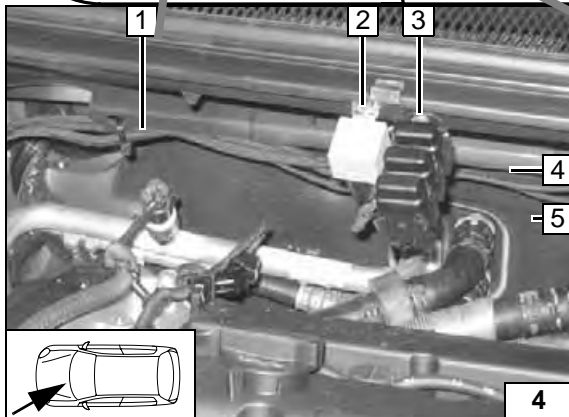
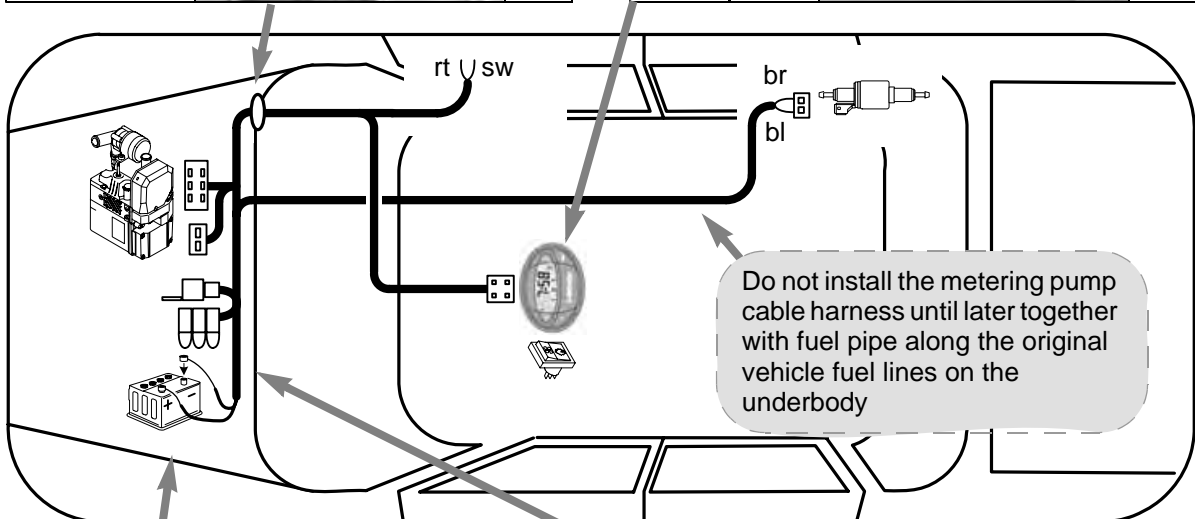
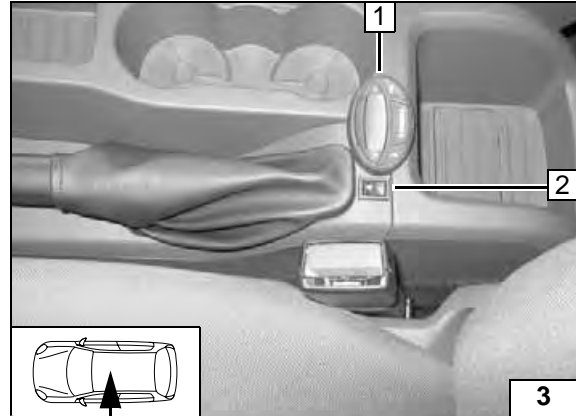

Fuse holder, relay K3

When drilling, watch components located behind.

- 2 K3 relay, 4 mm dia. hole, 5.5x13 self-tapping screw
- 3 Fuse holder, 4 mm dia. hole, 5.5x13 mm self-tapping screw
- 1 Wiring harnesses routed to right and fastened with cable ties

Connection to battery

Route wires (1) to left and fasten with cable ties.

- 2 Ground wire on negative battery terminal
- 3 Positive wire on positive battery terminal



Diagram of wiring harness routing for Focus





Electrical Connection on Focus/Focus CC from 2008

Wiring harness pass through

1 Protective rubber plug detached

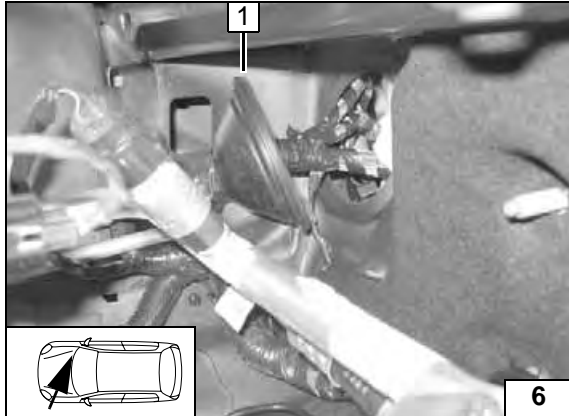

Digital timer

1 Digital timer

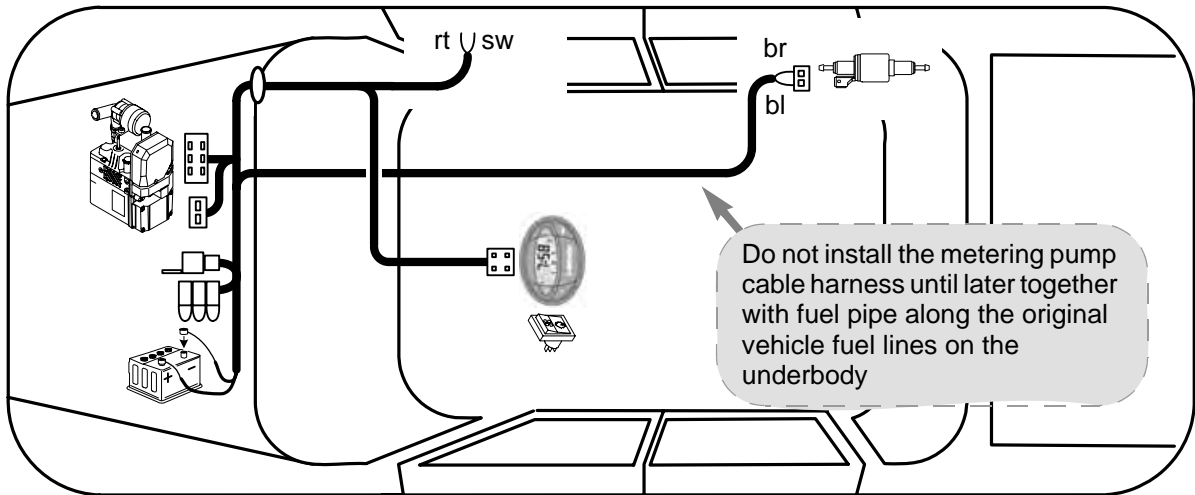
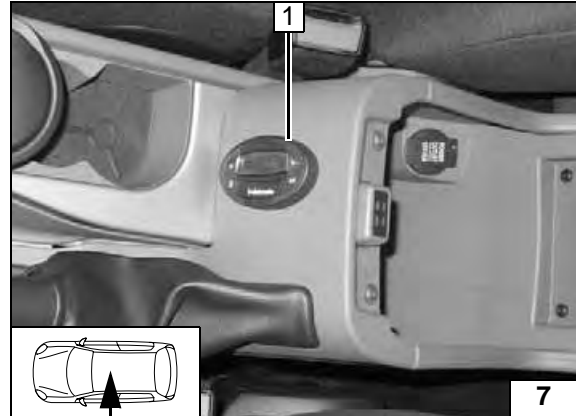
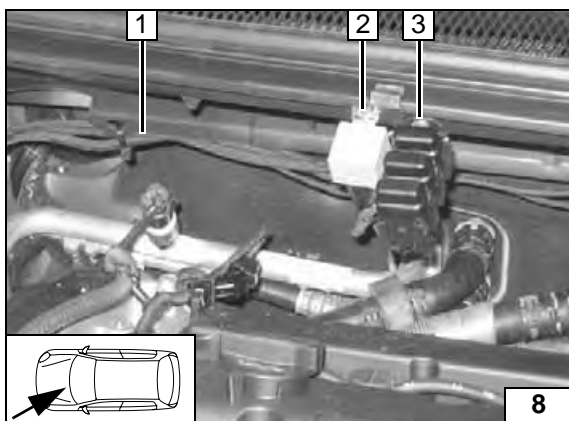

Diagram of wiring harness routing for Focus



Fuse holder, relay K3

When drilling, watch components located behind!

- 2 K3 relay, 4 mm dia. hole, 5.5x13 self-tapping screw
- 3 Fuse holder, 4 mm dia. hole, 5.5x13 mm self-tapping screw
- 1 Wiring harnesses routed to right and fastened with cable ties

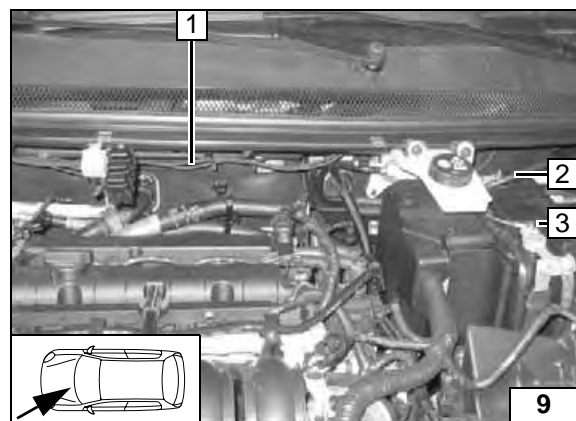

Connection to battery

Route wires (1) to left and fasten with cable ties.

- 2 Ground wire on negative battery terminal
- 3 Positive wire on positive battery terminal



Electrical Connection on C-MAX

Wiring harness pass through

- 1 Protective rubber plug detached

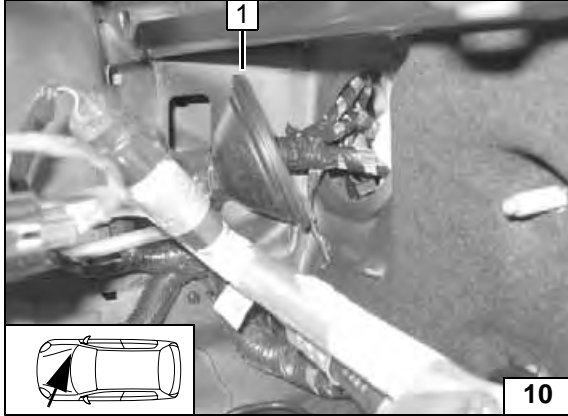

Digital timer

- 1 Digital timer
- 1 Summer/winter switch, drilled hole 12 mm dia.

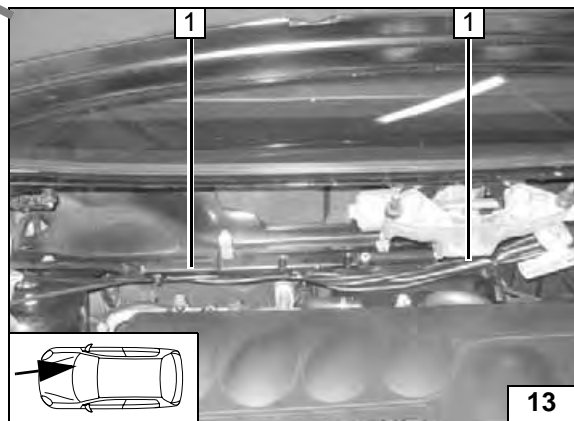
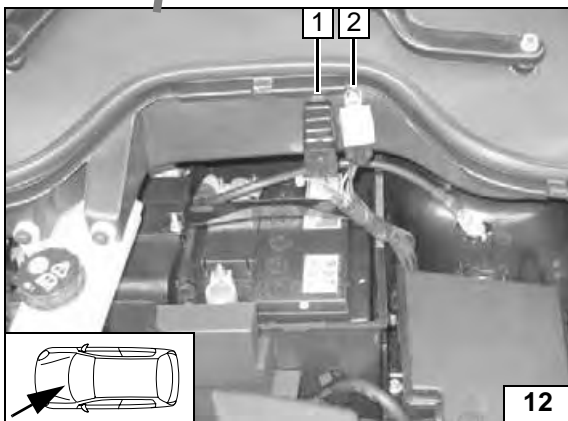
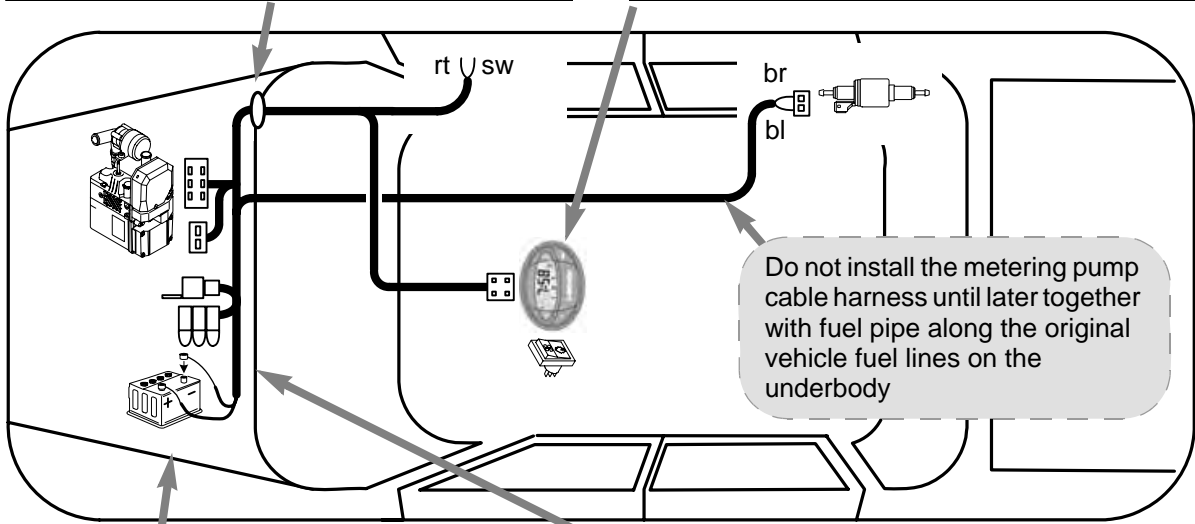
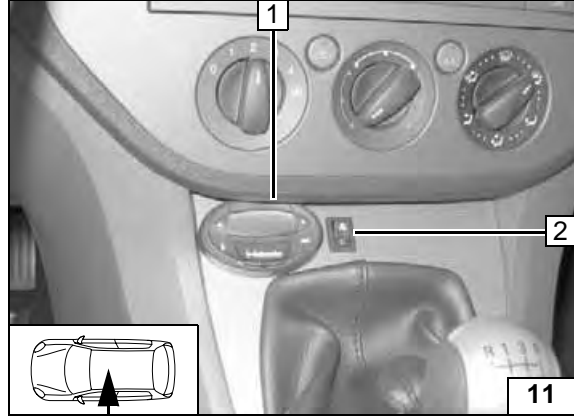

Fuse holder, relay K3

Fastening will not be carried out until later after reinstalling the coolant reservoir cap! When drilling, watch components located behind!

- 1 Fuse holder, 4 mm dia. hole, 5.5x13 mm self-tapping screw
- 2 K3 relay, 4 mm dia. hole, 5.5x13 self-tapping screw

Wiring harness routing

Connect ground wire to negative battery pole and positive wire to positive battery pole.

Route wiring harness (1) to right and fasten with cable ties as shown.



Wiring harness installation diagram for C-Max



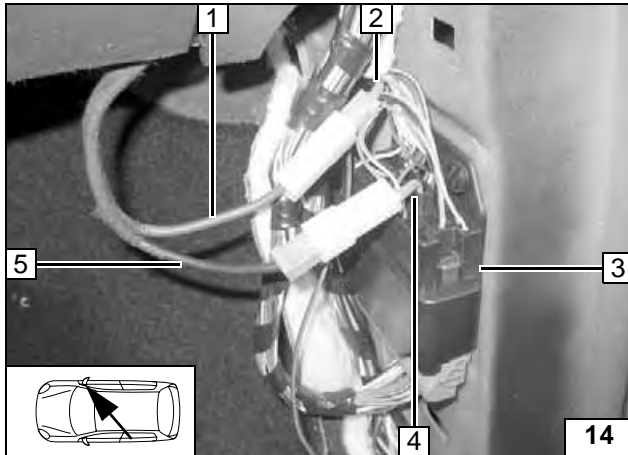

Fan Controller without Automatic Air-Conditioning

Connection is carried out on connector C111, Pin 22, at bottom of right-hand A-pillar. Produce connections as shown in wiring diagram with blade connectors provided.

- 3 Connector C111
- 1 Red (rt) wire to K3/87a
- 2 Green/orange (gn/or) wire from original vehicle fan relay K14
- 4 Wire to connector C111, Pin 22
- 5 Black (sw) wire from K3/30



**Connect-
ing fan
motor**



**Wiring dia-
gram with-
out
automatic
air-condi-
tioning**

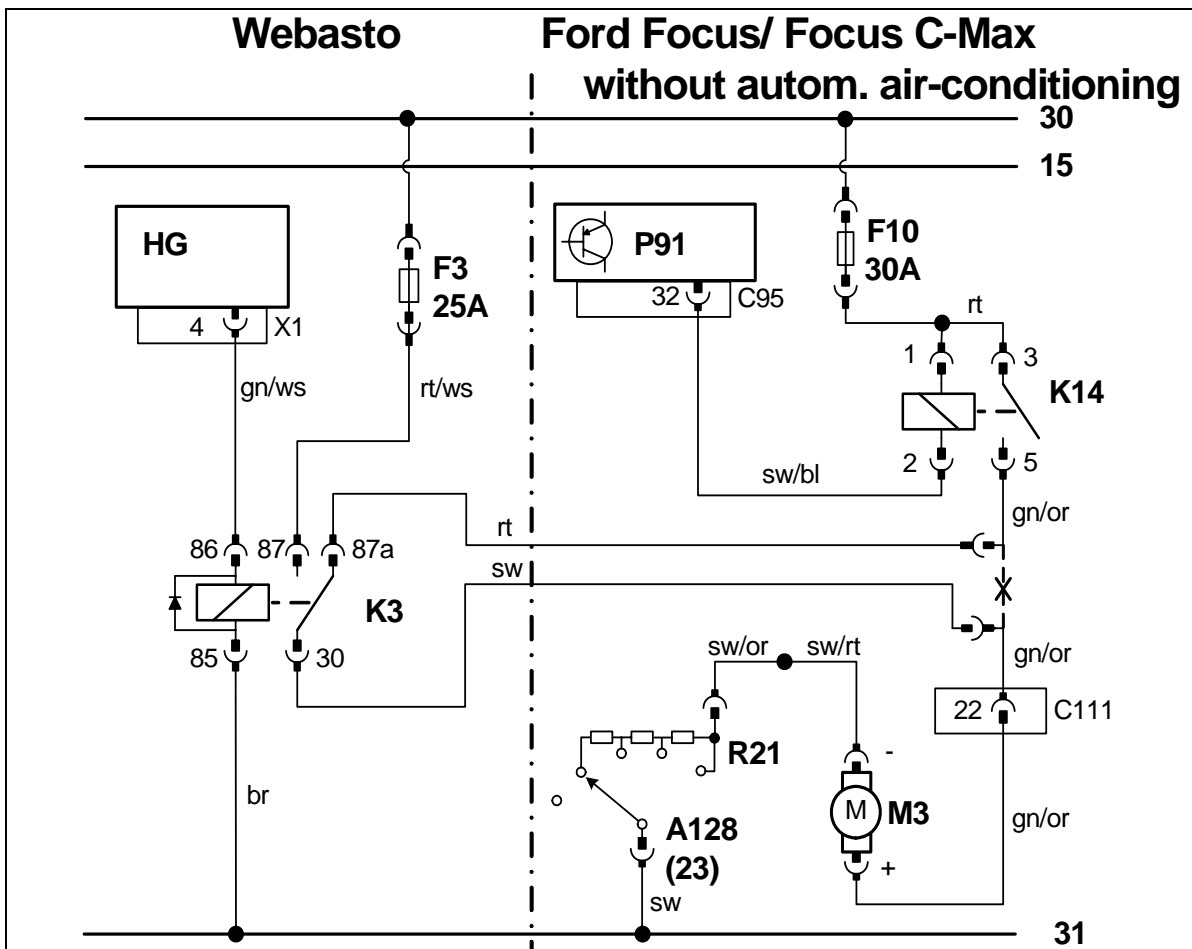

Webasto components		Ford components		Colors and symbols	
HG	Heater unit TT-C/E	F10	Fan fuse	rt	red
F3	Fan fuse	K14	Fan relay	ws	white
K3	Fan relay	P91	Central electrical box	sw	black
		C111	Connector on right-hand A-pillar	br	brown
		M3	Fan motor	gn	green
		R21	Resistor group	bl	blue
		A128	Heater control module	or	orange
		23	Fan switch		
				X	Cutting point

Legend

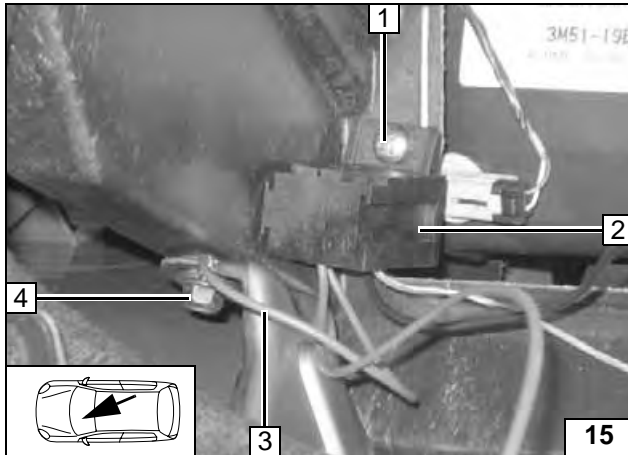

Fan controller with automatic air-conditioning

- 2 IPCU socket
- 1 4 mm dia. hole, 5.5x13 self-tapping screw
- 3 Brown (br) wire from IPCU/85
- 4 6 mm dia. cable lug, original vehicle bolt

IPCU fastening

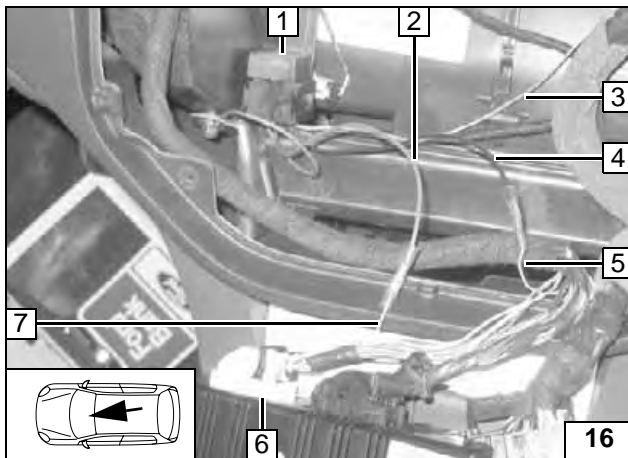

Connection is carried out on 26-pin connector C540, Pin 15.
Produce connections as shown in wiring diagram.

- 6 Connector C540
- 1 Connect IPCU
- 3 Green/white (gn/ws) wire from K3/86
- 4 Black (sw) wire from IPCU/A
- 5 Blue/white (bl/ws) wire to fan unit
- 7 Blue/white (bl/ws) wire from A/C control module
- 2 Red (rt) wire to IPCU/E

Connect-
ing air-
condition-
ing control
element

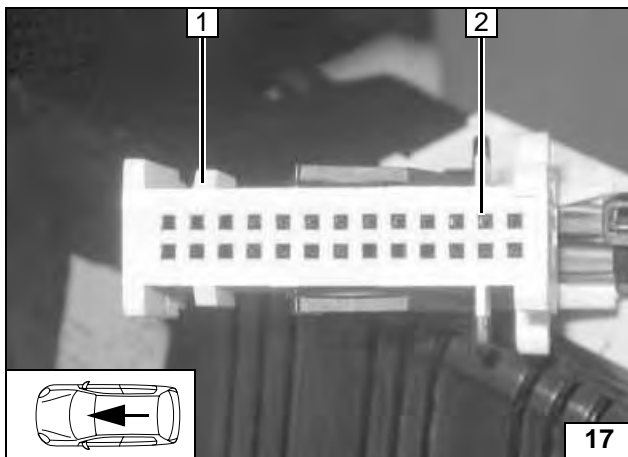

- 1 Connector C540
- 2 Pin 15

View of
connector

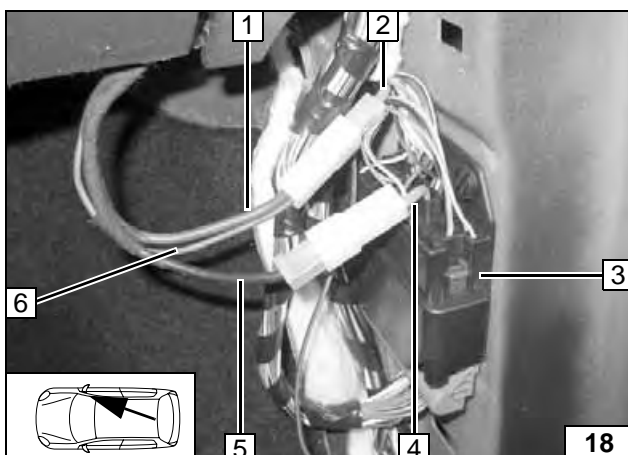

Connection is carried out on connector C111, Pin 22, at bottom of right-hand A-pillar.
Produce connections as shown in wiring diagram.
From 12/05, see page 12!

- 3 Connector C111
- 1 Red (rt) wire from K3/87a
- 6 Red (rt) wire from IPCU/15
- 2 Green/orange (gn/or) wire from original vehicle fan relay K14
- 4 Green/orange (gn/or) wire to connector C111, Pin 22
- 5 Black (sw) wire from K3/30 (on vehicles from 12/05, see page 12)

Connec-
tion to fan
unit

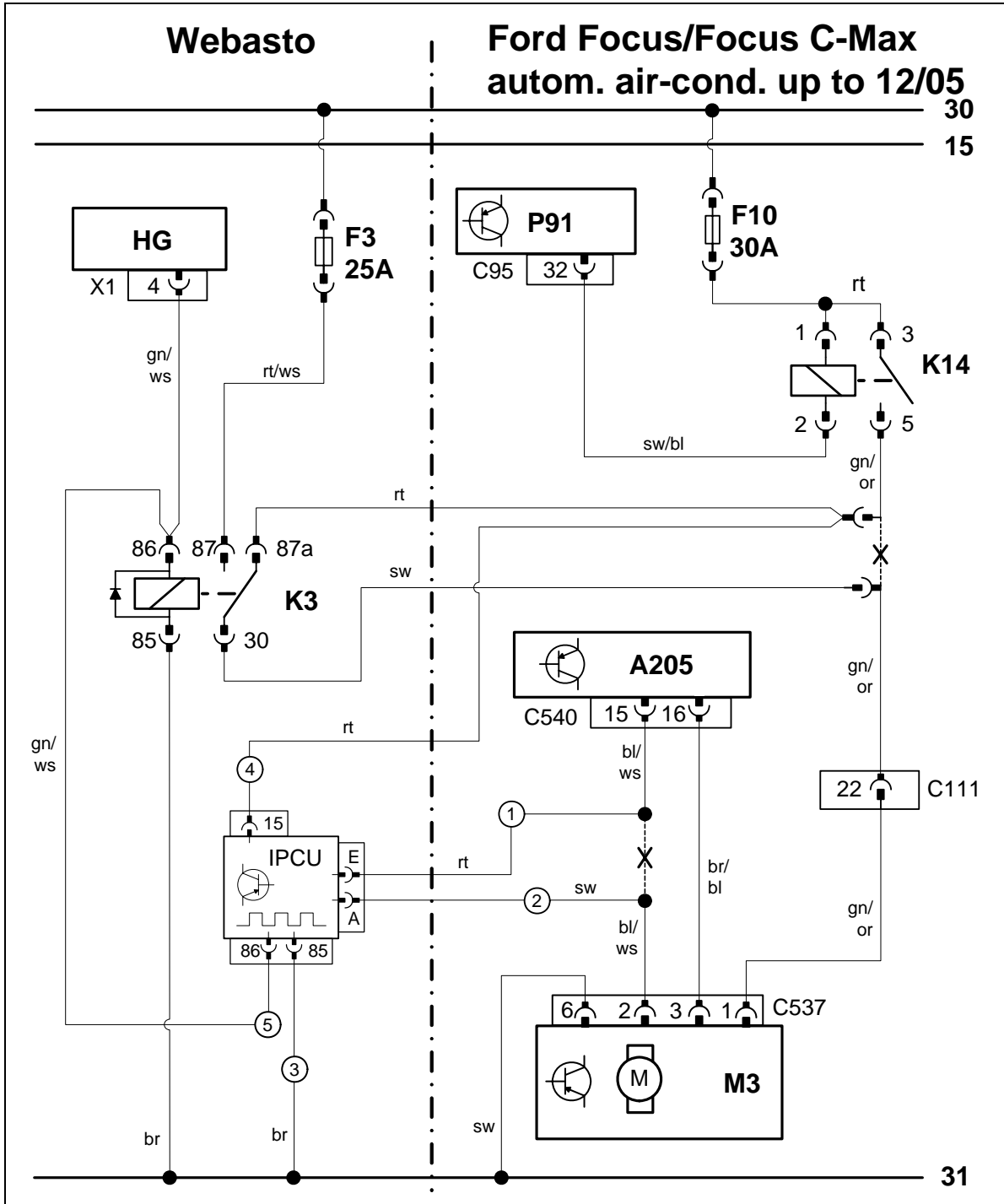

Wiring diagram for automatic air-conditioning

Webasto components		Ford components		Colors and symbols	
HG	Heater unit TT-C/E	F10	Fan fuse	rt	red
F3	Fan fuse	K14	Fan relay	ws	white
K3	Fan relay	C111	Connector on right-hand A-pillar	sw	black
IPCU	Intelligent Pulse Control Unit	P91	Central electrical box	br	brown
X1	Connector on heater unit	C95	Connector on P91	gn	green
		M3	Fan unit	bl	blue
		C537	Connector on M3	or	orange
		A205	A/C control module (EATC)		
		C540	Connector on A205		
				X	Cutting point

Legend

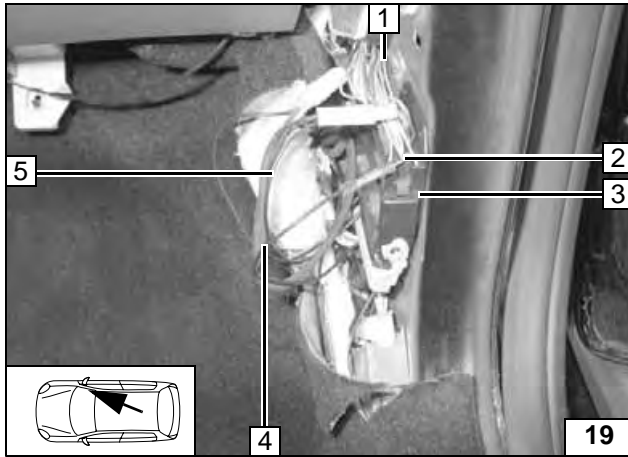

Additionally for automatic air-conditioning from 12/05

Produce connections as shown in wiring diagram.

- 1 Cut off green/orange (gn/or) wire of C111/3 and insulate
- 2 Green/orange (gn/or) wire of C111/3
- 3 Connector C111
- 4 Black (sw) wire of F4
- 5 Black (sw) wire of F4



Fan controller

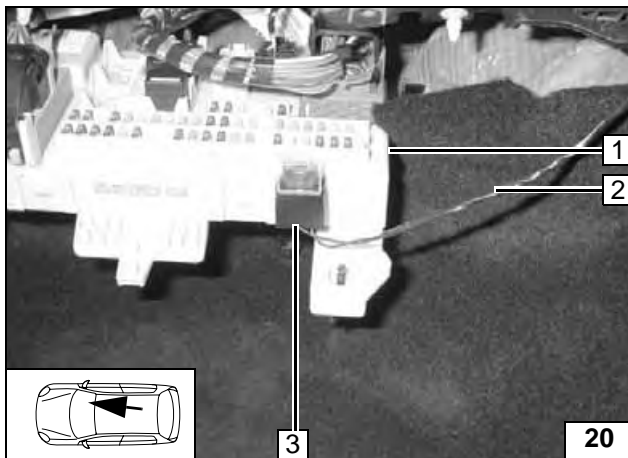

Complete fuse holder with materials provided and fasten it with double-sided adhesive tape.

Produce connections as shown in wiring diagram.

- 1 Central electrical box in right-hand footwell
- 2 Black (sw) wires, 500 mm
- 3 Fuse holder, 10 A fuse



Fuse F4

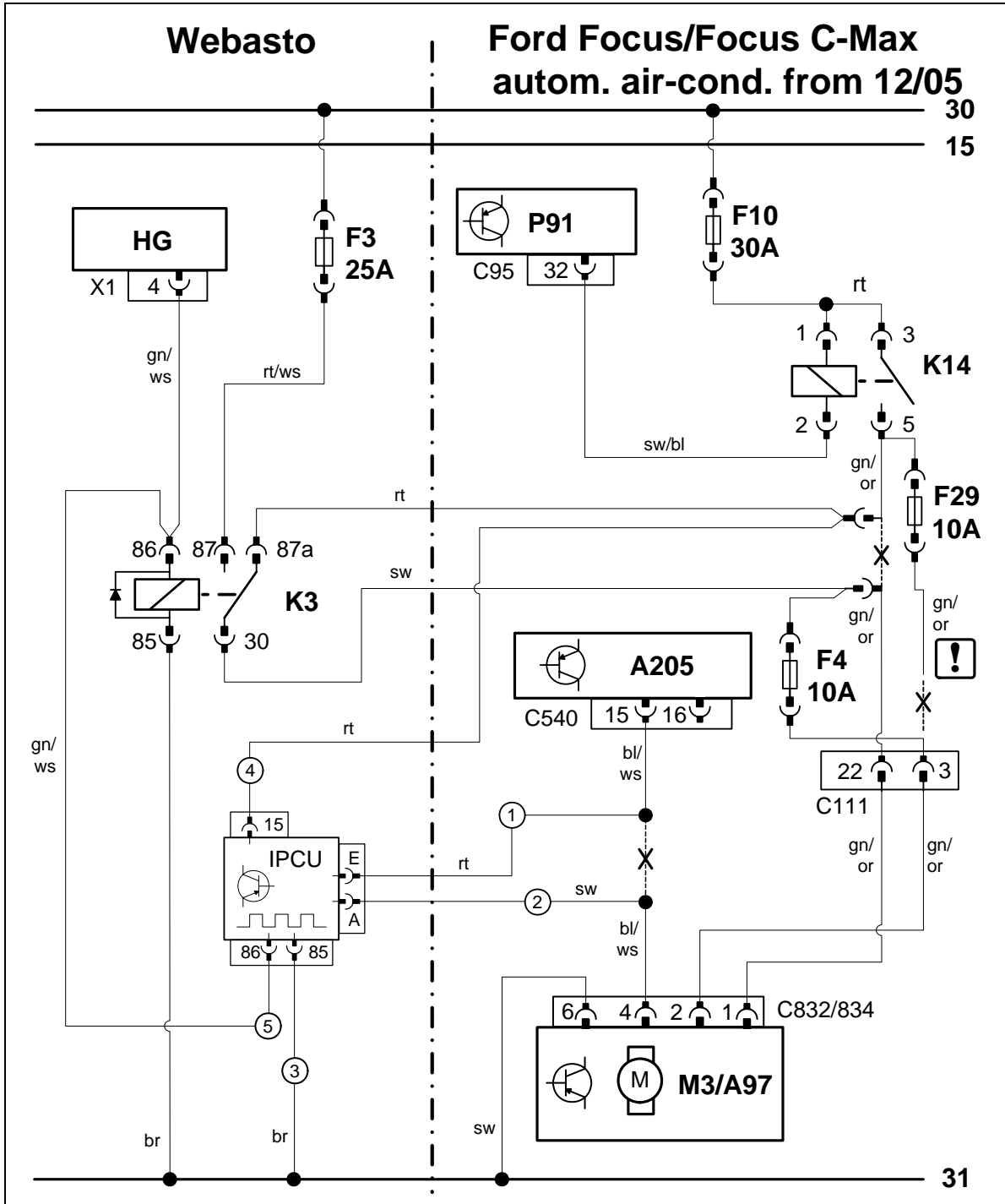

Wiring diagram for automatic air-conditioning

Webasto components		Ford components		Colors and symbols	
HG	Heater unit TT-C/E	F10	Fan fuse	rt	red
F3	Fan fuse	K14	Fan relay	ws	white
K3	Fan relay	C111	Connector on right-hand A-pillar	sw	black
IPCUC	Intelligent Pulse Control Unit	P91	Central electrical box	br	brown
X1	Connector on heater unit	C95	Connector on P91	gn	green
F4	10 A fuse	M3	Fan unit	bl	blue
		C832/834	Connector on M3/A97	or	orange
		A205	A/C control module (EATC)	!	Insulate wire ends and tie back
		C540	Connector on A205	X	Cutting point

Legend

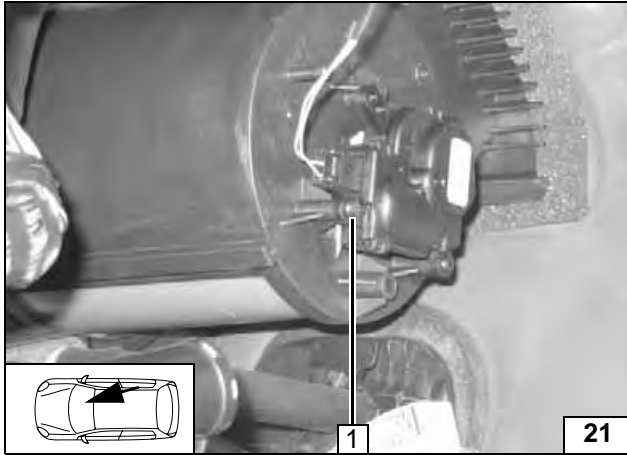

Remote option (Telestart)

Receiver is mounted on existing bolt on positioning motor.

- 1 Original vehicle bolt



Installation location of receiver

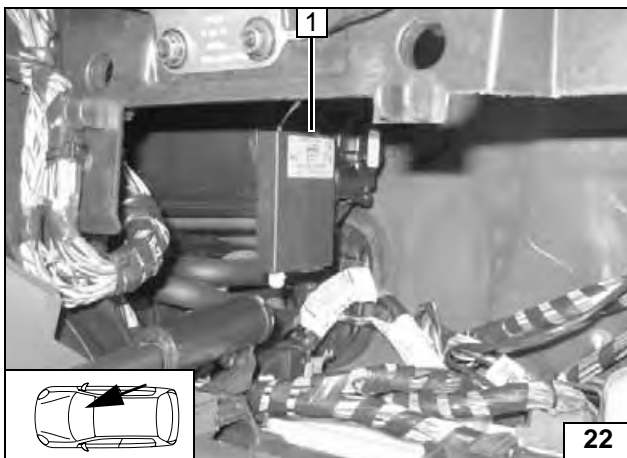

- 1 Receiver

Installing receiver

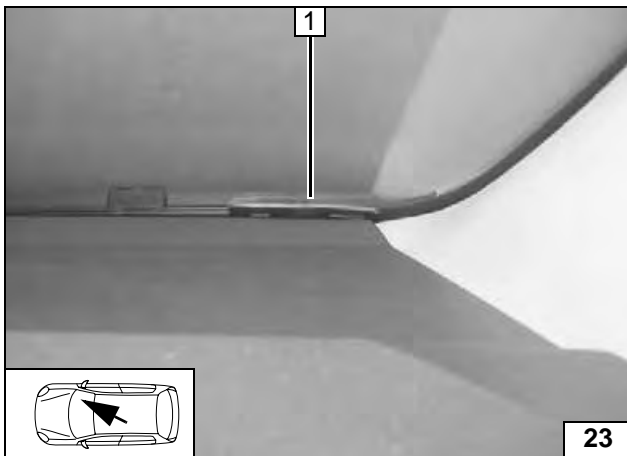

- 1 Antenna

Installing antenna



Thermo Call Option on Focus

Countersink holes (1) for M4 countersunk head screws from inside.

- 2 Receiver,
- 1 4.5 mm dia. hole, M4x10 countersunk head screw (from inside), nut [2x]
- 3 Self-adhesive Velcro strip as rattle protection



Installing receiver

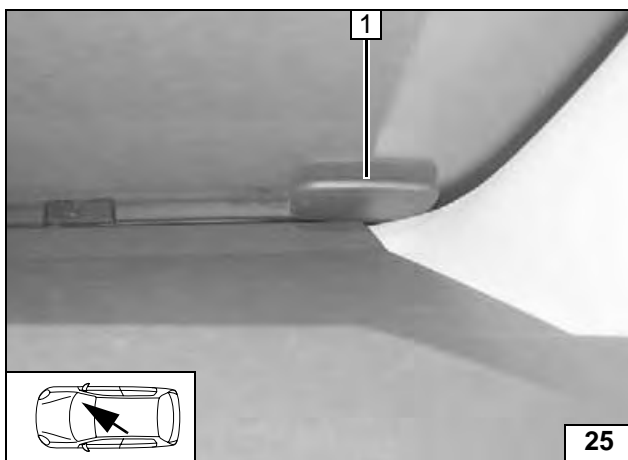

- 1 Antenna

Installing antenna

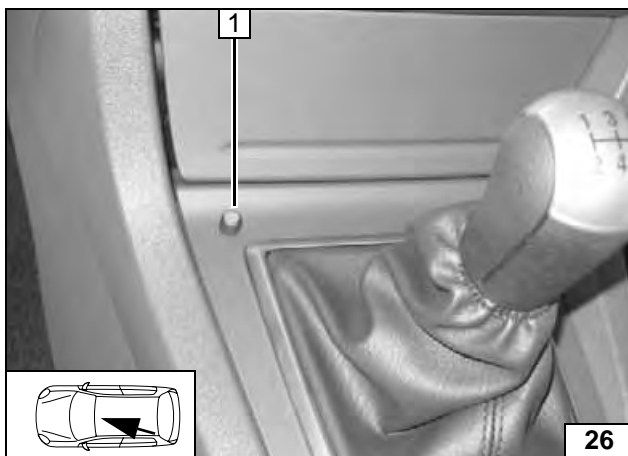

- 1 Pushbutton

Installing push button

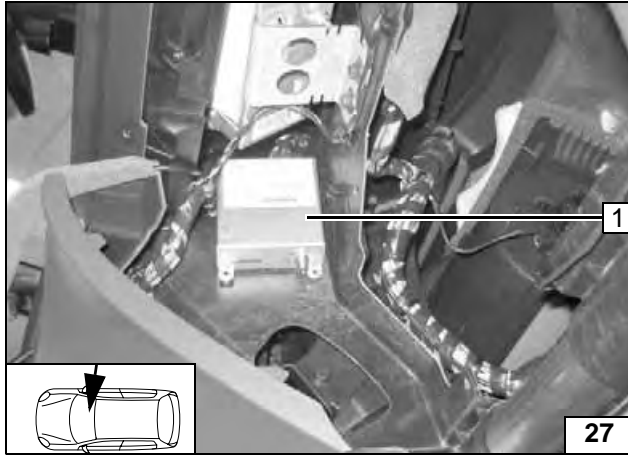

Thermo Call Option on C-MAX

2 Receiver, self-adhesive Velcro strip



Installing receiver

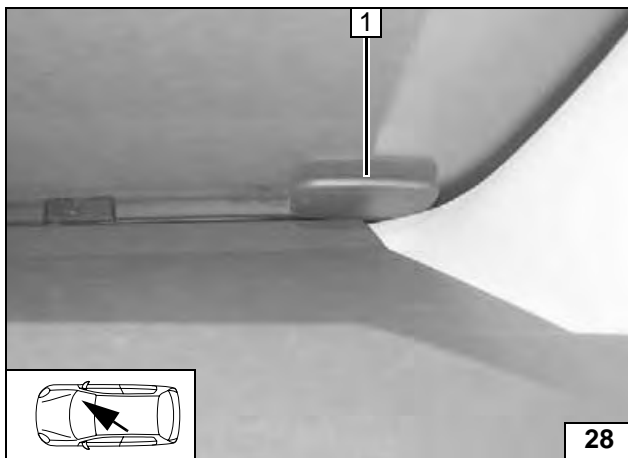

1 Antenna

Installing antenna

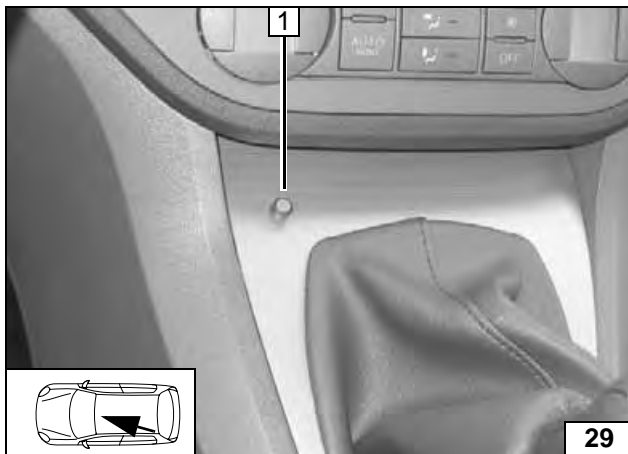

1 Pushbutton

Installing push button

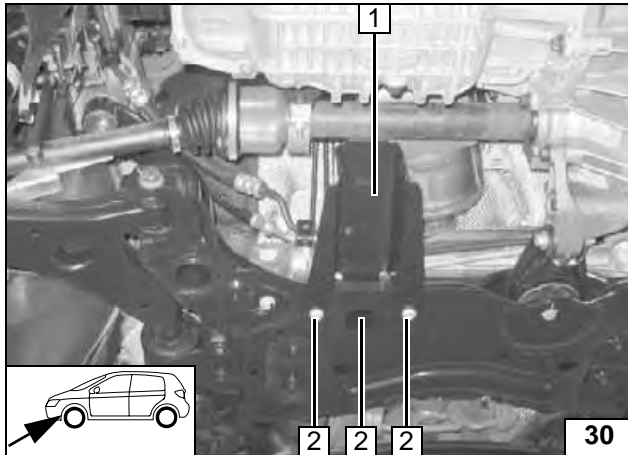
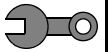

Preparing installation location

Cross member is dependent on vehicle equipment!

- 1 Cross member
- 2 M10 bolts [3x]



Removing cross member

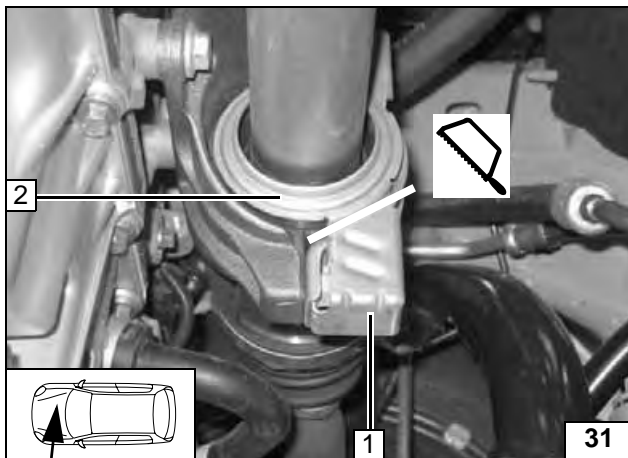

Design of guard plate (2) is dependent on vehicle equipment!

- 1 Remove section and discard



Adapting guard plate

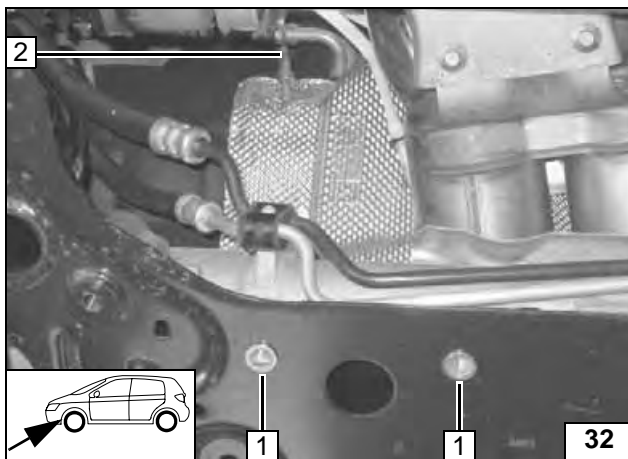

If threaded inserts are not present at position (1), then mount M10 rivet nuts provided in hexagon holes.

Use special tool as shown on Page 3. For alternative, see next illustration.

- 1 M10 steel rivet nut [2x]
- 2 Stud bolt



Installing rivet nut

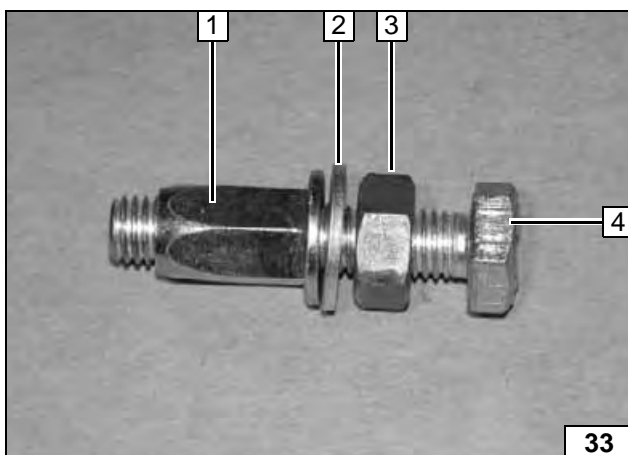

- 1 M10 rivet nut (steel)
- 2 Washer
- 3 M10 nut
- 4 M10 bolt



Alternative rivet-down tool

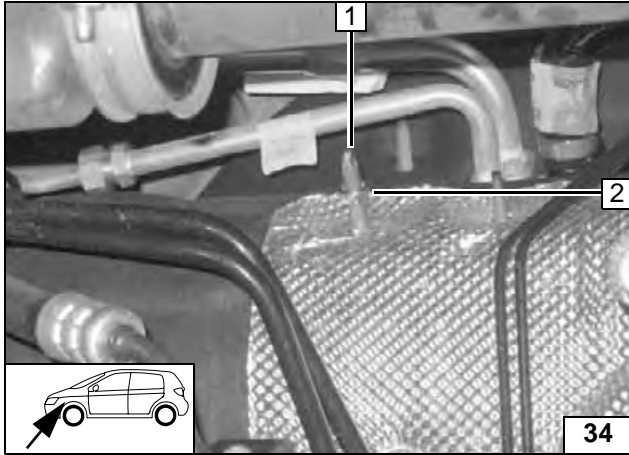
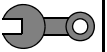

Screw on flanged nut with flange toward front.

- 1 Original vehicle stud bolt
- 2 M8 flanged nut



**Preparing
installa-
tion loca-
tion**



Preparing coolant connection

WARNING!

Install hoses so that they are kink-free. Unless specified otherwise, always fasten using cable ties. Position spring clips so that no other hose can be damaged! The connection should be "inline" based on the following diagram:

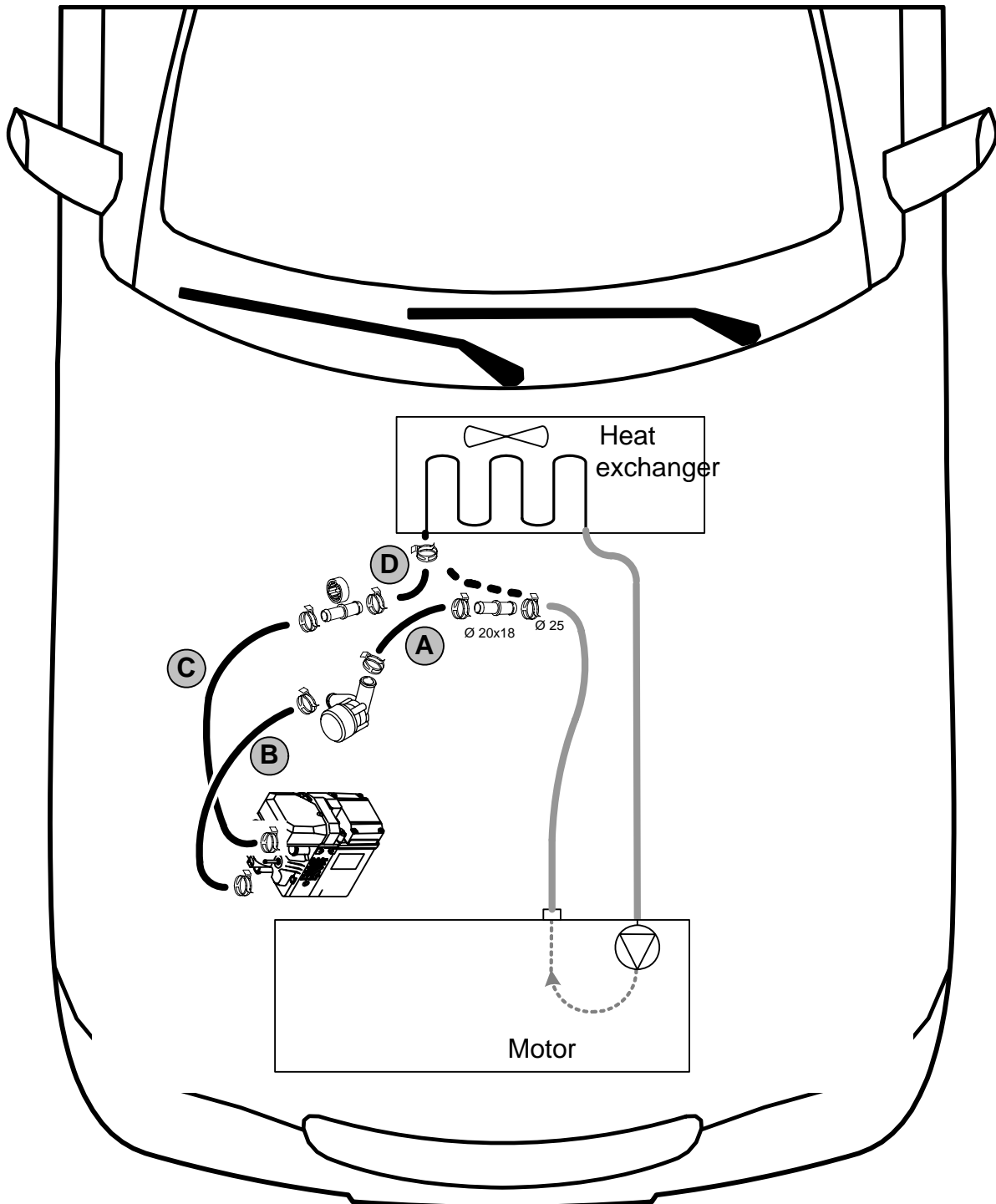

Coolant routing diagram

All clamps without a specific designation = 27 mm dia. spring clips!
 All connecting pipes without a specific designation are dia. 20x20!

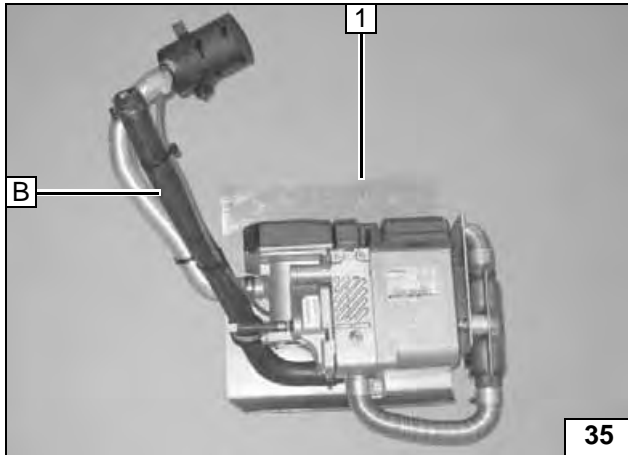
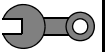

Premounting heater unit

1 Delivered heater unit assembly



Heater unit assembly

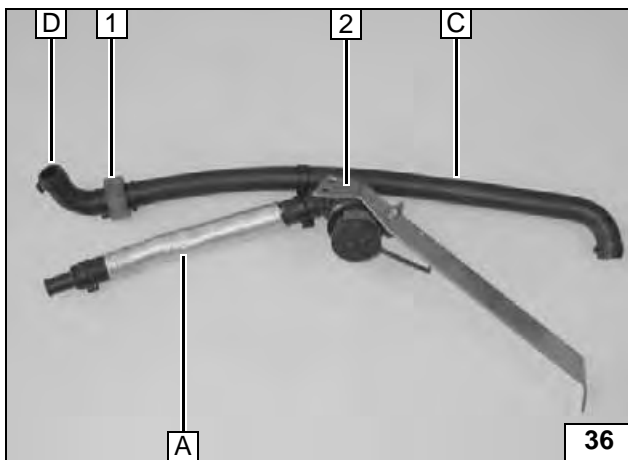

2 Delivered coolant assembly

1 Black (sw) rubber profile positioned in center between spring clips



Coolant assembly

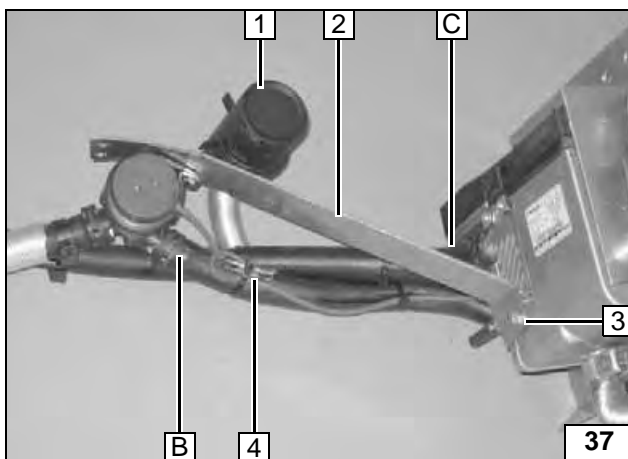

Hole in corner of strut is used at Position (3)! Only loosely mount E-jot screw (3) so that strut (2) can still be aligned during installation.

1 Retaining clip with intake muffler engaged in hole

4 Wiring harnesses for circulating pump connected with same colors (crimp and shrink)



Connect-
ing as-
semblies

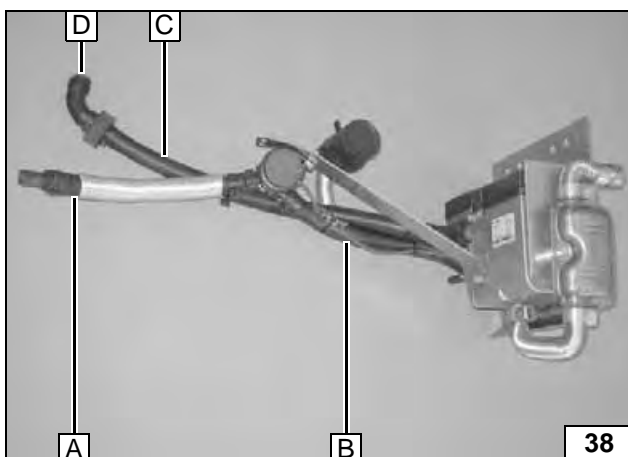

General view

Fix hoses B and C and wiring harness of circulating pump in place with cable ties.



Connect-
ing as-
semblies

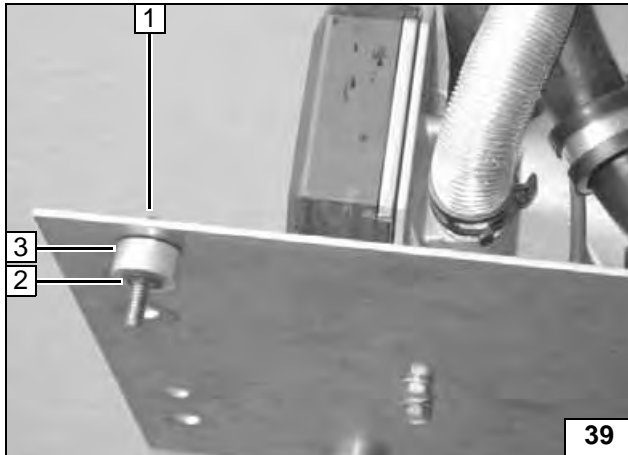
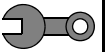

Fastening for Underride Protection

Vehicle-dependent, if present!

- 1 M6x25 bolt in existing 7 mm dia. hole
- 3 10 mm shim
- 2 Pin lock

Premounting heater unit

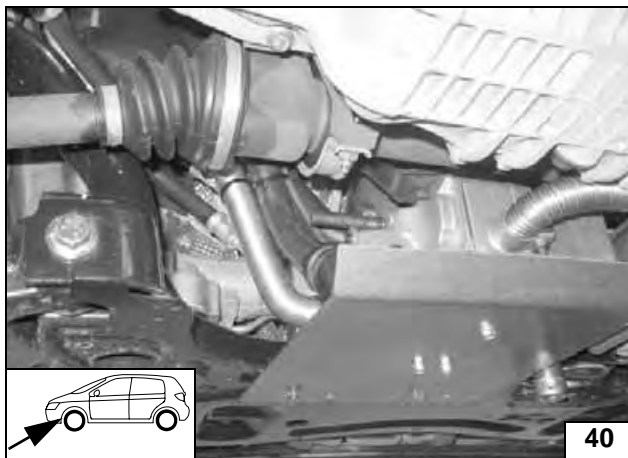

Installing heater unit

Only for 1.4 liter; 1.6 liter; 1.8 liter engine

Guide heater unit to installation location and connect wiring harness as shown.

Installing heater unit

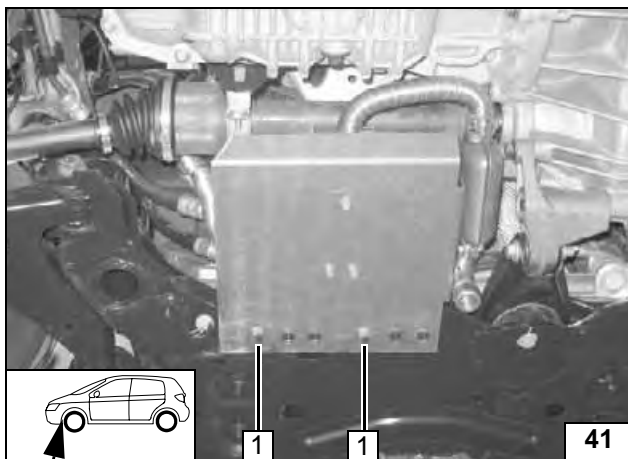

Use holes in bracket as shown. Check position of all components and adjust if necessary. Check that they have free clearance.

- 1 M10x30 bolt with locking tothing [2x]

Installing heater unit

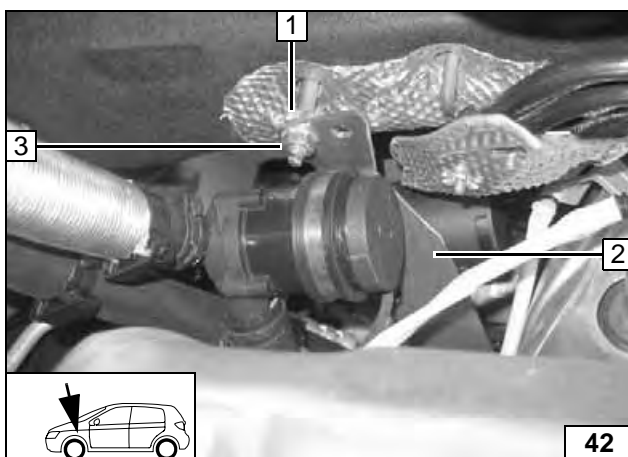

Use hole in strut as shown. Check position of all components and adjust if necessary. Check that they have free clearance.

- 1 M8 flanged nut (premounted)
- 3 Flanged nut
- 2 Strut

Installing heater unit



Tighten Eجت screw (10 Nm).



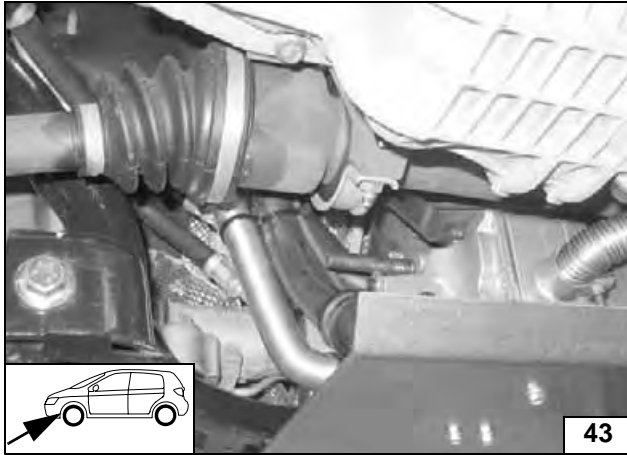
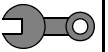

Only for 2.0 liter engine

Guide heater unit to installation location and connect wiring harness as shown.



Installing heater unit

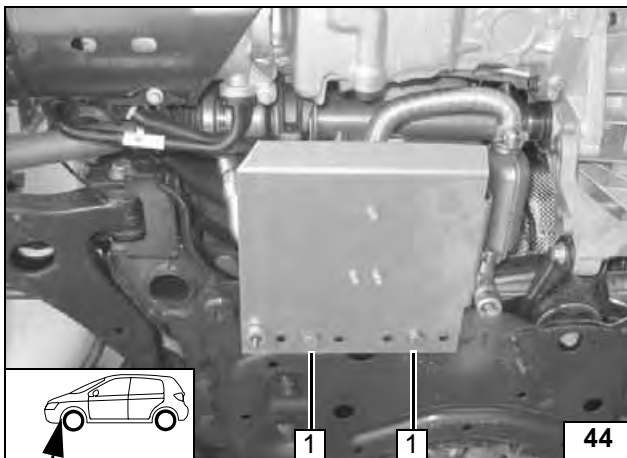

Use holes in bracket as shown. Check position of all components and adjust if necessary. Check that they have free clearance.

- 1 M6x30 bolt, spring lockwasher [2x]



Installing heater unit

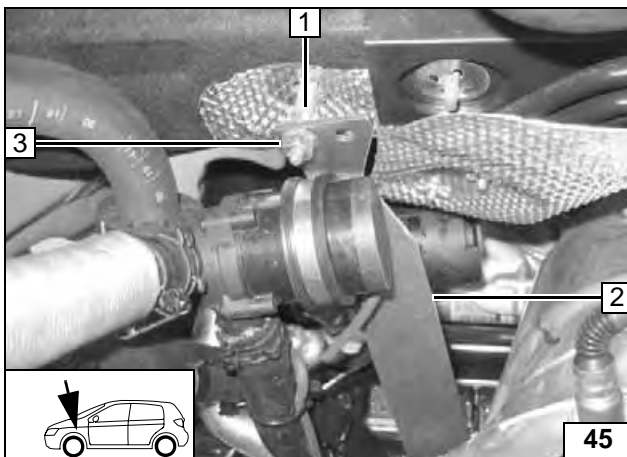

Use hole in strut as shown. Check position of all components and adjust if necessary. Check that they have free clearance.

- 1 M8 flanged nut (premounted)
- 3 Flanged nut
- 2 Strut



Installing heater unit

Tighten Ejet screw (10 Nm).





Coolant connection

WARNING!

Any coolant running off should be collected using an appropriate container!
 Install hoses so that they are kink-free. Unless specified otherwise, always fasten using cable ties.
 Position spring clips so that no other hose can be damaged!
 The connection should be "inline" based on the following diagram:

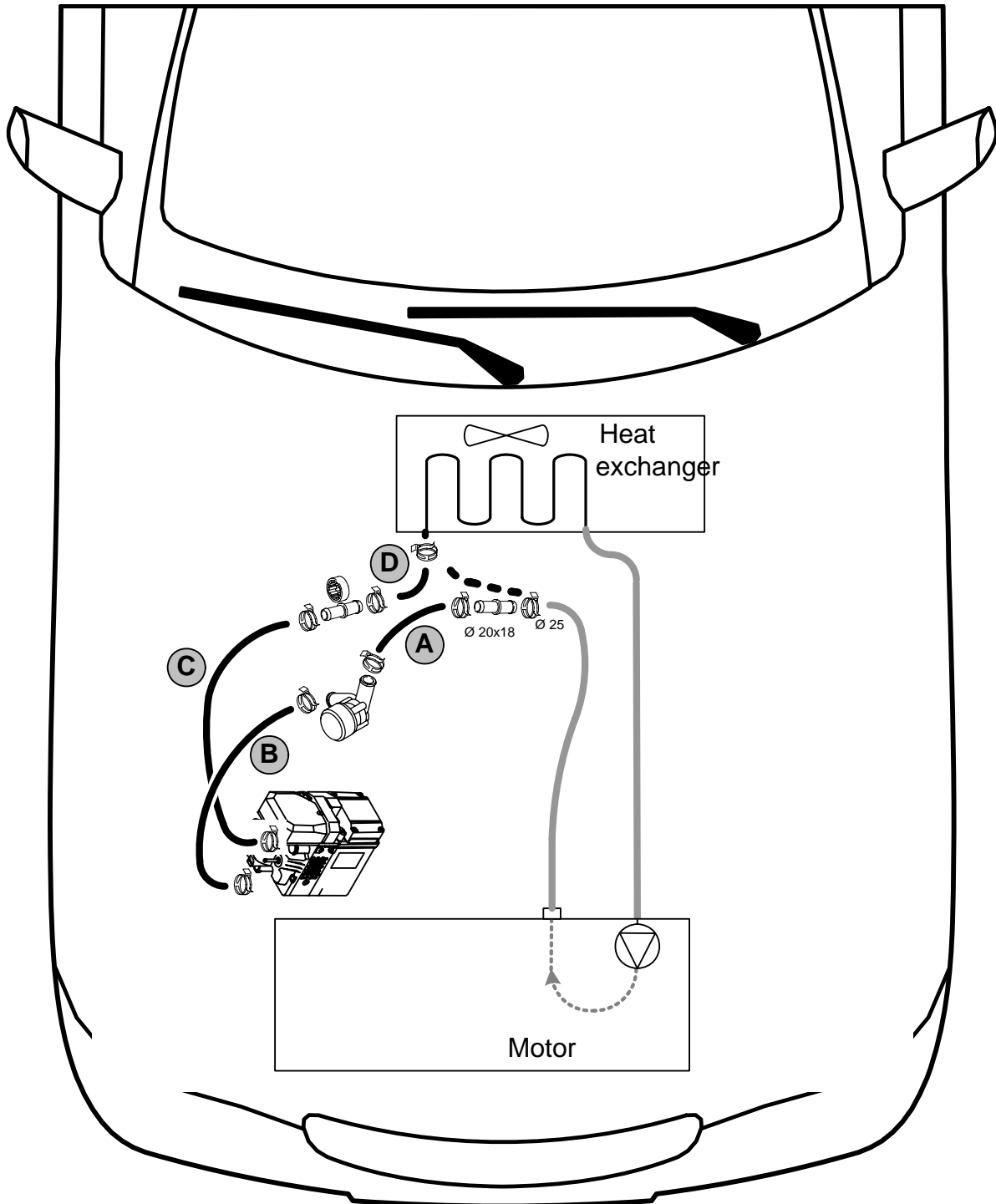

Coolant routing diagram

All clamps without a specific designation = 27 mm dia. spring clips!
 All connecting pipes without a specific designation are dia. 20x20!

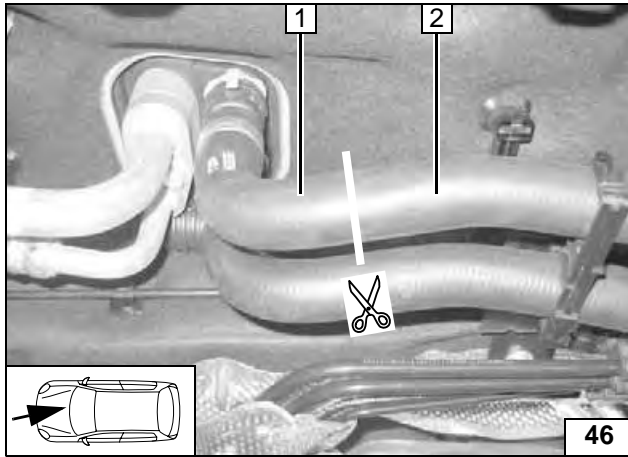

- 1 Hose section of heat exchanger inlet
- 2 Engine outlet hose section

Cutting point



Remove connection piece according to manufacturer's instructions. Locking device (3) must be turned counterclockwise for this purpose.

- 2 Carefully saw open clamp
- 1 Discard hose



Preparing coolant

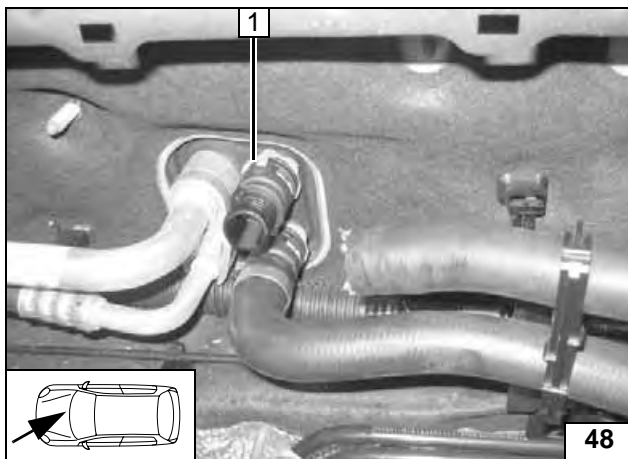

- 1 Connection piece of heat exchanger inlet mounted and locked

Preparing coolant

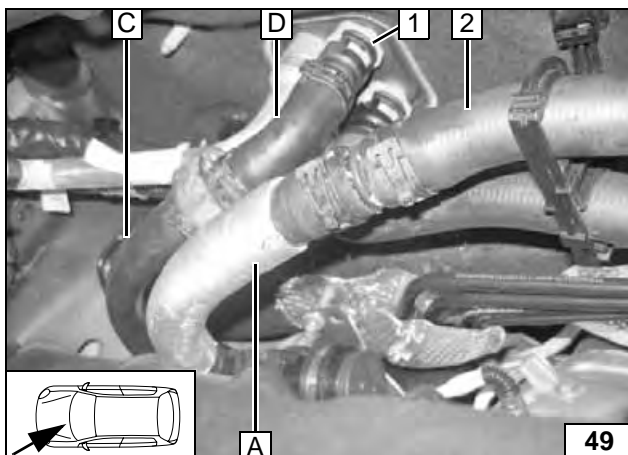

Before connecting, fill the coolant hoses with coolant.

- 1 Connection piece of heat exchanger inlet
- 2 Engine outlet hose section

Connect-
ing hoses

Check routing of hoses and correct if necessary. Fasten wiring harness of heater unit to coolant hoses with cable tie.





Fuel Connection

CAUTION!

Open the vehicle's fuel tank cap, ventilate the tank and then re-close the tank lock.

Catch any fuel running off with an appropriate container.

Install fuel line and metering-pump wiring harness so that they are protected against stone impact. Unless specified otherwise, always fasten using cable ties.

Mount the fuel line and wiring harness with rub protection on sharp edges.

WARNING!

The fuel line and wiring harness are routed to the metering pump in as shown in the wiring harness routing diagram.

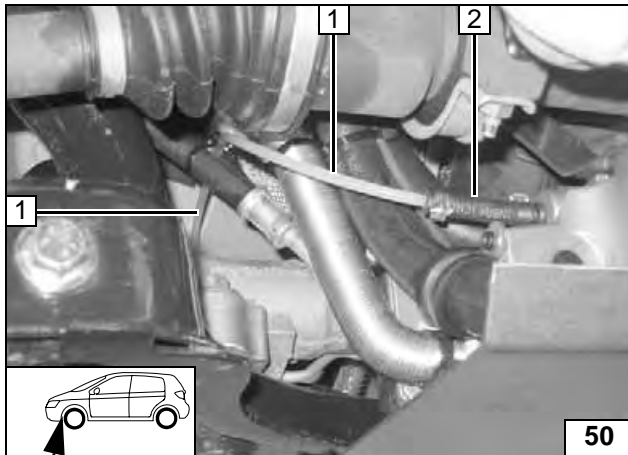

- 1 Mecanyl fuel line
- 2 10 mm dia. Caillau clamp

Route mecanyl fuel line to firewall and fasten with cable ties as shown. Pay particular attention to sufficient distance to propeller shaft!

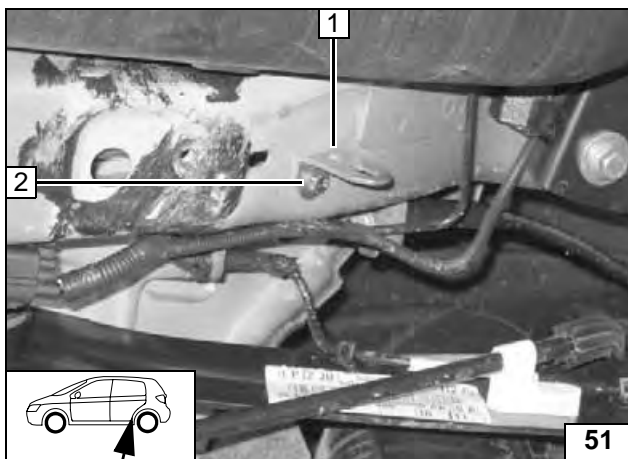

Installation location on right next to vehicle fuel tank.

- 1 Angle bracket
- 2 M6x20 bolt, spring lockwasher on existing thread insert

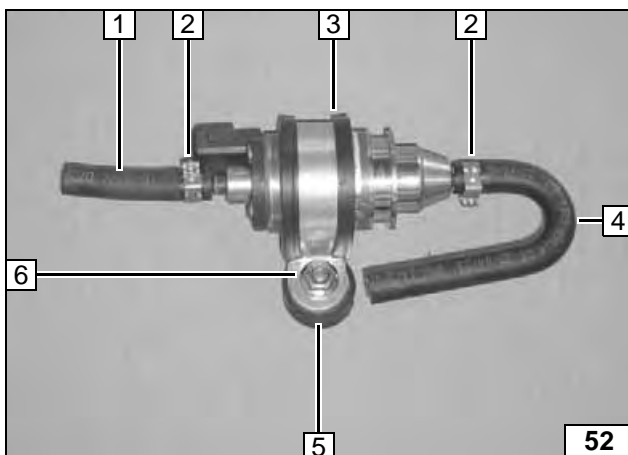

- 1 Hose section
- 2 10 mm dia. Caillau clamp [2x]
- 4 180° molded hose
- 3 Rubber-coated pipe clamp
- 5 Silentblock
- 6 Flanged nut



Conne-
ction on
heater unit



Installa-
tion loca-
tion of
metering
pump

Premount-
ing meter-
ing pump

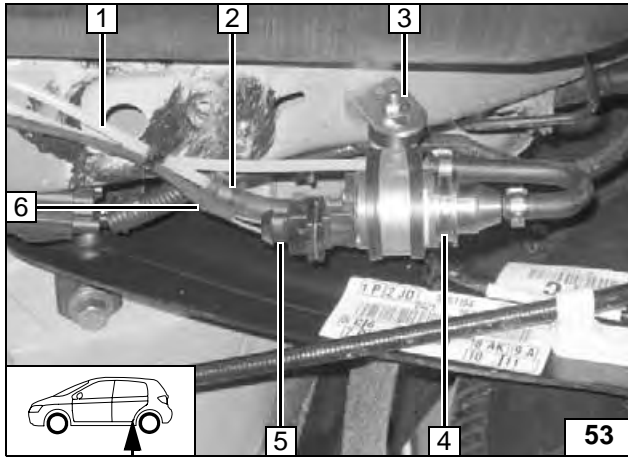

Slide metering pump as far as possible upward in oblong hole.
Route fuel line and wiring harness as shown in following illustration.
Fuel line to heater unit on pressure side of metering pump [side with connector].

- 4 Premounted metering pump
- 3 Flanged nut
- 1 Mecanyl fuel line
- 2 10 mm dia. Caillau clamp
- 6 Metering pump wiring harness
- 5 Completed connector housing

Installing metering pump

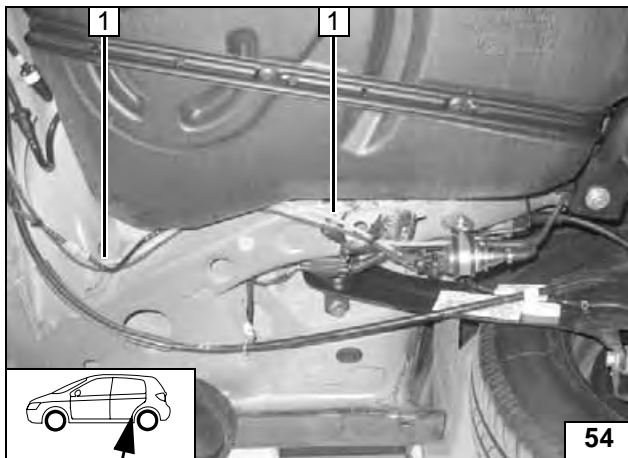

- 1 Mecanyl fuel pipe and metering pump cable harness

Wiring routing

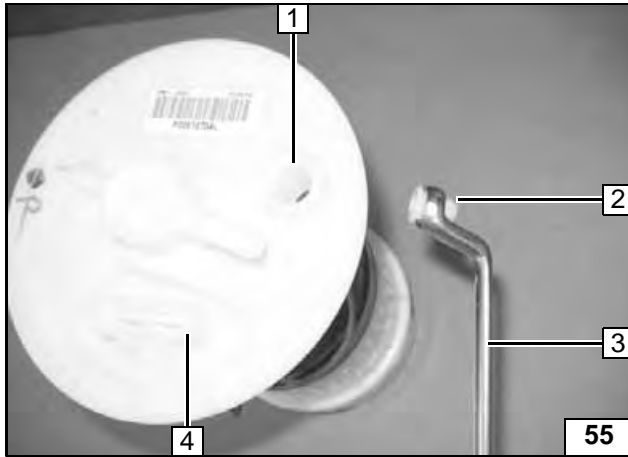

Removing fuel

Remove fuel-tank sending unit (4) in accordance with manufacturer's specifications.
Break out connection piece (2) at rupture joint (1) with suitable tool (3) according to manufacturer's instructions.



Removing fuel

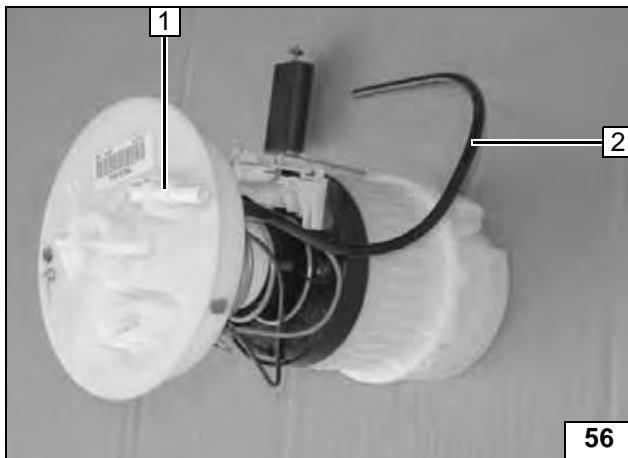

Install fuel standpipe (Ford Order No. Finis Code 1233999) according to manufacturer's instructions.

- 1 Fuel standpipe
- 2 Removal hose



Installing fuel standpipe

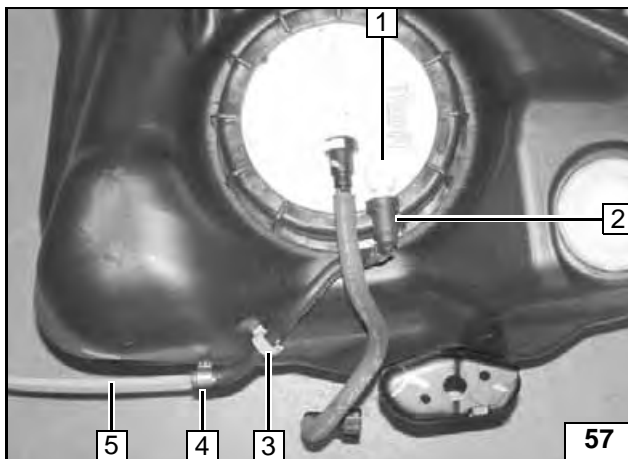

Align removal hose up to bottom of fuel tank. Ensure freedom of movement of fuel gauge.

Install fuel-tank sending unit according to manufacturer's specifications. Mount coupling and align; remove clip at Position 3.

- 1 Fuel standpipe
- 2 Coupling piece, mounted on fuel standpipe
- 5 Mecanyl fuel line
- 4 10 mm dia. Caillau clamp
- 3 Clip

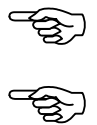

Connecting fuel line

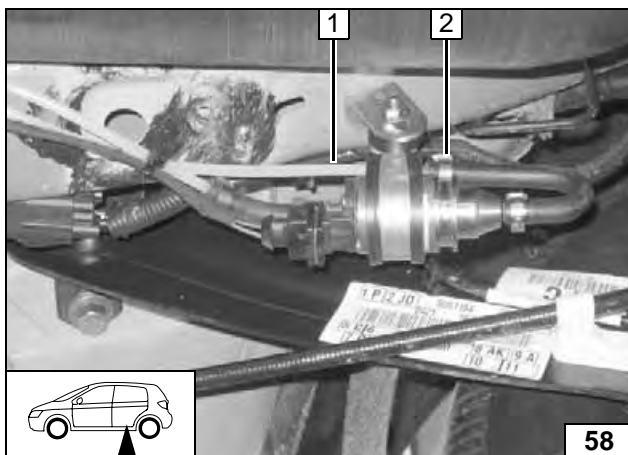

Reinstall fuel tank.

Fuel line from fuel standpipe on intake side of metering pump [side without connector].

- 1 Fuel line
- 2 10 mm dia. Caillau clamp

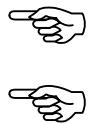

Connection to metering pump

Check the position of the components; adjust if necessary. Check that they have free clearance.

Align fuel lines and wiring harness of metering pump over entire length and secure with cable ties



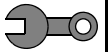

59

Mounting underride protection

For all vehicles!

Underride protection is dependent on vehicle equipment!

Cut out underride protection as shown.



Cutting out underride protection

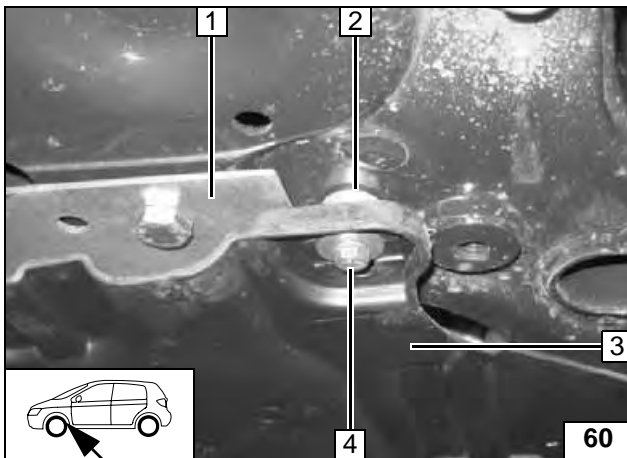

60

Only for 1.4 liter; 1.6 liter; 1.8 liter engine!

Remove plastic threaded insert.

Drill out hole to 9 mm dia. and insert M6 rivet nut.

- 1 Bracket of heater unit
- 2 M6 rivet nut, 10 mm shim
- 3 Underride protection
- 4 M6x40 bolt, spring lockwasher, large diameter washer



Installing underride protection for 1.4 liter; 1.6 liter; 1.8 liter engine

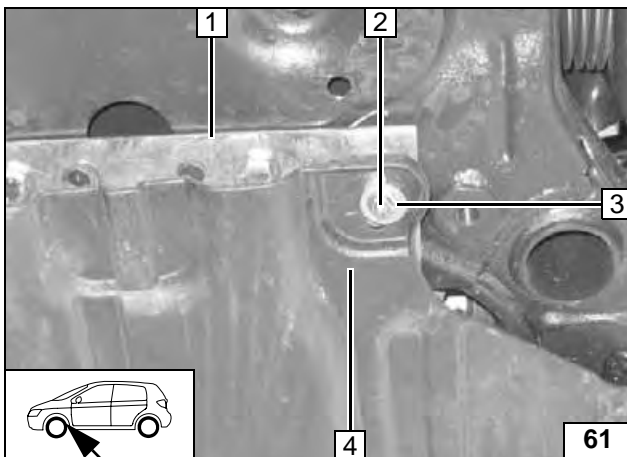

61

Only for 2.0 liter engine!

- 1 Bracket of heater unit
- 2 Pre-mounted bolt
- 3 M6 flanged nut, large diameter washer
- 4 Underride protection



Installing underride protection for 2.0 liter engine

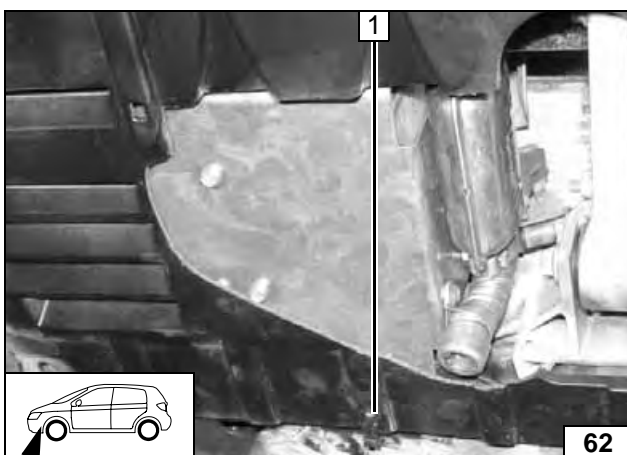

62

For all vehicles!

Photo shows 1.8 liter

Check positioning of underride protection! In particular, ensure sufficient distance to heater-unit exhaust system! Rework cut-out if necessary.

Also fasten underride protection for stabilization with cable ties at position (1).



Installing underride protection for all vehicles

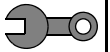

Final Work

WARNING!

Reassemble the disassembled components in reverse order.

Check all hoses, hose, spring and Caillau clamps, as well as all electrical connections for firm seating.

Secure all loose cables using cable ties.

Only use manufacturer-approved coolant.

Spray the heater unit components with anti-corrosion wax (Tectyl 100K, Order No. 111329).

- Connect battery
- Bleed and fill the coolant circuit according to the vehicle manufacturer's specifications.
- Set the digital timer.
- Adjust the vehicle heater with automatic air-conditioning or without automatic air-conditioning according to "Operating Instructions for End Customer".
- Check the proper operation of the additional heater, see the operating instructions/installation instructions.
- Attach the "Switch off additional heater before refueling" sticker to the left-hand B-pillar.



Webasto AG
Postfach 80 - 82132 Stockdorf, Germany - Hotline +49-
(0)1805-932278

Operating Instructions for End Customer



Please remove page and add to the vehicle operating instructions.

Note: On vehicles with "Flexyfuel engine, operation of additional heater is only permissible with gasoline!

Before parking the vehicle, make the following settings:

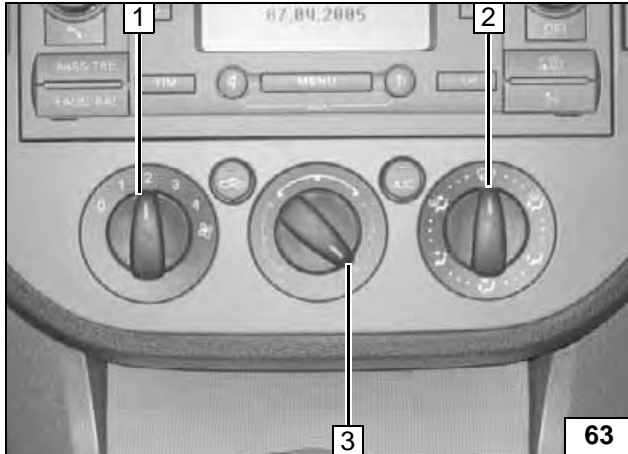

- 1 Set fan to level "2", or possibly "1"
- 2 Air outlet to windshield
- 3 Set temperature to "max."

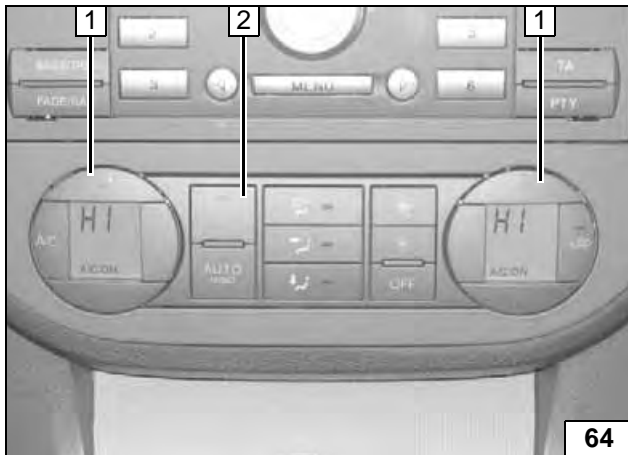

- 1 Temperature to "max." [2x]
- 2 Air outlet to windshield



- 1 Temperature to "max." [2x]
- 2 Air outlet to windshield

For vehicles without automatic air-conditioning

For vehicles with automatic air conditioning

For vehicles with automatic air conditioning