

## Thermo Top C Motorcaravan Additional Heater e1 00 0002

## Installation Instructions

### Iveco Daily

Diesel  
from Model Year 2006  
For left-hand drive vehicles only



#### **WARNING!**

#### **Hazard warning:**

**Incorrect installation or repair of Webasto heating systems may cause a fire or result in the emission of carbon monoxide, which can be fatal. Serious or fatal injuries can be caused as a result.**

**Specialist company training, technical documentation, specialized tools and equipment are required to install and repair Webasto heating and cooling systems.**

**NEVER attempt to install or repair Webasto heating or cooling systems if you have not successfully completed the company training and thereby acquired the required technical skills, or if you do not have access to the required technical documentation, tools and equipment needed to carry out correct installation and repairs.**

**ALWAYS follow all Webasto installation and repair instructions and observe all warnings.**

**Webasto does not accept any liability for defects and damage that are attributable to installation by untrained staff.**

## Table of Contents

Validity	2	Combustion air	7
Heater Unit/Installation Kit	3	Preparing installation location	9
Foreword	3	Installing heater unit	9
General Instructions	3	Fuel Connection	11
Special Tools	3	Coolant connection	12
Explanatory Notes on Document	4	Electrical Connections	15
Preliminary Work	5	Final Work	17
Heater unit installation location	5		
Preparing heater unit	6		

## Validity

Manufacturer	Model
Iveco	Daily

Engine type	Engine model	Output in kW	Displacement in cm <sup>3</sup>
3.0	Diesel	110	3000
3.0	Diesel	130	3000

Vehicle and engine types, equipment variants and national specifications not listed in these installation instructions have not been tested. However, installation according to these installation instructions may be possible.

The installation location of a digital timer and changeover switch should be confirmed with the end customer before installation.

**Heater Unit/Installation Kit**

Quantity	Description	Order No.:
1	Basic delivery scope of Thermo Top C Motorcaravan	9015824A
1	Installation kit of Iveco Daily 3.0 liter Diesel	9016323B

**Foreword**

The installation instructions apply to the Iveco Daily vehicles with a Diesel engine

- For the validity, see page 2 - from model year 2006 and later, assuming technical modifications to the vehicle do not affect installation, any liability claims excluded. Depending on the vehicle version and equipment, modifications may be necessary during installation with respect to these installation instructions.

However, where this is the case the stipulations in the "installation instructions" and "operating and maintenance instructions" for the *Thermo Top C Motorcaravan* should be observed.

The corresponding rules of technology and any information from the vehicle manufacturer should be observed during the installation work.

**General Instructions**

Installation should be carried out according to the general, standard rules of technology. Unless specified otherwise, fasten hoses, lines and wiring harnesses to original vehicle lines and wiring harnesses using cable ties.

Sharp edges should be fitted with edge protectors (split-open plastic hose).

Spray unfinished body areas, e.g. drilled holes, with anti-corrosion wax (Tectyl 100K, Order No. 111329).

**Special Tools**

- Torque wrench for 2.0 - 10 Nm
- Hose clamping pliers
- Riveting pliers

**Explanatory Notes on Document**

To provide you with a quick overview of the individual working steps, you will find an identification mark on the outside top right corner of the page in question.

**Mechanical system**

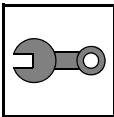

**Electrical system**

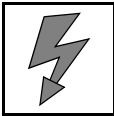

**Coolant connection**



**Fuel connection**

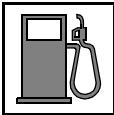

**Exhaust system**

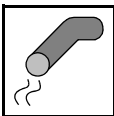

**Combustion air**

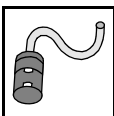

Special features are highlighted using the following symbols:



Specific risk of injury or fatal accidents.



Specific risk of damage to components.



Specific risk of fire or explosion.



Reference to general installation instructions of Webasto components or to the manufacturer's vehicle-specific documents.



Reference to a special technical feature.

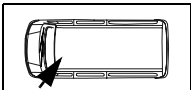
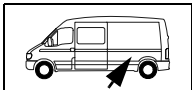

The arrow in the vehicle icon indicates the position on the vehicle and the viewing angle.

## Preliminary Work

### WARNING!

- Disconnect the battery "earth" or "ground" connection.
- Depressurize the cooling system.
- Copy the factory number from the original type label to the duplicate type label.
- Remove years that do not apply from the duplicate label.
- Attach the duplicate label (type label) in the appropriate place.
- Open the fuel tank cap, ventilate the tank.
- Close the tank cap again.
- Remove the glove compartment
- Remove the coolant expansion tank

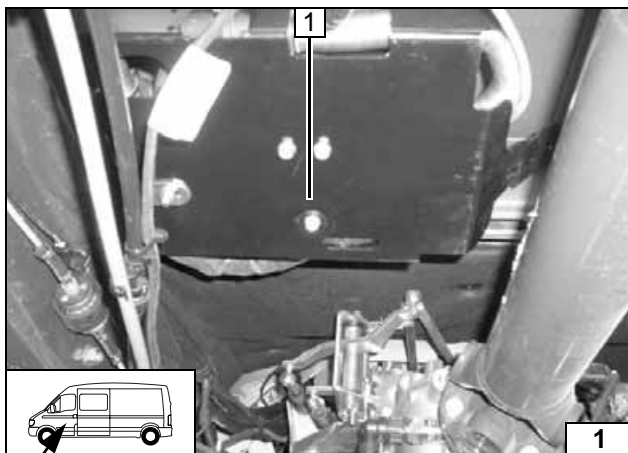

### Heater unit installation location

- 1 Heater unit

Installation  
location

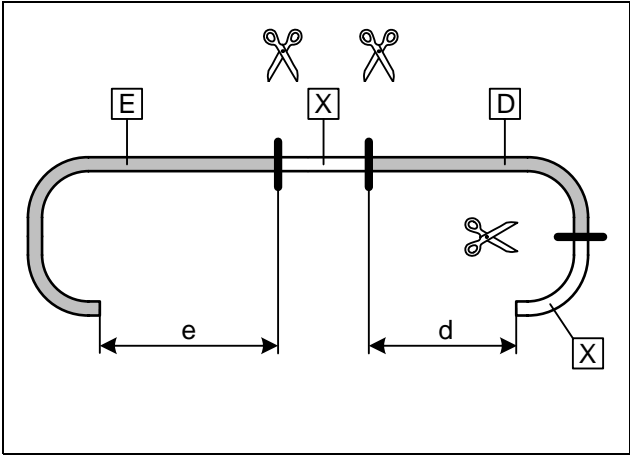

**Preparing heater unit**

e = 620 mm  
d = 520 mm

Discard section X

**Cutting 20 mm coolant hose to length**

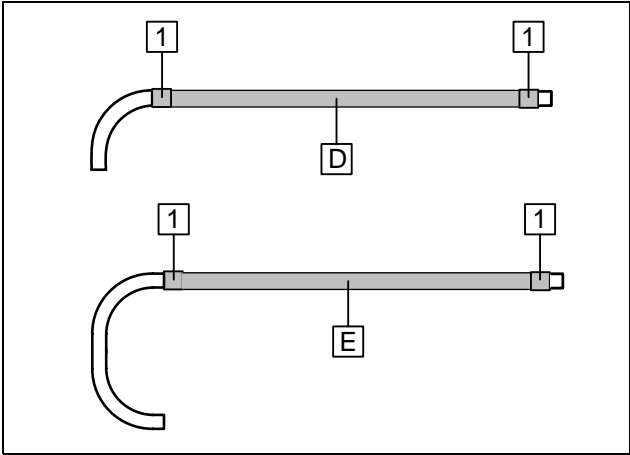

Push braided protection hose onto hose D and E and cut to length.  
Cut heat shrink plastic tubing to length.

1 25 mm heat shrink plastic tubing [4x]

**Preparing coolant hoses**

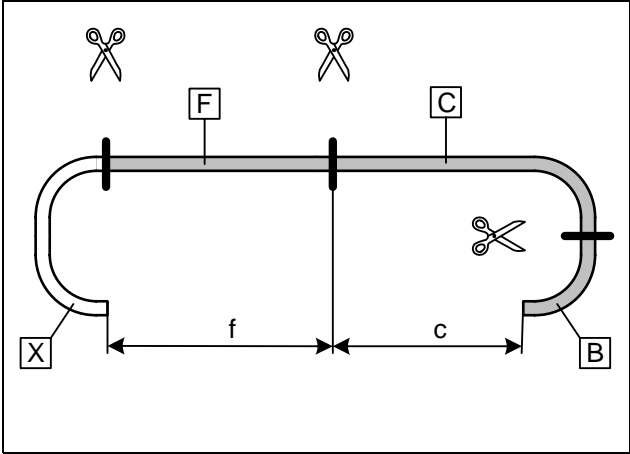

c = 1000 mm  
f = 1000 mm

Discard section X

**Cutting 20 mm coolant hose to length**

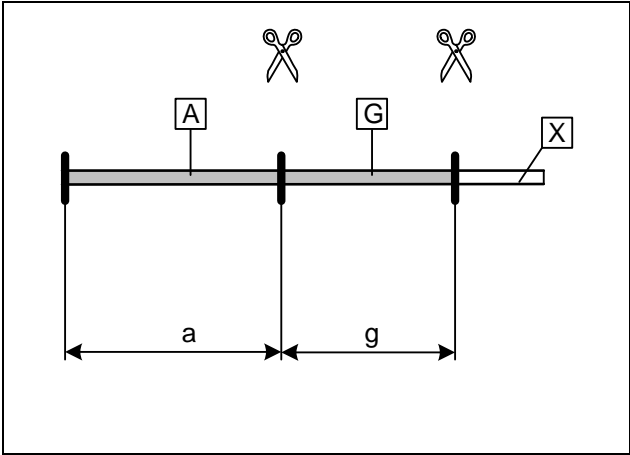

a = 420 mm  
g = 180 mm

Discard section X

**Cutting 18 mm molded hose to length**

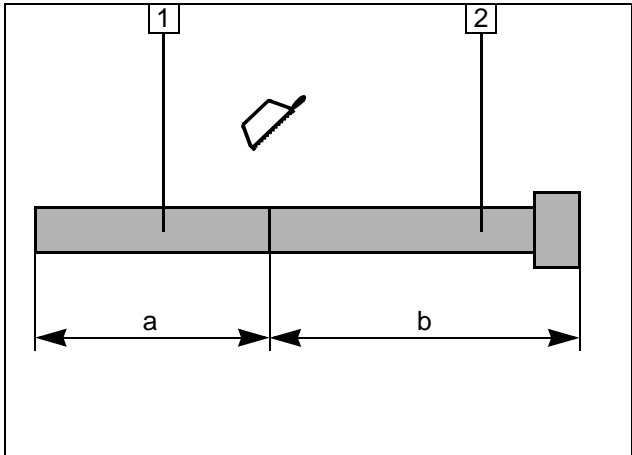

- 1 Exhaust pipe  
a = 230 mm
- 2 Exhaust end section  
b = 770 mm

Preparing exhaust pipe

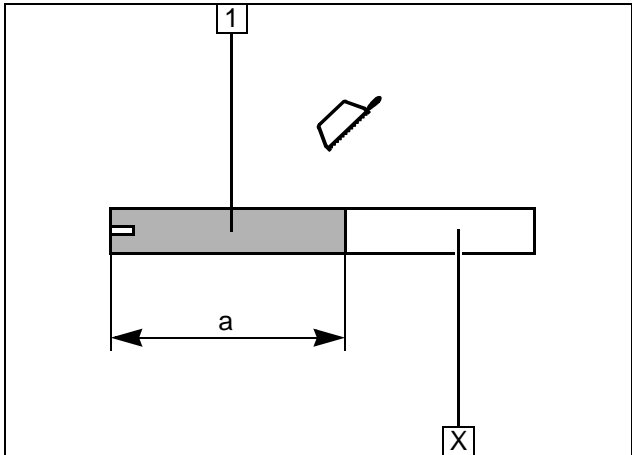

**Combustion air**

- 1 Combustion air pipe  
a = 250 mm

Discard section X

Cutting combustion air pipe to length

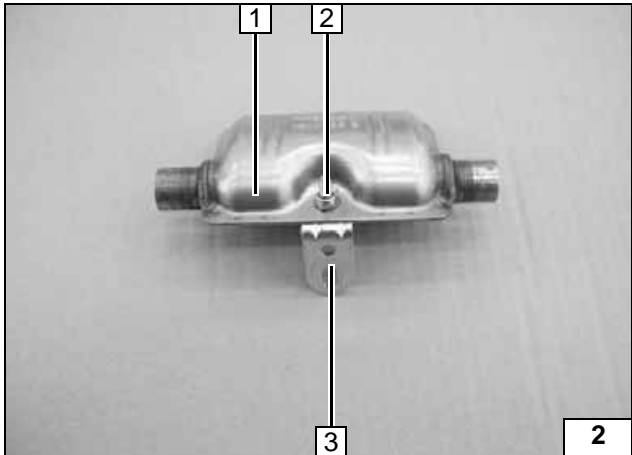

- 1 Exhaust muffler
- 2 M6x20 bolt, flanged nut
- 3 Angle bracket

Preassembling exhaust muffler

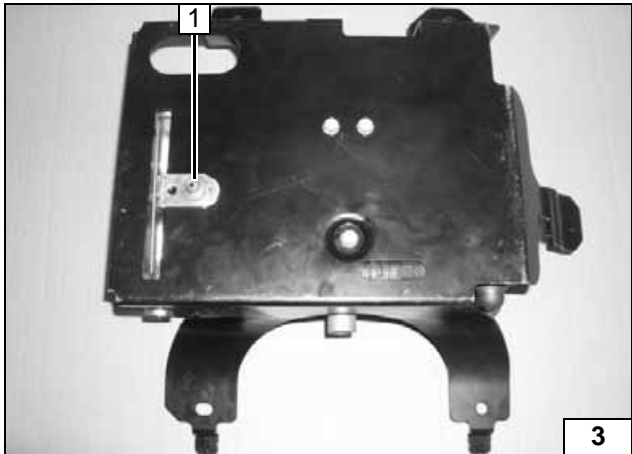

- 1 Stud bolt, large diameter washer, M6 flanged nut

Installing exhaust muffler

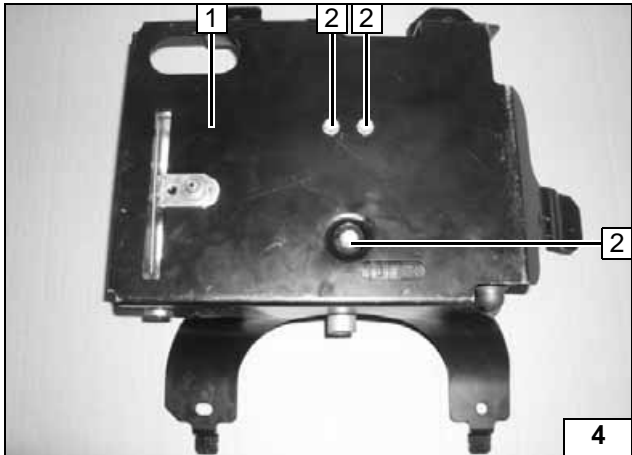

Tighten EJOT screws to 10 Nm!

- 1 Bracket
- 2 Ejot screw [3x]



Preassembling bracket on heater unit

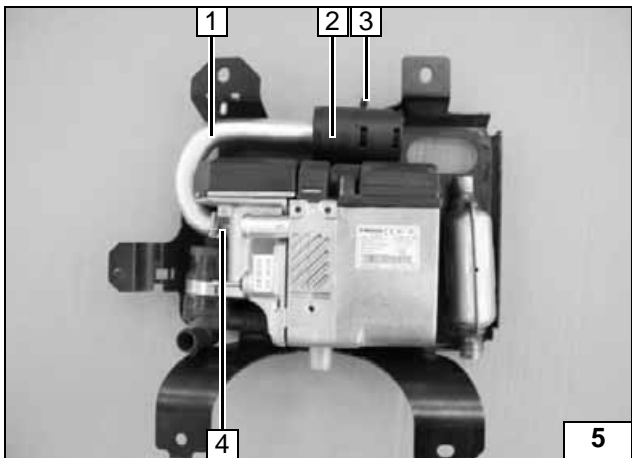

Ensure proper installation position of air intake muffler, see "Installation Instructions".

- 1 Combustion-air intake pipe
- 2 Combustion-air intake muffler
- 3 Cable tie
- 4 27 mm dia. hose clamp



Installing intake muffler

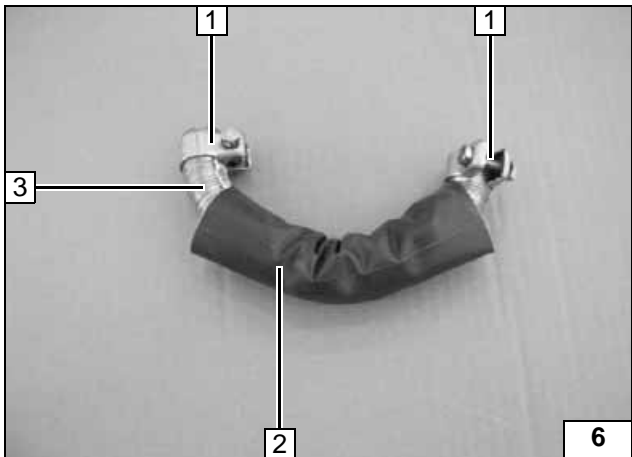

- 1 Hose clamp
- 2 Exhaust insulation, 200 mm long
- 3 Exhaust pipe

Preassembling exhaust pipe

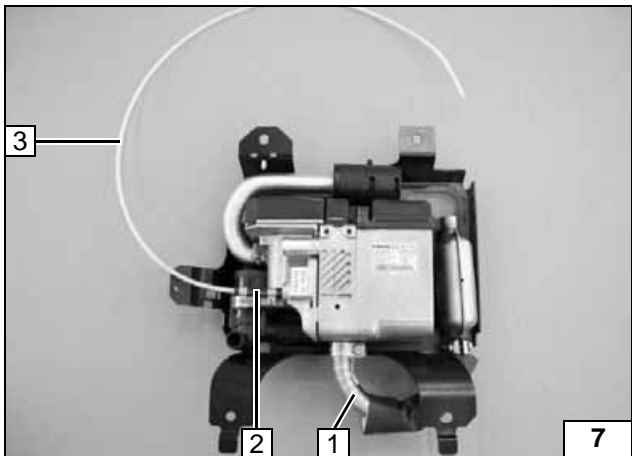

- 1 Preassembled exhaust pipe
- 2 Hose section, 10 mm dia. hose clamp [2x]
- 3 Mecanyl fuel line, 1,000 mm long

Preassembling fuel line on heater unit and installing exhaust pipe



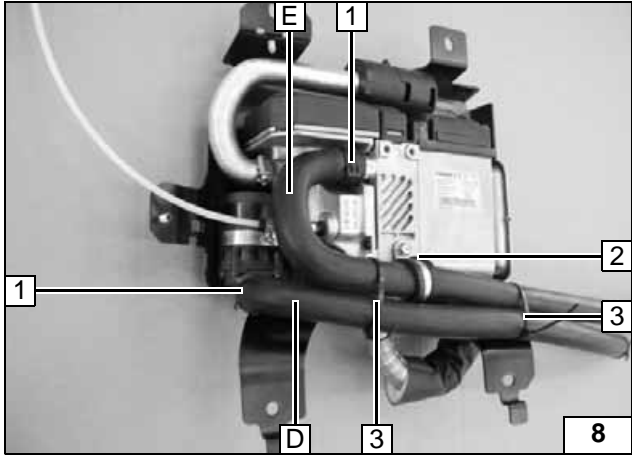
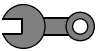

Tighten EJOT screws to 10 Nm!  
Mark hose. Shown without braided protection hose!

- 1 27 mm dia. spring clip [2x]
- 2 Eject screw, rubber-coated p-clamp
- 3 Cable tie [2x]
- D Hose on heater unit water inlet
- E Hose on heater unit water outlet



**Preassembling coolant hoses on heater unit**

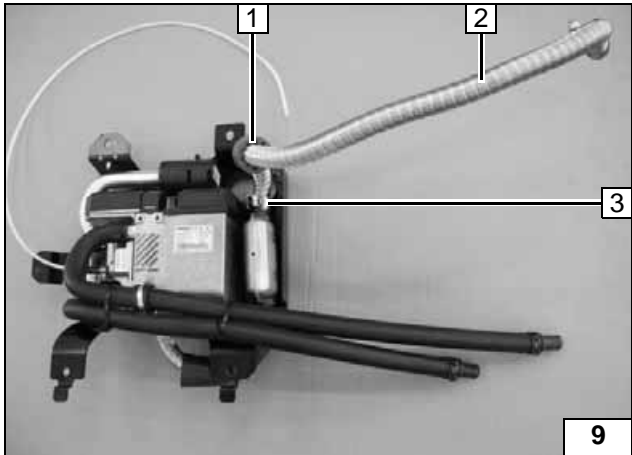

Braided protection hose not shown!

- 1 Red (rt) rubber isolator
- 2 Exhaust end section
- 3 Hose clamp

**Preassembling exhaust end section**

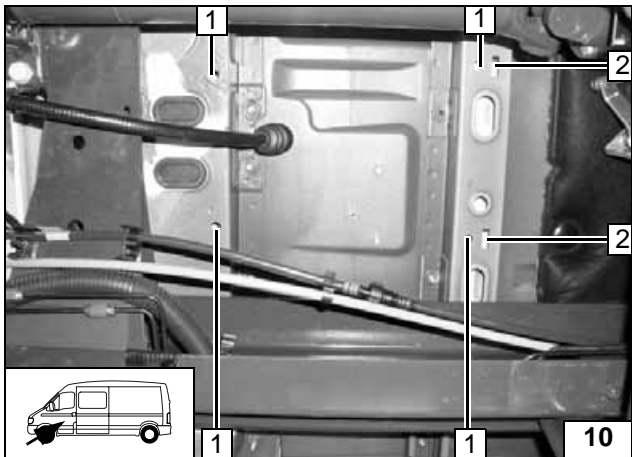

**Preparing installation location**

- 1 Insert M8 hexagon rivet nuts [4x] in existing holes
- 2 Bracket mount

**Installing rivet nut**

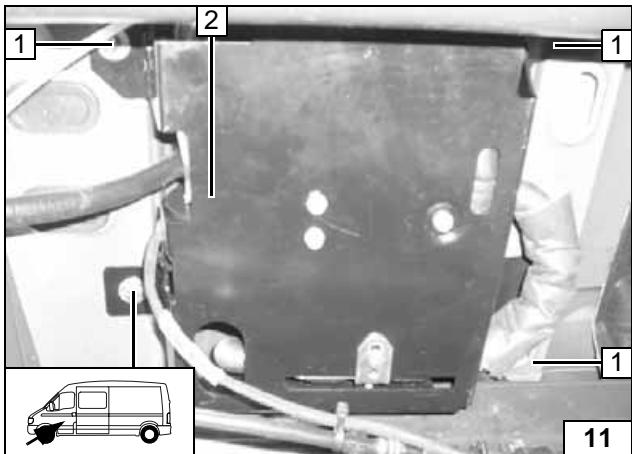

**Installing heater unit**

Mount wiring harness of heater unit before installation on heater unit, hook bracket into bracket mount with lugs and route through exhaust end section between vehicle floor and frame.

- 1 M8x30 bolt, washer, spring lockwasher [4x]
- 2 Bracket assembly with heater



**Installing heater unit**

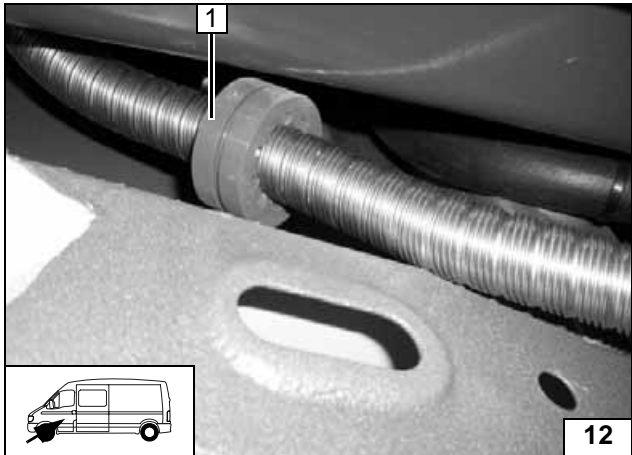

Align red (rt) rubber isolator 1

Aligning exhaust pipe

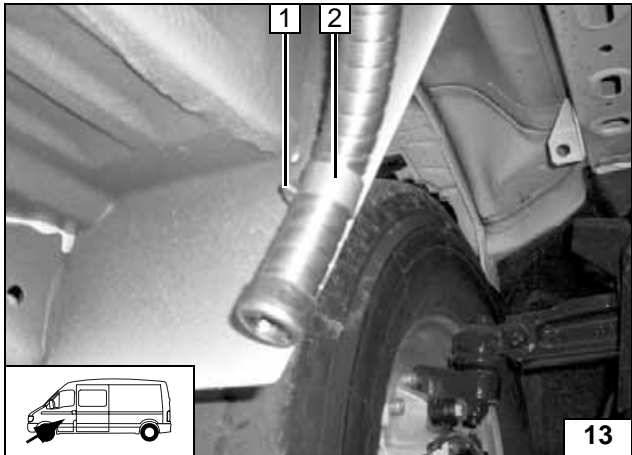

1 Original vehicle hole  
2 Pipe clamp, M6x20 bolt, flanged nut

Fastening exhaust pipe



## Fuel Connection

### CAUTION!

Open the vehicle's fuel tank cap, ventilate the tank and then re-close the tank lock.

Catch any fuel running off with an appropriate container.

Install fuel line and metering-pump wiring harness so that they are protected against stone impact. Unless specified otherwise, always fasten using cable ties.

Mount the fuel line and wiring harness with rub protection on sharp edges.

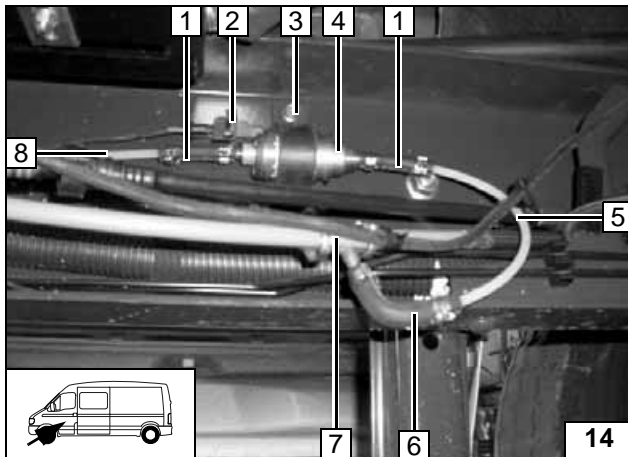

Ensure proper installation position of metering pump, see "Installation Instructions".

- 1 Hose section, 10 mm dia. hose clamp [2x]
- 2 Metering pump connector
- 3 Metering pump mounting, M6x30 bolt, flanged nut
- 4 Metering pump
- 5 Mecanyl fuel line, 250 mm long
- 6 Molded hose, 10 mm dia. Calliau clamp [2x]
- 7 8x5x8 fuel standpipe, 10 mm dia. hose clamp [2x]
- 8 Mecanyl fuel line from heater unit



**Installation location of metering pump**



Coolant connection

WARNING!

Tighten all hose clamps to 2.0 + 0.5 Nm. Any coolant running off should be collected using an appropriate container! Install hoses so that they are kink-free. Unless specified otherwise, always fasten using cable ties. Position hose clamps and spring band clamps so that no other hose can be damaged. The connection should be based on the following diagram:

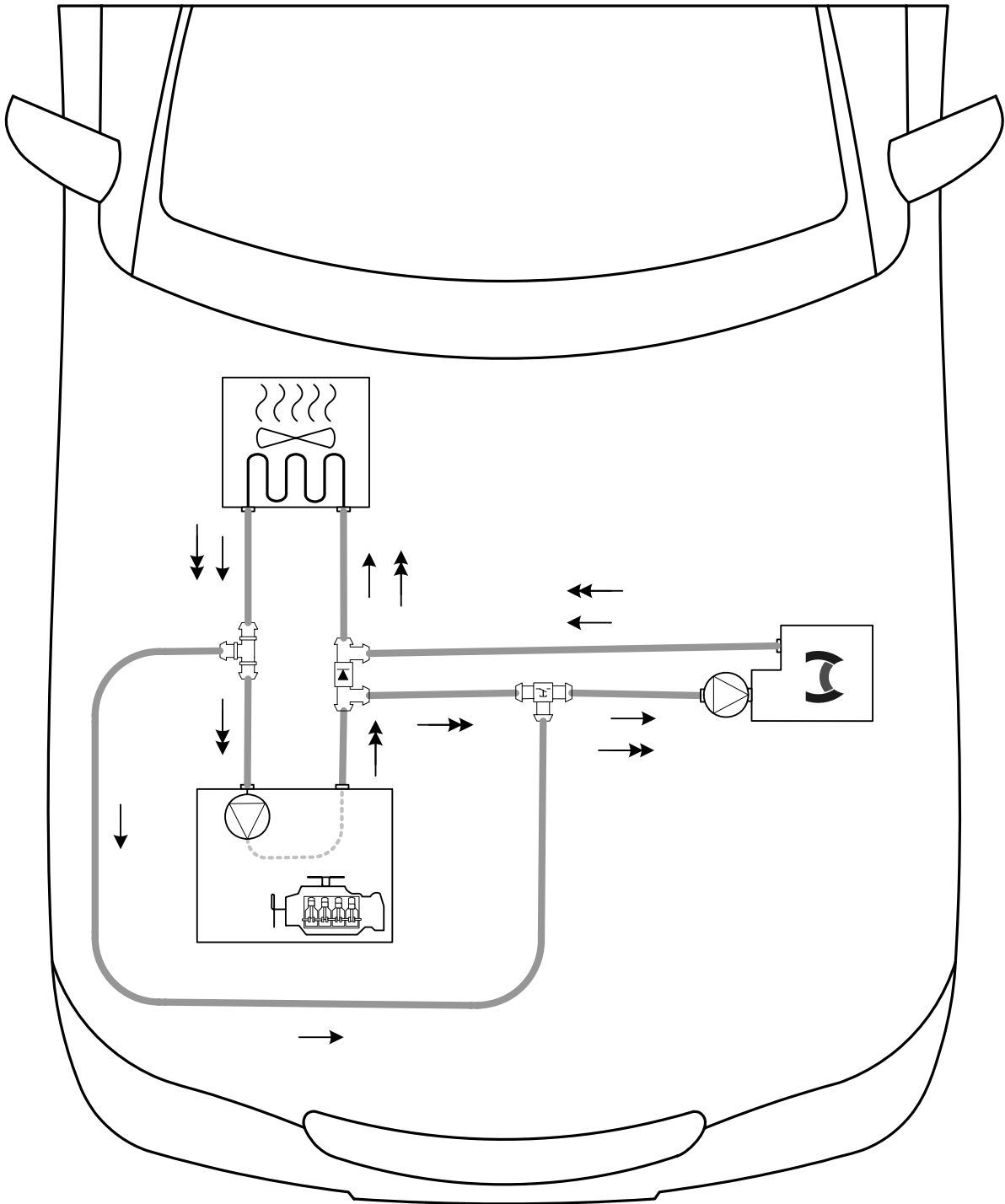

Coolant routing diagram

Coolant circuit in passenger compartment →  
Coolant circuit in passenger compartment and engine →→



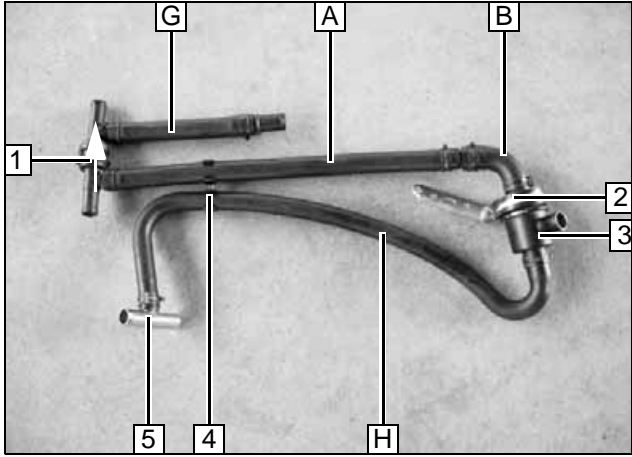

- 1 Check valve (watch direction of flow)
- 2 Rubber-coated p-clamp, perforated bracket, M6x20 hexagon bolt, flanged nut
- 3 Thermostat valve
- 4 Spacer bracket
- 5 T-piece, 18x15x18

Preparing hose group

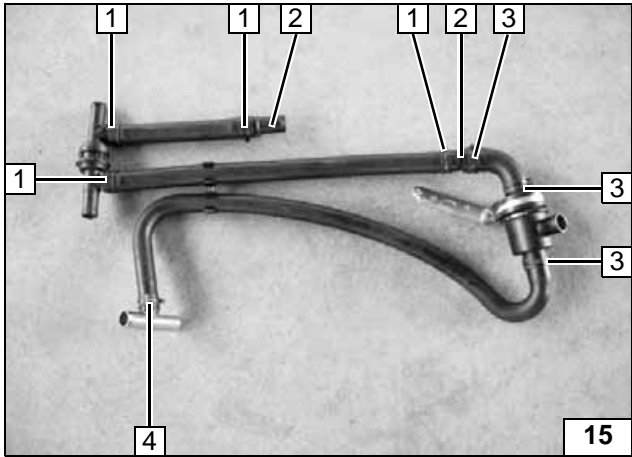

- 1 Spring clip 25 [4x]
- 2 Connecting pipe 18/20 [2x]
- 3 Spring clip 27 [3x]
- 4 Spring clip 22

Preparing hose group

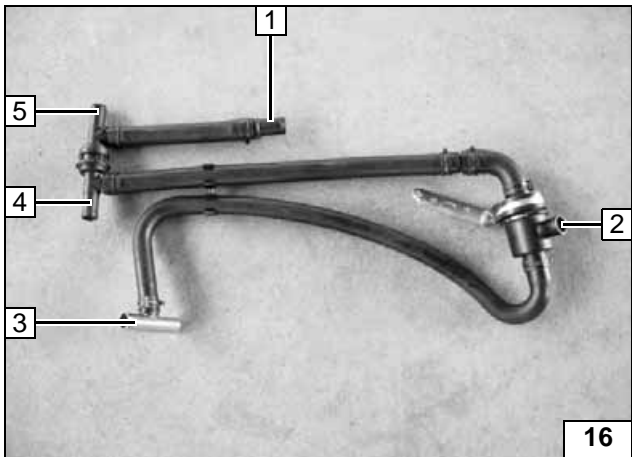

- 1 Heater unit outlet (F,E)
- 2 Heater unit inlet (C,D)
- 3 Original vehicle return line
- 4 From engine outlet
- 5 To heat exchanger inlet

Connections

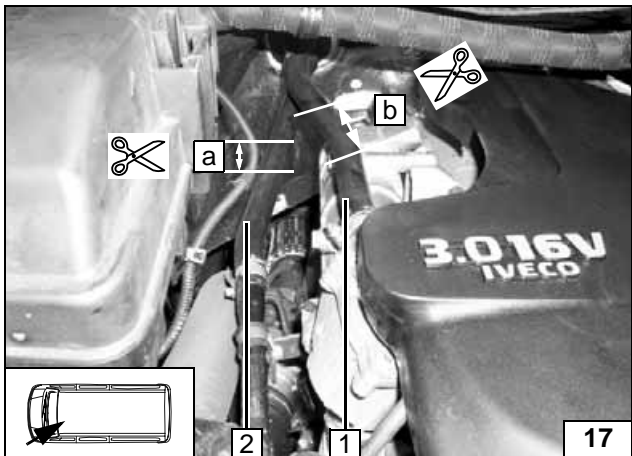

- 1 Original vehicle hose from engine outlet to heat exchanger inlet
- 2 Original vehicle return hose

a = 15 mm  
b = 100 mm

Discard hose sections

Cutting points

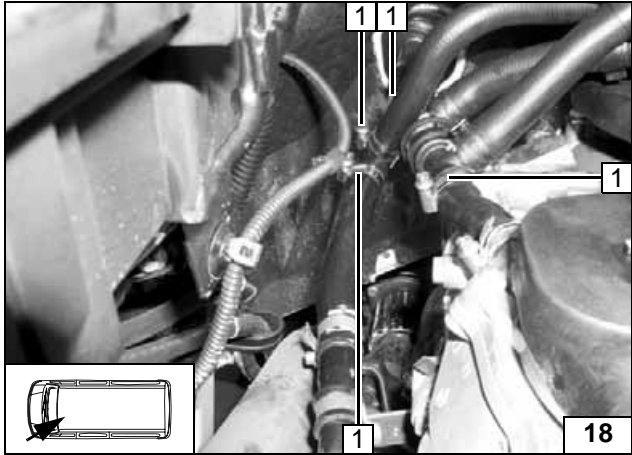

1 Hose clamp 20...27 [4x]

Con-  
nection on  
vehicle  
side

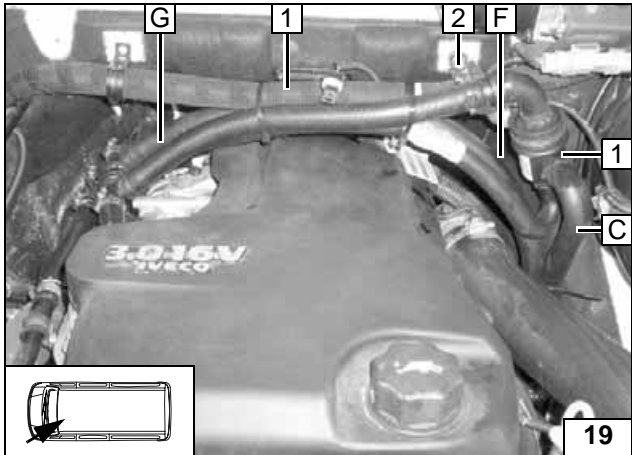

1 Spring clip 27 [2x]  
2 Original vehicle bolt

Connect hose **F** to hose **G**  
Connect hose **C** to thermostat valve  
Push black (sw) rubber isolator onto hose **C**

Routing in  
engine  
compartment

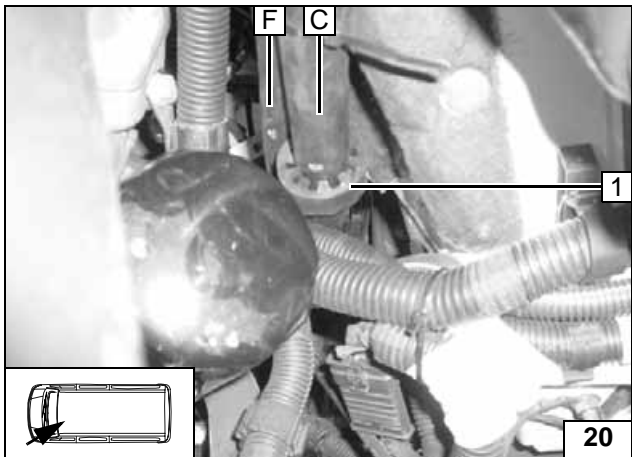

Mark hoses **C** and **F** and route downward



1 Position black (sw) rubber isolator

Con-  
nection to  
engine  
outlet

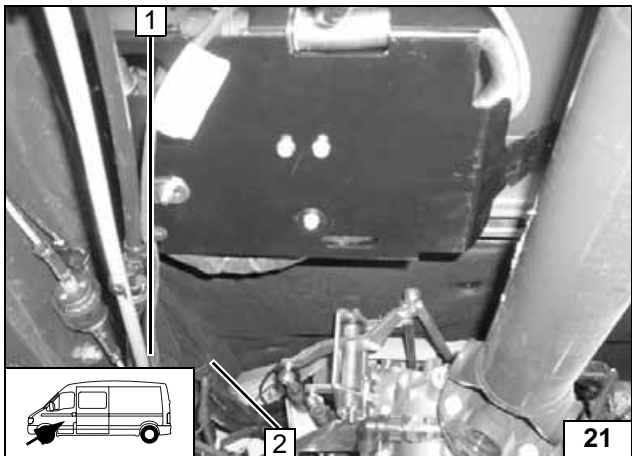

Secure hoses and wiring harness of metering pump with cable ties while watching distance to steering spindle.



1 Spring clip 27, hose C and D  
2 Spring clip 27, hose E and F

Con-  
nection on  
heater unit



## Electrical Connections

### Wiring harness pass through

- 1 Protective rubber plug

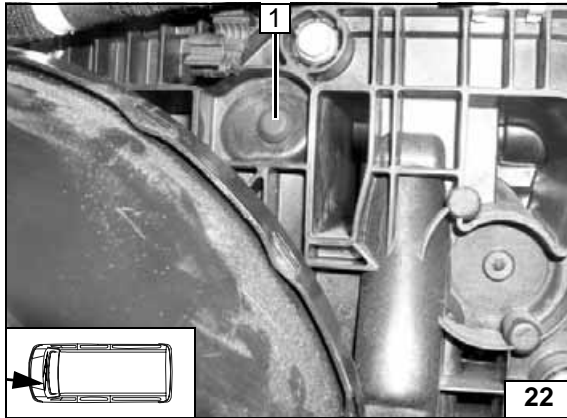

### Digital timer

- 1 Changeover switch
- 2 Digital timer

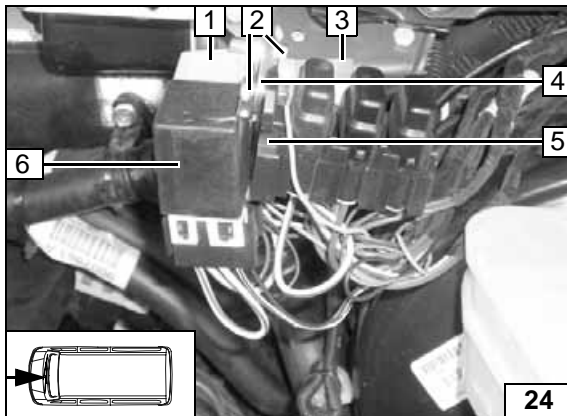
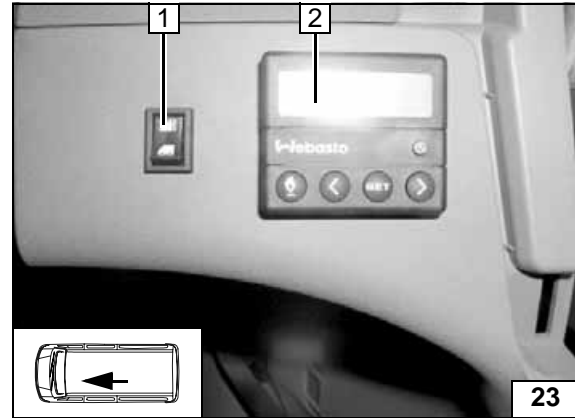

### Preassembling fuse holder

- 1 K3 relay
- 2 M5x16 bolt, washers, M5 nut [2x]
- 3 K4 relay
- 4 Perforated plate angled downward
- 5 Fuse holder
- 6 K5 relay

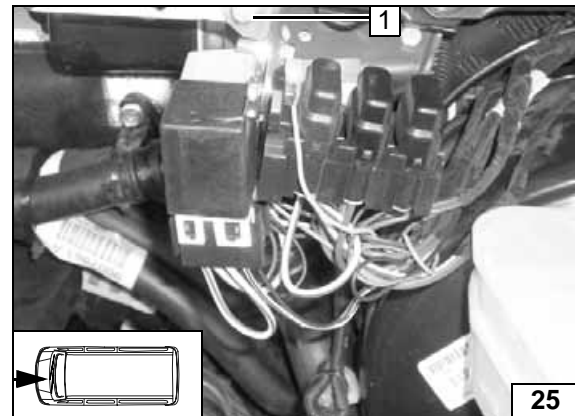

### Installing fuse holder

- 1 M6x20 bolt, washer, flanged nut



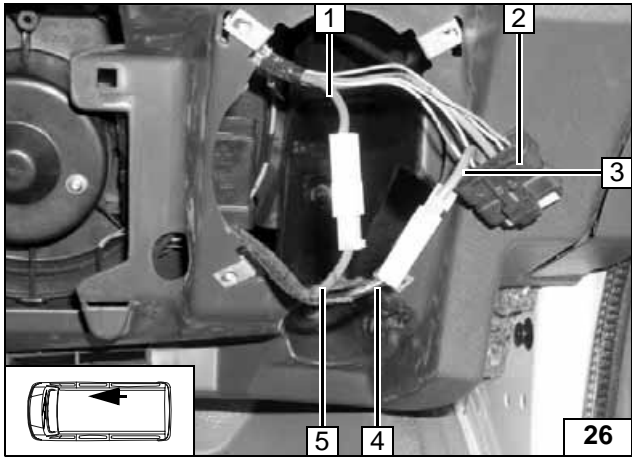

Connection to 6-pin connector **2** from fan motor.  
Make connections as shown in the wiring diagram with the tab receptacles provided.

- 1 Red (rt) wire from fan motor
- 3 Red (rt) wire to connector, to fuse
- 4 Red (rt) wire from K3/87a
- 5 Black (sw) wire from K3/30



Connecting fan motor

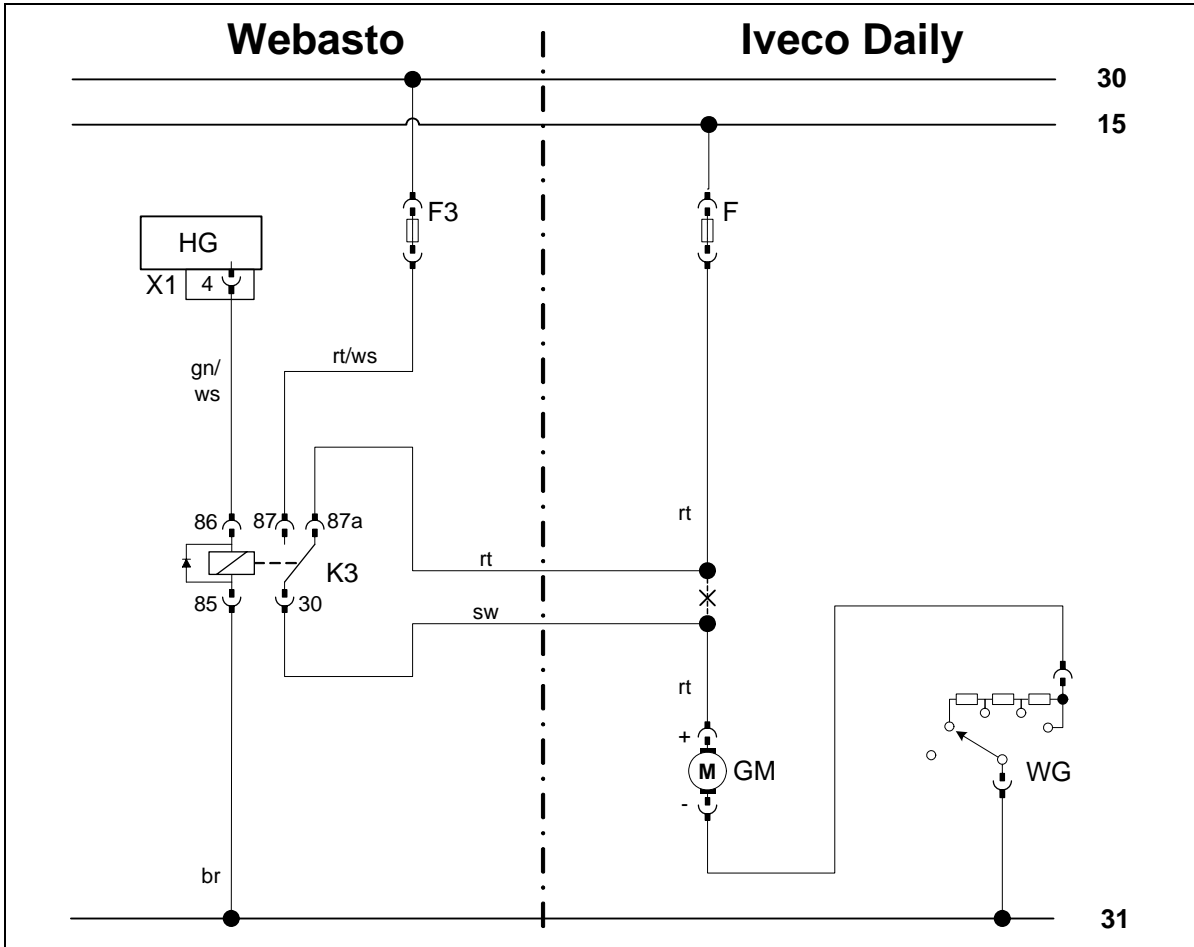

Wiring diagram for manual air conditioning

Webasto components		Components of Iveco Daily		Colors and symbols	
HG	Heater unit TT-C/E	GM	Fan motor	rt	red
X1	6-pin connector	WG	Resistor group	ws	white
F3	Fuse, 25 A	F	Fan fuse	sw	black
K3	Fan relay			br	brown
				gn	green
				X	Cutting point
				Wiring colors may vary.	

Legend



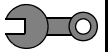

## Final Work

### WARNING!

Reassemble the disassembled components in reverse order.

Check all hoses, hose, spring and Caillau clamps, as well as all electrical connections for firm seating.

Secure all loose cables using cable ties.

Only use manufacturer-approved coolant.

Spray the heater unit components with anti-corrosion wax (Tectyl 100K, Order No. 111329).

- Connect the battery
- Start the engine, bleed the coolant circuit according to the vehicle manufacturer's instructions and top up coolant
- Set the digital timer.
- Check the proper operation of the additional heater, see the operating instructions/installation instructions.
- Attach the "Switch off additional heater before refueling" sticker to the left-hand B-pillar.



# Webasto

*Feel the drive*

Webasto AG  
Postfach 80 - 82132 Stockdorf, Germany - Hotline +49-  
(0)1805-932278  
Hotfax +49-(0)395-5592-353 - <http://www.webasto.de>