

Water Heater Unit



Thermo Top V Additional Heater ^{e1} 00 0018

Installation Instructions

Mercedes Benz C Class S204, W204 / from Model Year 2007
GLK-Class X204 / from Model Year 2008

Gasoline

Left-hand drive vehicle

AMG 950 Sports Package

Not on C 63 AMG



WARNING!

Hazard warning:

Incorrect installation or repair of Webasto heating systems may cause a fire or result in the emission of carbon monoxide, which can be fatal. Serious or fatal injuries can be caused as a result.

Specialist company training, technical documentation, specialized tools and equipment are required to install and repair Webasto heating and cooling systems.

NEVER attempt to install or repair Webasto heating or cooling systems if you have not successfully completed the company training and thereby acquired the required technical skills, or if you do not have access to the required technical documentation, tools and equipment needed to carry out correct installation and repairs.

ALWAYS follow all Webasto installation and repair instructions and observe all warnings.

Webasto does not accept any liability for defects and damage that are attributable to installation by untrained staff.

Mercedes Benz C Class S204, W204 / GLK Class X204

Table of Contents

Validity	2	Exhaust gas	17
Heater Unit/Installation Kit	3	Fuel	18
Foreword	3	Coolant connection	25
General Instructions	3	C180 K, C200 K without electr. circulating pump	25
Special Tools	3	C230, C280, C350, GLK280, GLK350	
Explanatory Notes on Document	4	with electr. circulating pump	28
Preliminary Work	5	Combustion air	31
Heater unit installation location	5	Vehicle without electr. circulating pump	31
Preparing electrical system	6	Vehicle with electr. circulating pump	31
Electrical system	7	Aligning exhaust end section	32
Automatic air-conditioning fan controller	9	Final Work	33
Heater controls	11		
Telestart	13		
Preparing heater unit	14		
Preparing installation location	14		
Installing heater unit	16		

Validity

Manufacturer	Model	Type	EG-BE No./ABE
Daimler AG	C Class	W204	e1 * 2001/116 * 0431 * ...
Daimler AG	C Class	S204	e1 * 2001/116 * 0431 * ...
Daimler AG	GLK Class	X204	e1 * 2001/116 * 0480 * ...

W 204 Sedan, S 204 Station Wagon

Type	Engine model	Output in kW	Displacement in cm ³
C 180 K	Gasoline	115	1796
C 200 K	Gasoline	135	1796
C230	Gasoline	150	2496
C280	Gasoline	170	2996
C 280 4Matic	Gasoline	170	2996
C350	Gasoline	200	3498
C 350 4Matic	Gasoline	200	3498

X 204 GLK

Type	Engine model	Output in kW	Displacement in cm ³
GLK 280 4Matic	Gasoline	170	2996
GLK 350 4Matic	Gasoline	200	3498

Vehicle and engine types, equipment variants and national specifications not listed in these installation instructions have not been tested. However, installation according to these installation instructions may be possible.

Mercedes Benz C Class S204, W204 / GLK Class X204

Heater Unit/Installation Kit

Quantity	Description	Order No.:
1	LU TT-V Mercedes Benz C Class S204, W204 / W204 / GLK Class X204 Gasoline with Telestart T91	1312851B

Optional heater control either:

Quantity	Description	Order No.:
1	Digital timer 1533 only in conjunction with mit Y-adapter	9005753C 9001505A
1	Thermo Call Comfort/Connect/Locate	See price list

The installation location of the digital timer/push button should be confirmed with the end customer before installation.



Foreword

These installation instructions apply to Mercedes Benz C Class S204, W204 / GLK Class X204 vehicles with a Gasoline engine - for validity, see page 2 - from model year 2007 and later, and GLK Class X204 vehicles from model year 2008, assuming technical modifications to the vehicle do not affect installation, any liability claims excluded. Depending on the vehicle version and equipment, modifications may be necessary during installation with respect to these installation instructions.

However, where this is the case the stipulations in the "installation instructions" and "operating and maintenance instructions" for the *Thermo Top V* should be observed.

The corresponding rules of technology and any information from the vehicle manufacturer should be observed during the installation work.

The additional ventilation function is not possible!

General Instructions

Installation should be carried out according to the general, standard rules of technology. Unless specified otherwise, fasten hoses, lines and wiring harnesses to original vehicle lines and wiring harnesses using cable ties.

Sharp edges should be fitted with edge protectors (split-open plastic hose).

Spray unfinished body areas, e.g. drilled holes, with anti-corrosion wax (Tectyl 100K, Order No. 111329).

Special Tools

- Torque wrench for 2.0 - 10 Nm
- Hose clamping pliers
- Metric thread-setter kit

Explanatory Notes on Document

To provide you with a quick overview of the individual working steps, you will find an identification mark on the outside top right corner of the page in question.

Mechanical system

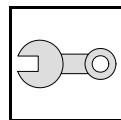

Electrical system

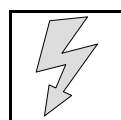

Coolant

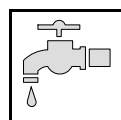

Fuel

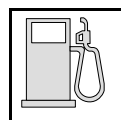

Exhaust gas

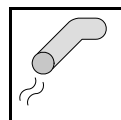

Combustion air

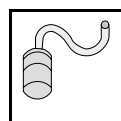

Special features are highlighted using the following symbols:



Specific risk of injury or fatal accidents.



Specific risk of damage to components.



Specific risk of fire or explosion.



Reference to general installation instructions of Webasto components or to the manufacturer's vehicle-specific documents.



Reference to a special technical feature.



The arrow in the vehicle icon indicates the position on the vehicle and the viewing angle.

All dimensions are in mm!

Tightening torque of hose clamps = 2.0 + 0.5 Nm!

Tightening torque of Ejet screws, Ejet studs = 10 Nm!

Preliminary Work

WARNING!

- Open fuel tank cap, ventilate tank.
- Close the tank cap again.
- Depressurize the cooling system!
- Copy the factory number from the original type label to the duplicate type label.
- Remove years that do not apply from the duplicate label.
- Attach the duplicate label (type label) in the appropriate place.
- Remove the windshield wipers.
- Remove the coolant reservoir cap.
- Remove the dome strut on the left.
- Remove entire windshield wiper linkage with engine.
- Remove the battery cover in the engine compartment on the right.
- Open the cover of the central electrical box on the left in the engine compartment.
- Detach the central electrical box.
- Detach the coolant expansion tank.
- Take off the cover off the positive distributor in the engine compartment.
- Remove the air intake pipe on the right (V6 only).
- Remove the lower engine cover.
- Remove the lower right vehicle trim.
- Remove the right-hand wheel.
- Remove the right-hand wheel well trim.
- Remove the seat bench of the rear bench seat.
- Open the right-hand fuel sender service lid.
- Detach the fuel-tank sending unit on the right as described in the manufacturer's instructions.
- Remove the A/C control panel.
- Lift the shift lever cover.
- Remove the ashtray or storage compartment with the socket outlet below the A/C control panel.
- Remove the accelerator pedal.
- Remove the A-pillar trim in the footwell on the left.
- Remove the front left door sill cover.
- Remove the lower left instrument panel trim.
- Remove the front left floor trim.

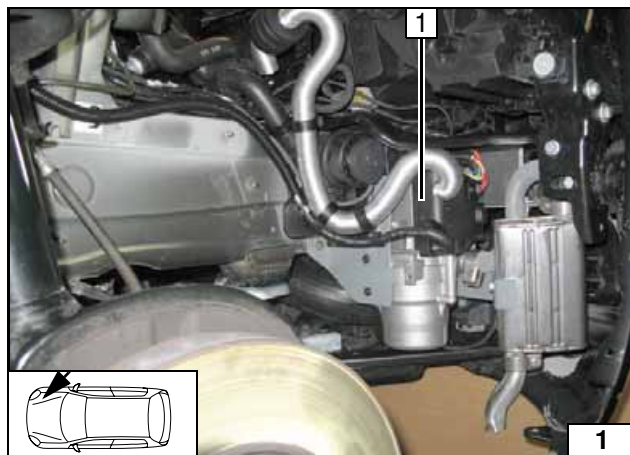

Heater unit installation location

1 Heater unit

Installation location

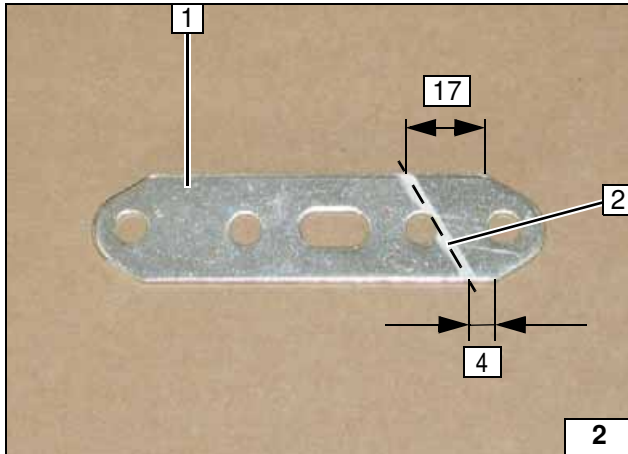

Preparing electrical system

Angle down perforated bracket 1 on bending edge 2 by 95°.



Bending perforated bracket

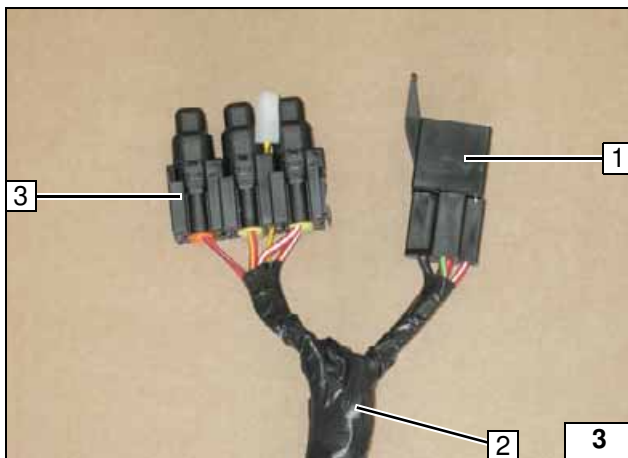

Wrap wiring harness of heater unit 2 with insulating tape.

- 1 K3 relay
- 3 Fuse holder



Wrapping wiring harness



Electrical system

Fuse holder, K3 relay

- 1 M5x16 bolt, washers, retaining plate of fuse holder, K3 relay, M5 nut
- 2 Original vehicle nut, ground support point
- 3 Ground cable of heater unit, 6 mm dia. cable lug
- 4 Perforated bracket
- 5 Fuse holder

Connection to positive support point

- 1 Positive support point (only use this!)
- 2 Positive cable of wiring harness for heater unit, crimp on 8 mm dia. cable lug

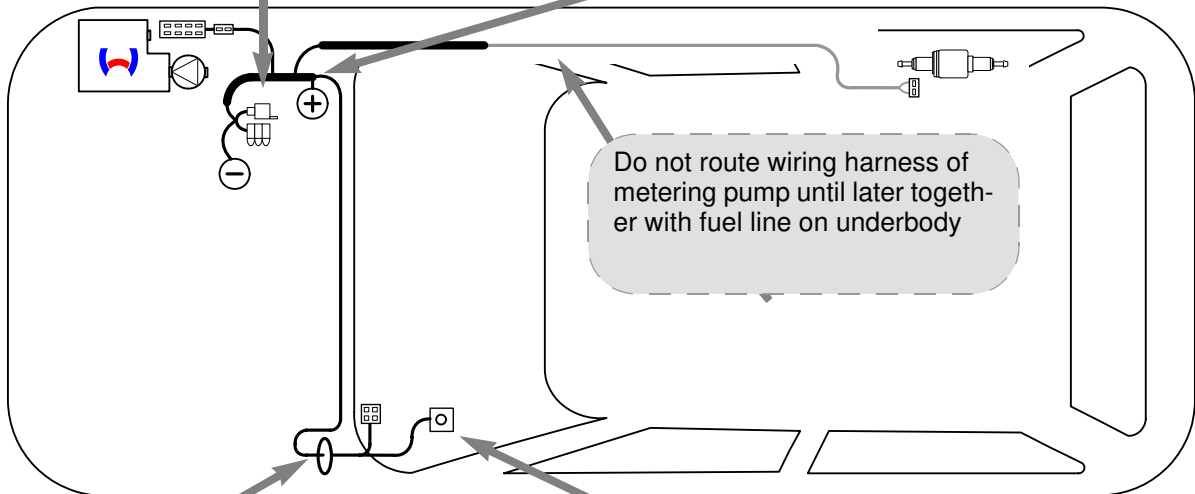
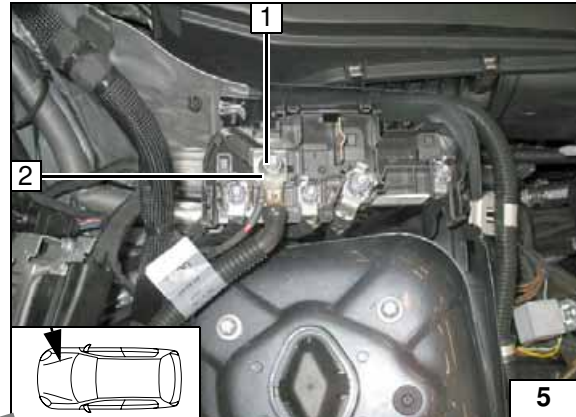
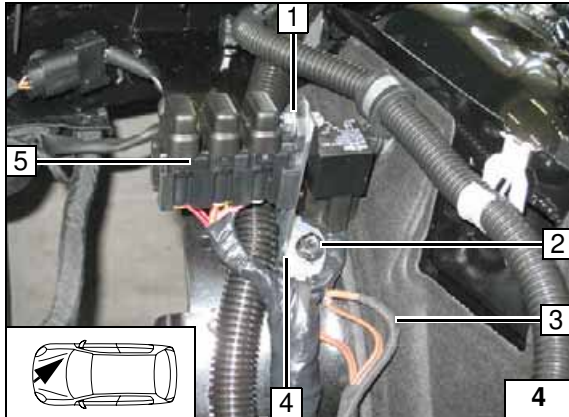

Wiring harness installation diagram

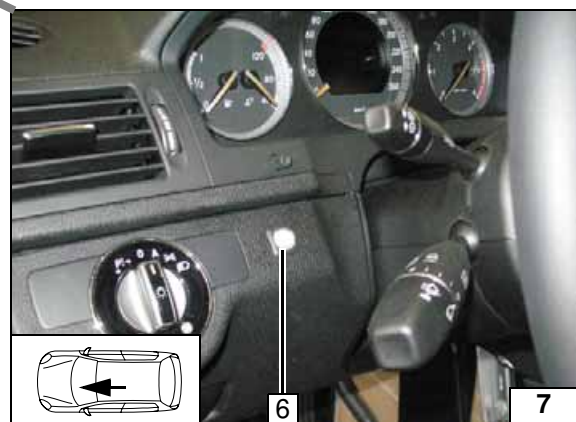
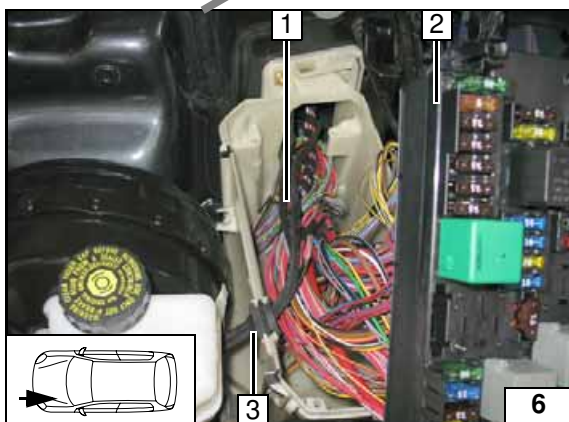

Wiring harness pass through

- 1 Wiring harness of heater control, wiring harness of fan controller relay K3
- 2 Central electrical box
- 3 Cable grommet

Push button

- 1 Push button, 16 mm dia. hole

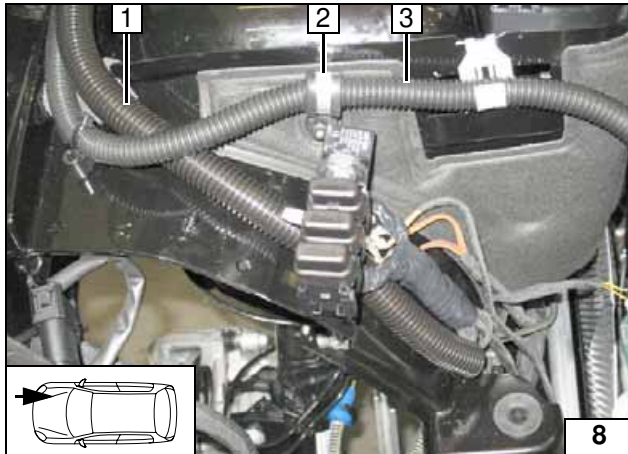

Fasten original vehicle wiring harness **3** with 15 mm dia. p-clamp **2** on stud bolt with plastic nut.

1 Wiring harness of heater control, wiring harness of fan controller and cable of positive supply in 17 mm dia. corrugated tube



Installing wiring harnesses

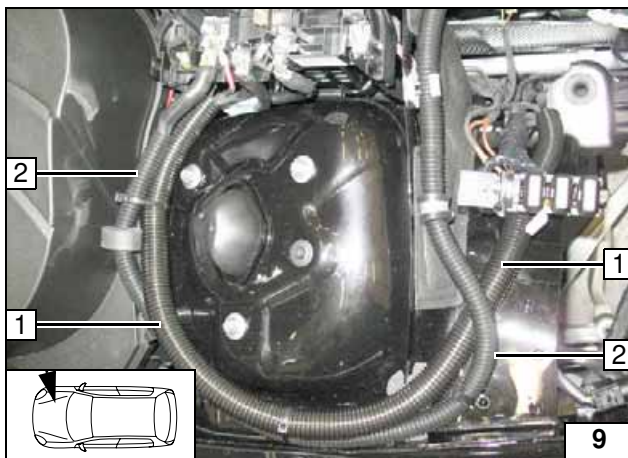

Fasten 17 mm dia. corrugated tube **1** with cable tie.

2 Original vehicle wiring harness



Cable routing in engine compartment

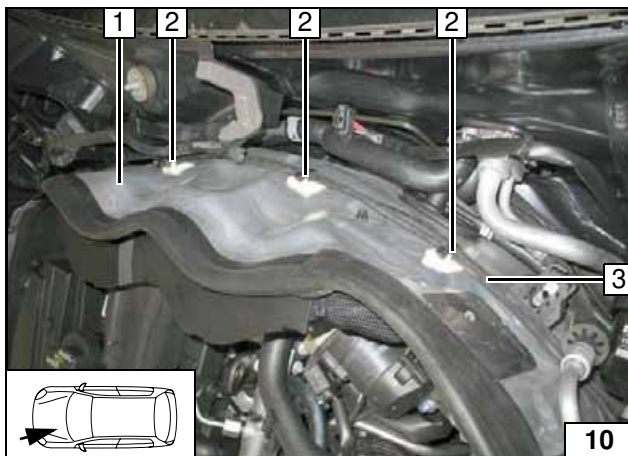

Glue adhesive base **2** [3x] to partition wall **1** and secure wiring harness of heater control and wiring harness of fan controller **3** with cable ties [3x]!



Cable routing in engine compartment

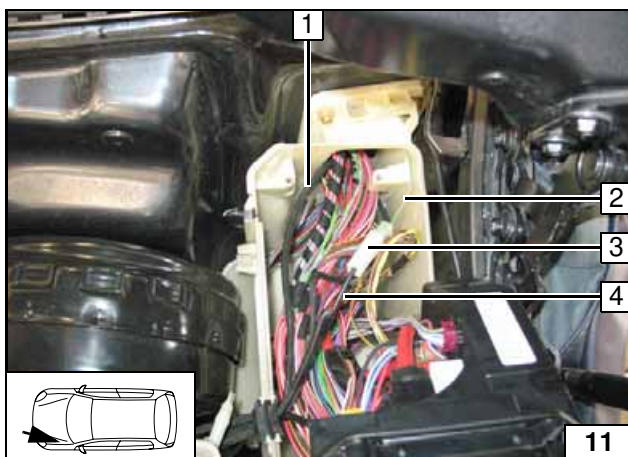

Connect green/white (gn/ws) wire **2** with connectors **3** to black (sw) wire **4**, insulate red (rt) wire and tie back.

1 Wiring harness of heater control



Extending black (sw) wire



Automatic air-conditioning fan controller

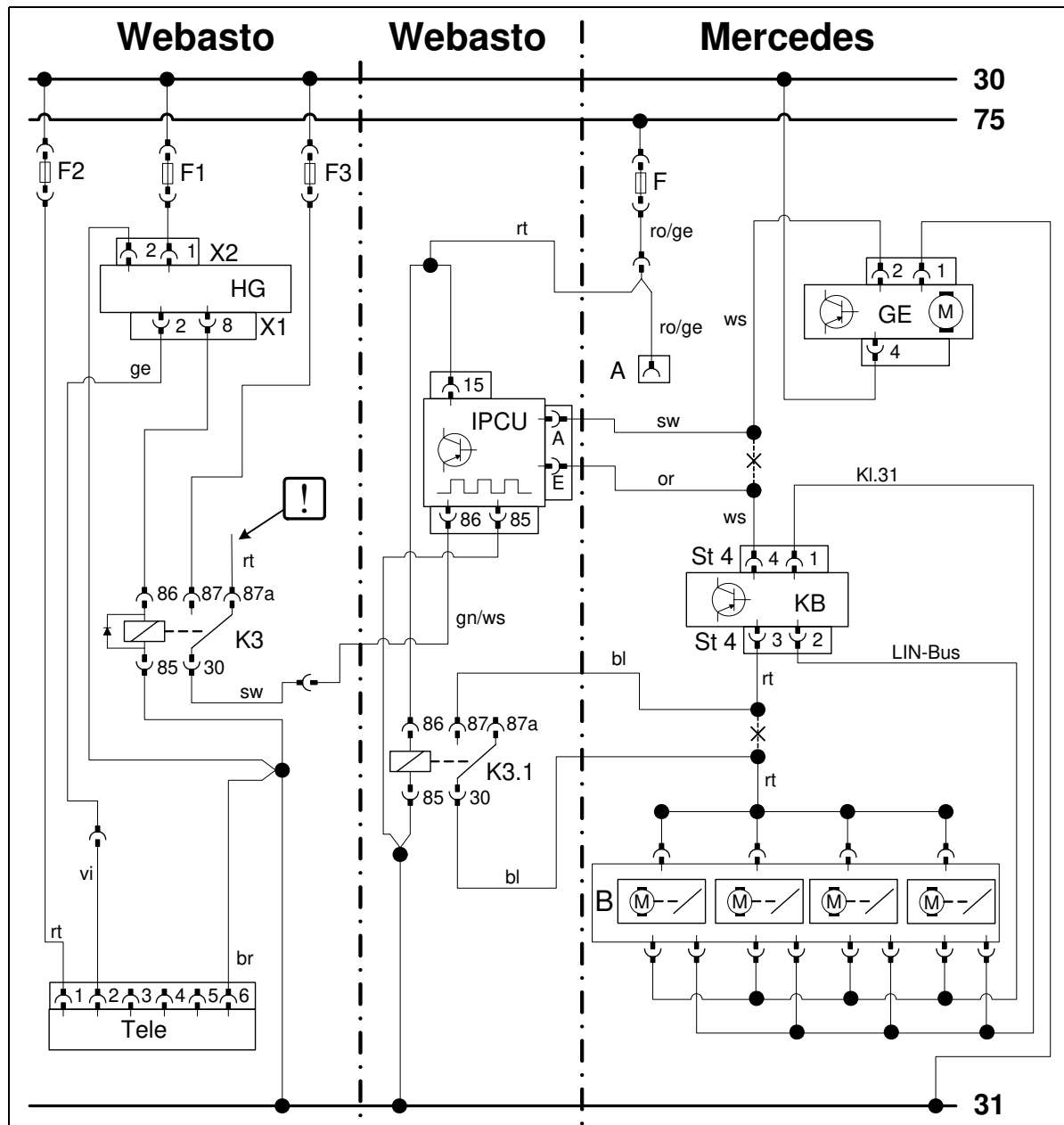

Wiring diagram

Webasto components		Vehicle components		Colors and symbols	
HG	TT-V heater unit	ge	Fan unit	rt	red
X1; X2	Connector HG	KB	Air-conditioning control panel	ws	white
F1	Fuse, 20 A	a	Socket outlet/lighter	sw	black
F2	1 A fuse	b	Flap positioning module	bl	blue
F3	Fuse 5A	F	Fuse	ro	pink
K3	Relay	ST 4	Connector, 4-pin, KB	ge	yellow
K3.1	Relay			or	orange
IPCU	Pulse width modulator			vi	violet
Tele	Telestart				
IPCU adjustment values:					
Duty cycle:31 %				Insulate wire ends and tie back	
Frequency:300 Hz					
Voltage:7.4 V					
Function:Low-side					
				X Cutting point	
				Wiring colors may vary.	

Legend

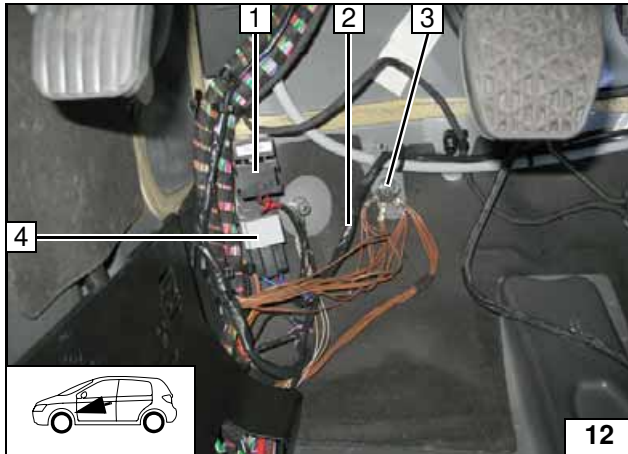

Route additional wiring harness of fan controller **2** to center console, connect according to wiring diagram and secure with cable ties.

- 1** IPCU, adhesive tape
- 3** Ground point
- 4** Relay K3.1, adhesive tape



Connecting and routing wiring harness

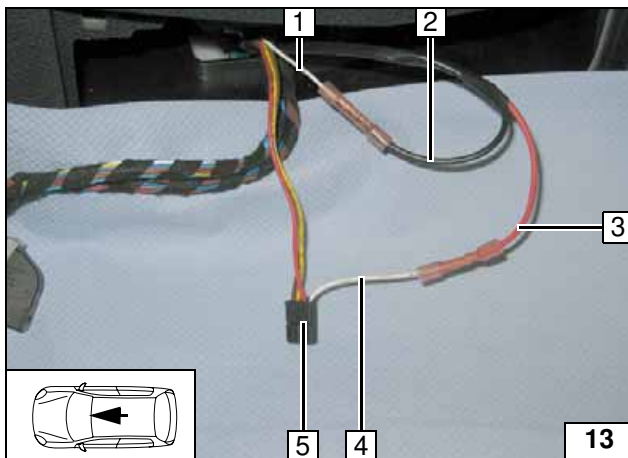

Connection to 4-pin connector **5** from A/C control element.
Produce connections as shown in wiring diagram.

- 1** White (ws) wire
- 2** Black (sw) wire of IPCU/A
- 3** Orange (or) wire of IPCU/E
- 4** White (ws) wire of connector



Connecting A/C control panel

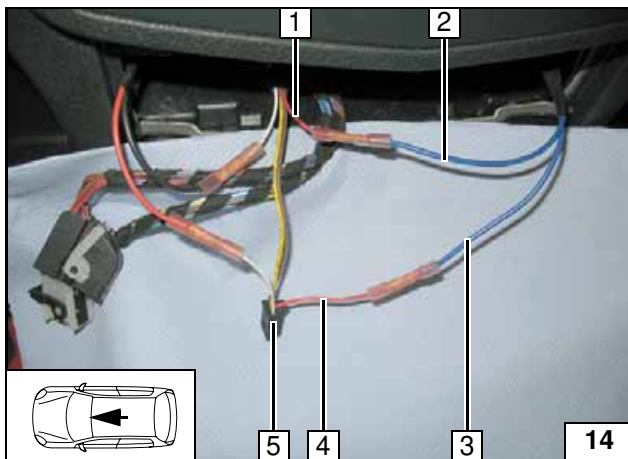

Connection to 4-pin connector **5** from A/C control element.
Produce connections as shown in wiring diagram.

- 1** Red (rt) wire
- 2** Blue (bl) wire K3.1
- 3** Blue (bl) wire K3.1
- 4** Red (rt) wire of connector



Connecting A/C control panel

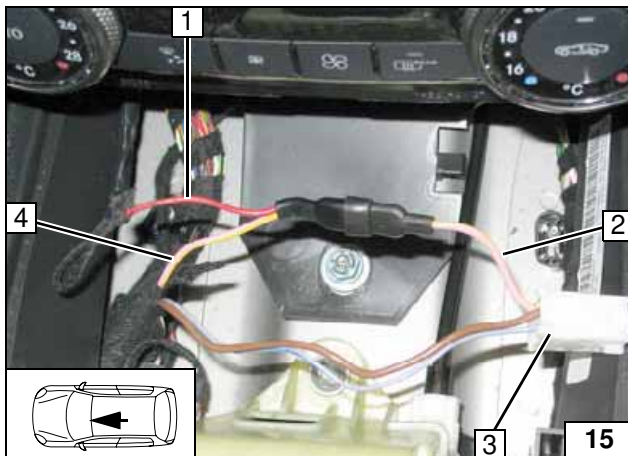

Connection to plug-in connector **3** of socket outlet/lighter.
Produce connections as shown in wiring diagram.

- 1** Red (rt) wire K3.1/86, IPCU/15
- 2** Pink/yellow (ro/ge) wire
- 4** Pink/yellow (ro/ge) wire



Connection to socket outlet/lighter



Heater controls

Telestart and push button combination

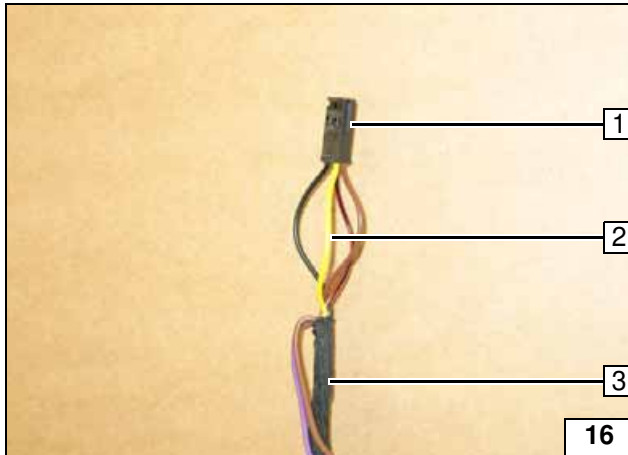

Mount yellow (ge) wire 2 in free socket of 4-pin connector 1 of heater-unit wiring harness 3.



Preparing wiring harness of heater unit

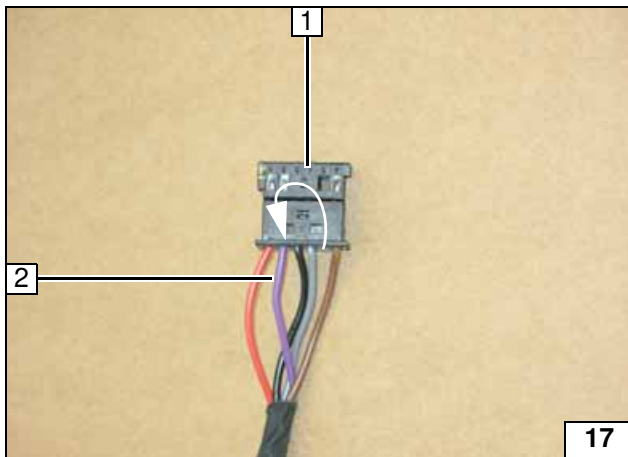

Move violet (vi) wire 2 from socket 5 to socket 2 in 6-pin connector of Telestart 1.



Preparing Telestart connector

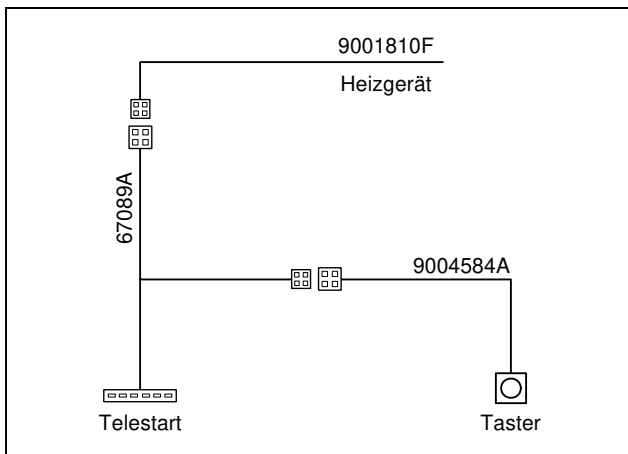
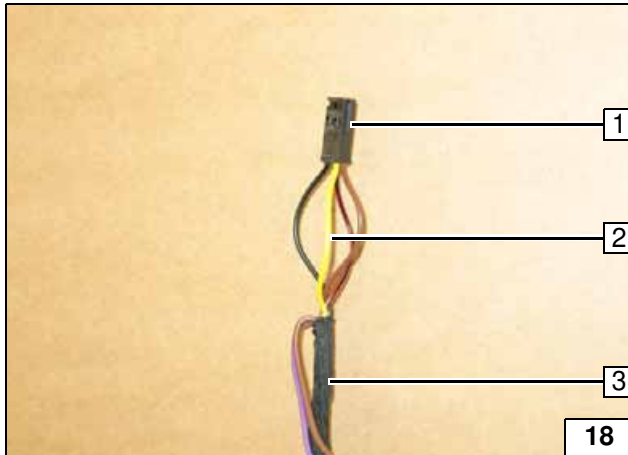

Diagram of standard heater controls



Combination of digital timer, Telestart and/or Thermo Call with push button



Mount yellow (ge) wire 2 in free socket of 4-pin connector 1 of heater-unit wiring harness 3.



Preparing wiring harness of heater unit

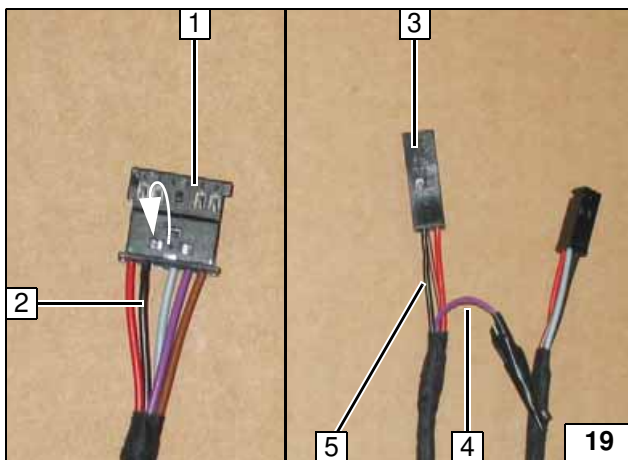

Move black (vi) wire 2 from socket 3 to socket 2 in 6-pin connector of Telestart 1.

Remove violet (vi) wire 4 from socket 1 from 4-pin connector housing 3, insulate and tie back.

Remove black (sw) wire 5 from socket 2 and insert in socket 1.



Preparing adapter wiring harness (67089A)

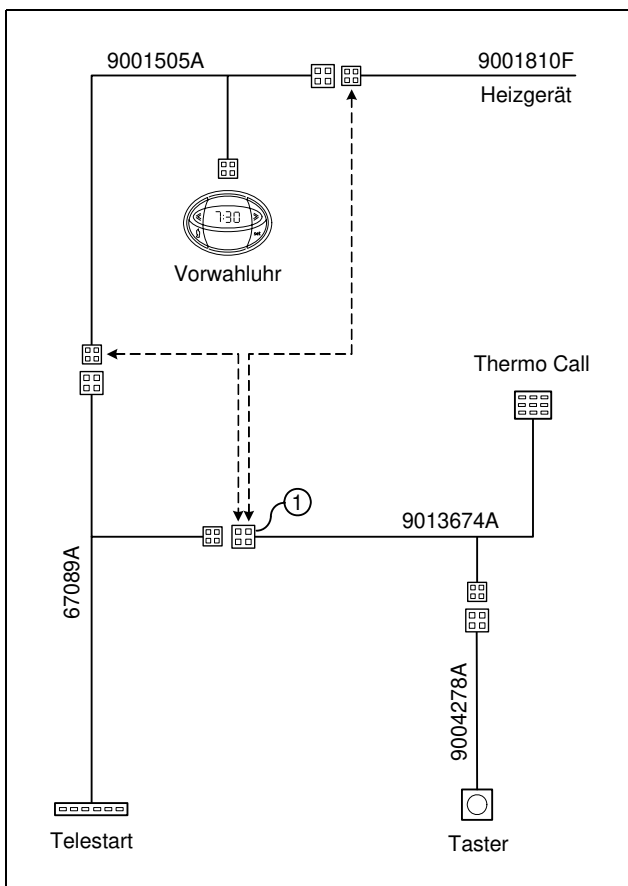

Selection of individual heater controls can be combined with each other!

WARNING:

1 Insert yellow (ge) wire in free socket



Diagram of optional heater controls

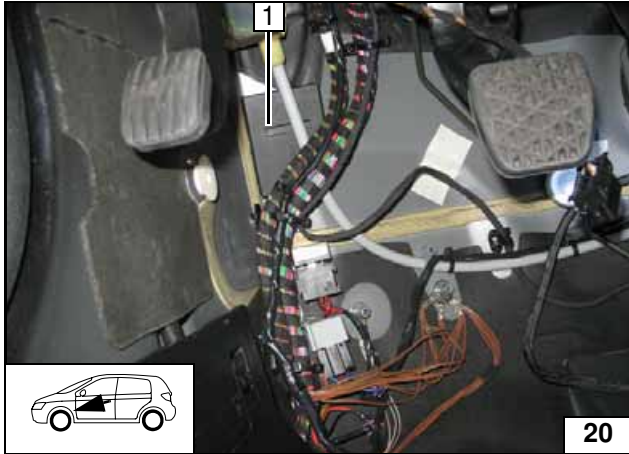

Telestart

1 Receiver, adhesive tape



Installing receiver



Glue antenna 1 onto windshield, if possible in black area.



Installing antenna

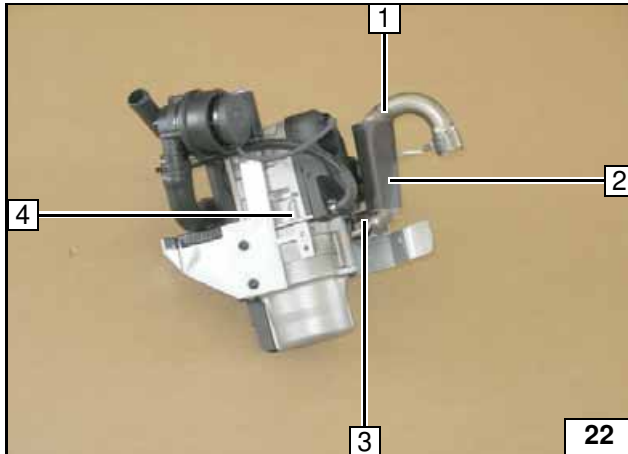
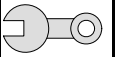

Preparing heater unit

- 1 Exhaust pipe
- 2 Pipe insulation, 80 mm
- 3 Hose clamp
- 4 Heater unit



Premounting ex-haust pipe

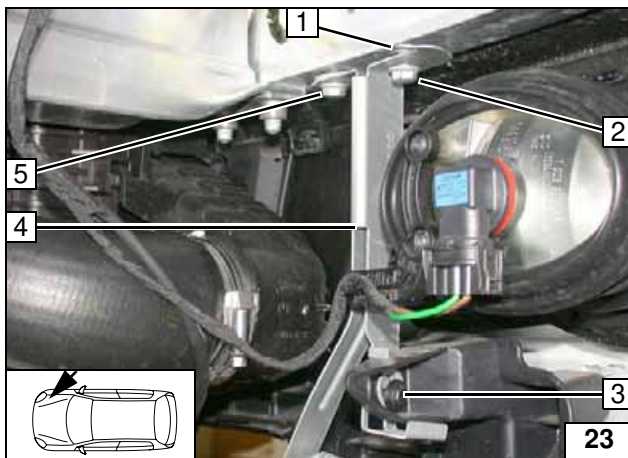

Preparing installation location

Figure shows W204!
Loosen original vehicle bolt at position 2, 3 and 5. Insert large diameter washer at position 5 between bracket 4 and bumper. Tighten bolts at position 3 and 5.
Bend twist protection at position 1 toward rear. If necessary, twist cylinder of headlight washer system and fix in place with cable tie (ensure sufficient spacing between connector of front fog light and bracket of heater unit).



Detaching bracket

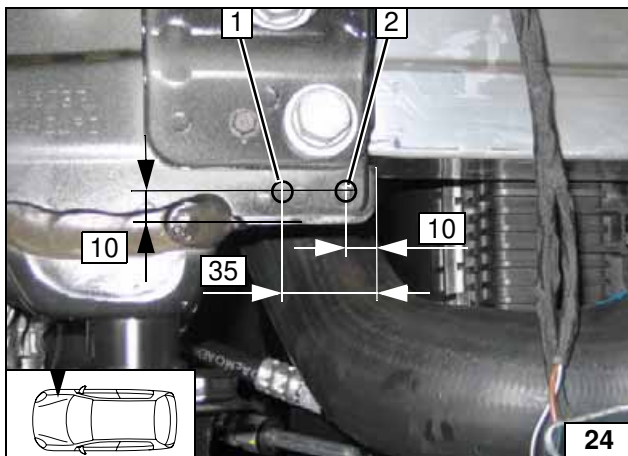

Remove joint sealer on inside of frame side member in area of holes 1 and 2 respectively.

S204 and W204

1 7 mm dia. hole

X204

2 7 mm dia. hole



Hole in frame side member

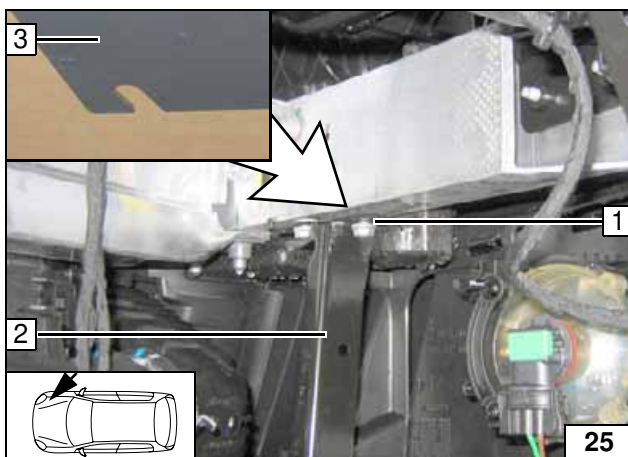
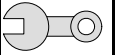

Figure shows X204!
Mount heating unit bracket 3 with oblong hole between detached bracket 2 and bumper at position 1.

- 1 Original vehicle bolt



Mounting heater unit



S204 and W204

When drilling, watch components located behind.

- 1 M6x20 bolt, flanged nut



Loosely mounting heater unit

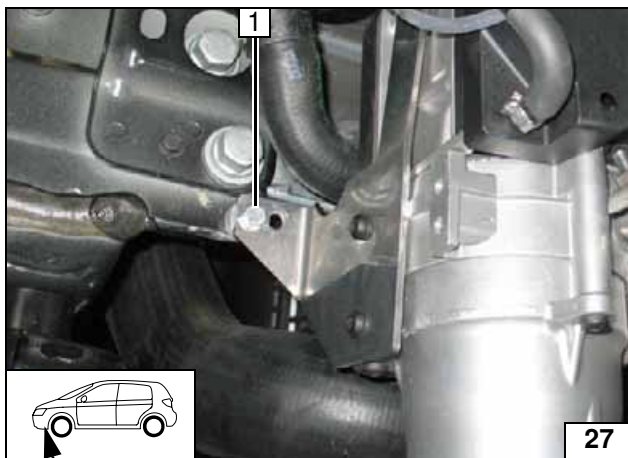

X204

Insert 8 mm shim between bracket of heater unit and frame side member.

- 1 M6x25 bolt, 8 mm shim, flanged nut



Loosely mounting heater unit

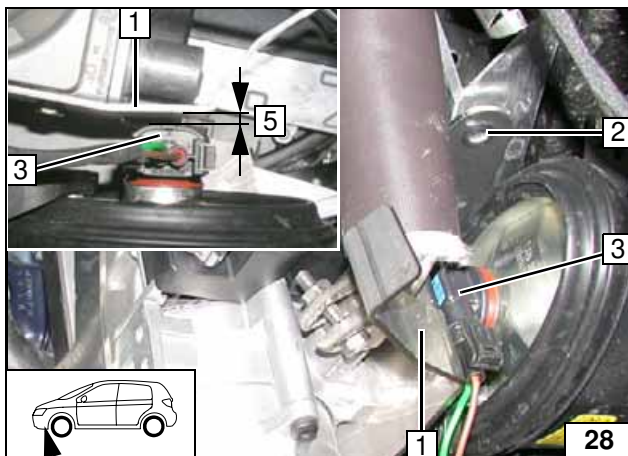

S204 and W204

Ensure proper spacing between connector of front fog light 3 and bracket of heater unit 1 (at least 5 mm).

- 2 Copy 7 mm dia. hole pattern



Copying hole pattern

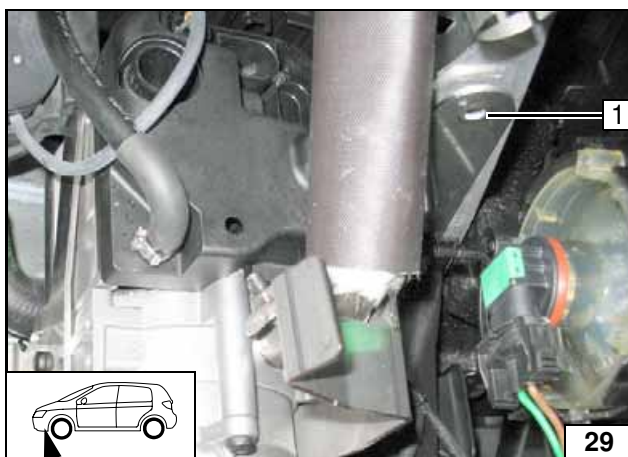

X204

- 1 Copy 7 mm dia. hole pattern

Copying hole pattern

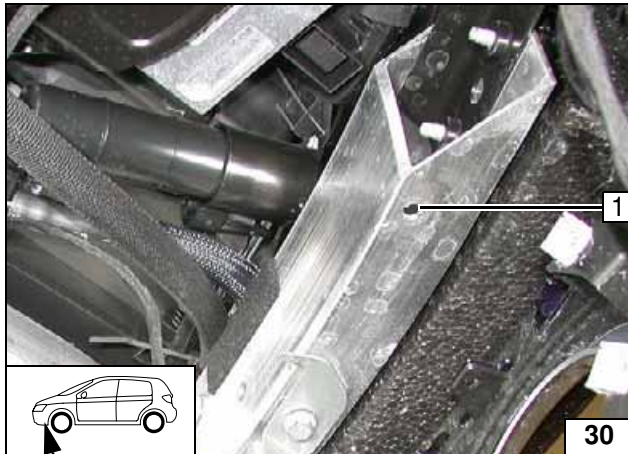
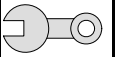

Figure shows W204!
Remove heater unit. Remove front fog light for 7 mm dia. hole.

1 7 mm dia. hole [2x]



Hole in bumper



Figure shows W204!
Mount M6x20 bolt 1 in hole and secure with pin lock.
Remount front fog light and horn.



Mounting front fog light and horn

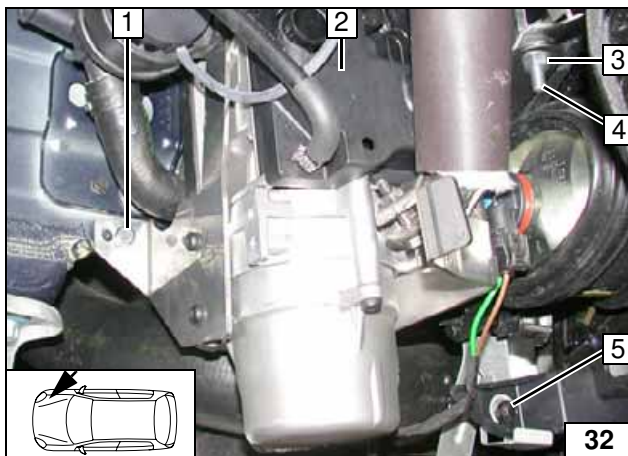

Installing heater unit

S204 and W204

Mount bracket of heater unit 2 on bolt 4, between detached bracket and bumper. Align heater unit and fasten at position 1 and 4. Check distance to front fog light. Tighten original vehicle bolt at position 5. Tighten bolt on retaining strut.

- 1 M6x20 bolt, flanged nut
- 3 Flanged nut



Installing heater unit

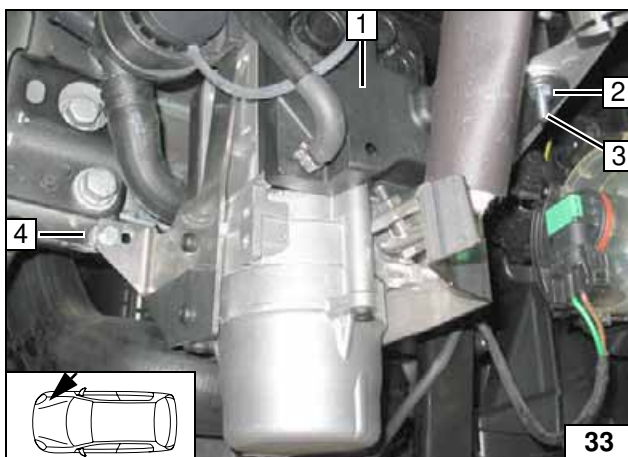

X204

Mount bracket of heater unit 1 on bolt 3, between detached bracket and bumper. Insert 8 mm shim between bracket of heater unit and frame side member at position 4. Align heater unit and fasten at position 4 and 3. Tighten bolt on retaining strut.

- 2 Flanged nut
- 4 M6x20 bolt, 8 mm shim, flanged nut



Installing heater unit

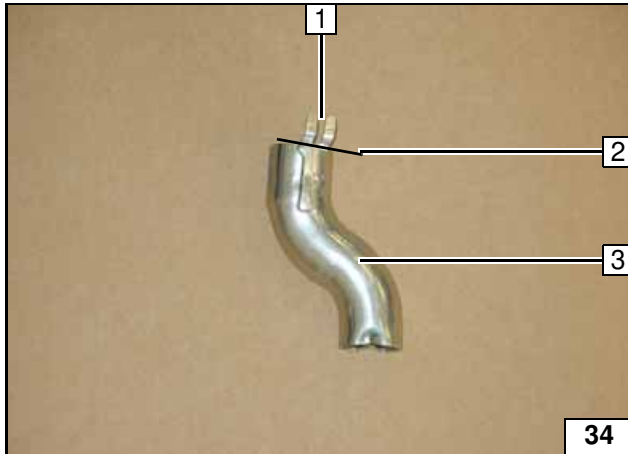
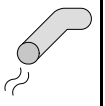

Exhaust gas

Cut tab 1 off exhaust end section 1.

2 Cutting point



Preparing exhaust end section

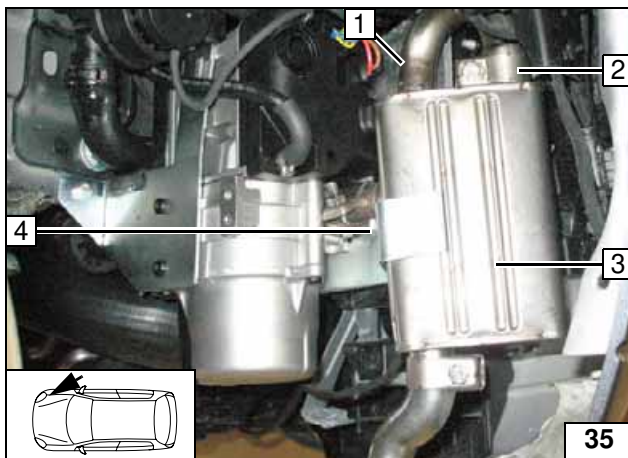

Mount exhaust muffler 3 on exhaust pipe 1 and align relative to hole 4.

2 Hose clamp

4 M6x12 bolt, spring lockwasher



Installing muffler

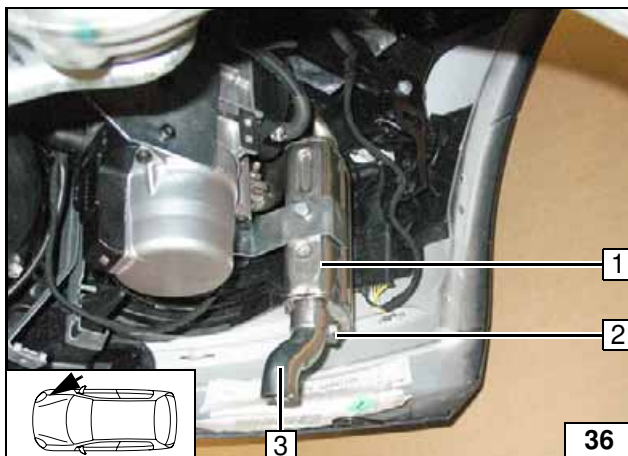

Ensure sufficient distance to neighboring components.

S204 and W204

Slide incomplete exhaust end section 3 onto exhaust muffler 1 (5 mm distance between end section 3 and muffler 1), align and fasten.

X204

Slide complete exhaust end section 3 onto exhaust muffler 1.

2 Hose clamp



Installing exhaust pipe and end section

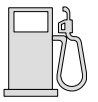

Fuel

CAUTION!

Open the vehicle's fuel tank cap, ventilate the tank and then re-close the tank lock.

Catch any fuel running off with an appropriate container.

Install fuel line and metering-pump wiring harness so that they are protected against stone impact. Unless specified otherwise, always fasten using cable ties. Mount the fuel line and wiring harness with rub protection on sharp edges.

WARNING!

The fuel line and wiring harness are routed to the metering pump in as shown in the wiring harness routing diagram.

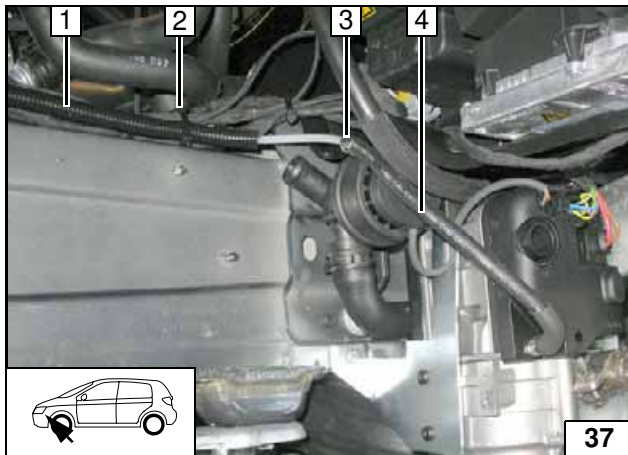

All vehicles

Pin out connector housing of metering-pump wiring harness before pulling into corrugated tube.

- 1 9 mm dia. corrugated tube, wiring harness of metering pump
- 2 Cable tie
- 3 Fuel line, 10 mm dia. clamp
- 4 Molded hose of heater unit

Connection to heater unit

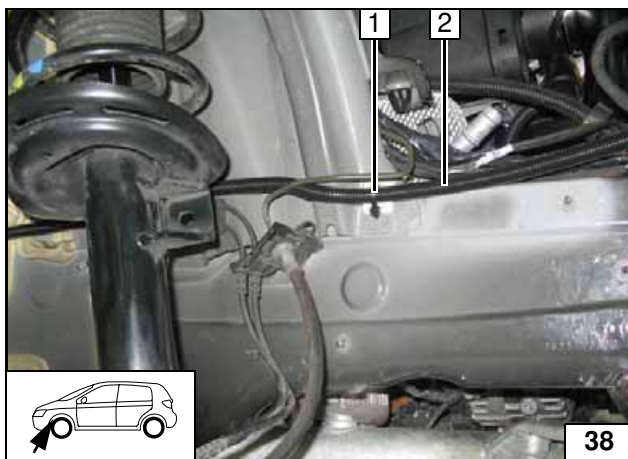

Degrease adhesive surface for adhesive base 1.

- 1 Adhesive base, cable tie
- 2 Corrugated tube

Installing lines

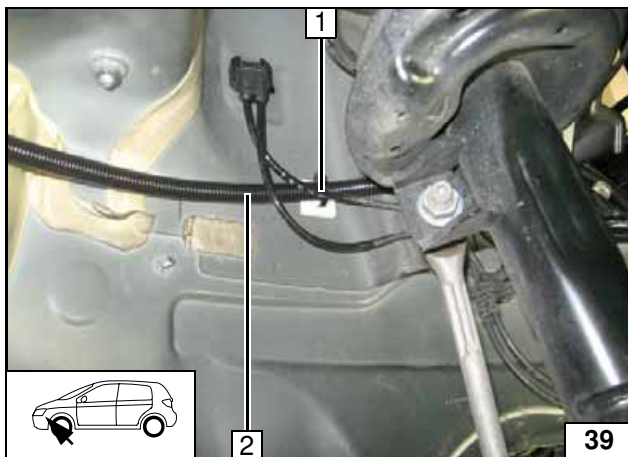

Degrease adhesive surface for adhesive base 1.

- 1 Adhesive base, cable tie
- 2 Corrugated tube

Installing lines

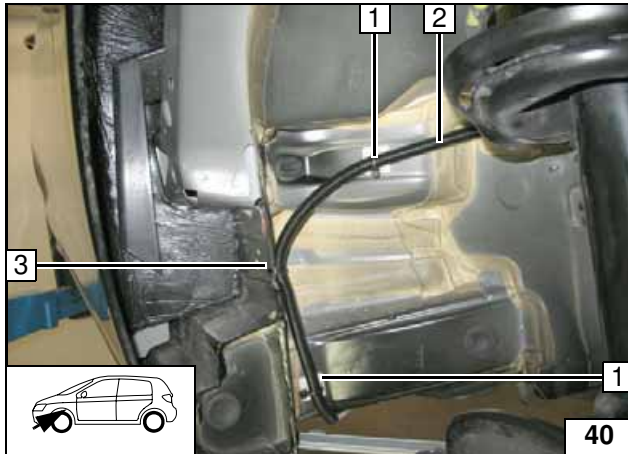
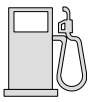

Degrease adhesive surface for adhesive base 1.

- 1 Adhesive base [2x], cable tie [2x]
- 2 Corrugated tube
- 3 Cable tie, existing hole



Installing lines

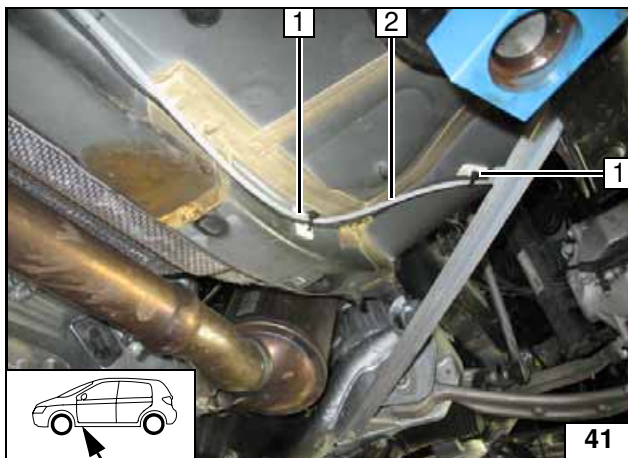

Degrease adhesive surface for adhesive base 1.

- 1 Adhesive base [2x], cable tie [2x]
- 2 Fuel line, wiring harness of metering pump



Installing lines

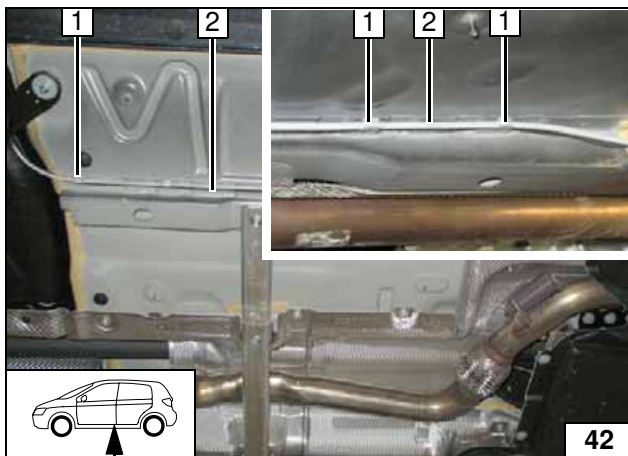

Distribute retaining clips 1 [10x] evenly along vehicle underbody and insert fuel line 2 and wiring harness of metering pump 2.



Installing lines

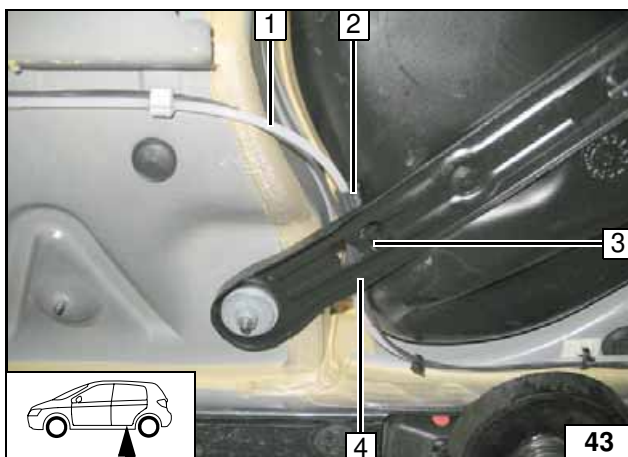

- 1 Fuel line, wiring harness of metering pump
- 2 Dia. 8x12 hose piece
- 3 Cable tie
- 4 Original vehicle retaining strap

Installing lines

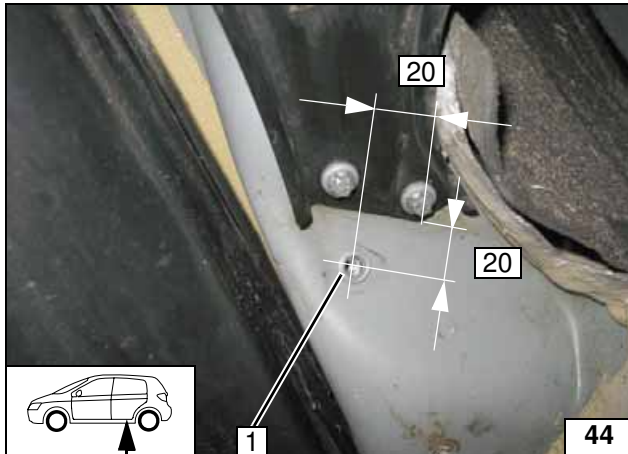

S204 and W204

Drill 9.1 mm dia. hole 1, mount M6 rivet nut.



Rivet nut for metering pump

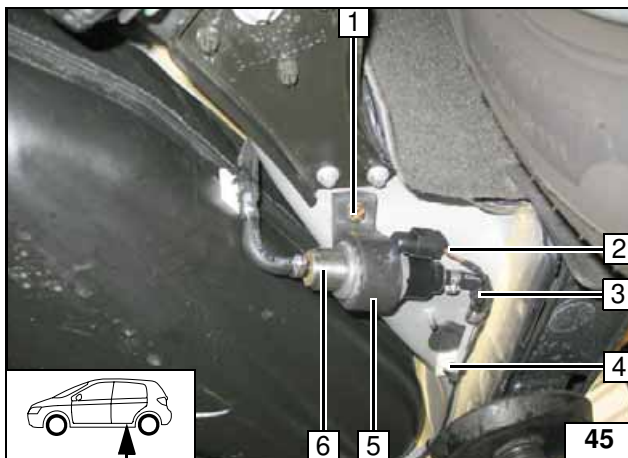

Mount connector housing of ing pump cable 2 on wiring harness again. Degrease adhesive surface for adhesive base 4.



Installing metering pump

- 1 M6x25 bolt
- 2 Metering pump connector
- 3 90° molded hose, 10 mm dia. clamp [2x], fuel line
- 4 Adhesive base, cable tie
- 5 Mount
- 6 Metering pump

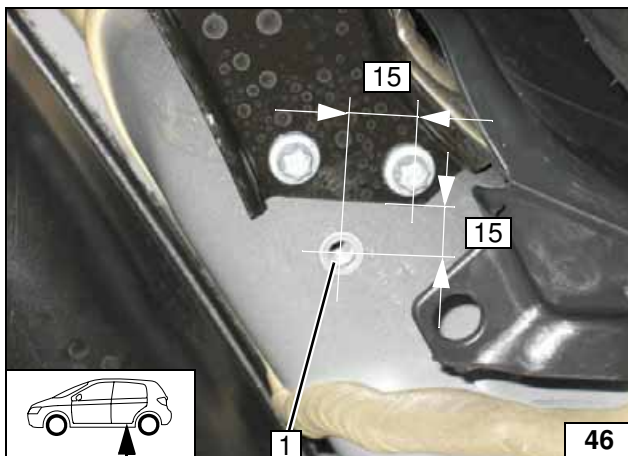

X204

Drill 9.1 mm dia. hole 1, mount M6 rivet nut.



Rivet nut for metering pump

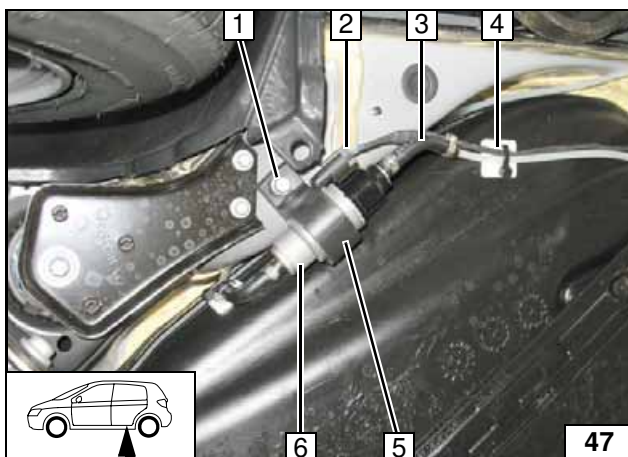

Mount connector housing of ing pump cable 2 on wiring harness again. Degrease adhesive surface for adhesive base 4.



Installing metering pump

- 1 M6x25 bolt
- 2 Metering pump connector
- 3 90° molded hose, 10 mm dia. clamp [2x], fuel line
- 4 Adhesive base, cable tie
- 5 Mount
- 6 Metering pump

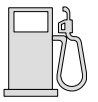

Observe tightening torque 5 Nm of flanged nut **6** on fuel standpipe **7**.
Mount 3.5 mm dia. molded hose **4** on fuel standpipe **7**.

- 1** Fuel-tank sending unit
- 2** Standpipe
- 3** 10 mm dia. clamp
- 5** 8 mm dia. clamp



Installing fuel standpipe

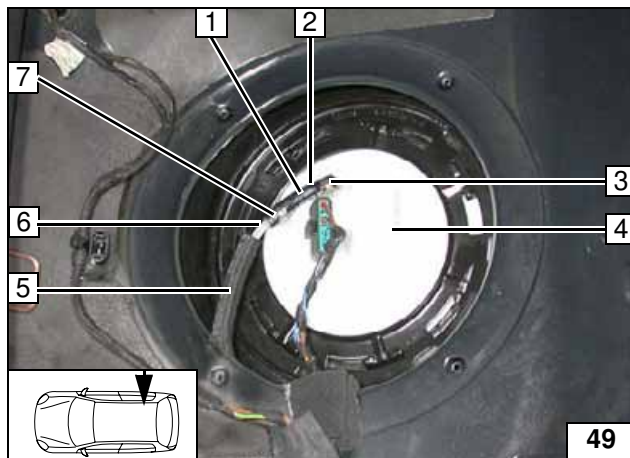

Install fuel-tank sending unit **4** in accordance with manufacturer's specifications.
Mount 3.5 mm dia. hose **1** on fuel standpipe **3**.

- 2** 8 mm dia. clamp
- 5** 6x11 hose (rattle protection)
- 6** Fuel line
- 7** 10 mm dia. clamp



Installing line

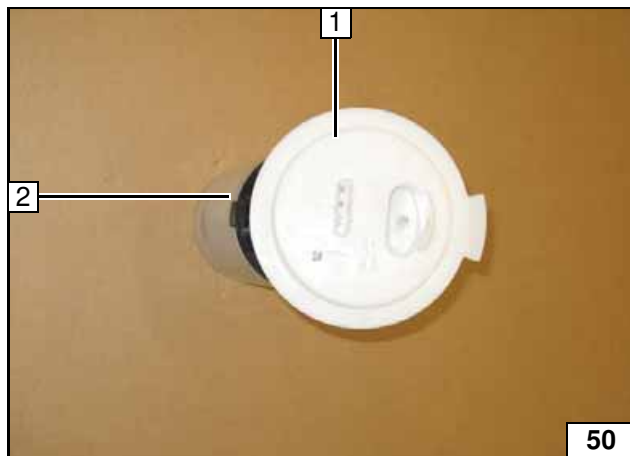

Version 2

Remove fuel-tank sending unit in accordance with manufacturer's instructions.

Remove upper section **1** from lower section **2** in accordance with manufacturer's instructions.



Removing fuel

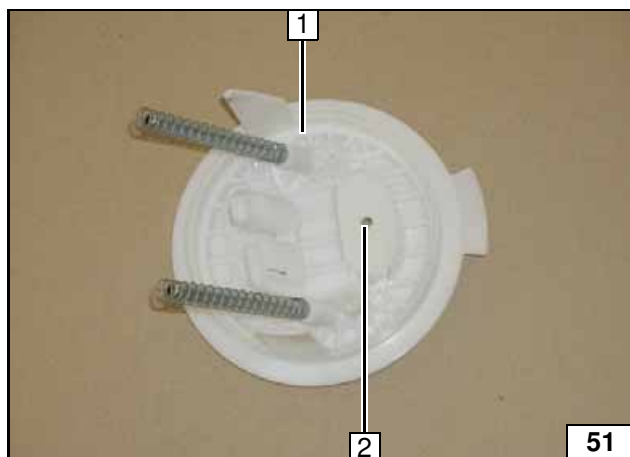

Cut off connection piece **2** flush on underside **1**. Drill 6 mm dia. hole in center.



Removing fuel

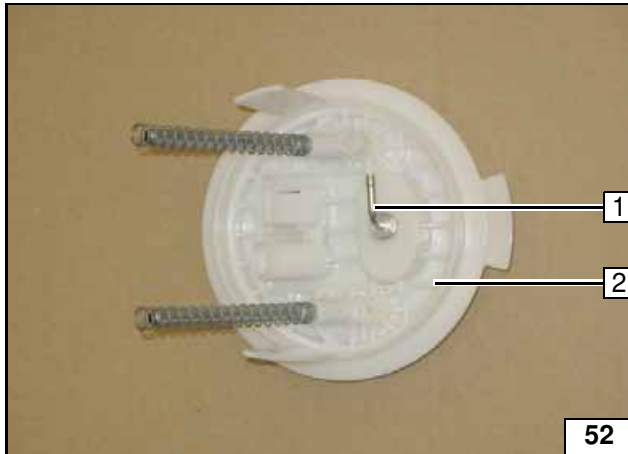

Insert fuel standpipe 1 in upper section of fuel-tank sending unit 2



Removing fuel

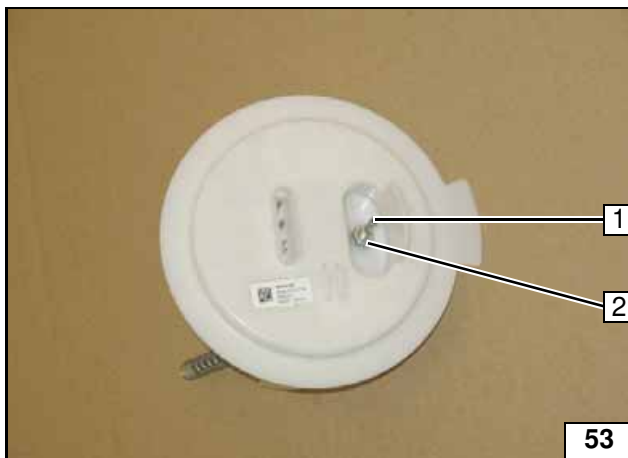

Observe tightening torque 5 Nm of flanged nut 2 on fuel standpipe 1.



Removing fuel

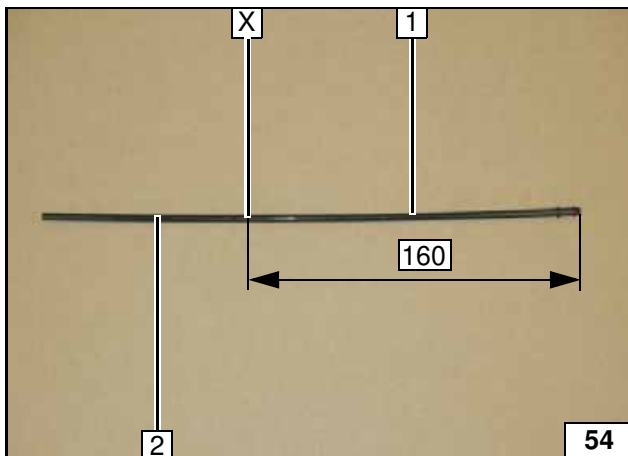

Cut off standpipe 1 at an angle at position X.

2 Section, discard



Cutting standpipe to size

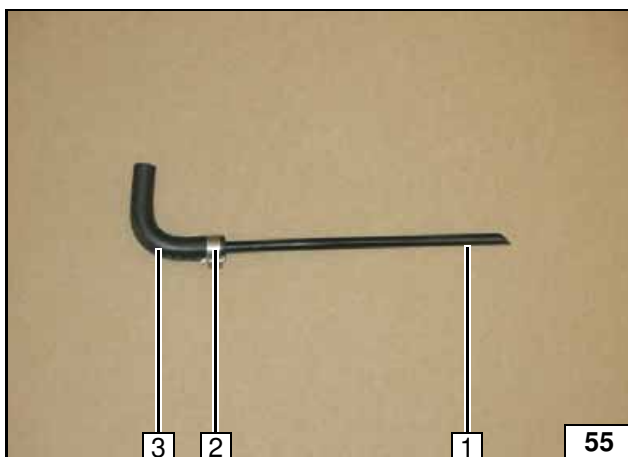

Mount standpipe 1 in 4.5 mm dia. molded hose 3.

2 10 mm dia. clamp



Premounting standpipe

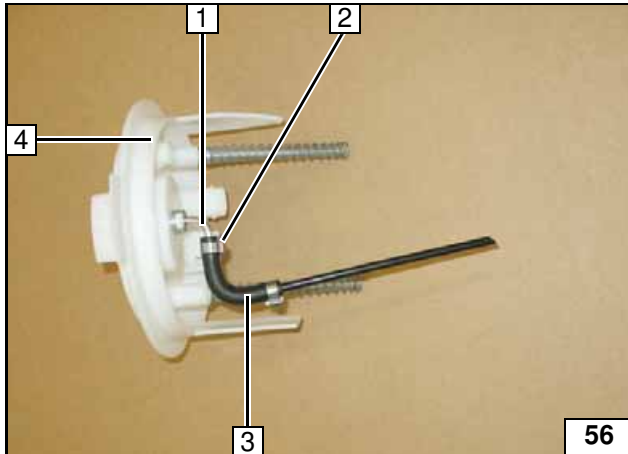
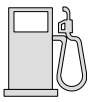

Premount standpipe 3 on fuel standpipe 1 and secure with 8 mm dia. clamp 2.

4 Fuel-tank sending unit



Installing standpipe

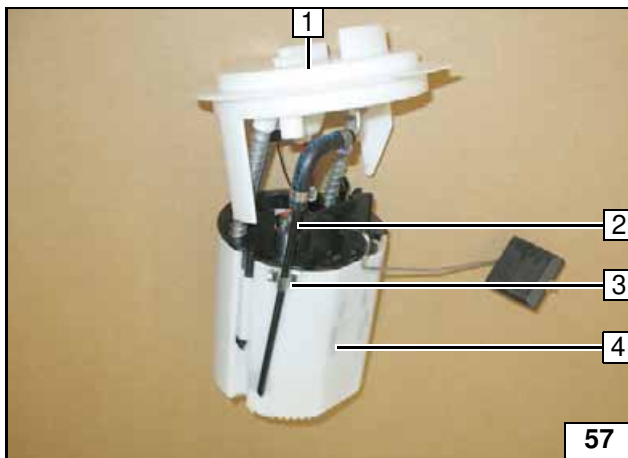

Install fuel-tank sending unit 1 in accordance with manufacturer's specifications. Insert line holder 3 for guiding standpipe 2 in lower section of fuel-tank sending unit 4.



Installing standpipe

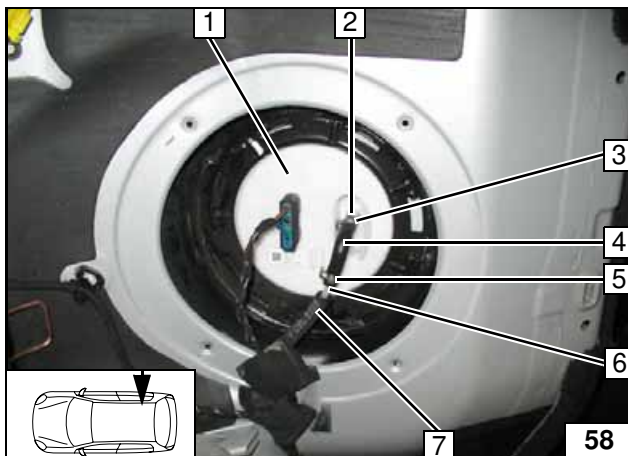

Install fuel-tank sending unit 1 in accordance with manufacturer's specifications. Mount 3.5 mm dia. molded hose 4 on fuel standpipe 2.

- 3 8 mm dia. clamp
- 5 10 mm dia. clamp
- 6 Fuel line
- 7 6x11 hose (rattle protection)



Installing line

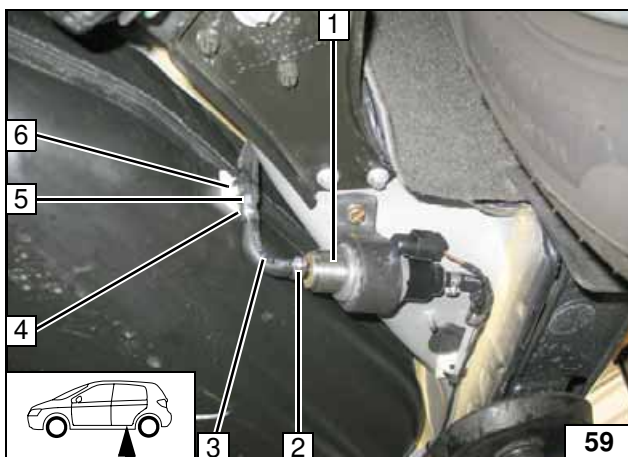

S204 and W204

Degrease adhesive surface for adhesive base 6.

- 1 Metering pump
- 2 10 mm dia. clamp
- 3 90° molded hose
- 4 10 mm dia. clamp
- 5 Fuel line
- 6 Cable tie, adhesive base

Connecting to metering pump

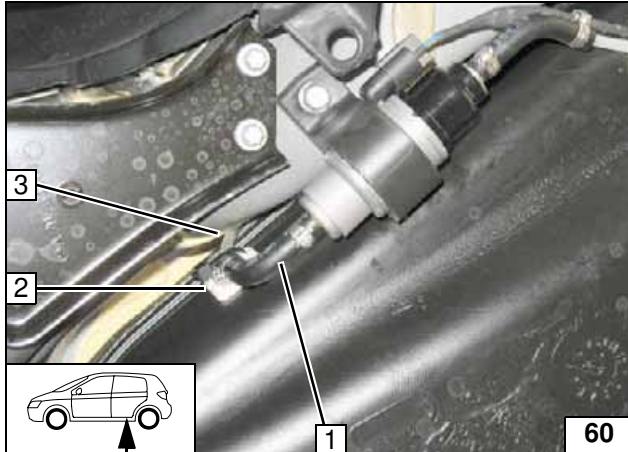

X204

Degrease adhesive surface for adhesive base 2.

- 1 90° moulded hose, 10 mm dia. clamp
- 2 Cable tie, adhesive base
- 3 Fuel line



**Connect-
ing meter-
ing pump**



Coolant connection
C180 K, C200 K without electr. circulating pump



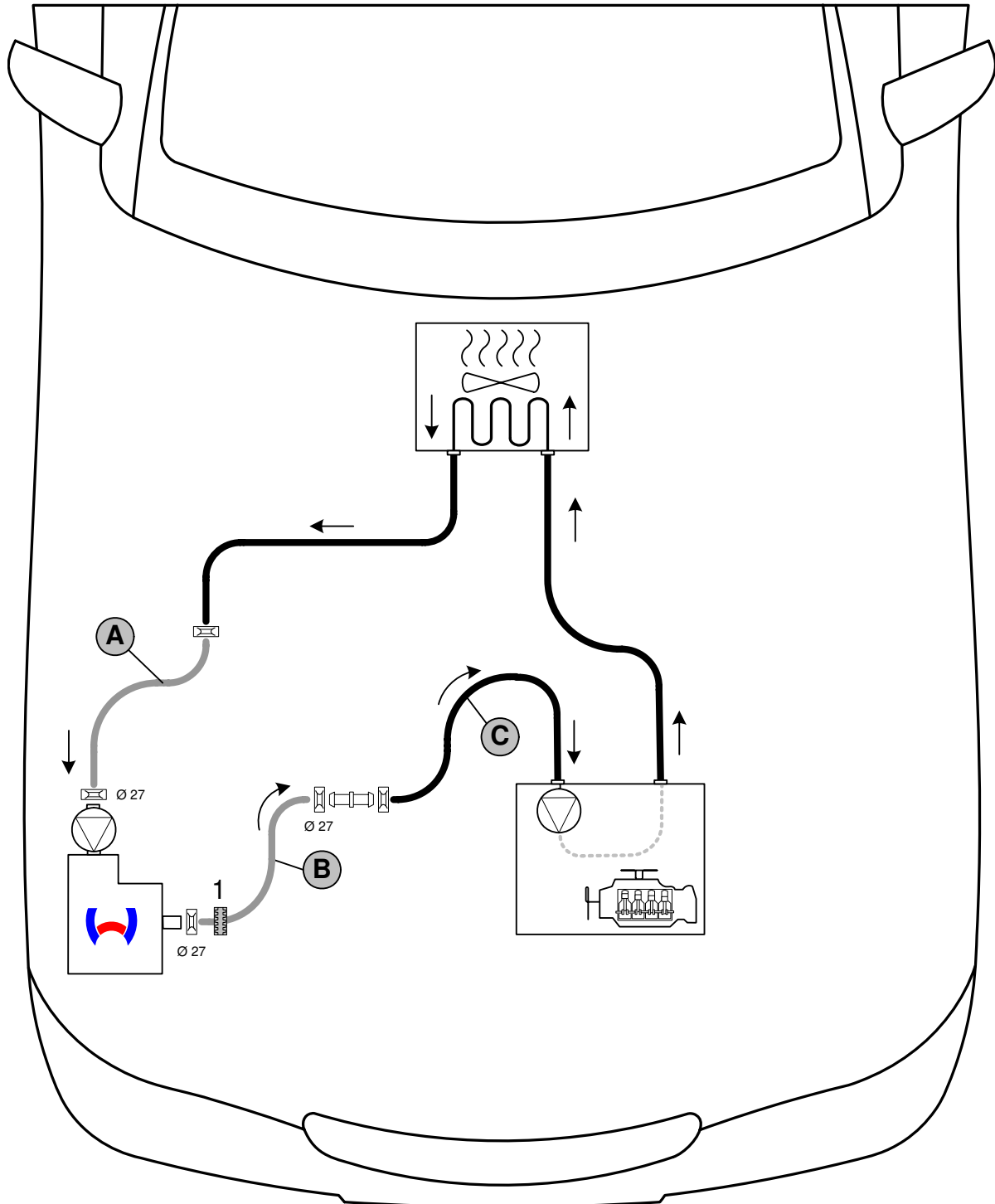

WARNING!

Any coolant running off should be collected using an appropriate container. Install coolant hoses kink-free. Unless specified otherwise, always fasten using cable ties. Position clamps so that no other hose can be damaged! When installing the coolant hose, the heater unit must be filled with coolant. The connection should be "inline" based on the following diagram:



Coolant routing diagram

All spring clips without a specific designation  = 25 mm dia. Connecting pipe  = 18x20 dia.
1 = Black (sw) rubber isolator .



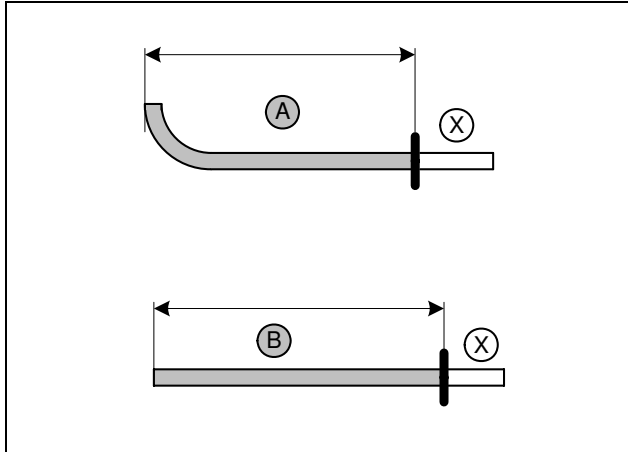

Discard section **X**.

A = 18 mm dia., length = 210
B = 20 mm dia., length = 265

**Cutting
coolant
hoses to
length**

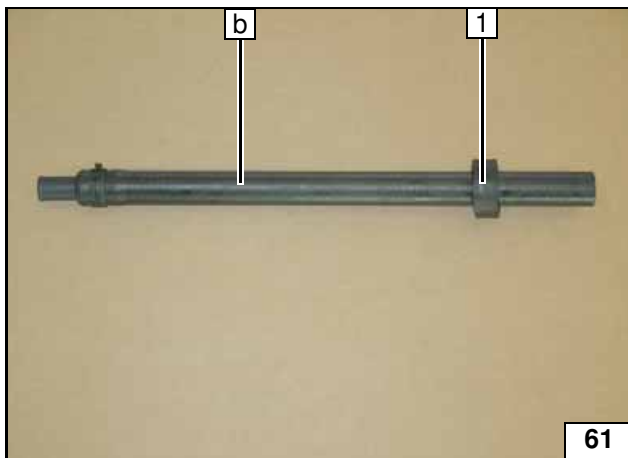

1 Black (sw) rubber isolator

**Preparing
coolant
hose**

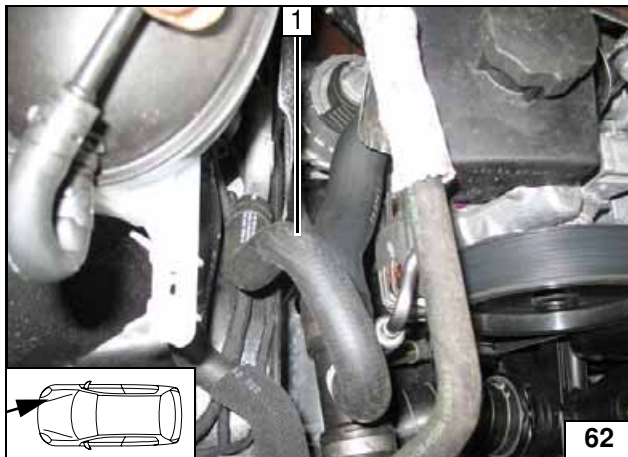

Remove original vehicle hose **1**; hose will be reused.



**Cutting
point**

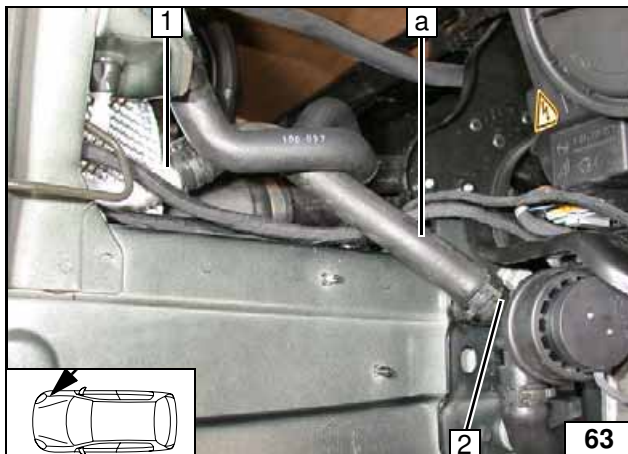

1 Connection to pipe socket on heat exchanger outlet
2 Connection to heater-unit circulating pump



**Connec-
tion to
heater unit**

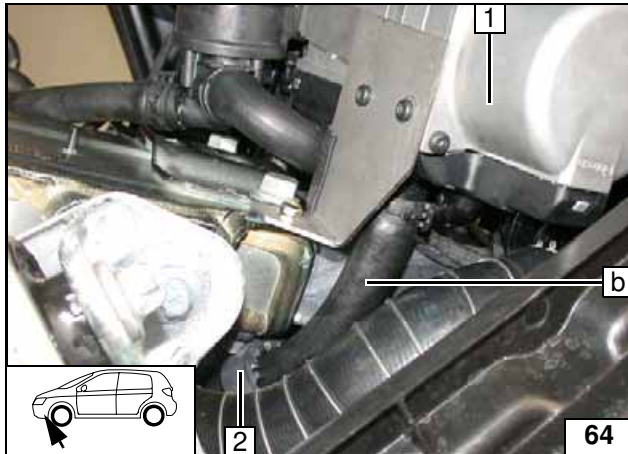
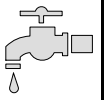

Align black (sw) rubber isolator 2.

1 Heater unit



Conne-
tion to
heater unit

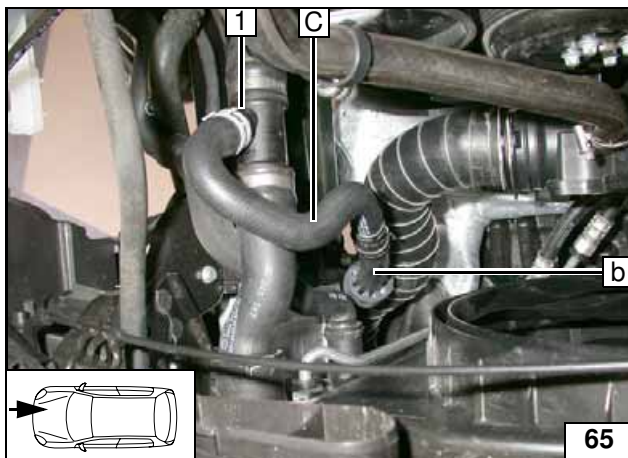

Hose C turned on connection piece 1.



Conne-
tion on en-
gine inlet



**C230, C280, C350, GLK280, GLK350
with electr. circulating pump**



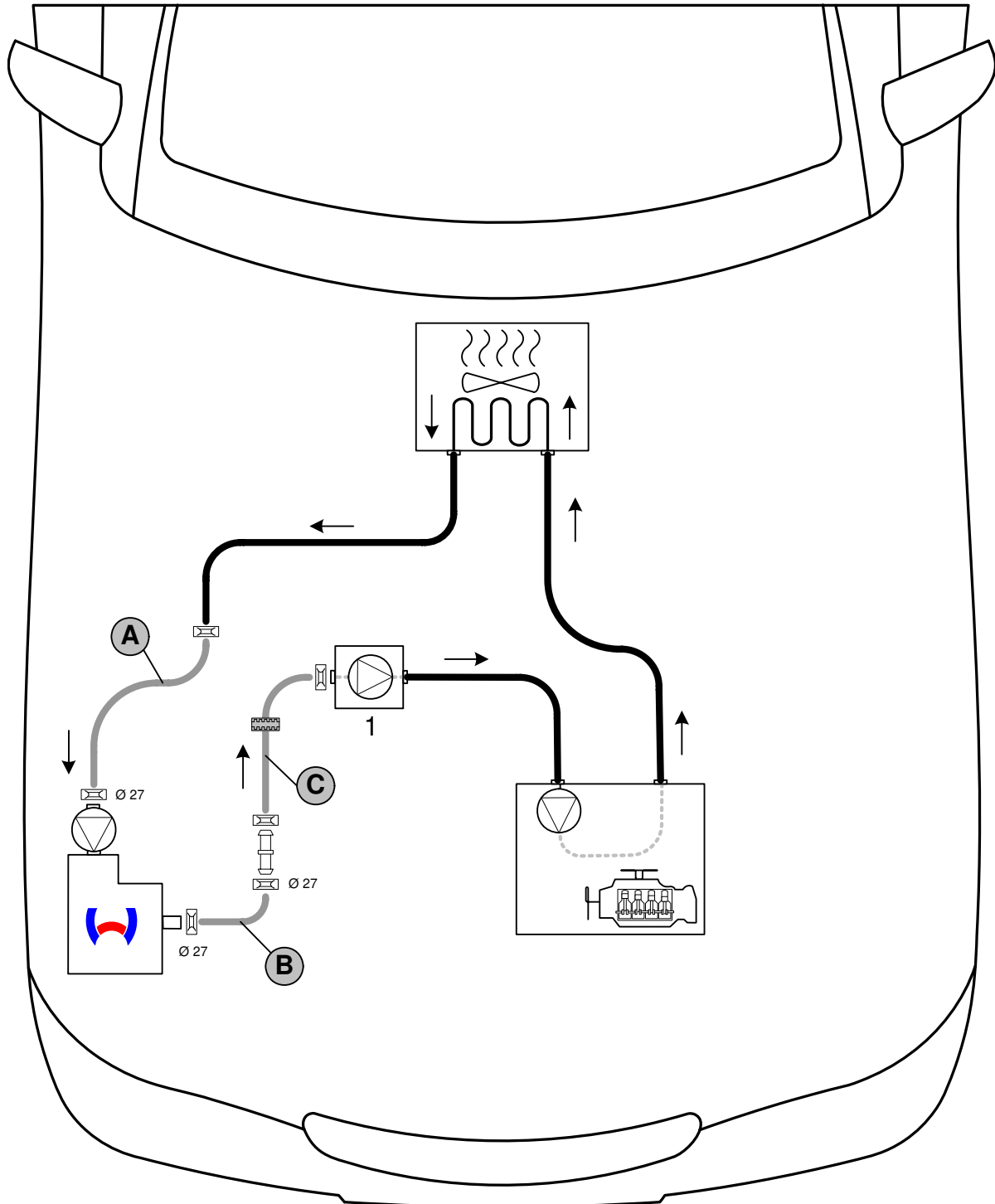

WARNING!

Any coolant running off should be collected using an appropriate container. Install coolant hoses kink-free. Unless specified otherwise, always fasten using cable ties. Position clamps so that no other hose can be damaged! When installing the coolant hose, the heater unit must be filled with coolant. The connection should be "inline" based on the following diagram:



Coolant routing diagram

All spring clips without a specific designation  = 25 mm dia. Connecting pipe  = 18x20 dia.
1 = Original vehicle circulating pump.  = black (sw) rubber isolator.



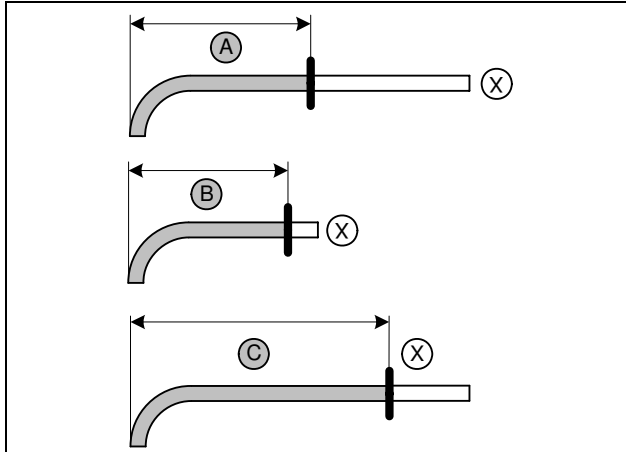

Discard section **X**.

- A = 18 mm dia., length = 210
- B = 20 mm dia., length = 150
- C = 18 mm dia., length = 355

Cutting coolant hoses to length

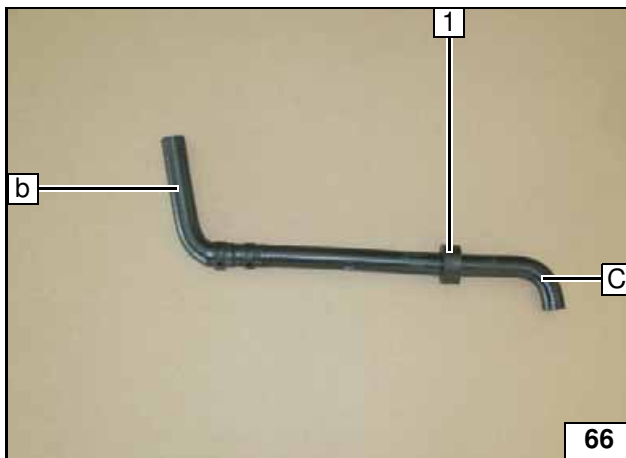

1 Black (sw) rubber isolator

Preparing coolant hose

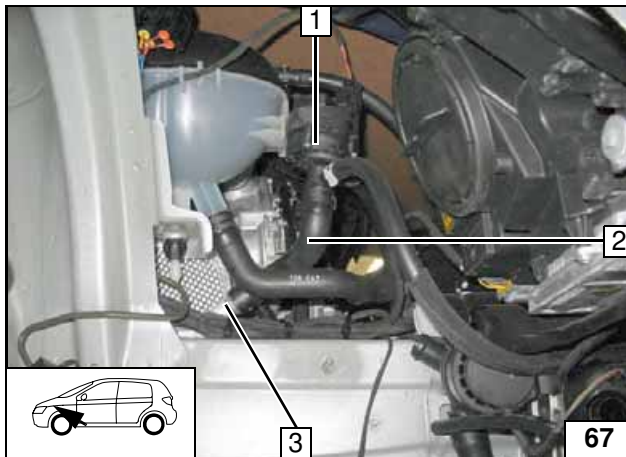

Remove original vehicle hose **2**; hose will not be reused.

- 1** Original vehicle circulating pump
- 3** Connection to pipe socket on heat exchanger outlet



Cutting point

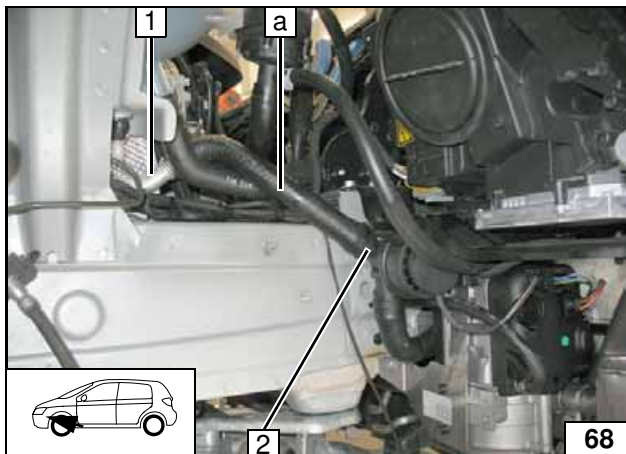

- 1** Connection to pipe socket on heat exchanger outlet
- 2** Connection to heater-unit circulating pump



Connection to heater unit



1 Connection to heater unit outlet

Con-
nec-
tion to
heater unit

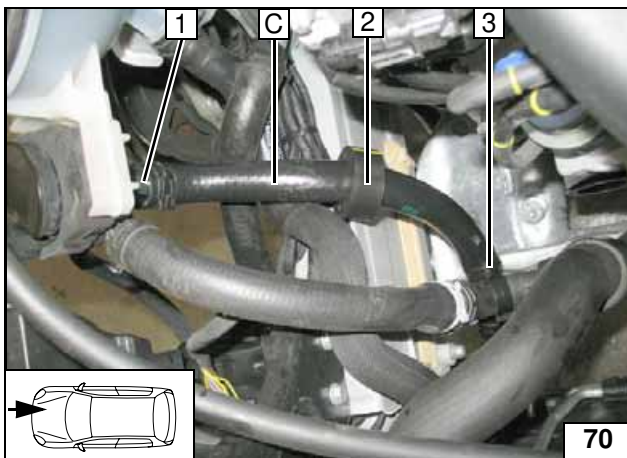

Align black (sw) rubber isolator 2.

- 1 Connection piece of original vehicle circulating pump
- 3 Hose bracket



Con-
nec-
tion to wa-
ter pump

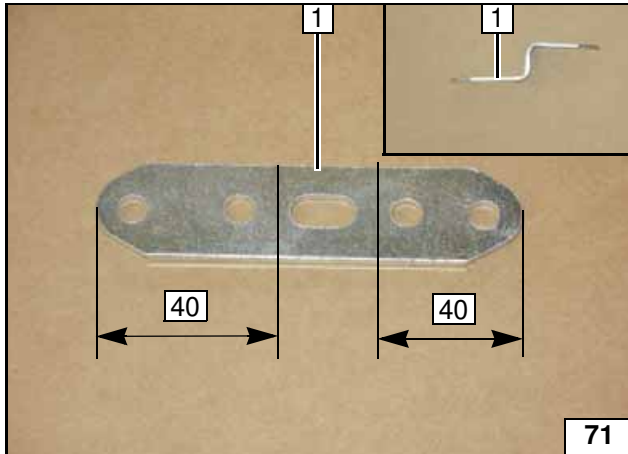
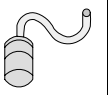

Combustion air

Bend perforated bracket 1 2x 90°.



Bending perforated bracket



Vehicle without electr. circulating pump

- 1 Combustion-air intake pipe
- 2 Heater unit
- 3 9x19 hose bracket [2x]
- 4 Hose bracket



Installing intake pipe

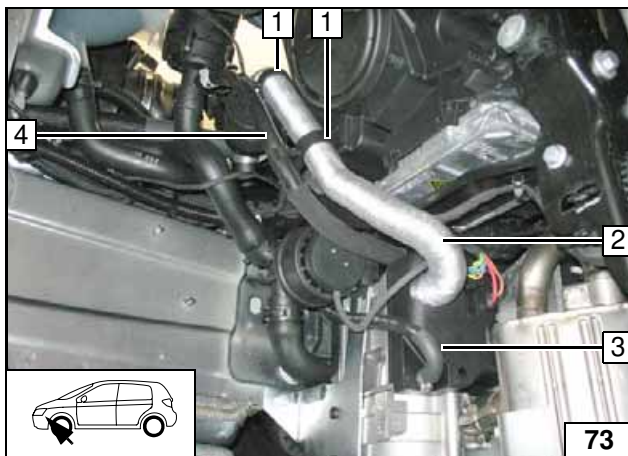

Vehicle with electr. circulating pump

Position 9x19 hose bracket 1 [2x] between combustion air pipe 2 and original vehicle hose 4.

- 3 Heater unit



Installing intake pipe

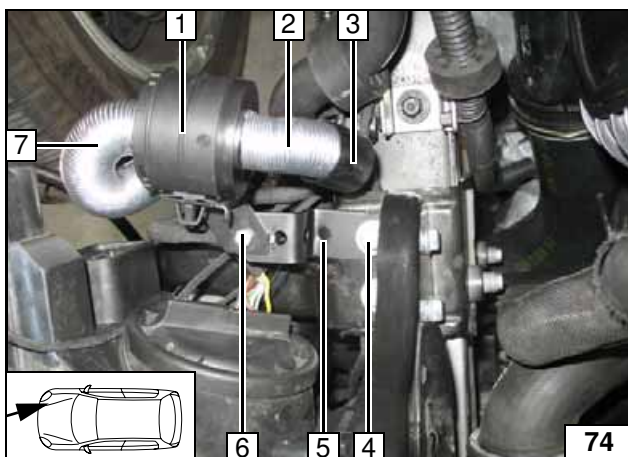

Mount perforated bracket 5 with original vehicle bolt 4.

- 1 Intake muffler
- 2 Intake pipe
- 3 Protective cap
- 6 Bracket of muffler, M5x16 bolt, washer, flanged nut
- 7 Intake pipe



Installing muffler

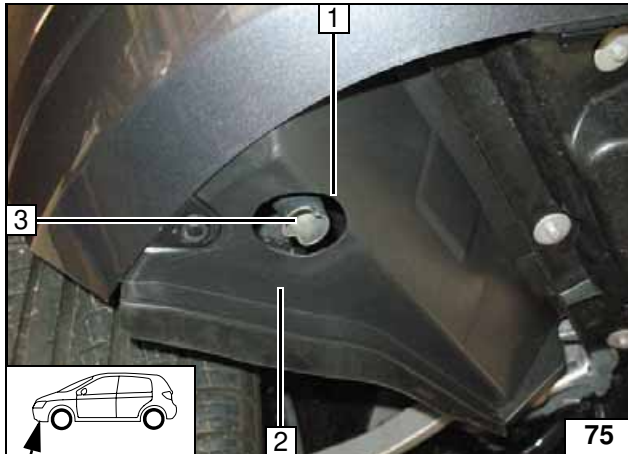
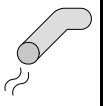

Aligning exhaust end section

S204 and W204

Drill 45 mm dia. hole 1 in trim 2.

The exhaust end section 3, must be centered relative to the hole 1 and aligned flush with the trim 2; realign exhaust end section 3 if necessary.

3 Exhaust end section

1 Exhaust end section



Aligning exhaust end section



Aligning exhaust end section

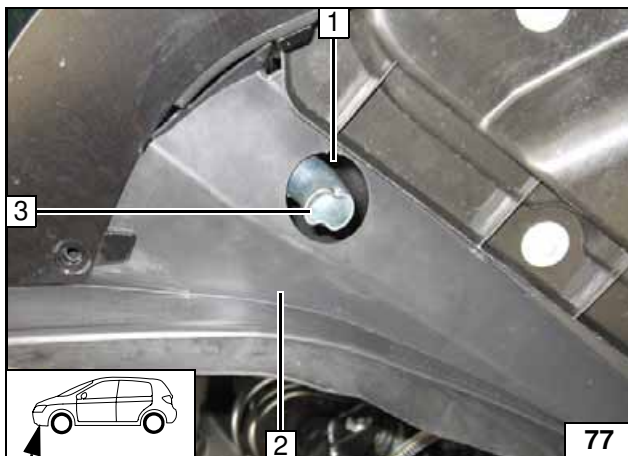

X204

Drill 45 mm dia. hole 1 in trim 2.

The exhaust end section 3, must be centered relative to the hole 1 and aligned flush with the trim 2; realign exhaust end section 3 if necessary.

3 Exhaust end section

1 Exhaust end section



Aligning exhaust end section



Aligning exhaust end section



Final Work

WARNING!

Reassemble the disassembled components in reverse order.

Check all hoses, clamps and all electrical connections for firm seating.

Secure all loose cables using cable ties.

Only use manufacturer-approved coolant.

Spray heater unit components with anti-corrosion wax (Tectyl 100K, Order No. 111329).

- Fill and bleed the coolant circuit according to the vehicle manufacturer's specifications.
- Check the proper operation of the additional heater, see the operating instructions/installation instructions.
- Attach the "Switch off additional heater before refueling" sticker to the left-hand B-pillar.
- Teach button function as described in operating instructions (remove fuse F2 [1A], install again and press button for 2 sec. within 5 sec.)

Note:

When switching on the heater unit with the digital timer and switching off with the Thermo Call, the Thermo Call must first be switched on and then off!

The additional ventilation function is not possible!

WARNING:

After conducting an operating test of the additional heater, carry out an "input short test" with the "Diagnosis assistance system" of the manufacturer on the vehicle.

Reprogram the positioning motors in the KLA air conditioner.



Webasto AG
Postfach 80 - 82132 Stockdorf
Hotline 01805 / 932278 - Hotfax 0395 / 5592-353
<http://www.webasto.de>