

Thermo Top

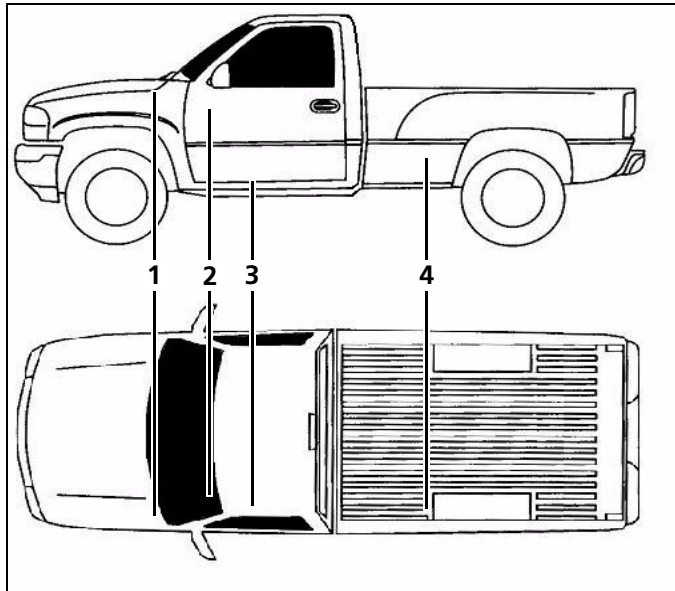

GMC Sierra 2500 HD
GMC Sierra 3500 HD
 6.6 Liter Duramax Diesel
 Beginning Model Year: 2000

Chevrolet Silverado 2500 HD
Chevrolet Silverado 3500 HD
 6.6 Liter Duramax Diesel
 Beginning Model Year: 2000

Special instructions for these models

Part locations may differ slightly dependent on the vehicle model.

Legend

- 1 Fuse Holder, Relays and Resistor Assembly
- 2 Timer Control
- 3 BlueHeat Coolant Heater, Exhaust Tube, and Combustion Air Intake Silencer
- 4 Fuel Pump

Special Tools

- Hose Clamping pliers
- Torque Wrench

Table of Contents

Foreword

Parts List	3
Vehicle Information	3
Scope and Purpose	3
Symbol Identification	4
General References	5
Preparation	5
Heater Installation Site	5

Installation

Electrical - Overview	6
Electrical Harness	7
Timer Installation	7
Fuse Tap Connection - Relay K-1	8
Integration into the Blower System	8
3-Relay HVAC Harness Connections	9
Heater Preparation	11
Heater Installation Site Preparation	12

Heater Installation (Underbody Mount)	13
Exhaust Installation	13
Combustion Air Intake Installation	13
Integration into the Coolant System	14
Integration into the Fuel System	16
Fuel Pump Installation	16
Fuel Line Routing	16
Standpipe Installation - 2000 Through 2003	18
Standpipe Installation - 2004/2006 Model Year	20
Fuel Line Routing from Sender to Pump	22
Power Connection	23
Final Inspection, Initial Start-up and Concluding Work	24
Heater Lockout Reset Procedure	25
Electrical Harness Schematic - Part 1	26
Electrical Harness Schematic - Part 2	27
Heater Plumbing Schematic - Inline Method	28



Warning

- *Improper installation or repair of Webasto heating and cooling systems can cause fire or the leakage of deadly carbon monoxide leading to serious injury or death.*
- *Installation and repair of Webasto heating and cooling systems requires special Webasto training, technical information, special tools and special equipment.*
- *NEVER attempt to install or repair a Webasto heating or cooling system unless you have successfully completed the factory training course and have the technical skills, technical information, tools and equipment required to properly complete the necessary procedures.*
- *ALWAYS carefully follow Webasto installation and repair instructions and heed all WARNINGS.*
- *Webasto rejects any liability for problems and damage caused by the system being installed by untrained personnel or by improper installation.*
- *Improper installation or installation by untrained personnel voids all warranties on this product.*

If there are any questions regarding the installation or maintenance of this product, please call technical support at **1-800-555-4518**.

Parts List

Quantity	Part	Part Number
1	Heater Kit	5000515C
1	Installation Kit	5001273A

Vehicle Information

Manufacturer	Model	Year	Engine Type
GMC	Sierra 2500 HD	Beginning Model Year: 2000	6.6 Liter
GMC	Sierra 3500 HD		6.6 Liter
Chevrolet	Silverado 2500 HD		6.6 Liter
Chevrolet	Silverado 3500 HD		6.6 Liter

Foreword

The installation and service of Webasto Thermo Top series (BlueHeat) heaters requires special expertise and training. Installations and servicing of Webasto products by untrained, unauthorized personnel and end-users voids all warranties and releases Webasto Product North America, Inc. and Webasto authorized distributors, dealers and their personnel from responsibility for damage to Webasto products, any resulting collateral property damage and personal injury.

Any use, operation, installation, modification or application of the product not described in Webasto manuals, or subjecting the product to extreme or unusual conditions beyond the limits of specified performance characteristics is misuse of the product.

Failure to comply with all installation instructions is a misuse of Webasto products. The same applies for repairs without using genuine Webasto service parts. This will void the coolant heaters "official Marks of Conformity."

Scope and Purpose

These installation instructions are intended to support Webasto trained and authorized distributors and dealers in the installation of the Thermo Top series (BlueHeat) Coolant Heaters. These instructions are not intended for use by untrained or unauthorized personnel.

The directives in the "installation manual" and "operating manual" for the Thermo Top series heater must be followed. Acknowledged engineering conventions must be observed for the installation work.

ATTENTION

All relevant state and provincial licensing regulations if any, governing the installation and use of auxiliary heating devices must be observed!



CAUTION

Location of heater, installation of coolant lines, fuel system and components, wiring and control devices are important for proper operation. Failure to comply with the installation instructions provided may result in poor operation or damage to heater and vehicle components.



Symbol Identification

Symbols that define sections in manual

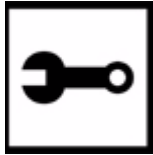

Mechanical Preparation



Fuel



Electrical



Exhaust



Coolant



Combustion Air Intake

General Symbol Descriptions



Warning



Refer to Webasto or Manufacturer Manual



Caution



Attention



Flammable or Combustible

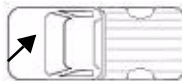

Line of Sight/Item Location on Vehicle

General References

- Bare body parts, for example around drilled holes, must be treated with anti-corrosive coating.
- Secure hoses, cables and wiring harnesses with cable ties and fit protective hoses around them at chafing points.
- Fit edge protectors (opened fuel hose) to sharp edges.

Preparation

Heater Kit

- Verify and identify all contents of kit.

Vehicle

- Verify fuel content in tank.

CAUTION

For reasons of safety due to the weight of fuel and the tank, it is recommended that there be no more than 1/4 tank of fuel present. If fuel quantity is greater than 1/4 of capacity, make provisions to reduce quantity of fuel or consider removal of pick-up box to gain access to fuel sender location if feasible.

- Disconnect negative terminal of vehicle battery(s).
- Remove air cleaner, air cleaner housing and air cleaner mounting tray. Refer to vehicle manufacturers instructions.
- Remove instrument panel fascia for timer mounting. Refer to vehicle manufacturers instructions for fascia removal.
- Protect vehicle fenders, panels and interior with covers

Heater Installation Site

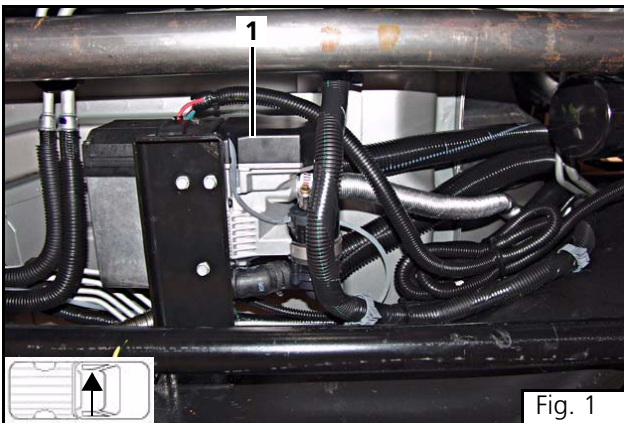

Mount the Webasto auxiliary heater on the left framerrail just below the drivers compartment.

- (1) Webasto Auxiliary Coolant Heater (Installed)





Electrical - Overview



ATTENTION

The routing of cables and wires are done in accordance to the general valid rules of engineering. If not described differently, securing of wiring and cables is done with cable ties to the vehicle's own wires and cable harnesses.



ATTENTION

Timer control location is a recommendation only. Please consult with the customer before mounting.

HVAC Blower Motor

(1) Blower relay K3

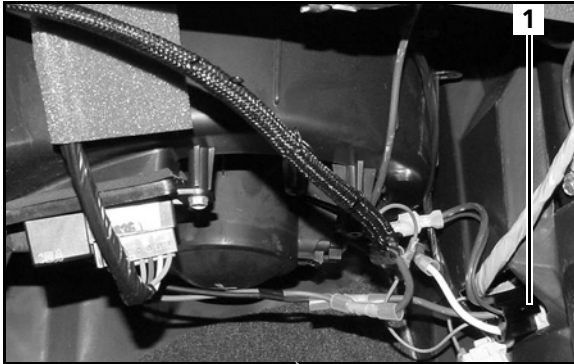

Timer Control

(1) Timer

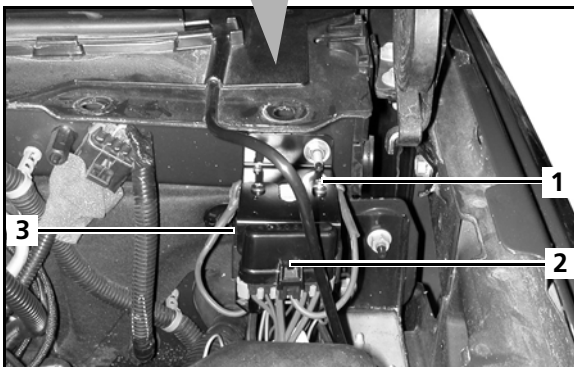
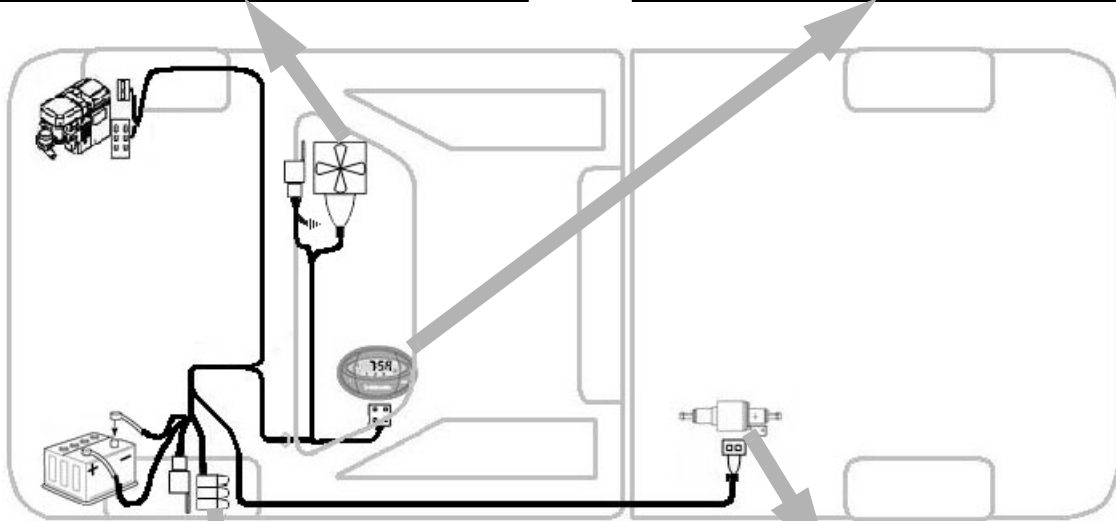

Fuse Block/Relays/Resistor

- (1) Mounting Bracket
- (2) Fuse Holder
- (3) Relays K1 & K2 (back of bracket)

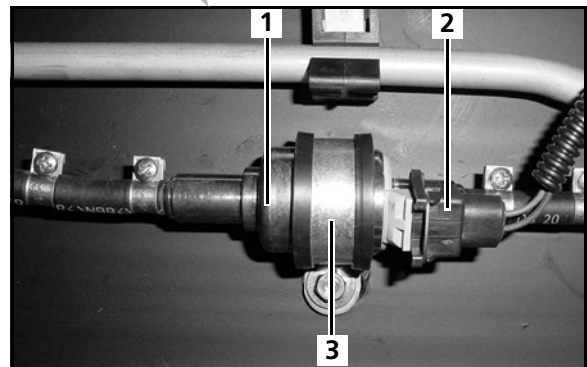

Fuel Metering Pump

- (1) Pump
- (2) Connector
- (3) Mount Strap

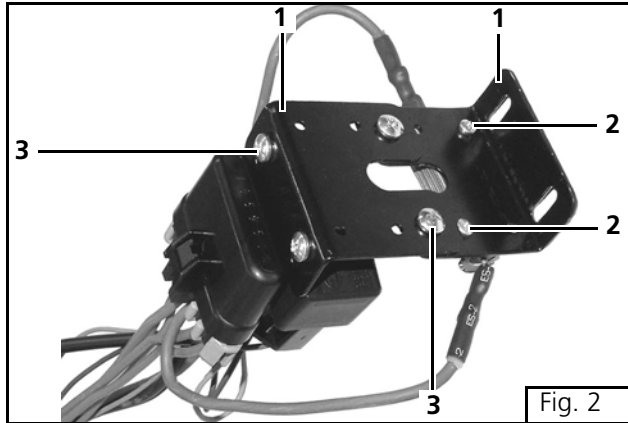

Electrical Harness

ATTENTION

Cut wire tie holding negative-side blower harness (with relay) from main harness and set aside.

To attach fuse holder to bracket, a 6.0 mm (1/4 in.) can be drilled through the bracket. Attach fuse holder with plastic anchor included. Assemble as shown.

- (1) Mounting Bracket (2 required)
- (2) Screw M3x10, Nut M3
- (3) Pan Head Screw 10-32x5/8", Nut 10-32

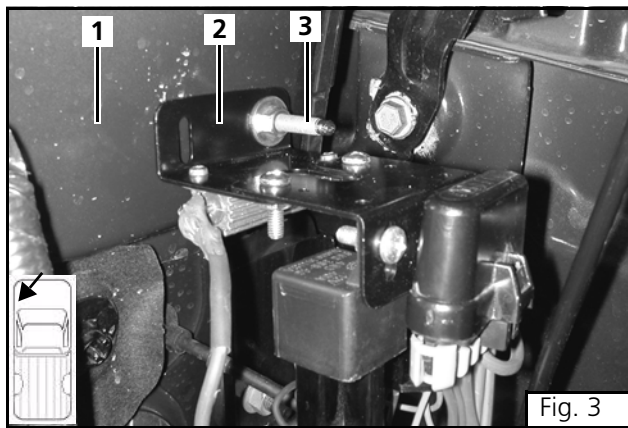

Secure the electrical mounting bracket assembly to the left corner of the bulkhead using an existing stud and nut provided in kit.

- (1) Vehicle bulkhead - left corner
- (2) Electrical mounting bracket assembly
- (3) Existing vehicle stud and nut

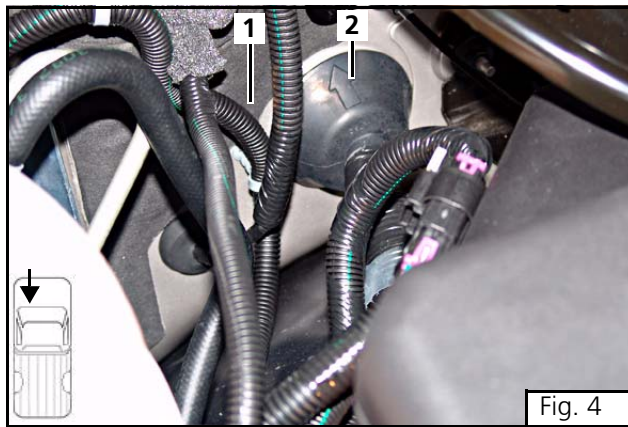

CAUTION

Use care when cutting bulkhead grommet to prevent damage to vehicle electrical harnesses.

Cut a 12.7 mm (.5 inch) slit in the bulkhead pass-through grommet.

Route the timer and blower control harnesses into the interior of the vehicle through the bulkhead grommet.

- (1) Vehicle bulkhead
- (2) Bulkhead grommet

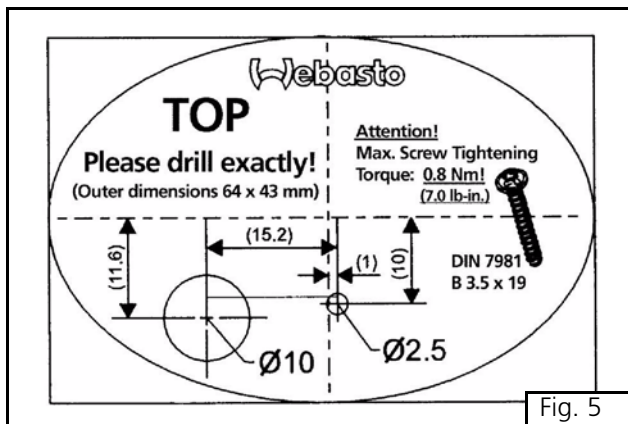

Timer Installation

CAUTION

Check behind panels for obstructions before drilling holes.

ATTENTION

Before installing the timer, please confirm the installation location with the customer.

Affix supplied template to panel. Drill 10 mm (25/64 in.) and 2.5 mm (3/32 in.) holes where indicated on template. Figure 5 shows a translated sample of the template supplied.





ATTENTION

Before installing the timer, please confirm the installation location with the customer.

- (1) Timer - Sample location only

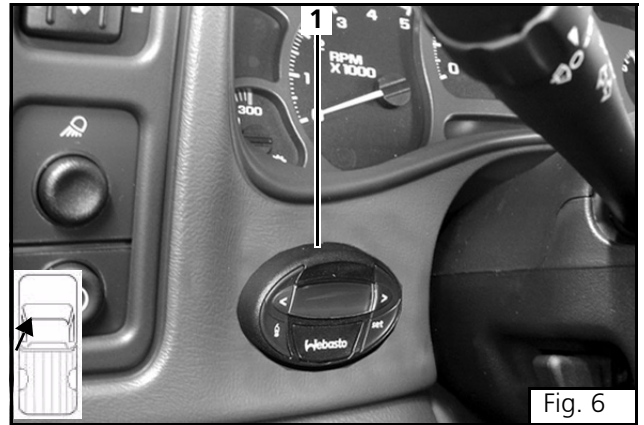

Fig. 6

Fuse Tap Connection - Relay K-1

Locate a fuse (15 to 20 amp) in the underhood fuse / relay center that is "HOT" when the ignition is in the ON position only.

Route blue fuse tap wire from relay K-1, up into the under hood fuse panel.

- (1) Fuse tap wire
- (2) Fuse tap

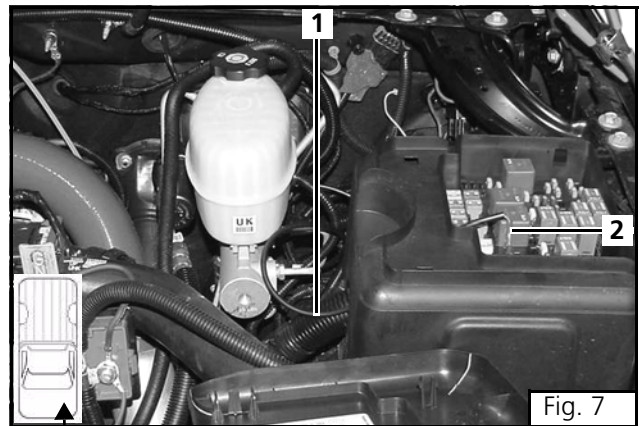

Fig. 7



CAUTION

Tap into the "fused" output side of the selected fuse.

- (1) Fuse tap - close up

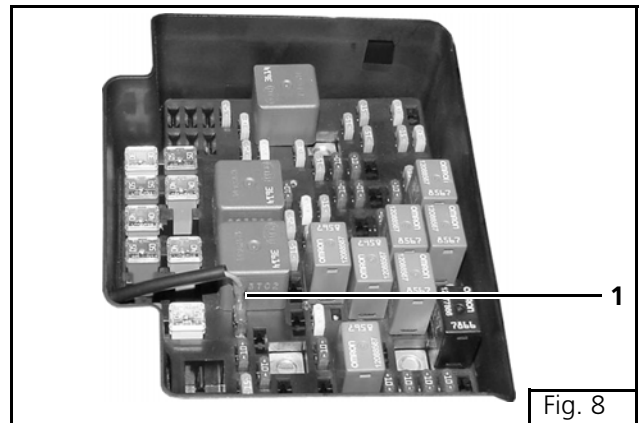

Fig. 8

Integration into the Blower System

Remove panel to access blower area.
Route Blower harness over to blower area.
Mount negative-side blower harness and relay in vicinity of HVAC blower.
Wire according to schematic in Figure 10.

- (1) Positive-side blower integration harness
- (2) Ground point (see item 1, Figure 10)
- (3) Relay K-3 of negative-side harness
- (4) HVAC blower motor

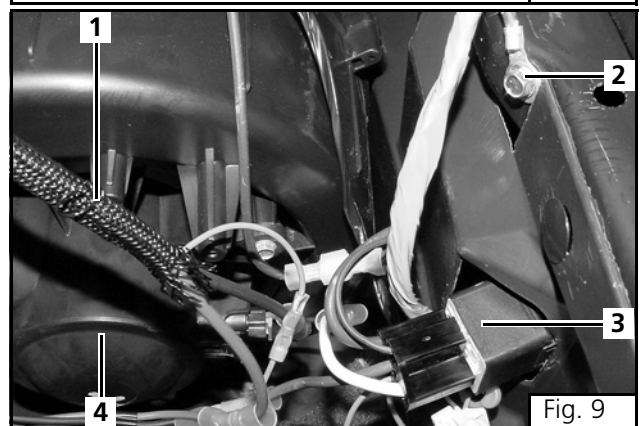

Fig. 9

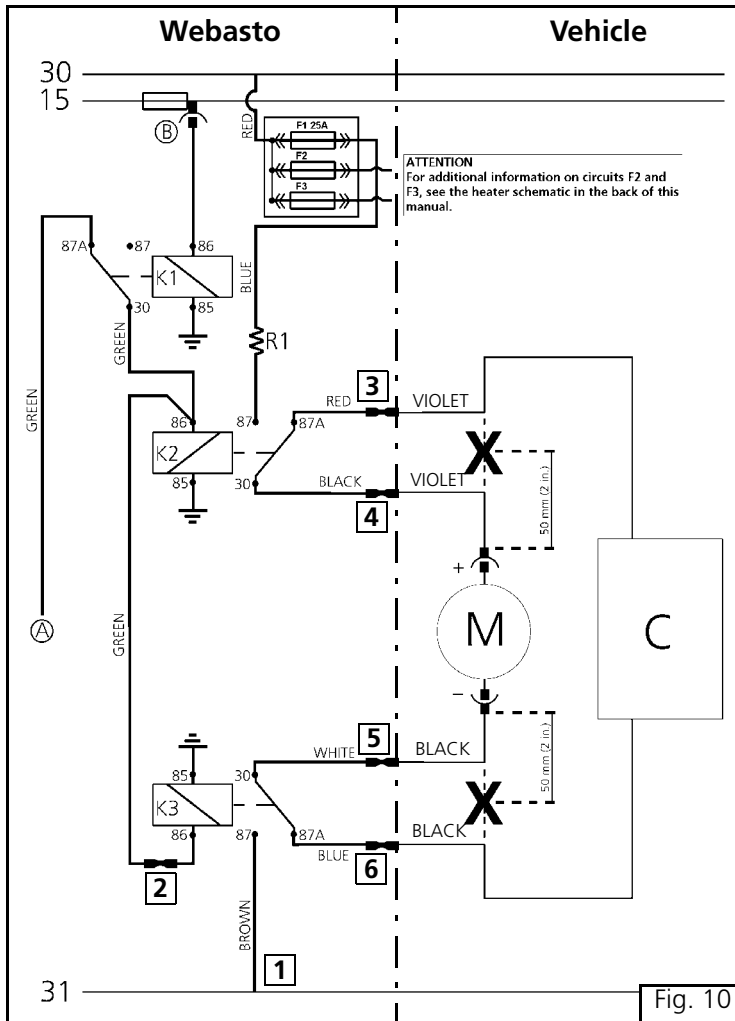

Fig. 10

3-Relay HVAC Harness Connections

NOTE:

It is permissible to cut excess length from Webasto HVAC wiring harnesses to fit the application.

Cut motor wires where indicated by "X"

- (1) Chassis ground
- (2) Splice green wire to green wire
- (3) Strip and crimp red to controller side violet wire
- (4) Strip and crimp black to motor side violet wire
- (5) Strip and crimp white to motor side black wire
- (6) Strip and crimp blue to controller side black wire

CAUTION

Check your wiring! Ensure that all connections have been done in accordance with the wiring diagram shown (Fig. 10). Sensitive electronic controls can be damaged if wired incorrectly!



Secure HVAC blower control wiring to vehicle structures with nylon wire ties. (Image not available)

NOTE:

Complete heater harness schematics are included on page 27 and 28 of this manual.

Legend for Figure 10

- A From Webasto Heater X1
- B 12 VDC Ignition 'On' Fuse Tap
- C HVAC Control Module
- M HVAC Blower Motor
- X Cut wire at 50 mm (2 in.) from motor
- F1 Fuse - Blower Circuit 25 Amp.
- K1 Relay - Ignition 'On' Interrupt
- K2 Relay - Positive Side of Blower Motor Circuit
- K3 Relay - Negative Side of Blower Motor Circuit
- R1 Resistor - Blower Speed Control
- 30 Battery Positive (Constant Power)
- 15 Ignition (Switched Power)
- 31 Battery Negative (Chassis Ground)



Heater Control Harness Routing



CAUTION

Secure heater control harness away from hot exhaust components and moving vehicle components with cable ties.

Route heater control harness from the engine compartment to the left framerail. Keep heater harness away from the exhaust system and the steering shaft.

- (1) Heater control harness
- (2) Brake fluid reservoir

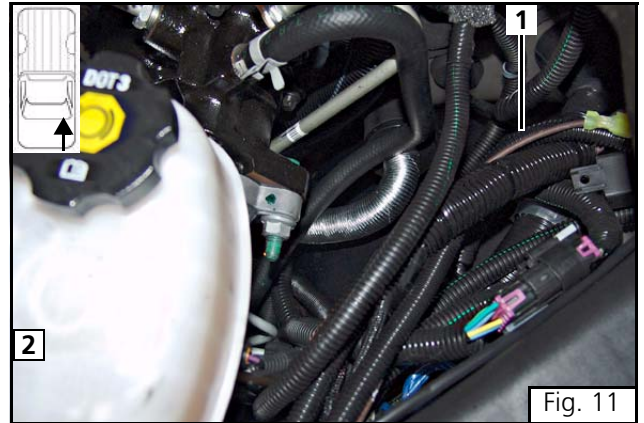

Bundle excess heater harness and secure to left framerail with cable ties.

- (1) Heater control harness
- (2) Left framerail

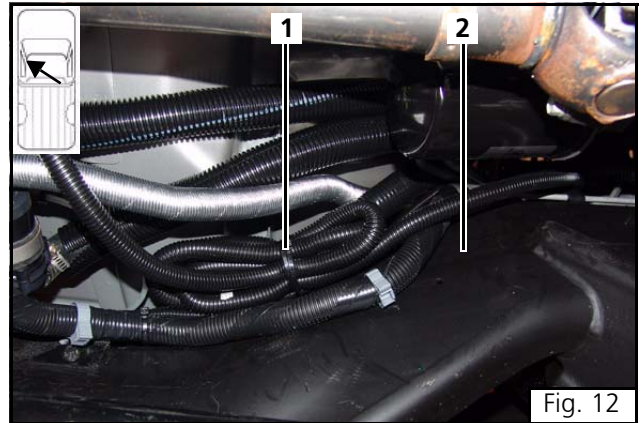

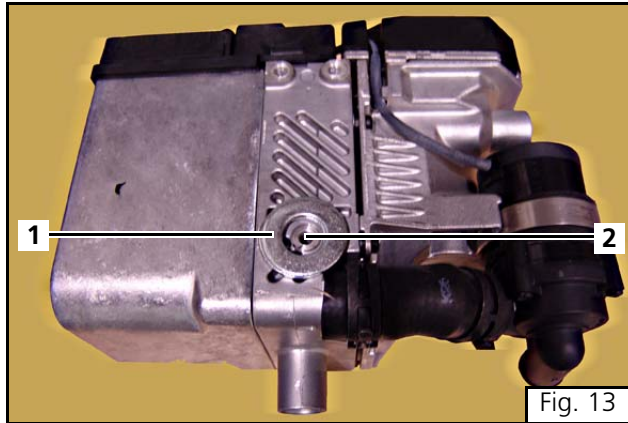

Fig. 13

Heater Preparation

ATTENTION

Before installing the heater on the bracket look to see if the bracket has a raised area around the lower heater mounting hole. If the bracket is flat, position two spacer washers between the mounting bracket and the heater before installing the lower EJOT screw.

- (1) Spacer washers
- (2) Lower mounting hole

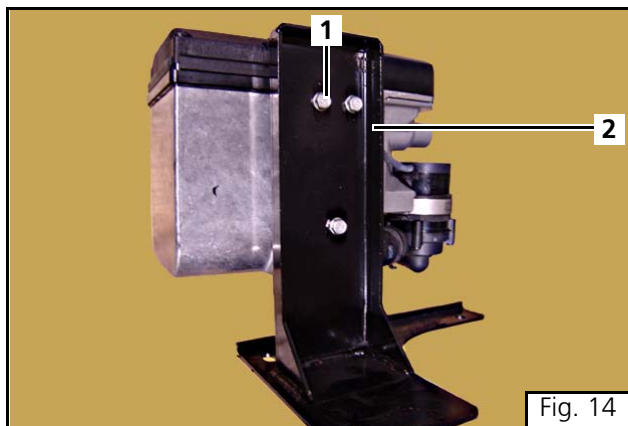

Fig. 14

ATTENTION

Observe torque specifications.

Install the heater on the mounting bracket as shown in Figure 14.

- (1) M6 EJOT screw x3. Torque 10 Nm (88.5 lb-in.)
- (2) Heater mounting bracket

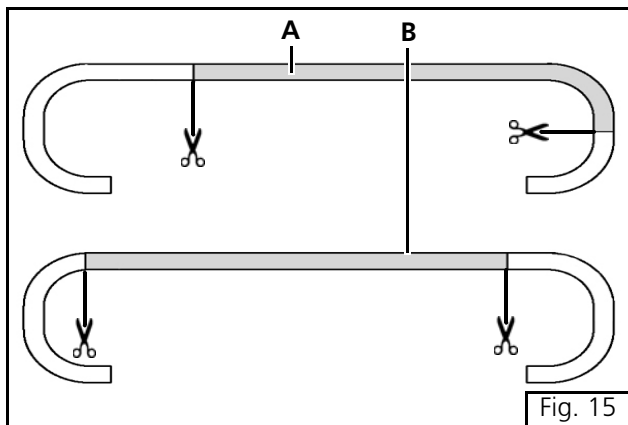

Fig. 15

Cut supplied hoses as shown in Figure 15.

Hose A: From engine to coolant pump inlet = 175 cm (69 inches).

Hose B: From Webasto heater outlet to vehicle heater core inlet = 185 cm (73 inches).

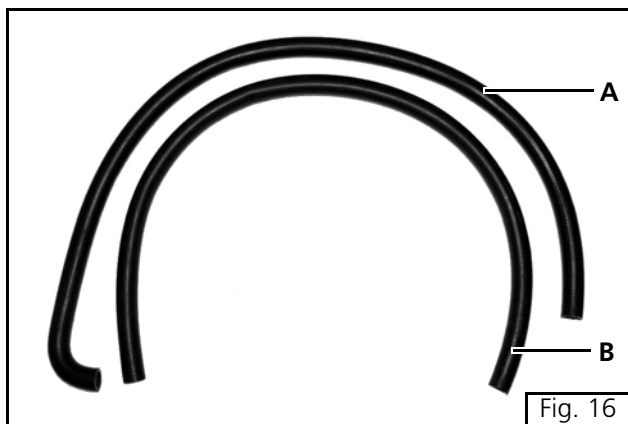

Fig. 16

- (A) Heater inlet (supply) hose with 90 degree turn
- (B) Heater outlet (return) hose



GMC Sierra / Chevrolet Silverado 2500 HD & 3500 HD



ATTENTION

Observe torque specifications.

Connect coolant hoses and fuel line coupler to heater as shown in Figure 17.

- (1) Heater inlet "A" hose with 90 degree turn
- (2) Heater outlet "B" hose
- (3) Fuel line coupler
- (4) Hose clamp - Torque 1.0 - 1.4 Nm (8.8 - 12.4 lb-in.)
- (5) Hose clamp - Torque 2.0 - 2.5 Nm (18 - 22 lb-in.)

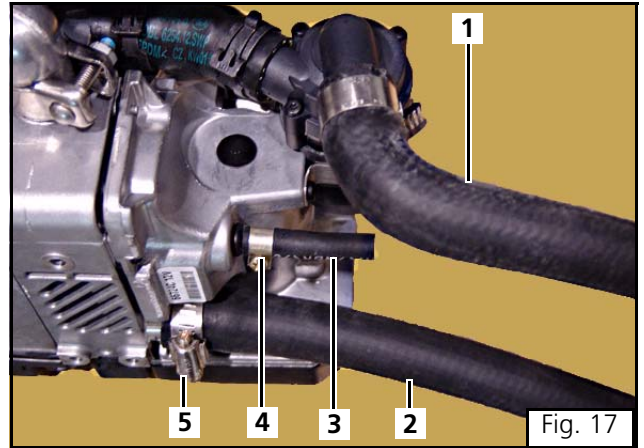

Fig. 17

Install exhaust tube on heater with 90° elbow.

- (1) Exhaust tube
- (2) Exhaust clamp x2. - Torque 5 - 5.5 Nm (44 - 49 lb-in.)
- (3) Exhaust elbow

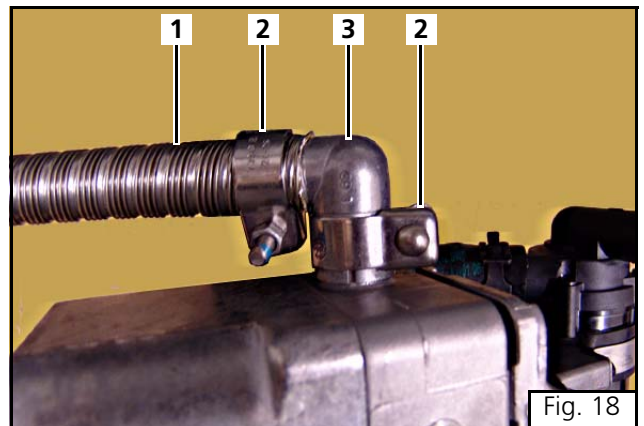

Fig. 18

Heater Installation Site Preparation

ATTENTION

Pull harness clip from existing hole in framerail. This hole will be used to mount the heater. Secure the harness to vehicle with cable ties after mounting the heater.

- (1) Existing holes in left framerail
- (2) Vehicle harness clip

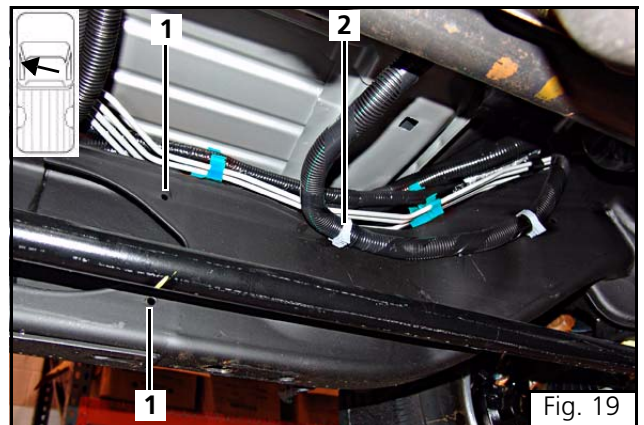

Fig. 19

Connect the heater harness to the heater before installing the heater on the framerail.

- (1) Heater harness

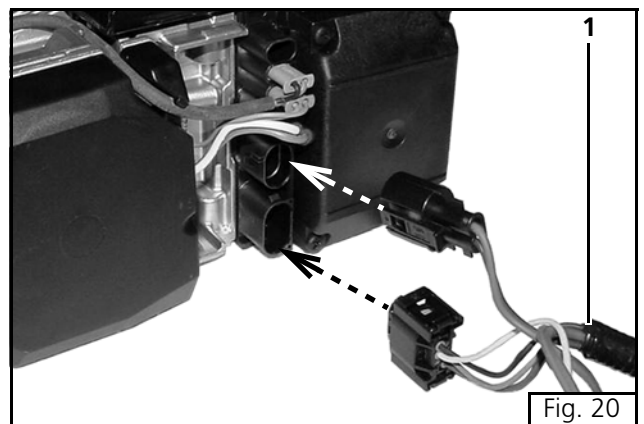
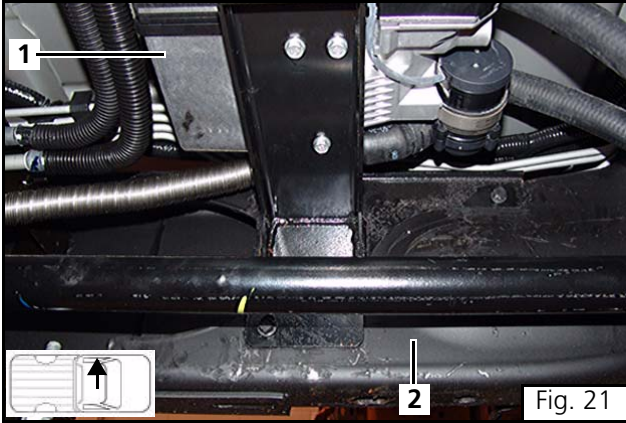

Fig. 20





Heater Installation

Mount the heater and mounting bracket assembly on the left framerail with 3 screws provided.

- (1) Heater and mounting bracket assembly
- (2) Left framerail

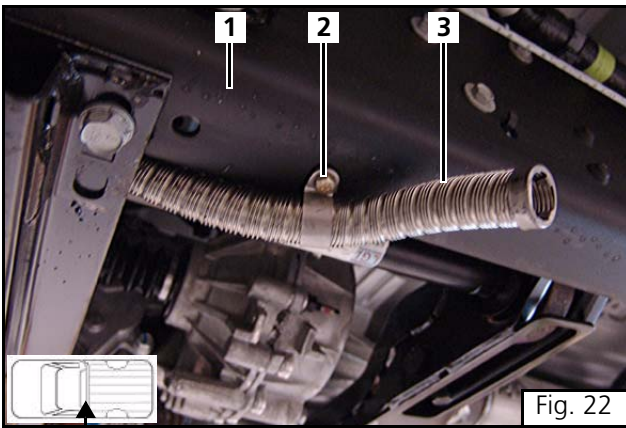

Exhaust Installation

ATTENTION

Ensure outlet end of exhaust tube is directed downward and slightly rearward 10 degrees.

Secure the exhaust tube using an existing hole in the left framerail and p-clamp provided.

- (1) Left framerail
- (2) P-clamp, M6 bolt and nut
- (3) Exhaust tube

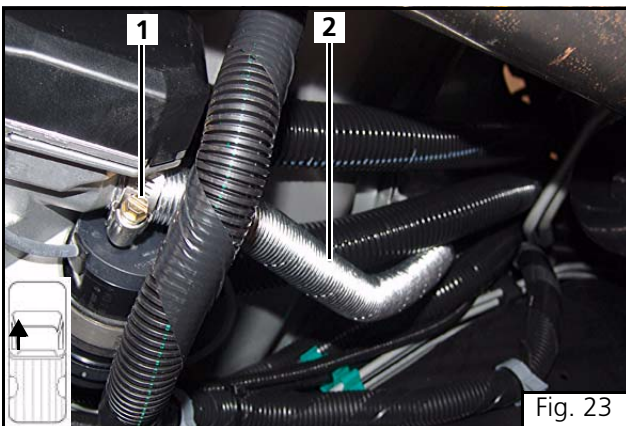

Combustion Air Intake Installation

ATTENTION

Observe torque specifications.

Attach combustion air intake tube with silencer to heater. The combustion air intake port is located directly above the coolant pump

- (1) #10 Clamp. Torque 2.0 - 2.5 Nm (18 - 22 lb-in.)
- (2) Combustion air tube

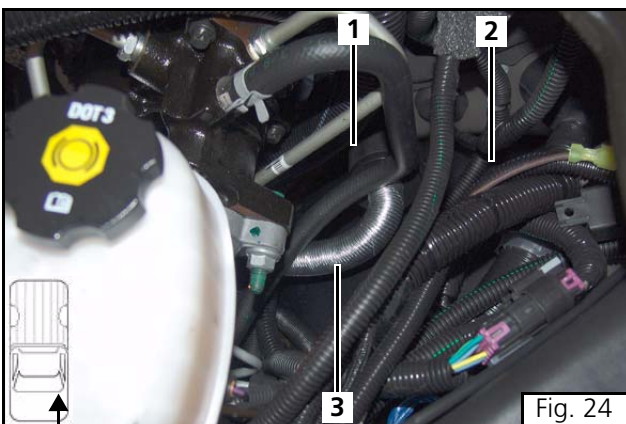

Route the combustion air intake tube into the left inner fender area.

Bend the combustion air intake down so that the silencer is pointing downward and secure to vehicle using cable ties.

- (1) Air intake silencer
- (2) Left inner fender area
- (3) Combustion air intake tube



Integration into the Coolant System



ATTENTION

Torque hose clamps to 2.0 - 2.5 Nm (18 - 22 lb-in.)

Avoid sharp bends and kinks when installing coolant hoses.

Position hose clamps in such a way to avoid cutting or damaging adjacent components.



ATTENTION

Clamp vehicle coolant hose with hose clamping pliers prior to cutting to prevent coolant spillage.

The coolant heater integration into the vehicle heater circuit is done in an "INLINE" fashion. Refer to Figure 25.

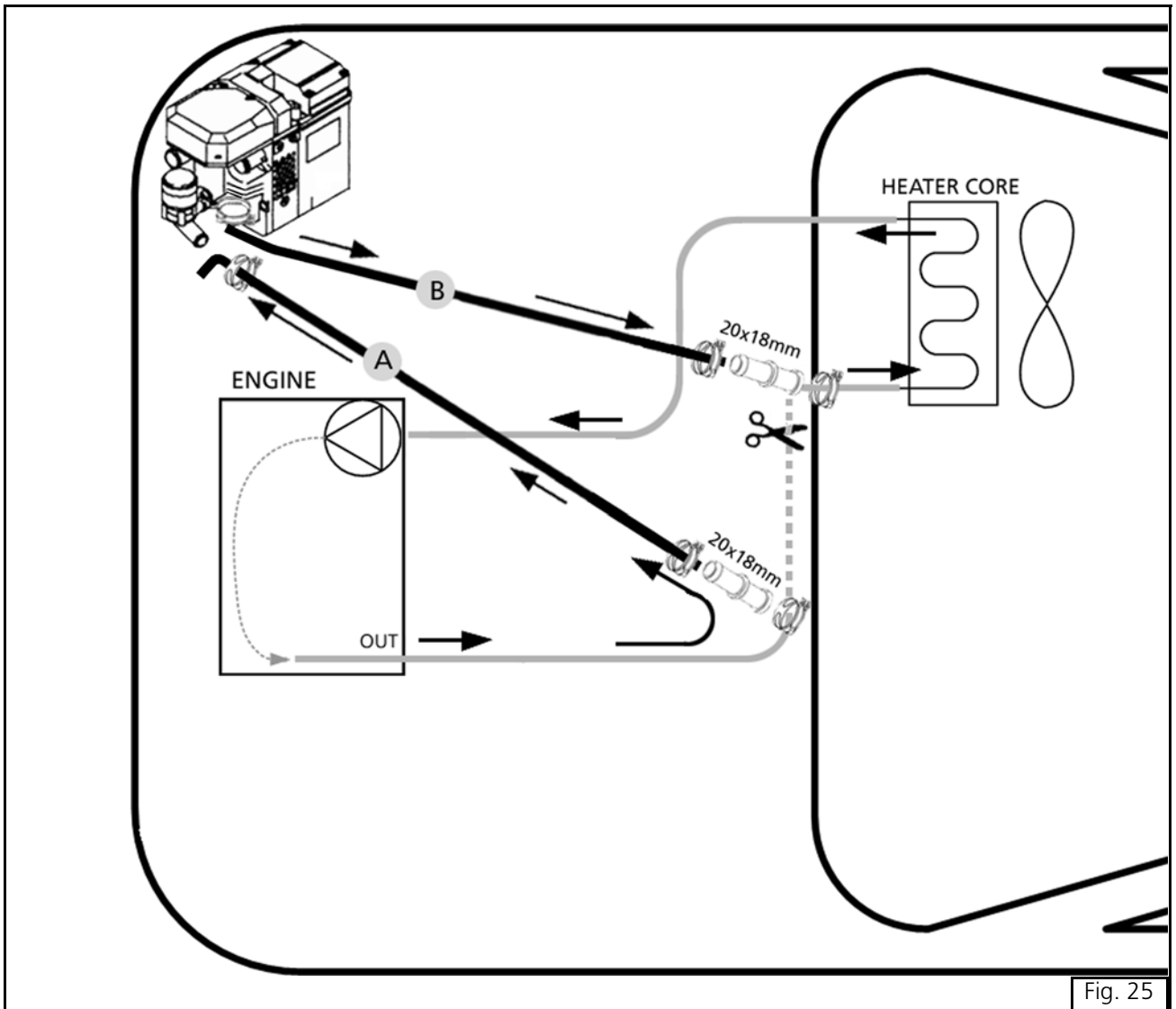

Coolant flow and connection detail:

Hose A: From engine to Webasto coolant pump inlet.

Hose B: From Webasto heater outlet to vehicle heater core inlet.

NOTE:

Also see the plumbing schematic, page 31, of this manual for a general outline of the coolant circuit arrangement.

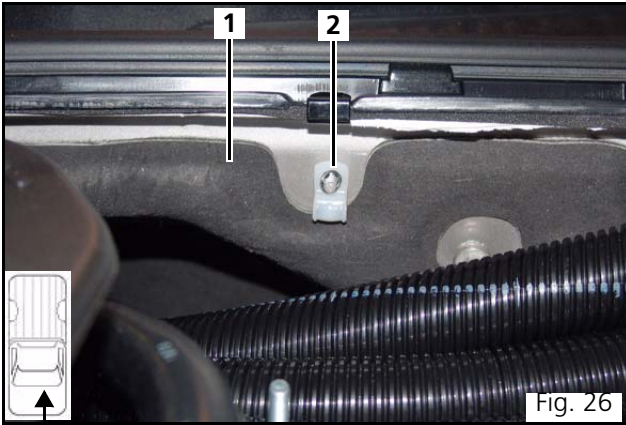

Coolant Hose Routing

Install a p-clip on the bulkhead using an existing stud and pushnut provided. The p-clip will be used to secure the heater coolant hoses to the bulkhead.

- (1) Vehicle bulkhead
- (2) P-clip and pushnut

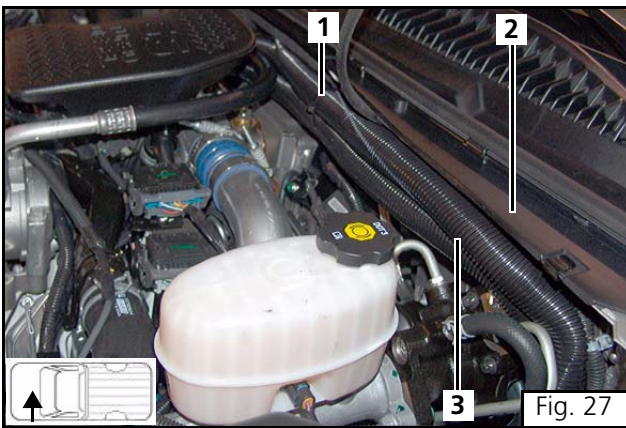

CAUTION

Avoid sharp bends and kinks when installing coolant hoses. Keep coolant hoses away from vehicle exhaust system and moving components.

Route the heater coolant hoses from under the vehicle to the engine compartment. Continue routing the coolant hoses toward the heater core, along the bulkhead, as shown in Figure 27.

Secure the coolant hoses with cable ties to existing vehicle components and to the p-clip installed previously.

- (1) Cable tie
- (2) Vehicle bulkhead
- (3) Heater coolant hoses

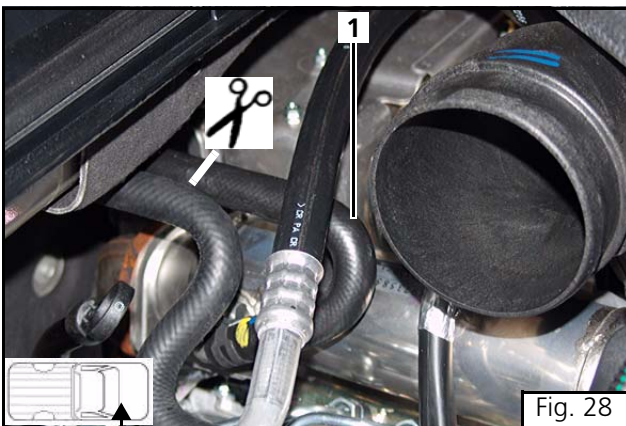

ATTENTION

Confirm supply and return lines to vehicle heater core before cutting any coolant lines. Once confirmed, cut supply hose at point close to heater core leaving sufficient hose for connections.

Use hose clamping pliers to prevent coolant loss.

- (1) Heater core supply hose

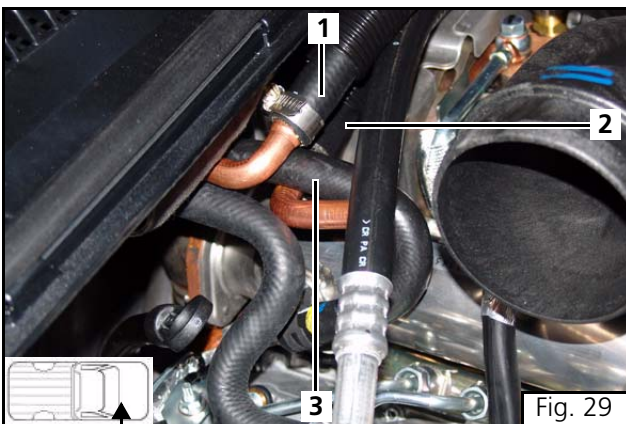

ATTENTION

Position hose clamps in such a way to avoid cutting or damaging adjacent components.

Torque hose clamps to 2.0 - 2.5 Nm (18 - 22 lb-in.).

Connect heater hoses coming from the Webasto heater to heater hose selected in the previous step using the 90° brass coolant adapters provided.

- (1) Webasto coolant hose returning from heater outlet to vehicle heater core inlet (hose "B")
- (2) Webasto coolant hose leading from engine to heater circulation pump inlet (hose "A")
- (3) Heater core supply hose





Integration into the Fuel System

Fuel Pump Installation

The fuel pump is mounted horizontally along the left inside framerail, ahead of the fuel cooler, using an existing hole in the frame. See Figures 30 and 32.

- (1) P-clip
- (2) Vehicle framerail
- (3) M6 Fender washer
- (4) Capscrew
- (5) M6 flanged nut

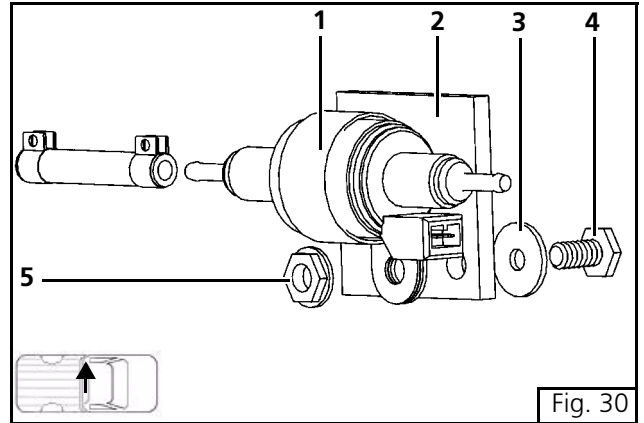

Fig. 30



ATTENTION

Ensure the fuel lines are fully seated within the fuel line couplers and any 90 degree bends are not buckled. Refer to Figure 31.

Tighten all fuel line clamps to 1.0 - 1.4 Nm (8.8 - 12.4 lb.-in.)

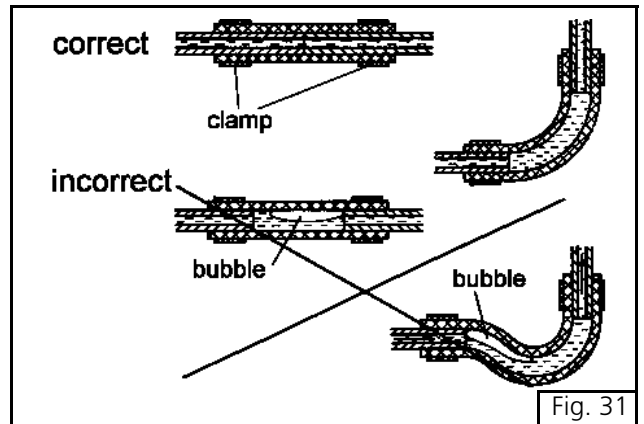

Fig. 31

Fuel Line Routing - Fuel Pump to Heater

Connect mecanyl fuel line to the outlet side of the fuel pump with fuel line coupler.

- (1) Fuel pump - installed
- (2) Fuel line clamp
- (3) Mecanyl fuel line
- (4) Fuel line coupler

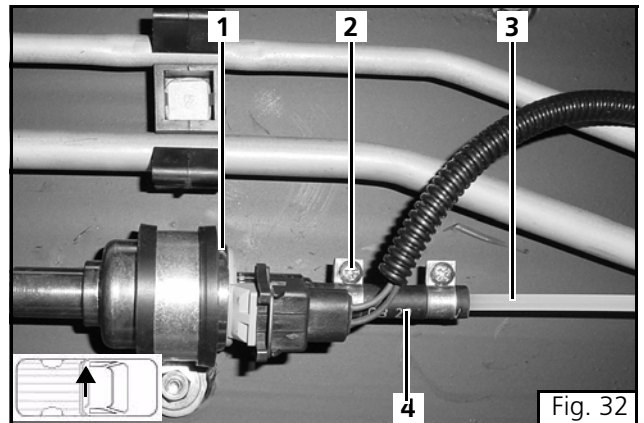

Fig. 32

Route the fuel line from the fuel pump along the left frame rail to heater mounting location. Use the existing vehicle fuel line clips to secure the heater fuel line to the vehicle.

- (1) Existing vehicle fuel line clip
- (2) Mecanyl fuel line
- (3) Left framerail
- (4) Webasto heater location

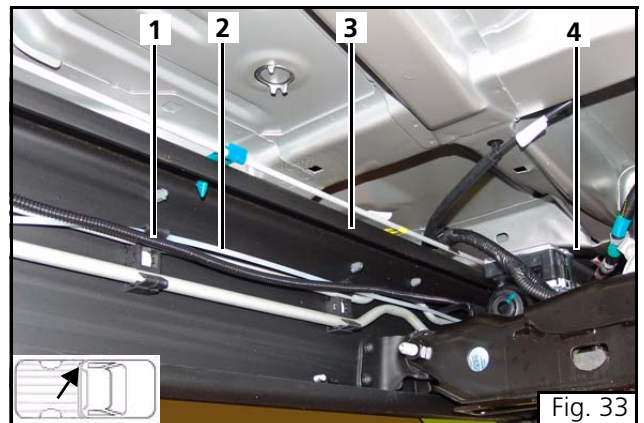

Fig. 33

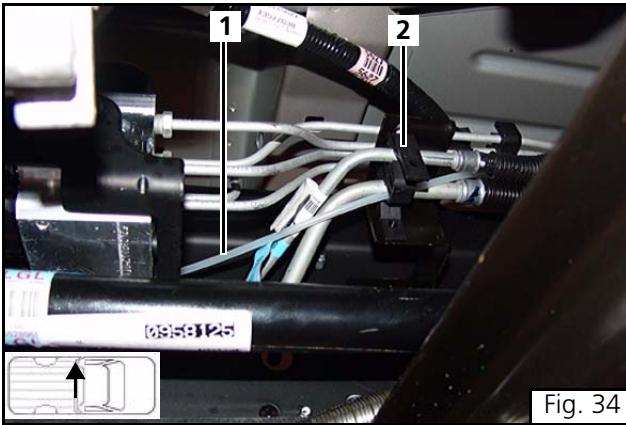

Fig. 34

Continue routing the mecanyl fuel line toward the heater. Use existing vehicle clips and cable ties to secure the fuel line to the vehicle.

- (1) Mecanyl fuel line (heater)
- (2) Existing fuel line clip
- (3) Fuel line clamp - Torque 1.0 - 1.4 Nm (8.8 - 12.4 lb-in.)



Fig. 35

ATTENTION

Always cut Mecanyl fuel line with a sharp razor knife or razor edged cutter. Using side cutters, scissors or similar tools will cause a restriction inside the fuel line

Cut fuel line to length and connect to the fuel line coupler previously installed.

- (1) Mecanyl fuel line (heater)
- (2) Fuel line coupler
- (3) Fuel line clamp - Torque 1.0 - 1.4 Nm (8.8 - 12.4 lb-in.)

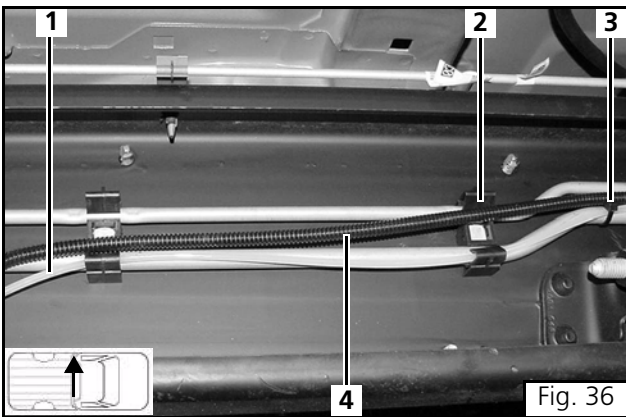

Fig. 36

Fuel Pump Harness Routing

Route the fuel pump harness along side the heater harness from the engine compartment to the left framerail.

Route the fuel pump harness down the left framerail to the fuel pump mounting location following the heater fuel line. Secure the fuel pump harness to the vehicle with cable ties.

- (1) Mecanyl fuel line (heater)
- (2) Existing vehicle fuel line clip
- (3) Nylon cable tie
- (4) Electrical harness - fuel pump

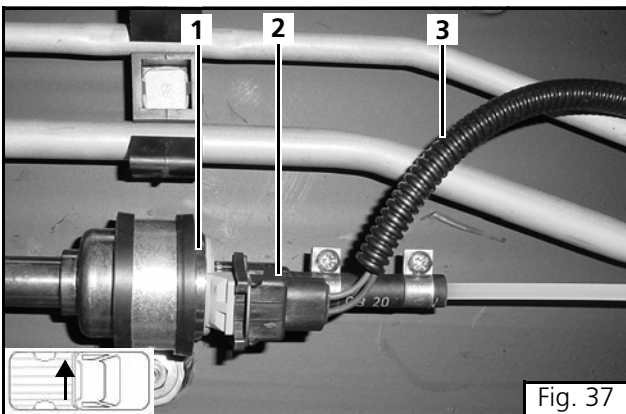

Fig. 37

Assemble electrical harness connector and connect harness to pump.

- (1) Heater fuel pump
- (2) Fuel pump electrical harness connector
- (3) Fuel pump electrical harness



Standpipe Installation - 2000 Through 2003 Model Years



CAUTION

For reasons of safety due to the weight of fuel and the tank, it is recommended that there be no more than 1/4 tank fuel present. If fuel quantity is greater than 1/4 of capacity, make provisions to reduce quantity of fuel or consider removal of pick-up box to gain access to fuel sender location if feasible.



ATTENTION

Using an appropriate jack and safety stands, lower the fuel tank and remove the fuel sender unit according to the vehicle manufacturers servicing instructions.



- (1) Drill hole 8.0 mm (5/16 in.)



ATTENTION

De-burr both sides of hole after drilling.

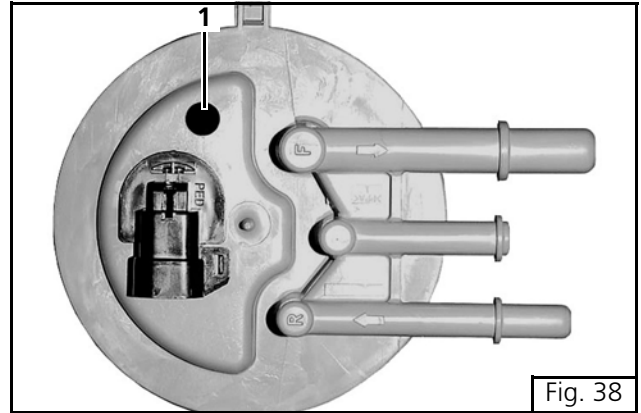

Fig. 38

Cut standpipe to length. The standpipe tube should terminate approximately 38 mm (1.5 in.) off bottom of tank when installed.

Bend standpipe as shown.



ATTENTION

Ensure standpipe does not interfere with the float arm assembly.

Install standpipe, see inset image for item sequence.

- (2) Fuel sender unit
- (3) Standpipe
- (4) Nylon cable tie

Legend for Inset Image

- 1 Banjo Bolt - Torque 8.5-9.5 Nm (75-84 lb-in.)
- 2 Banjo Fitting
- 3 Standpipe
- 4 Upper Sealing Washer (Black)
- 5 Fuel Tank
- 6 Lower Sealing Washer (Brass)
- 7 Lock Nut - Torque 8.5-9.5 Nm (75-84 lb-in.)

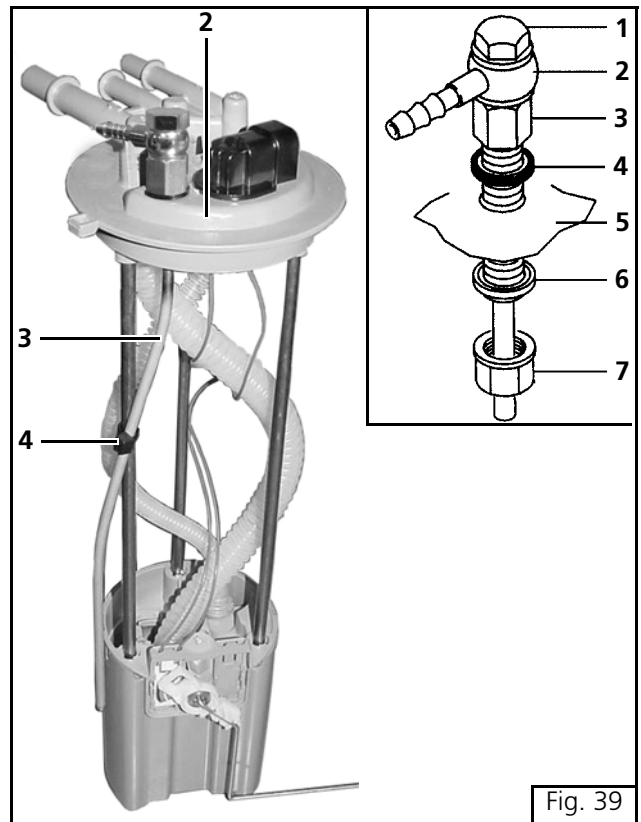
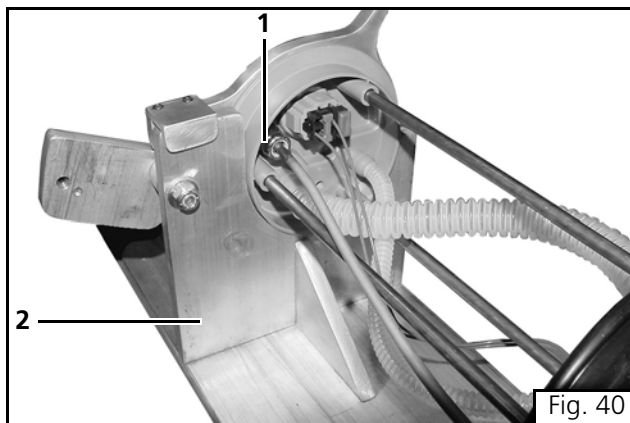

Fig. 39

GMC Sierra / Chevrolet Silverado 2500 HD & 3500 HD



– (1) M8 locking nut
Torque to 8.5-9.5 Nm (75-84 lb-in.)

– (2) Holding fixture (not required)

Re-install fuel sender assembly according to the vehicle manufacturers servicing instructions.

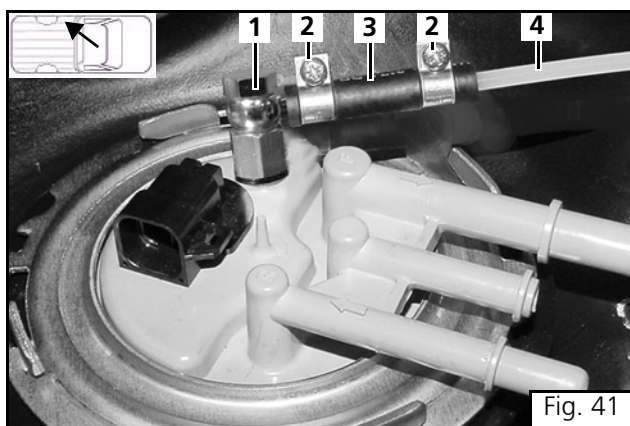

Connect fuel line to fuel sender. Route fuel line forward along existing vehicle fuel lines. Install fuel tank according to vehicle manufacturers servicing instructions.

– (1) Fuel standpipe
– (2) Fuel line clamps
Torque 1.0-1.4 Nm (8.8-12.4 lb-in.)

– (3) Fuel line coupler
– (4) Mecanyl fuel line

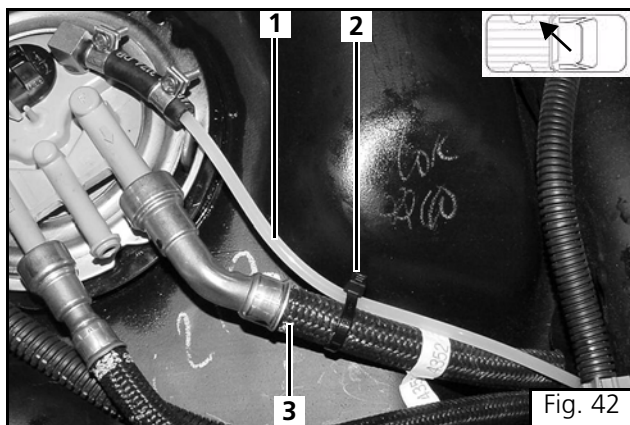

Route Mecanyl fuel line along existing vehicle fuel lines as shown. Secure fuel line to existing vehicle fuel lines with nylon cable ties as shown.

– (1) Mecanyl fuel line
– (2) Nylon cable tie
– (3) Existing vehicle fuel lines

Proceed to page 22 for fuel line routing and connection to fuel pump beginning at Figure 52.



Standpipe Installation - 2004 - 2006 Model Year



CAUTION

For reasons of safety due to the weight of fuel and the tank, it is recommended that there be no more than 1/4 tank fuel present. If fuel quantity is greater than 1/4 of capacity, make provisions to reduce quantity of fuel or consider removal of pick-up box to gain access to fuel sender location if feasible.



ATTENTION

Using an appropriate jack and safety stands, lower the fuel tank and remove the fuel sender unit according to the vehicle manufacturers servicing instructions.

A drilling template is provided on last page of this manual. Carefully cut out the template and place on sender unit as shown.

Drill a 1/8 in. pilot hole through the sender where indicated. The pilot hole must be centered within the surrounding plastic material when viewed from underside. See Figure 45 before drilling.

- (1) Drilling template

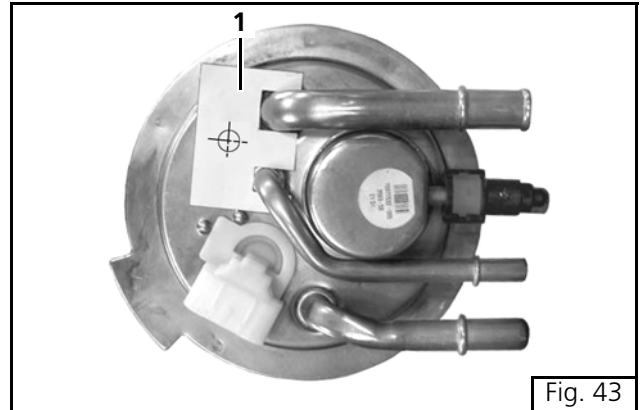

Fig. 43

- (1) Enlarge hole to 8.0 mm (5/16 in.)



ATTENTION

De-burr both sides of hole after drilling.

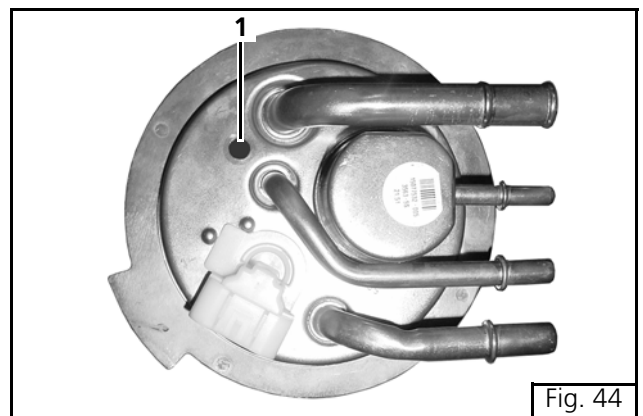

Fig. 44

- (1) Hole viewed from underside



ATTENTION

Note that hole is centered within the surrounding plastic material.

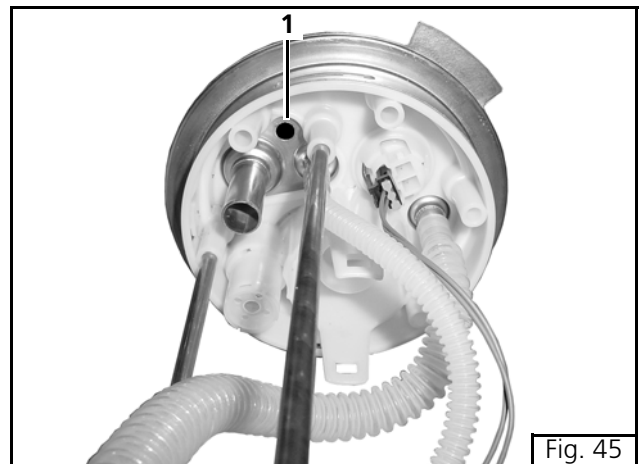
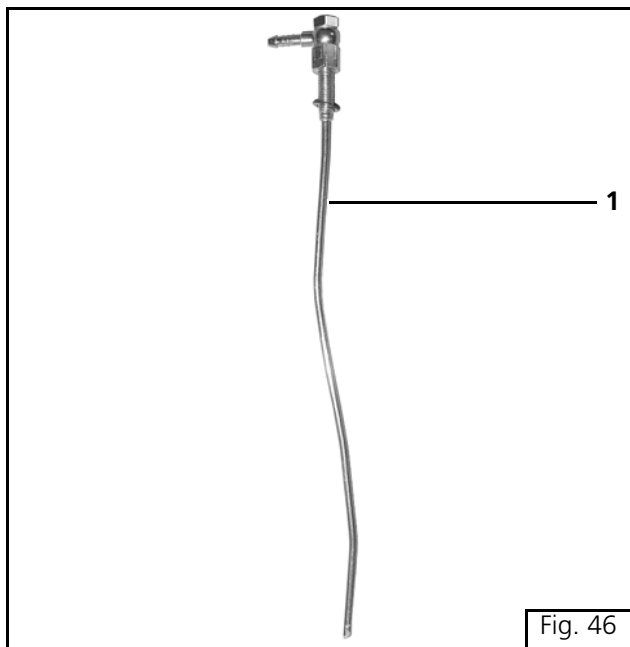
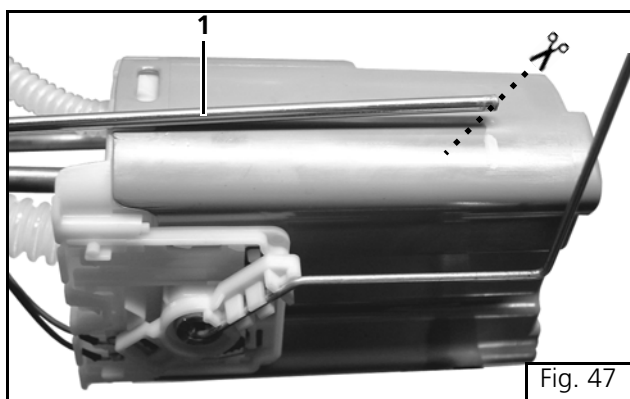

Fig. 45



Cut standpipe to length. The standpipe tube should terminate approximately 38 mm (1.5 in.) off bottom of tank when installed. Refer to Figure 47 for length. Remove any burrs from inside cut end of tube. Bend standpipe as shown.

- (1) Standpipe



The standpipe tube should terminate approximately 38 mm (1.5 in.) off bottom of tank when installed. Refer to Figure 47 for length.

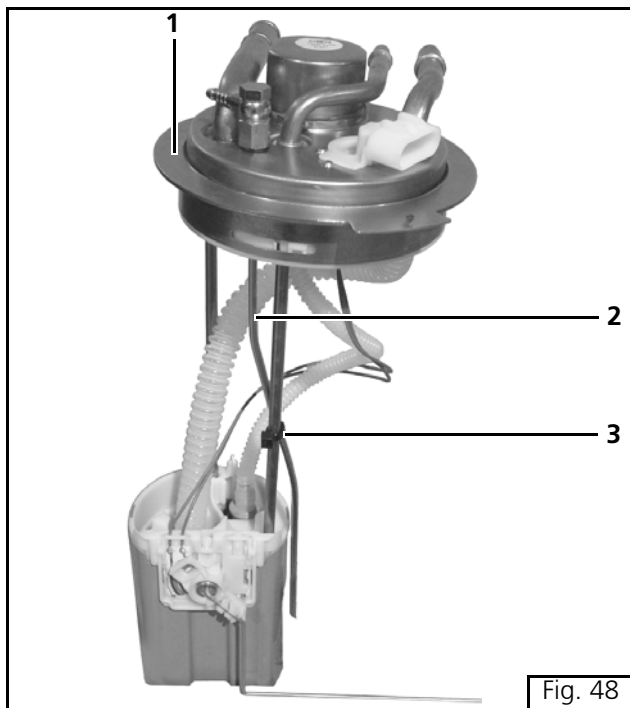

ATTENTION

Ensure standpipe does not interfere with the float arm assembly.

Install standpipe, see Figure 49 for item sequence.

- (1) Fuel sender unit
- (2) Standpipe
- (3) Nylon cable tie





Legend for Figure 49

- 1 Banjo Bolt - Torque 8.5-9.5 Nm (75-84 lb-in.)
- 2 Banjo Fitting
- 3 Standpipe
- 4 Upper Sealing Washer (Black)
- 5 Fuel Tank
- 6 Lower Sealing Washer (Brass)
- 7 Lock Nut - Torque 8.5-9.5 Nm (75-84 lb-in.)

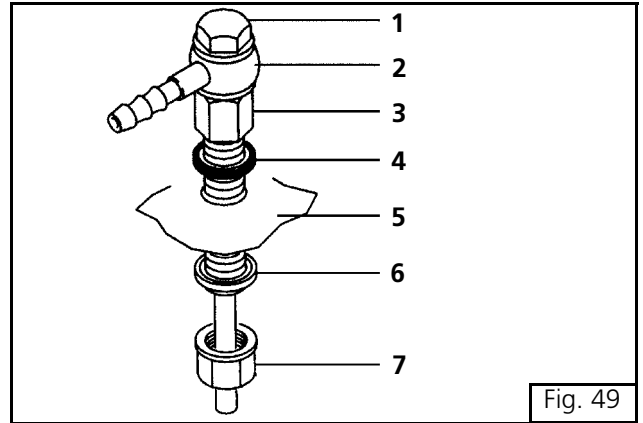

Fig. 49



Re-install fuel sender assembly according to the vehicle manufacturers servicing instructions.

Connect fuel line to fuel sender. Route fuel line forward along existing vehicle fuel lines. Install fuel tank and lines according to vehicle manufacturers servicing instructions.

- (1) Fuel standpipe
- (2) Fuel line clamps - torque 1.0-1.4 Nm (8.8-12.4 lb-in.)
- (3) Fuel line coupler
- (4) Mecanyl fuel line

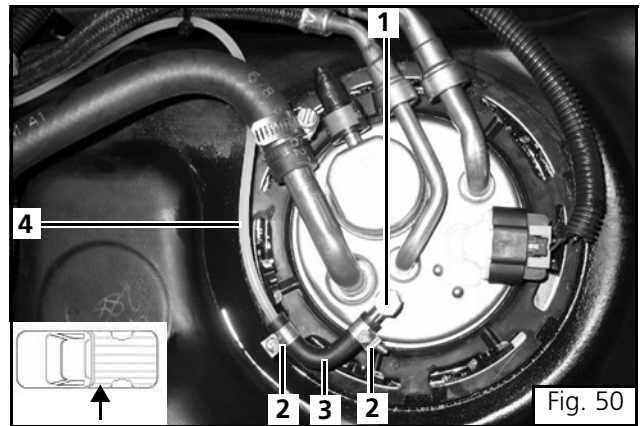

Fig. 50

Route Mecanyl fuel line along existing vehicle fuel lines as shown. Secure fuel line to existing vehicle fuel lines with nylon cable ties as shown.

- (1) Existing vehicle fuel lines
- (2) Nylon cable tie
- (3) Mecanyl fuel line

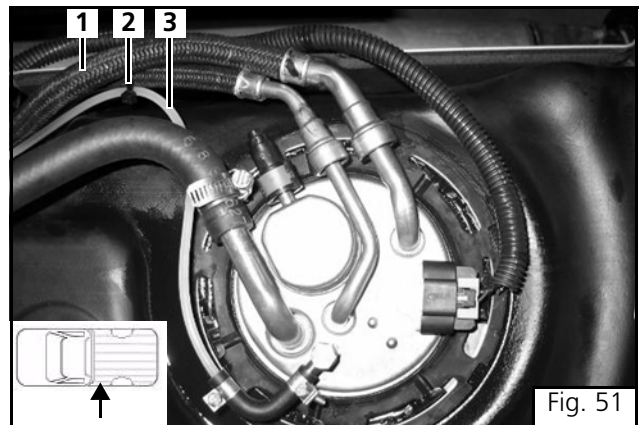

Fig. 51

Fuel Line Routing from Sender to Pump

Continue routing Mecanyl fuel line along vehicle fuel lines as shown.

- (1) Back of cab
- (2) Mecanyl fuel line
- (3) Existing vehicle fuel line clamp
- (4) Top of left frame rail

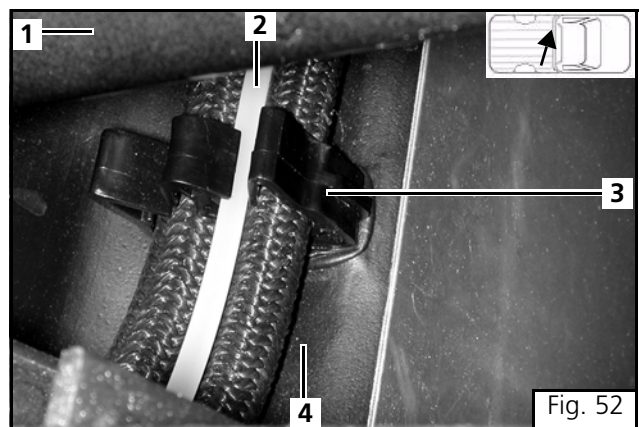
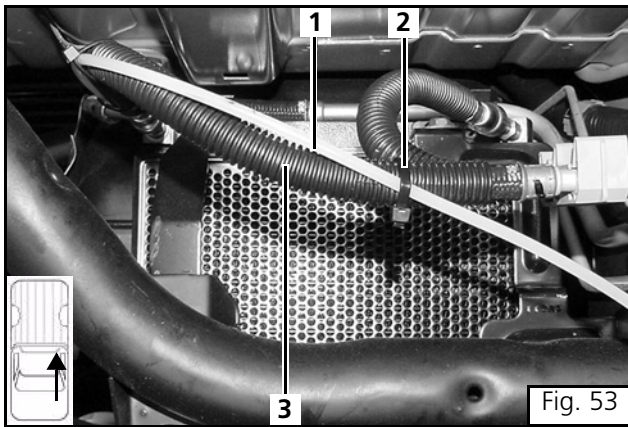
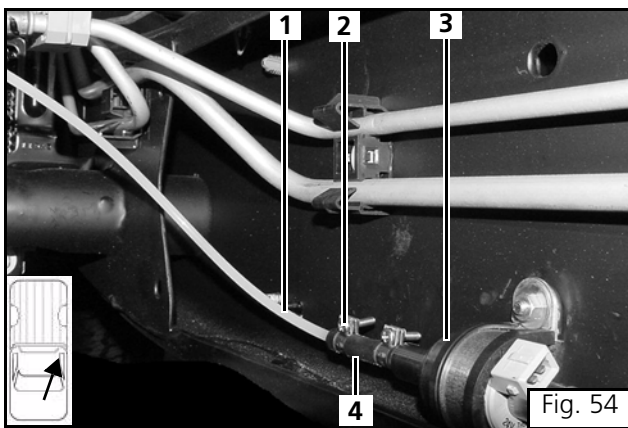

Fig. 52



Continue routing Mecanyl fuel line along vehicle fuel lines as shown.

- (1) Mecanyl fuel line
- (2) Nylon cable tie
- (3) Existing vehicle fuel lines



ATTENTION

Always cut Mecanyl fuel line with a sharp razor knife or razor edged cutter. DO NOT cut with side cutters, scissors or similar tools as doing so will cause a restriction inside the fuel line.

Cut fuel line and connect to fuel pump.

- (1) Mecanyl fuel line
- (2) Fuel line clamp x2 - Torque to 1.0-1.4 Nm (8.8-12.4 lb-in.)
- (3) Fuel pump
- (4) Fuel line coupler

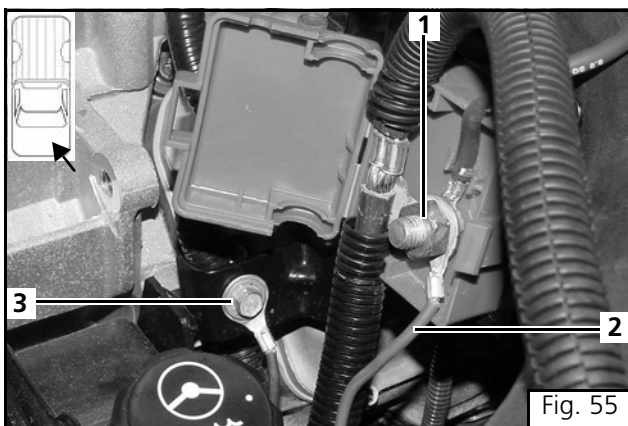

Power Connection

Connect red power lead to existing auxiliary power point underhood. Connect brown ground lead as shown. Reconnect battery ground cable.

- (1) Vehicle auxiliary power point
- (2) Webasto power lead
- (3) Webasto ground lead



Final Inspection Initial Start-up and Concluding Work

Connect battery ground terminal

Final Inspection

Inspect installation for:

- Loose fasteners.
- Exhaust system routing and clamp tightness.
- Combustion air intake tube routing and clamp tightness.
- Loose coolant line clamps.
- Pinched coolant lines.
- Routing of coolant lines and coolant lines securely tied and protected against chafing and related damage.
- Loose fuel line clamps.
- Routing of fuel lines and fuel lines securely tied and protected against chafing and related damage.
- Loose wiring connections and battery connections.
- routing of wiring harness and wiring harness securely tied and protected against chafing and related damage.
- Check operation of vehicle heater fan with Webasto heater OFF.

Initial Start-up

- 1 Top off cooling system with coolant per engine/vehicle manufacturers recommendations.
- 2 Set interior heater control to maximum heat position (hot) and switch off air conditioning system.
- 3 Start the vehicle engine and run on fast idle for 5 minutes to purge any remaining air from the Webasto heater and coolant system. While the engine is running check:
 - Hose connections for leaks.
 - Coolant level in expansion tank. (Add coolant as needed)
- 4 Switch off the engine.

ATTENTION

More than one start-up attempt of the heater may be required to purge air from fuel system before heater will start. Cycle heater Off and On after each failed start attempt until heater starts successfully. After 3 consecutive unsuccessful start attempts, the webasto control unit enters into heater lockout.

See Heater Lockout section for reset instructions.

- 5 Switch on the Webasto heater by means of the instant heat button on timer and check:
 - Timer panel and instant heat indicator illuminates.
 - Circulating pump in operation.
 - Initiation of start-up sequence.
 - Successful start-up and operation.
- 6 Allow heater to run for 20 minutes or until coolant is heated to temperature. Re-tighten all hose clamps.

ATTENTION

Engine coolant temperature gauge may read lower than actual Webasto heater output temperature.

This is due to the location of the temperature gauge sensor on engine.

Concluding Work

- Check that all hose lines, hose clamps, pipe clips and electrical connections are secure. Secure all loose lines and cables with nylon cable ties.
- Spray the heater components and electrical connections with an anti-corrosive wax coating.
- Install all vehicle parts, panels and components removed during heater installation.

Heater Lockout Reset Procedure

The BlueHeat is designed with a lockout safety feature built into the control unit. After 3 consecutive unsuccessful startup attempts, the heater will lock itself out from any further start attempts. The heater may also enter the lockout mode after experiencing an overheat condition.

Reset Heater "Lockout" mode by performing the following procedure:

- 1 Ensure timer or switch is in the "OFF" position. Turn timer or switch to the "On" position. Remove main fuse F2 (20 Amp), reinsert after 5 seconds.
- 2 Cycle timer or switch off and then back on once more. Remove fuse F2 once again and reinsert after 5 seconds. Heater should attempt to start after inserting fuse.

ATTENTION

- The engine coolant must be below 86 °F (30 °C) before the Webasto heater will attempt to start.
- Should the heater fail to start or operate correctly, contact your Webasto technical representative at:

1-800-555-4518

Electrical Harness Schematic - Part 1, Heater Control

- B2 : TEMPERATURE SENSOR - COOLANT
- E : CERAMIC IGNITOR / FLAME DETECTOR
- F1 : 25A BLOWER INTERLOCK
- F2 : 20A HEATER
- F3 : 2A TIMER
- K1 : IGNITION BLOWER CONTROL RELAY
- K2 : BLOWER RELAY 1
- K3 : BLOWER RELAY 2
- M1 : COMBUSTION AIR FAN
- M2 : COOLANT CIRCULATING PUMP
- M3 : VEHICLE BLOWER HTR/AC
- P1 : TIMER 24 HOUR
- R1 : RESISTOR 10HM/50W
- X9 : DIAGNOSTIC LINK
- Y1 : FUEL METERING PUMP

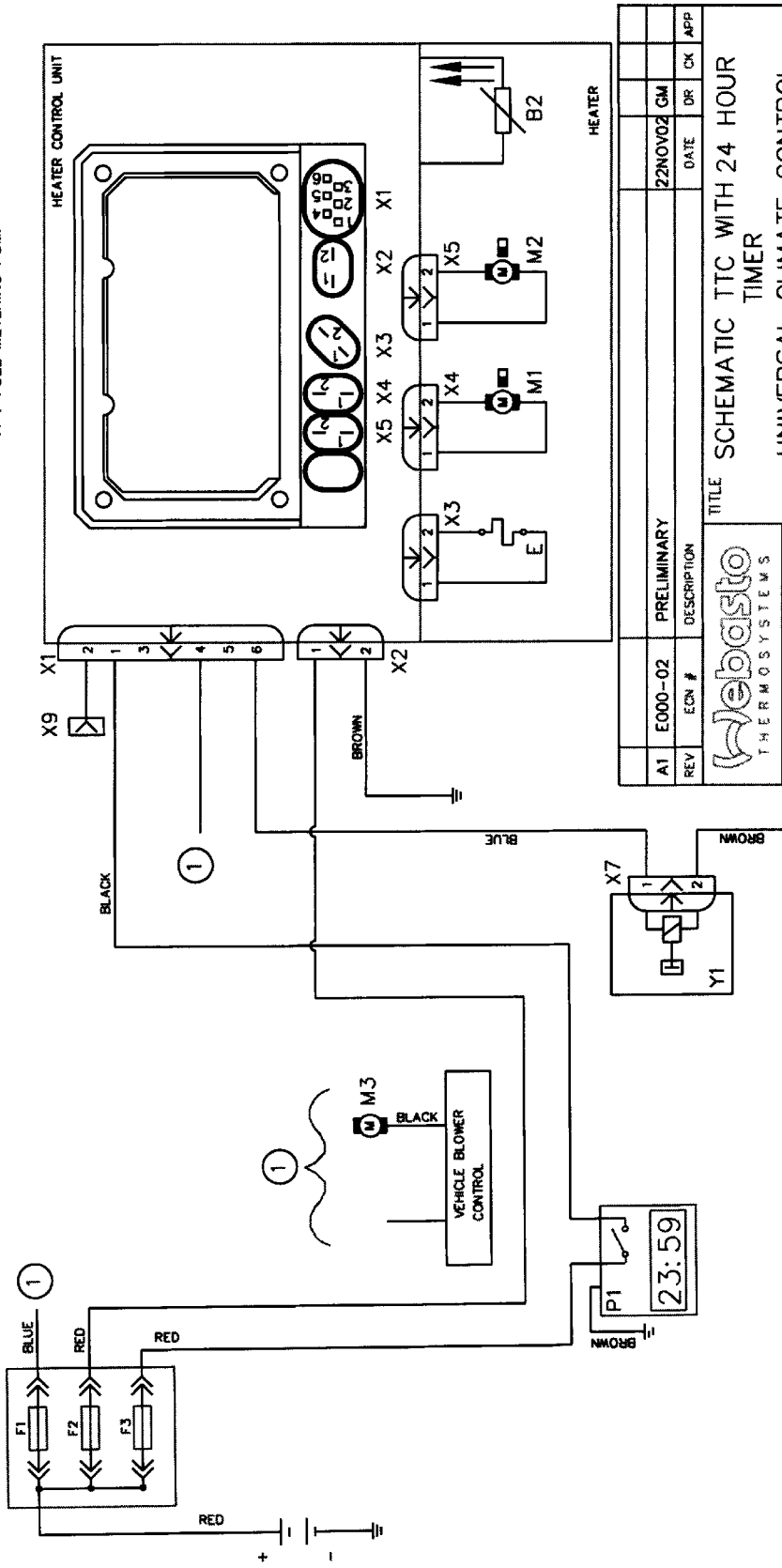

A1	E000-02	PRELIMINARY							
REV	ECN #	DESCRIPTION	DATE	DR	CK	APP			
			22NOV02	GM					
							TITLE SCHEMATIC TTC WITH 24 HOUR TIMER UNIVERSAL CLIMATE CONTROL PAGE 1 OF 2		
DR	21JAN03	G.MILLER							
CHK	21JAN03	G.MILLER							
APPR	21JAN03	R.FERRIS							
SCALE NTS			DWG NO. 908265A-1						
THIS DRAWING AND INFORMATION CONTAINED HEREIN IS PROPRIETARY TO WEBASTO THERMOSYSTEMS INC. AND SHALL NOT BE REPRODUCED OR TRANSMITTED IN ANY FORM OR BY ANY MEANS, ELECTRONIC OR MECHANICAL, INCLUDING PHOTOCOPYING, RECORDING, OR BY ANY INFORMATION SYSTEMS, WITHOUT THE WRITTEN PERMISSION OF WEBASTO THERMOSYSTEMS INC.							THIRD ANGLE PROJECTION		
							ALL DIMENSIONS ARE IN mm 908 265		

① SEE PAGE 2 OF 2 (908265A-2) FOR BLOWER MOTOR CONTROL

Electrical Harness Schematic - Part 2, HVAC Blower Control

- B2 : TEMPERATURE SENSOR - COOLANT
- E : CERAMIC IGNITOR / FLAME DETECTOR
- F1 : 25A BLOWER INTERLOCK
- F2 : 20A HEATER
- F3 : 2A TIMER
- K1 : IGNITION BLOWER CONTROL RELAY
- K2 : BLOWER RELAY 1
- K3 : BLOWER RELAY 2
- M1 : COMBUSTION AIR FAN
- M2 : COOLANT CIRCULATING PUMP
- M3 : VEHICLE BLOWER HTR/AC
- P1 : TIMER 24 HOUR
- R1 : RESISTOR 10HM/50W
- X9 : DIAGNOSTIC LINK
- Y1 : FUEL METERING PUMP

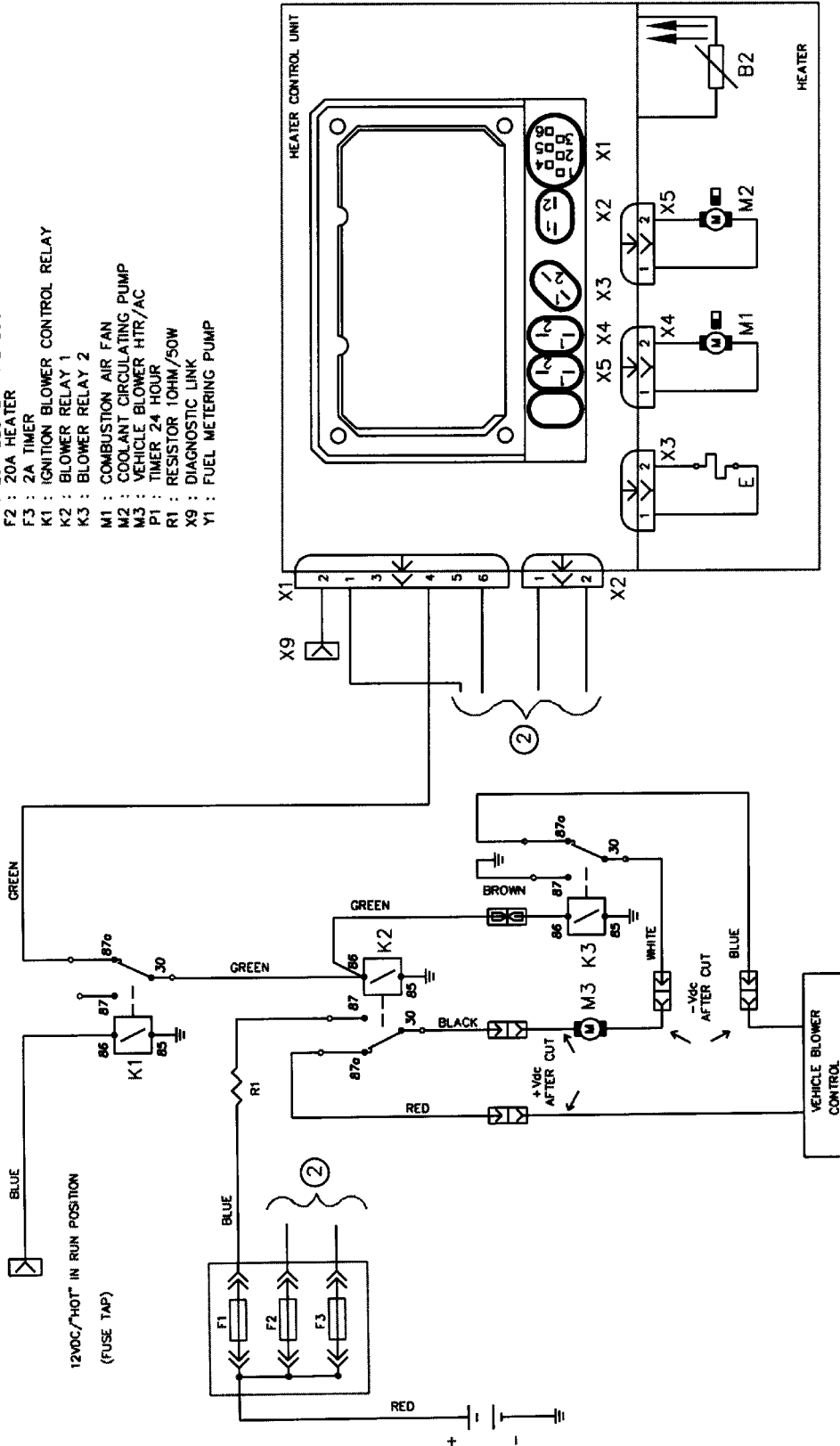

		TITLE SCHEMATIC TTC WITH 24 HOUR TIMER UNIVERSAL CLIMATE CONTROL PAGE 2 OF 2	
DR	DATE	NAME	
CHK	21JAN03	G.MILLER	
APPR	21JAN03	R.FERRIS	
SCALE		NTS	DWG NO. 908265A-2
THE DRAWING AND INFORMATION CONTAINED HEREIN IS PROPRIETARY TO WEBASTO THERMOSYSTEMS INC AND SHALL NOT BE REPRODUCED, COPIED, OR USED FOR MANUFACTURE OR FOR ANY OTHER PURPOSE WITHOUT THE WRITTEN PERMISSION OF WEBASTO THERMOSYSTEMS INC.			THIRD ANGLE PROJECTION
			ALL DIMENSIONS ARE IN mm 908 265

FUNCTION : WHEN HEATER IS SWITCHED ON AND COOLANT REACHES 60°C (140°F) THE WEBASTO HEATER SENDS A SIGNAL THROUGH K1 TO K2 AND K3 VEHICLE BLOWER WILL COME ON AT LOW SPEED IF A VEHICLE IGNITION SIGNAL IS PRESENT AT K1, THE VEHICLE RETURNS TO NORMAL HVAC/OPERATOR CONTROLS

② SEE PAGE 1 OF 2 FOR ALL OTHER HEATER CONTROLS

Heater Plumbing Schematic - Inline Method

WEBASTO THERMO TOP C INLINE COOLANT SCHEMATIC

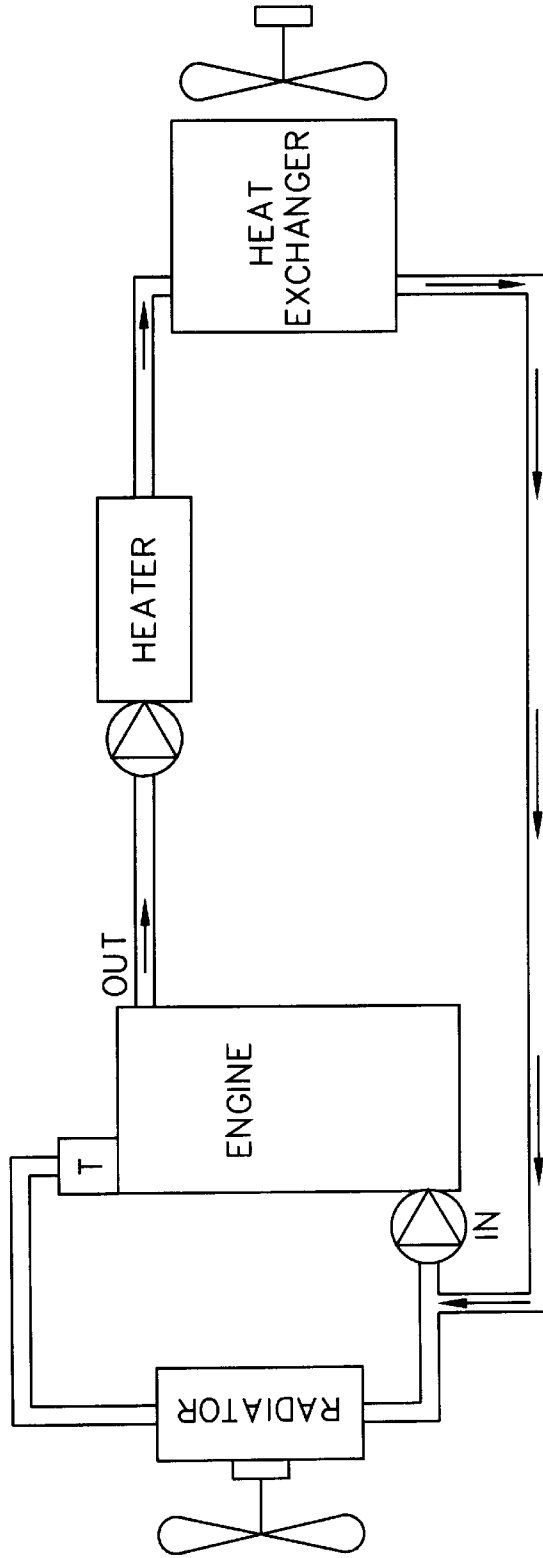

 = THERMOSTAT

 = COOLANT PUMP (2 PLC'S)

REV	ECN #	DESCRIPTION	DATE	DR	CK	APP	MG
A1	E1B2-02	DRAWING RELEASED	21AUG02	BW	EK		
TITLE			DATE		DR	CK	APP
Webasto THERMOSYSTEMS			COOLANT SCHEMATIC TTC INLINE		DATE		MG
DR	21AUG02	B. WALKER	SCALE		DWC NO.		
CHK	21AUG02	E. KOPP	NTS		908255A		
APPR	21AUG02	M. GRUPP					
THIS DRAWING AND INFORMATION CONTAINED HEREIN IS PROPRIETARY TO WEBASTO THERMOSYSTEMS INC. AND SHALL NOT BE REPRODUCED, COPIED, OR USED FOR MANUFACTURE OR FOR ANY OTHER PURPOSE WITHOUT THE WRITTEN PERMISSION OF WEBASTO THERMOSYSTEMS INC.							ALL DIMENSIONS ARE IN mm
							THIRD ANGLE PROJECTION
							
							908255A

Documentation Feedback Form

Detailed user feedback is extremely valuable to us in producing accurate, comprehensive, and useful documentation. Please complete the relevant parts of the form below; your comments and suggestions will help us improve our documentation. Thank you.

	Unsatisfactory			Excellent	
Please rate the overall usefulness of the documentation.	1	2	3	4	5
Rate the completeness and clarity of the instructions: did the procedures provide enough detail?	1	2	3	4	5

What could be added or clarified? _____

Please list any other comments, concerns, or suggestions. _____



Please provide contact information below.

Name: _____

Company Name: _____

City / State: _____

Phone: _____

Email: _____

Mail to:
Webasto Product N. A., Inc.
15083 North Road
Fenton, MI 48430
Attention: Documentation Group
or
Fax to: (810) 593-6137



Webasto Product N.A., Inc.

Technical Assistance Hotline

USA: (800) 555-4518

Canada: (800) 667-8900

www.webasto.us

www.techwebasto.com

Sender Unit / Standpipe Template for Model Year 2004/05 Vehicles

Cut out along solid outline of template.

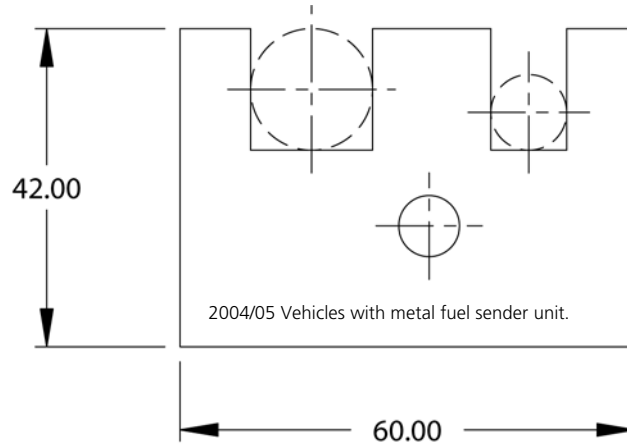

Cut out along solid outline of template.

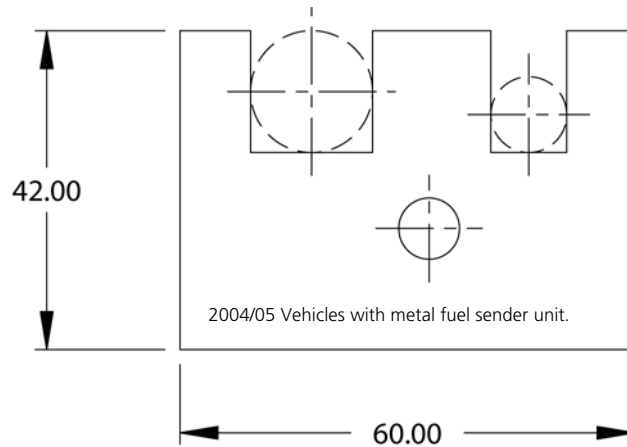

(Spare template)

