

# Water Heater Unit



Feel the drive

**Thermo Top E Auxiliary Heating**  00 0003

**Thermo Top C Auxiliary Heating**  00 0002

**Thermo Top P Auxiliary Heating**  00 0104

## Installation Instructions

### Lexus GS 450h

Gasoline with the Lexus Hybrid System

From model year 2006

For left-hand drive vehicles only



#### **WARNING!**

Hazard warning:

Incorrect installation or repair of Webasto heating systems may cause a fire or result in the emission of carbon monoxide, which can be fatal. Serious or fatal injuries can be caused as a result.

Specialist company training, technical documentation, specialized tools and equipment are required to install and repair Webasto heating and cooling systems.

NEVER attempt to install or repair Webasto heating or cooling systems if you have not successfully completed the company training and thereby acquired the required technical skills or if you do not have access to the required technical documentation, tools and equipment to carry out correct installation and repairs.

ALWAYS follow all Webasto installation and repair instructions and observe all warning instructions.

Webasto does not accept any liability for defects and damage that are attributable to an installation by untrained staff.

## Table of Contents

Validity	2	Preparing the Installation Location	14
Heater Unit / Installation Kit	3	Assembling the Bracket	14
Foreword	3	Installing the Heater Unit	15
General Instructions	3	Fuel Connection	16
Special Tools	3	Water Connection	21
Explanatory Notes on the Document	4	Combustion Air	27
Preliminary Work	5	Exhaust System	28
Heater Unit Installation Location	5	Final Work	30
Electrical Connections	6	Operating instructions for the end customer	31
Preparing the Electronics	7	Tank Extracting Device Template	32
Blower Control	10		
Remote Start Option	12		
Thermo Call Option	13		

## Validity

Manufacturer	Model	Type	EG-BE No. / ABE
Lexus	GS 450h	HS 19 (a)	e6 * 2001 / 116 * 0106 * ...

Engine type	Engine	Power in kW	Engine capacity in cm <sup>3</sup>
2GR-FSE	Gasoline	218	3456

Vehicle and engine types, equipment variants as well as national specifications, which are not listed in these installation instructions, have not been tested. Installation according to these installation instructions may, however, be possible.

The installation location of a time switch and summer / winter switch should be confirmed with the end customer before installation.

## Heater Unit / Installation Kit

Amount	Description	Order no.:
1	Commercial supply of required control	See price list
1	Installation kit for Lexus GS 450h	1,311,239A

Recommended heater unit for the relevant vehicle class:

Vehicle	Heater unit
Compact car	Thermo Top E
Mid-class, station wagon	Thermo Top C
Luxury, van, off-roader	Thermo Top P

Select the heater unit based on the size of the vehicle passenger compartment and the customer's comfort requirements.



### Foreword

These installation instructions apply to the vehicles Lexus GS 450h Gasolineengine with the Lexus Hybrid System.

– Re. validity, see page 2 – from model year 2006 and later, assuming technical modifications to the vehicle do not affect installation and any liability claims are excluded. – Depending on the vehicle version and equipment, modifications may be necessary during installation with respect to these installation instructions.

However, the stipulations in the "installation instructions" and "operating and maintenance instructions" for the *Thermo Top C/P/E* are to be observed in any event.

The corresponding rules of technology and any information from the vehicle manufacturer should be observed during the installation work.

### General Instructions

Installation should be carried out according to the general, standard rules of technology. Unless specified otherwise, fasten hoses, lines and cable harnesses to original vehicle lines and cable harnesses using cable clips.

Sharp edges should be fitted with edge protectors (split open plastic hose).

Spray unfinished body areas, such as bore holes, with anti-corrosion wax (Tectyl 100K, Order no. 111329).

### Special Tools

- Torque spanner for 2.0 - 10 Nm
- Vise-grip wrench
- Riveting nut tool

## Explanatory Notes on the Document

To provide you with a quick overview of the individual working steps, you will find an identification mark on the outside top right corner of the page in question.

### Mechanics

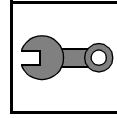

### Electrics

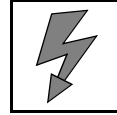

### Water connection

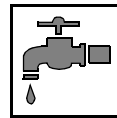

### Fuel connection

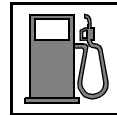

### Exhaust system

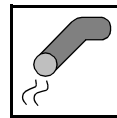

### Combustion air

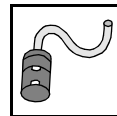

Special features are highlighted using the following symbols:



Specific risk of injury or fatal accidents.



Specific risk of damage to components.



Specific risk of fire or explosion.



Reference to general installation instructions of Webasto components or to the manufacturer's vehicle-specific documents.



Reference to a special technical feature.

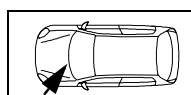
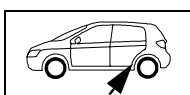

The arrow in the vehicle icon indicates the position on the vehicle and the viewing angle.

**Preliminary Work**

**WARNING!**

- Let off pressure in the cooling system.
- Copy the factory number from the original type label to the duplicate type label.
- Remove years that do not apply from the duplicate label.
- Attach the duplicate label (type label) in the appropriate place.
- Completely remove the air filter with intake hose.
- Remove left fuse and relay box.
- Open the tank cap, ventilate the tank.
- Close the tank cap again.
- Disconnect the battery.
- Loosen the right and left wheel-house panel.
- Remove the underride protection.
- Remove the bumper.
- Lower cover fuel lines.
- Remove the rear seat bench.
- Open the left tank mounting service lid
- Remove left tank mounting according to manufacturer's instructions.
- Remove the lower cover to the right footwell
- Remove the side cover on the right-center console (only for Telestart T100 HTM).
- Please remove page 31 "Operating instructions for the end customer" and add this to the vehicle operating instructions.

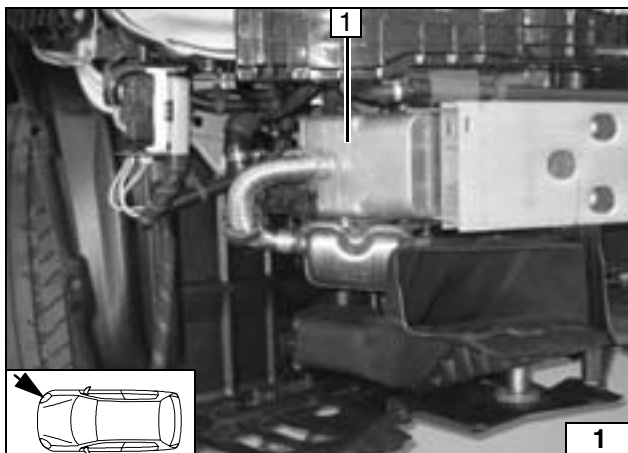

**Heater Unit Installation Location**

1 Heater unit

**Installation location**



**Electrical Connections**

**Cable harness feed-through**

- 1 Protective rubber sleeve

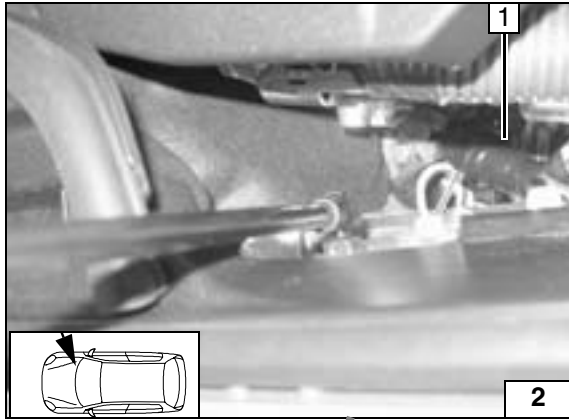

**Time switch**

- 1 Time switch

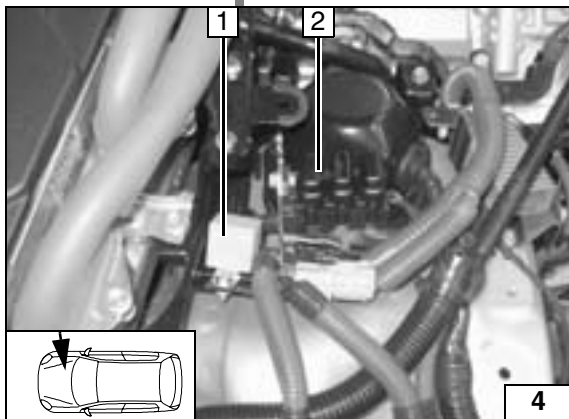
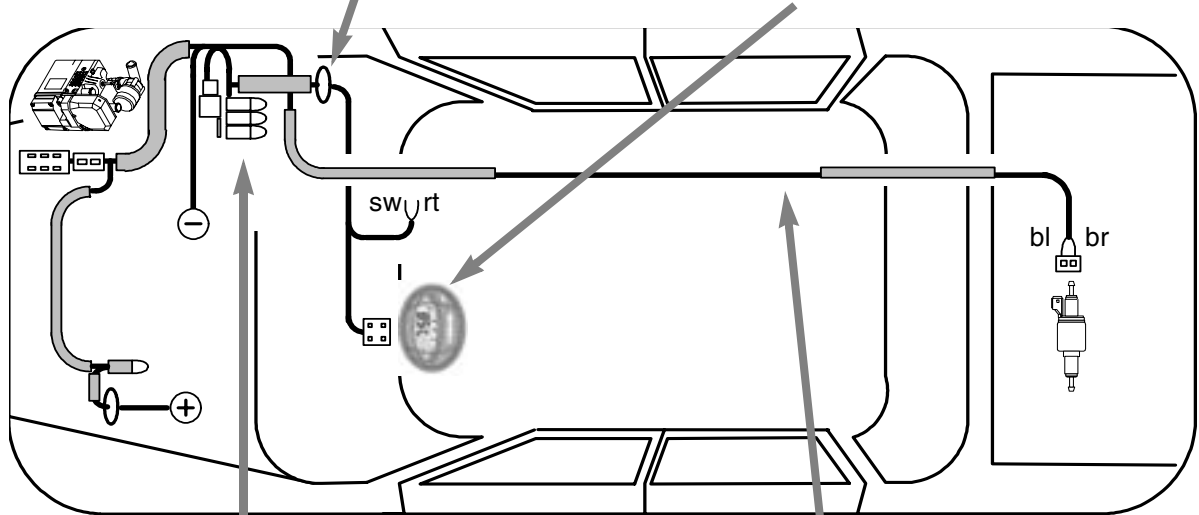
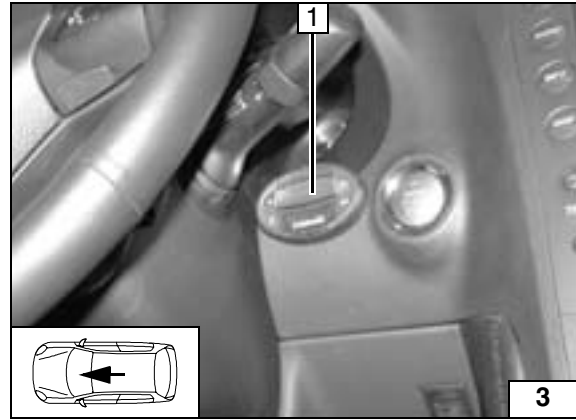

**Fuse holder, K3 relay**

- 1 K3 relay
- 1 Fuse holder

Note the assembly instructions on page 7.

Wait to install the metering pump cable harness until later, together with fuel pipe along the original vehicle fuel lines in the Ø 10 mm tube shaft [2x] on the underbody.



**Cable harness installation diagram**

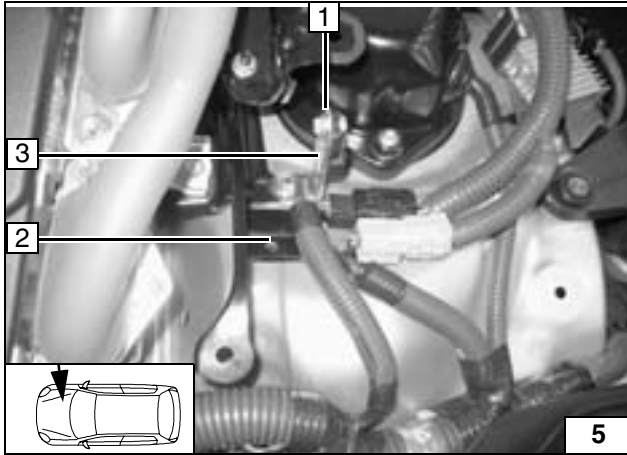

## Preparing the Electronics

Bend the fastening strap **3** according to the illustration and fasten with the original vehicle bolt.

- 2 Drill a Ø 5 mm bore hole
- 1 Fuse holder, M5x12 bolt, flanged nut M5

**Prepare the fuse holder installation**

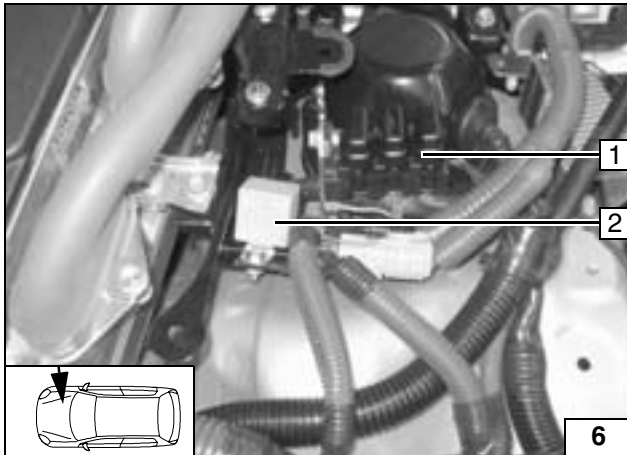

Assemble the fuse holder **1** on the preassembled retaining plate.

- 2 Relay K3, M5x12 bolt, flanged nut M5

**Installing lines**

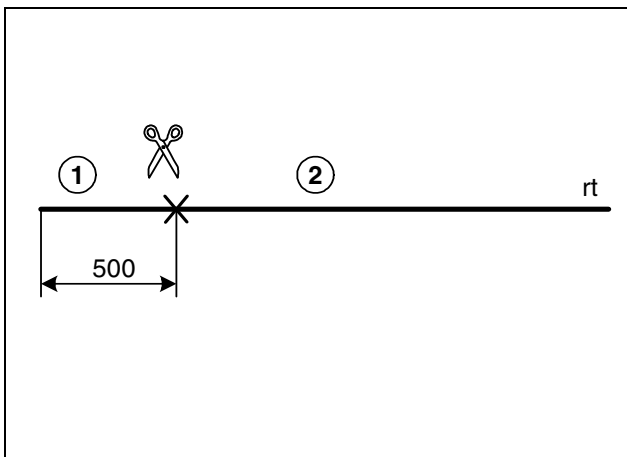

**Cutting wires into sections**

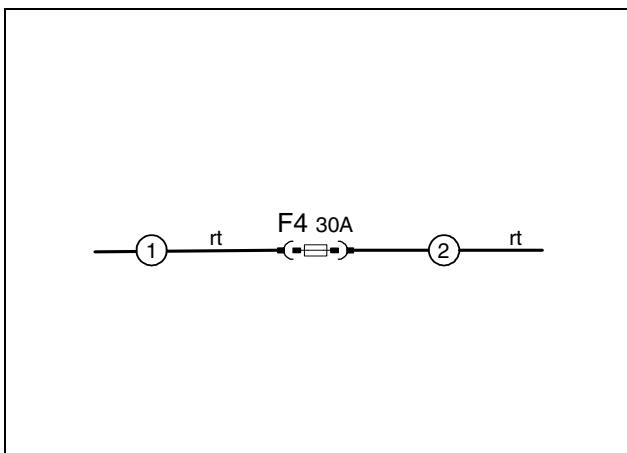

**Preassembling fuse F4**

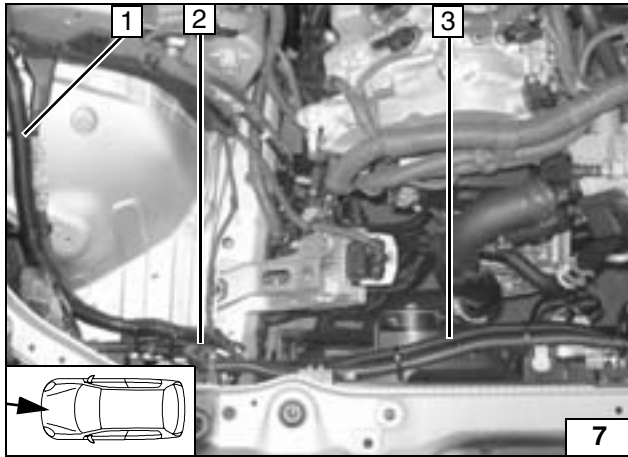

Cut approx. 300mm from the  $\varnothing$  20mm tube shaft. Install the heater unit cable harness, Mecanyl fuel line, positive connection for the header unit cable harness in the  $\varnothing$  20mm 1 tube shaft.

Run the fuel line, heater cable harness to the heater unit installation location.

Connect the red (rt) 1500 lg. wire with shrinkable butt connectors 2 to the positive supply cable on the cable harness.

Shorten  $\varnothing$  10 mm tube shaft by 100 mm. Run the red (rt) 1500 lg line through the  $\varnothing$  10 mm tube shaft 3 to the left fuse and relay holder.



## Installing lines

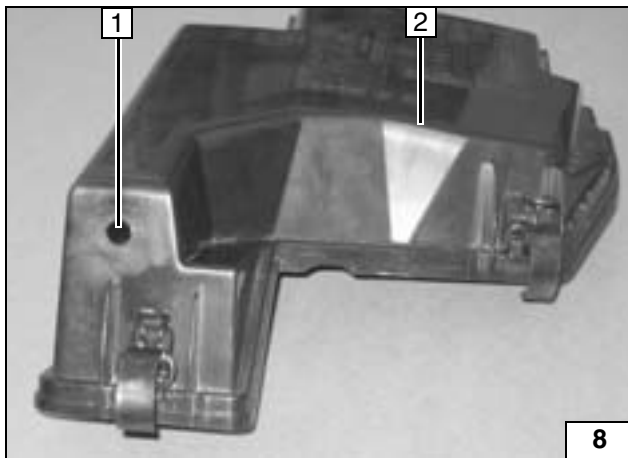

Drill a  $\varnothing$  9mm bore hole 1 in the cover of the fuse and relay holder 2 according to the figure.



## Preparing the positive supply

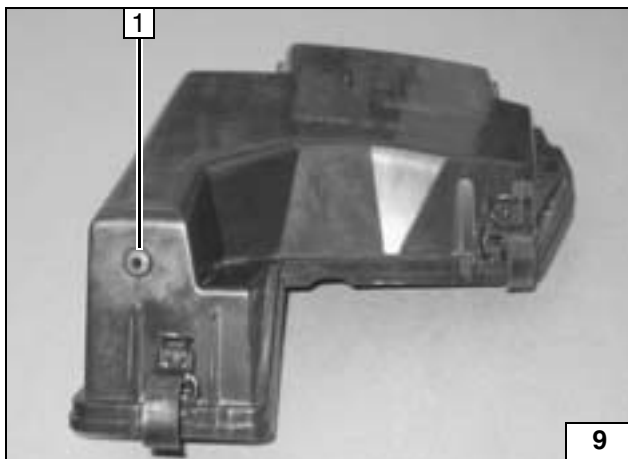

1 Cable sleeves

## Inserting the cable sleeves

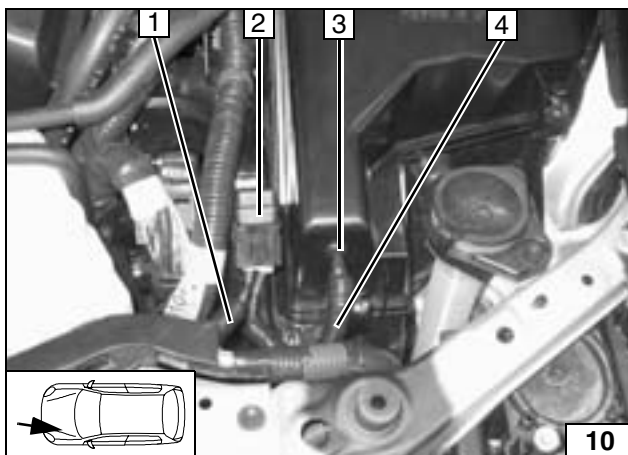

Drill the  $\varnothing$  4.5 mm bore hole for the fuse bracket 2 according to the figure, fasten the fuse bracket with the 5.5x13 self-tapping screw.

Insert the red (rt) 500 mm line in the remaining 100 mm tube shaft 4 and pull this through the cable sleeve 3.

Wrap the tube ends with insulation tape.

1 Red (rt) wire, tube shaft



## Installing lines



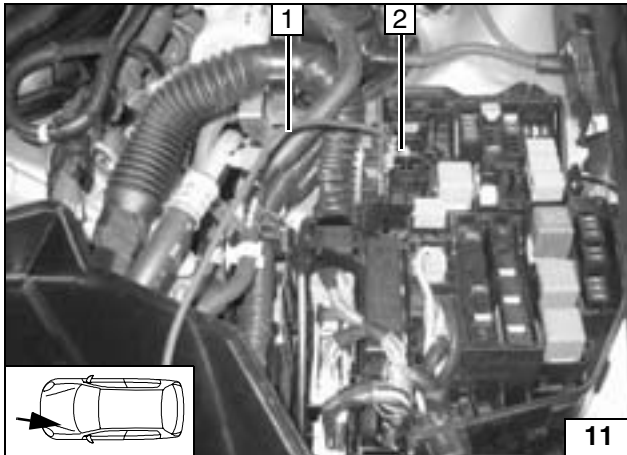

- 1 Red (rt) wire, Ø 6 mm pointed cable socket
- 2 Positive base

**Connecting to the positive supply**

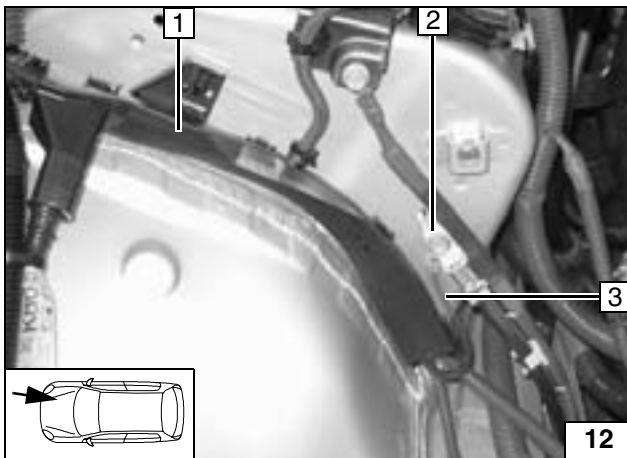

Run the brown (br) wire for the heater unit cable harness ground supply **3** through the cable socket **1** to the grounding point **2** and connect.



**Connecting the ground supply**

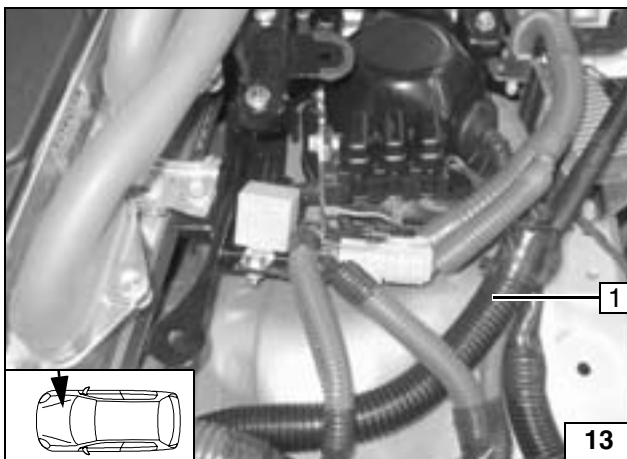

Pull the rt and sw (red and black) lines from the K3 blower relay and the time switch cable harness into the remaining Ø20 mm tube shaft and to the cable feed-through.

Wrap the tube ends with insulation tape.

**Note:**

Pull the lines from the K3 blower relay and the time switch cable harness from the interior through the feed-through.



**Installing lines**

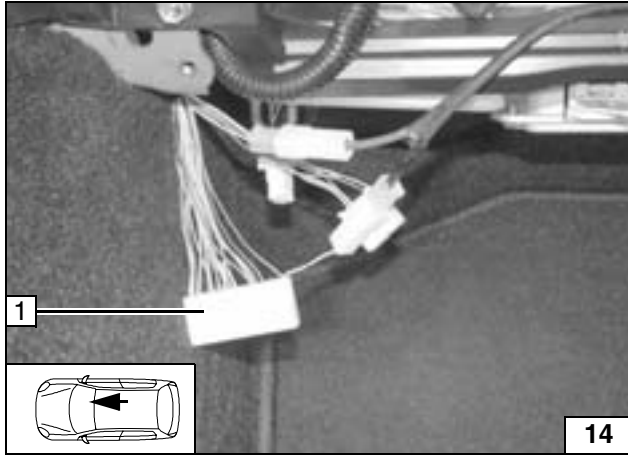

## Blower Control

Connect to 40-pin connector L 52 (A) pin 21 from the A/C amplifier.  
 Connect with enclosed blade receptacles according to the circuit diagram.  
 Replace fuse F3 with 10A.

1 40-pin connector L52.

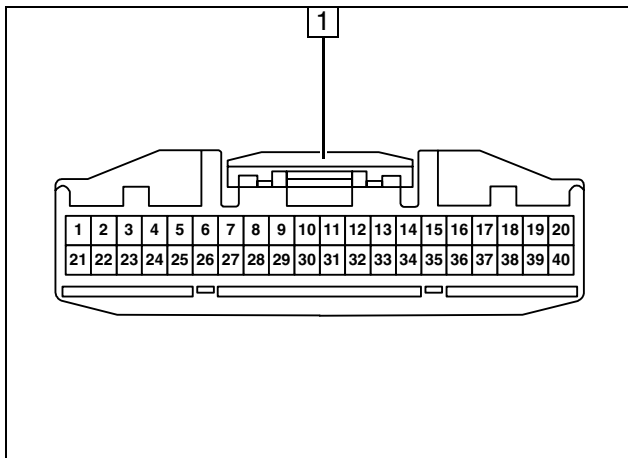

1 Connector L 52 (A), contact side



Connecting the A/C amplifier

connector L 52 (A)

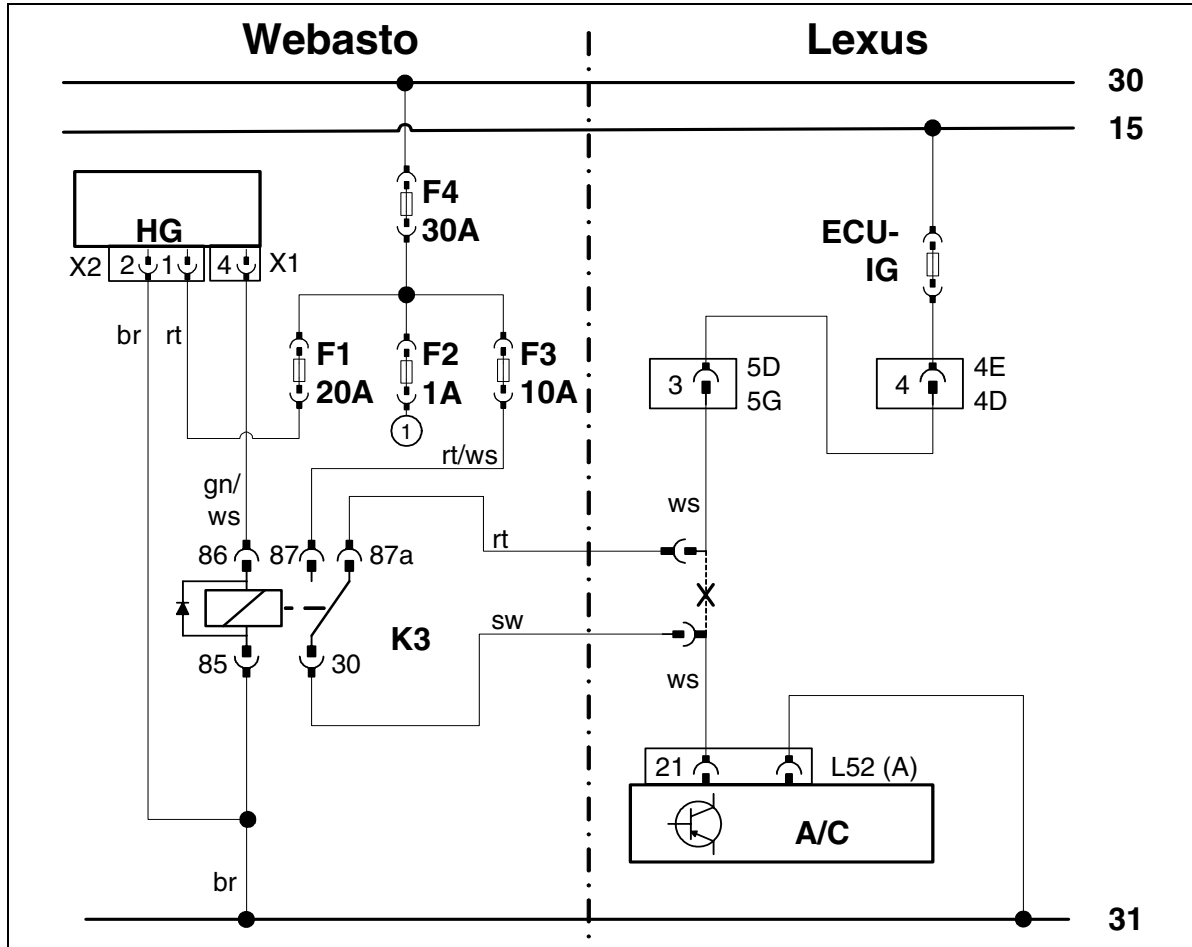

Automatic air conditioning circuit diagram

Webasto components		Lexus components		Colors and symbols	
HG	Heater unit TT-C/E	ECU-IG	Fuse, 10A	rt	red
F1	Fuse, 20A	4E/4D	Plug-in connection	ws	white
F2	Fuse, 1A	5D/5G	Plug-in connection	sw	black
F3	Fuse, 10A	A/C	A/C amplifier	br	brown
F4	Fuse, 30A	L52 (A)	40-pin connector A	gn	green
K3	Blower relay				
1	Operating control				
				X	Splitting point

Legend

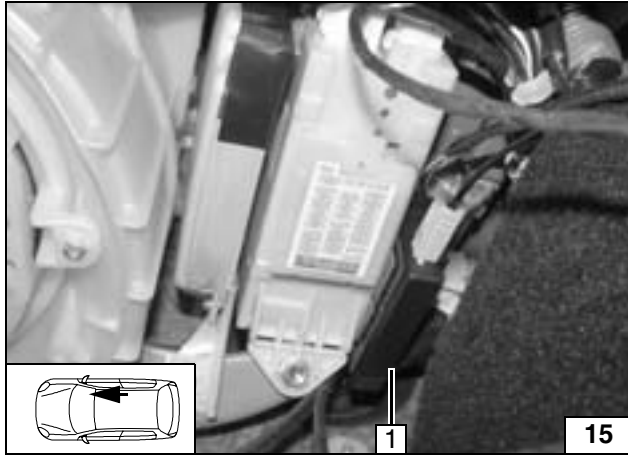

### Remote Start Option

Attach the receiver with double-sided Velcro tape on the blower unit according to the figure.

- 1 Receiver



Assembling the receiver

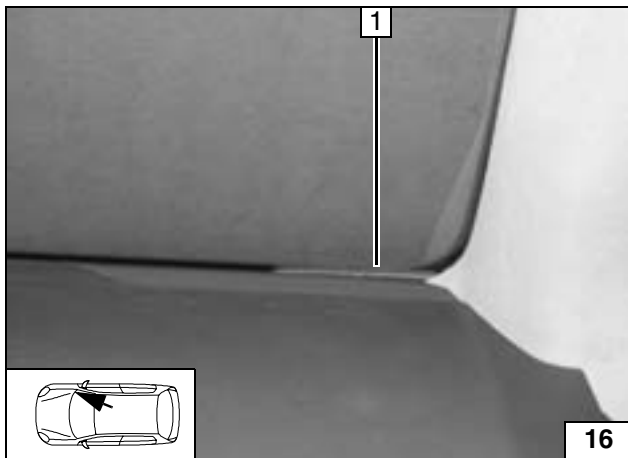

- 1 Antenna

Assembling the antenna

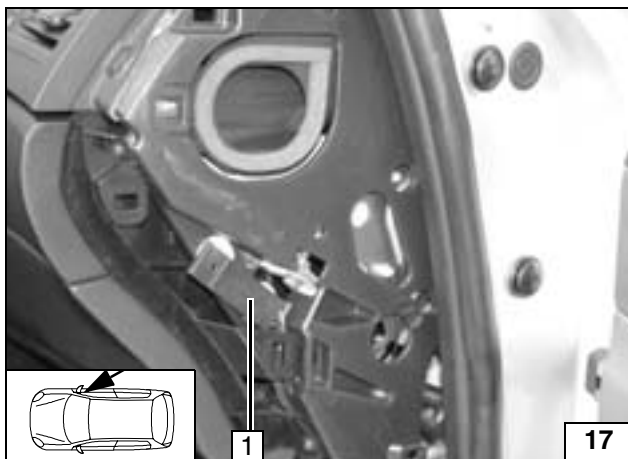

Temperature gauge only with remote T100 HTM

- 1 Temperature gauge

Assembling the temperature gauge

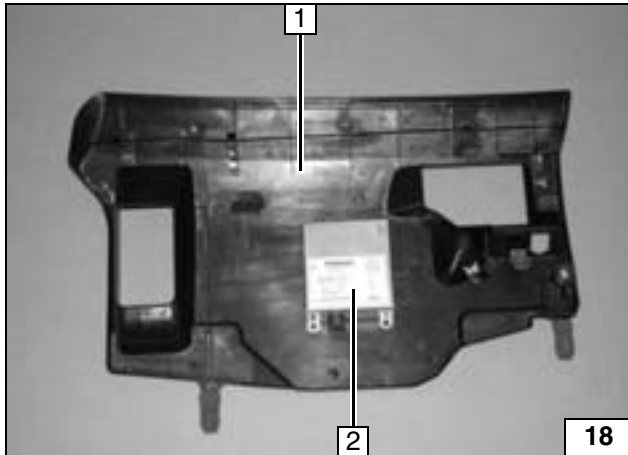

**Thermo Call Option**

Remove the insulation mat receiver bracket. Attach the receiver with double-sided Velcro tape on the footwell cover on the passenger side.

- 1 Footwell cover on passenger side
- 2 Receiver



**Assembling the receiver**

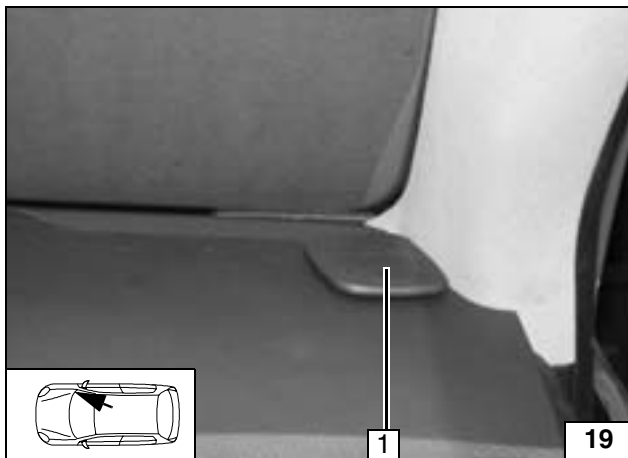

- 1 Antenna

**Assembling the antenna**

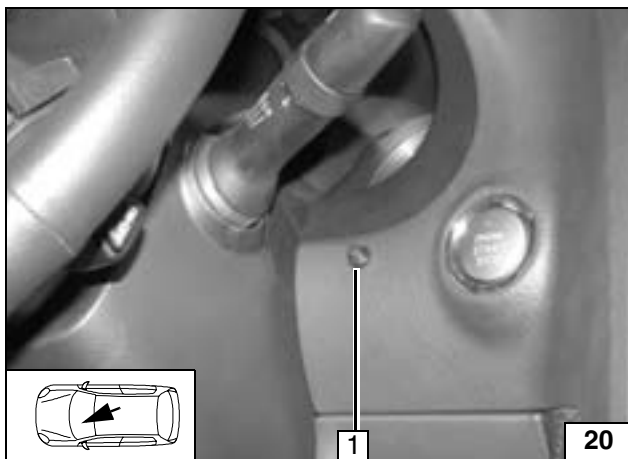

- 1 Tip switch

**Assembling the tip switch**

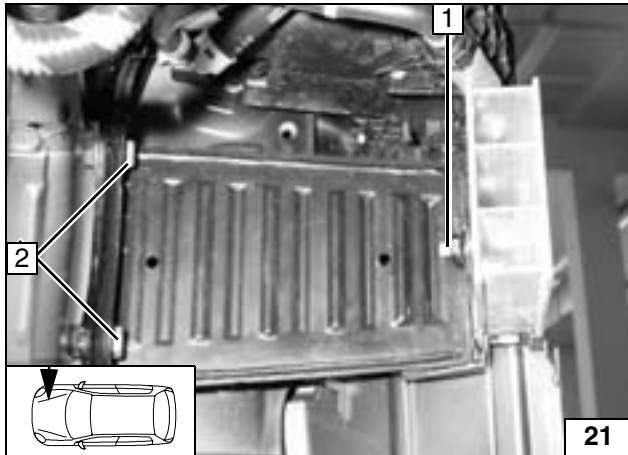
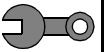

## Preparing the Installation Location

Remove original vehicle bolt at position 1.  
Drill open the weld nut to to  $\varnothing$  10.5mm  
Remove original vehicle bolt 2, this will be used again.

- 1 Original vehicle bolt M10, weld nut



**Drill open weld nut**

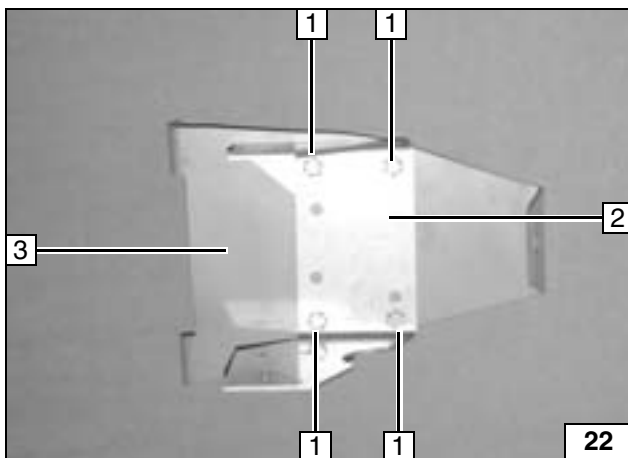

## Assembling the Bracket

- 3 Additional bracket
- 2 Heater unit bracket
- 1 M6x12 bolt, flanged nut [4x each]

**Preparing the bracket**

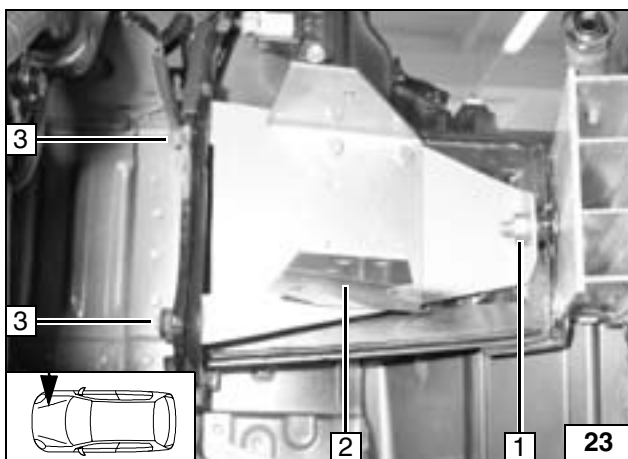

Insert two washers between weld nut and bracket.

- 2 Pre-assembled bracket
- 3 Original vehicle bolt [2x]
- 1 M10x45 bolt, washer [2x], spring washer, M10 nut



**Assembling the bracket**

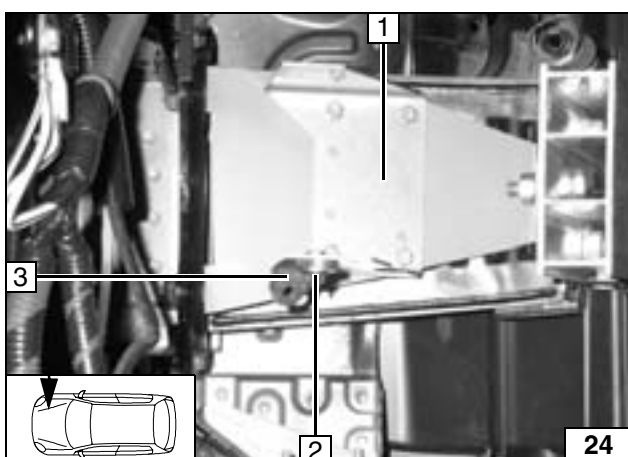

Bracket opened to approx. 120°.

- 1 Pre-assembled bracket
- 3 Angle bracket
- 2 M6x20 bolt, body washer, M6 flanged nut



**Assembling the bracket**

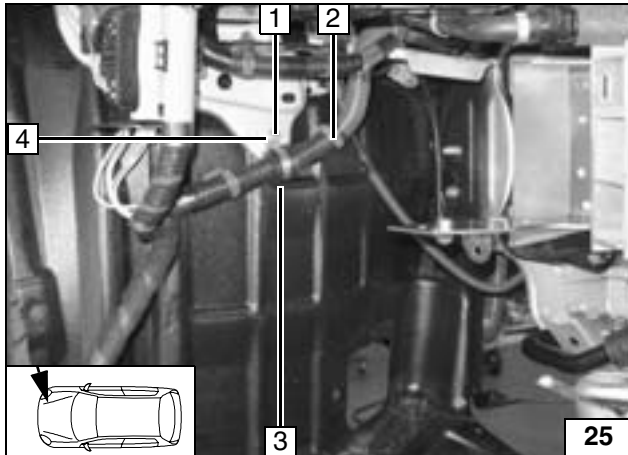
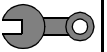

Assemble the original vehicle cable harness<sup>2</sup> on the drill hole **1** with rubber tube clamp  $\varnothing$ 18mm **3** according to the illustration.

**4** M6x20 bolt, flanged nut M6



**Attaching the cable harness**

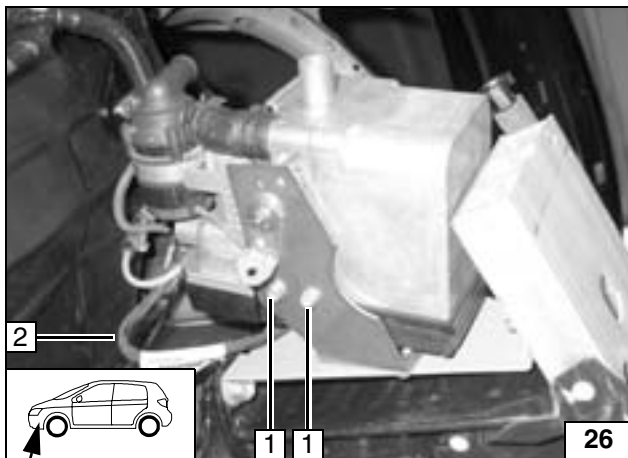

## Installing the Heater Unit

Prior to assembly, put on the heater unit cable harness  
Eject screw bolt tightening torque 10 Nm!

**2** Heater unit cable harness  
**1** Eject screw bolt [2x]



**Assembling the heater unit**

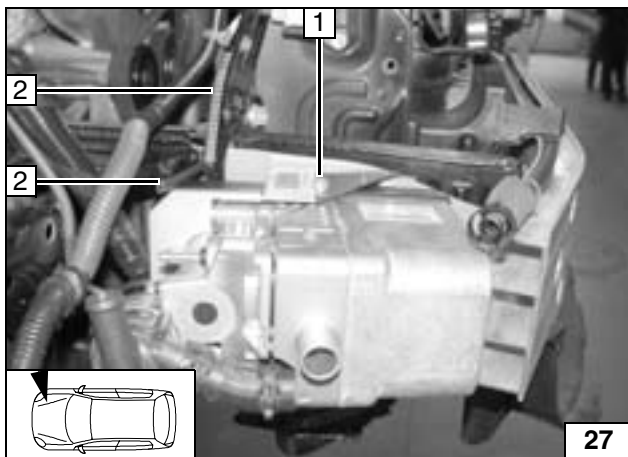

Eject screw bolt tightening torque 10 Nm!

**1** Eject screw bolt  
**2** Edge protection [2x 100mm long]



**Assembling the heater unit**

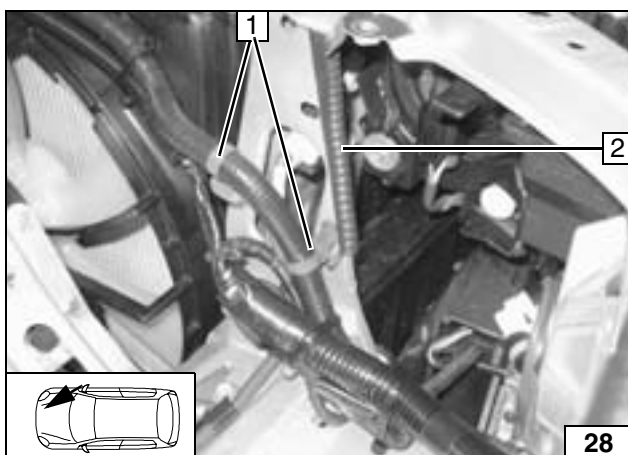

Assemble the 100 mm edge protection profile **2** accordingly.  
Unclip the original vehicle cable harness [2x]



**Assembling the edge protection**



**Fuel Connection**

**CAUTION!**

Open the vehicle's tank-cap lock, ventilate the tank and then re-close the tank lock.

Catch any fuel running off with an appropriate container.

Install fuel line and metering pump cable harness so that they are protected against stone impact. Unless specified otherwise, always fasten using cable clips.

Fit the fuel line and cable harness with edge protectors around sharp edges.

**WARNING!**

The fuel line and cable harness to the metering pump should be installed based on Cable Harness diagram or page 7.

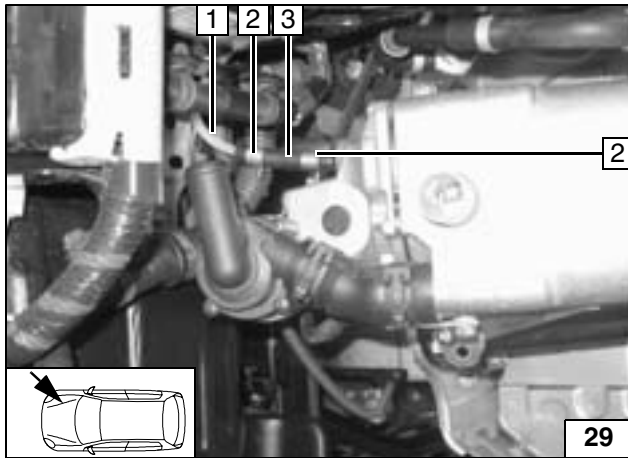

- 1 Mecanyl fuel line
- 2 Ø 10mm hose clamps [2x]
- 3 Hose section

**Connec-  
ting to the  
heater unit**

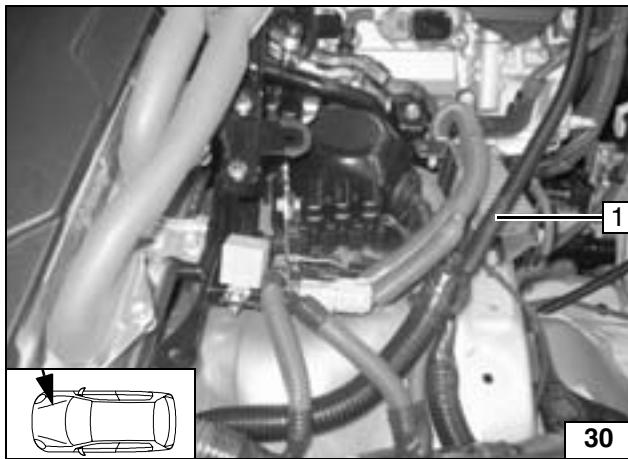

Insert the heater unit cable harness and metering pump cable harness in the Ø 10mm hose shaft 1 .



Wrap the tube ends with insulation tape.

**Installing  
lines**

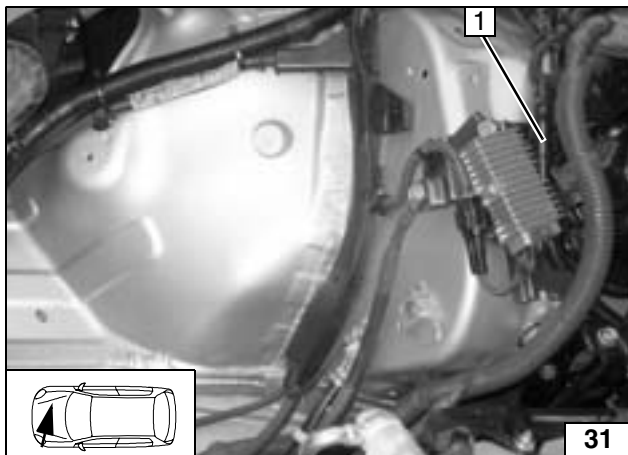

Run the tube shaft 1, the Mecanyl fuel pipe and the metering pump cable harness along the original vehicle lines to the underbody.



**Installing  
lines**



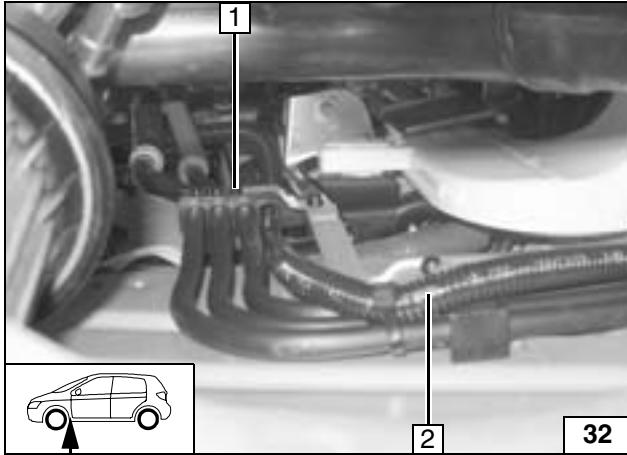

Run the tube shaft **2**, the Mecanyl fuel pipe and the metering pump cable harness along the original vehicle lines **1** to the underbody and secure with cable clips.



**Installing lines**

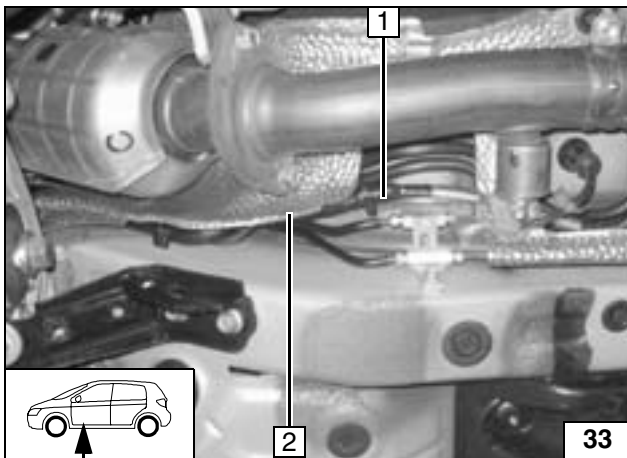

Run the tube shaft, the Mecanyl fuel pipe and the metering pump cable harness along the original vehicle lines to the underbody and secure with cable clips. Ensure sufficient distance to the heat protection sheet **2**.



**Installing lines**

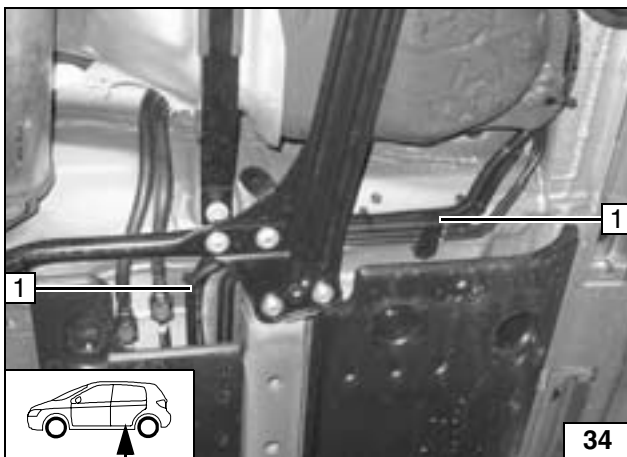

Insert the heater unit cable harness and metering pump cable harness in the Ø 10mm hose shaft **1**, place according to the illustration and secure with cable clips. Wrap the tube ends with insulation tape.



**Installing lines**

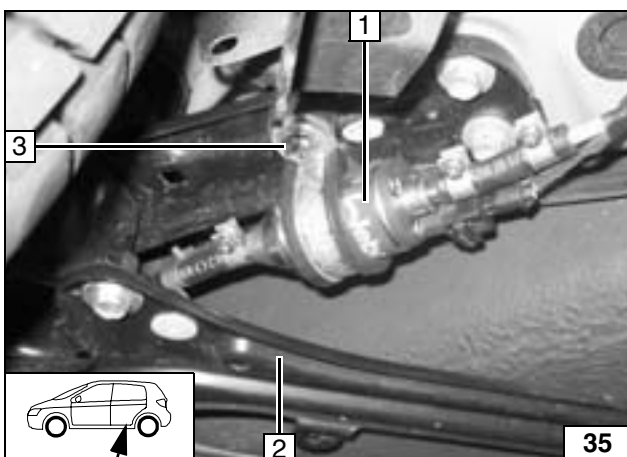

Remove the plastic cover from the bracket **2**, this will be used again. Check the position of the components; adjust if necessary. Check that these rotate freely.

- 1** Metering pump
- 3** Rubberized tube shaft, silentblock, flanged nut [2x], prepared bore hole



**Metering pump installation location**

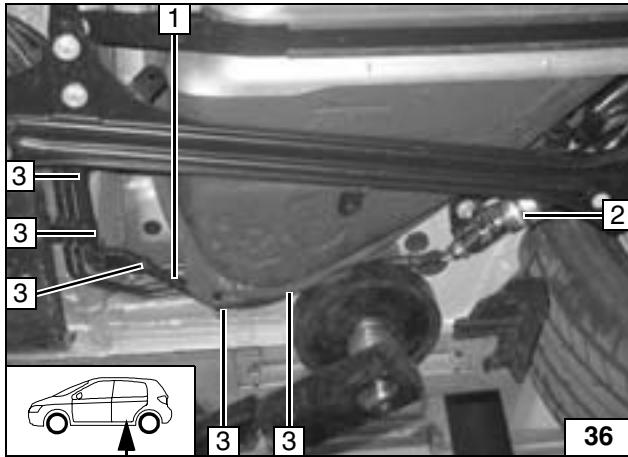

Insert the heater unit cable harness and metering pump cable harness in the Ø 10mm hose shaft **1**, according to the illustration, run to the metering pump installation location **2** and secure with cable clips **3**.



**Connecting to the metering pump**

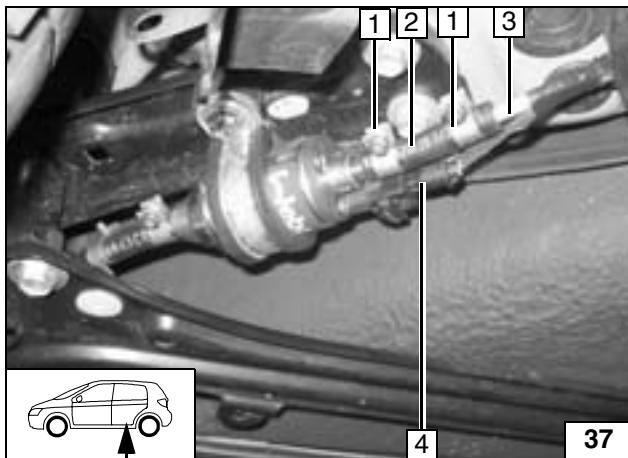

Fuel line from the heater unit **3** on the pressure side of the metering pump [side with connector].

- 1** Hose clamp Ø 10 mm [2x]
- 2** Hose section
- 4** Metering pump cable harness



**Connecting to the metering pump**

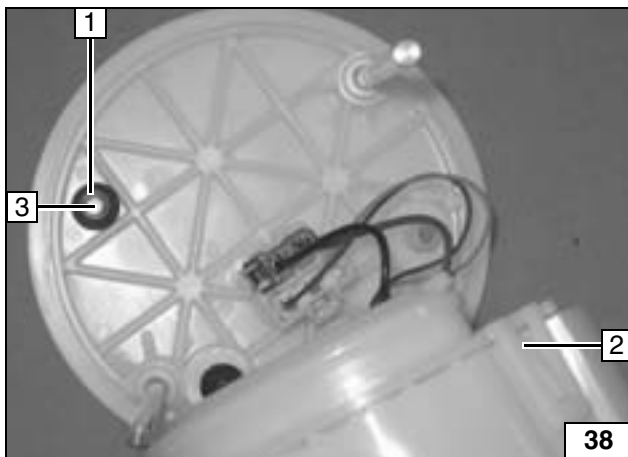

Remove the tank mounting **2** according to the manufacturer's instructions and take it apart.

Attach the M6 flanged nut **1** according to the illustration, transfer the hole image **3** for the Ø 6.0 mm hole.

Complete the tank mounting.



**Fuel take-off**

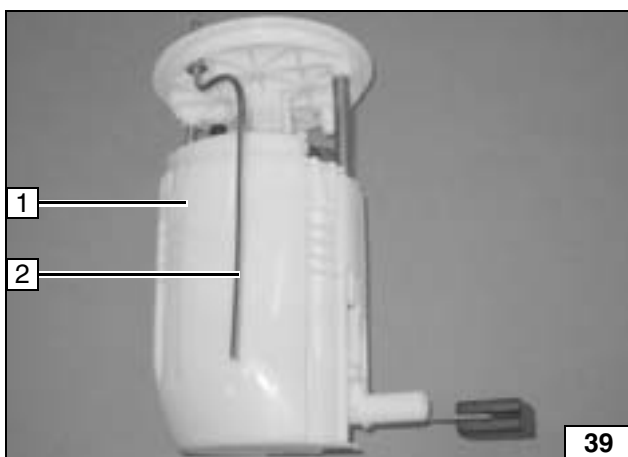

Shape, cut into sections, and insert the tank extracting device **2** according to the template, see the Installation Instructions.

- 1** Tank mounting



**Inserting tank extracting device**

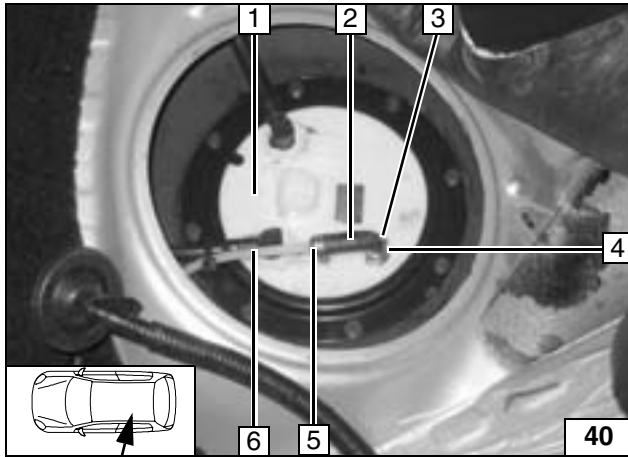

Install the tank mounting **1** according to the manufacturer's instructions. Shorten the moulded hose **2** by 10 mm for  $\varnothing$  3.5 mm.

- 3** Universal clip  $\varnothing$  8mm
- 4** Tank extracting device
- 5** Universal clip  $\varnothing$  10 mm
- 6** Enclosed 2000 long fuel line to the metering pump



**Fuel take-off**

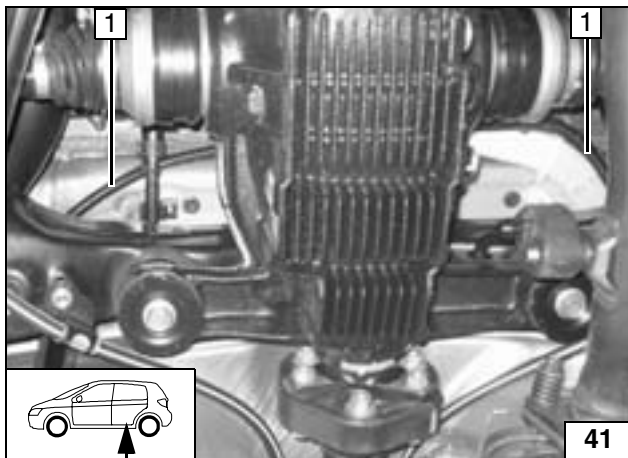

Insert the fuel line from the tank extracting device in the  $\varnothing$  10mm hose shaft **1** and run to the metering pump installation location, secure to existing lines with cable clips.



**Installing lines**

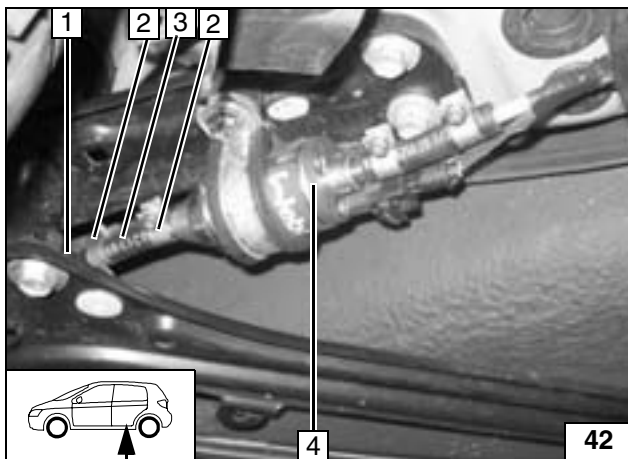

Fuel line **1** from the tank extracting device on the intake side of the metering pump **4** [side without connector].  
Cut fuel line into sections.

- 2** Hose clamp  $\varnothing$  10 mm [2x]
- 3** Hose section



**Connecting to the metering pump**

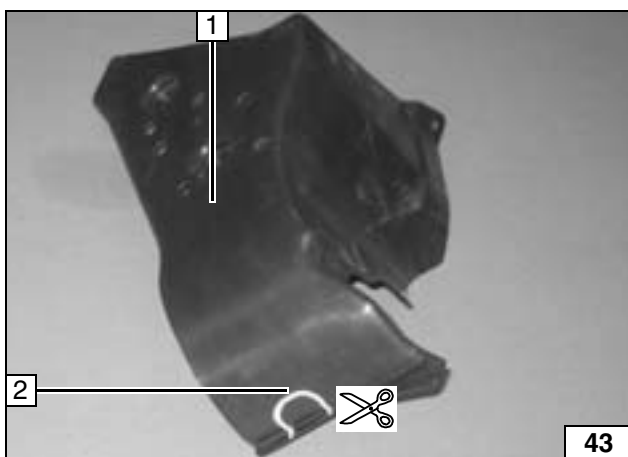

Cut out the underbody protection **1** on the marking **2** according to the illustration.



**Preparing the panelling**

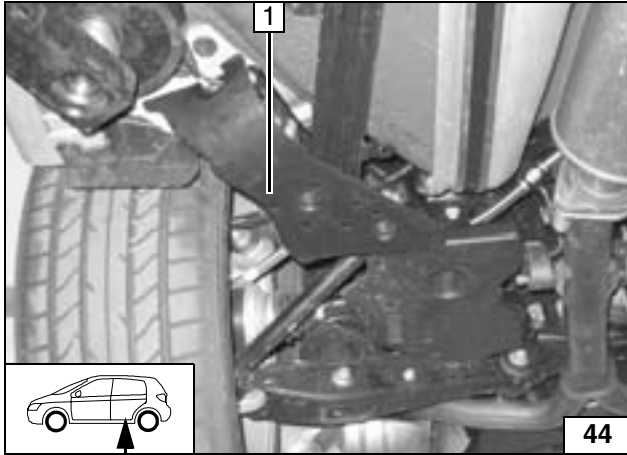

Re-assembling the panelling 1.



**Assembling the panelling**

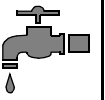

**Water Connection**

**WARNING!**

Tighten all hose clamps with 2.0 + 0.5 Nm.

Any coolant running off should be collected using an appropriate container.

Install hoses so that they are kink-free. Unless specified otherwise, always fasten using cable clips.

Position hose clamps and spring band clamps so that no other hose can be damaged.

The connection should be "inline" based on the following diagram:

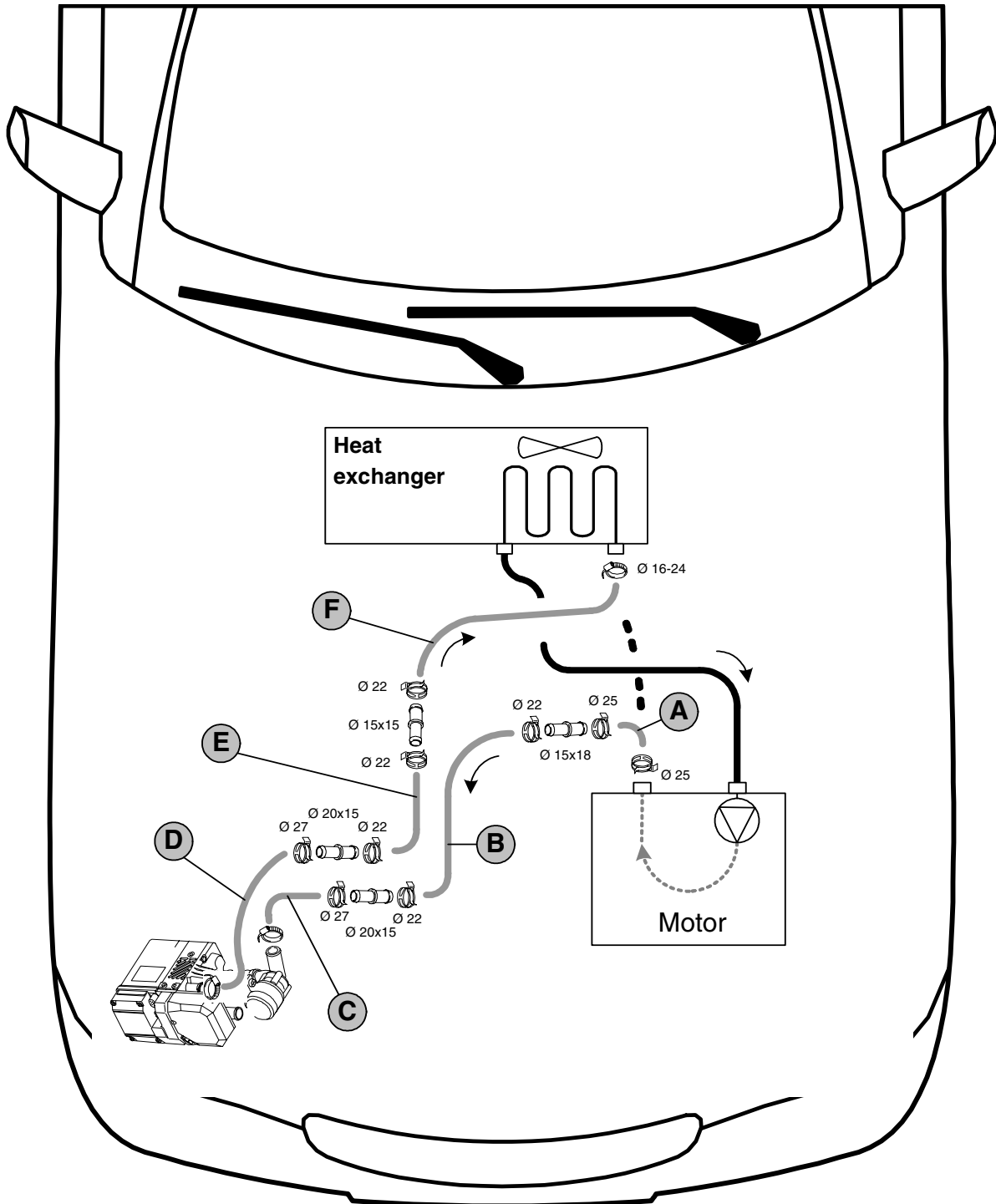

Water installation diagram

All undesigantated clamps are Ø 20-27 mm hose clamps.



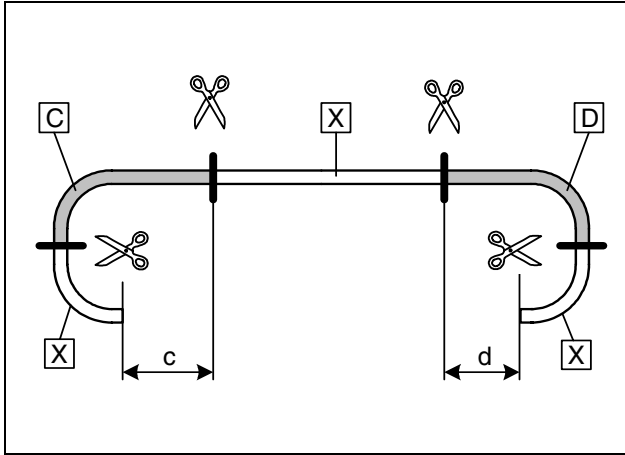
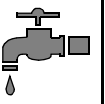

c = 310mm  
d = 280mm

Dispose of section X



**Cutting water hose into sections**

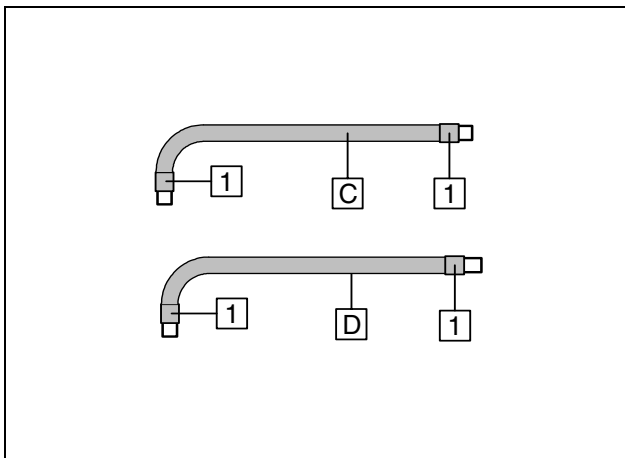

Cut the braided protective hose for hose C to 560 mm and insert.

Cut the braided protective hose for hose D to 380mm and insert.

Cut the heat shrink hose 1 into 25 mm pieces [4x] and shrink according to the illustration.



**Inserting braided protective hoses**

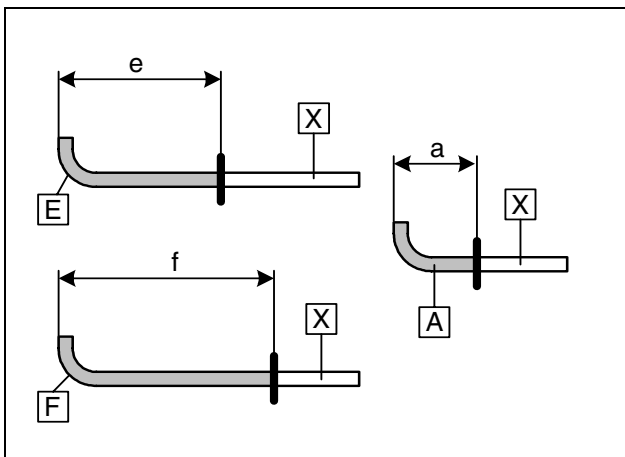

Cut the Ø 18mm moulded hose A into sections according to the illustration.

Cut the moulded hoses E and E into sections according to the illustration.

a = 70mm  
e = 440mm  
f = 860mm

The entire length of the Ø 15mm moulded hose B is used.

Dispose of section X



**Cutting water hose into sections**

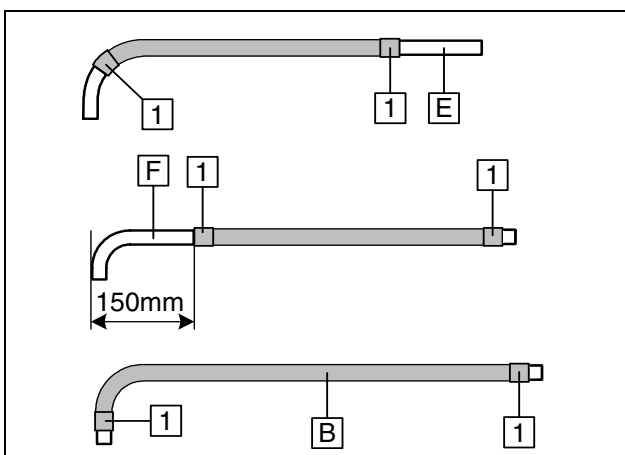

Cut the braided protective hose for hose E to 600mm and insert.

Cut the braided protective hose for hose F to 1,000mm and insert.

Insert the entire length of the braided protective hose for hose B.

Cut the heat shrink hose 1 into 25 mm pieces [6x] and shrink according to the illustration.



**Inserting braided protective hoses**

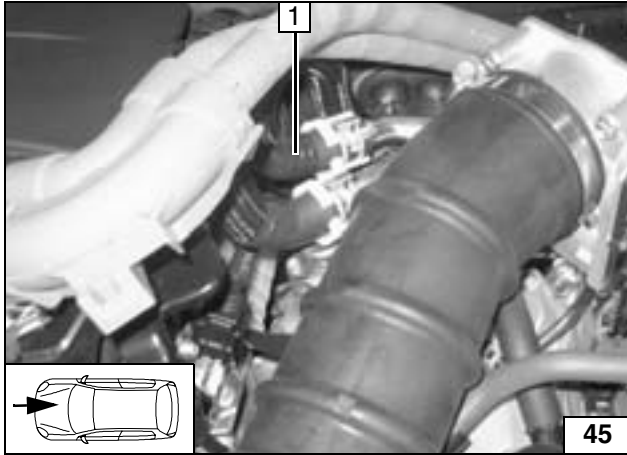

Remove the original vehicle engine moulded hose **1** from the engine exhaust to the heat exchanger inlet, the spring band clamps and moulded hose will no longer be needed.



**Splitting point**

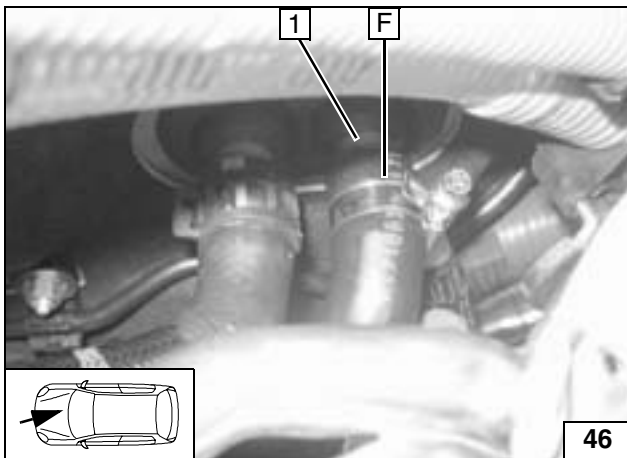

**1** heat exchanger inlet connecting piece

**Connecting to the heat exchanger inlet**

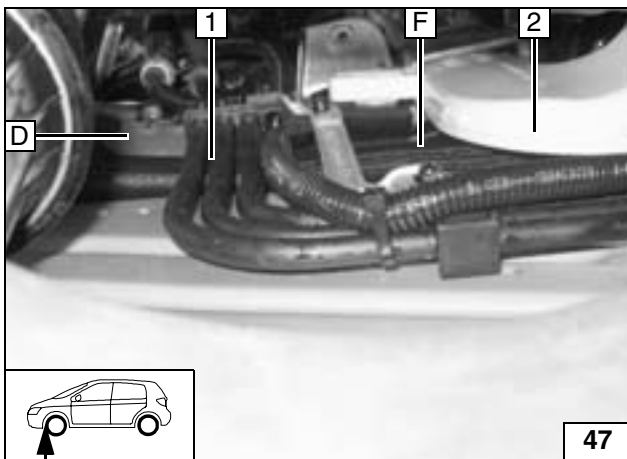

Position the hose **F** according to the illustration behind the original vehicle panelling **2** and lines **1**.



**Installing in the engine compartment**

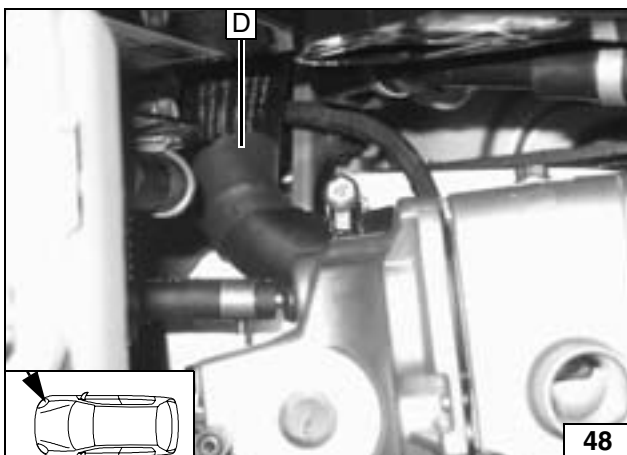

**Connecting to the heater unit**

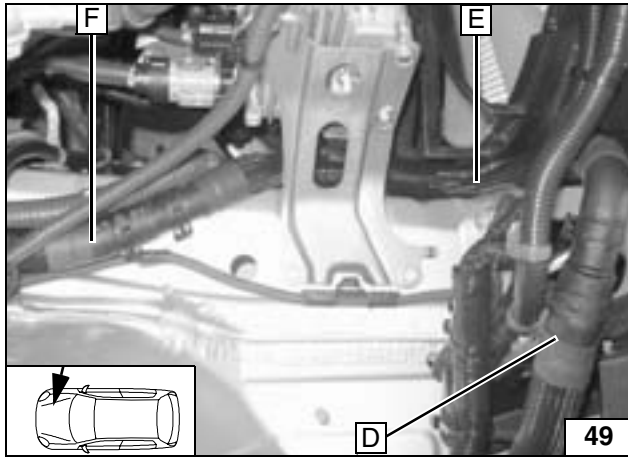

Placement  
in the  
engine  
compartment

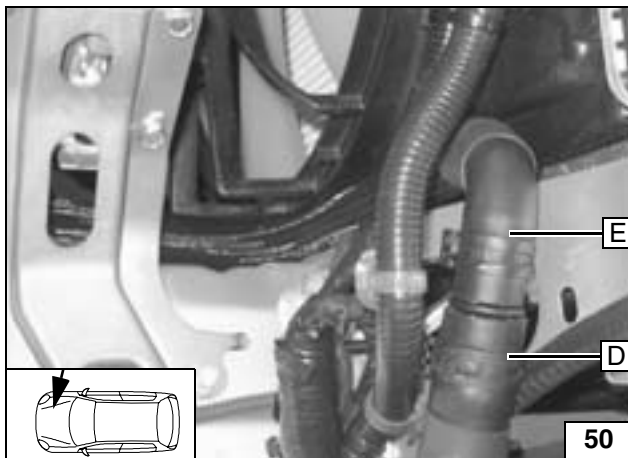

Placement  
in the  
engine  
compartment

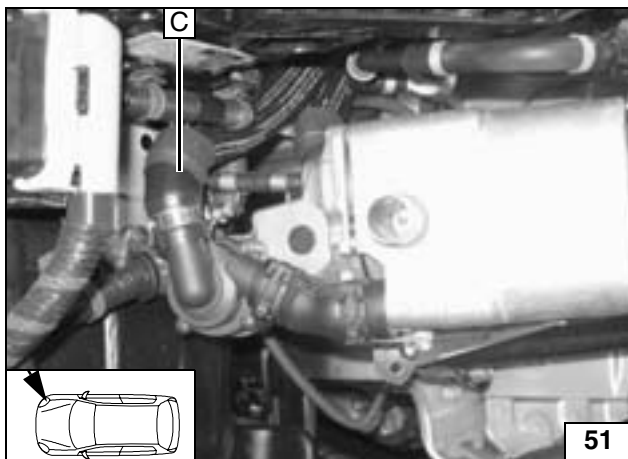

Connec-  
ting to the  
heater unit

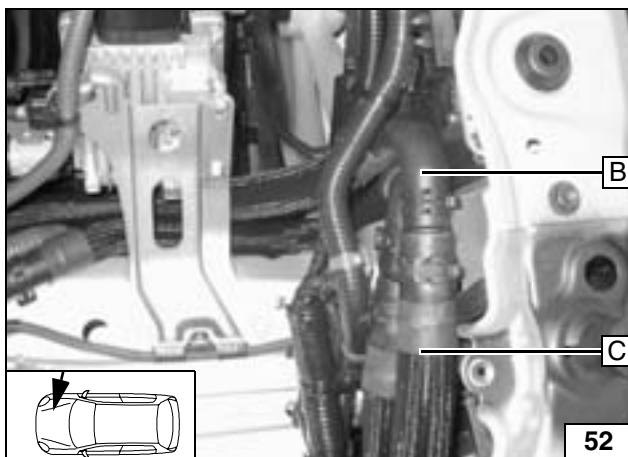

Installing  
in the  
engine  
compartment



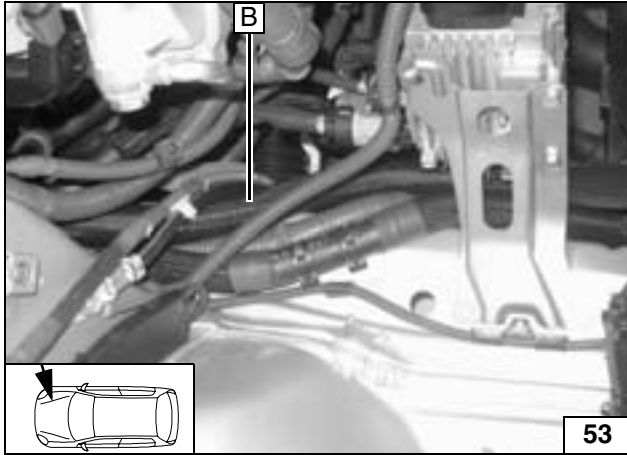

Placement  
in the  
engine  
compartment

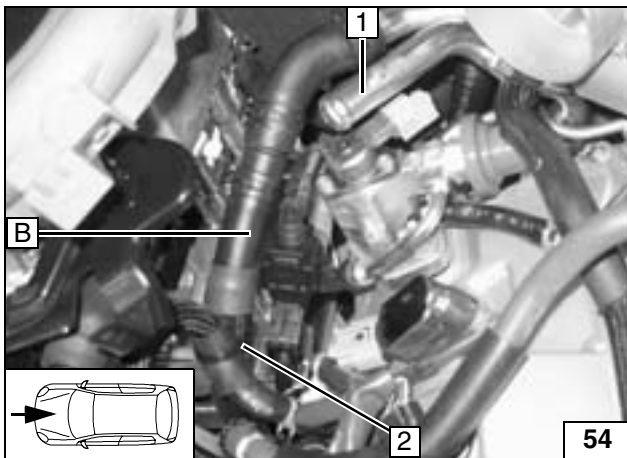

The moulded hose from the motor inlet **1** is only disassembled here as a demonstration.



**2** Cable clip

Connec-  
ting to the  
engine  
exhaust

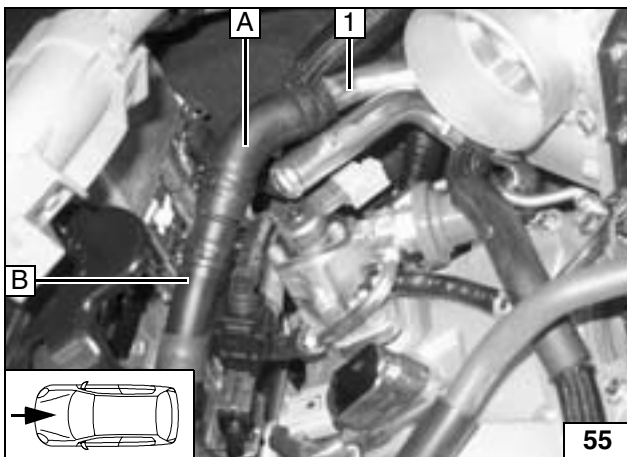

Before connecting, fill the water hoses with coolant.



**1** Engine exhaust hose

Connec-  
ting to the  
engine  
outlet

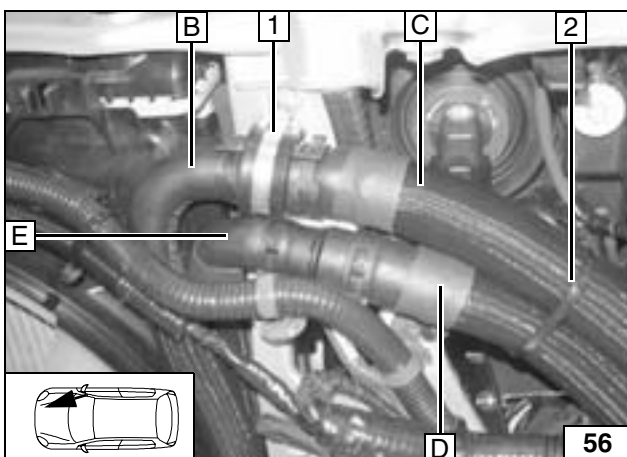

Assemble the rubberized  $\text{\O} 29\text{mm}$  tube shaft **1** to the original vehicle hole according to the illustration with M6x20 bolt and M6 flanged nut.



**2**  $\text{\O} 27\text{mm}$  cable clip

Assem-  
bling the  
rubberized  
tube clamp

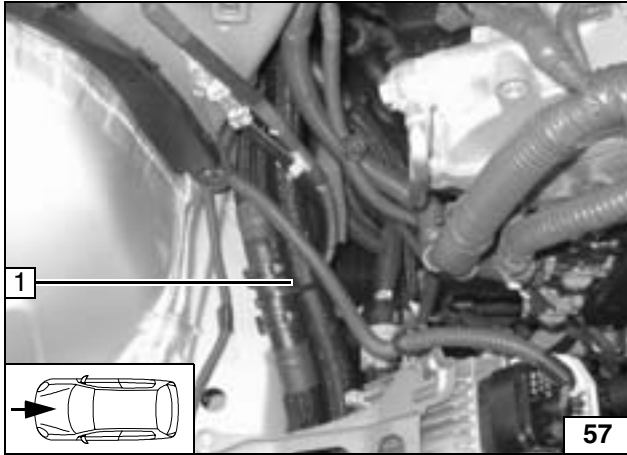

1 Cable clips

Placement  
in the  
engine  
compartment

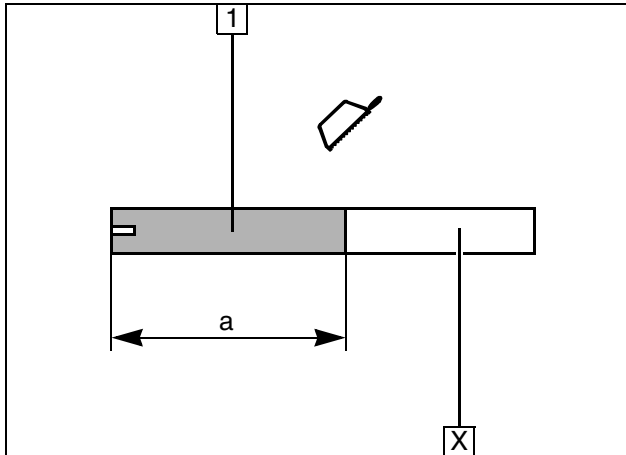

## Combustion Air

- 1 Combustion air pipe  
a = 280mm

Dispose of section X

**Cutting the combustion air pipe into sections**

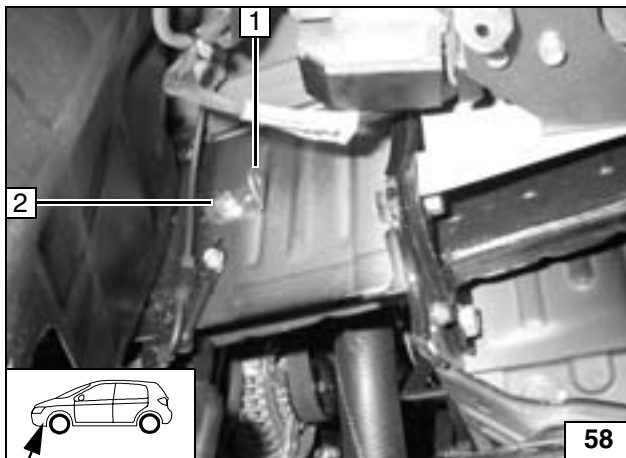

- 1 Angle bracket
- 2 Original vehicle stay bolts, M8 flanged nut

**Assembling the angle bracket**

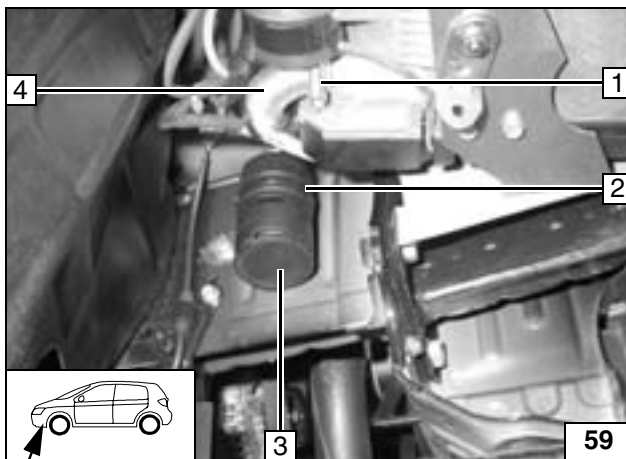

- 4 Combustion air intake pipe
- 1 Ø 27 mm hose clamp
- 3 Combustion air intake silencer
- 2 Cable clip



**Assemble the intake silencer**

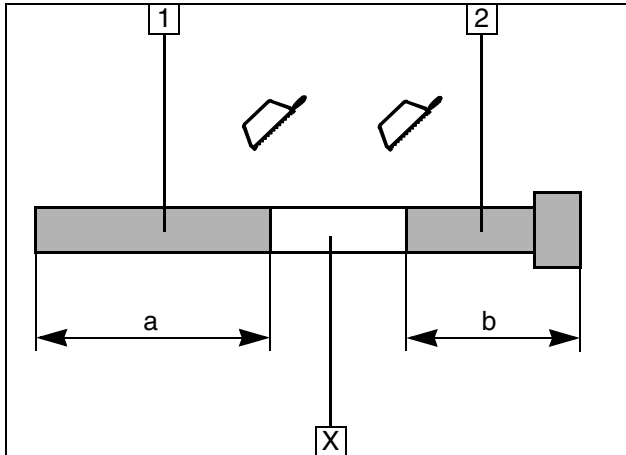
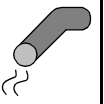

## Exhaust System

- 1 Exhaust pipe  
a = 280mm
- 2 Exhaust end section  
b = 280mm

Dispose of section X

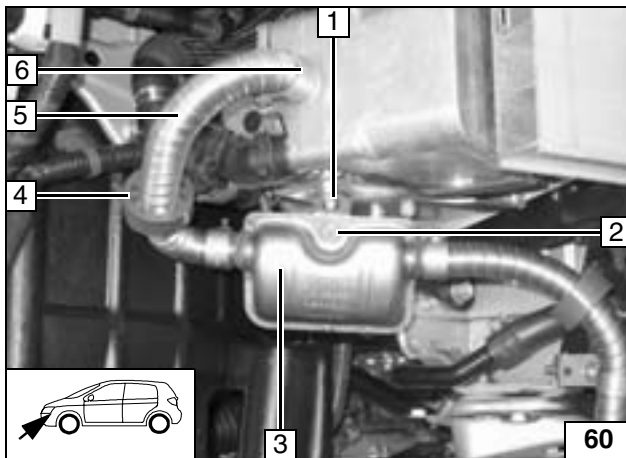

- 1 Angle bracket
- 2 M6x20 bolt, flanged nut M6
- 3 Exhaust silencer
- 4 Red (rt) rubber profile
- 5 Exhaust pipe
- 6 Hose clamp

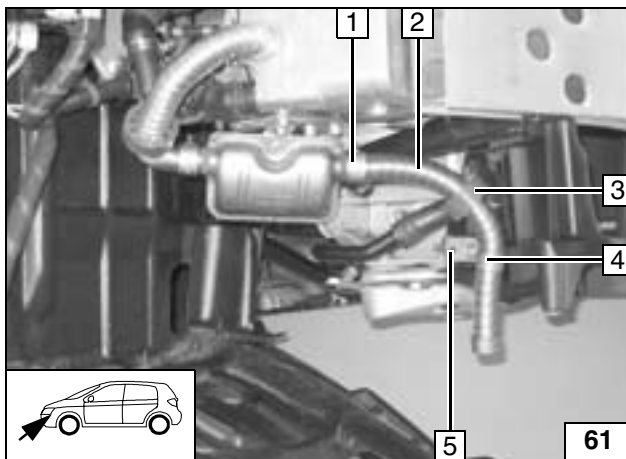

- 1 Hose clamp
- 2 Exhaust end section
- 3 Red (rt) rubber profile
- 4 Tube clamp, M6x20 bolt, flanged nut M6
- 5 Bracket, existing hole, M6x20 bolt, flanged nut M6

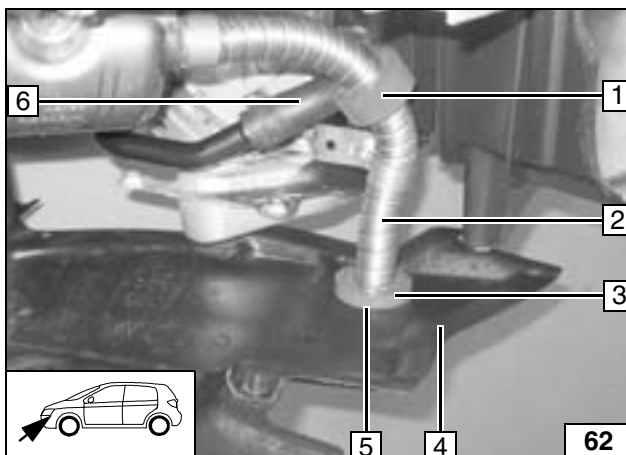

Drill  $\varnothing$  42mm hole 5 in the wheel-house panel 4 according to the illustration position, insert the red (rt) rubber profile with groove 3.

Align the red (rt) rubber profile 1 to the hose 6 according to the illustration.

- 2 Exhaust end section

Preparing the exhaust pipe

Assembling the silencer

Assembling the exhaust pipe



Inserting rubber profile

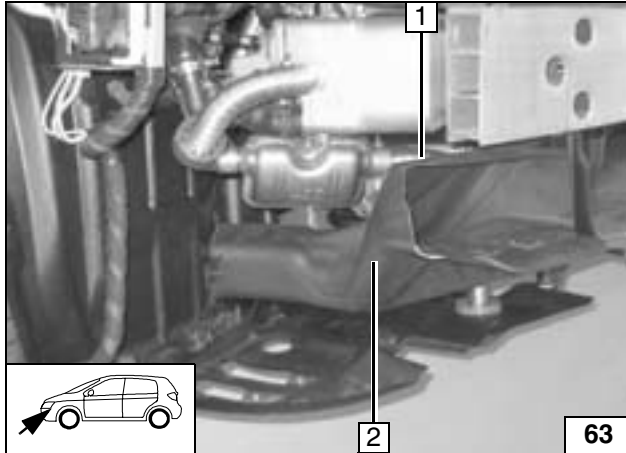
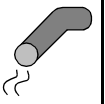

Assemble the **brake coolant air duct 2 !**

Align the red (rt) rubber profile on the exhaust line **1** to the ventilation channel and hose (page 28/62).

Ensure sufficient distance from adjacent components.



**Positioning the rubber profile**

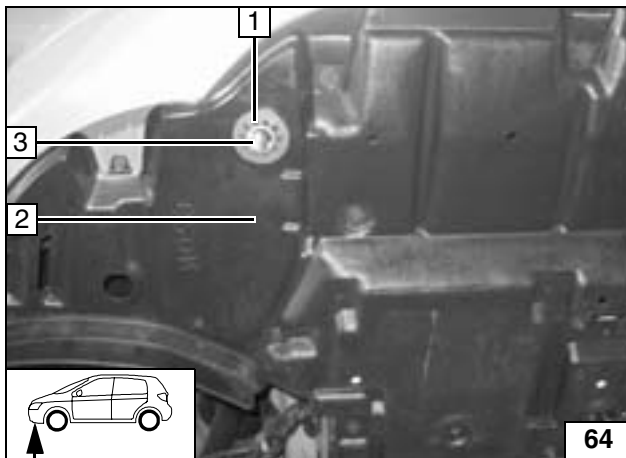

- 1 Red (rt) rubber profile with groove
- 2 Lower footwell cover
- 3 Exhaust end section

**Positioning the rubber profile**

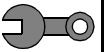

## Final Work

### WARNING!

Reassemble disassembled components in reverse order.

Check that all hose lines, clips, and all electrical connections are securely fastened.

Secure all loose lines using cable clip.

Only use manufacturer-approved coolant.

Spray heating unit components with anti-corrosion wax (Tectyl 100K, Order No. 111329).

- Connect battery.
- Fill and bleed the coolant circuit according to the vehicle manufacturer's specifications.
- Set the time switch.
- Set the manual air conditioning or automatic air conditioning according to the "operating instructions for the end customer".
- Check that the auxiliary heating operates properly, see operating instructions / installation instructions.
- Attach the "Switch off auxiliary heating before re-fuelling" sticker onto the left side of the B-pillar.



# Webasto

*Feel the drive*

Webasto AG  
Postfach 80 - 82132 Stockdorf - Hotline 0 18 05 / 93 22 78  
Hotfax (0395) 55 92-353 - <http://www.webasto.de>

**Operating instructions for the end customer**

Please remove page and add to the vehicle operating instructions.



Before parking the vehicle, make the following settings:

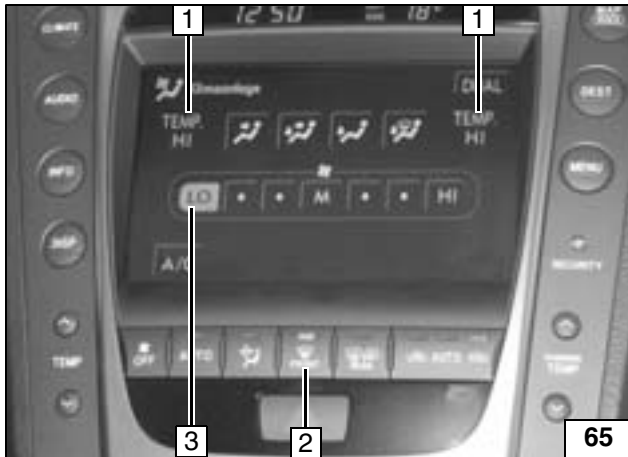

- 1 Temperature to "TEMP HI"
- 2 Air outlet to windscreen
- 3 Blower set to "LO" or "1"

For vehicles with automatic air conditioning

For short distance trips, it is not recommended that the rear window heating be used.

Rule of thumb for operating the auxiliary heating: driving time = heating time.

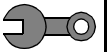

### Tank Extracting Device Template

