

Water Heater Unit



Feel the drive

Thermo Top E Additional Heater

00 0003

Thermo Top C Additional Heater

00 0002

Thermo Top P Additional Heater

00 0104

Installation Instructions

Toyota Hilux

Diesel

from Model Year 2005

For left-hand drive vehicles only



WARNING!

Hazard warning:

Incorrect installation or repair of Webasto heating systems may cause a fire or result in the emission of carbon monoxide, which can be fatal. Serious or fatal injuries can be caused as a result.

Specialist company training, technical documentation, specialized tools and equipment are required to install and repair Webasto heating and cooling systems.

NEVER attempt to install or repair Webasto heating or cooling systems if you have not successfully completed the company training and thereby acquired the required technical skills, or if you do not have access to the required technical documentation, tools and equipment needed to carry out correct installation and repairs.

ALWAYS follow all Webasto installation and repair instructions and observe all warnings.

Webasto does not accept any liability for defects and damage that are attributable to installation by untrained staff.

Table of Contents

Validity	2	Preparing installation location	9
Heater Unit/Installation Kit	3	Preparing heater unit	10
Foreword	3	Installing heater unit	11
General Instructions	3	Coolant connection	13
Special Tools	3	Combustion air	16
Explanatory Notes on Document	4	Fuel Connection	17
Preliminary Work	5	Exhaust system	19
Heater unit installation location	5	Final Work	22
Electrical Connections	6	Operating Instructions for End Customer	23
Fan controller	7	Template 01:	24
Digital Timer and		Template 02:	25
Summer/winter switch option	8		
Remote option (Telestart)	8		

Validity

Manufacturer	Model	Type	ABE No.
Toyota	Hilux	N15	L641
Toyota	Hilux	MT	L643
Toyota	Hilux	N25S	L642*01

Engine type	Engine model	Output in kW	Displacement in cm ³
2KD-FTV	Diesel	75	2494
1KD-FTV	Diesel	126	2982

Vehicle and engine types and equipment variants not listed in these installation instructions have not been tested. However, installation according to these installation instructions may be possible. The installation location of a digital timer and summer/winter switch should be confirmed with the end customer before installation.

Heater Unit/Installation Kit

Quantity	Description	Order No.:
1	Retail accessories with desired heater control	See price list
1	Installation kit for Toyota Hilux Diesel	1310483B

Heater unit recommended for the respective vehicle class:

Vehicle	Heater unit
Compact car	Thermo Top E
Mid-size car, station wagon	Thermo Top C
Full-size car, van, offroader	Thermo Top P

The selection of the heater unit is based on the passenger compartment size of the vehicle and the level of comfort required by the customer!



Foreword

The installation instructions apply to the Toyota Hilux vehicles with a Diesel engine
 - For the validity, see page 2 - from model year 2005 and later, assuming technical modifications to the vehicle do not affect installation, any liability claims excluded. Depending on the vehicle version and equipment, modifications may be necessary during installation with respect to these installation instructions.

However, the stipulations in the "installation instructions" and "operating and maintenance instructions" for the *Thermo Top C/P/E* must always be observed.

The corresponding rules of technology and any information from the vehicle manufacturer should be observed during the installation work.

General Instructions

Installation should be carried out according to the general, standard rules of technology. Unless specified otherwise, fasten hoses, lines and wiring harnesses to original vehicle lines and wiring harnesses using cable ties.

Sharp edges should be fitted with edge protectors (split-open plastic hose).

Spray unfinished body areas, e.g. drilled holes, with anti-corrosion wax (Tectyl 100K, Order No. 111329).

Special Tools

- Torque wrench for 2.0 - 10 Nm
- Hose clamping pliers
- Metric thread-setter kit

Explanatory Notes on Document

To provide you with a quick overview of the individual working steps, you will find an identification mark on the outside top right corner of the page in question.

Mechanical system



Electrical system



Coolant connection



Fuel connection



Exhaust system

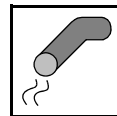

Combustion air



Special features are highlighted using the following symbols:



Specific risk of injury or fatal accidents.



Specific risk of damage to components.



Specific risk of fire or explosion.



Reference to general installation instructions of Webasto components or to the manufacturer's vehicle-specific documents.



Reference to a special technical feature.

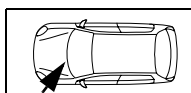
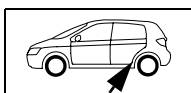

The arrow in the vehicle icon indicates the position on the vehicle and the viewing angle.

Preliminary Work

WARNING!

- Disconnect both batteries.
- Depressurize the cooling system.
- Copy the factory number from the original type label to the duplicate type label.
- Remove years that do not apply from the duplicate label.
- Attach the duplicate label (type label) in the appropriate place.
- Completely remove the battery on the right.
- Remove the coolant reservoir cap on the right.
- Open the fuse and relay box.
- Open fuel tank cap, ventilate tank
- Close the tank cap again.
- Remove the lower instrument panel trim on the left.
- Remove page 22 "Operating Instructions for End Customer" and add the operating instructions

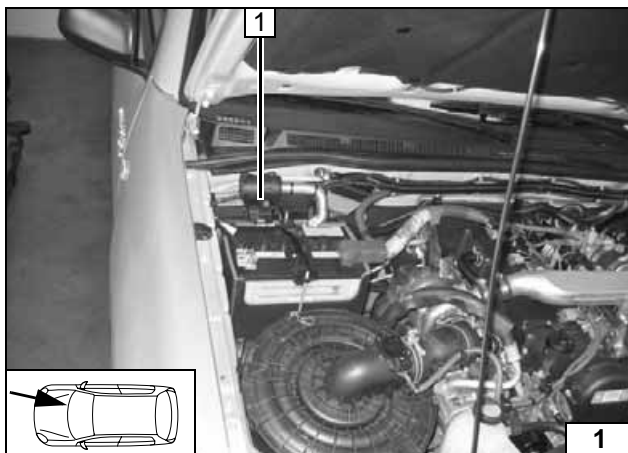

Heater unit installation location

- 1 Heater unit

Installation
location



Electrical Connections

Right-hand wiring harness pass through

- 1 Protective rubber plug
- 2 Wiring harness of fan controller

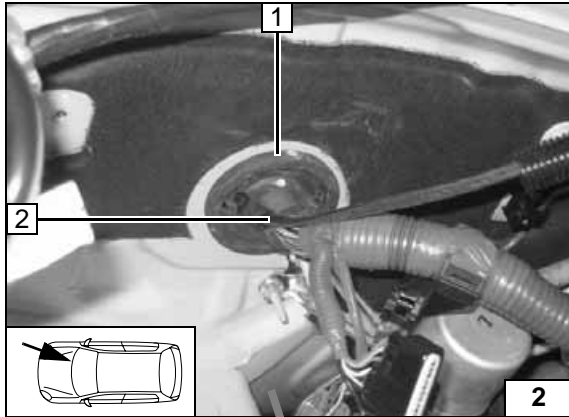

Installing wiring harness in engine compartment

- 1 Included corrugated tube with wiring harness and mecanyl fuel line

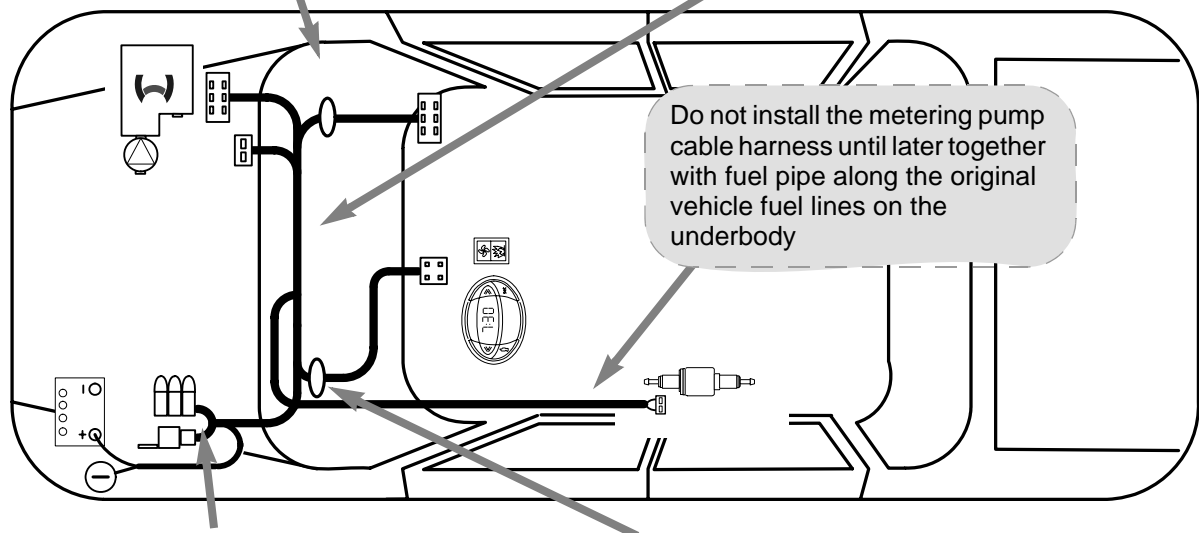
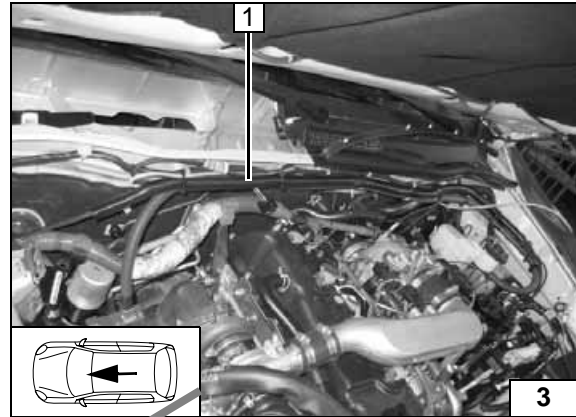

Wiring harness installation diagram

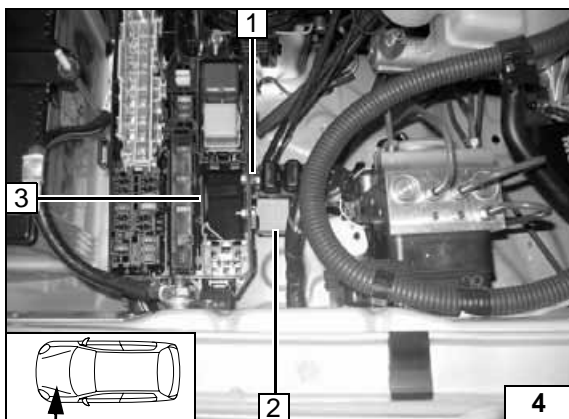

Fuse holder, relay K3

- 1 Retaining plate for fuse holder, 5.5 mm dia. hole, M5x12 bolt, washer, M5 flanged nut
- 2 K3 relay, 5.5 mm dia. hole, M5x12 bolt, M5 flanged nut
- 3 fuse and relay box in engine compartment

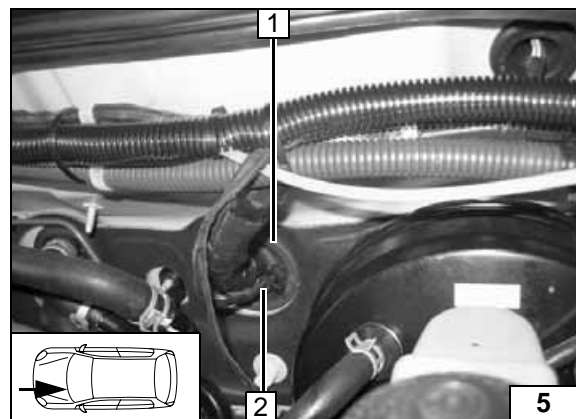

Left-hand wiring harness pass through

- 1 Protective rubber plug
- 2 Wiring harness of heater control

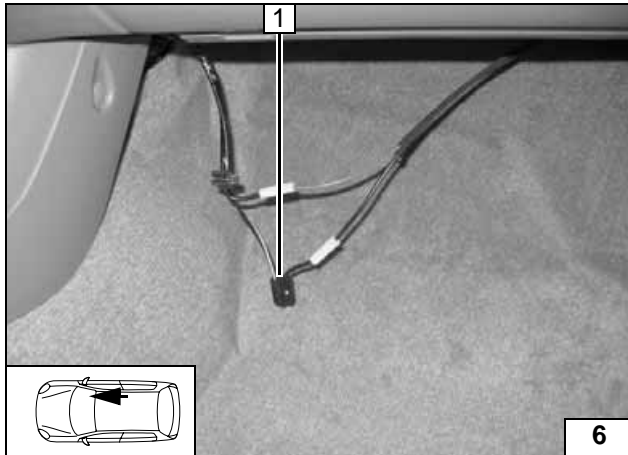

Fan controller

Connection to 2-pin connector from blower motor.
Make connections as shown in the wiring diagram with the tab receptacles provided.

1 2-pin connector



Connect-
ing fan mo-
tor

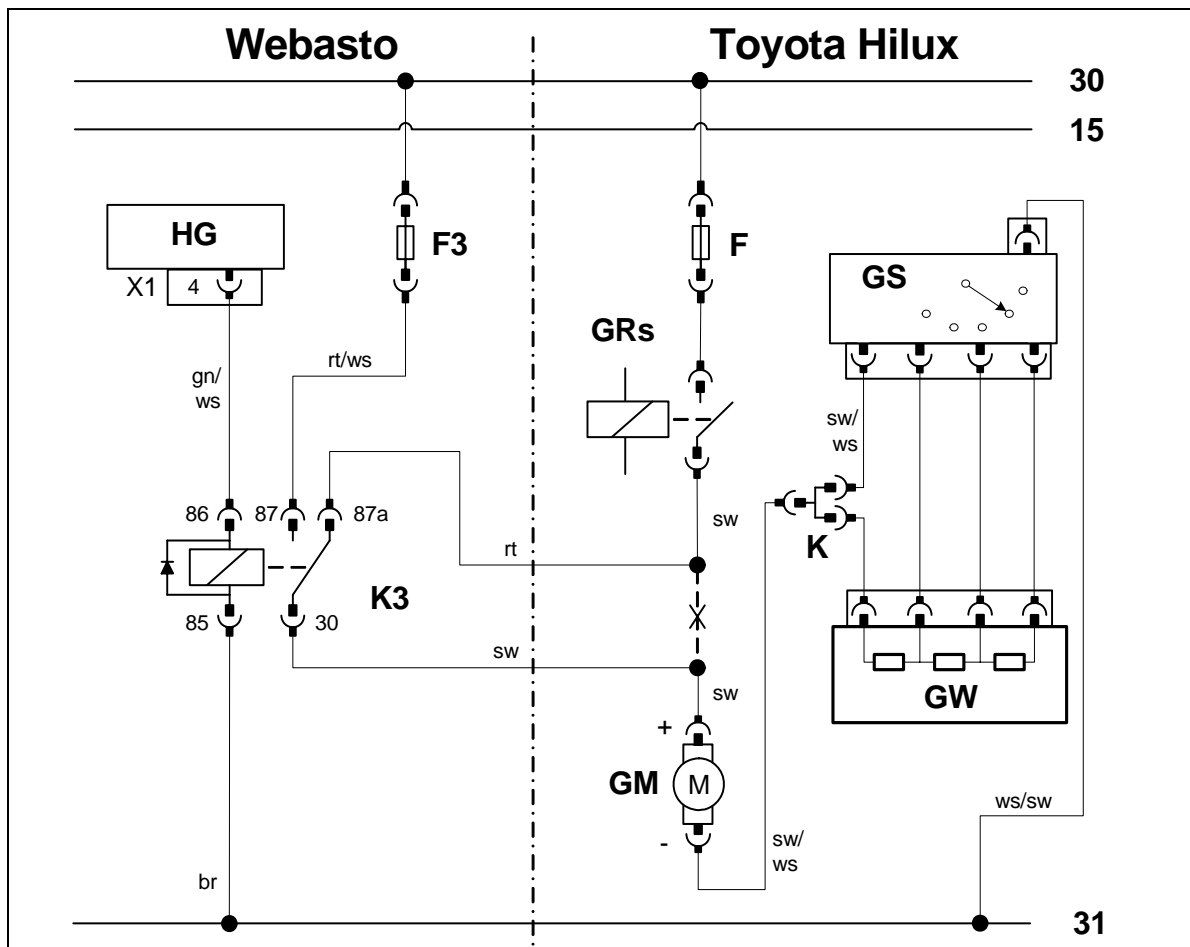

Wiring
diagram

Webasto components		Toyota Hilux components		Colors and symbols	
HG	Heater unit TT-C/E	GM	Fan motor	rt	red
F3	25 A fuse	GS	Fan switch	ws	white
K3	Fan relay	GW	Fan resistor	sw	black
		GRs	Fan relay	br	brown
		F	HTR 40 A fuse	gn	green
		K	Cable connector J18/J19		
				!	Insulate wire ends and tie back
				X	Cutting point

Legend

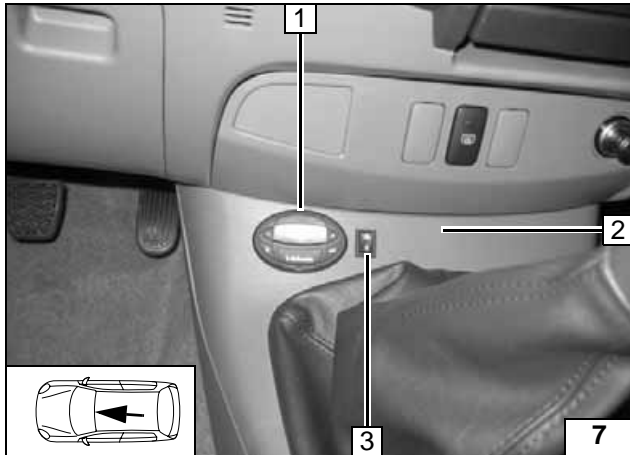

Digital Timer and Summer/winter switch option

- 1 Digital timer
- 2 Center console
- 3 Summer/winter switch



Installing digital timer

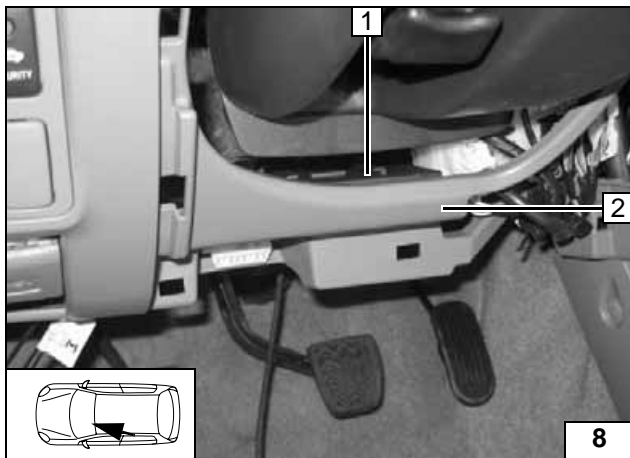

Remote option (Telestart)

- 1 Receiver, included self-adhesive Velcro strip
- 2 Lower instrument panel trim on left



Installing receiver

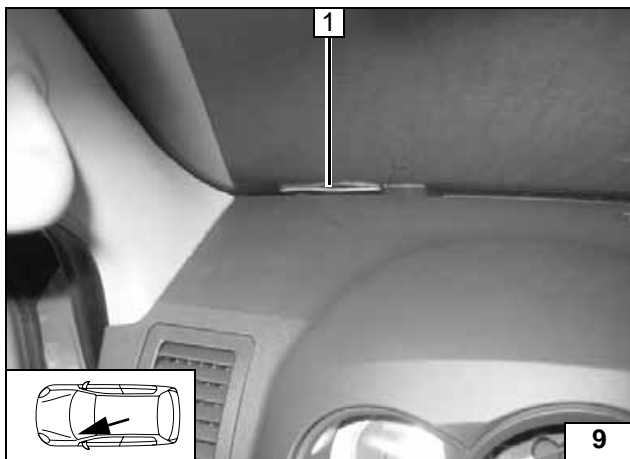

- 1 Antenna

Installing antenna

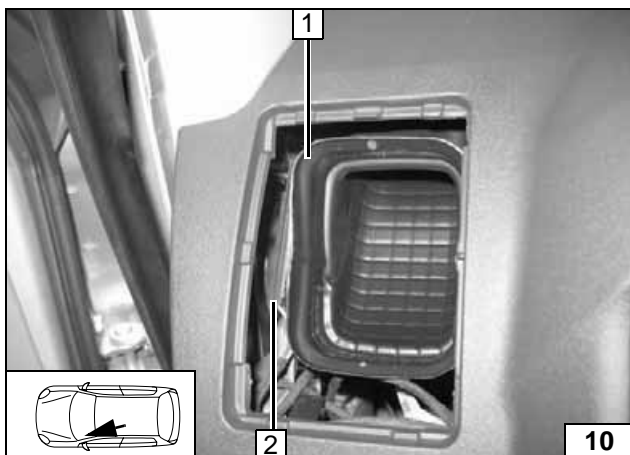

Only with Telestart T100 HTM

- 1 Ventilation duct on left
- 2 Temperature sensor, included self-adhesive Velcro strip

Installing temperature sensor

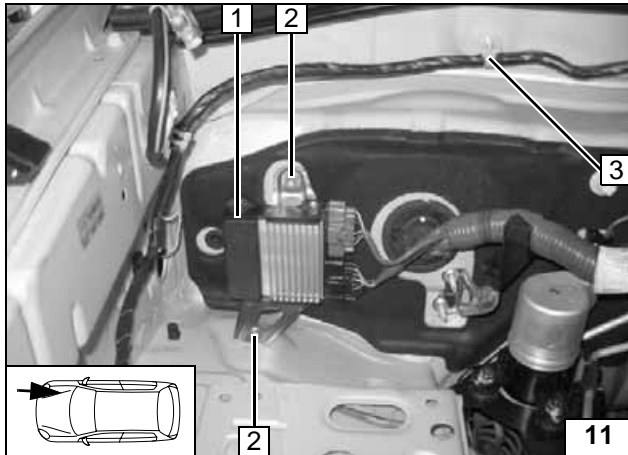
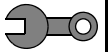

Preparing installation location

- 1 Original vehicle control unit
- 2 Original vehicle M6 bolt [2x] will be reused
- 3 Pull clip off bolt



Removing control unit

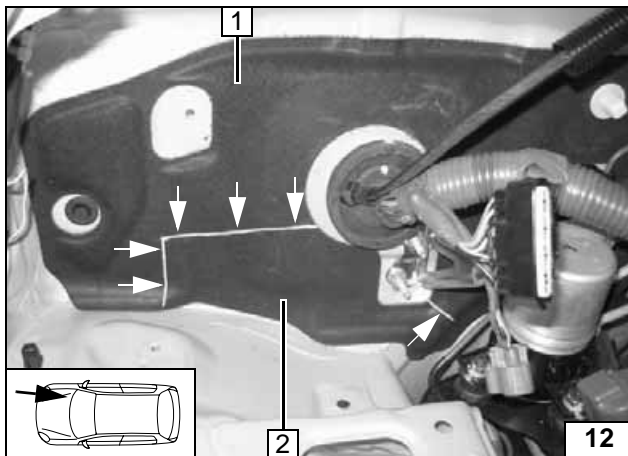

- 1 Original vehicle insulating mat
- 2 Discard section

Cutting out insulating mat

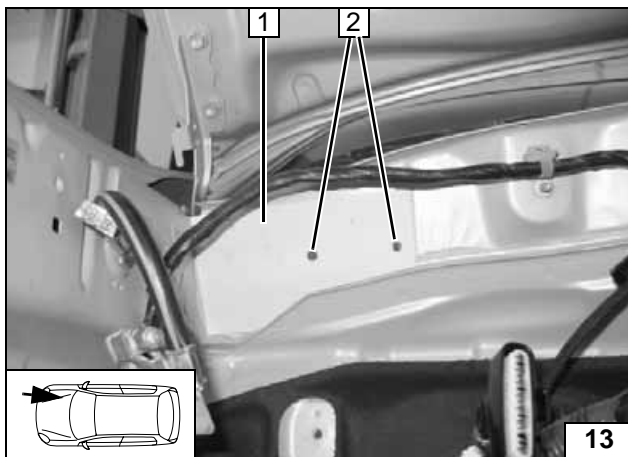

- 1 Cut out template and lay on
- 2 Copy hole pattern, 7 mm dia. hole [2x]

Copying hole pattern

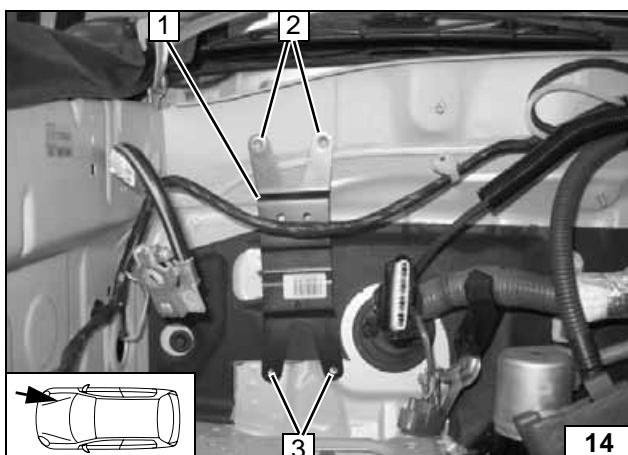

- 1 Loosely mount bracket
- 2 Original vehicle M6 bolt [2x], M6 flanged nut [2x]
- 3 Copy hole pattern [2x]
Remove bracket, drill 9.1 mm dia. hole [2x], install rivet nuts [2x]

Copying hole pattern

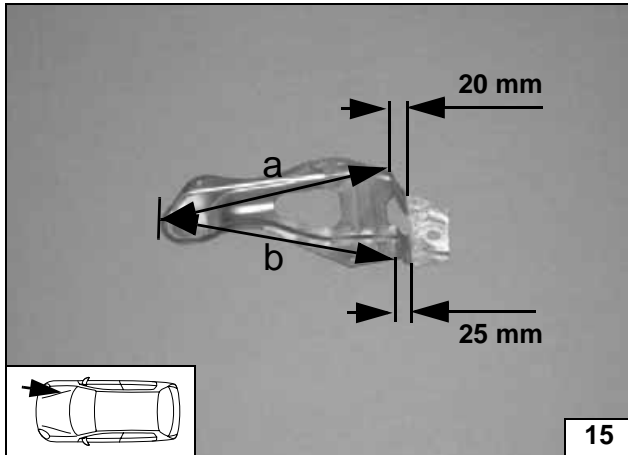
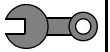

Smooth bracket of control unit on 90° elbow and mold according to template!

a = 170 mm
b = 175 mm



Molding bracket of control unit

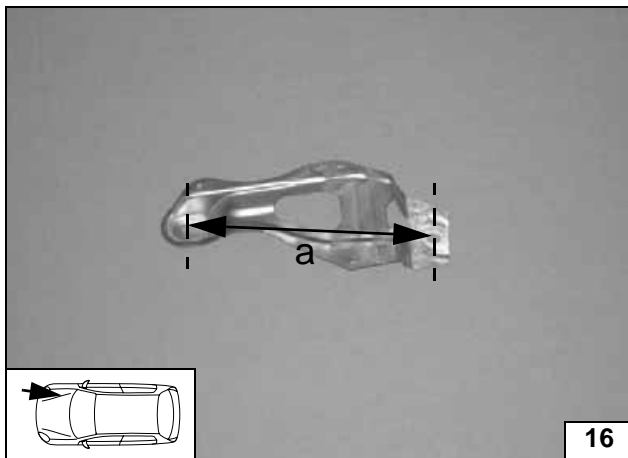

Following molding, dimension **a** between two holes must be checked.

a = 170 mm



Molding bracket of control unit

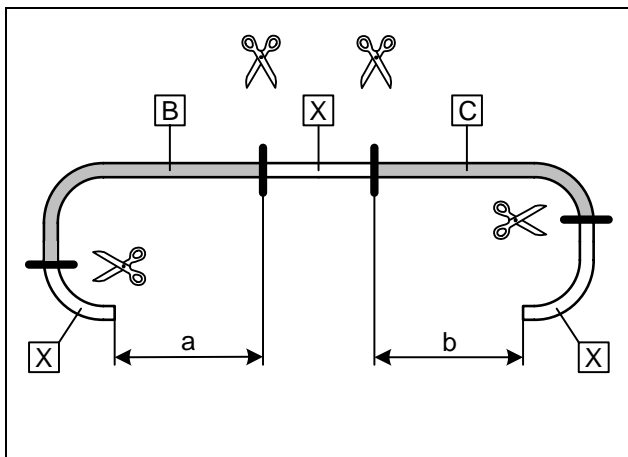

Preparing heater unit

a = 600 mm
b = 600 mm
Discard section **X**



Cutting coolant hoses to length

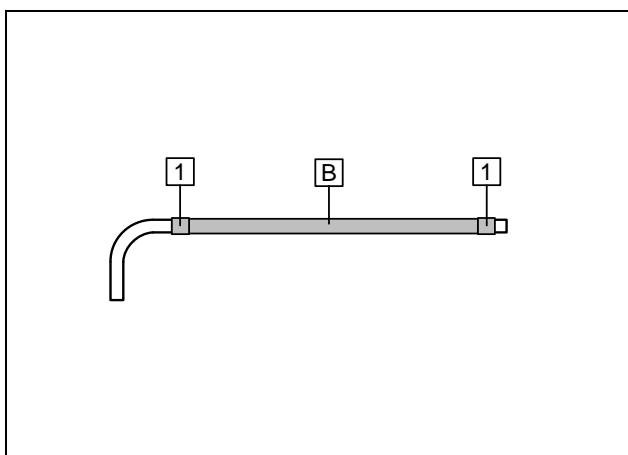

Cut braided protection hose to length and push onto hose **B**. Cut heat shrink plastic tubing in half, push on and shrink.

1 Heat shrink plastic tubing cut in half



Preparing coolant hoses

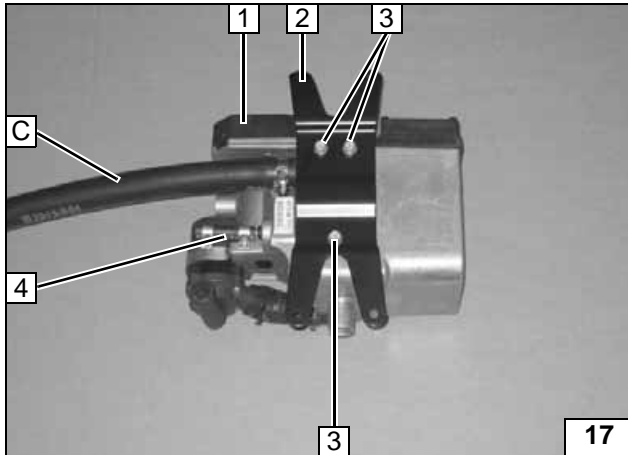
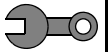

Tighten EJT screws to 10 Nm!
Bend bracket according to template.

- 1 Heater unit
- 2 Bracket
- 3 Ejt screw [3x]
- 4 Hose section, 10 mm dia. hose clamp [2x]
- C Hose on heater unit water outlet

Premounting heater unit

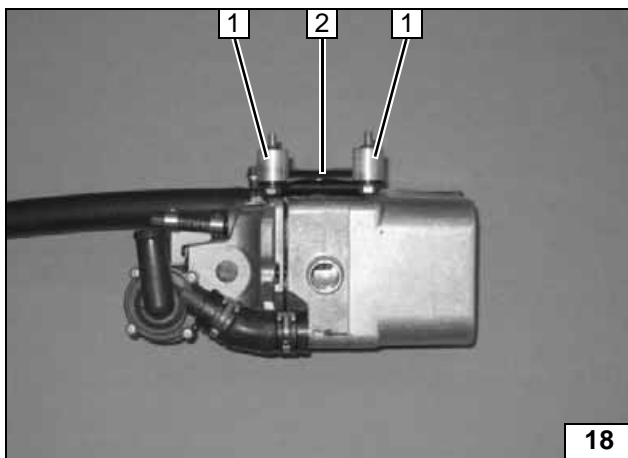

- 1 M6x35 bolt [2x], spring lockwasher [2x], 20 mm spacer [2x], pin lock [2x]
- 2 Bracket

Premounting heater unit

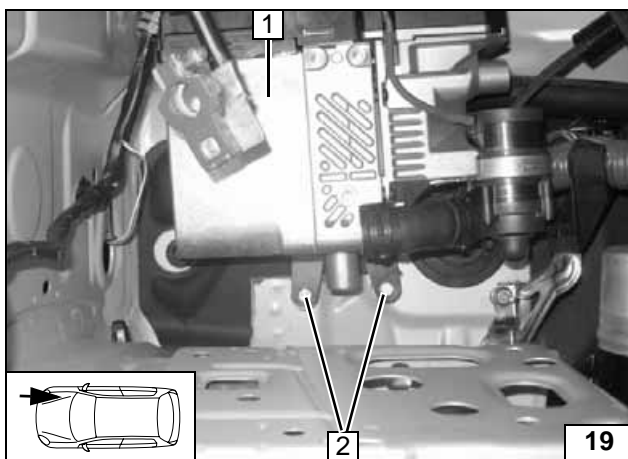

Installing heater unit

- 1 Heater unit
- 2 Premounted M6x35 bolt [2x] in M6 rivet nut [2x]

Installing heater unit

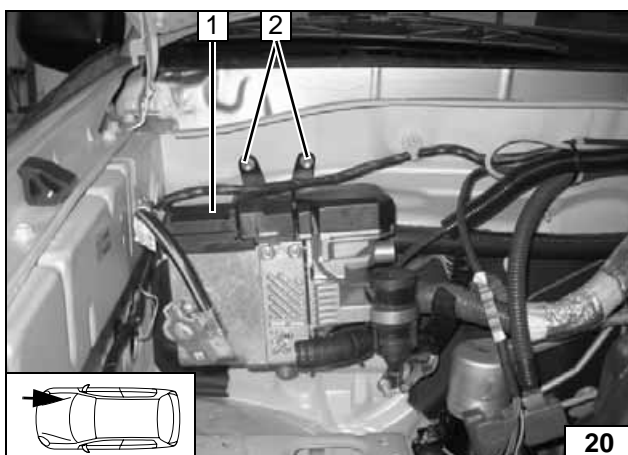

- 1 Heater unit
- 2 Original vehicle M6 bolt [2x], large diameter washer [2x], flanged nut [2x]

Installing heater unit

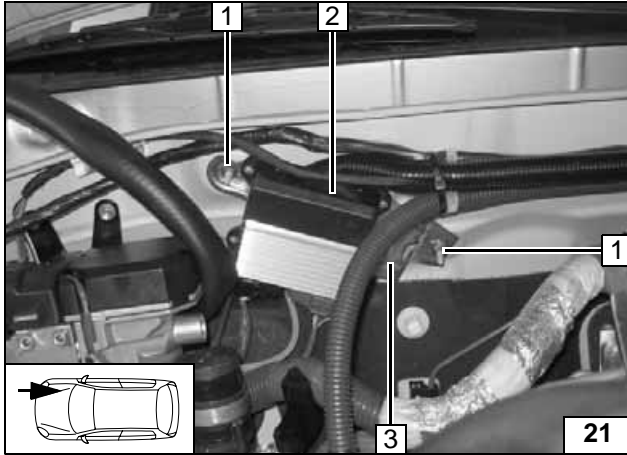
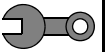

Check position of all components and adjust if necessary. Check that they have free clearance.

- 3 Molded bracket of control unit
- 2 Control unit
- 1 Original vehicle M6 bolt [2x], M6 flanged nut [2x]



Installing control unit



Coolant connection

WARNING!

Tighten all hose clamps to 2.0 + 0.5 Nm.

Any cold water running off should be collected using an appropriate container!

Install hoses so that they are kink-free. Unless specified otherwise, always fasten using cable ties.

Position hose clamps and spring band clamps so that no other hose can be damaged.

The connection should be "inline" based on the following diagram:

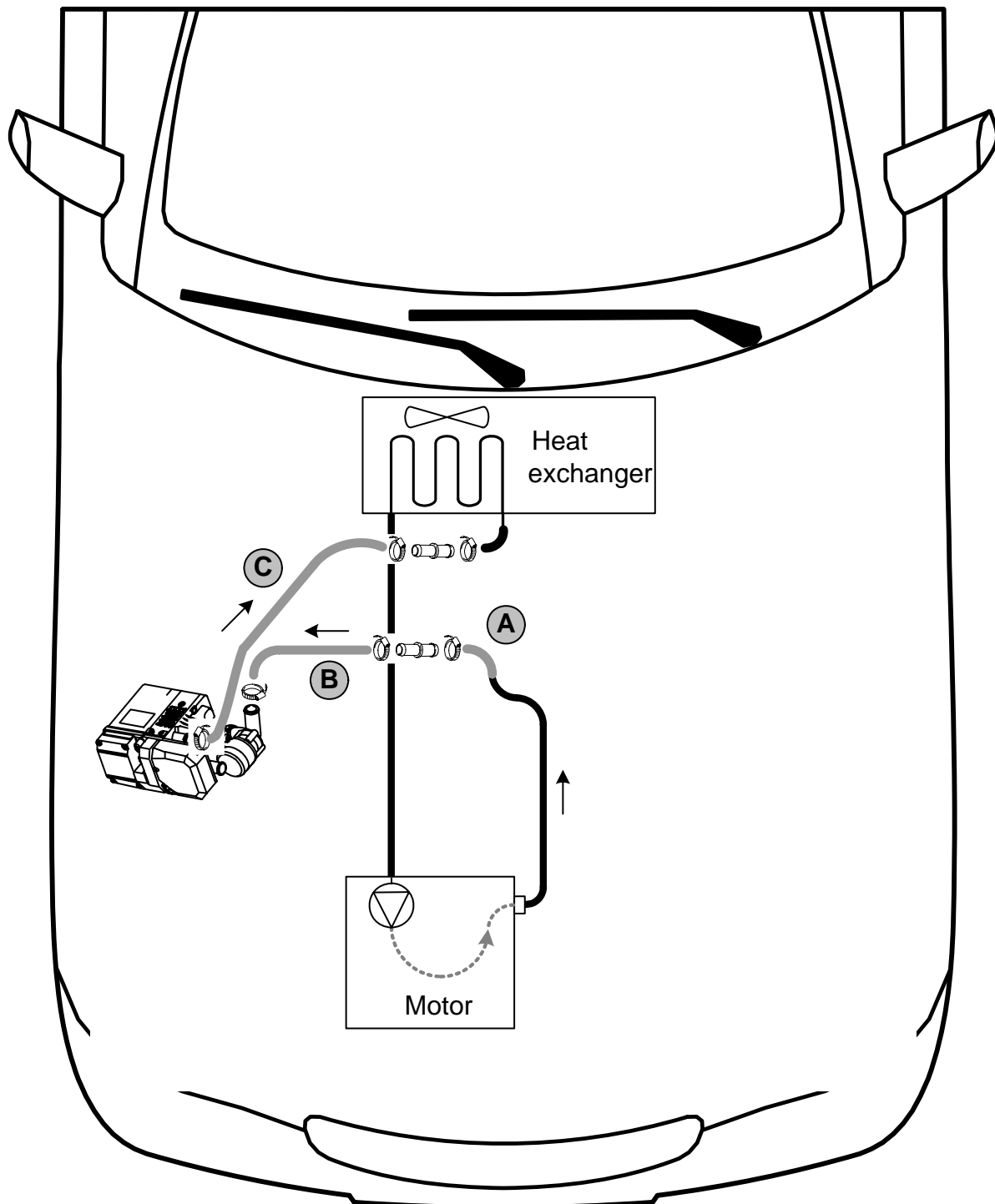

Coolant routing diagram

All clamps without a specific designation are 20-27 mm dia. hose clamps
All connecting pipes are 18x20 dia.



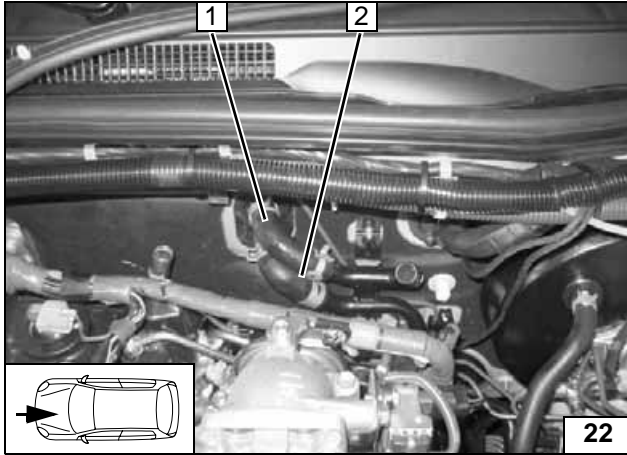

Remove coolant hose. Hose and original vehicle hose clamps will be reused.

- 1 Hose between heat exchanger outlet and engine inlet
- 2 Hose between engine outlet and heat exchanger inlet



Preliminary Work

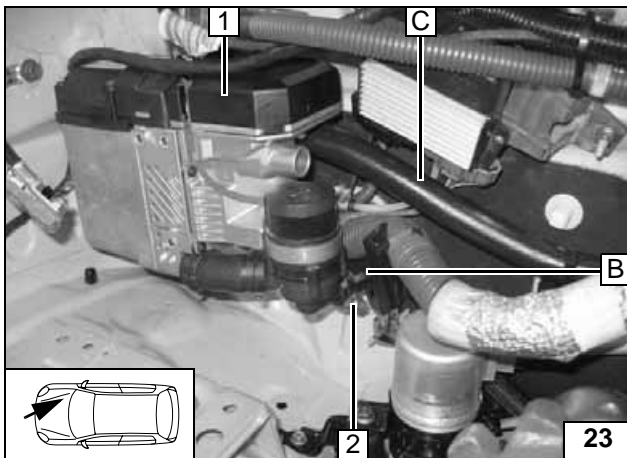

- 1 Heater unit
- 2 27 mm dia. hose clamp

Connection on heater unit

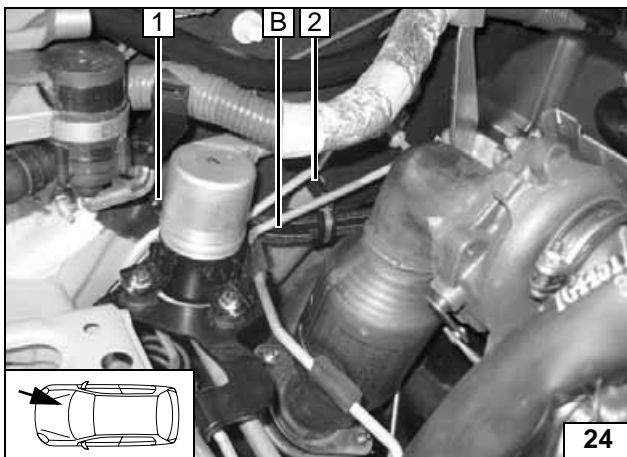

- 1 Black (sw) rubber profile
- 2 Original vehicle M6 bolt, 40 mm spacer nut, 29 mm rubber-coated p-clamp, spring lockwasher, M6 flanged nut

Routing in engine compartment

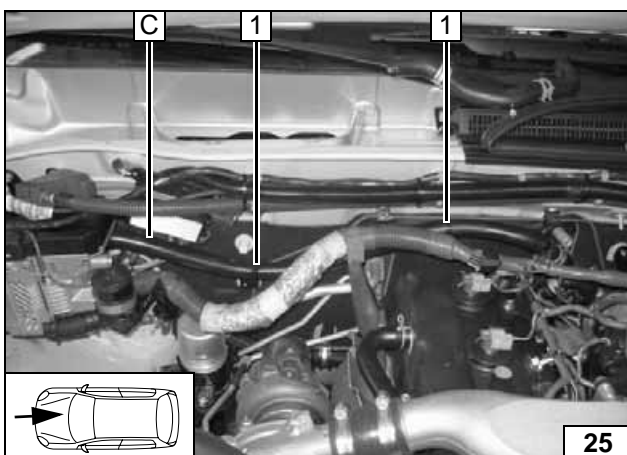

- 1 Cable tie [2x]

Routing in engine compartment

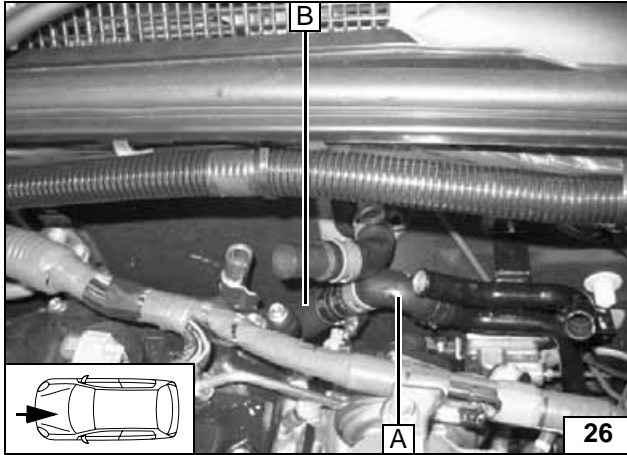

Before connecting, fill the water hoses with coolant.

A Included molded hose with 90° elbow on line of engine outlet



**Conne-
tion on en-
gine outlet**

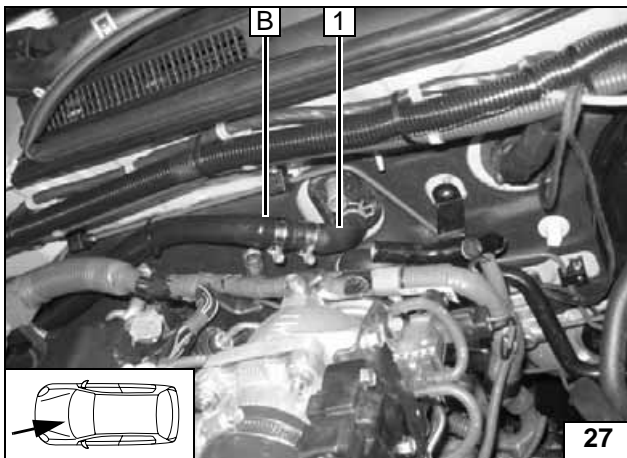

Original vehicle 90° elbow **1** turned by 180° and shortened by 20 mm on side of heat exchanger inlet.



**Conne-
tion on
heat ex-
changer in-
let**

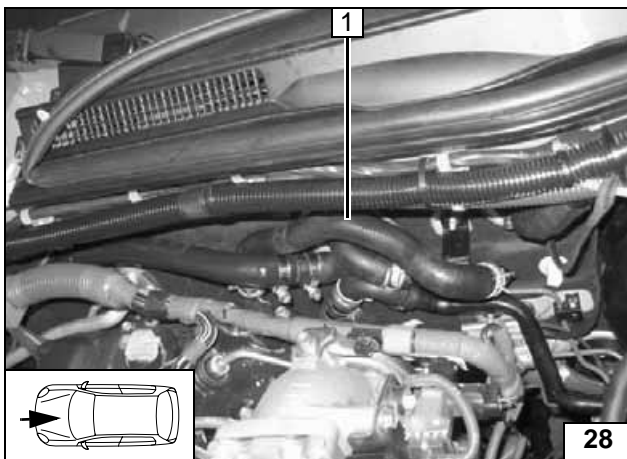

Mount coolant hose between heat exchanger outlet and engine inlet **1** turned by 180°.



**Conne-
tion on
heat ex-
changer in-
let**

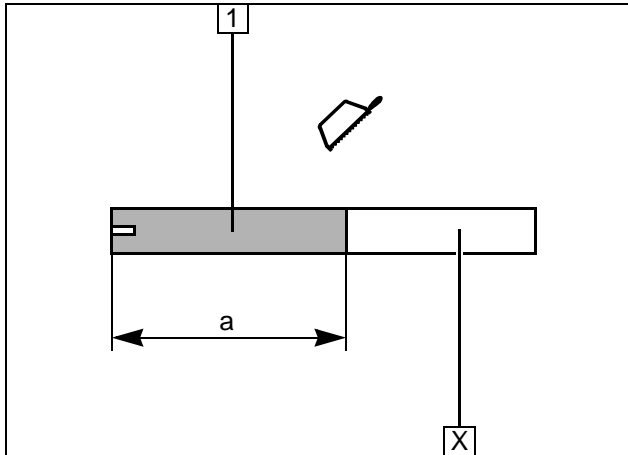
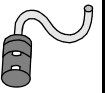

Combustion air

- 1 Combustion air pipe
a = 220 mm

Discard section X

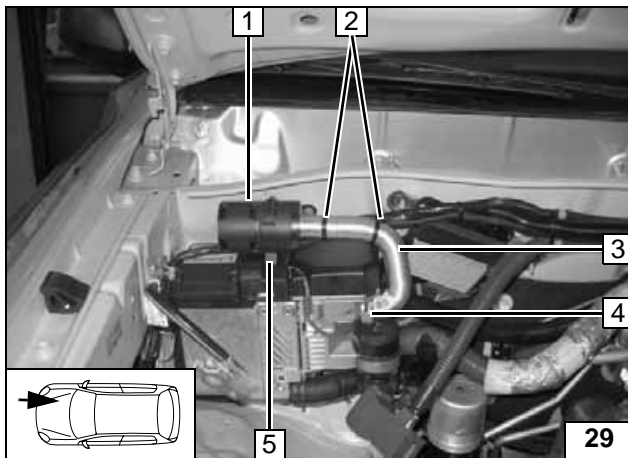

Punch through stamping for hole on lid of heater unit.

- 1 Combustion-air intake muffler
- 2 Fasten wiring harnesses with cable ties
- 3 Combustion-air intake pipe
- 4 27 mm dia. hose clamp
- 5 Retaining clip, in prestamped hole

Cutting combustion air pipe to length



Installing intake pipe



Fuel Connection

CAUTION!

Open the vehicle's fuel tank cap, ventilate the tank and then re-close the tank lock.

Catch any fuel running off with an appropriate container.

Install fuel line and metering-pump wiring harness so that they are protected against stone impact. Unless specified otherwise, always fasten using cable ties.

Mount the fuel line and wiring harness with rub protection on sharp edges.

WARNING!

The fuel line and wiring harness are routed to the metering pump in as shown in the wiring harness routing diagram.

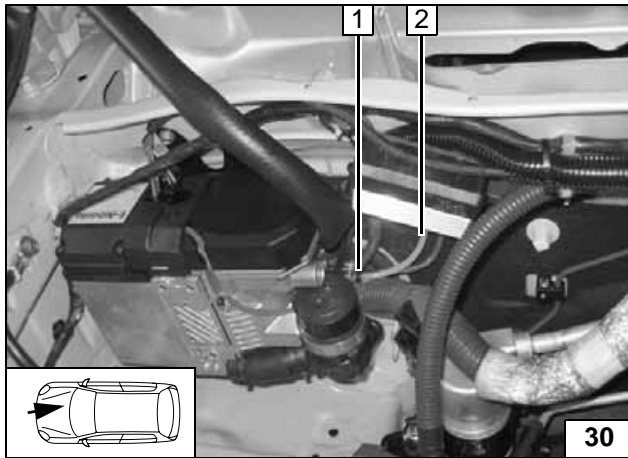

- 2 Mecanyl fuel line
- 1 Premounted hose section, 10 mm dia. hose clamp

Conne-
tion on
heater unit

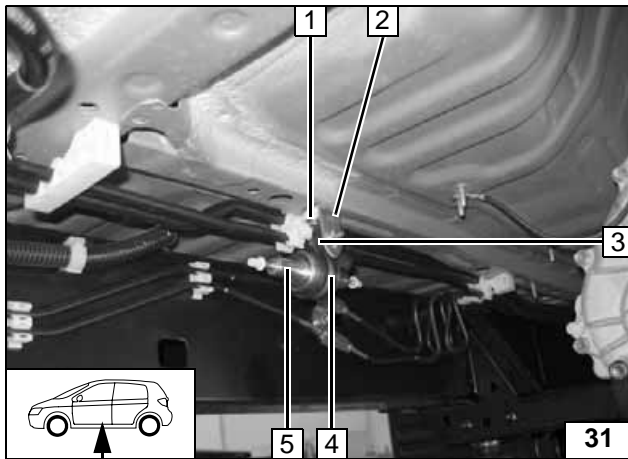

Ensure proper installation position of metering pump, see "Installation Instructions".
Installation location on right next to vehicle fuel tank.
Fuel line from heater unit on pressure side of metering pump [side with connector].

- 1 Original vehicle bolt
- 2 Angle bracket
- 3 Silent block, flanged nut [2x]
- 4 Rubber-coated pipe clamp
- 5 Metering pump

Installation
location of
metering
pump

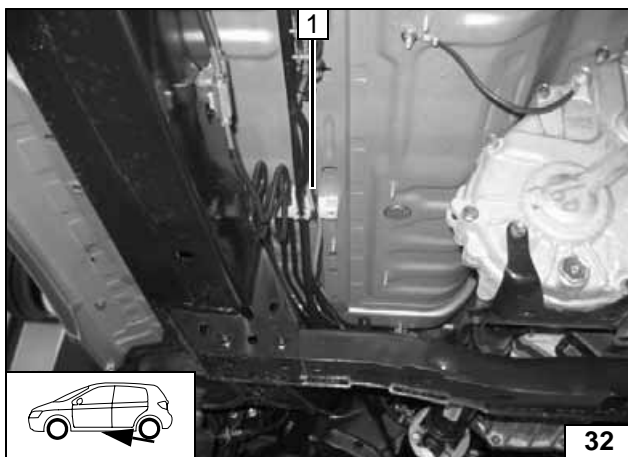

- 1 Mecanyl fuel pipe, metering pump cable harness

Installing
lines

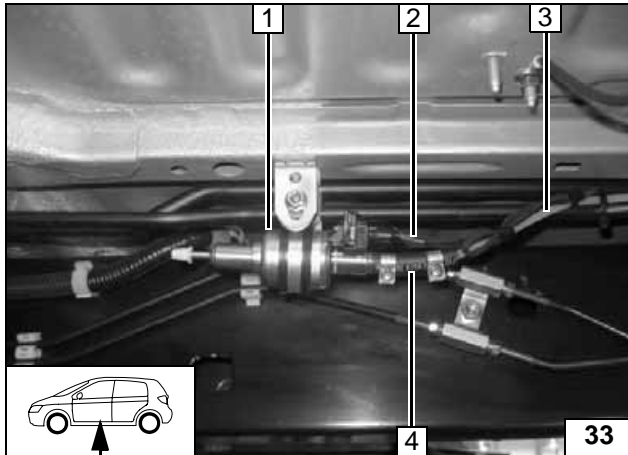

- 1 Metering pump
- 2 Wiring harness for metering pump, wire sealing [2x], tab connector, connector housing
- 3 Fuel line
- 4 Hose section, 10 mm dia. hose clamps [2x]

**Conne-
ction to me-
tering
pump**

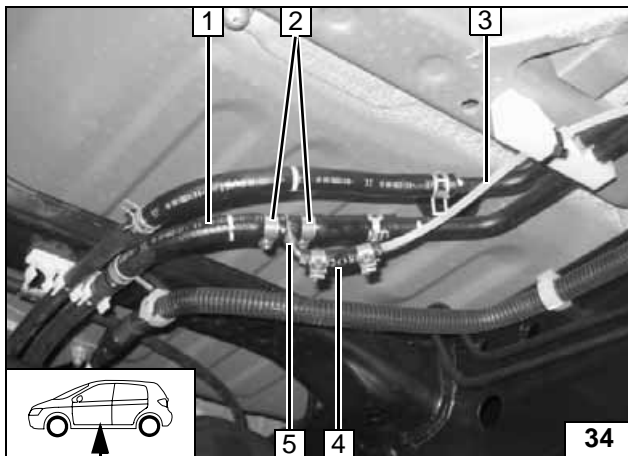

Disconnect fuel supply line.

- 1 Fuel supply line
- 2 14 mm dia. hose clamps [2x]
- 3 Fuel line
- 4 Hose section, 10 mm dia. hose clamps [2x]
- 5 10x5x10 fuel standpipe



**Mounting
fuel
standpipe**

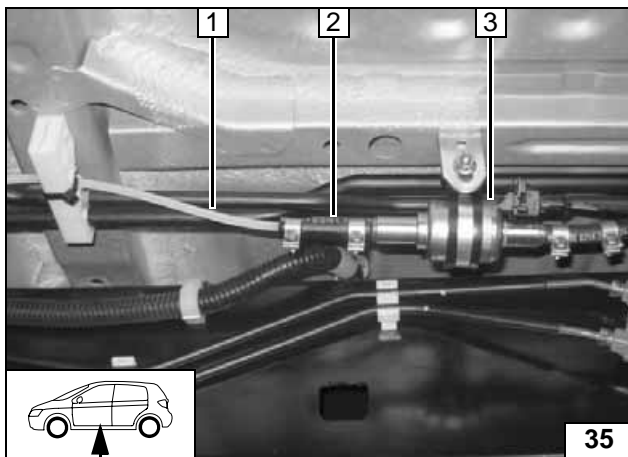

Fuel line from fuel standpipe on intake side of metering pump [side without connector]. Check the position of the components; adjust if necessary. Check that they have free clearance.

- 1 Fuel line
- 2 Hose section, 10 mm dia. hose clamps [2x].
- 3 Metering pump



**Conne-
ction to me-
tering
pump**

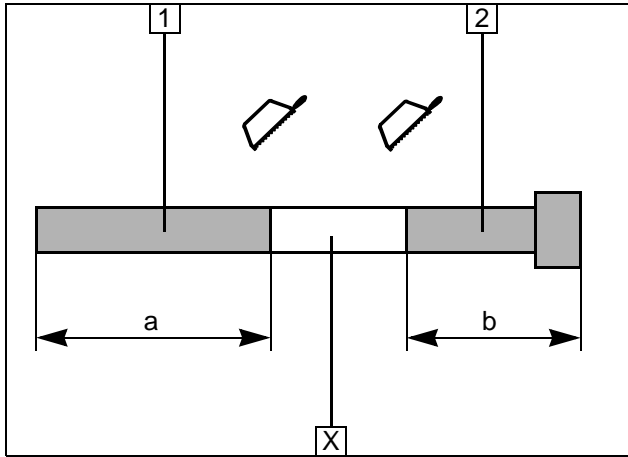
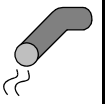

Exhaust system

- 1 Exhaust pipe
a = 670 mm
- 2 Exhaust end section
b = 140 mm

Discard section X

Preparing exhaust pipe

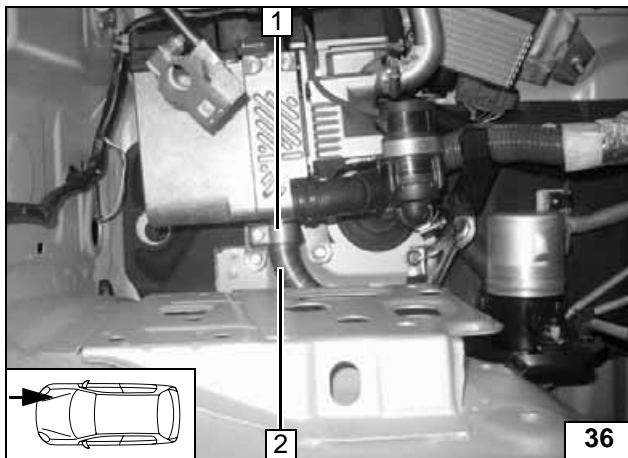

- 1 Hose clamp
- 2 Exhaust pipe

Connection on heater unit

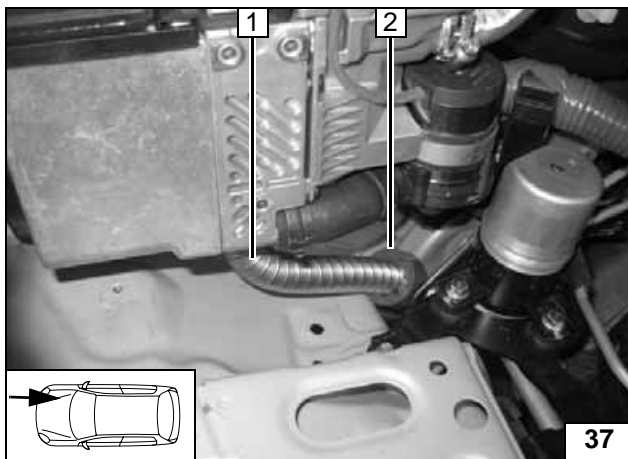

Ensure sufficient distance to neighboring components.

- 1 Exhaust pipe
- 2 Red (rt) rubber isolator

Positioning rubber isolator

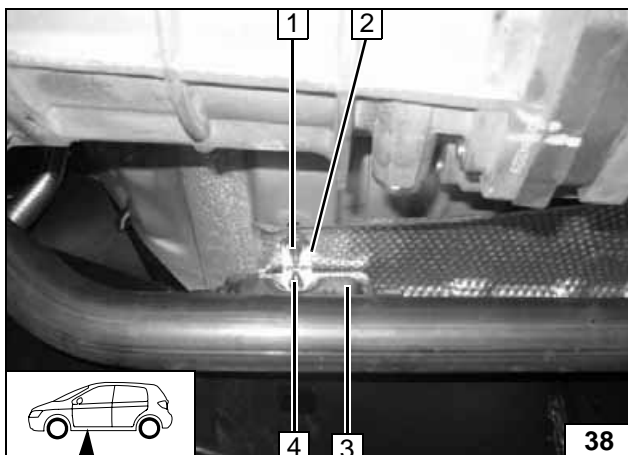

Version A

Ensure sufficient spacing to neighboring components.

- 1 Original vehicle bolt
- 2 Angle bracket
- 3 Exhaust muffler
- 4 M6x20 bolt, flanged nut

Installing muffler

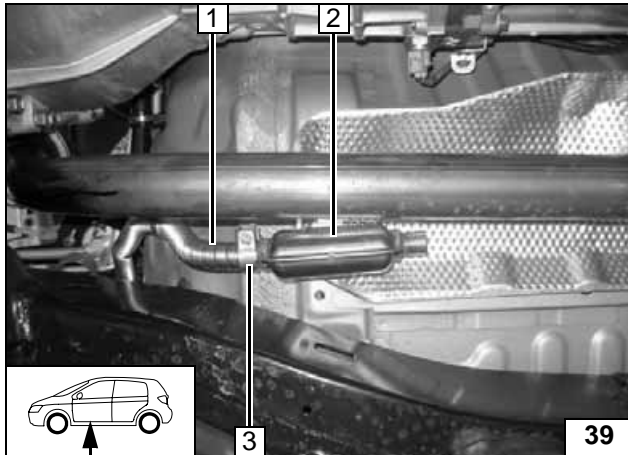
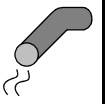

- 1 Exhaust pipe
- 2 Exhaust muffler
- 3 Hose clamp

Installing exhaust pipe

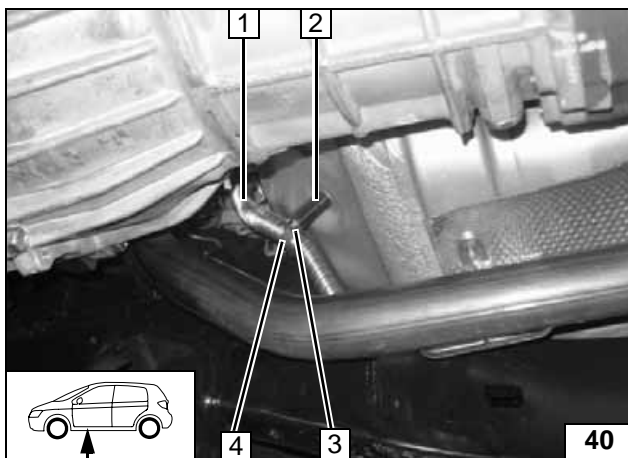

- 1 Exhaust pipe
- 2 Original vehicle bolt, 40 mm spacer nut
- 3 M6x20 bolt, spring lockwasher
- 4 P-clamp

Fastening exhaust pipe

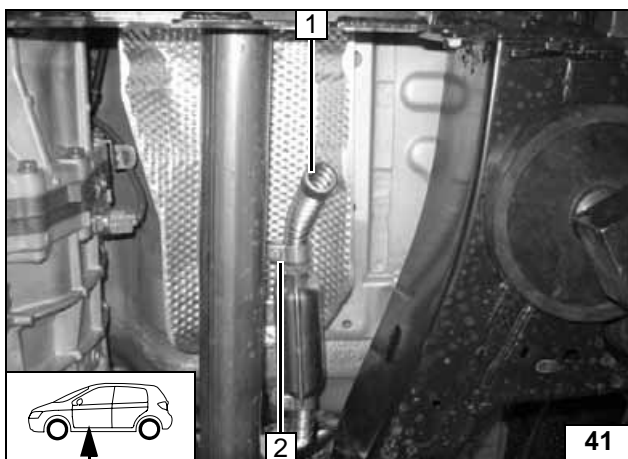

- 1 Exhaust end section
- 2 Hose clamp

Installing exhaust end section

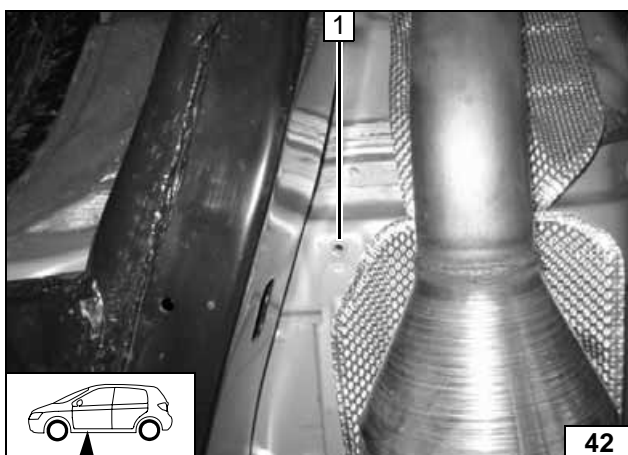

Version B

Mount rivet nut 1 in existing hole.



Installing muffler

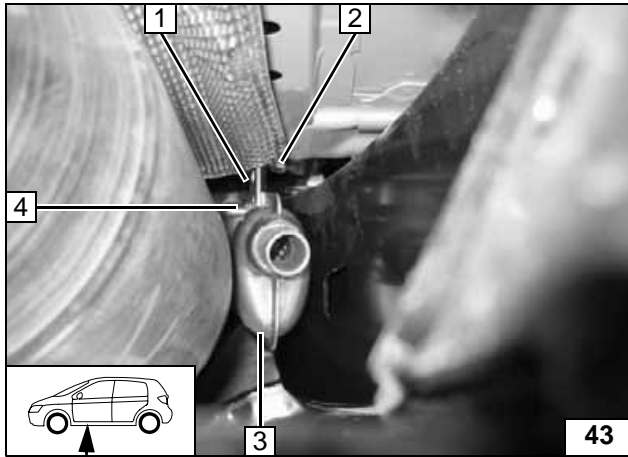
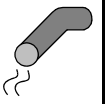

- 1 Angle bracket
- 2 M6x20 bolt, spring lockwasher
- 3 Exhaust muffler
- 4 M6x20 bolt, M6 flanged nut

Installing muffler

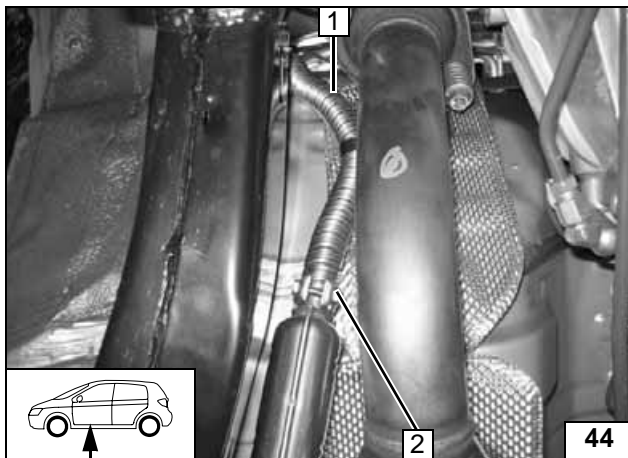

- 1 Exhaust pipe
- 2 Hose clamp

Installing exhaust pipe

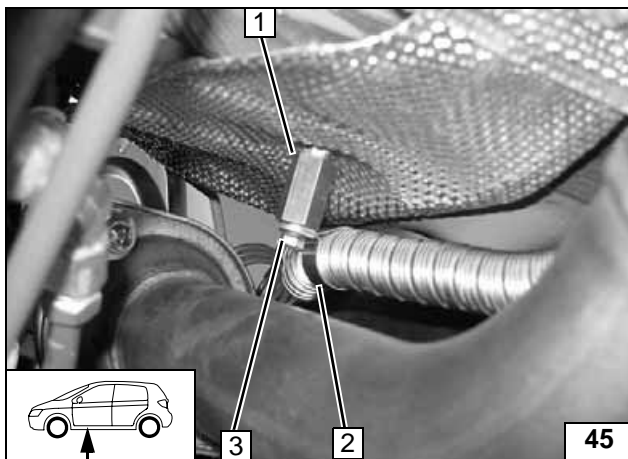

- 1 Original vehicle bolt, 40 mm spacer nut
- 2 P-clamp
- 3 M6x20 bolt, spring lockwasher

Fastening exhaust pipe

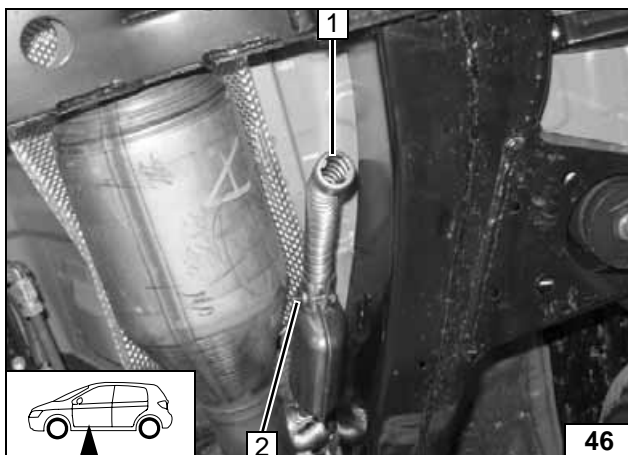

- 1 Exhaust end section
- 2 Hose clamp

Installing exhaust end section



Final Work

WARNING!

Reassemble the disassembled components in reverse order.

Check all hoses, hose, spring and Caillau clamps, as well as all electrical connections for firm seating. Secure all loose cables using cable ties.

Spray the heater unit components with anti-corrosion wax (Tectyl 100K, Order No. 111329).

- Connect the battery
- Start the engine, bleed the coolant circuit according to the instructions of the vehicle manufacturer and add coolant
- Set the digital timer.
- Adjust the vehicle heater with automatic air-conditioning or without automatic air-conditioning according to "Operating Instructions for End Customer".
- Check the proper operation of the additional heater, see the operating instructions/installation instructions.
- Attach the "Switch off additional heater before refueling" sticker to the left-hand B-pillar.



Webasto

Feel the drive

Webasto AG
Postfach 80 - 82132 Stockdorf, Germany - Hotline +49-
(0)1805-932278
Hotfax +49-(0)395-5592-353 - <http://www.webasto.de>

Operating Instructions for End Customer

Please remove page and add to the vehicle operating instructions.



Before parking the vehicle, make the following settings:

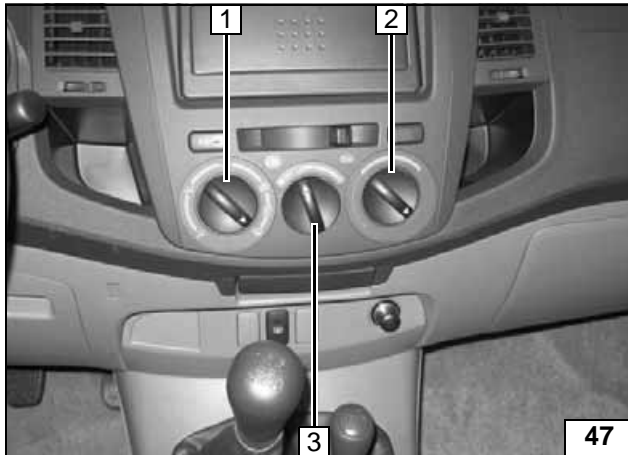

- 1 Air outlet to windshield
- 2 Set temperature to "max."
- 3 Set fan to level "1"

For all vehicles

When driving short distances, it is recommended that the rear window defroster not be used!

Rule of thumb for operating additional heater: driving time = heating time!

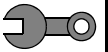

Template 01:
Bend bracket

$a = 20 \text{ mm}$

$b = \text{approx. } 20^\circ$

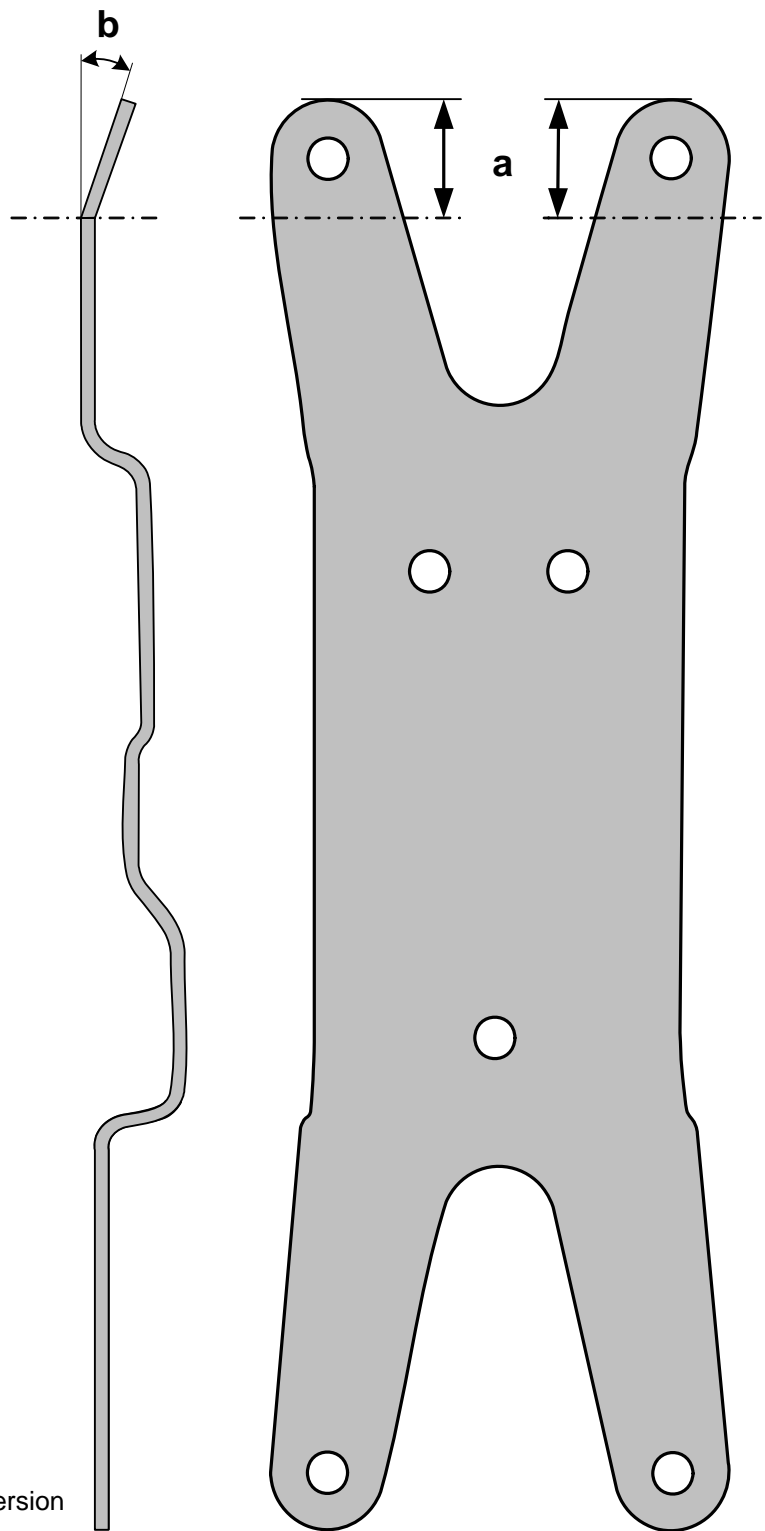

100 mm



Scale 1:1

Compare the size of the printed version with dimension lines.
Permitted tolerance a maximum of 2%.

Correct major differences in the printer settings or request an original printout.

100 mm

0

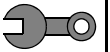

Template 02:
Hole pattern for bracket

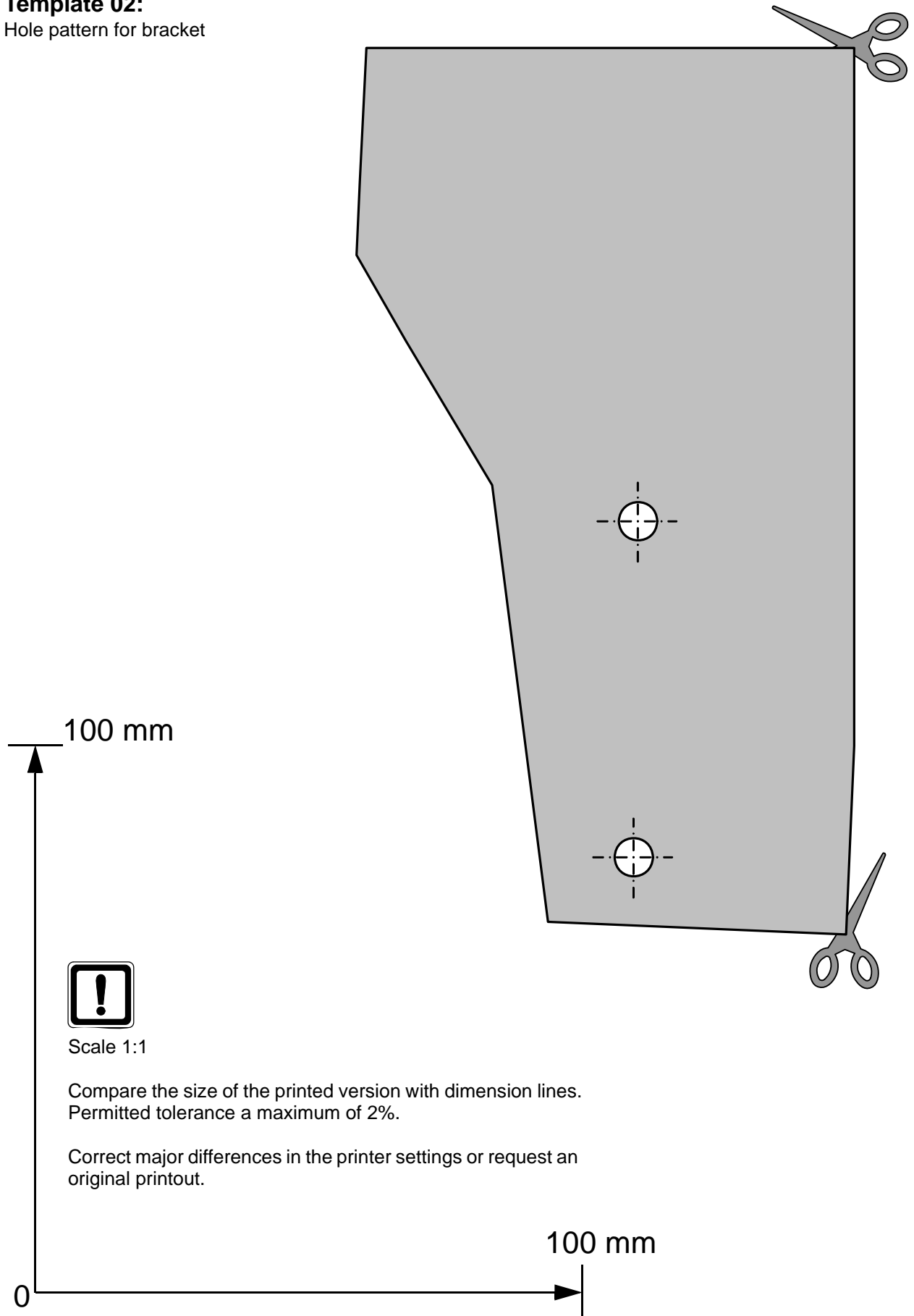

Scale 1:1

Compare the size of the printed version with dimension lines.
Permitted tolerance a maximum of 2%.

Correct major differences in the printer settings or request an original printout.