

Water Heater Unit

Thermo Top E Auxiliary Heating

00 0003

Thermo Top C Auxiliary Heating

00 0002

Thermo Top P Auxiliary Heating

00 0104

Mitsubishi L200

Diesel

From model year 2006

For left-hand drive vehicles only



WARNING!

Hazard warning:

Incorrect installation or repair of Webasto heating systems may cause a fire or result in the emission of carbon monoxide, which can be fatal. Serious or fatal injuries can be caused as a result.

Specialist company training, technical documentation, specialized tools and equipment are required to install and repair Webasto heating and cooling systems.

NEVER attempt to install or repair Webasto heating or cooling systems if you have not successfully completed the company training and thereby acquired the required technical skills or if you do not have access to the required technical documentation, tools and equipment needed to carry out correct installation and repairs.

ALWAYS follow all Webasto installation and repair instructions and observe all warning instructions.

Webasto does not accept any liability for defects and damage that are attributable to an installation by untrained staff.

Table of Contents

Validity	2	Automatic air conditioning blower control	10
Heater Unit / Installation Kit	3	Remote Start Option	12
Foreword	3	Preparing the Installation Location	13
General Instructions	3	Preparing the Heater Unit	14
Special Tools	3	Installing the Heater Unit	15
Explanatory Notes on the Document	4	Water Connection	16
Preliminary Work	5	Combustion Air	19
Heater Unit Installation Location	5	Fuel Connection	20
Preparing the Electrics	6	Exhaust System	22
Electrical Connection	7	Final Work	23
Manual air conditioning blower control	8	Operating instructions for the end customer	23

Validity

Manufacturer	Model	Type	EG-BE No. / ABE
Mitsubishi	L200	KA0T	L716*00

Engine type	Engine	Power in kW	Engine capacity in cm ³
4D56	Diesel	100	2477

Vehicle and engine types, equipment variants as well as national specifications, which are not listed in these installation instructions, have not been tested. Installation according to these installation instructions may, however, be possible.

The installation location of a time switch and summer / winter switch should be confirmed with the end customer before installation.

Heater Unit / Installation Kit

Amount	Description	Order No.:
1	Commercial supply of required control	See price list
1	Installation kit for Mitsubishi L200 Diesel	1311015A

Recommended heater unit for the relevant vehicle class:

Vehicle	Heater unit
Compact car	Thermo Top E
Mid class, station wagon	Thermo Top C
Luxury, van, off-roader	Thermo Top P

Select the heater unit based on the size of the vehicle passenger compartment and the customer's comfort requirements.



Foreword

These installation instructions apply to vehicles Mitsubishi L200 with Dieseline engine – re. validity, see page 2 – from model year and later, assuming technical modifications to the vehicle do not affect installation, any liability claims excluded. Depending on the vehicle version and equipment, modifications may be necessary during installation with respect to these installation instructions.

However, the stipulations in the "installation instructions" and "operating and maintenance instructions" for the *Thermo Top C/P/E* are to be observed in any event.

The corresponding rules of technology and any information from the vehicle manufacturer should be observed during the installation work.

General Instructions

Installation should be carried out according to the general, standard rules of technology. Unless specified otherwise, fasten hoses, lines and cable harnesses to original vehicle lines and cable harnesses using cable clips.

Sharp edges should be fitted with edge protectors (split open plastic hose).

Spray unfinished body areas, such as bore holes for example, with anti-corrosion wax (Tectyl 100K, Order No. 111329).

Special Tools

- Torque spanner for 2.0 - 10 Nm
- Vise-grip wrench
- Riveting nut tool

Explanatory Notes on the Document

To provide you with a quick overview of the individual working steps, you will find an identification mark on the outside top right corner of the page in question.

Mechanics

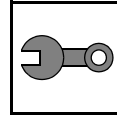

Electrics

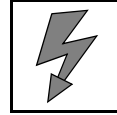

Water connection

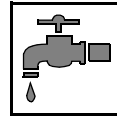

Fuel connection

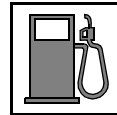

Exhaust system

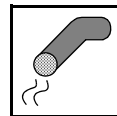

Combustion air

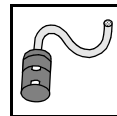

Special features are highlighted using the following symbols:



Specific risk of injury or fatal accidents



Specific risk of damage to components



Specific risk of fire or explosion



Reference to general installation instructions of Webasto components or to the manufacturer's vehicle-specific documents



Reference to a special technical feature

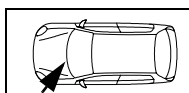
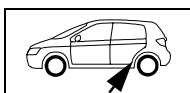

The arrow in the vehicle icon indicates the position on the vehicle and the viewing angle

Preliminary Work

WARNING!

- Disconnect the battery.
- Let off pressure in the cooling system.
- Copy the factory number from the original type label to the duplicate type label.
- Remove years that do not apply from the duplicate label.
- Attach the duplicate label (type label) in the appropriate place.
- Completely remove the battery
- Open the tank cap, ventilate the tank.
- Close the tank cap again.
- Remove air conditioning control (only for automatic air conditioning systems)
- Remove the footwell panel on the driver and passenger side
- Please remove page 23 "Operating instructions for the end customer" and add this to the operating instructions.

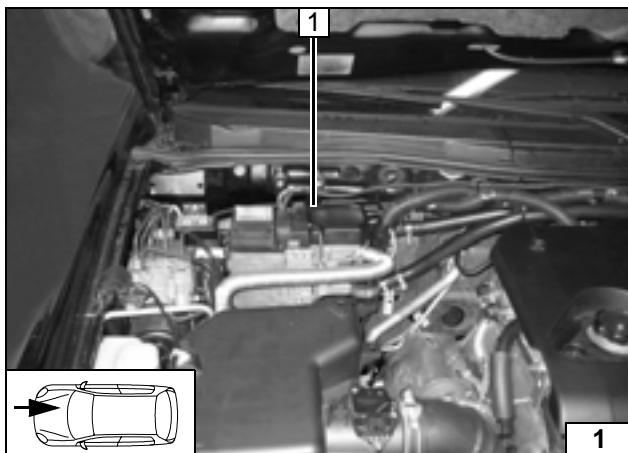

Heater Unit Installation Location

- 1 Heater unit

Installation
location

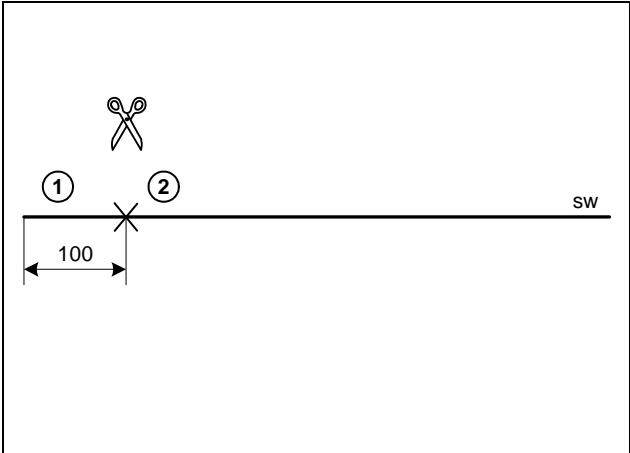

Preparing the Electrics



Only for automatic air conditioning

Wire sections 1, 2 will be needed later for connecting the 4th fuse.

Cutting wires into sections

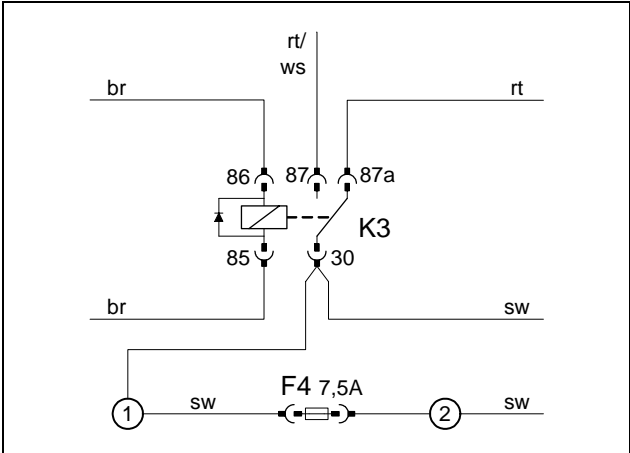

Connect with enclosed blade receptacles according to the circuit diagram. Insert wire section 2 in insulating hoses [2x].

Pre-assembling the 4th fuse



Electrical Connection

Cable harness feed-through

1 Protective rubber sleeve

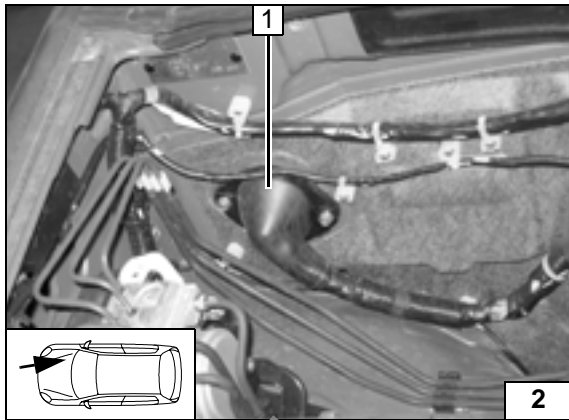

Summer / winter switch option

1 Summer / winter switch, bore hole Ø 12mm,

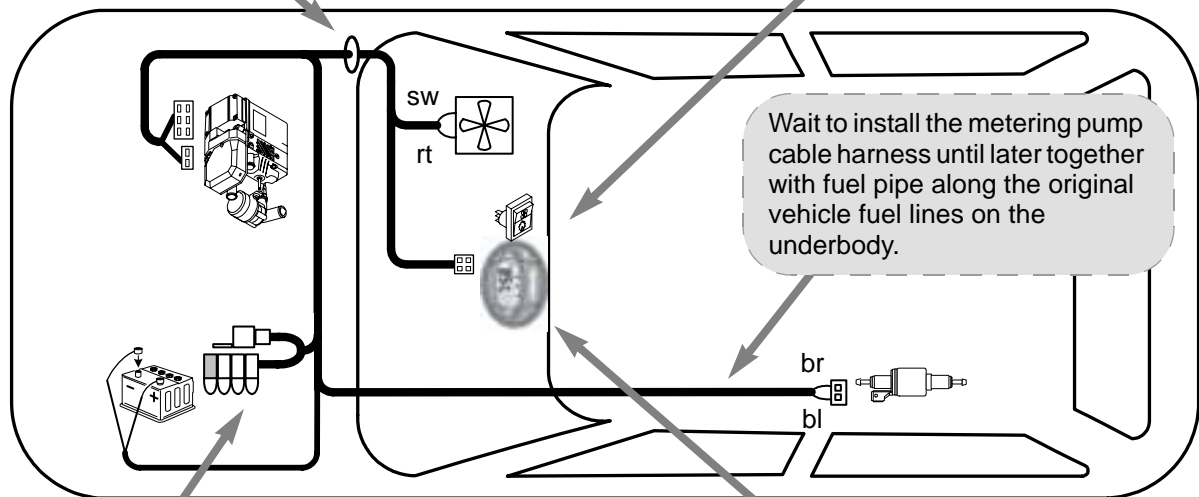
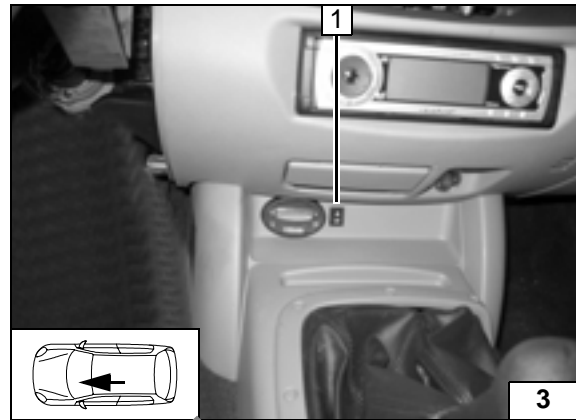

Cable harness installation diagram

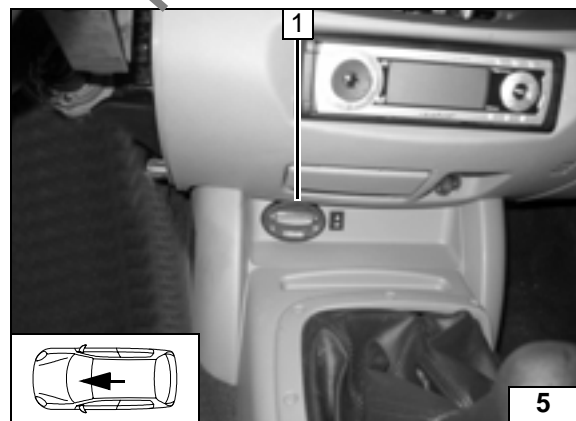
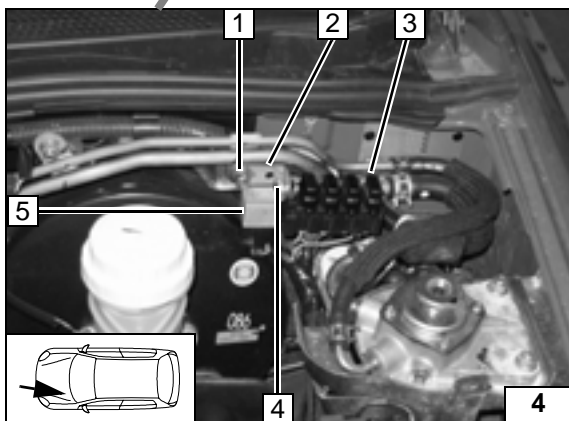

Fuse holder, K3 relay

- 1 Original vehicle stay bolts, body washer, bracket 2, original vehicle nut M8
- 3 Fuse holder
- 4 Bolts M5x16, K3 relay 5, angle bracket, fuse holder retaining plate, washers, nuts M5

Time switch

- 1 Time switch

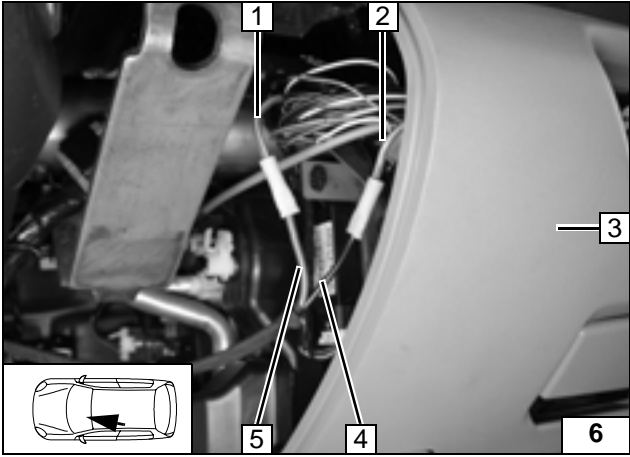

Manual air conditioning blower control

Connection on cable harness between blower relay and blower switch. The cable harness is located behind the steering column panel to the right of the driver. Connect with enclosed butt connectors according to the circuit diagram.

- 1 Blue/yellow (bl/ge) wire from blower relay
- 2 Blue/yellow (bl/ge) wire from blower switch.
- 3 Center console panel
- 4 Black (sw) wire from K3/30
- 5 Red (rt) wire to K3/87a



Connecting the blower motor

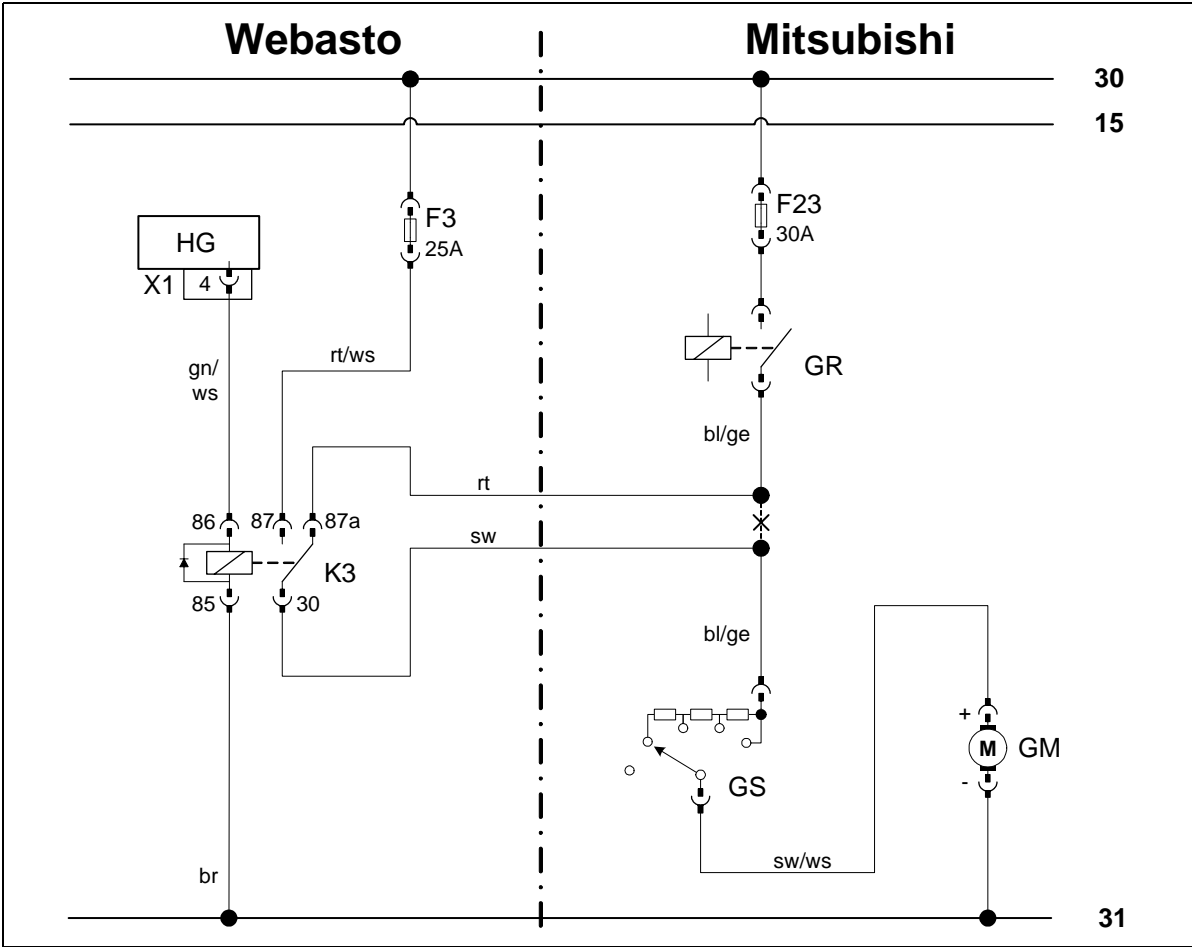

Manual air conditioning circuit diagram

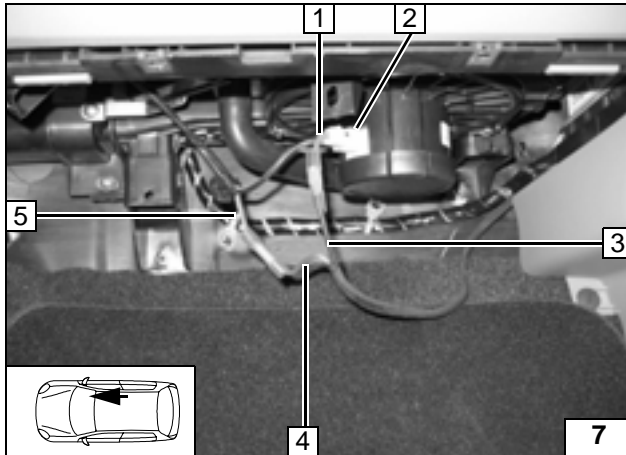

Automatic air conditioning blower control

Connection to 2-pin connector 2 from the blower motor.
Connect with enclosed butt connectors according to the circuit diagram.

- 1 Blue/yellow (bl/ge) wire to blower motor.
- 3 Black (sw) wire from K3/30
- 4 Red (rt) wire to K3/87a
- 5 Blue/yellow (bl/ge) wire from blower relay



Connecting the blower motor

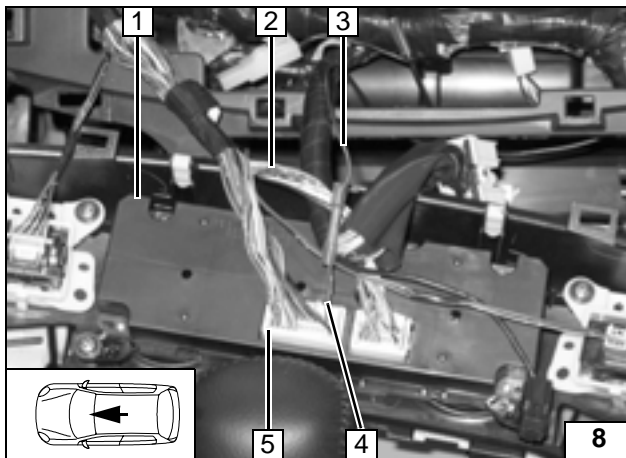

Connection to 22-pin connector C-43 pin 10 5 from the air conditioning control 1.
Connect with enclosed butt connector according to the circuit diagram.

- 2 Insulate the blue/red wire from fuse F16 and tie back the ends.
- 3 Black (sw) wire from K3/30
- 4 Blue/red (bl/rt) wire to air conditioning control.



Air conditioning control connection

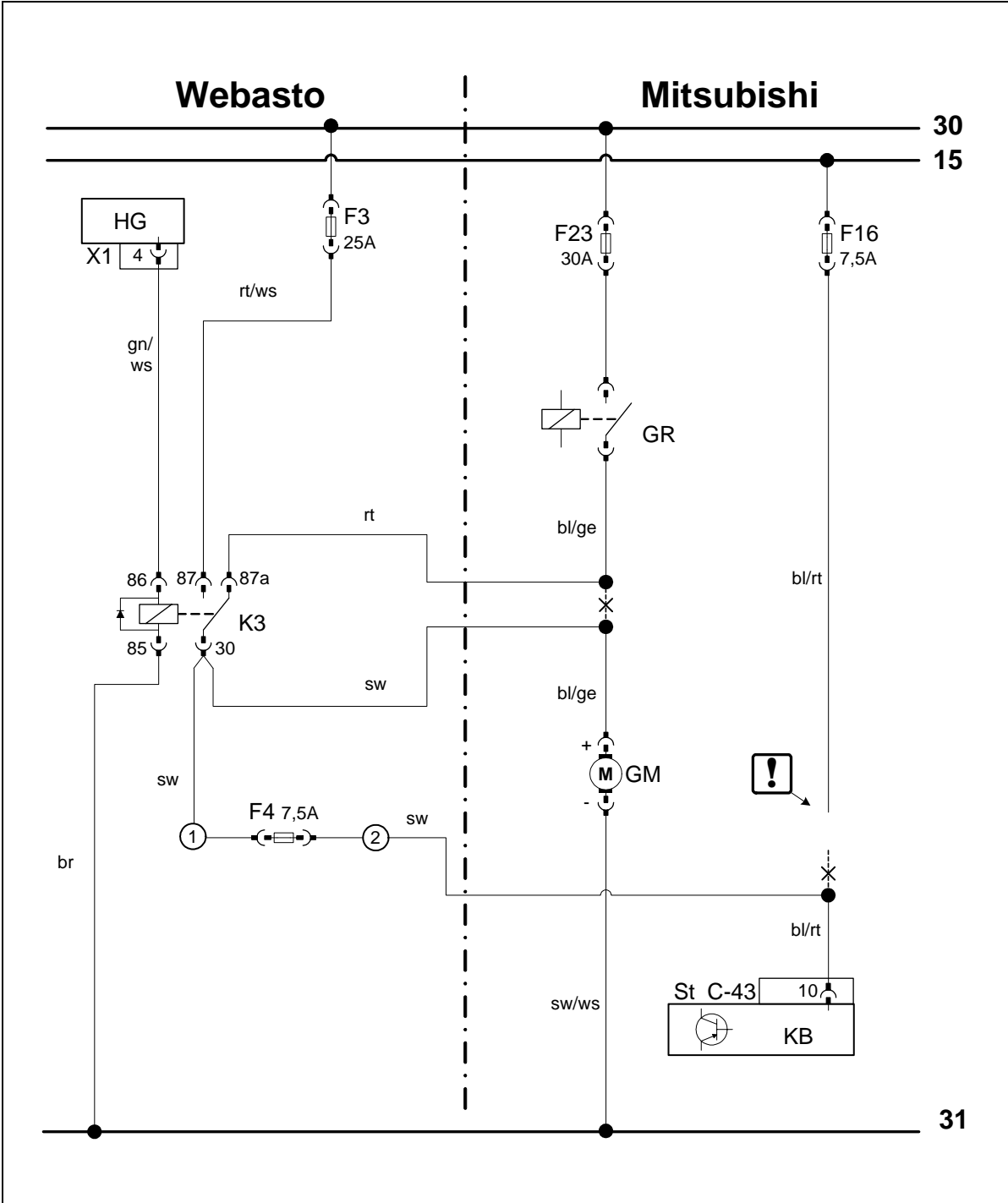

Automatic air conditioning circuit diagram

Webasto components		Components Mitsubishi L200		Colors and symbols	
HG	Heater unit TT-C/E	GM	Blower motor	rt	red
X1	6-pin connector	GR	Blower relay	ws	white
F3	Fuse	KB	Air conditioning control	sw	black
K3	Blower relay	F16	Fuse, air conditioning control	br	brown
F4	Fuse	F23	Fuse GM	gn	green
		St C- 43	22-pin connector pin 10	bl	blue
				ge	yellow
					Insulate and tie back wire ends
				X	Splitting point
					Cable colors may vary.

Legend

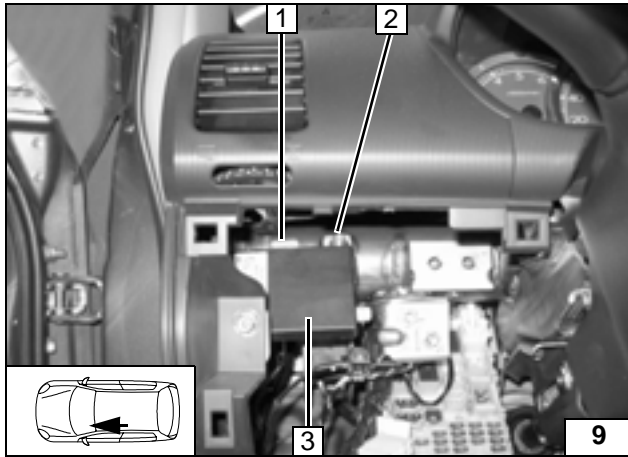
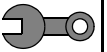

Remote Start Option

- 1 Remote start bracket
- 2 Original vehicle bolt, flanged nut M6 (drill bore hole in the bracket to 7 mm).
- 3 Remote start



Assembling the receiver

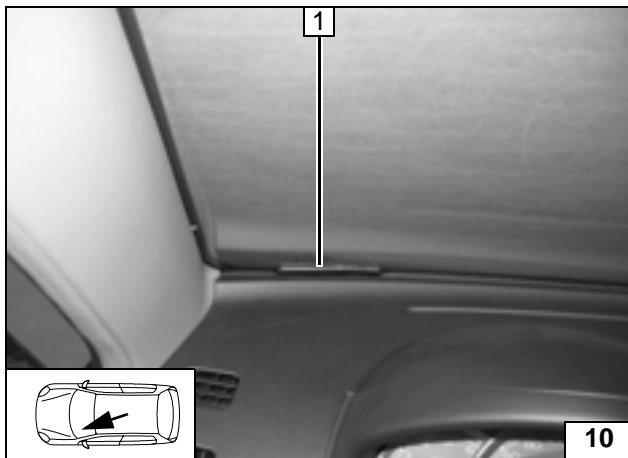

- 1 Antenna

Assembling the antenna

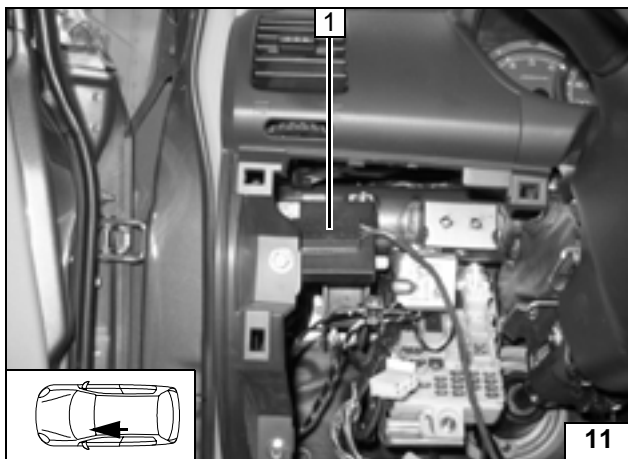

Temperature sensor for HTM100 only

- 1 Attach the temperature sensor to the remote start with double-sided adhesive assembly tape

Assembling the temperature sensor

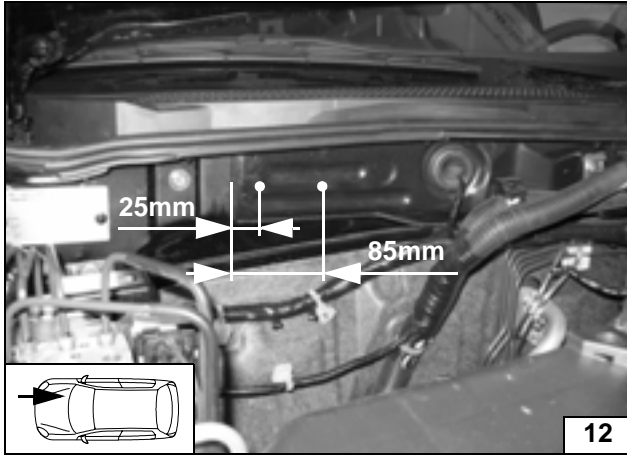
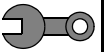

Preparing the Installation Location

Transfer hole image with the corresponding dimensions, drill $\varnothing 9.1$ mm bore hole and insert M6 rivet nuts.



Copy the hole image

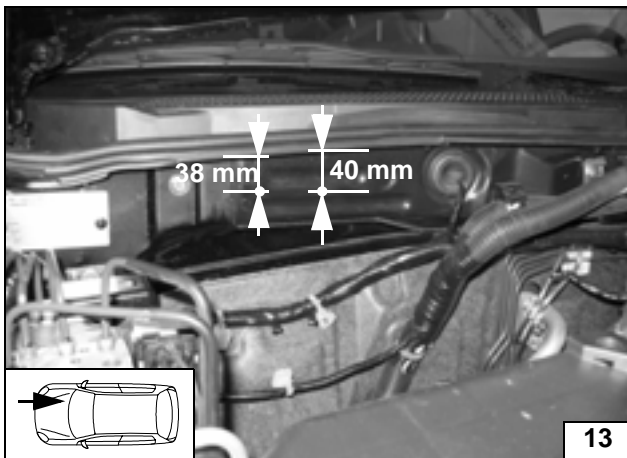

Copying the hole image

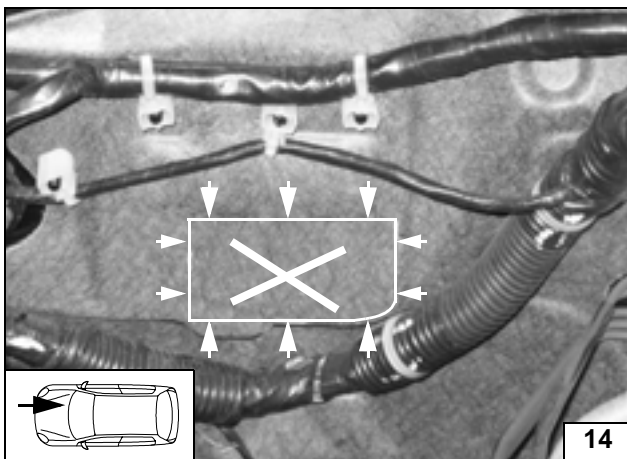

Cut out the insulation on the marking
Dispose of section X

Cutting out the insulation

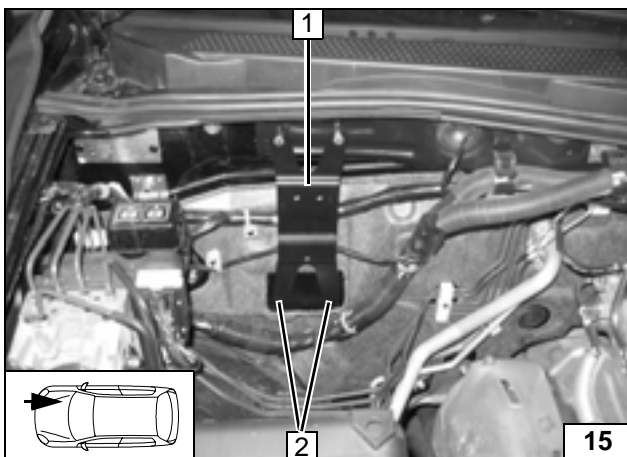

- 1 Loosely fit the bracket
- 2 Transfer hole image, drill $\varnothing 9.1$ mm bore hole; insert rivet nuts [2x]

Copying the hole image

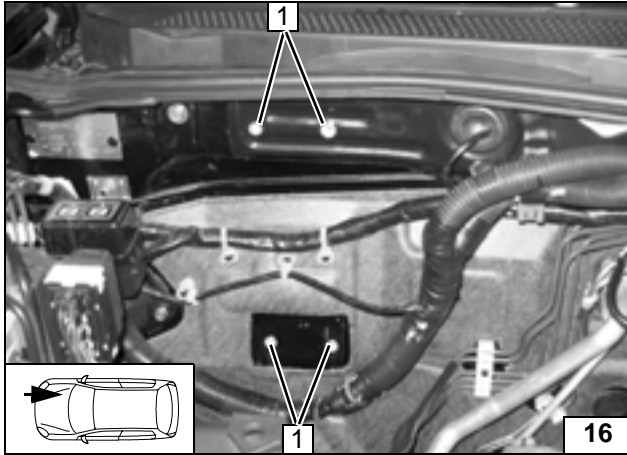
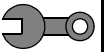

1 Rivet nuts M6 [4x]

Inserting rivet nuts

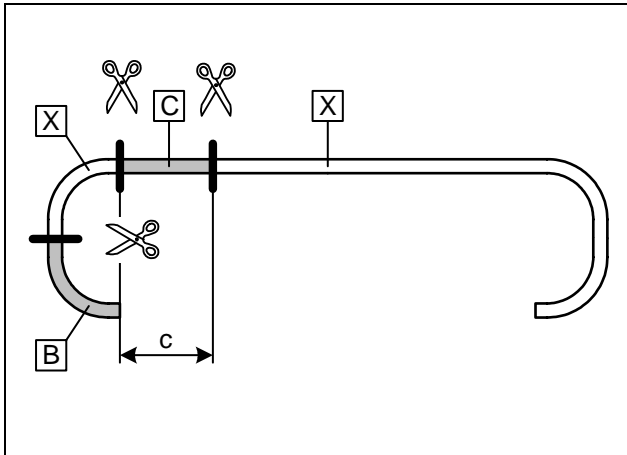

Preparing the Heater Unit

Water hose 1 Ø 20mm

c = 140 mm

Dispose of section X

Cutting water hose 1 into sections

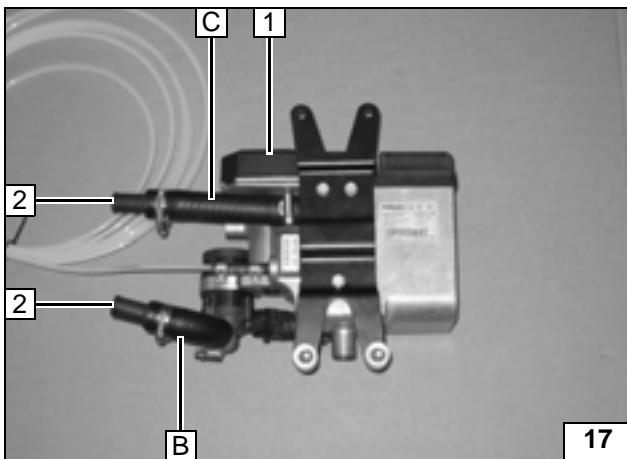

Assemble hose B and hose C as well as the connecting pipe 2.

- 1 Heater unit
- 2 Connecting pipe 18x20 [2x]

Pre-assembling water hose 1 on the heater unit

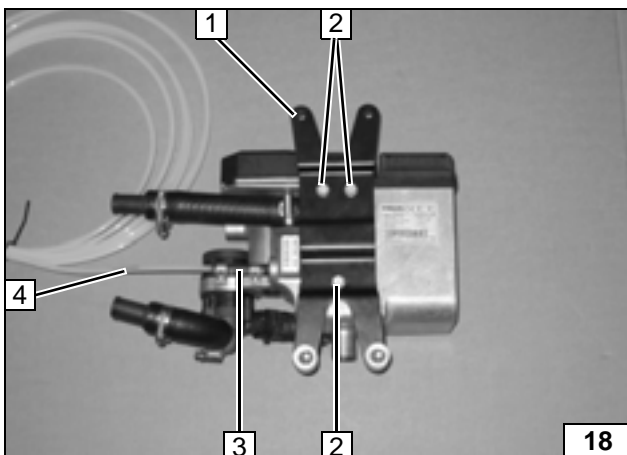

Eject screw bolts tightening torque 10 Nm!

- 1 Bracket
- 2 Eject screw bolt [3x]
- 3 Hose section, Ø 10 mm hose clamps [2x]
- 4 Mecanyl fuel line

Pre-assembling the bracket and fuel on the heater unit

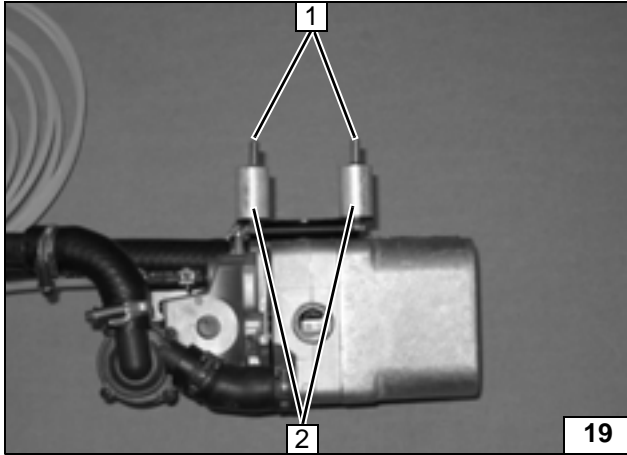

- 1 M6x20 bolt [2x], spring washer [2x]
- 2 30 mm long spacer [2x], bolt protector [2x]

Pre-assembling the bolts on the bracket

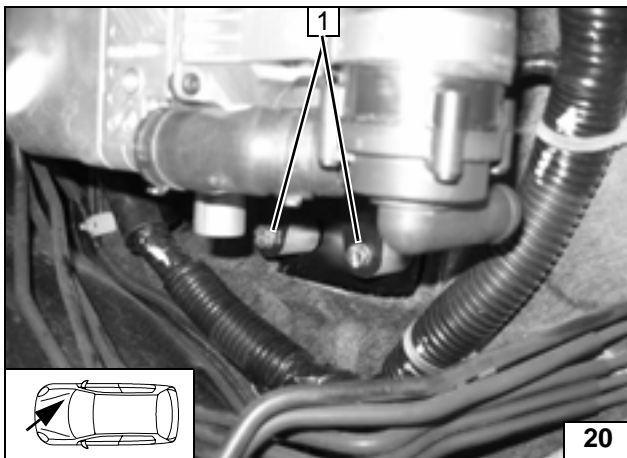

Installing the Heater Unit

First, loosely fit the pre-assembled bolts 1.



Assembling the heater unit

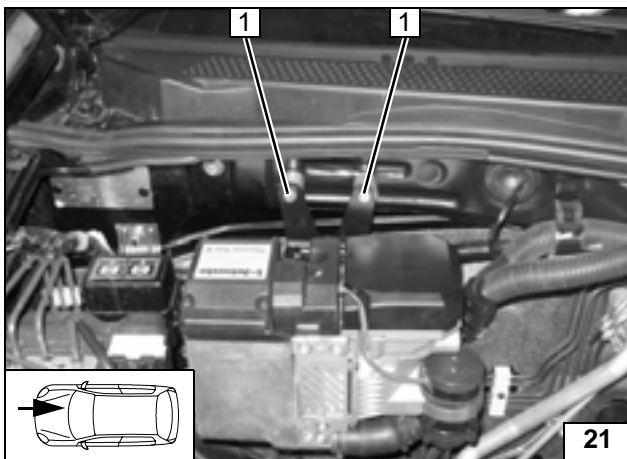

- 1 M6x35 bolt [2x], spring washer [2x], 20 mm spacer [2x]

Assembling the heater unit

When finished, tighten all bolt connections.





Water Connection

WARNING!

Tighten all hose clamps with 2.0 + 0.5 Nm.

Any coolant running off should be collected using an appropriate container!

Install hoses so that they are kink-free. Unless specified otherwise, always fasten using cable clips.

Position hose clamps and spring band clamps so that no other hose can be damaged.

The connection should be "inline" based on the following diagram:

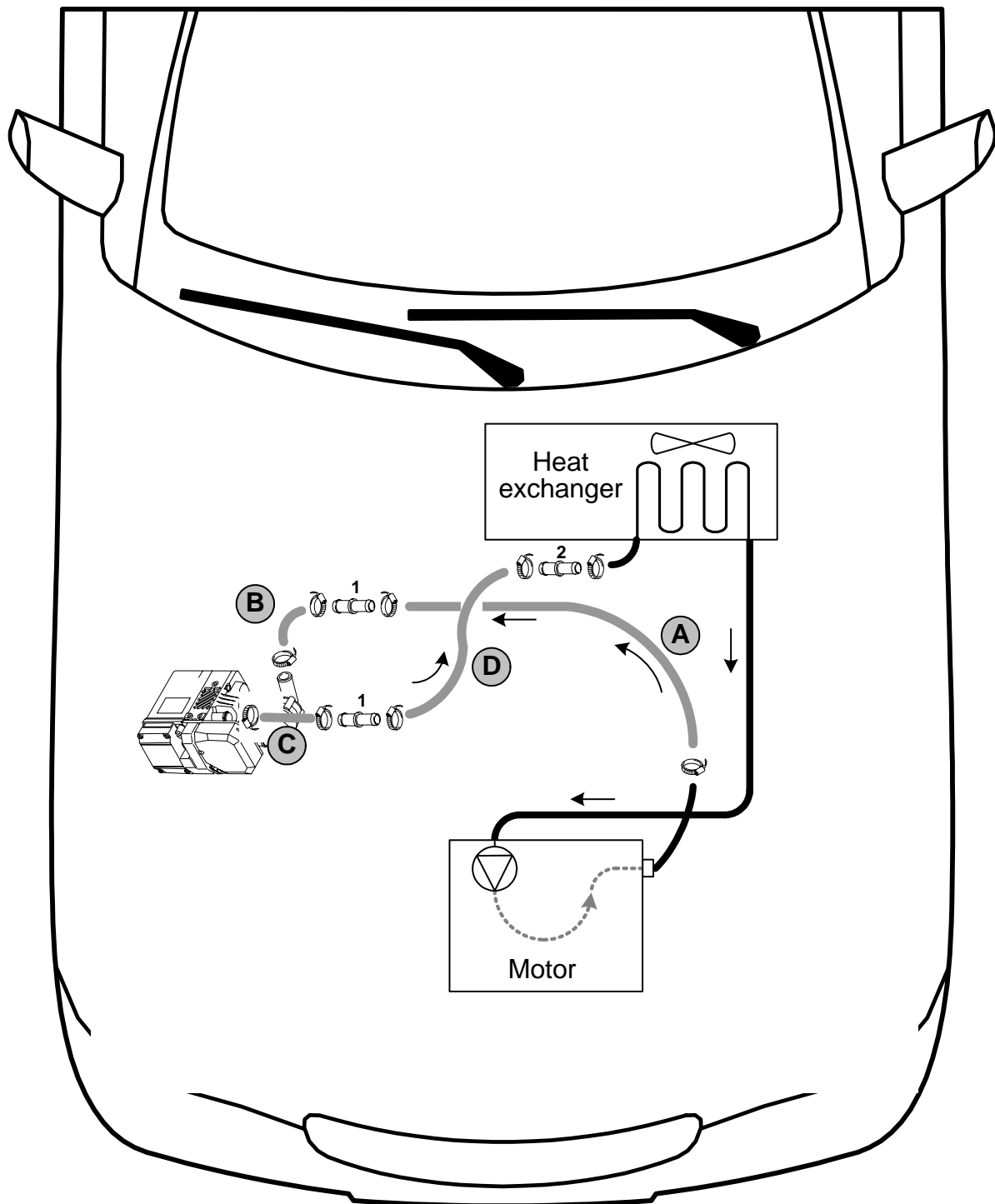

Water installation diagram

All undesigantated clamps are \varnothing 20-27 mm hose clamps.

All connecting pipes 1= \varnothing 18x20 and all connecting pipes 2 = \varnothing 18x18.



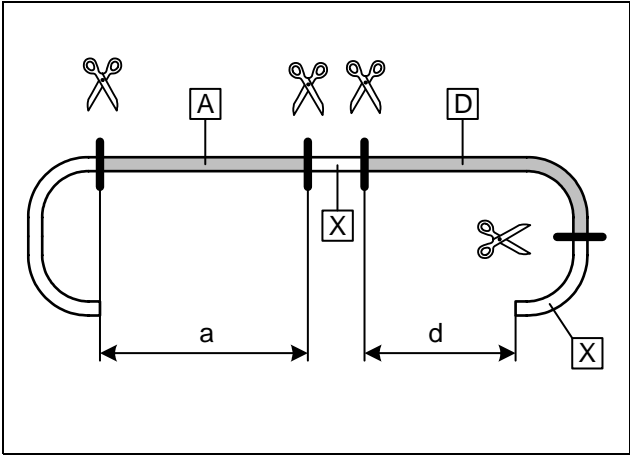

a = 800 mm
b = 440 mm

Dispose of section X

Cutting water hose 2 into sections

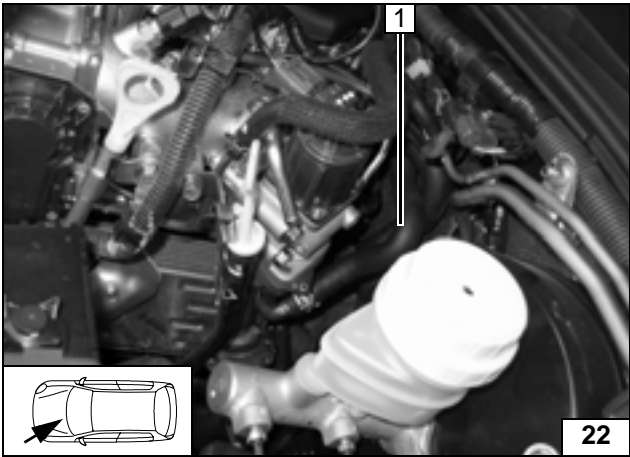

1 Disassemble original vehicle hose from the engine outlet to the heat exchanger inlet. (The clamp from the heat exchanger inlet will be used again.)

Splitting point

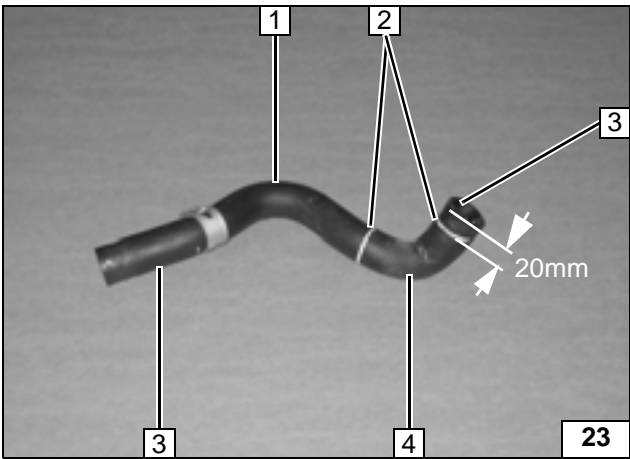

1 Original vehicle hose from the engine outlet to the heat exchanger inlet.
2 Splitting points [2x]
3 Dispose of sections
4 Required heat exchanger inlet moulded hose

Cutting the hose

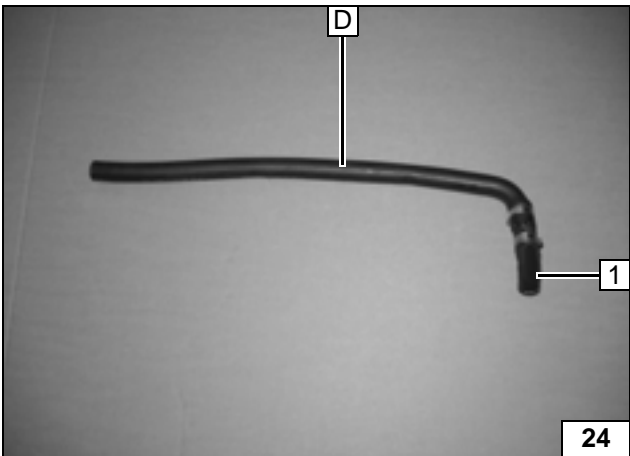

1 Original vehicle hose to the heat exchanger inlet

Pre-assembling the hose

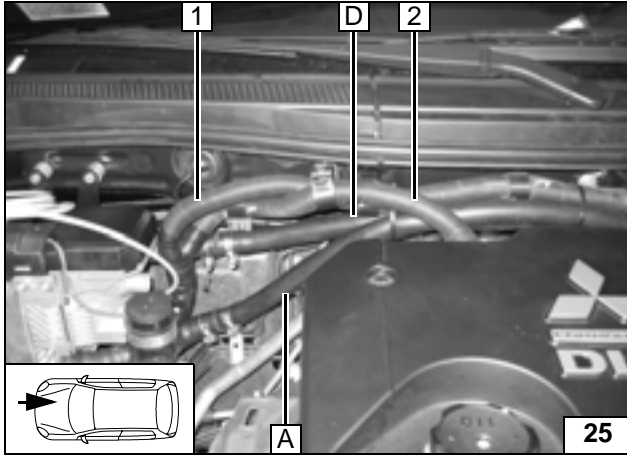
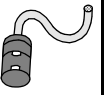

Before installing the water hoses in the engine compartment, install the two cable harnesses **1**, **2** according to the illustration.



Connecting to the heater unit

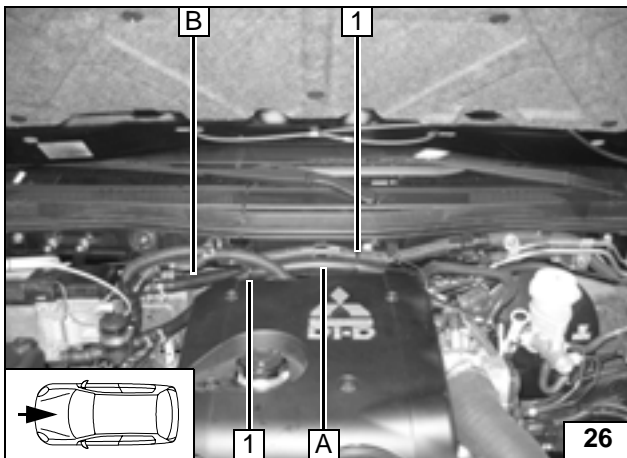

Fasten the water hoses to original vehicle cable harness with cable clips **1**. Ensure sufficient distance to the engine.



Installing in the engine compartment

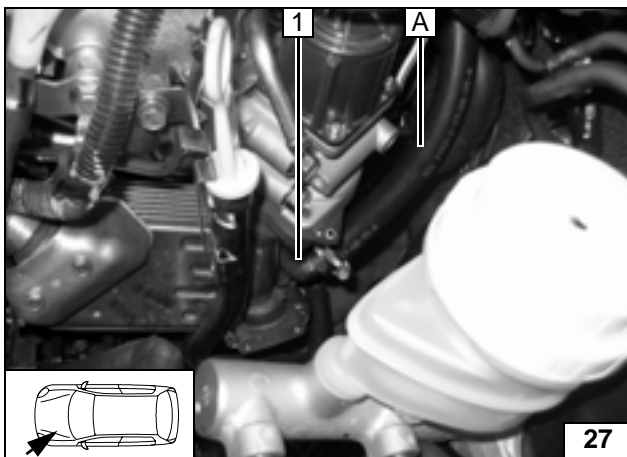

Before connecting, fill the water hoses with coolant.

1 Engine outlet connecting piece



Connecting to the engine outlet

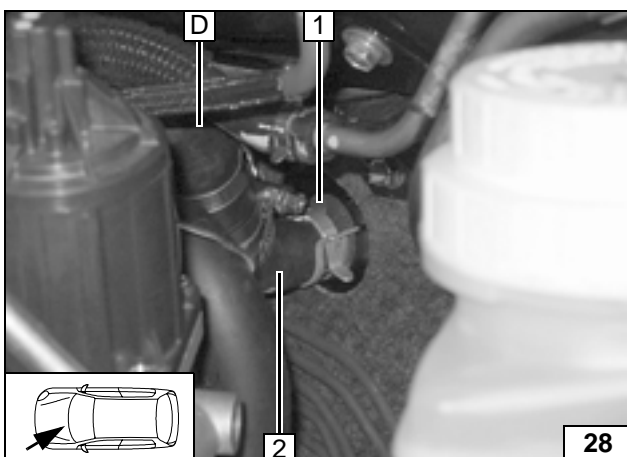

Before connecting, fill the water hoses with coolant.

1 Original vehicle clamp
2 Pre-assembled heat exchanger inlet hose



Connecting to the heat exchanger inlet

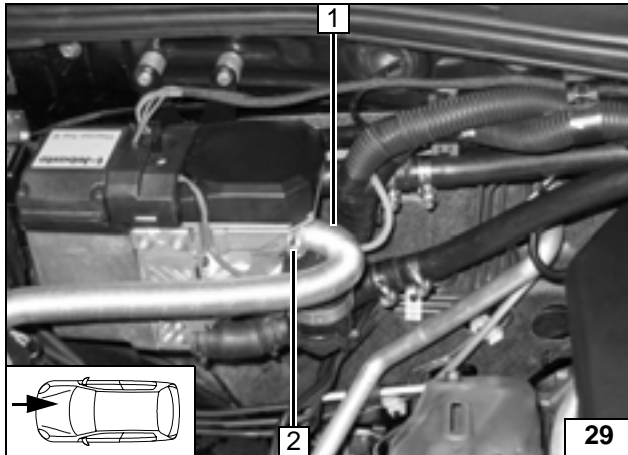

Combustion Air

- 1 Combustion air intake pipe
- 2 Ø 27 mm hose clamp



Assembling the vacuum line

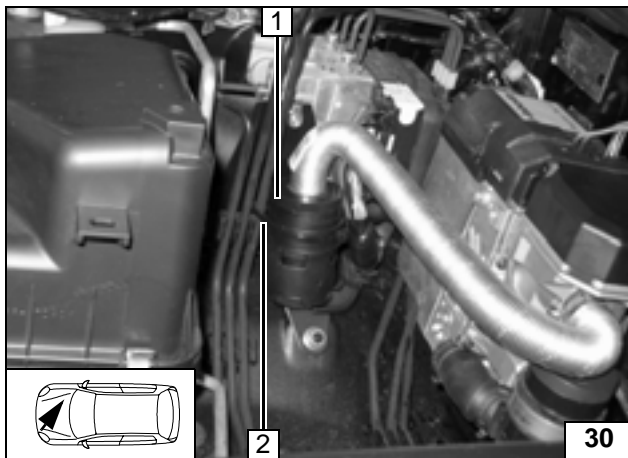

- 1 Combustion air intake silencer
- 2 Cable clip

Assembling the silencer



Fuel Connection

CAUTION!

Open the vehicle's tank-cap lock, ventilate the tank and then re-close the tank lock.

Catch any fuel running off with an appropriate container.

Install fuel line and metering pump cable harness so that they are protected against stone impact. Unless specified otherwise, always fasten using cable clips.

Fit the fuel line and cable harness with edge protectors around sharp edges.

WARNING!

The fuel line and cable harness to the metering pump should be installed based on the cable harness installation diagram.



Installing wires

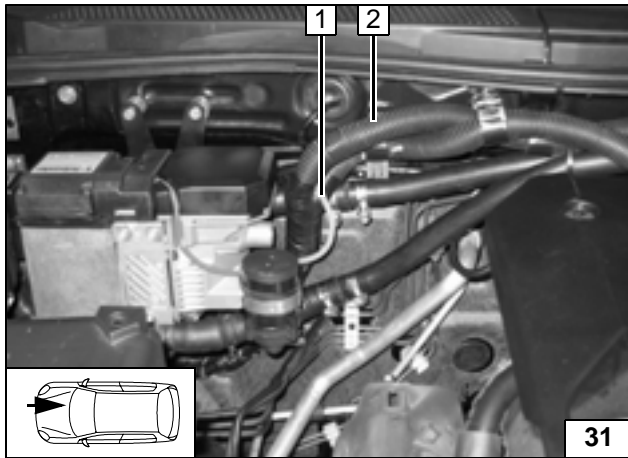

Install the Mecanyl fuel pipe 1 in the tube shaft 2 on the right side of the vehicle.

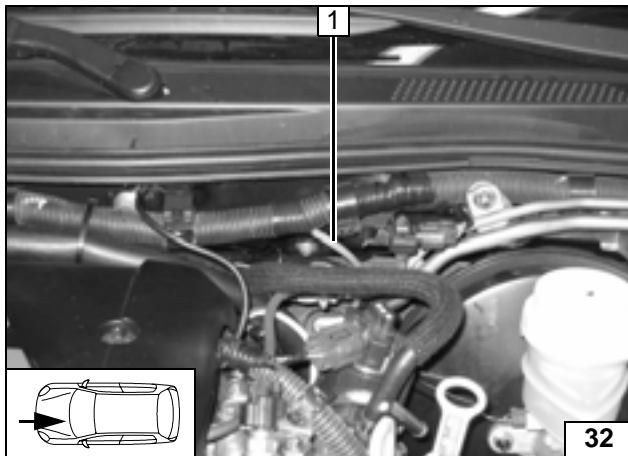

Install the Mecanyl fuel pipe 1 together with the metering pump cable harness to the installation location of the metering pump along the original vehicle fuel lines.



Installing wires

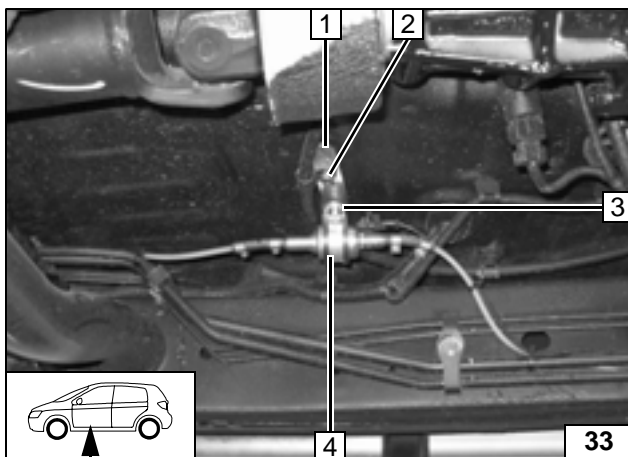

Note the installation position of the metering pump, see the Installation Instructions. Installation location is to the right next to the vehicle tank. Fuel line from the heater unit on the pressure side of the metering pump [side with connector].

- 1 Fastening strap with holes
- 2 Original vehicle bolt M8
- 3 Silentblock, flanged nut M6 to fastening strap with holes
- 4 Rubberized tube clamp; flanged nut M6 to silentblock



Metering pump installation location

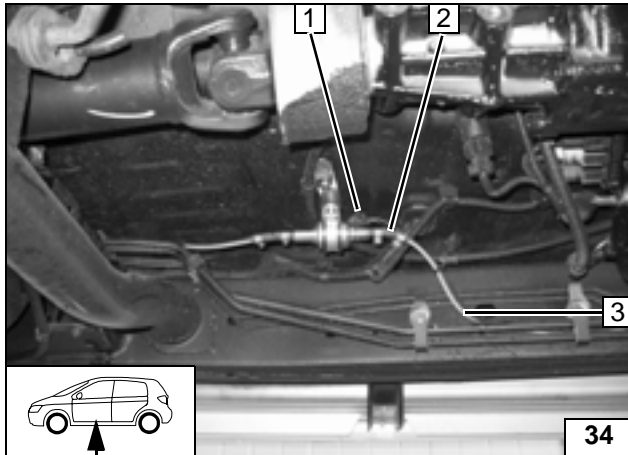
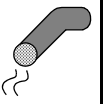

Fuel line from the fuel extractor on the intake side of the metering pump [side without connector].
Check the position of the components; adjust if necessary. Check that these rotate freely.

- 3 Fuel line with metering pump cable harness to original vehicle fuel lines
- 2 Hose section, Ø 10 mm hose clamps [2x]
- 1 Connector housing



Connecting to the metering pump

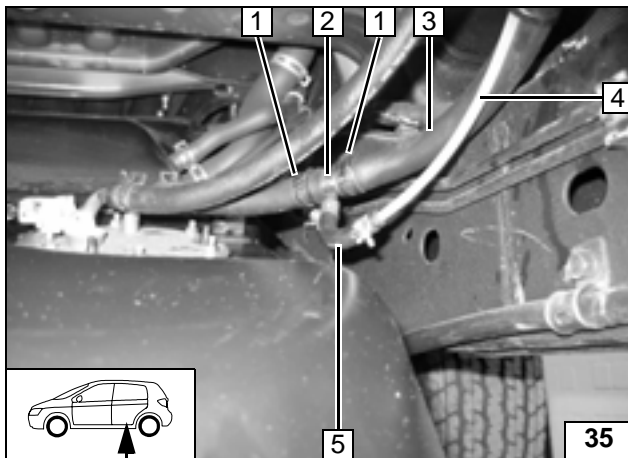

Loosen the fuel tank and lower it to the front.

- 3 Separate the leading fuel line about 150 mm before the tank mounting
- 2 Fuel extractor 12x5x12
- 1 Spring band clamp Ø22 mm
- 4 Residual section of Mecanyl fuel line
- 5 90° moulded hose, Ø10 mm hose clamps [2x]



Install fuel take-off

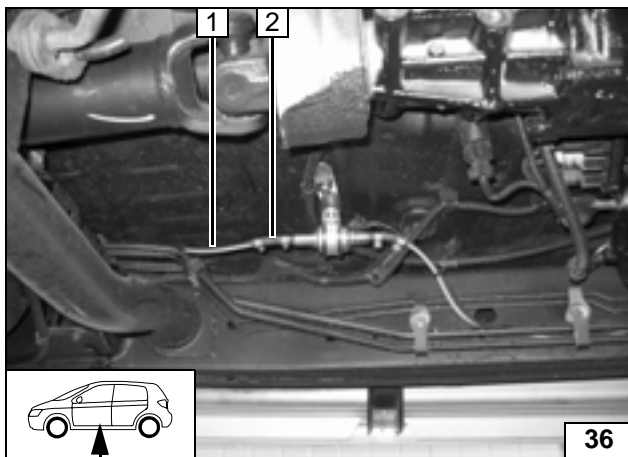

Fuel line from the fuel extractor on the intake side of the metering pump [side without connector].
Check the position of the components; adjust if necessary. Check that these rotate freely.

- 1 Residual section of Mecanyl fuel line
- 2 Hose section, Ø 10 mm hose clamps [2x]



Connecting to the metering pump

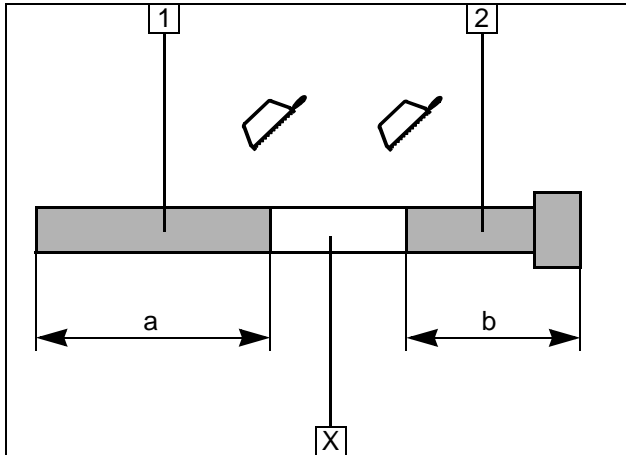
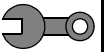

Exhaust System

- 1 Exhaust pipe
a = 580mm
- 2 Exhaust end section
b = 130mm

Dispose of section X

Preparing the exhaust pipe

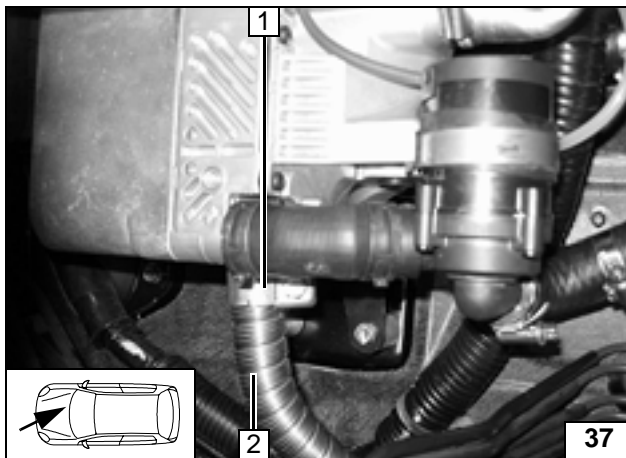

- 1 Hose clamp
- 2 Exhaust pipe

Assembling the exhaust pipe

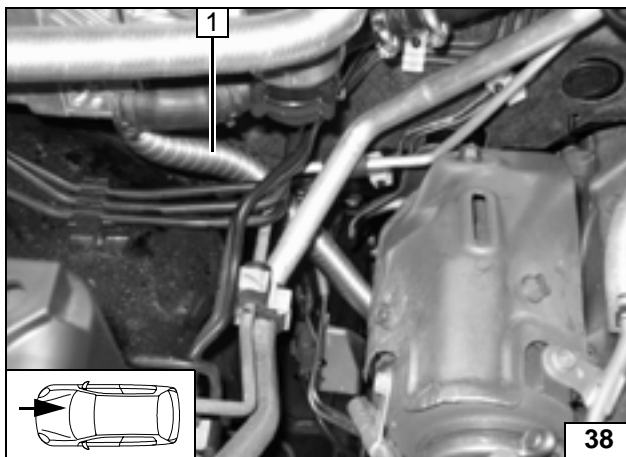

When installing the exhaust pipe 1, ensure sufficient distance from adjacent components.



Assembling the exhaust pipe



Feel the drive

Webasto AG
Postfach 80 - 82132 Stockdorf - Hotline 0 18 05 / 93 22 78
Hotfax (0395) 55 92-353 - <http://www.webasto.de>

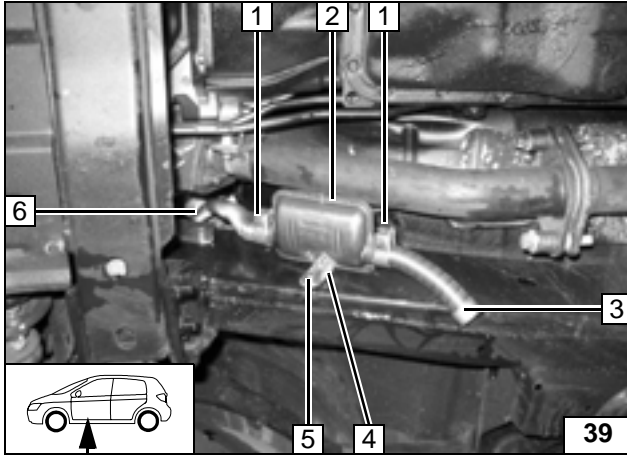

Ensure sufficient distance from adjacent components.

- 1 Hose clamp [2x]
- 2 Silencer, bolt M6x20, flanged nut M6 to angle bracket.
- 3 Exhaust end section
- 4 Angle bracket
- 5 Available bore hole, rivet nut, bolt M6x20, spring washer, body washer, angle bracket
- 6 Exhaust pipe



Assembling the silencer

Final Work

WARNING!

Reassemble disassembled components in reverse order.

Check that all hose lines, hose, spring band clamps and universal clips, and all electrical connections are securely fastened.

Secure all loose lines using cable clip.

Only use manufacturer-approved coolant.

Spray heating unit components with anti-corrosion wax (Tectyl 100K, Order No. 111329).

- Connect battery.
- Start engine, bleed coolant circuit according to the vehicle manufacturer's specifications, top up with coolant.
- Set the time switch.
- Set the manual air conditioning or automatic air conditioning according to the "operating instructions for the end customer".
- Check that the auxiliary heating operates properly, see operating instructions / installation instructions.
- Attach the "Switch off auxiliary heating before re-fuelling" sticker onto the left side of the B-pillar.



Operating instructions for the end customer

Please remove page and add to the vehicle operating instructions.



Before parking the vehicle, make the following settings:

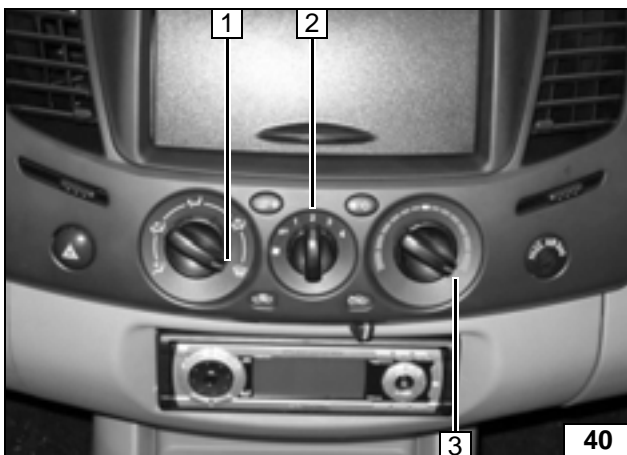

- 1 Air outlet to windscreen
- 2 Blower set to level "1" or "2"
- 3 Temperature to "max."

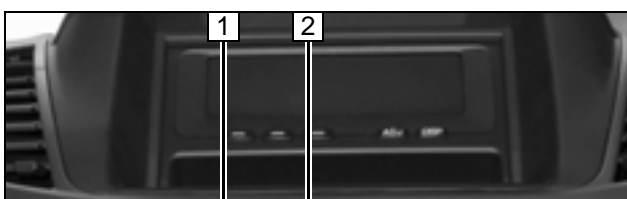

- 1 Air outlet to windscreen
- 2 Blower rpm to 1/3 of the max. rpm
- 3 Temperature to "max."

For vehicles with manual air conditioning

For vehicles with