

# Water Heater Unit



Feel the drive

**Thermo Top C Additional Heater**  00 0002

**Thermo Top P Additional Heater**  00 0104

**Thermo Top E Additional Heater**  00 0003

## Installation Instructions

### Seat Leon

Gasoline

from Model Year 2005

Left-hand drive vehicle

Not with "SEAT Sport" aerodynamics kit



#### **WARNING!**

**Hazard warning:**

**Incorrect installation or repair of Webasto heating systems may cause a fire or result in the emission of carbon monoxide, which can be fatal. Serious or fatal injuries can be caused as a result.**

**Specialist company training, technical documentation, specialized tools and equipment are required to install and repair Webasto heating and cooling systems.**

**NEVER attempt to install or repair Webasto heating or cooling systems if you have not successfully completed the company training and thereby acquired the required technical skills, or if you do not have access to the required technical documentation, tools and equipment needed to carry out correct installation and repairs.**

**ALWAYS follow all Webasto installation and repair instructions and observe all warnings.**

**Webasto does not accept any liability for defects and damage that are attributable to installation by untrained staff.**

## Table of Contents

Validity	2	Preassemble exhaust system	15
Heater Unit/Installation Kit	3	Combustion air	16
Foreword	3	Preparing installation location	17
General Instructions	3	Installing heater unit	18
Special Tools	3	Combustion air connection	22
Explanatory Notes on the Document	4	Fuel Connection	23
Preliminary Work	5	Fuel removal	24
Heater Unit Installation Location	5	Coolant connection	26
Fuse holder and relay K3	6	Final Work	30
Electrical Connections	7	Operating Instructions for End Customer	31
Climatic fan controller	8		
Climatronic fan controller	10		
Remote option (Telestart)	13		
Remote option (Thermo Call)	14		
Preassembling heater unit	15		

## Validity

Manufacturer	Model	Type	EG-BE No./ABE
Seat	Leon	1P	e1 * 2001 / 116 * 0052

Engine type	Engine model	Output in kW	Displacement in cm <sup>3</sup>
BSE	Gasoline	75	1595
BVY	Gasoline	110	1984

Vehicle and engine types, equipment variants and national specifications not listed in these installation instructions have not been tested. However, installation according to these installation instructions may be possible.

The installation location of a digital timer and summer/winter switch should be confirmed with the end customer before installation.

## Heater Unit/Installation Kit

Quantity	Description	Order No.:
1	Retail accessories with desired heater control	See price list
1	Installation kit for Seat Leon Gasoline	1311798A

### Also required

Quantity	Description	VW Order No.:
1	Washer reservoir for vehicles with additional heater	5M0 955 453B

The validity of the part number for the respective vehicle identification number must be checked in the ETKA!

### Also required with Climatronic

Quantity	Description	Order No.:
1	IPCU Kit for Climatronic	9013645A

### Heater unit recommended for the respective vehicle class:

Vehicle	Heater unit
Compact car	Thermo Top E
Mid-size car, station wagon	Thermo Top C
Full-size car, van, offroader	Thermo Top P

The selection of the heater unit is based on the passenger compartment size of the vehicle and the level of comfort required by the customer!



## Foreword

The installation instructions apply to the Seat Leon vehicles with a Gasoline engine  
 - For the validity, see page 2 - from model year 2005 and later, assuming technical modifications to the vehicle do not affect installation, any liability claims excluded. Depending on the vehicle version and equipment, modifications may be necessary during installation with respect to these installation instructions.

However, the stipulations in the "installation instructions" and "operating and maintenance instructions" for the *Thermo Top C/P/E* must always be observed.

The corresponding rules of technology and any information from the vehicle manufacturer should be observed during the installation work.

## General Instructions

Installation should be carried out according to the general, standard rules of technology. Unless specified otherwise, fasten hoses, lines and wiring harnesses to original vehicle lines and wiring harnesses using cable ties.

Sharp edges should be fitted with edge protectors (split open plastic hose).

Spray unfinished body areas, e.g. drilled holes, with anti-corrosion wax (Tectyl 100K, Order No. 111329).

## Special Tools

- Torque wrench for 2.0 - 10 Nm
- Hose clamping pliers
- Metric Thread-Setter Kit

**Explanatory Notes on Document**

To provide you with a quick overview of the individual working steps, you will find an identification mark on the outside top right corner of the page in question.

**Mechanical work**



**Electrical connection**



**Coolant connection**



**Fuel connection**



**Exhaust system**

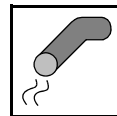

**Combustion air**



Special features are highlighted using the following symbols:



Specific risk of injury or fatal accidents.



Specific risk of damage to components.



Specific risk of fire or explosion.



Reference to general installation instructions of Webasto components or to the manufacturer's vehicle-specific documents.



Reference to a special technical feature.

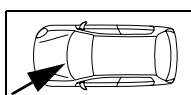
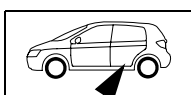

The arrow in the vehicle icon indicates the position on the vehicle and the viewing angle.

## Preliminary Work

### WARNING!

- Open the fuel tank cap, ventilate the tank.
- Close the tank cap again.
- Depressurize the cooling system.
- Copy the factory number from the original type label to the duplicate type label.
- Remove years that do not apply from the duplicate label.
- Attach the duplicate label (type label) in the appropriate place.
- Disconnect the battery "earth" or "ground" connection.
- Only 2.0 FSI: Remove the air filter together with the intake hose.
- Remove the battery
- Remove the battery carrier
- Remove the engine cover
- Remove the right front wheel
- Remove the front section of the right front wheel well trim
- Remove the underride protection
- Remove the bumper
- Remove the right-hand underbody trim
- Remove the right rear seat
- Open the right-hand fuel sender service lid
- Remove the footwell trim on the driver's side
- Remove the lower instrument panel trim on the driver's side
- Only vehicles with Climatronic: Remove the footwell trim on the front passenger side

Please remove page 31 "Operating instructions for the end customer" and add this to the vehicle operating instructions.

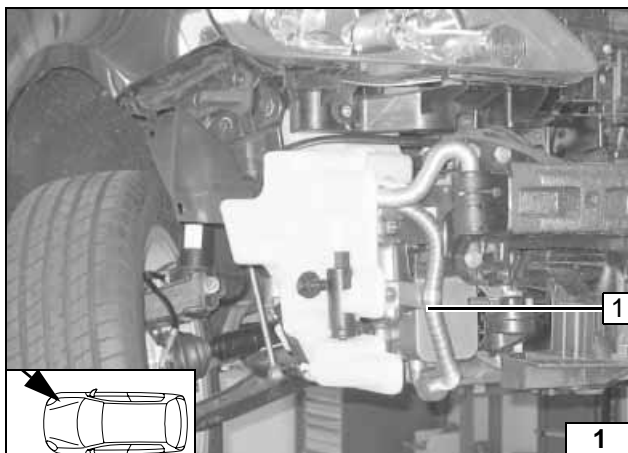

### Heater unit installation location

- 1 Heater unit

Installation location

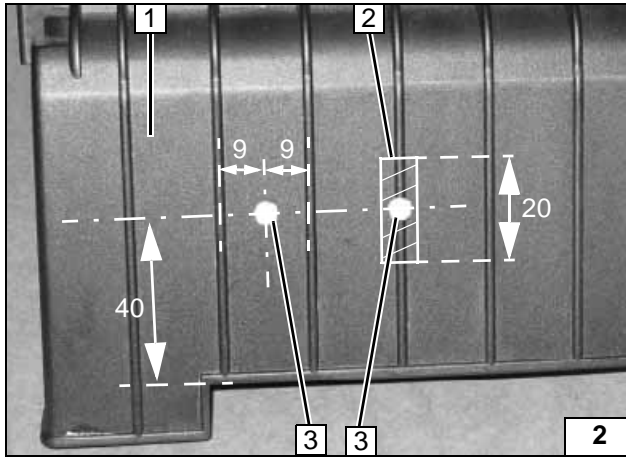

## Fuse holder and relay K3

Countersink holes **3** from behind for M5 countersunk head screws.

- 1** Cover of fuse/relay carrier in engine compartment
- 2** Cut away bar in shaded area
- 3** Drill 5.0 mm dia. hole [2x]



**Holes for fuse holder and relay K3**

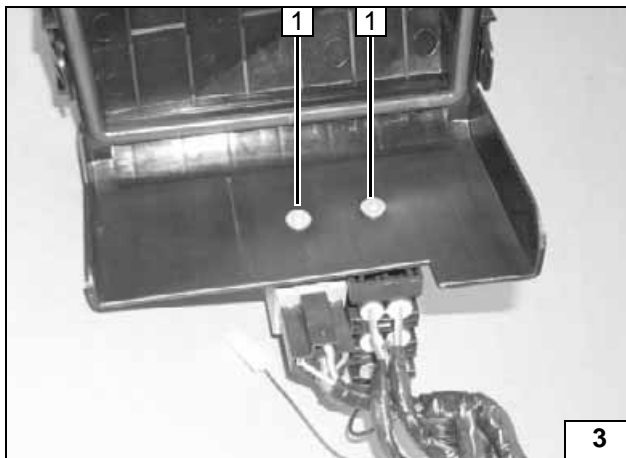

- 1** M5x12 countersunk head screw [2x]

**Installing fuse holder and K3 relay**

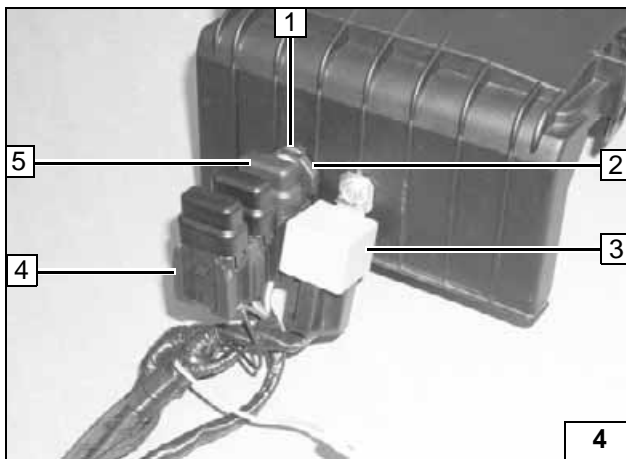

On vehicles with Climatronic, replace 25 A fuse F3 with 3 A fuse.

- 1** Large diameter washer (between cover and retaining plate)
- 2** Retaining plate, M5 flanged nut
- 3** K3 relay, M5 flanged nut
- 4** Fuse holder
- 5** F3 fuse



**Installing fuse holder and relay K3**

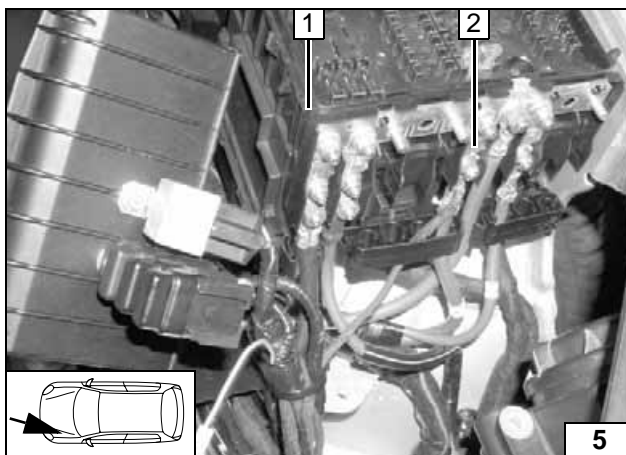

Connect brown (br) ground wire to original vehicle ground support point.

- 1** Fuse/relay carrier
- 2** Red (rt) positive wire



**Connecting positive and ground wire**



**Electrical Connections**

**Wiring harness of heater unit**

Route the wiring harness of the heater unit along the original vehicle wiring up to the right-hand headlight.

**Fuse holder**

- 1 Relay K3
- 2 Fuse holder
- 3 Route wiring harness of heater control, fan controller and metering pump in cable duct to firewall.

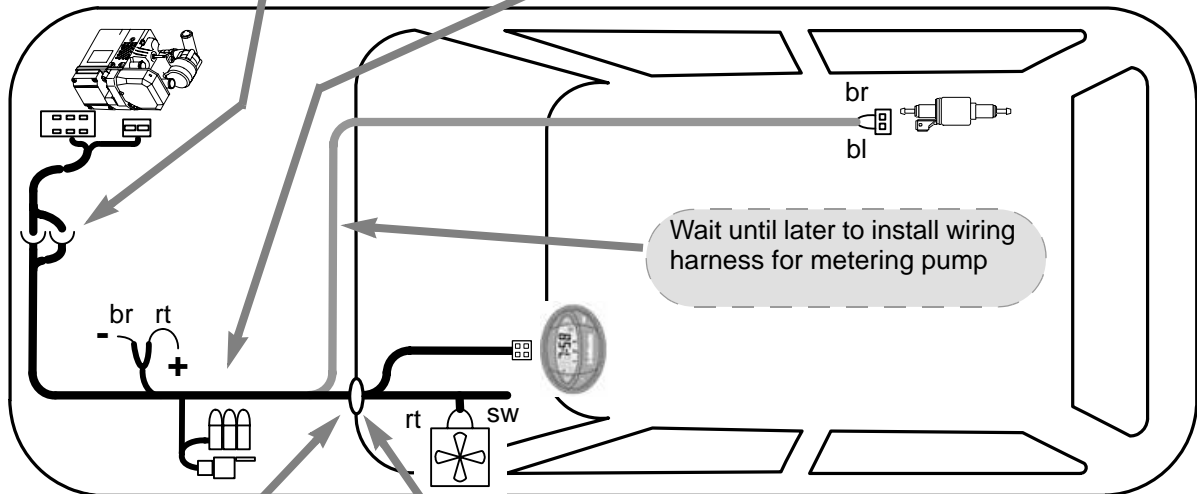
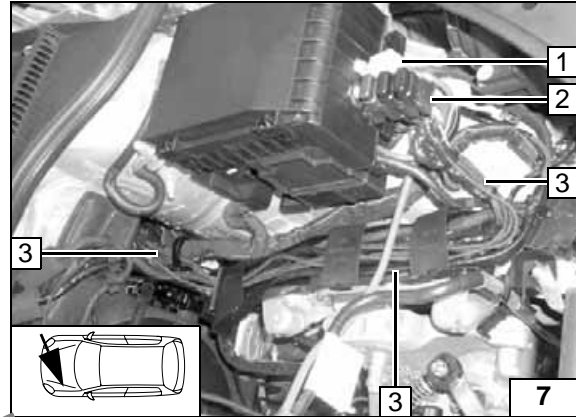
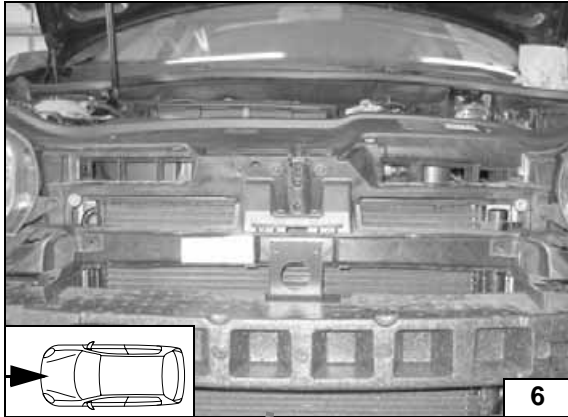
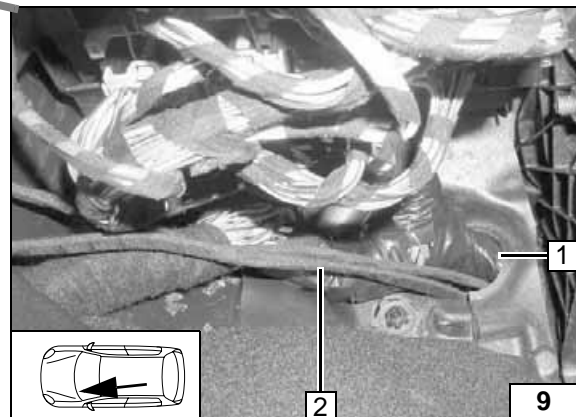
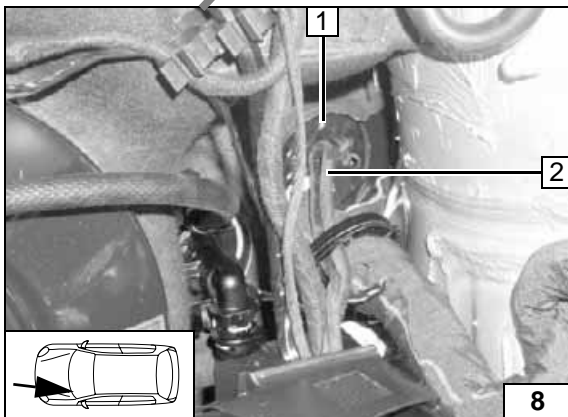

Diagram of wiring harness routing for all equipment



**Wiring harness pass through**

- 1 Original vehicle wiring harness pass through
- 2 Wiring harnesses for fan controller and heater control

**Wiring harness pass through**

- 2 Original vehicle wiring harness pass through
- 1 Wiring harnesses for fan controller and heater control

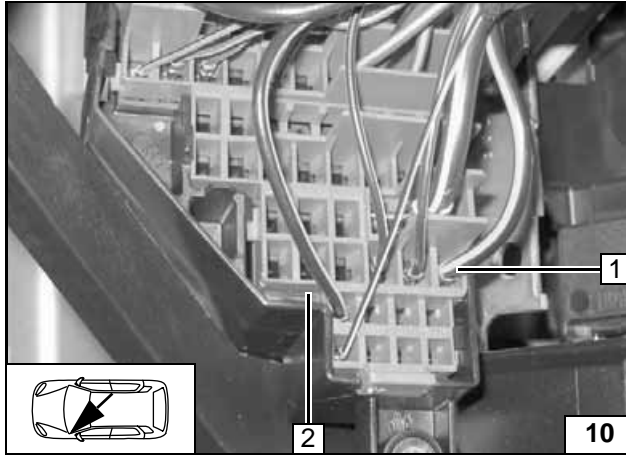

## Climatic fan controller

2 **Uncrimping wire**

- 1 Unlock 40 A fan fuse, remove 4 mm<sup>2</sup> black (sw) wire
- 2 Fuse carrier

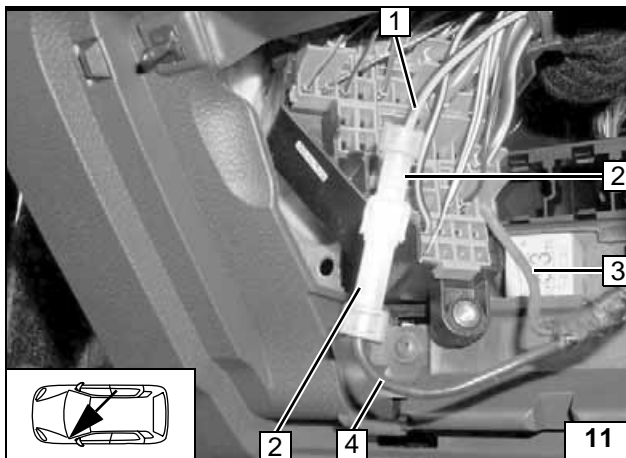

Produce connections as shown in wiring diagram.

**Connecting wires**

- 1 4 mm<sup>2</sup> black (sw) wire
- 2 AMP/housing
- 3 Red (rt) wire to K3/87a
- 4 Black (sw) wire from K3/30



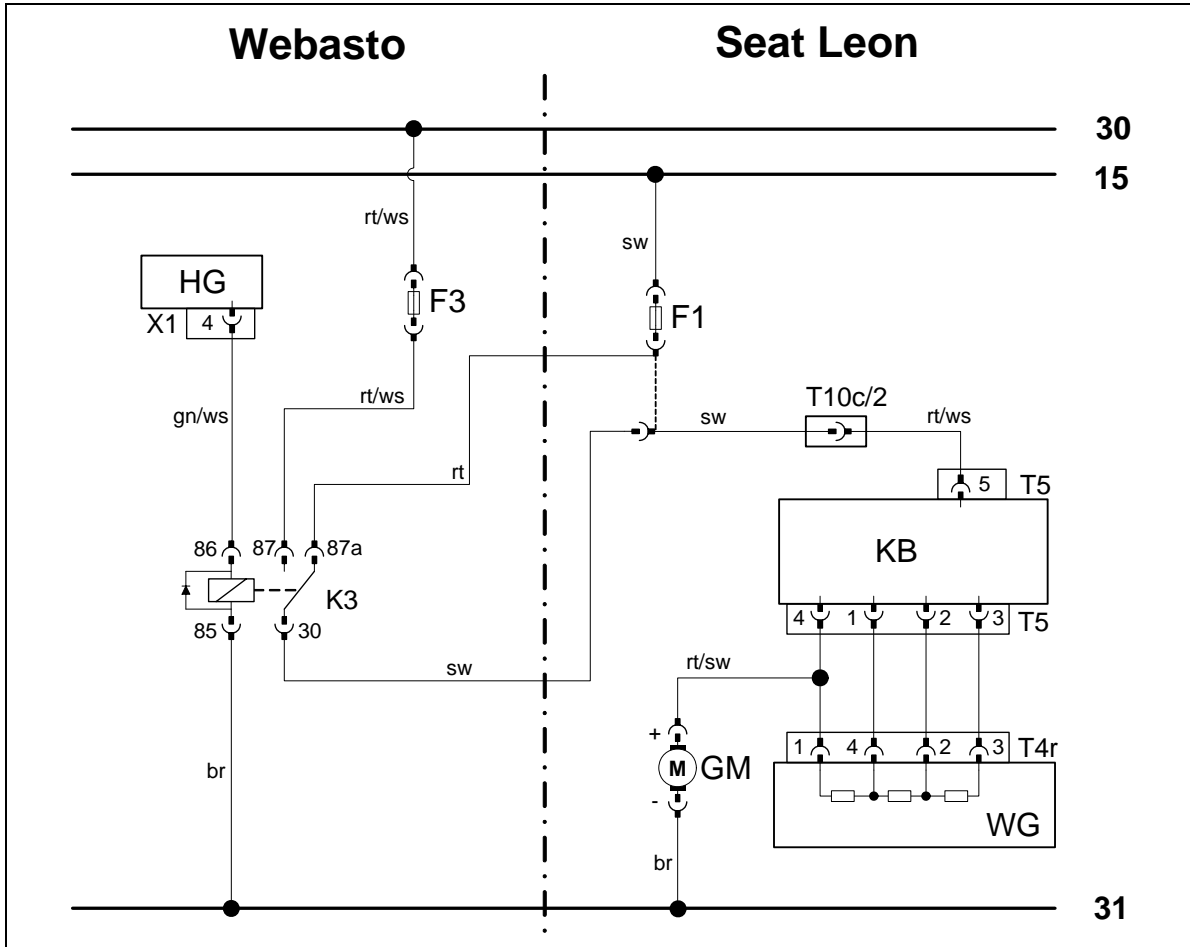

Climatic wiring diagram

Webasto components		Components of Seat Leon		Colors and symbols	
HG	Heater unit TT-C/E	KB	Climatic control unit	rt	red
X1	6-pin connector	WG	Resistor group	ws	white
F3	Fuse, 25 A	F1	Fuse 40A	sw	black
K3	Fan relay	GM	Fan motor	br	brown
				gn	green
					Insulate wire ends and tie back
				X	Cutting point
					Wiring colors may vary.

Legend

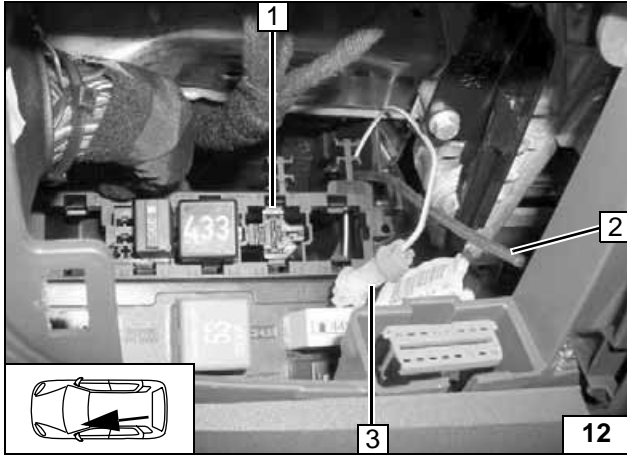

**Climatronic fan controller**

Position of free sockets dependent on vehicle equipment!

- 1 IPCU socket
- 2 Red (rt) and black (sw) wire from IPCU
- 3 Green/white (gn/ws) wire of IPCU/86 with connector

**IPCU socket**

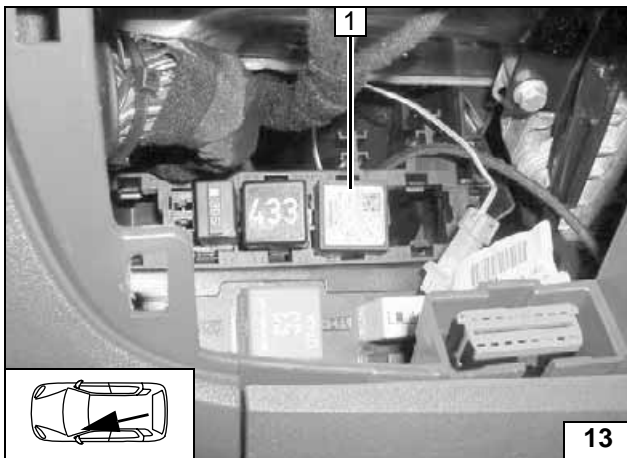

Brown (br) wire from IPCU/85 to original vehicle ground point. Produce connections as shown in wiring diagram.

- 1 IPCU

**Connecting wires**

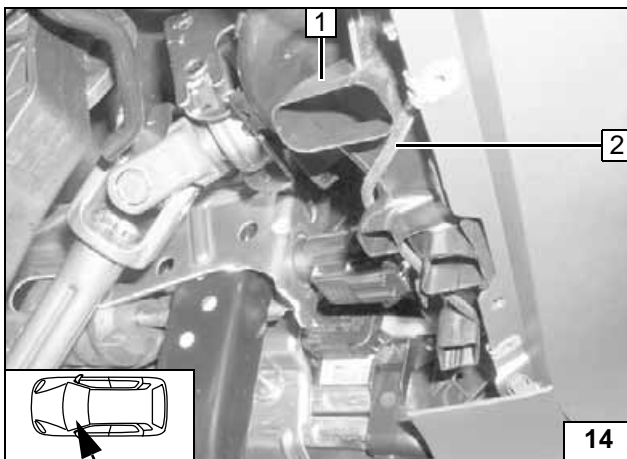

- 1 Air duct
- 2 IPCU wiring harness

**Routing wiring harness for IPCU to right**

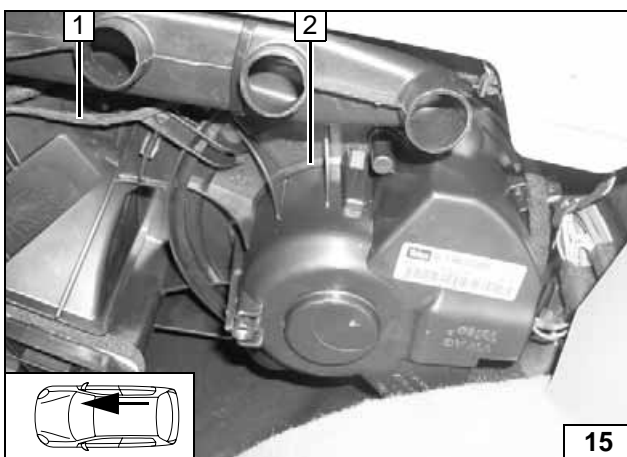

- 1 IPCU wiring harness
- 2 Fan unit

**Routing wiring harness to fan unit**

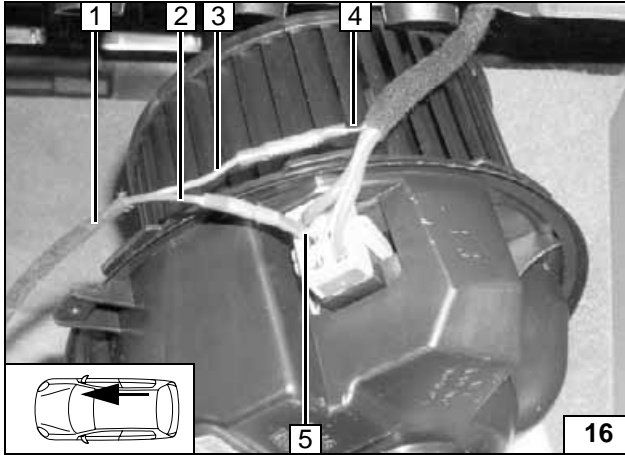

If necessary, disconnect fan unit in accordance with manufacturer's instructions. Produce connections as shown in wiring diagram.

- 1 Wiring harness from IPCU
- 2 Black/white (sw/ws) wire from IPCU/A
- 3 Red (rt) wire from IPCU/E
- 4 Black/white (sw/ws) wire from Climatronic control unit
- 5 Black/white (sw/ws) wire to connector



**Connect-  
ing wires**

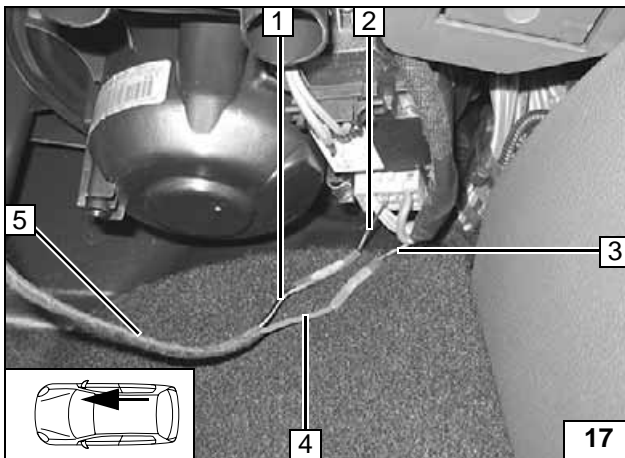

Picture shows version without having to disconnect fan unit.

- 1 Black/white (sw/ws) wire from IPCU/A
- 2 Black/white (sw/ws) wire to connector
- 3 Black/white (sw/ws) wire from Climatronic control unit
- 4 Red (rt) wire from IPCU/E
- 5 Wiring harness from IPCU



**Connect-  
ing wires**

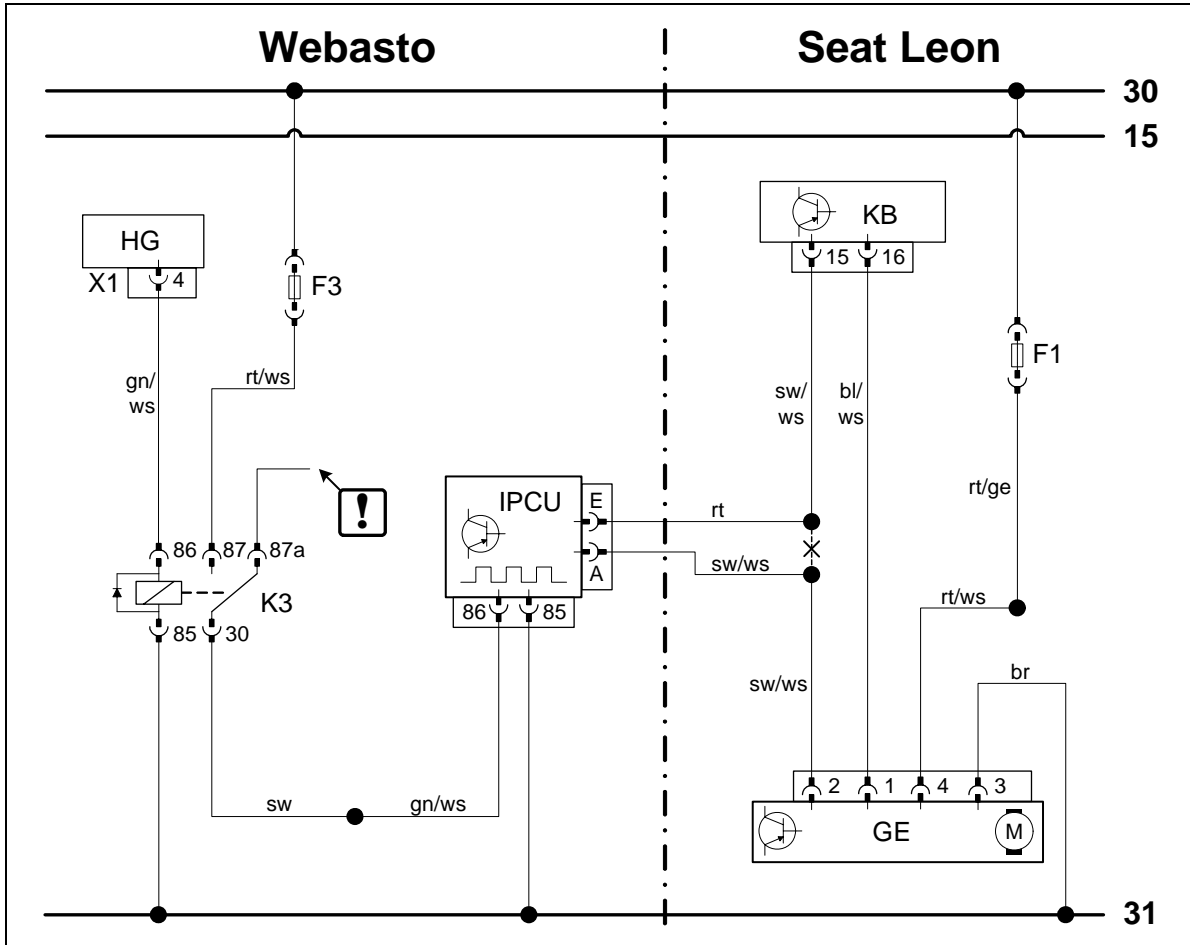

Climatronic wiring diagram

Webasto components		Vehicle components		Colors and symbols	
HG	Heater unit TT-C/E	KB	Climatronic control unit	rt	red
X1	6-pin heater unit connector	ge	Fan unit	ws	white
K3	Fan relay	F1	Fuse 40A	sw	black
F3	Fuse (25 A replaced with 3 A)			br	brown
IPCU	Pulse width modulator			gn	green
<b>IPCU adjustment values</b>				ge	yellow
Voltage: 8 V				bl	blue
Frequency: 400 Hz					Insulate wire end and tie back
Duty cycle: 30 %					
Function: High-side				X	Cutting point

Legend

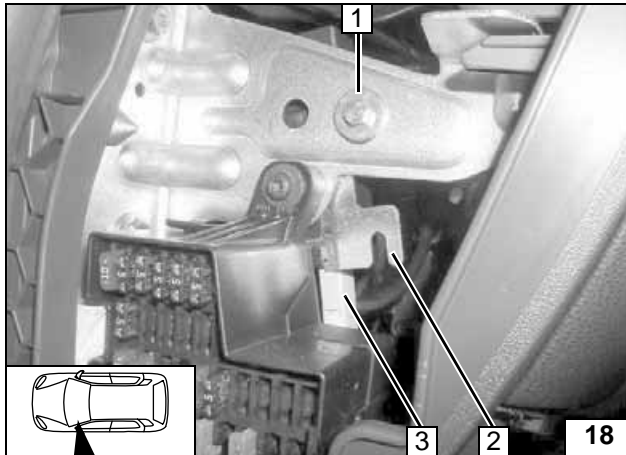
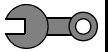

## Remote option (Telestart)

- 1 M6x20 bolt, large diameter washer, flanged nut
- 2 Telestart bracket, hole drilled out to 6.5 mm dia.
- 3 Antenna connector



Installing receiver

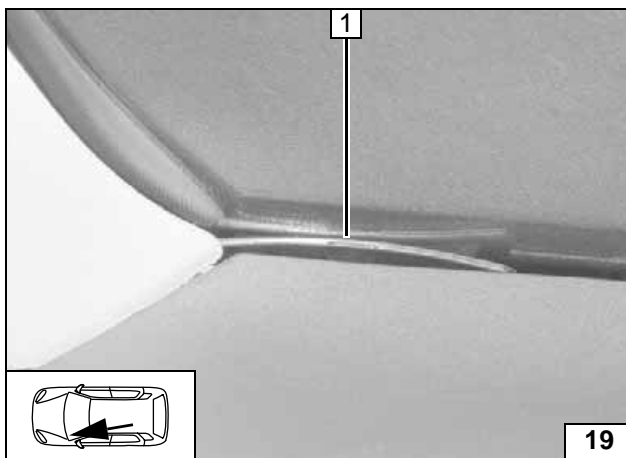

- 1 Antenna



Installing antenna

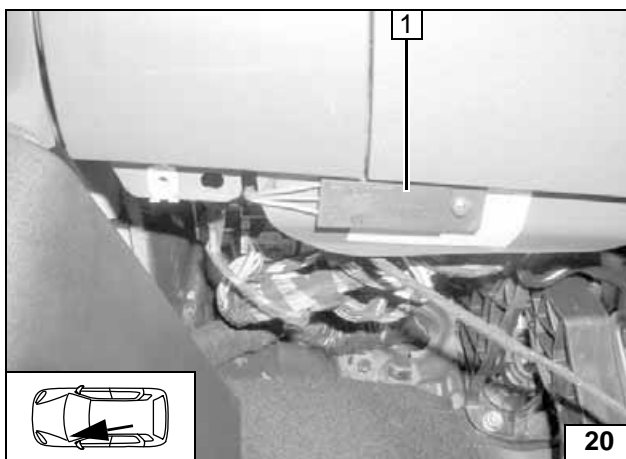

## Temperature sensor only with HTM 100

- 1 Fasten temperature sensor with suitable means



Installing temperature sensor

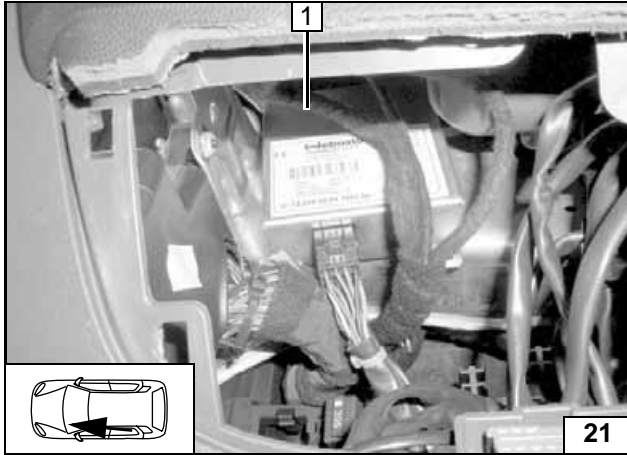
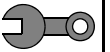

## Remote option (Thermo Call)

1 Fasten receiver with suitable means



Installing receiver

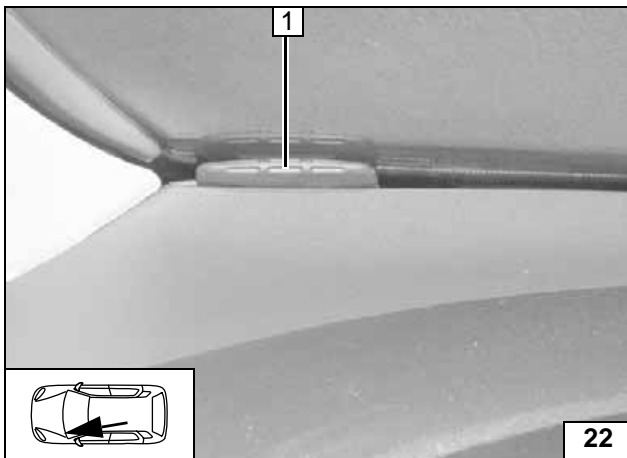

1 Antenna

Installing antenna

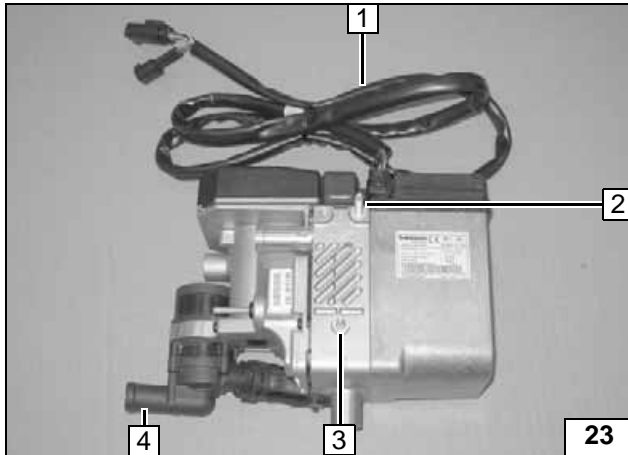
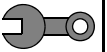

## Preassembling heater unit

Ejot stud, tightening torque 10 Nm!

- 1 Adapter wiring harness connected
- 2 Long E-jot screw
- 3 Short E-jot screw
- 4 Replace circulating pump cover with cover with straight inlet



**Preassembling heater unit**

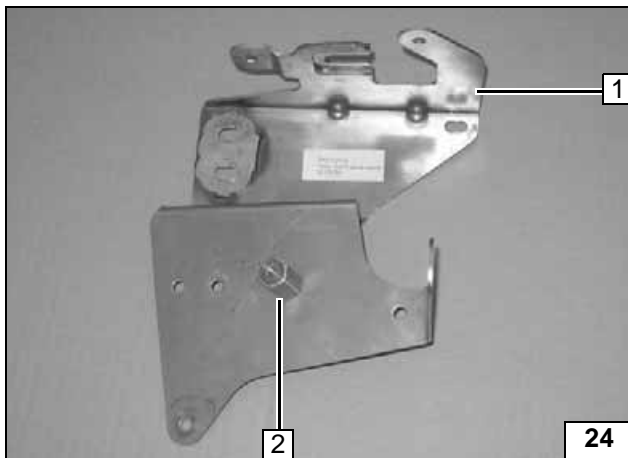

- 1 Bracket
- 2 M6x30 spacer nut, M6x16 bolt, spring lock-washer

**Preassembling bracket**

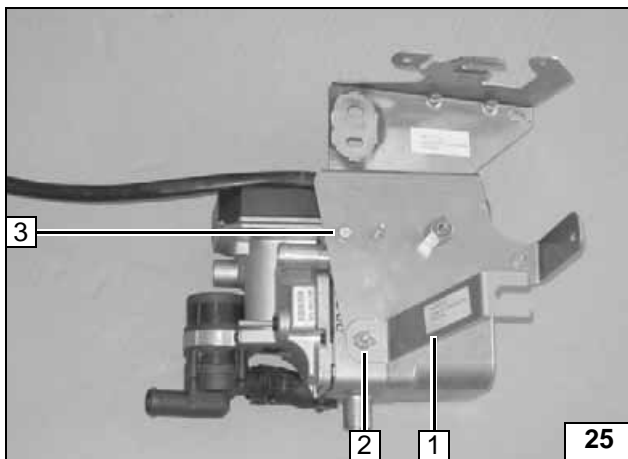

Ejot screw bolt, tightening torque 10 Nm!

- 1 Strut
- 2 Flanged nut, loosely mounted
- 3 E-jot screw, washer between heater unit and bracket



**Preassembling heater unit**

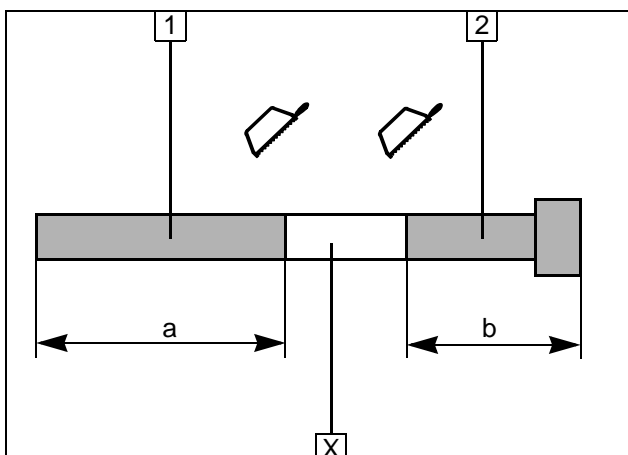

## Preassemble exhaust system

- 1 Exhaust pipe  
a = 520 mm
- 2 Exhaust end section  
b = 90 mm

Discard section X

**Preparing exhaust pipe**

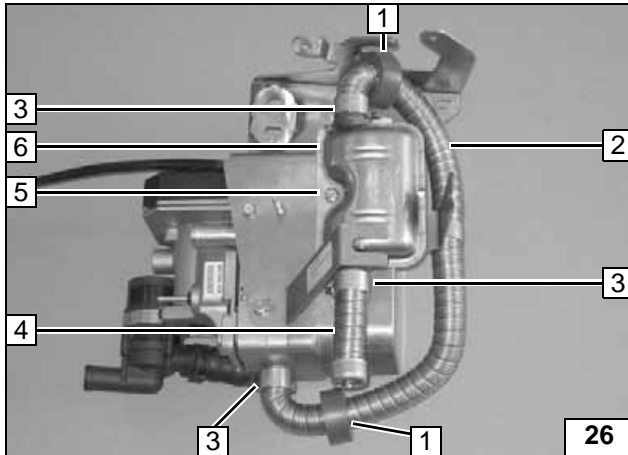
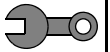

Shape exhaust pipe as shown in picture 26 and 27

- 1 Red (rt) rubber profile [2x]
- 2 Exhaust pipe
- 3 Hose clamp [3x]
- 4 Exhaust end section
- 5 M6x16 bolt, spring lockwasher
- 6 Exhaust muffer



**Preassembled exhaust system**

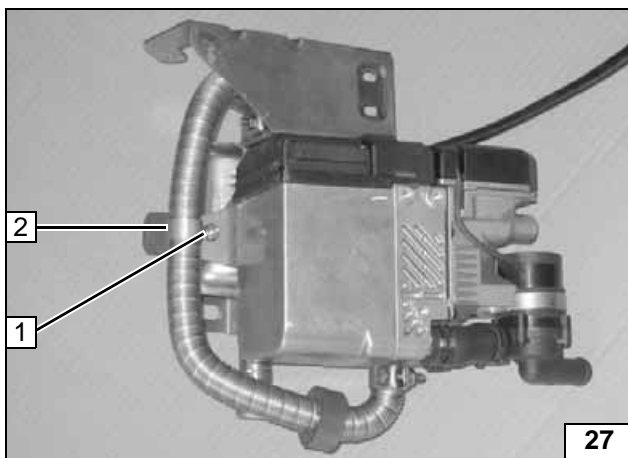

- 1 M6x20 bolt, flanged nut
- 2 P-clamp

**Preassembling exhaust system**

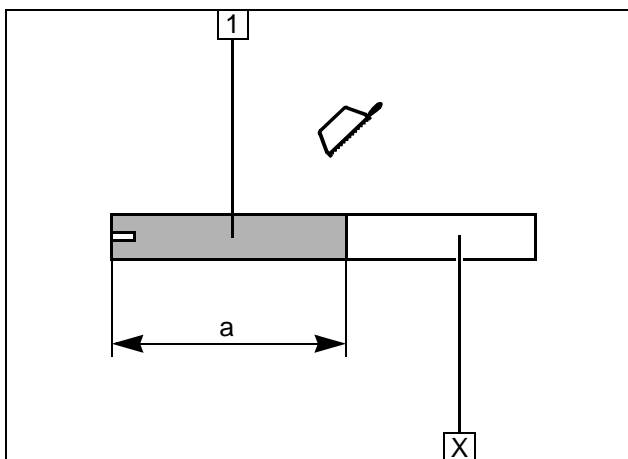

## Combustion air

- 1 Combustion air pipe  
a = 650 mm

Discard section X

**Cutting combustion air pipe to length**

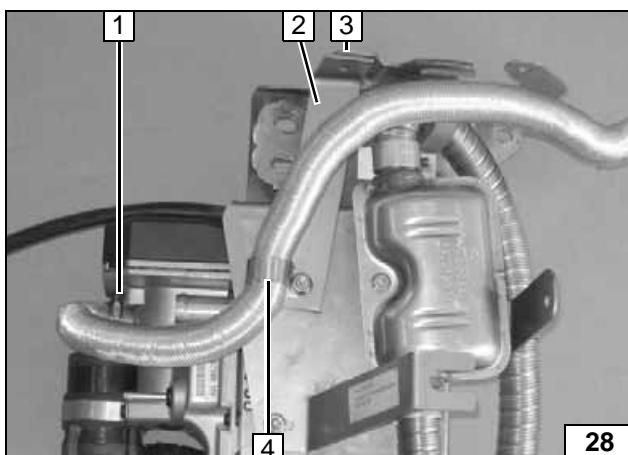

Shape combustion air pipe as shown in picture. Align strut 2 in accordance with hole pattern position 3.

- 1 Hose clamp
- 4 P-clamp, M6 flanged nut



**Preassembling combustion air pipe and strut**



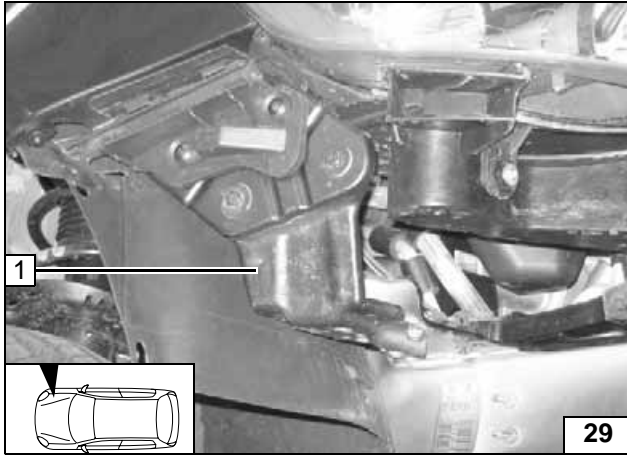
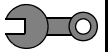

## Preparing installation location

Existing screws and nut will be reused!

1 Cross member



Removing washer reservoir and cross member

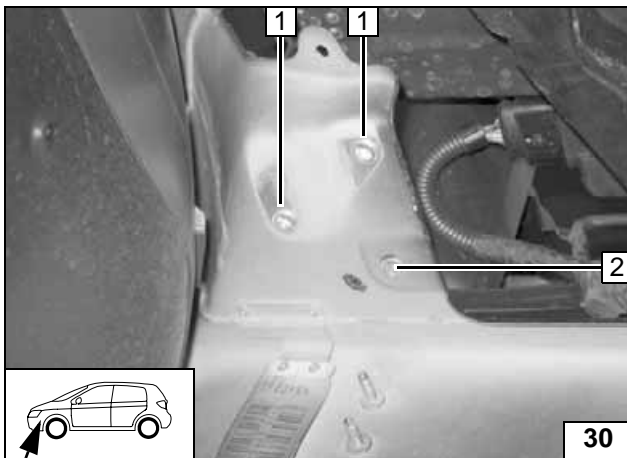

Insert rivet nut **2** only loosely, but do not rivet in.

1 Holes drilled out to 9 mm dia., M6 rivet nut [2x]

2 M6 rivet nut centered in oblong hole



Installing rivet nuts

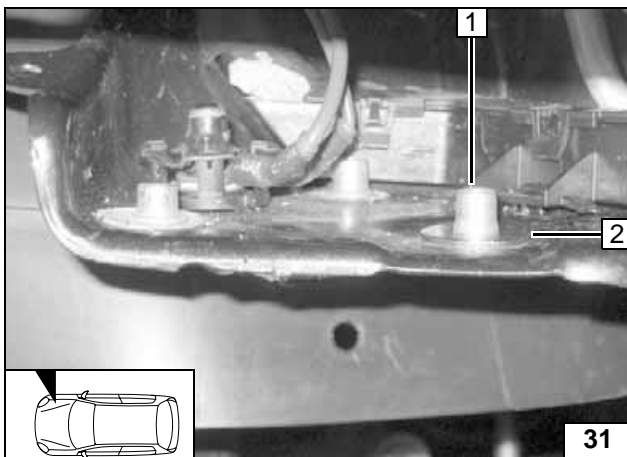

Drill out large diameter washer from inside 7 mm dia. to 9 mm.

1 30/2 rivet nut, riveted in

2 Large diameter washer, drilled out



Installing rivet nut

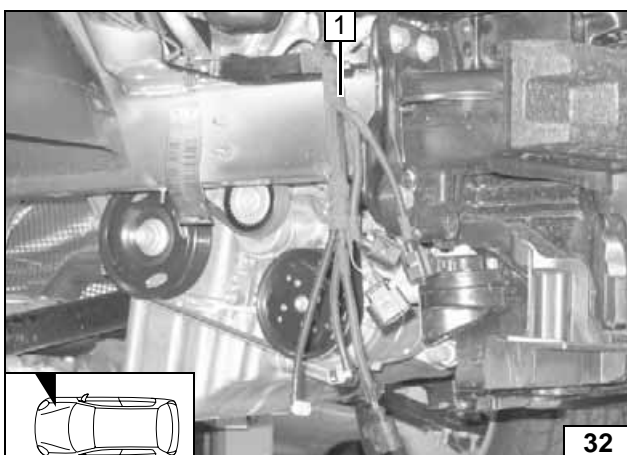

Disconnect wiring harnesses **1** for washer reservoir, horn and front fog lights and wrap individually with insulating tape.



Installing wiring harnesses

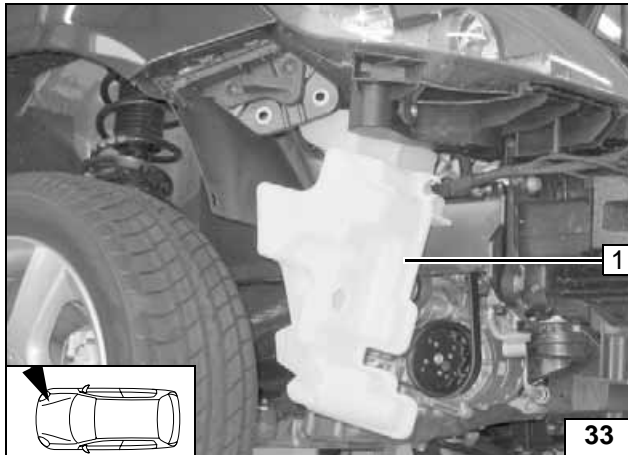
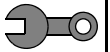

## Installing heater unit

Position replacement washer reservoir as shown.

- 1 Washer reservoir



Installing washer reservoir

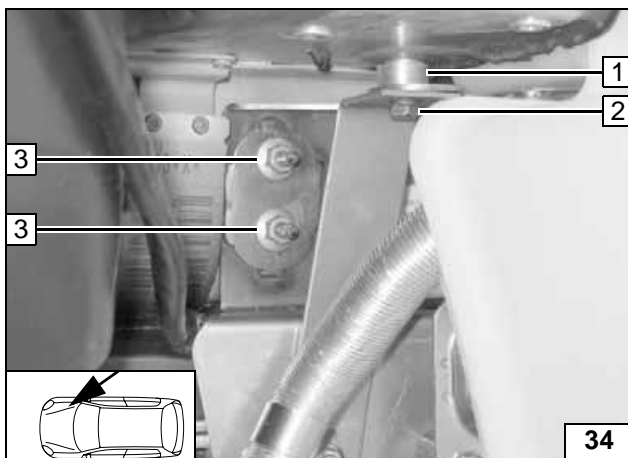

Loosely mount bolt 2 and nuts 3!

- 1 5 mm shim
- 2 M6x30 bolt, spring lockwasher
- 3 Original vehicle nut [2x]



Installing heater unit

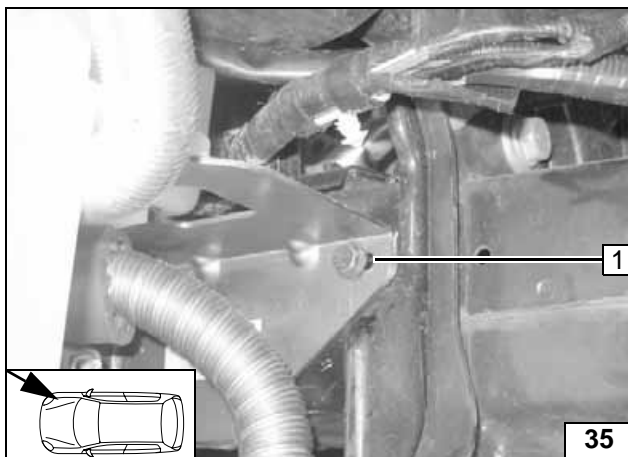

Loosely mount original vehicle bolt 1.



Installing heater unit

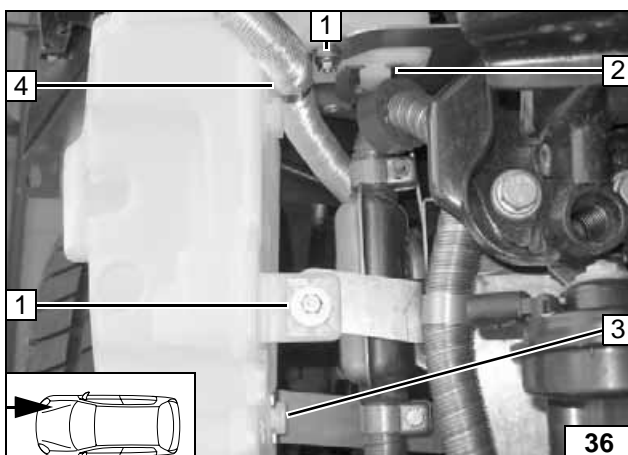

Loosely mount bolts at position 1.

- 1 M6x20 bolt, large diameter washer, flanged nut [2x each]
- 2 Washer reservoir inserted in bracket
- 3 Washer reservoir inserted in strut
- 4 Combustion air pipe, p-clamp



Installing washer reservoir

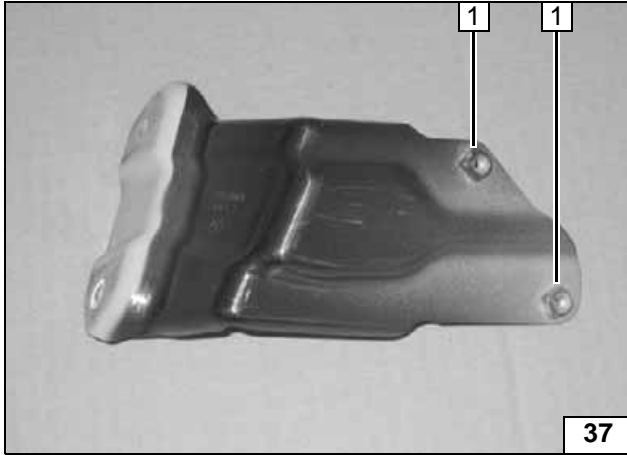
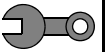

1 Drill out nut to 7 mm dia. [2x]

Preparing cross member

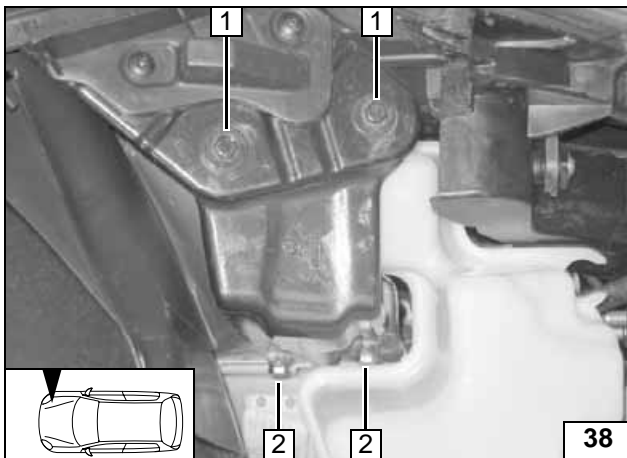

1 Original vehicle bolts [2x]  
2 M6x20 bolt, spring lockwasher [2x each]

Installing cross member

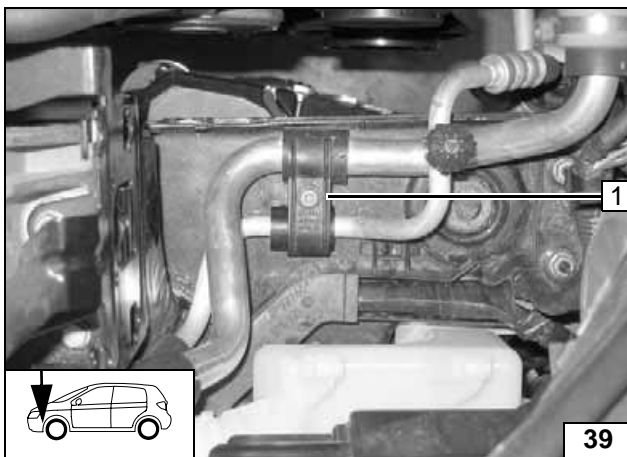

Bracket 1 will be reused.

Removing bracket for A/C line

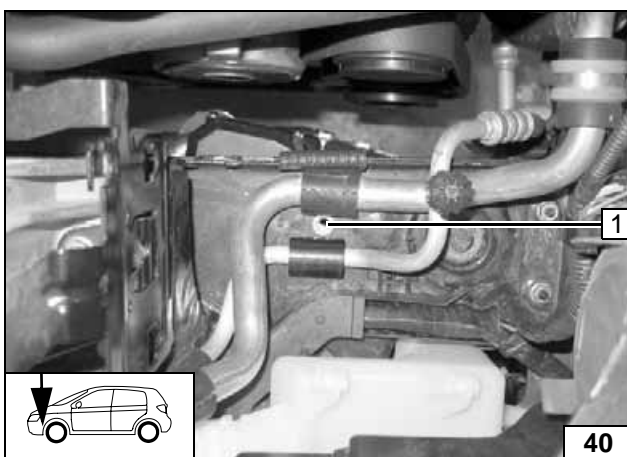

1 9 mm dia. hole, M6 rivet nut



Installing rivet nut

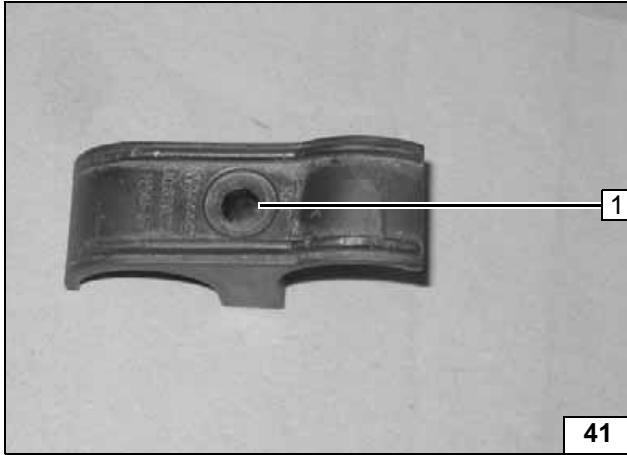
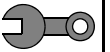

1 6.5 mm dia. hole

Drilling out bracket

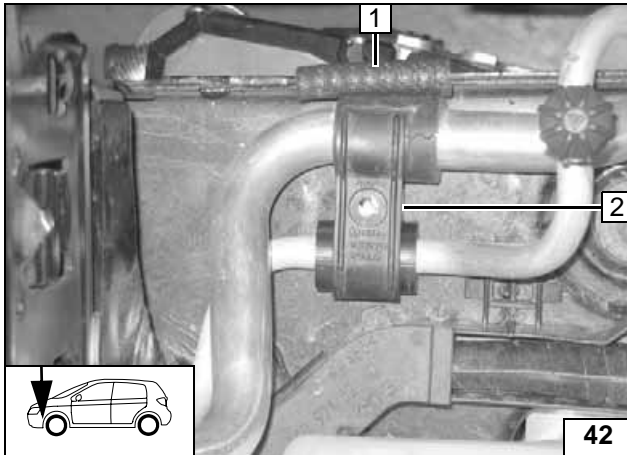

1 50 mm edge protection  
2 Bracket laid on loosely

Installing bracket

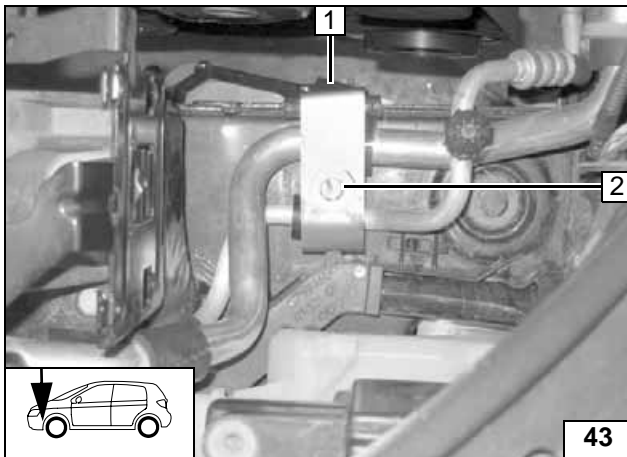

Loosely mount bolt 2!

1 Strut  
2 M6x50 bolt, spring lockwasher, large diameter washer



Installing strut

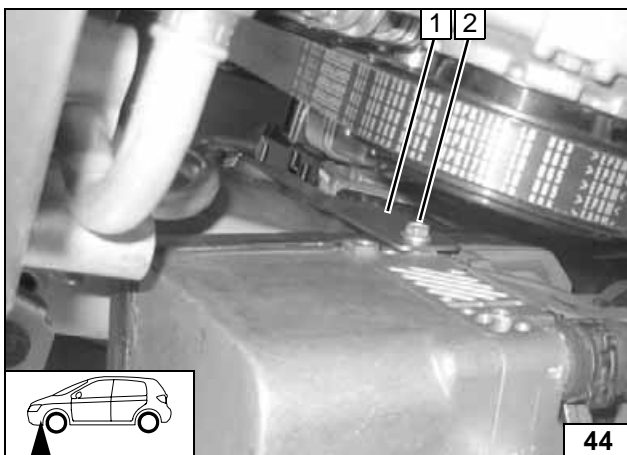

Loosely mount E-jot screw 2.

1 Strut  
2 E-jot screw



Installing strut

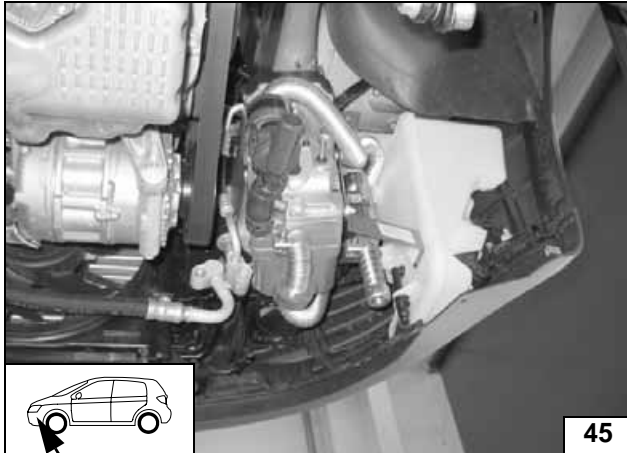
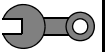

Test mounting of bumper. Check position of all components and adjust if necessary. Check that they have free clearance.



**Aligning and fastening component**

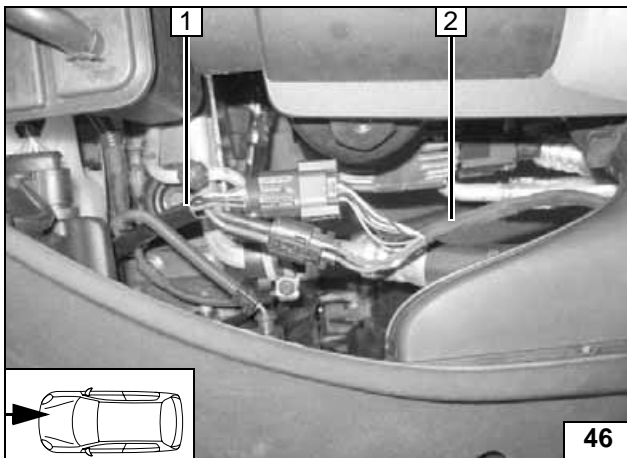

- 1 Adapter wiring harness to heater unit
- 2 Wiring harness of heater unit

**Connecting wiring harnesses**



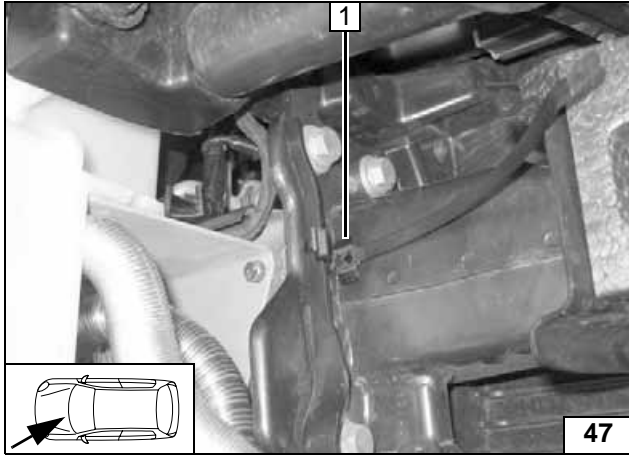
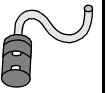

**Combustion air connection**

1 Clip-type cable tie in original vehicle hole

**Cutting combustion air pipe to length**

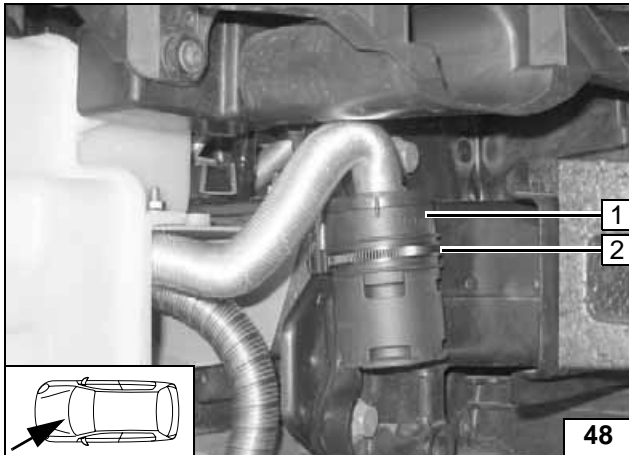

First close clip-type cable tie **2**, then push in combustion-air intake muffler **1**.



**Installing combustion-air intake muffler**



**Fuel Connection**

**CAUTION!**

Open the vehicle's fuel tank cap, ventilate the tank and then re-close the tank lock.

Catch any fuel running off with an appropriate container.

Install fuel line and metering-pump wiring harness so that they are protected against stone impact. Unless specified otherwise, always fasten using cable ties.

Mount the fuel line and wiring harness with rub protection on sharp edges.

**WARNING!**

The fuel line and wiring harness are routed to the metering pump in as shown in the wiring harness routing diagram.

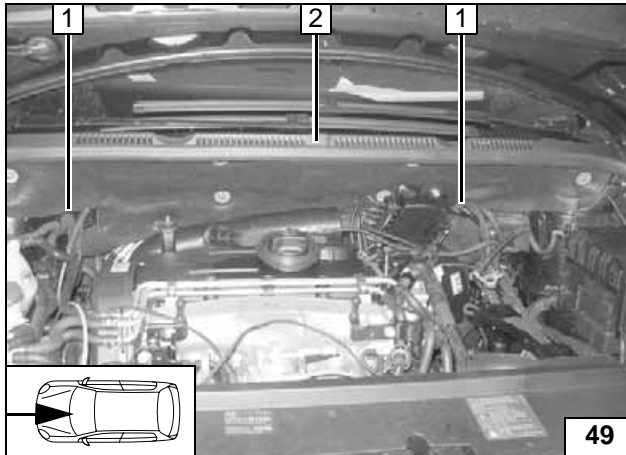

Route wiring harness of metering pump in coolant reservoir to right. Ensure freedom of movement of wiper linkage.

- 1 Metering pump wiring harness
- 2 Coolant reservoir cap detached



**Installing wiring harness of metering pump**

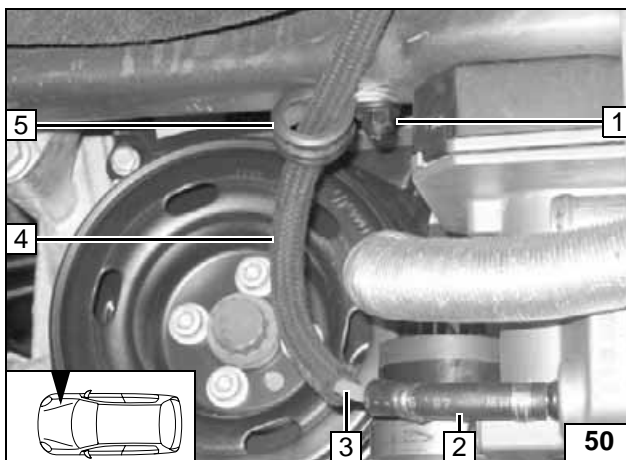

- 1 Plastic nut on original vehicle stud bolt
- 2 Hose section, 10 mm dia. hose clamps [2x]
- 3 Fuel line
- 4 Cloth-reinforced protective hose cut to length of 1,100 mm
- 5 Rubber-coated pipe clamp, 15 mm dia.

**Installing lines**

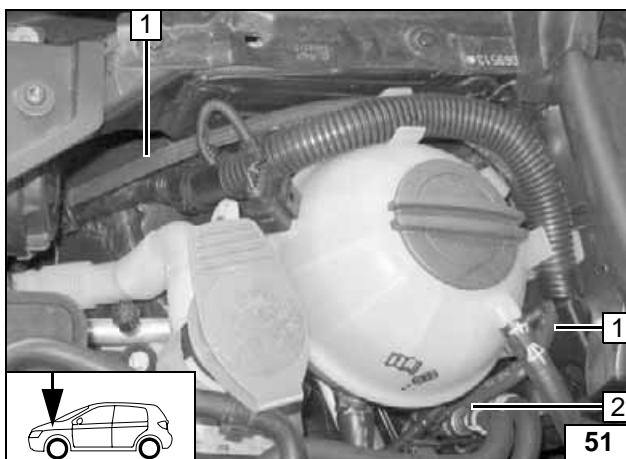

Route Mecanyl fuel line 1 and wiring harness of metering pump to underbody in original vehicle line duct 2.



**Installing lines**

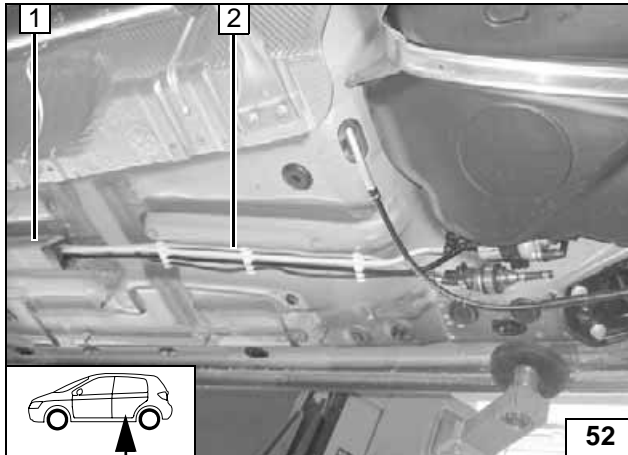

Route mecanyl line and wiring harness of metering pump along original vehicle lines 2 to fuel tank!

- 1 Line duct



**Installing lines**

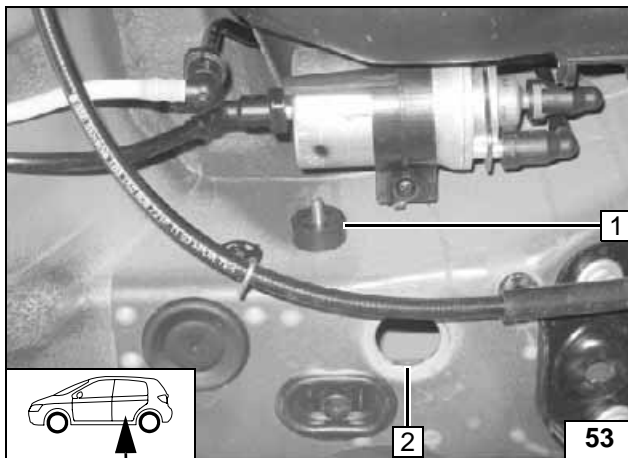

- 1 Silentblock, large diameter washer, M6 flanged nut
- 2 Remove sealing plug

**Installing noise isolation mount**

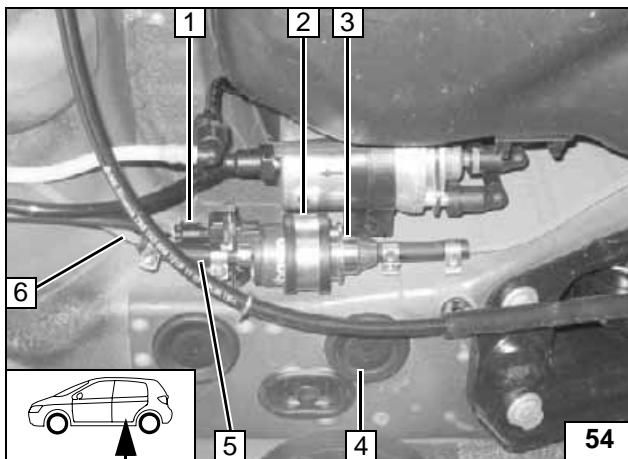

- 1 Wiring harness of metering pump, connector mounted
- 2 Rubber-coated p-clamp, flanged nut
- 3 Metering pump
- 4 Plug remounted
- 5 Hose section, 10 mm dia. hose clamp [10x]
- 6 Fuel line



**Installing metering pump**

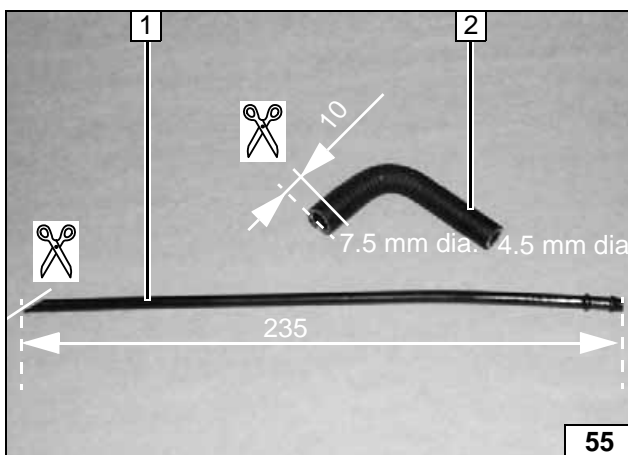

## Fuel removal

- 1 Standpipe
- 2 Molded hose

**Cutting standpipe and molded hose to length**



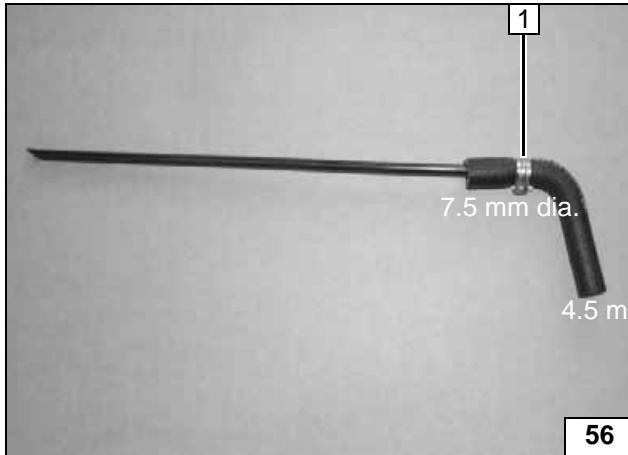

10 mm dia. clamp **1** centered between beads at end of standpipe.



**Preassembling standpipe and molded hose**

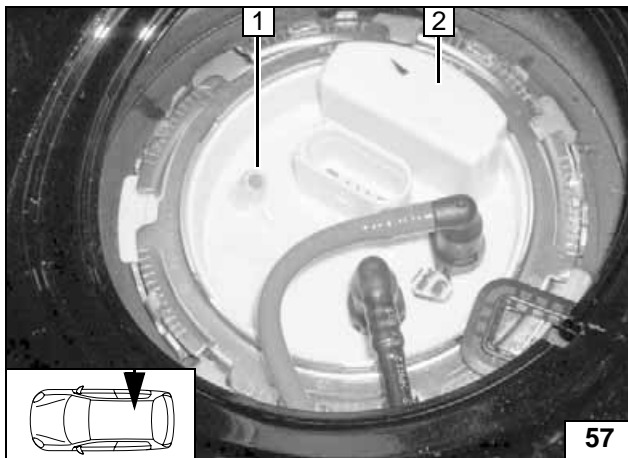

Cut 3 mm off blind plug.

- 1** Tip cut off blind plug
- 2** Fuel sender



**Cutting off blind plug**

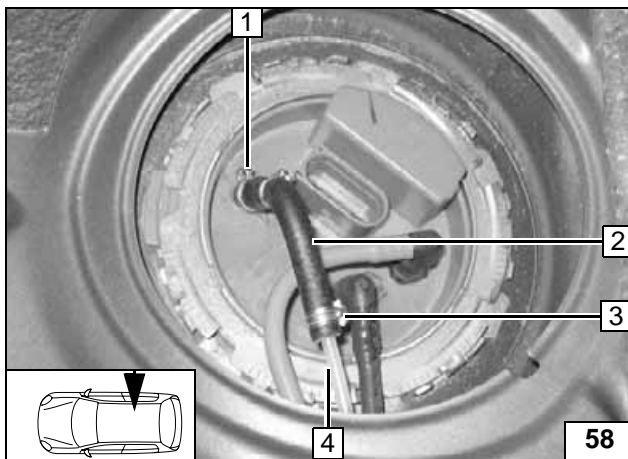

Align curved standpipe toward rear right to prevent impairment of fuel gauge.

- 1** 13.5 mm dia. clamp
- 2** Molded hose with standpipe
- 3** 10 mm dia. clamp
- 4** Remaining piece of **mecanyl** line



**Connection to fuel-tank sending unit**

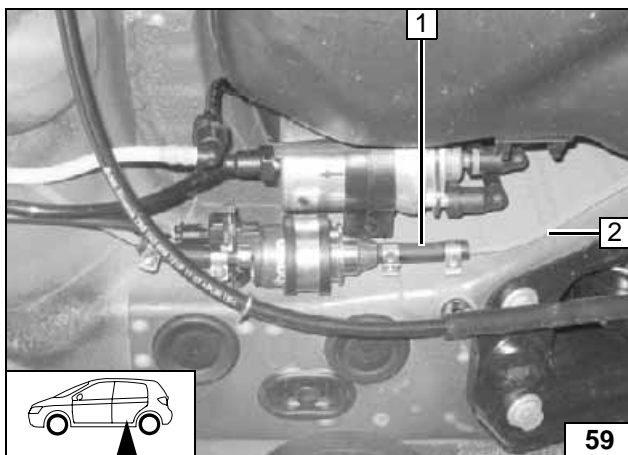

- 1** Hose section, 10 mm dia. hose clamp [2x]
- 2** Fuel line from fuel-tank sending unit



**Connecting intake side of metering pump**





**Coolant connection**

**WARNING!**

Tighten all hose clamps to 2.0 + 0.5 Nm.

Any coolant running off should be collected using an appropriate container!

Install hoses so that they are kink-free! Unless specified otherwise, always fasten using cable ties. Position hose clamps and spring band clamps so that no other hose can be damaged!

The connection should be "inline" based on the following diagram:

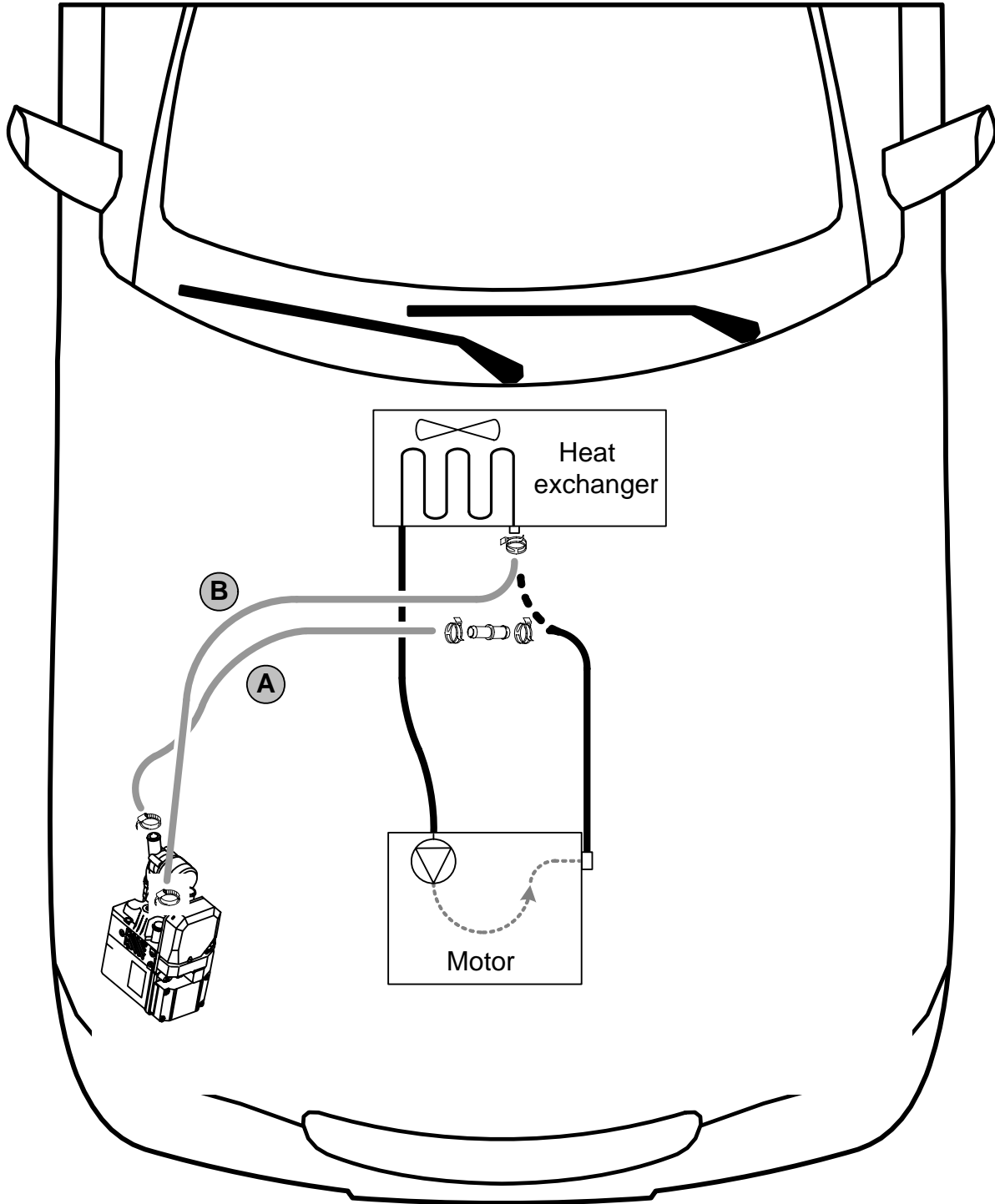

Coolant routing diagram

All hose clamps = 20-27 mm dia.! All spring clips = 27 mm dia.!  
Connecting pipe = dia. 20x20!



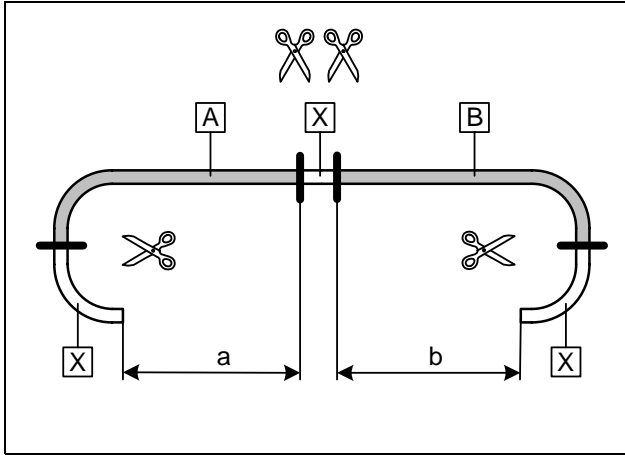

a = 900 mm  
b = 950 mm

Discard sections **X**

**Cutting coolant hoses to length**

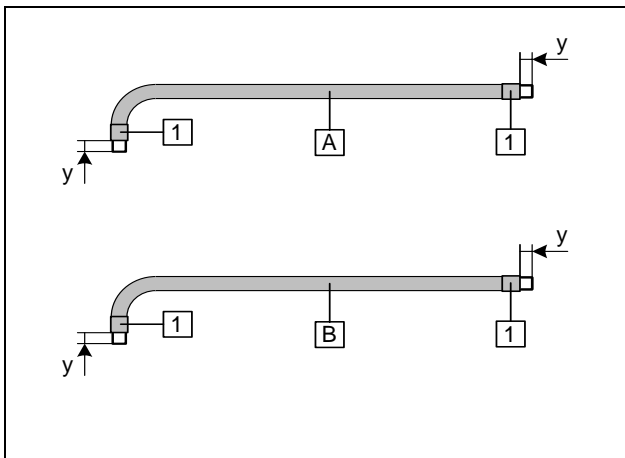

Push braided protection hoses onto hose **A** and **B**. Push on heat shrink plastic tubing and shrink.

y = 25 mm

**1** 50 mm heat shrink plastic tubing [4x]



**Preparing coolant hoses**

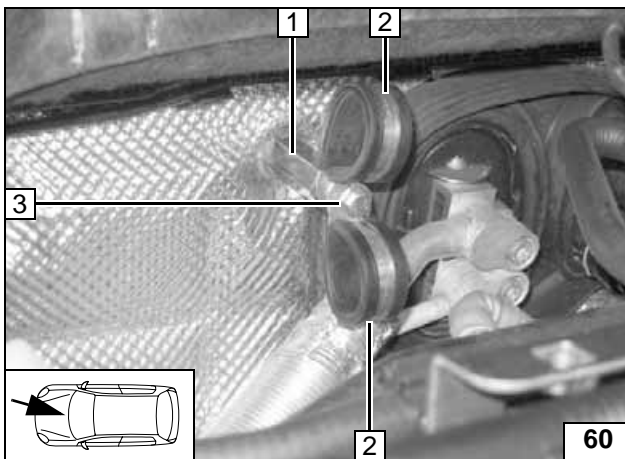

Pictures show 2.0FSI. Technical design of coolant connection is identical for 1.6MPI. Loosely mount bolt **3**.

- 1** Large diameter washer, 40 mm spacer nut, original vehicle stud bolt
- 2** 29 mm dia. rubber-coated p-clamp [2x]
- 3** M6x20 bolt, spring lockwasher



**Preassembling fastener**

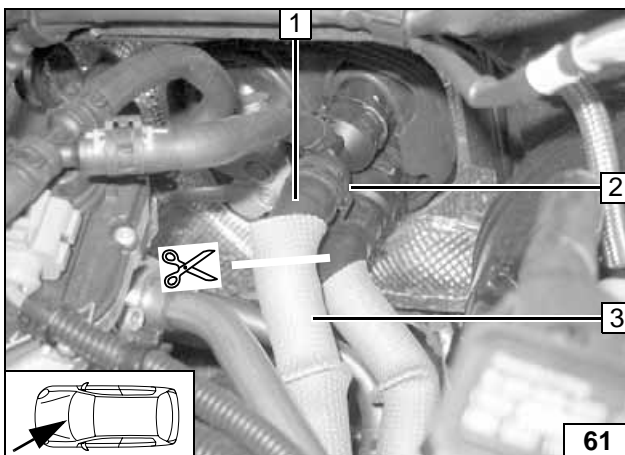

Pull off hose section **1** and discard. Spring clip **2** will be reused.

- 1** Hose to heat exchanger inlet
- 3** Hose from engine outlet

**Cutting point**



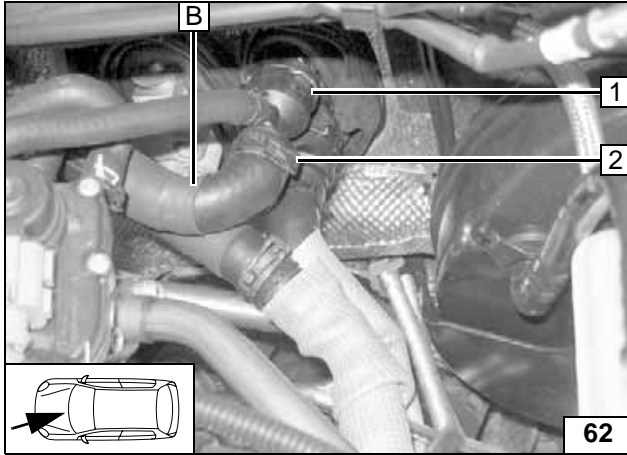

- 1 Heat exchanger inlet
- 2 Original vehicle spring clip

Conne-  
ction on  
heat ex-  
changer in-  
let

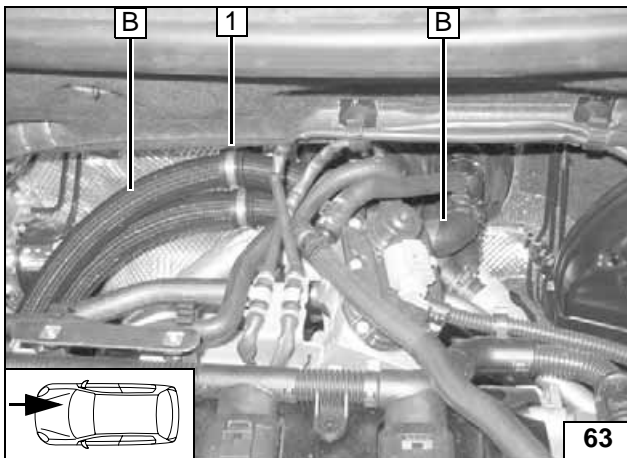

Route hose **B** through upper p-clamp.

- 1 Rubber-coated pipe clamp, 29 mm dia.



Hose rout-  
ing

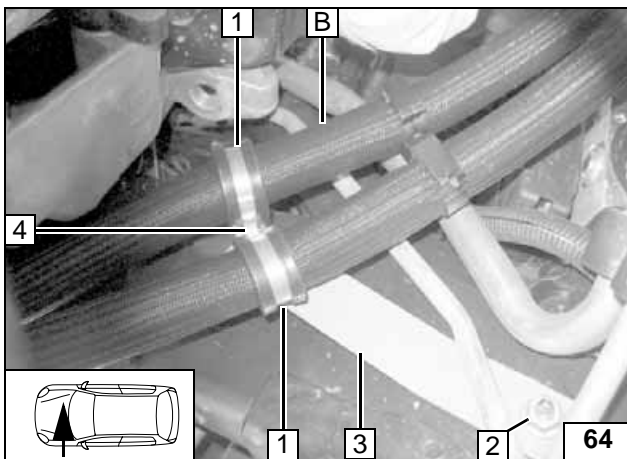

Ensure proper spacing between strut **3** and A/C line. Loosely mount bolt **4**. Route hose **B** through upper p-clamp.

- 1 29 mm dia. rubber-coated p-clamp [2x]
- 2 Original vehicle M8 nut
- 4 M6x20 bolt, flanged nut



Hose rout-  
ing

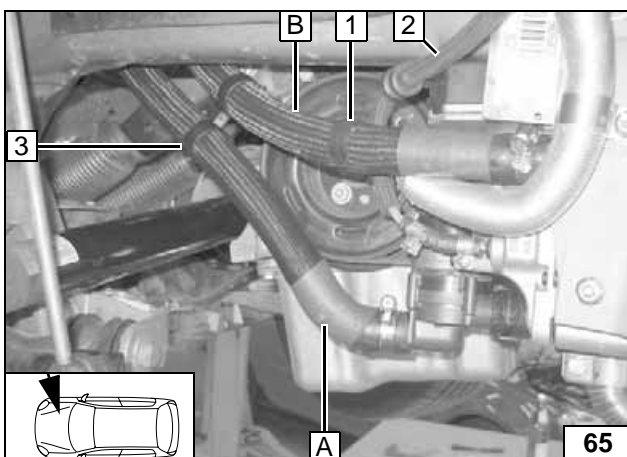

Fasten fuel line **2** on hose **B** with spacer **1**.

- 3 27x27 spacer, lockable



Conne-  
ction on  
heater unit

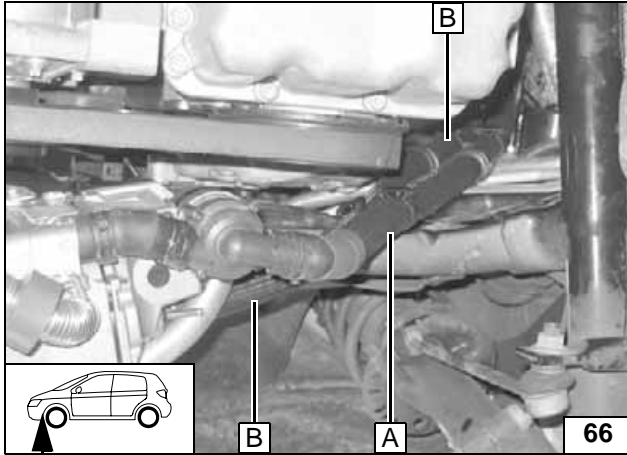

Hose routing

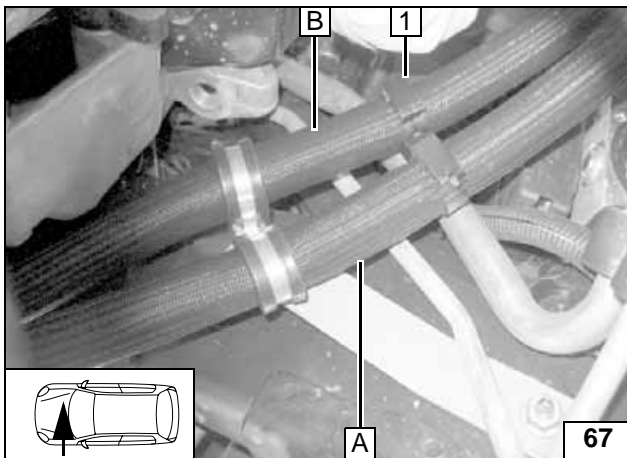

Route hose **A** through lower p-clamp.

1 27x27 spacer, lockable



Hose routing

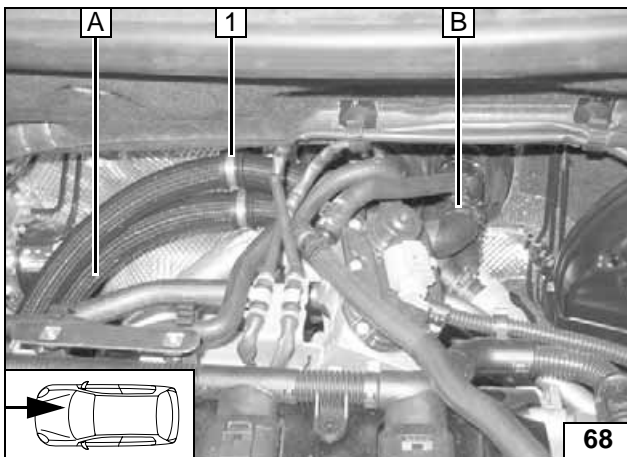

Route hose **A** through lower p-clamp.

1 Rubber-coated pipe clamp, 29 mm dia.



Hose routing

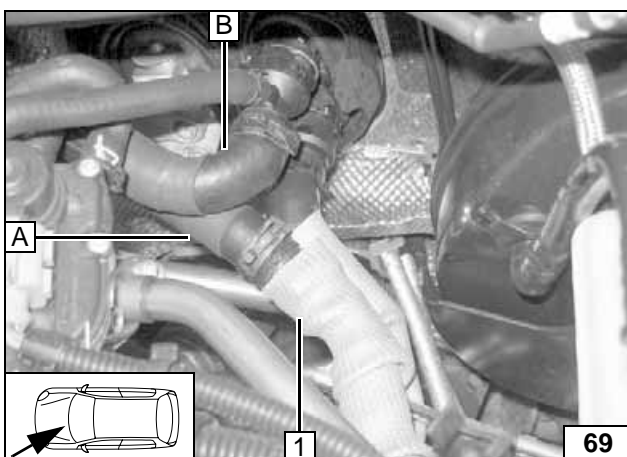

Before connecting, fill hoses with coolant. Check routing of hoses **A, B** along entire length and correct if necessary.

1 Hose of engine outlet



Connection to engine outlet



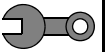

## Final Work

### WARNING!

Reassemble disassembled components in reverse order.

Check all hoses, spring and Caillau clamps, as well as all electrical connections for firm seating.

Only use manufacturer-approved coolant.

Secure all loose cables using cable ties.

Spray heater unit components with anti-corrosion wax (Tectyl 100K, Order No. 111 329).

- Connect battery
- Fill and bleed the coolant circuit according to the vehicle manufacturer's specifications.
- Set the digital timer.
- Adjust vehicle heater in accordance with "Operating Instructions for End Customer"
- Check the proper operation of the additional heater, see the operating instructions/installation instructions.
- File included vehicle-specific "Operating Instructions for End Customer" in vehicle logbook
- Attach the "Switch off additional heater before refueling" sticker to the left-hand B-pillar.

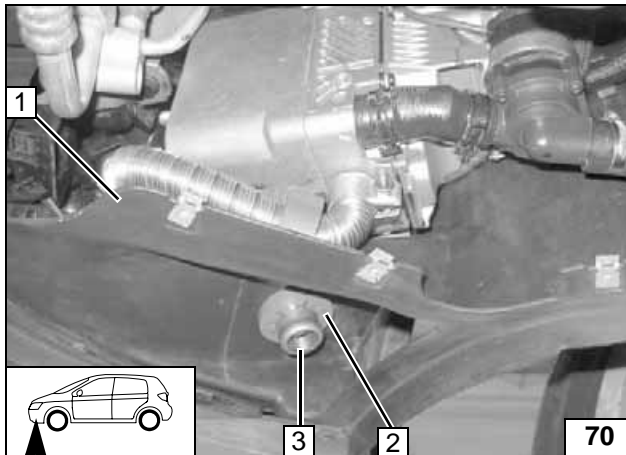

Drill 42 mm hole directly below exhaust end section **3** in wheel well trim **1**. Insert red (rt) rubber profile with groove **2** in hole. Ensure sufficient spacing of exhaust system to other components. Correct position if necessary.

**Exhaust-gas pass through**



# Webasto

*Feel the drive*

Webasto AG  
Postfach 80 - 82132 Stockdorf, Germany - Hotline +49-(0)1805-932278  
Hotfax +49-(0)395-5592-353 - <http://www.webasto.de>

## Operating Instructions for End Customer

Please remove page and add to the vehicle operating instructions.



**Note:**

We recommend matching the heating time to the driving time.

Heating time = driving time

**Example:**

For a driving time of approx. 20 min. (in one direction), we recommend not exceeding a switch-on time of 20 min.

If the summer/winter switch option has been installed, this must be switched in accordance with the time of year. The heater unit will then only switch on the vehicle fan to ventilate the vehicle interior in the position Winter  heat and in the position Summer .

Before parking the vehicle, make the following settings:

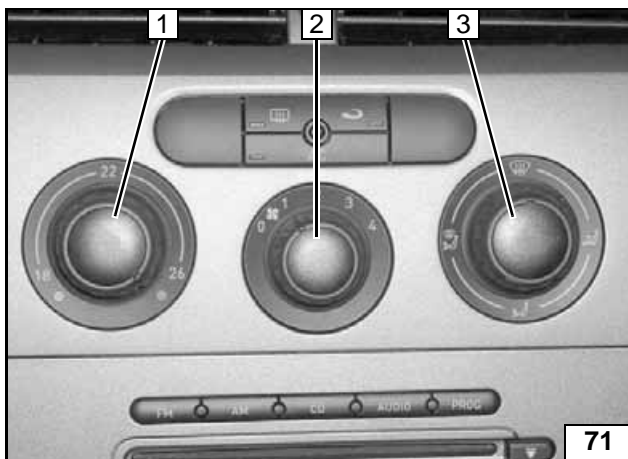

- 1 Set temperature to "max."
- 2 Set fan to level "1", or possibly "2"
- 3 Direct air outlet toward windshield

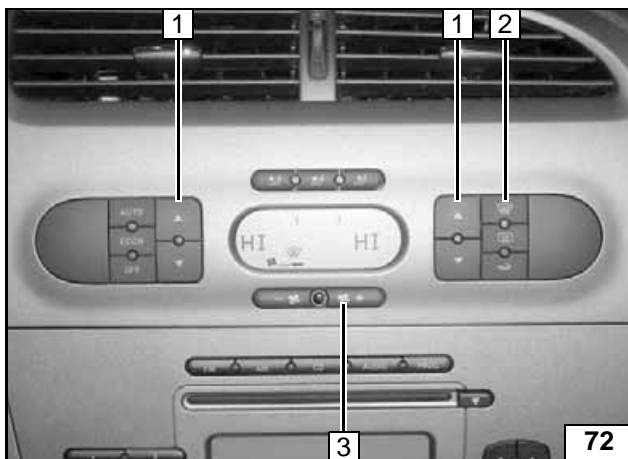

- 1 Set temperature on both sides to "high"
- 2 Air outlet to windshield
- 3 Set fan to level "1", or possibly "2"

Vehicles  
without  
Climatronic

Vehicle  
with Climatronic