

# Water Heater Unit



**Thermo Top E Additional Heater** e1 00 0003

**Thermo Top C Additional Heater** e1 00 0002

**Thermo Top P Additional Heater** e1 00 0104

## Installation Instructions

### Dacia Logan / Dacia Sandero

Special

Gasoline

from Model Year 2006

Left-hand drive vehicle



#### **WARNING!**

Hazard warning:

Incorrect installation or repair of Webasto heating systems may cause a fire or result in the emission of carbon monoxide, which can be fatal. Serious or fatal injuries can be caused as a result.

Specialist company training, technical documentation, specialized tools and equipment are required to install and repair Webasto heating and cooling systems.

NEVER attempt to install or repair Webasto heating or cooling systems if you have not successfully completed the company training and thereby acquired the required technical skills, or if you do not have access to the required technical documentation, tools and equipment needed to carry out correct installation and repairs.

ALWAYS follow all Webasto installation and repair instructions and observe all warnings.

Webasto does not accept any liability for defects and damage that are attributable to installation by untrained staff.

## Table of Contents

Validity	2	Preparing heater unit	10
Heater Unit/Installation Kit	3	Preparing installation location	10
Foreword	3	Installing heater unit	12
General Instructions	3	Coolant connection on 1.4l MPI and 1.6l MPI	13
Special Tools	3	Coolant connection on 1.6 l 16 V	17
Explanatory Notes on Document	4	Combustion air	21
Preliminary Work	5	Fuel	22
Heater unit installation location	5	Exhaust gas	25
Electrical system of Dacia Logan	6	Final Work	27
Electrical system of Dacia Sandero	7	Template for Fuel Standpipe	28
Fan controller	8	Operating Instructions for End Customer	29
Remote option (Telestart)	9		

## Validity

Manufacturer	Model	Type	EG-BE No./ABE
Dacia	Logan	SD	e2 * 2001/116 * 0314
Dacia	Sandero	SD	e2 * 2001/116 * 0314

Engine type	Engine model	Output in kW	Displacement in cm <sup>3</sup>
K7J	Gasoline	55	1390
K7M	Gasoline	64	1598
K4M	Gasoline	77	1598

Vehicle and engine types, equipment variants and national specifications not listed in these installation instructions have not been tested. However, installation according to these installation instructions may be possible.

The installation location of a digital timer and summer/winter switch should be confirmed with the end customer before installation.

## Heater Unit/Installation Kit

Quantity	Description	Order No.:
1	Renault-specific heater unit delivery scope	See Renault price list
1	Installation kit for special Dacia Logan / Dacia Sandero Gasoline	1312497B

### Heater unit recommended for the respective vehicle class:

Vehicle	Heater Unit
Compact car	Thermo Top E
Mid-size car, station wagon	Thermo Top C
Full-size car, van, offroader	Thermo Top P

The selection of the heater unit is based on the passenger compartment size of the vehicle and the level of comfort required by the customer!



## Foreword

These installation instructions apply to Dacia Logan / Dacia Sandero Gasoline vehicles - for validity, see page 2 - from model year 2006 and later, assuming technical modifications to the vehicle do not affect installation, any liability claims excluded. Depending on the vehicle version and equipment, modifications may be necessary during installation with respect to these installation instructions.

However, the stipulations in the "installation instructions" and "operating and maintenance instructions" for the *Thermo Top C/P/E* must always be observed.

The corresponding rules of technology and any information from the vehicle manufacturer should be observed during the installation work.

## General Instructions

Installation should be carried out according to the general, standard rules of technology. Unless specified otherwise, fasten hoses, lines and wiring harnesses to original vehicle lines and wiring harnesses using cable ties.

Sharp edges should be fitted with edge protectors (split-open plastic hose).

Spray unfinished body areas, e.g. drilled holes, with anti-corrosion wax (Tectyl 100K, Order No. 111329).

## Special Tools

- Torque wrench for 2.0 - 10 Nm
- Hose clamping pliers
- Metric thread-setter kit

**Explanatory Notes on Document**

To provide you with a quick overview of the individual working steps, you will find an identification mark on the outside top right corner of the page in question.

**Mechanical system**

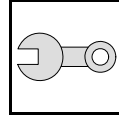

**Electrical system**

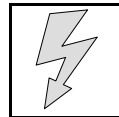

**Coolant**

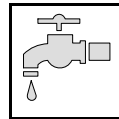

**Fuel**

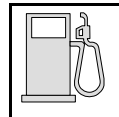

**Exhaust gas**

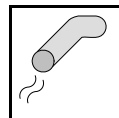

**Combustion air**

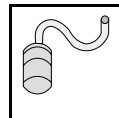

**Special features are highlighted using the following symbols:**



Specific risk of injury or fatal accidents.



Specific risk of damage to components.



Specific risk of fire or explosion.



Reference to general installation instructions of Webasto components or to the manufacturer's vehicle-specific documents.



Reference to a special technical feature.



The arrow in the vehicle icon indicates the position on the vehicle and the viewing angle.

**All dimensions are in mm!**

**Tightening torque of hose clamps = 2.0 + 0.5 Nm!**

**Tightening torque of Ejet screws, Ejet studs = 10 Nm!**

**Preliminary Work**

**WARNING!**

- Open fuel tank cap, ventilate tank.
- Close the tank cap again.
- Disconnect the battery "earth" or "ground" connection.
- Depressurize the cooling system!
- Copy the factory number from the original type label to the duplicate type label.
- Remove years that do not apply from the duplicate label.
- Attach the duplicate label (type label) in the appropriate place.
- Remove the air filter complete with the intake hose (only on 1.6 l 16V)
- Remove the left-hand wheel well trim.
- Remove the bumper.
- Remove the underride protection on the left.
- Open the right-hand fuel sender service lid.
- Remove the fuel-tank sending unit in accordance with the manufacturers specifications.
- Remove the fan controls

Remove page 29 "Operating Instructions for End Customer" and add to the vehicle operating instructions.

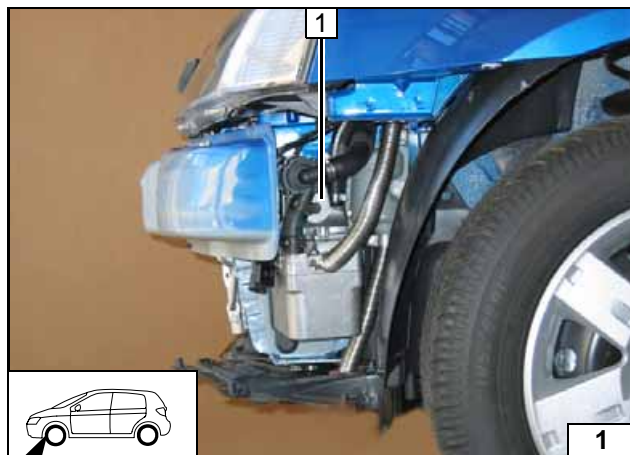

**Heater unit installation location**

- 1 Heater unit

**Installation location**



**Electrical system of Dacia Logan**

**Fuse holder, K3 relay**

- 1 K3 relay, 5.5x9.5 self-tapping screw
- 2 Retaining plate of fuse holder, 5.5x9.5 self-tapping screw
- 3 Fuse holder

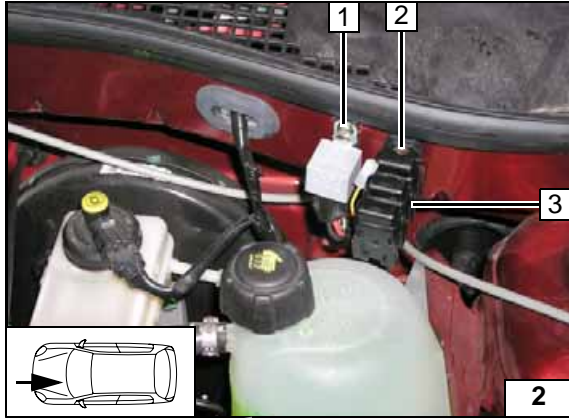

**Digital timer**

- 1 Digital timer

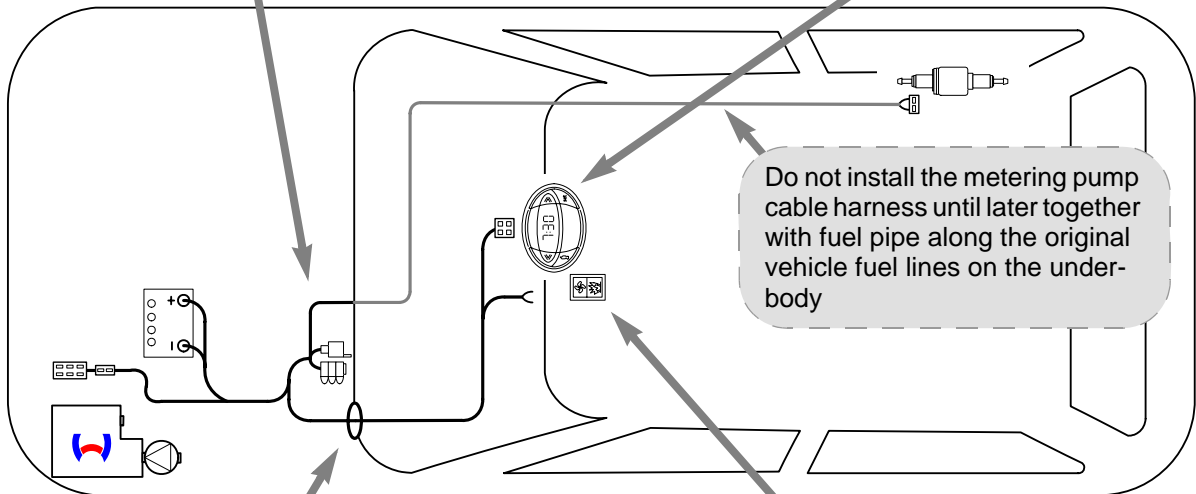

**Wiring harness installation diagram**

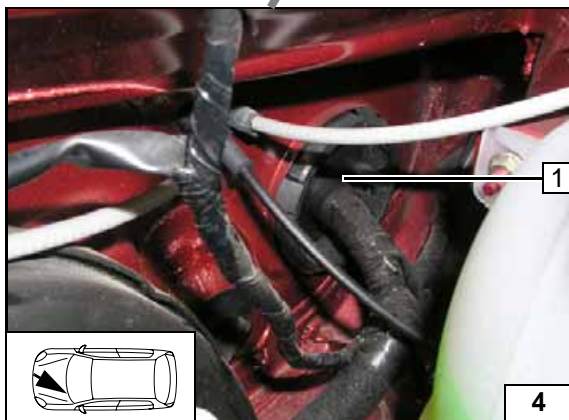

**Wiring harness pass through**

- 1 Protective rubber plug



**Summer/winter switch option**

- 1 Summer/winter switch



**Electrical system of Dacia Sandero**

**Fuse holder, K3 relay**

- 1 K3 relay, 5.5x9.5 self-tapping screw
- 2 Retaining plate of fuse holder, 5.5x9.5 self-tapping screw
- 3 Fuse holder

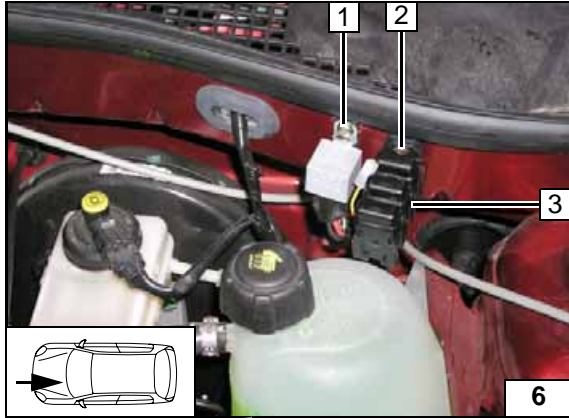

**Digital timer**

- 1 Digital timer

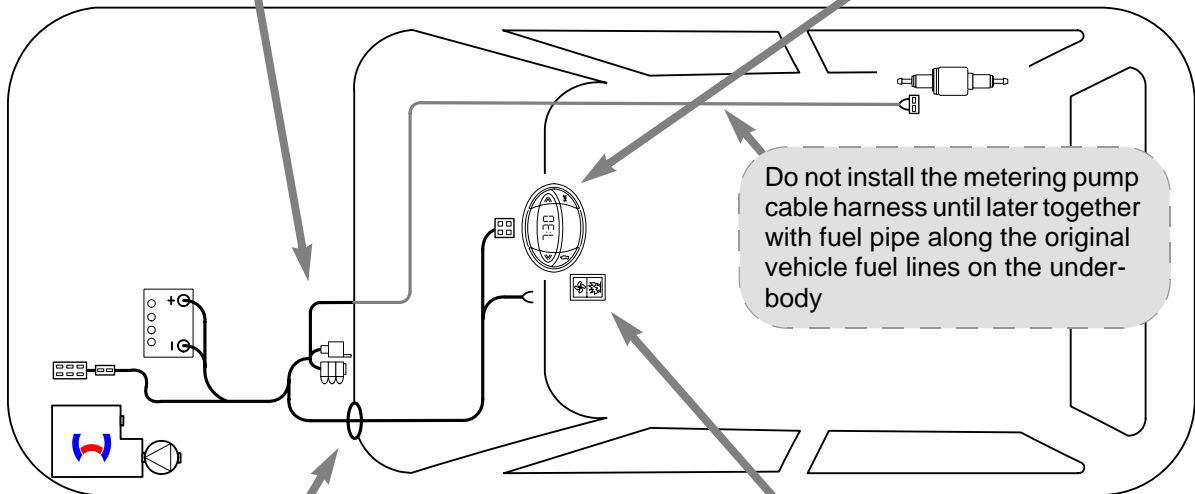

**Wiring harness installation diagram**

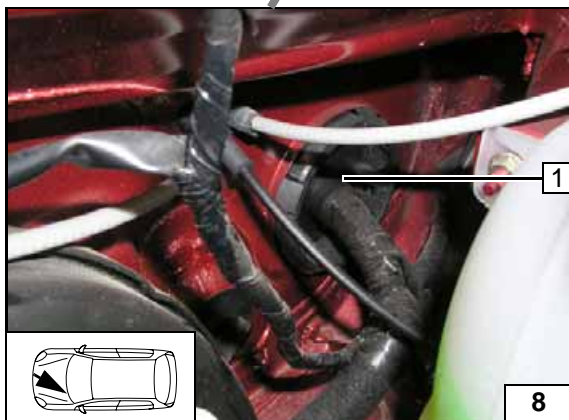

**Wiring harness pass through**

- 1 Protective rubber plug



**Summer/winter switch option**

- 1 Summer/winter switch



Fan controller

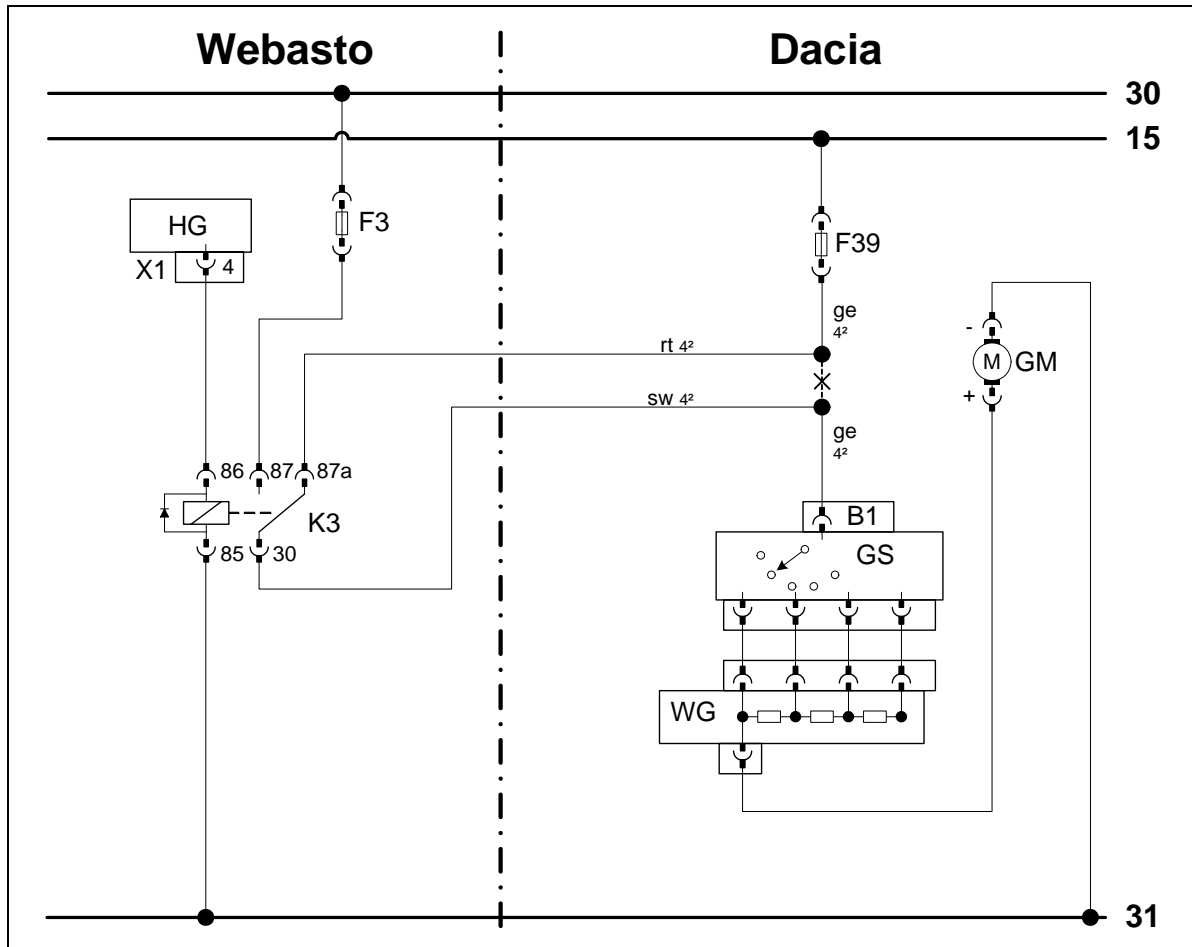

Wiring diagram

Webasto components		Vehicle components		Colors and symbols	
HG	Heater unit TT-C/E	GM	Fan motor	rt	red
X1	6-pin heater unit connector	GS	Fan switch	ge	yellow
F3	25 A fuse	WG	Resistor group	sw	black
K3	Fan relay	B1	Connector B Pin 1		
		F39	Fuse 30A	X	Cutting point
				Wiring colors may vary.	

Legend

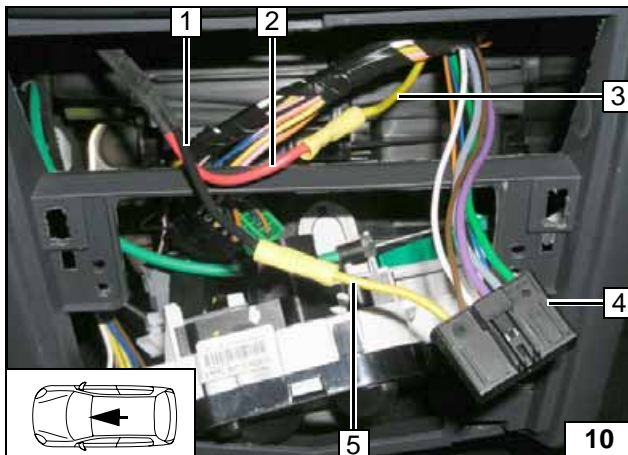

Connection to 6-pin connector B 4 from fan switch.  
Produce connections as shown in wiring diagram.

- 1 Black (sw) wire from K3/30
- 2 Red (rt) wire from K3/87a
- 3 Yellow (ge) wire from fuse 39
- 5 Yellow (ge) wire from connector B1



Connecting fan-motor





**Remote option (Telestart)**

- 1 Telestart bracket
- 2 Telestart
- 3 Original vehicle bolt



**Installing receiver**

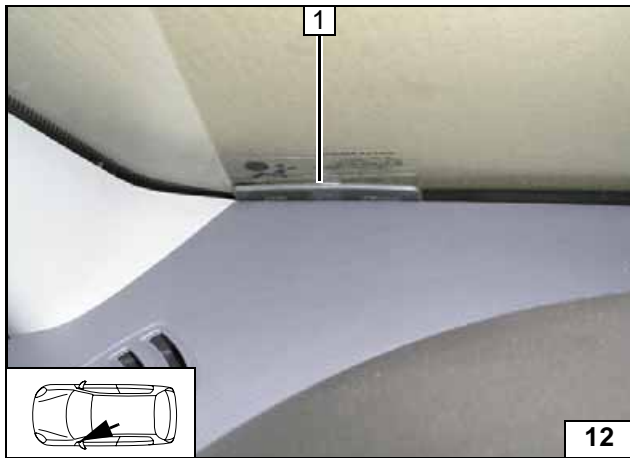

- 1 Antenna

**Installing antenna**

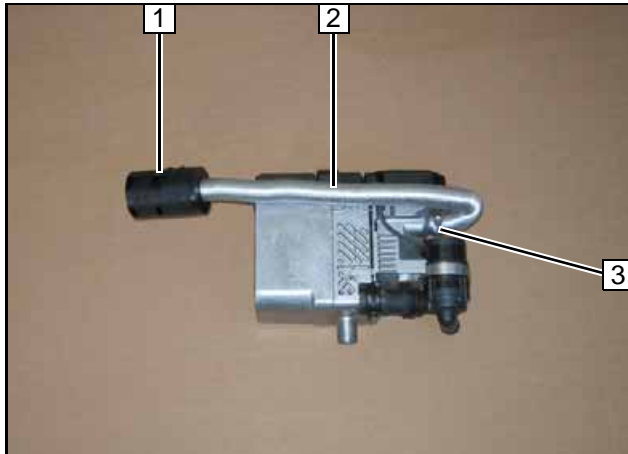
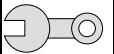

**Preparing heater unit**

- 1 Combustion-air intake muffler
- 2 Combustion-air intake pipe
- 3 27 mm dia. clamp

Premounting combustion air

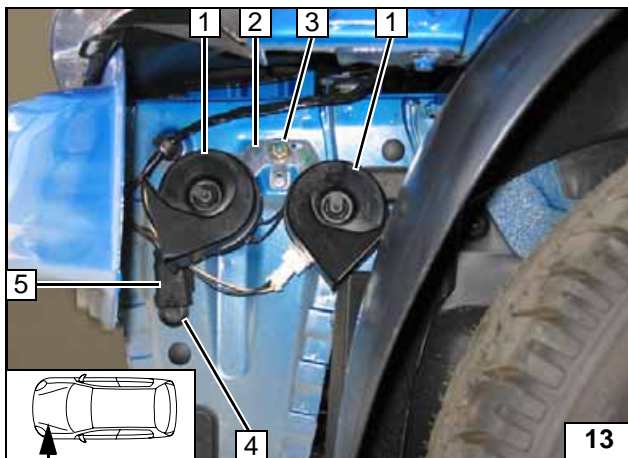

**Preparing installation location**

**Note:**  
The horns need not be converted on the Dacia Sandero!

Remove horns 1 [2x]; M6 flanged nut will be reused!  
Discard horn bracket 2 and original vehicle nut 3.

- 4 Discard plug
- 5 Unclip connector



Removing horns

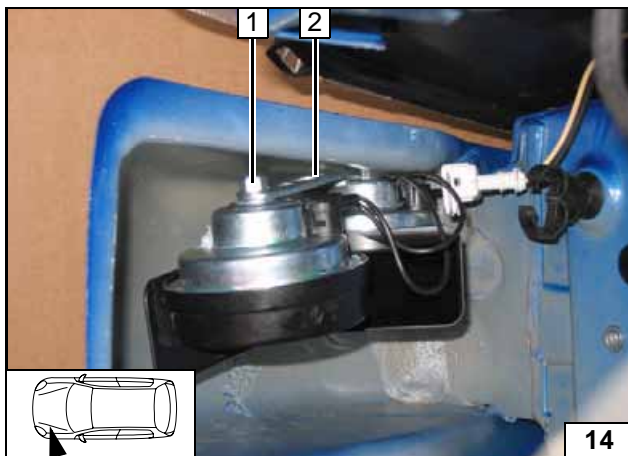

- 1 Original vehicle M6 flanged nut
- 2 Perforated bracket

Installing horns

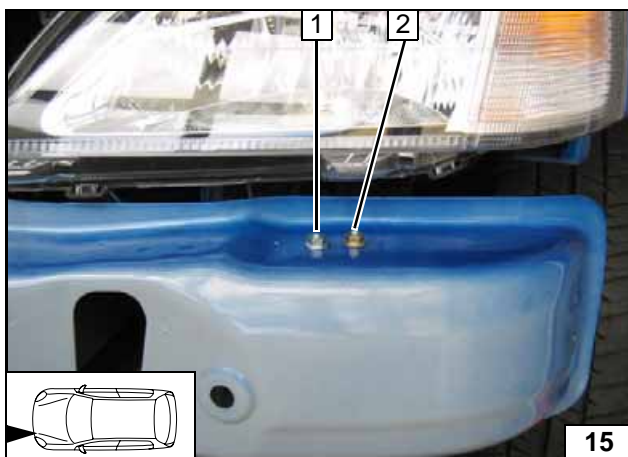

- 1 Horn, original vehicle hole, original vehicle flanged nut M6
- 2 M6x12 bolt, perforated bracket, original vehicle hole, flanged nut

Installing horns

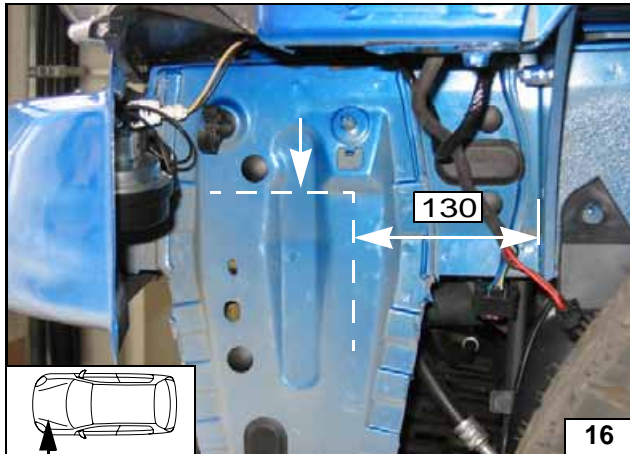
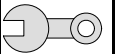

Lay on bracket at lower edge of bead (see marking).



Laying on bracket

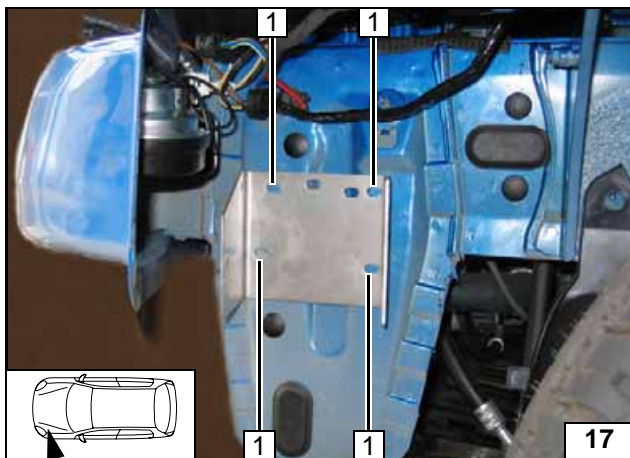

Copy hole pattern 1 [4x].



Copying hole pattern

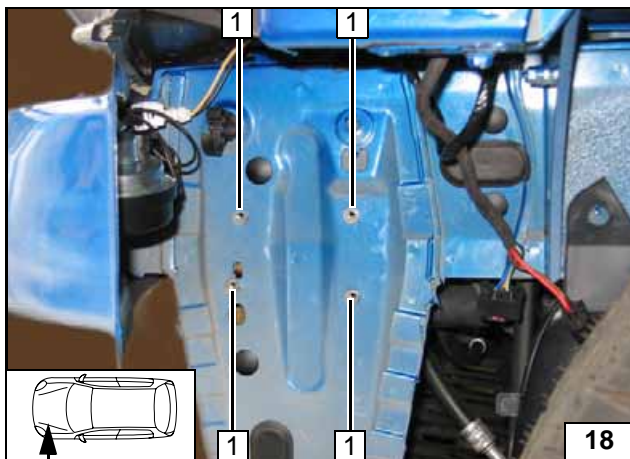

Drill 9 mm dia. holes [4x] and mount rivet nuts 1 [4x].



Installing rivet nut

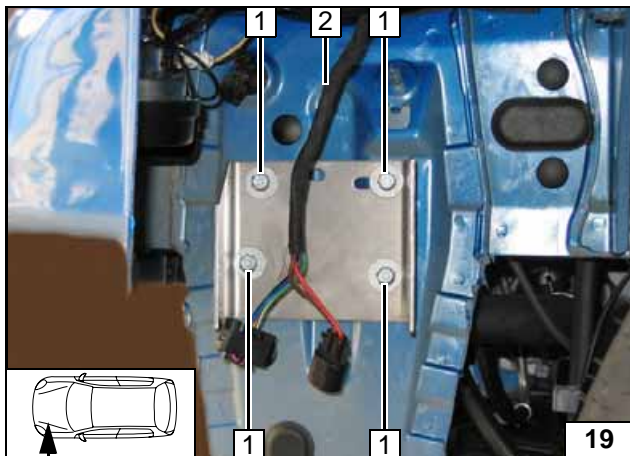

- 1 M6x20 bolt, spring lockwasher, flanged nut [4x each]
- 2 Wiring harness of heater unit

Installing bracket

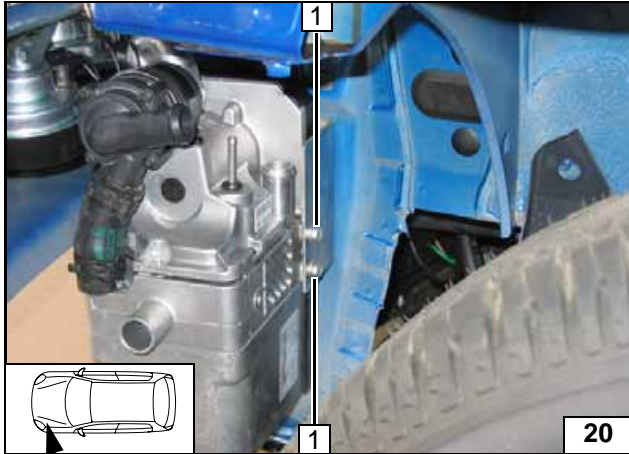
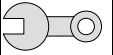

**Installing heater unit**

Connect wiring harness before installing heater unit.

1 Eject screw [2x]



**Installing heater unit**

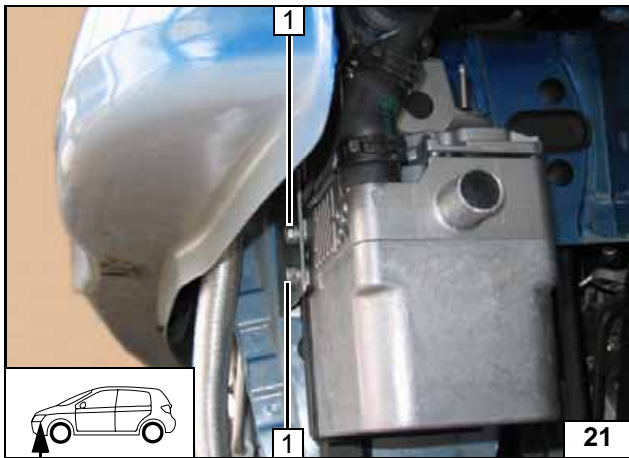

1 Eject screw [2x]

**Installing heater unit**



**Coolant connection on 1.4l MPI and 1.6l MPI**

**WARNING!**

Any coolant running off should be collected using an appropriate container. Install coolant hoses kink-free. Unless specified otherwise, always fasten using cable ties. Position clamps so that no other hose can be damaged! When installing the coolant hose, the heater unit must be filled with coolant. The connection should be "inline" based on the following diagram:

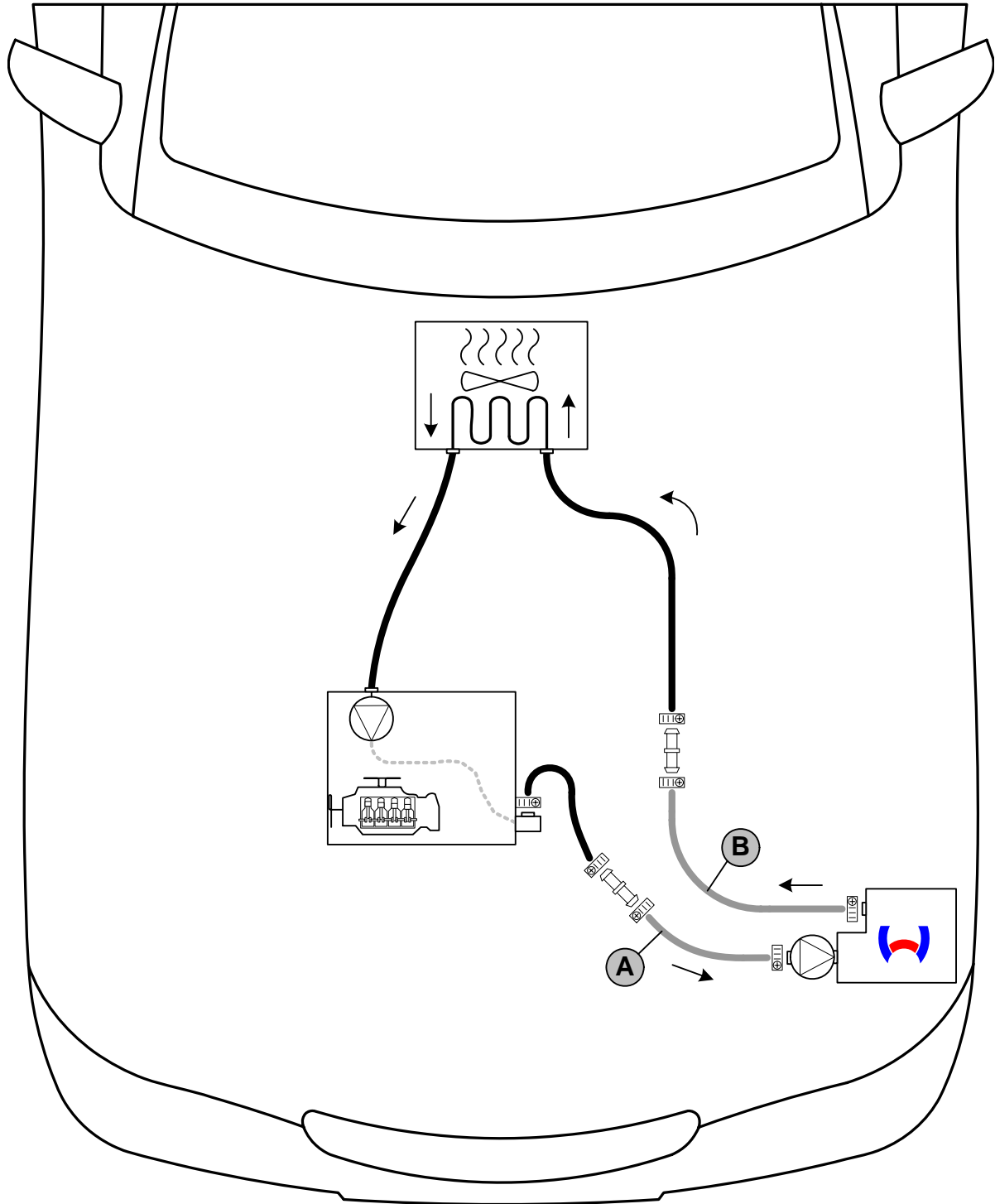

Coolant routing diagram

All connecting pipes  = 18x20 mm dia.

All hose clamps without a specific designation  = 20-27 mm dia.



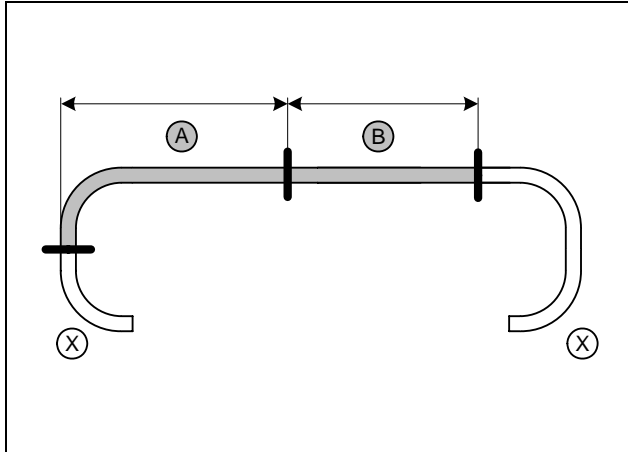

a = 580  
b = 830

Discard section X

**Cutting coolant hoses to length**

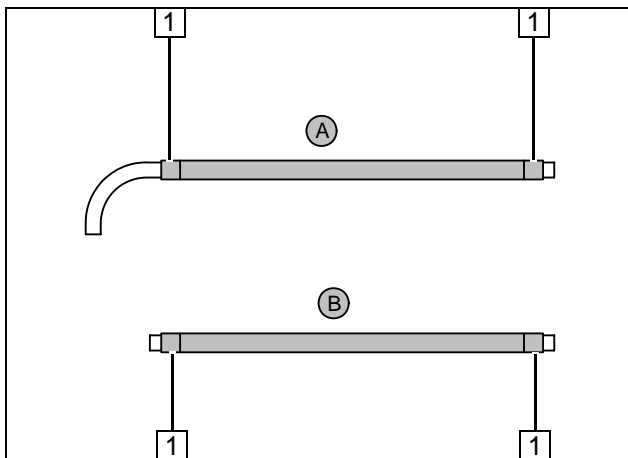

Push braided protection hoses onto hose A and B and cut to length.  
Cut heat shrink plastic tubing to length.

1 25 mm long heat shrink plastic tubing [4x]

**Preparing coolant hoses**

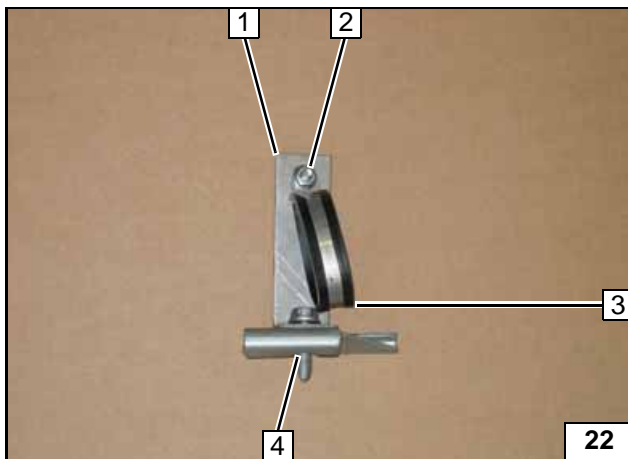

Remove battery mount 4.

- 1 Angle bracket
- 2 M6x20 bolt, flanged nut
- 3 Loosely install 48 mm dia. rubber-coated p-clamp

**Preparing hose bracket**

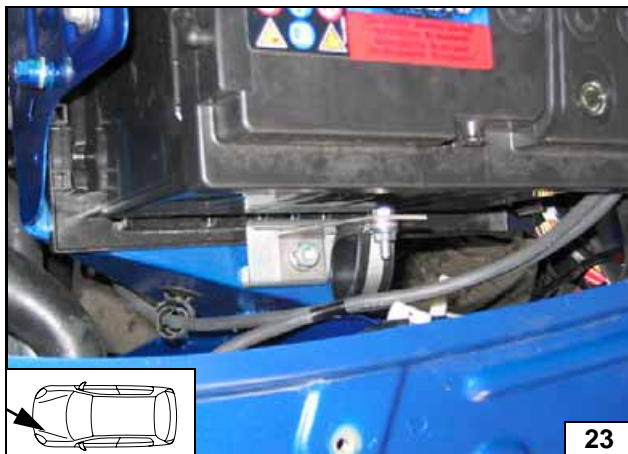

**Installing hose bracket**

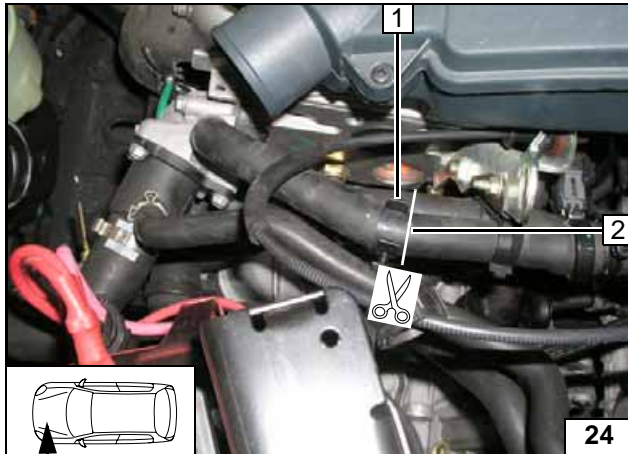

Remove hose bracket 1 before separating. This will be reused later!

2 Cutting point



Cutting point

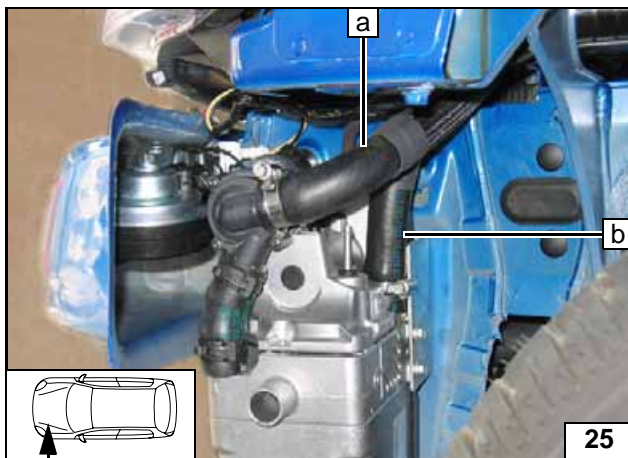

Connect-  
ing heater  
unit

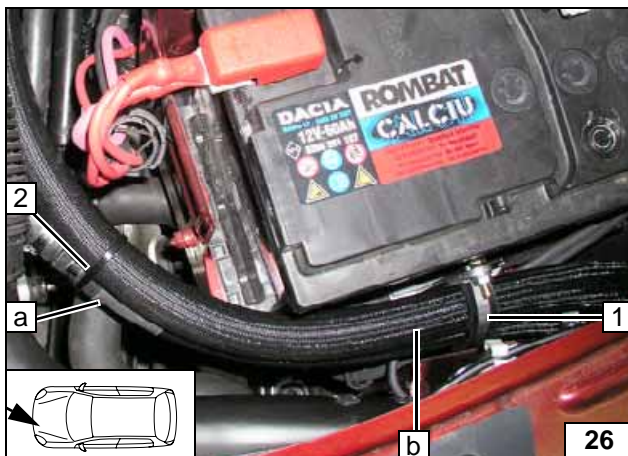

Push hose A and B through hose bracket 1 when installing. Then tighten screw connection.

2 Cable tie



Routing in  
engine  
compart-  
ment

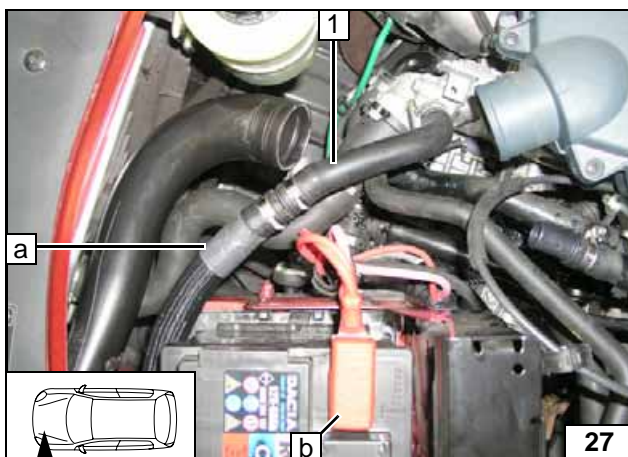

1 Hose on engine outlet turned

Connect-  
ing engine  
outlet

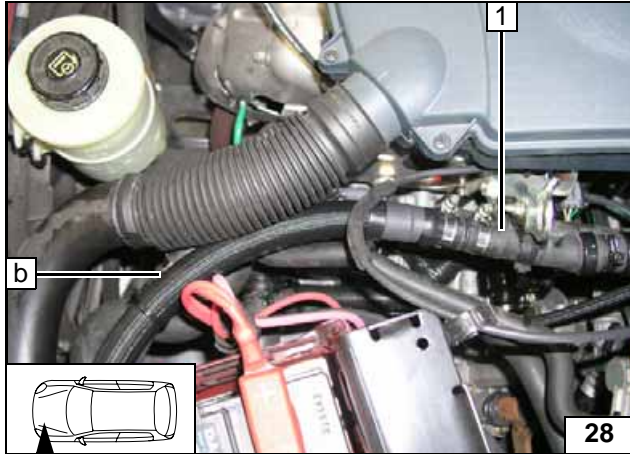

Ensure sufficient distance to neighboring components.

1 Hose on heat exchanger inlet



Connect-  
ing heat  
exchanger  
inlet







**Coolant connection on 1.6 I 16 V**

**WARNING!**

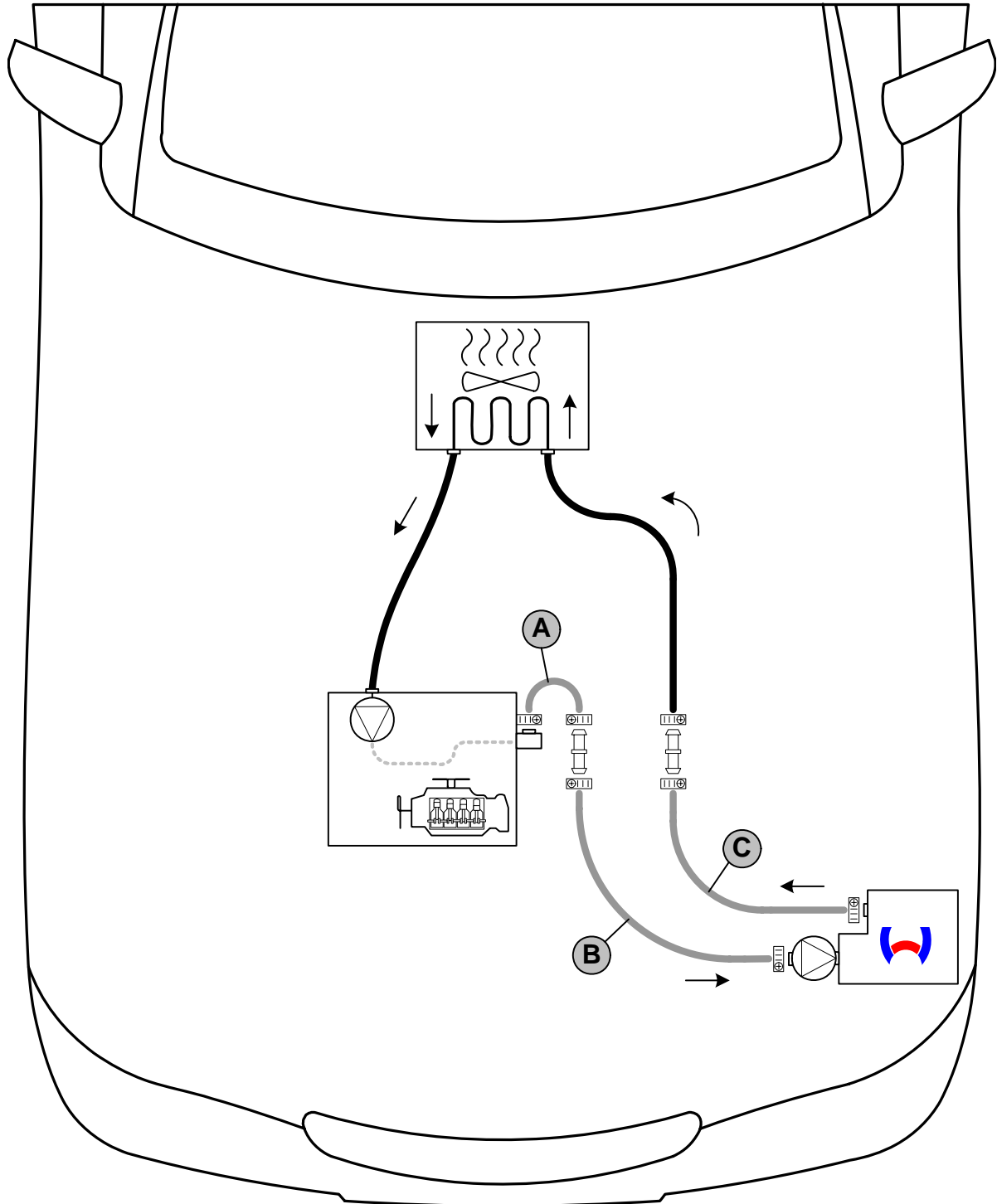
Any coolant running off should be collected using an appropriate container. Install coolant hoses kink-free. Unless specified otherwise, always fasten using cable ties. Position clamps so that no other hose can be damaged! When installing the coolant hose, the heater unit must be filled with coolant. The connection should be "inline" based on the following diagram:



**Coolant routing diagram**

All connecting pipes  = 18x20 mm dia.

All hose clamps without a specific designation  = 20-27 mm dia.



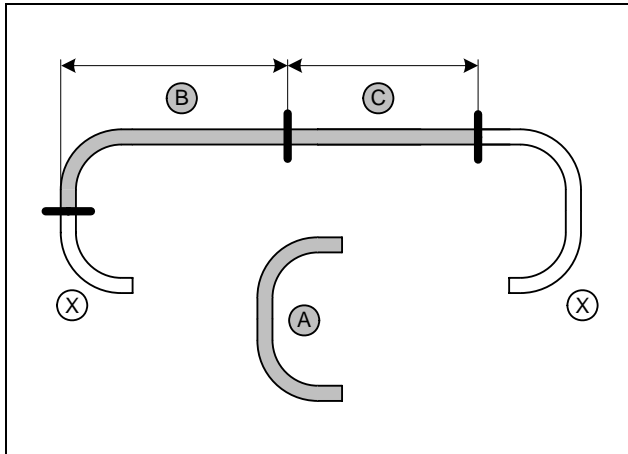

b = 780  
c = 780

Discard section X

**Cutting coolant hoses to length**

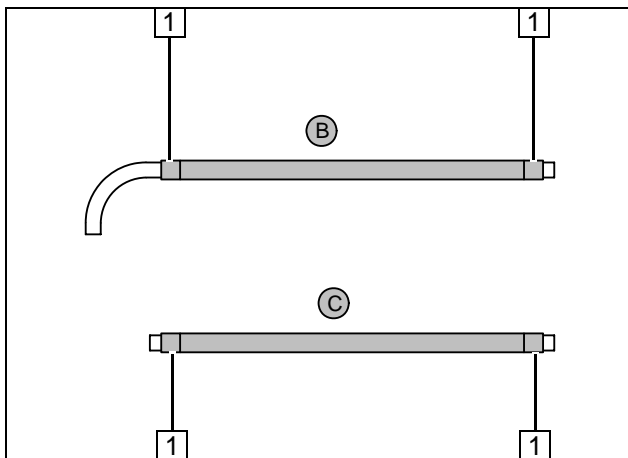

Push braided protection hoses onto hose **B** and **C** and cut to length.  
Cut heat shrink plastic tubing to length.

**1** 25 mm long heat shrink plastic tubing [4x]



**Preparing coolant hoses**

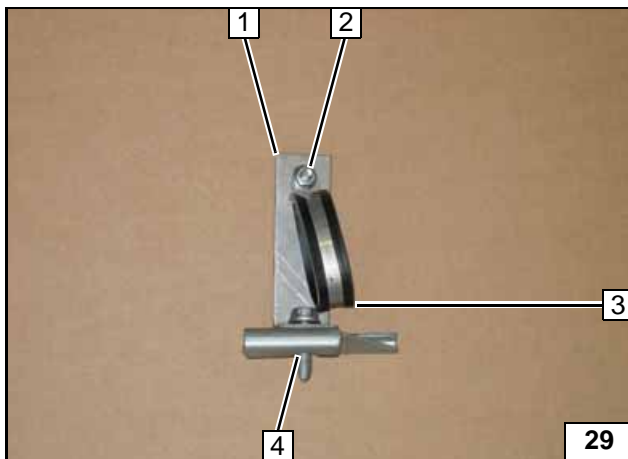

Remove battery mount **4**.

- 1** Angle bracket
- 2** M6x20 bolt, flanged nut
- 3** Loosely install 48 mm dia. rubber-coated p-clamp



**Preparing hose bracket**

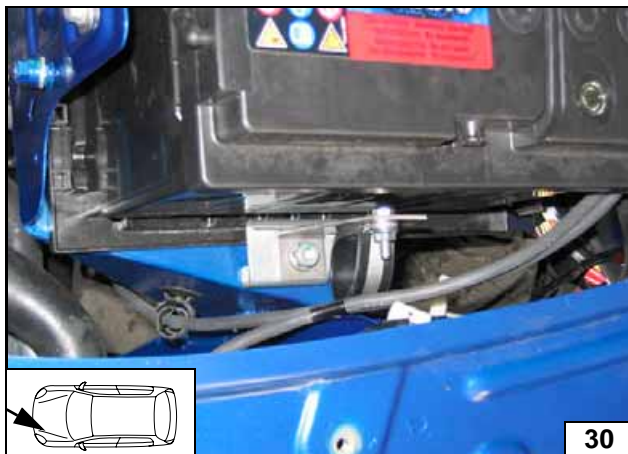

**Installing hose bracket**

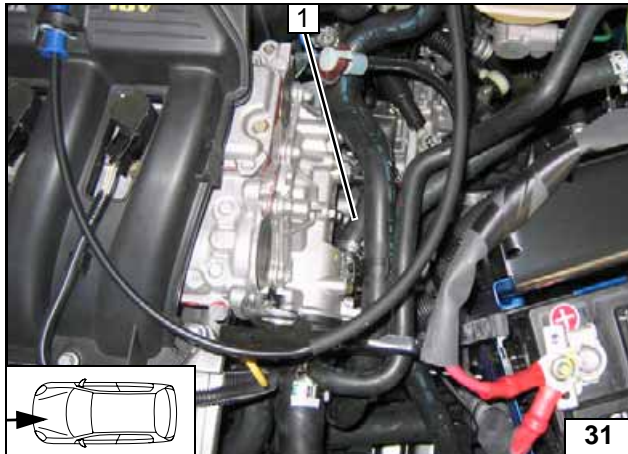

Pull hose of heat exchanger inlet **1** off engine outlet. Discard original vehicle clamp.



Cutting point

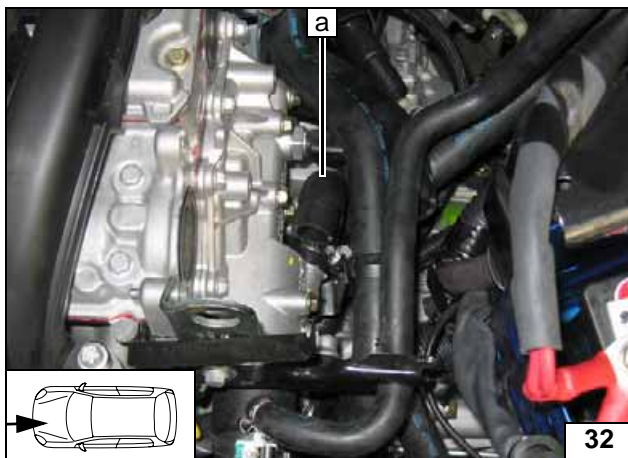

Connecting hose **A** on engine outlet

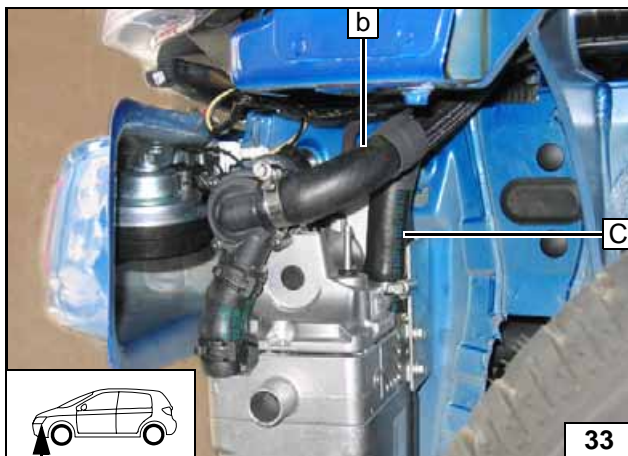

Connection to heater unit

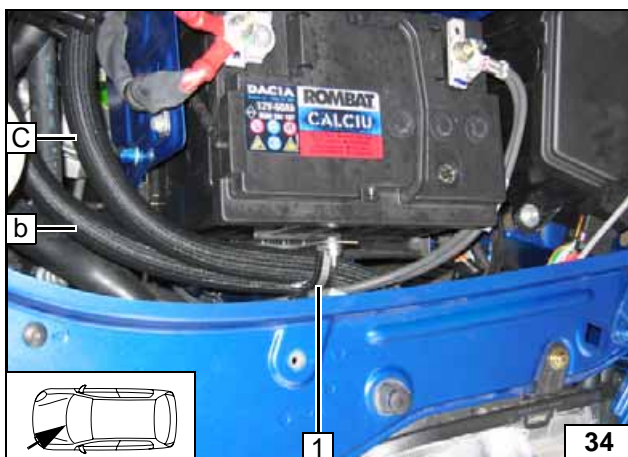

Push hose **B** and **C** through hose bracket **1** when installing. Then tighten screw connection.



Routing in engine compartment

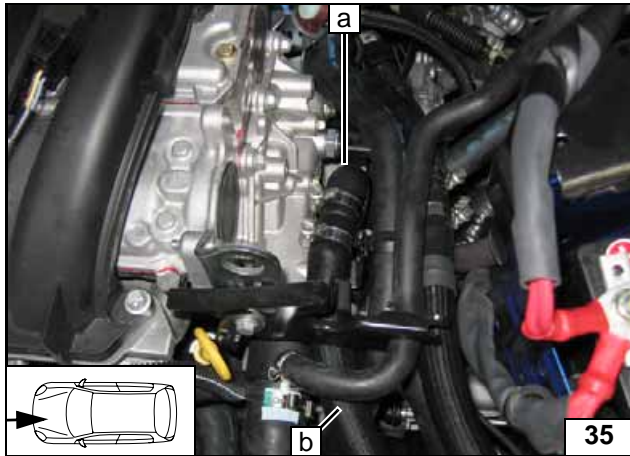

Con-  
nec-  
tion to  
hose A

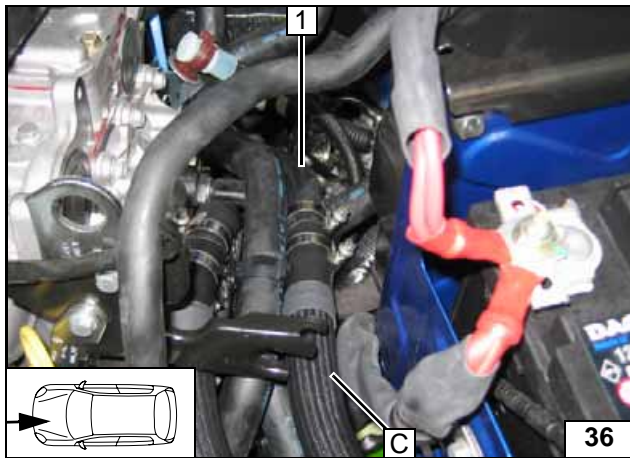

Ensure sufficient distance to neighboring components.

1 Hose on heat exchanger inlet



Con-  
nec-  
tion on  
heat ex-  
changer in-  
let

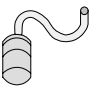

**Combustion air**

- 1 Cable tie [4x]



**Fastening  
muffler**

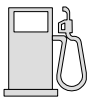

**Fuel**

**CAUTION!**

Open the vehicle's fuel tank cap, ventilate the tank and then re-close the tank lock.

Catch any fuel running off with an appropriate container.

Install fuel line and metering-pump wiring harness so that they are protected against stone impact. Unless specified otherwise, always fasten using cable ties. Mount the fuel line and wiring harness with rub protection on sharp edges.

**WARNING!**

The fuel line and wiring harness are routed to the metering pump in as shown in the wiring harness routing diagram.

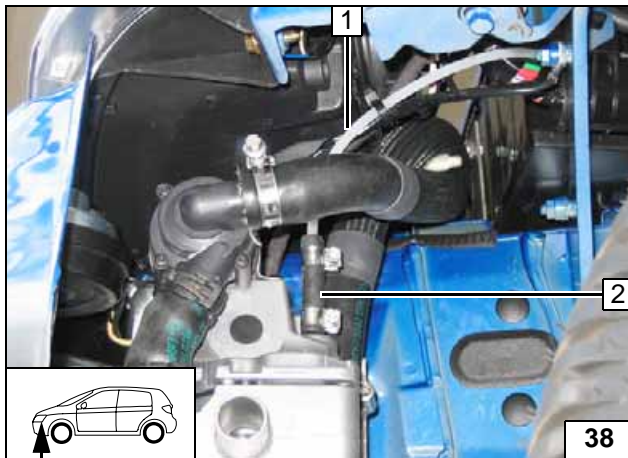

- 1 Fuel line
- 2 Hose section, 10 mm dia. clamp [2x]

**Conne-  
ction to  
heater unit**

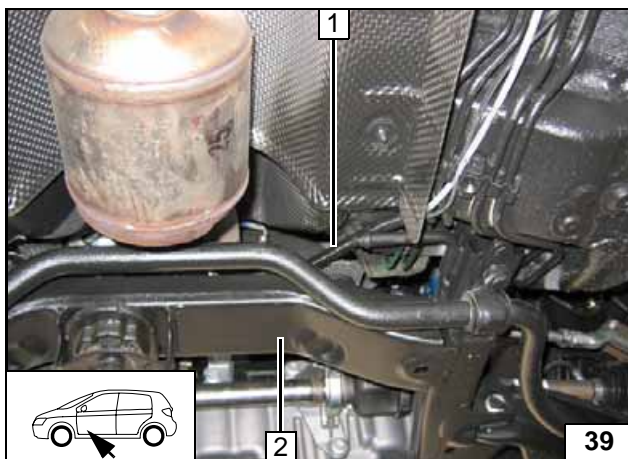

Install fuel line with wiring harness of metering pump in corrugated tube **1**, route to underbody and over **cross member 2** to right-hand side of vehicle.



**Installing  
lines**

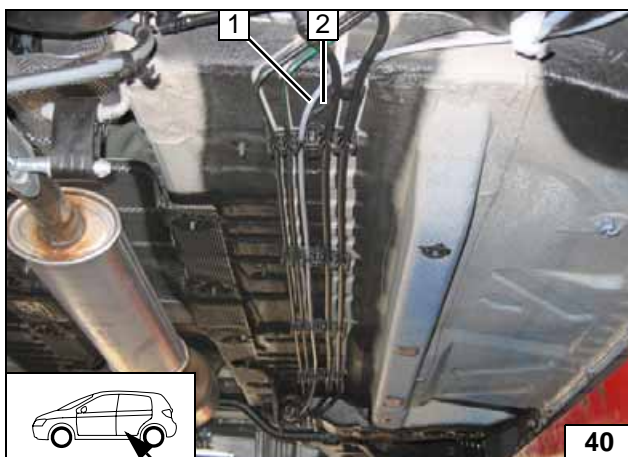

- 1 Fuel line from heater unit
- 2 Metering pump wiring harness

**Routing on  
underbody**

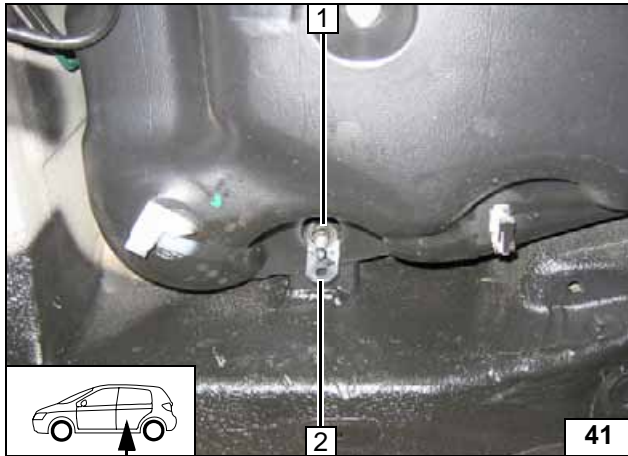
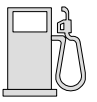

- 1 Original vehicle stud bolt with nut
- 2 Angle bracket

**Installing metering pump**

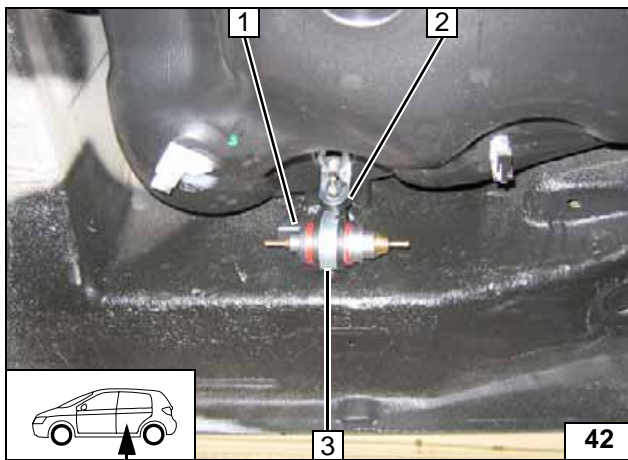

- 1 Metering pump
- 2 Silent block, flanged nut [2x]
- 3 Rubber-coated pipe clamp

**Installing metering pump**

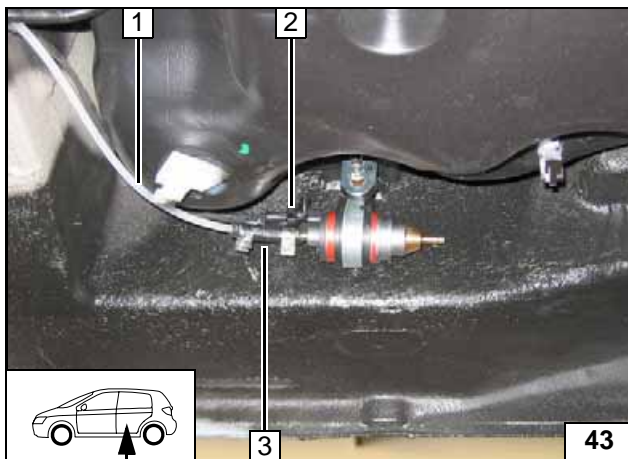

Check the position of the components; adjust if necessary. Check that they have free clearance.

- 1 Fuel line
- 2 Wiring harness of metering pump, connector mounted
- 3 Hose section, 10 mm dia. clamp [2x]



**Connecting to metering pump**

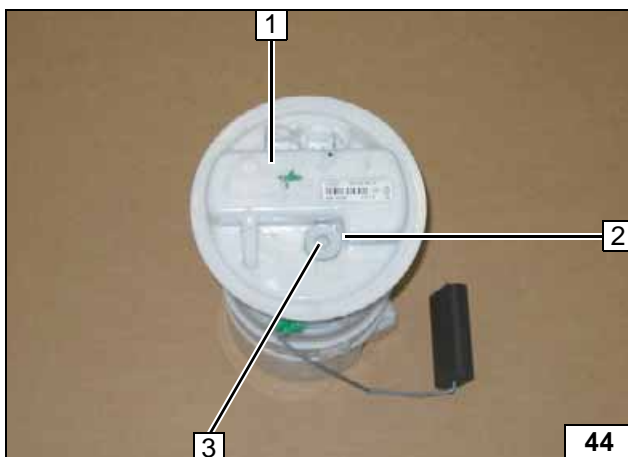

Remove fuel-tank sending unit 1 in accordance with manufacturer's specifications.

- 1 Fuel-tank sending unit
- 2 Lay on 6 mm dia. large diameter washer
- 3 Copy hole pattern, 6 mm dia. hole



**Removing fuel**

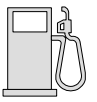

Shape fuel standpipe 1 according to template, cut to length and install.



**Installing fuel standpipe**

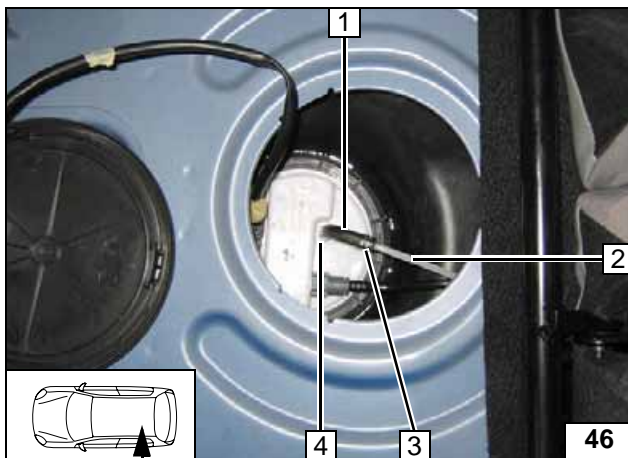

Install fuel-tank sending unit according to manufacturer's specifications.



**Connecting fuel line**

- 1 Molded hose, dia. 3.5 x 4.5
- 2 Fuel line
- 3 10 mm dia. clamp
- 4 8 mm dia. clamp

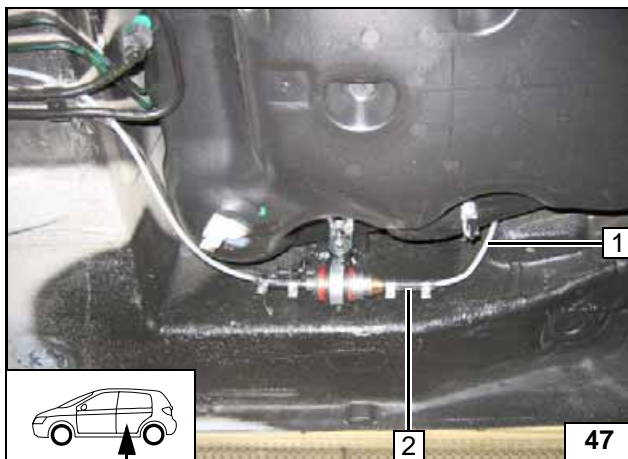

Check the position of the components; adjust if necessary. Check that they have free clearance.



**Connecting to metering pump**

- 1 Fuel line
- 2 Hose section, 10 mm dia. clamp [2x]



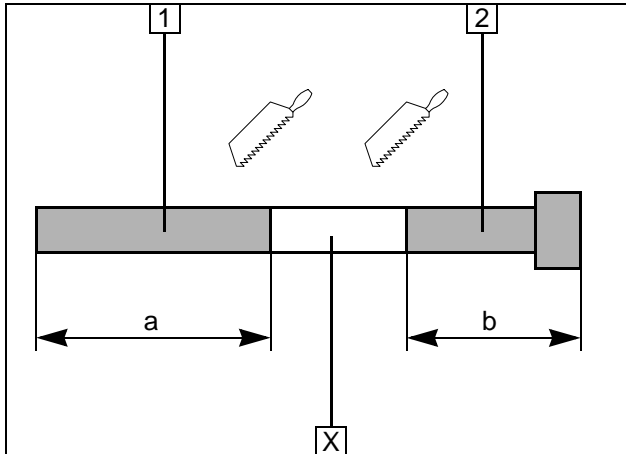
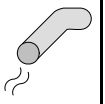

**Exhaust gas**

- 1 Exhaust pipe  
a = 400
- 2 Exhaust end section  
b = 230

Discard section X

**Preparing exhaust pipe**

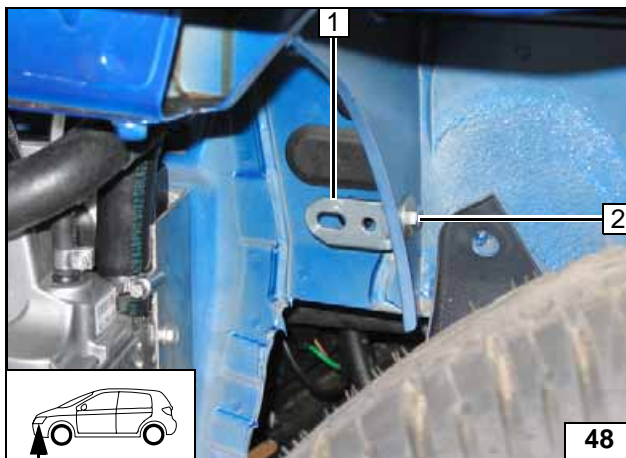

- 1 Angle bracket
- 2 M6x20 bolt, large diameter washer, original vehicle hole, flanged nut

**Installing muffler**

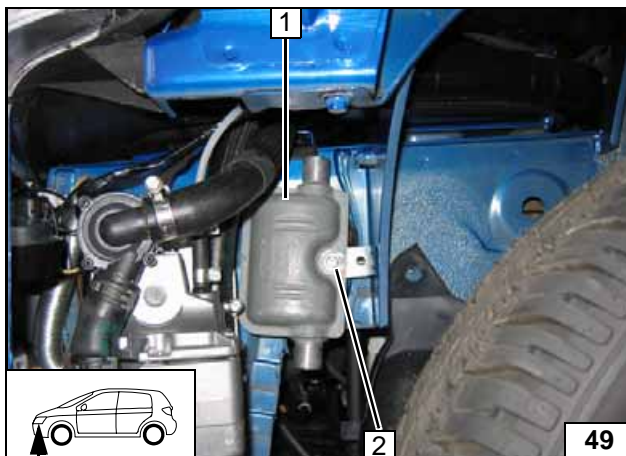

- 1 Muffler
- 2 M6x20 bolt, flanged nut

**Installing muffler**

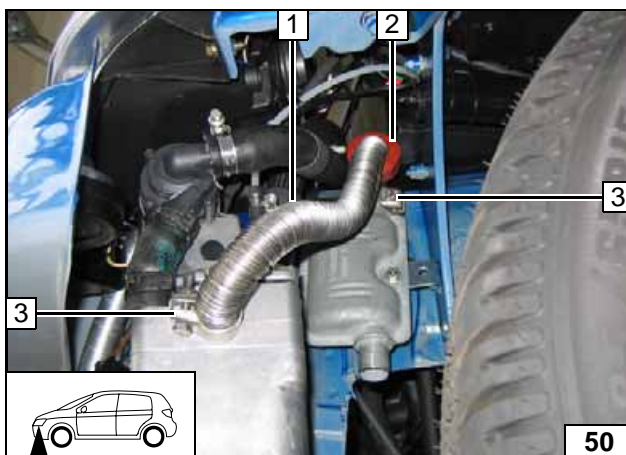

- 1 Exhaust pipe
- 2 Red (rt) rubber isolator
- 3 Hose clamp [2x]

**Installing exhaust pipe**

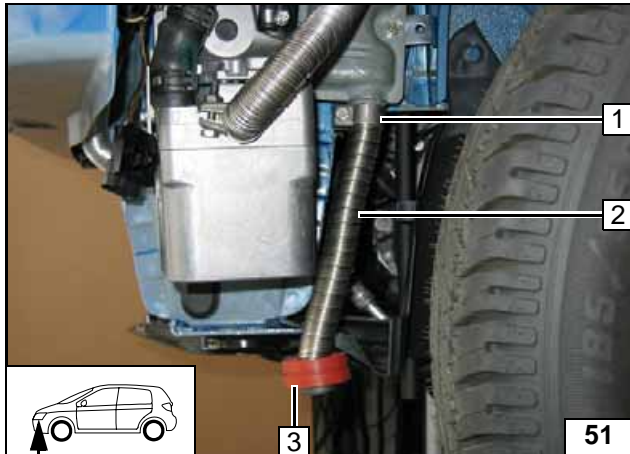
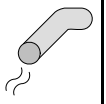

- 1 Hose clamp
- 2 Exhaust end section
- 3 Red (rt) rubber isolator with groove

**Installing end section**

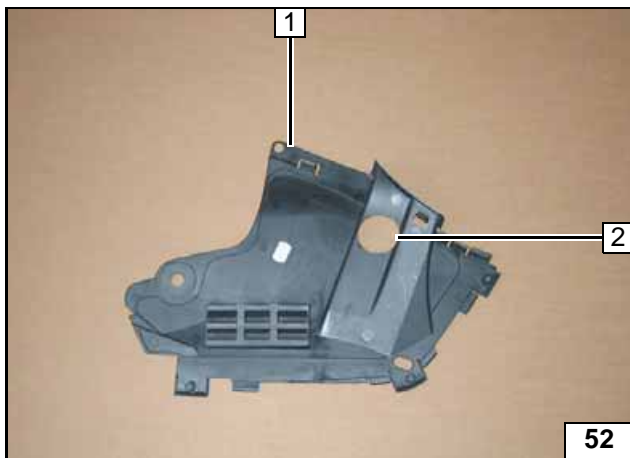

- 1 Trim piece
- 2 42 mm dia. hole



**Drilling trim**

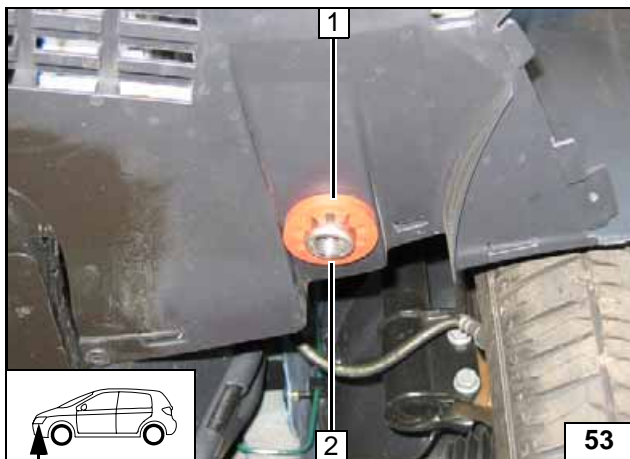

Align exhaust end section 2 flush on red rubber isolator 1.



**Mounting rubber isolator**



## Final Work

### WARNING!

Reassemble the disassembled components in reverse order.

Check all hoses, clamps and all electrical connections for firm seating.

Secure all loose cables using cable ties.

Only use manufacturer-approved coolant.

Spray heater unit components with anti-corrosion wax (Tectyl 100K, Order No. 111329).

- Connect the battery.
- Fill and bleed the coolant circuit according to the vehicle manufacturer's specifications.
- Set the digital timer.
- Make settings on A/C control panel according to the "Operating Instructions for End Customer".
- Check the proper operation of the additional heater, see the operating instructions/installation instructions.
- Attach the "Switch off additional heater before refueling" sticker to the left-hand B-pillar.



Webasto AG  
Postfach 80 - 82132 Stockdorf  
Hotline 01805 / 932278 - Hotfax 0395 / 5592-353  
<http://www.webasto.de>

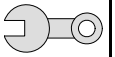

Template for Fuel Standpipe

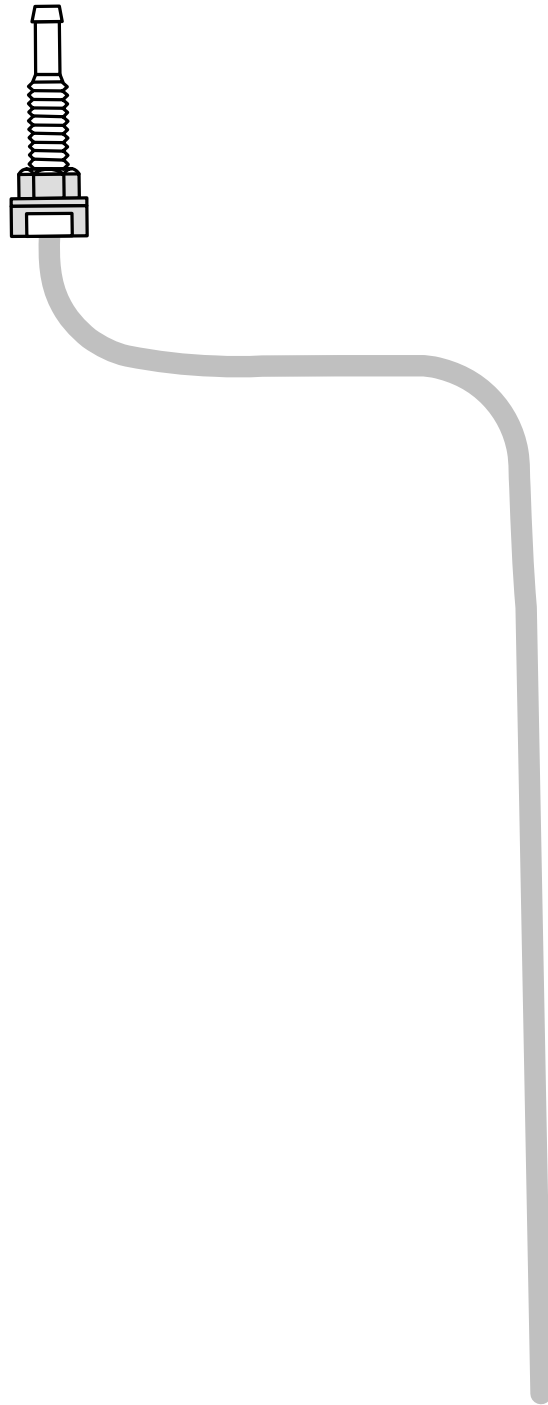

100 mm



Scale 1:1

Compare the size of the printed version with dimension lines.

Permitted tolerance a maximum of 2%.

Set the printer settings to "no margin" or "minimize margins" and 100% of the normal size.

100 mm

0

**Operating Instructions for End Customer**



Please remove page and add to the vehicle operating instructions.



**Note:**

We recommend matching the heating time to the driving time.

Heating time = driving time

**Example:**

For a driving time of approx. 20 min. (in one direction), we recommend not exceeding a switch-on time of 20 min.

If the summer/winter switch option has been installed, this must be switched in accordance with the time of year. The heater unit will then only switch on the vehicle fan to ventilate the vehicle interior in the position Winter  heat and in the position Summer .

Before parking the vehicle, make the following settings:

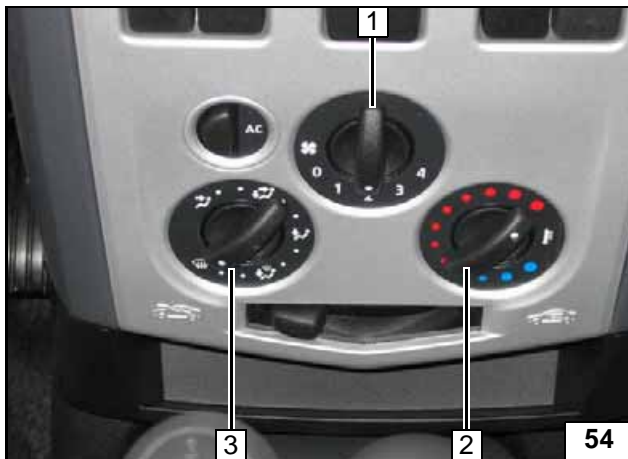

**Dacia Logan**

- 1 Set fan to level "1", or possibly "2"
- 2 Set temperature to "max."
- 3 Direct air outlet toward windshield

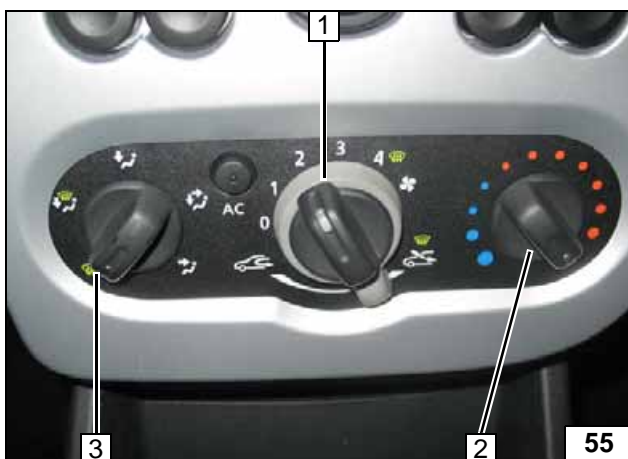

**Dacia Sandero**

- 1 Set fan to level "1", or possibly "2"
- 2 Set temperature to "max."
- 3 Direct air outlet toward windshield

Manual air conditioning

Manual air conditioning