

Water Heater Unit



Thermo Top E Additional Heater ^{e1} 00 0003

Installation Instructions

Opel Meriva

Diesel
from Model Year 2006
Left-hand drive vehicle



WARNING!

Hazard warning:

Incorrect installation or repair of Webasto heating systems may cause a fire or result in the emission of carbon monoxide, which can be fatal. Serious or fatal injuries can be caused as a result.

Specialist company training, technical documentation, specialized tools and equipment are required to install and repair Webasto heating and cooling systems.

NEVER attempt to install or repair Webasto heating or cooling systems if you have not successfully completed the company training and thereby acquired the required technical skills, or if you do not have access to the required technical documentation, tools and equipment needed to carry out correct installation and repairs.

ALWAYS follow all Webasto installation and repair instructions and observe all warnings.

Webasto does not accept any liability for defects and damage that are attributable to installation by untrained staff.

Table of Contents

Validity	2	Preparing installation location	13
Heater Unit/Delivery Scope	3	Preparing heater unit	15
Foreword	3	Exhaust gas	16
General Instructions	3	Installing heater unit	17
Special Tools	3	Coolant on 1.3 D	19
Explanatory Notes on Document	4	Coolant on 1.7 D	22
Preliminary Work	5	Combustion air	26
Heater unit installation location	5	Fuel	27
Preparing electrical system	6	Final Work	30
Electrical system	7	Template for Fuel Standpipe	31
Fan controller for manual air conditioning	8	Operating Instructions for End Customer	32
Automatic air-conditioning fan controller	9		
Vehicles with passenger compartment monitoring	10		
Remote option (Telestart)	11		
Remote option (Thermo Call)	12		

Validity

Manufacturer	Model	Type	EG-BE No./ABE
Opel	Meriva	X 01 Monocab	e1 * 2001/116 * 0215 *

Engine type	Engine model	Output in kW	Displacement in cm ³
Z13DT	Diesel	55	1248
Z17DTR	Diesel	74	1686
Z17DT	Diesel	92	1686

Vehicle and engine types, equipment variants and national specifications not listed in these installation instructions have not been tested. However, installation according to these installation instructions may be possible.

The installation location of a digital timer and summer/winter switch should be confirmed with the end customer before installation.

Heater Unit/Delivery Scope

Quantity	Description	Order No.:
1	Opel-specific heater unit delivery scope	See Opel price list
1	Installation kit for Opel Meriva 1.3/1.7 Diesel	1310957B
	Opel Catalog No.	1734252

Other required parts:

Quantity	Description	Order No.:
1	Clamp for Fuel-Tank Sending Unit - Opel Catalog No.	5815084

Optional heater control:

Quantity	Description	Order No.:
1	Heater control	See Opel price list

Foreword

These installation instructions apply to OpelMeriva vehicles with a Diesel engine - for validity, see page 2 - from model year 2006 and later, assuming technical modifications to the vehicle do not affect installation, any liability claims excluded. Depending on the vehicle version and equipment, modifications may be necessary during installation with respect to these installation instructions.

However, the stipulations in the "installation instructions" and "operating and maintenance instructions" for the *Thermo Top C/P/E* must always be observed.

The corresponding rules of technology and any information from the vehicle manufacturer should be observed during the installation work.

General Instructions

Installation should be carried out according to the general, standard rules of technology. Unless specified otherwise, fasten hoses, lines and wiring harnesses to original vehicle lines and wiring harnesses using cable ties.

Sharp edges should be fitted with edge protectors (split-open plastic hose).

Spray unfinished body areas, e.g. drilled holes, with anti-corrosion wax (Tectyl 100K, Order No. 111329).

Special Tools

- Torque wrench for 2.0 - 10 Nm
- Hose clamping pliers
- Metric thread-setter kit
- Flexible socket wrench, 7 mm

Explanatory Notes on Document

To provide you with a quick overview of the individual working steps, you will find an identification mark on the outside top right corner of the page in question.

Mechanical system

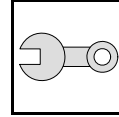

Electrical system

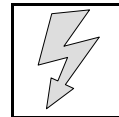

Coolant

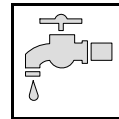

Fuel

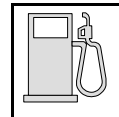

Exhaust gas

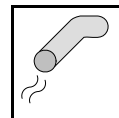

Combustion air

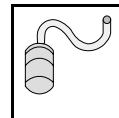

Special features are highlighted using the following symbols:



Specific risk of injury or fatal accidents.



Specific risk of damage to components.



Specific risk of fire or explosion.



Reference to general installation instructions of Webasto components or to the manufacturer's vehicle-specific documents.



Reference to a special technical feature.



The arrow in the vehicle icon indicates the position on the vehicle and the viewing angle.

All dimensions are in mm!

Tightening torque of hose clamps = 2.0 + 0.5 Nm!

Tightening torque of Ejet screws, Ejet studs = 10 Nm!

Preliminary Work

WARNING!

- Depressurize the cooling system.
- Copy the factory number from the original type label to the duplicate type label.
- Remove years that do not apply from the duplicate label.
- Attach the duplicate label (type label) in the appropriate place.
- Open fuel tank cap, ventilate tank.
- Close the tank cap again.
- Remove battery.
- Remove the engine cover.
- Remove the front coolant reservoir cap.
- Disconnect the fuse and relay box located on the front coolant reservoir cap.
- Detach the wheel well trim on the right and left.
- Remove the bumper.
- Remove the left-hand headlight.
- Remove the center section of the rear bench seat.
- Open the tank-fitting service lid.
- Remove the steering column trim.
- Remove the A-pillar trim in the driver's side footwell.
- Remove the glove compartment (only with Thermo Call).
- Remove the radio (only with manual air conditioning).
- Remove the A/C control panel according to the manufacturer's instructions (only with automatic air-conditioning)

Remove page 32 "Operating Instructions for End Customer" and add to the vehicle operating instructions.

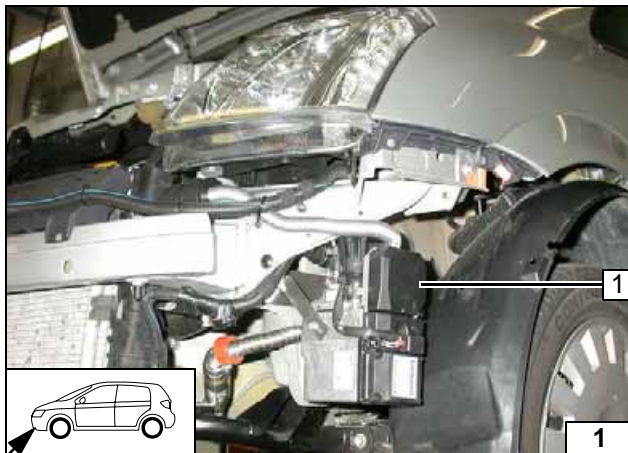

Heater unit installation location

- 1 Heater unit

Installation location

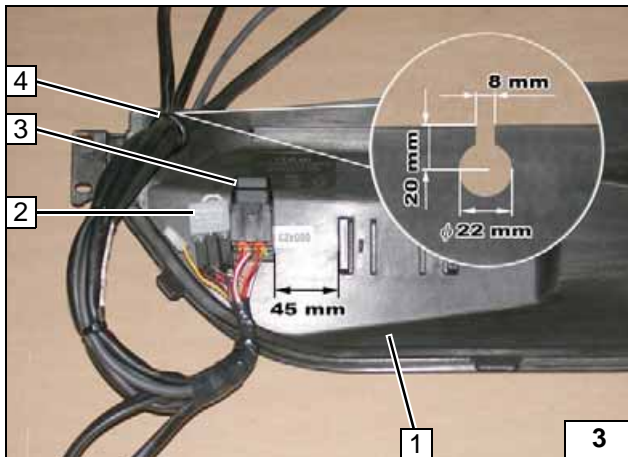
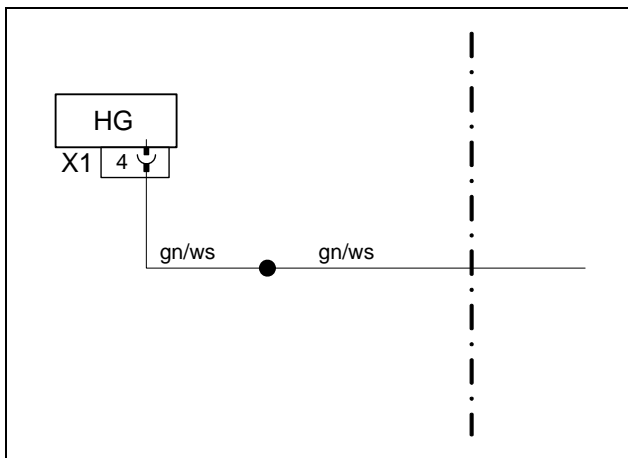
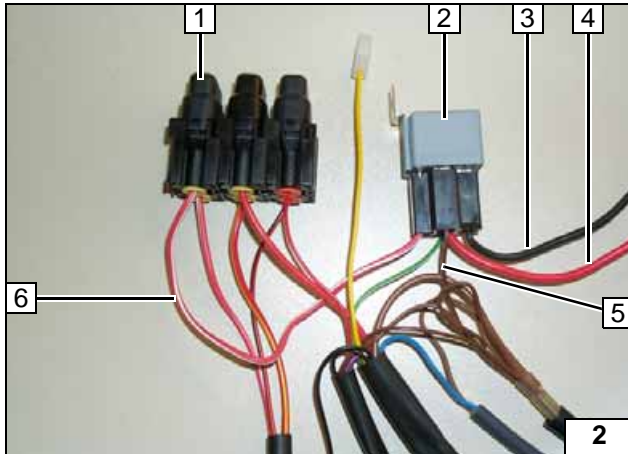

Preparing electrical system

Only with automatic air-conditioning

Uncrimp all lines from socket of K3 relay **2** (K3 relay is no longer required). Remove black (sw) **3** and red (rt) **4** wires from protective sleeving and discard (protective sleeving will be reused). Remove fuse F3 25A **1** (socket remains empty). Cut red/white (rt/ws) wire **6** from fuse F3 and discard. Insulate brown (br) ground wire **5** and tie back.

Connect green/white (gn/ws) wire from heater unit to 2,500 mm long green/white (gn/ws) wire with connector. Pull green/white (gn/ws) wire into protective sleeving.

Route all wiring harnesses except wiring harness of digital timer and fan controller through protective rubber plug **4** to outside.

- 1** Coolant reservoir cap
- 2** 5 mm dia. hole, K3 relay, blind spreader rivet (only with manual air conditioning)
- 3** 5 mm dia. hole, retaining plate of fuse holder, blind spreader rivet
- 4** 22 mm dia. hole, protective rubber plug (slot)



Adapting wiring harness



Extending green/white (gn/ws) wire



Installing fuse holder and fan relay



Electrical system

Wiring harness pass through

Remove cover of relay box.

1 Protective rubber plug, 10 mm dia. hole

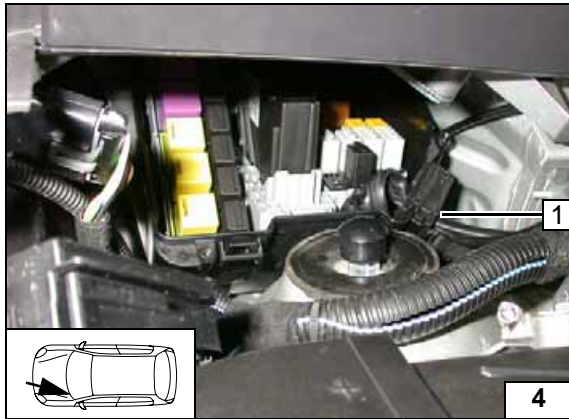

Digital timer, summer/winter switch option

- 1 Digital timer
- 2 Summer/winter switch, drilled hole 12 mm dia.

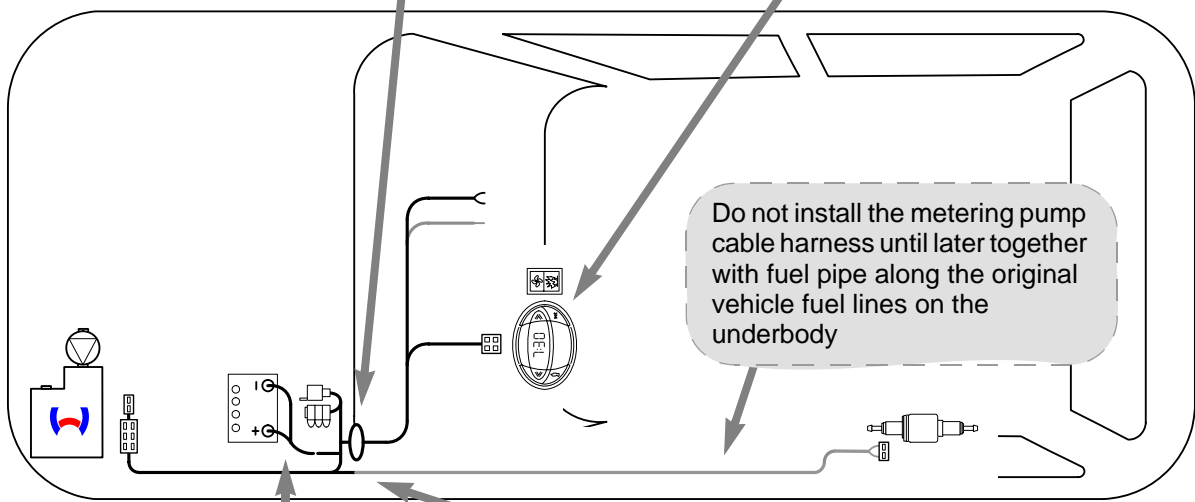
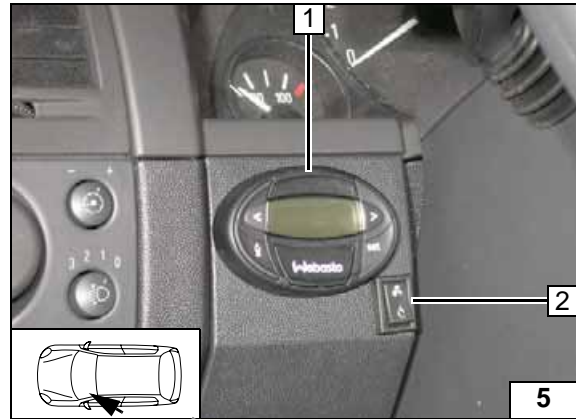

Wiring harness installation diagram

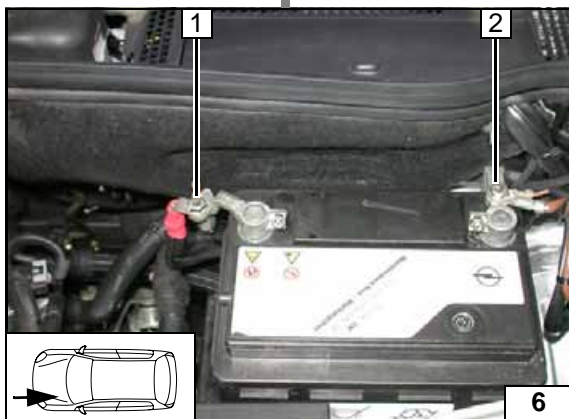

Positive and ground connection

- 1 Positive connection
- 2 Ground connection

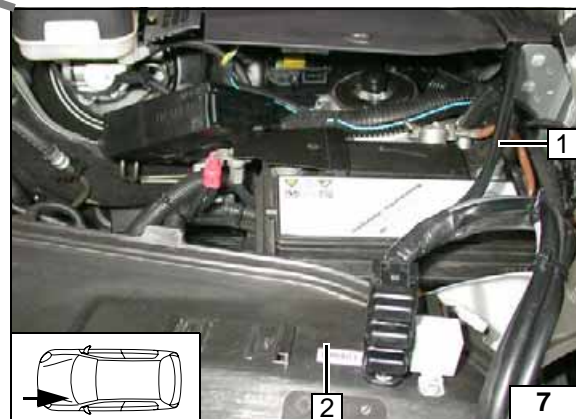

Installing wiring harnesses

Lay coolant reservoir cap 2 on engine block, then route wiring harnesses of digital timer and fan controller 1 through grommet into relay box and further into passenger compartment.



Fan controller for manual air conditioning

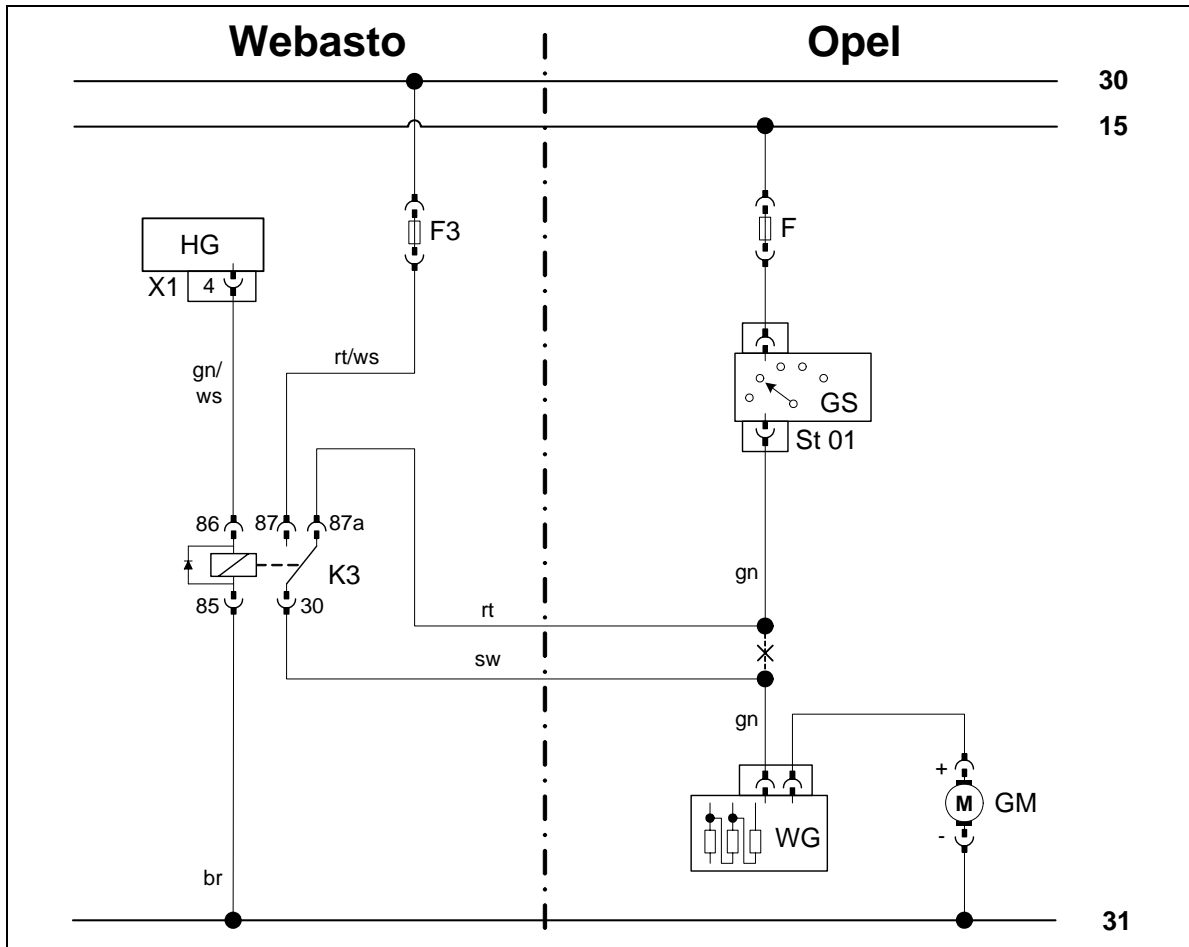

Wiring diagram

Webasto components		Vehicle components		Colors and symbols	
HG	Heater unit TT-C/E	GS	Fan switch	rt	red
X1	6-pin heater unit connector	St 01	12-pin connector GS	ws	white
F3	25 A fuse	WG	Resistor group	sw	black
K3	Fan relay	GM	Fan motor	br	brown
		F	Fuse	gn	green
				X	Cutting point
				Wiring colors may vary.	

Legend

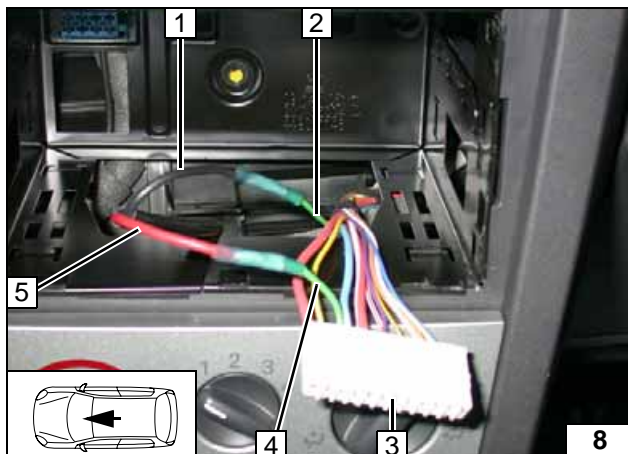

Connection on 12-pin connector 3 from fan switch stage 2.
Produce connections as shown in wiring diagram.

- 1 Black (sw) wire from K3/30
- 2 Green (gn) wire of resistor group
- 4 Green (gn) wire of connector
- 5 Red (rt) wire from K3/87a



**Connect-
ing fan
switch**



Automatic air-conditioning fan controller

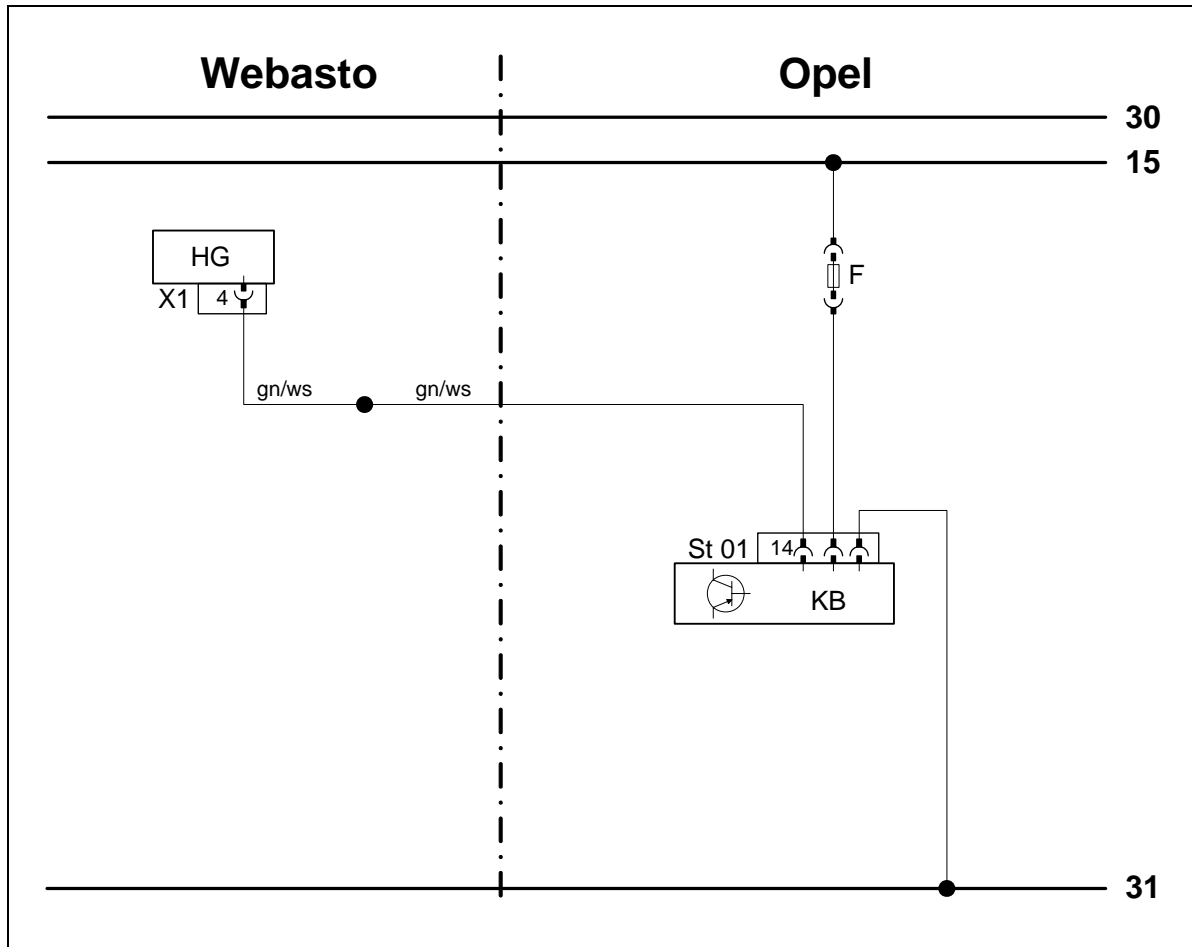

Wiring diagram

Webasto components		Vehicle components		Colors and symbols	
HG	Heater unit TT-C/E	KB	Air-conditioning control panel	gn	green
X1	6-pin heater unit connector	St 01	32-pin connector KB	ws	white
					Wiring colors may vary.

Legend

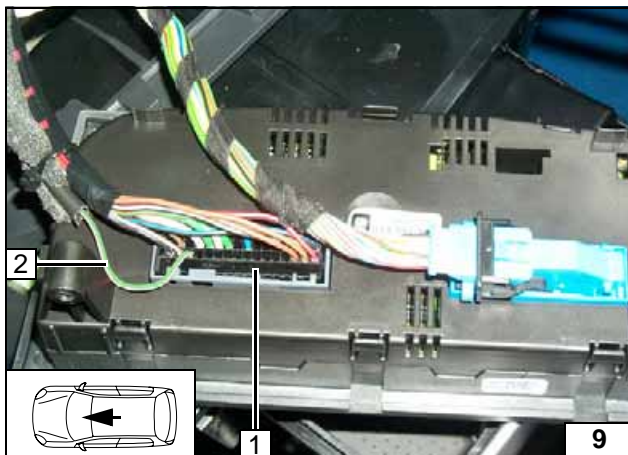

Connection on 32-pin connector 1 from A/C control panel (free socket, Pin 14). Produce connection according to wiring diagram with included plug-in contact.

2 Green/white (gn/ws) wire from heater unit

Connecting A/C control panel



Vehicles with passenger compartment monitoring

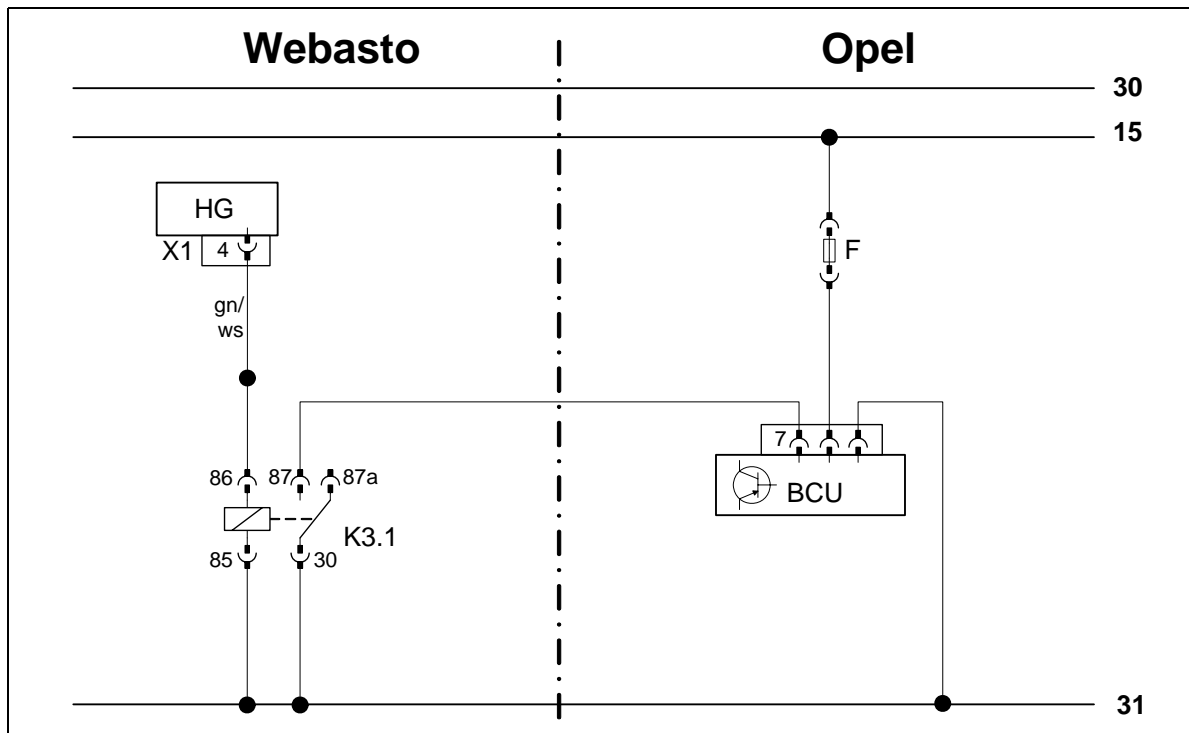

Wiring diagram

Webasto components		Vehicle components		Colors and symbols	
HG	Heater unit TT-C/E	BCU	Body control module	gn	green
X1	6-pin heater unit connector	F	Fuse	ws	white
				Wiring colors may vary.	

Legend

The variant coordination of the BCU must be reprogrammed from "not present" to "present" with Tech 2 (software version 12.600 - TIS 46) in the Additional heater submenu. To do this, remove the alarm control unit (installation location coolant reservoir on left) and integrate additional relay K3.1 in accordance with wiring diagram.



BCU variant coding

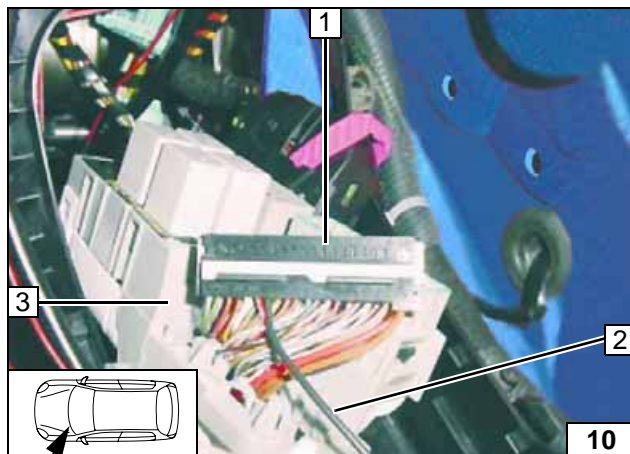

Connection on connector 1 from BCU 3 (free socket, Pin 7). Produce connection according to wiring diagram with included plug-in contact.

2 Wire from K3.1/87



Connecting BCU

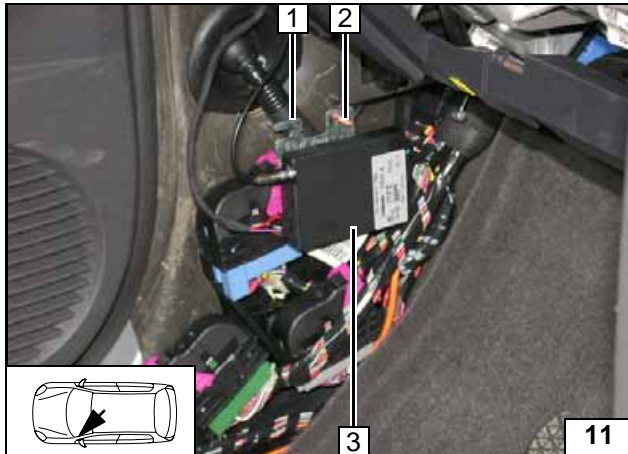
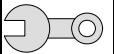

Remote option (Telestart)

Connect Telestart receiver **3** to bracket **1** and mount on original vehicle stud bolt **2** (will be fastened later with A-pillar trim).



Installing receiver

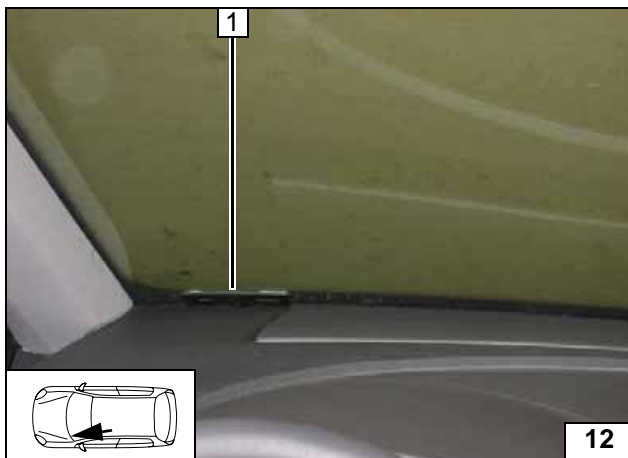

1 Antenna

Installing antenna

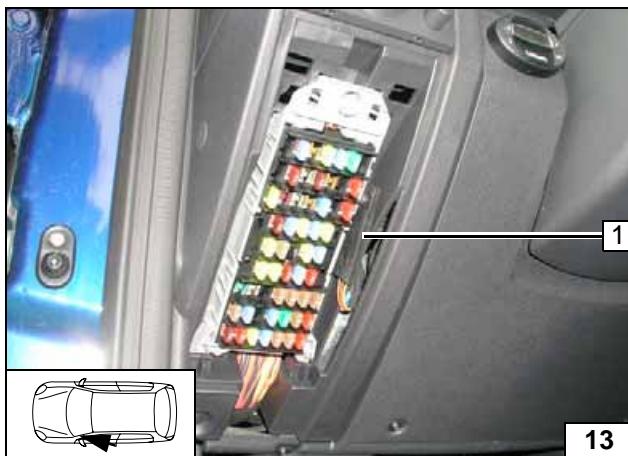

Temperature sensor for HTM100 only

1 Fasten temperature sensor with suitable means



Installing temperature sensor

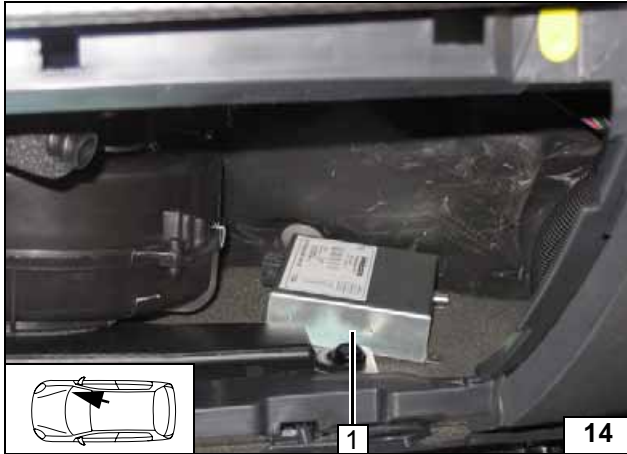
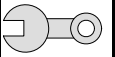

Remote option (Thermo Call)

1 Receiver, Velcro strip (self-adhesive)



Installing receiver

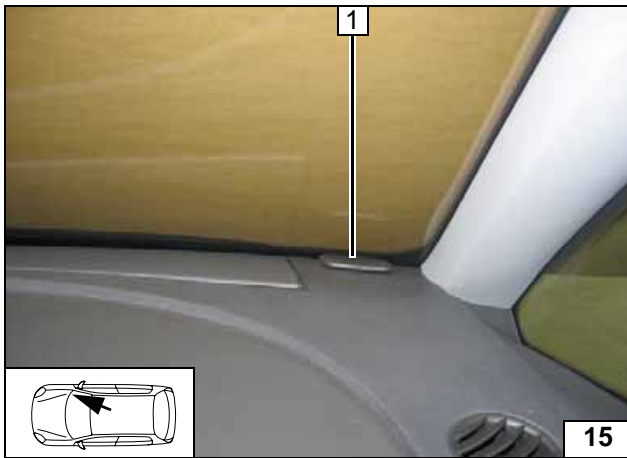

1 Antenna



Installing antenna

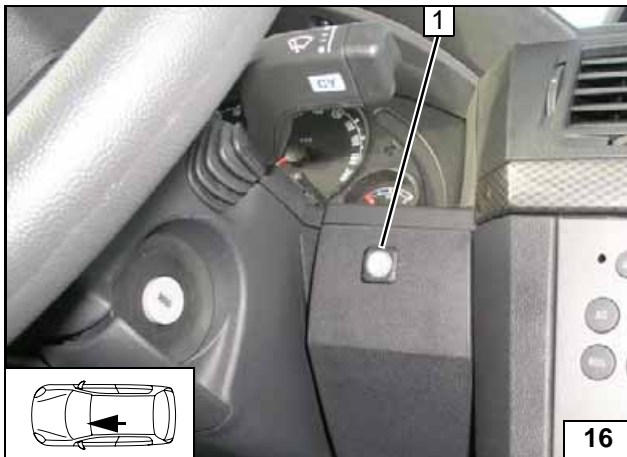

1 Push button, 16 mm dia. hole

Installing push button

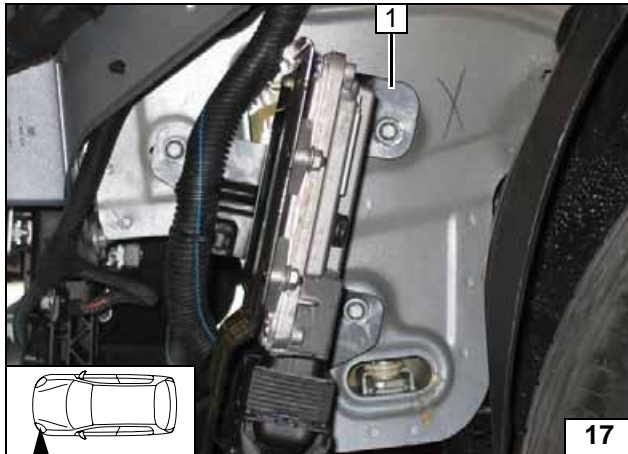
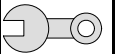

Preparing installation location

Remove control unit with bracket 1.
Discard bracket, Bolts will be reused!



Removing control unit

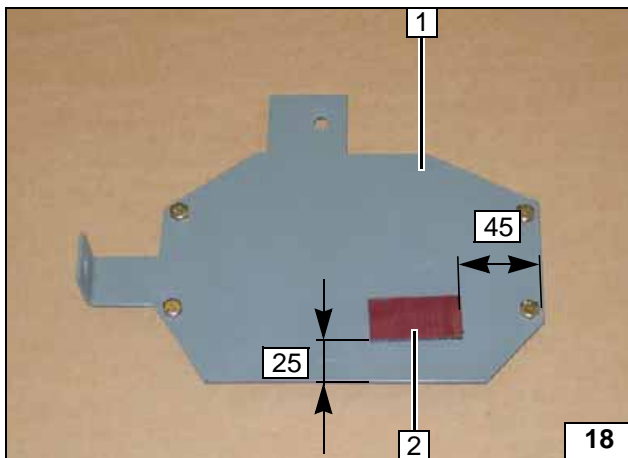

- 1 Control unit bracket
- 2 Velcro strip (self-adhesive)

Preparing control unit bracket

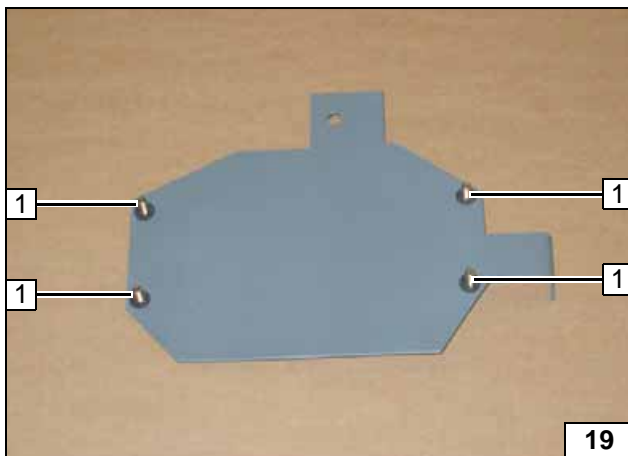

- 1 M6x16 bolt, pin lock [4x each]

Preparing control unit bracket

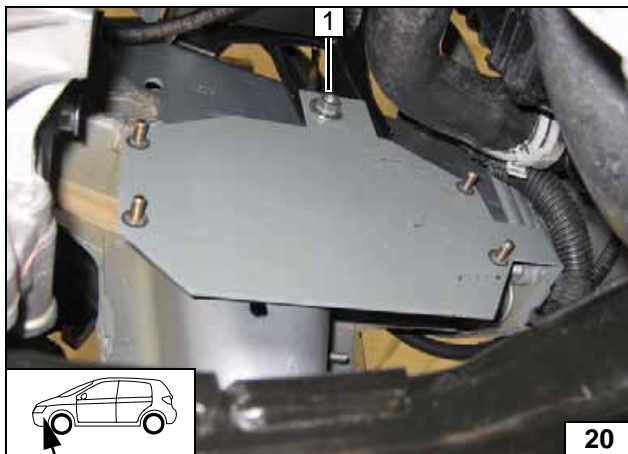

- 1 Original vehicle nut

Installing control unit bracket

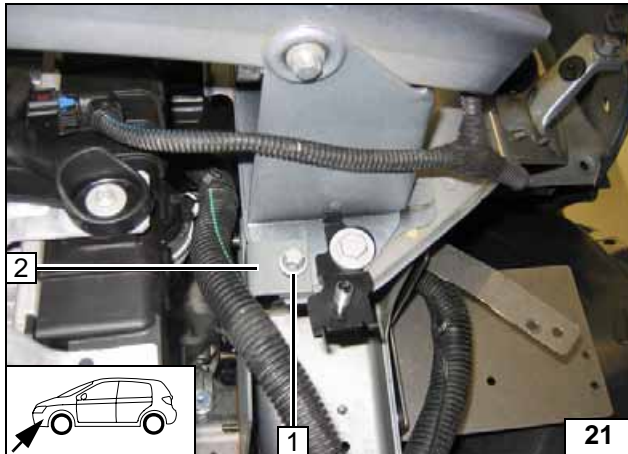
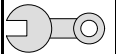

- 1 Original vehicle M8 bolt (Torx)
- 2 Tab of control unit bracket

Installing control unit bracket

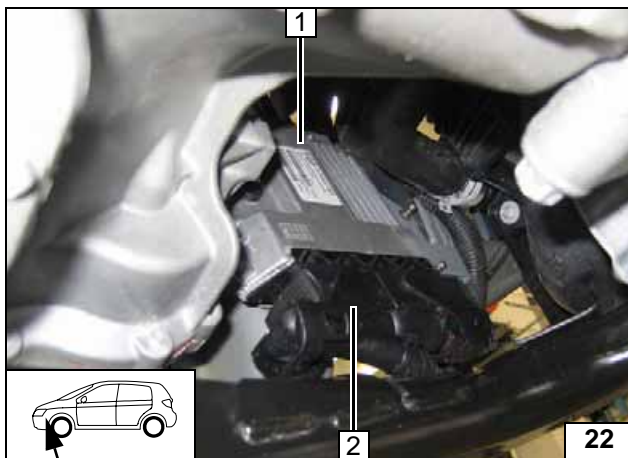

- 1 Control unit
- 2 Control unit connector

Connecting connector on control unit

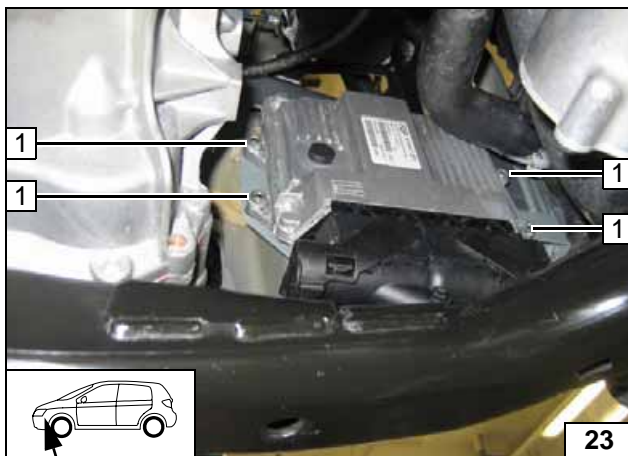

- 1 Original vehicle flanged nuts [4x] on premounted bolts

Installing control unit

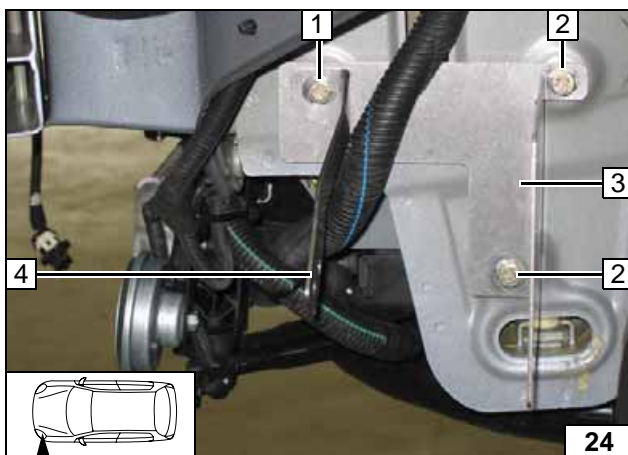

Install bracket of heater unit **3** together with strut **4**. Insert one 10 mm spacer sleeve each between bracket and frame side member.

- 1 M8x40 bolt, spring lockwasher, washer, 10 mm spacer sleeve on weld-in nut
- 2 M8x40 bolt, spring lockwasher, washer, 10 mm spacer sleeve [2x each] on weld-in nut



Installing bracket and strut

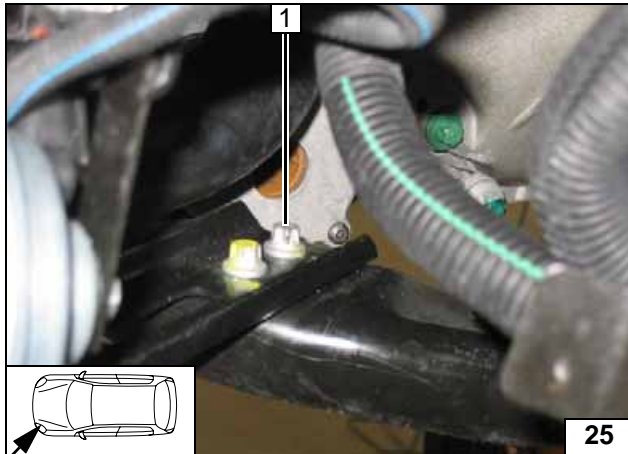
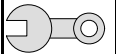

1.3 D

Remove rear original vehicle Torx screw 1 from frame side member.



Removing screw

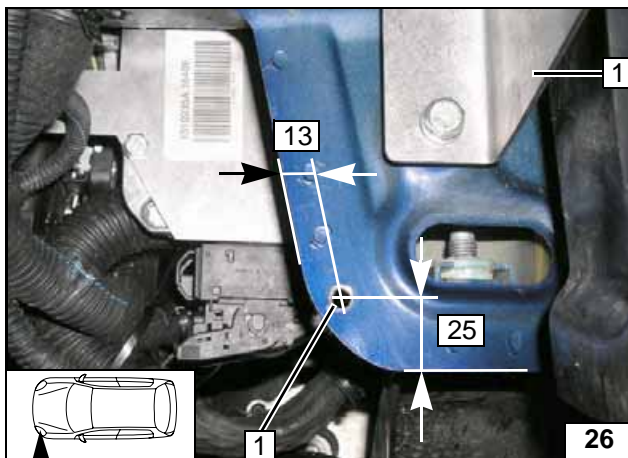

1.7 D

1 7 mm dia. hole

Hole for muffler mounting

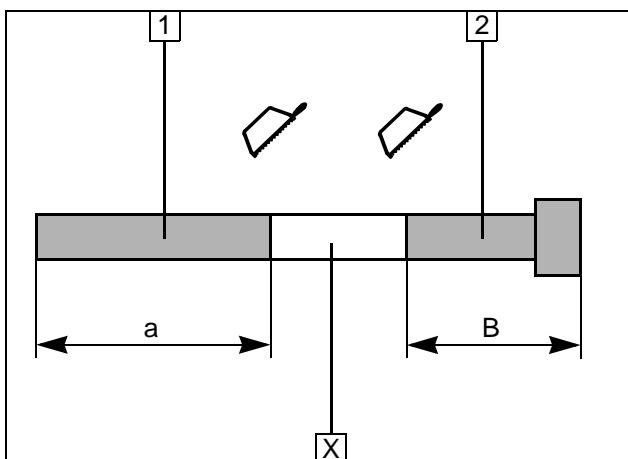

Preparing heater unit

1.3 D

- 1 Exhaust pipe
a = 270
- 2 Exhaust end section
b = 80

Discard section X

Preparing exhaust pipe

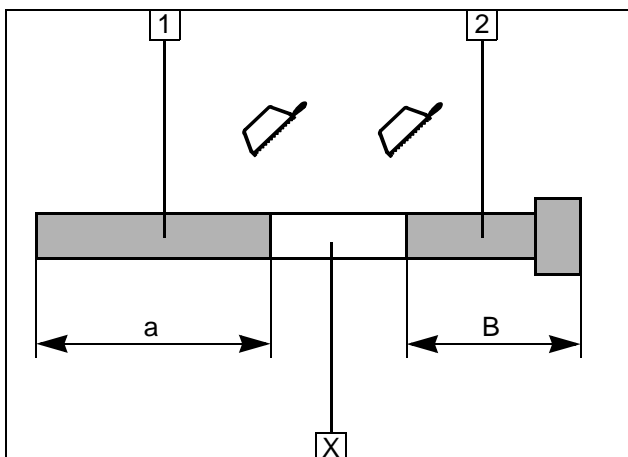

1.7 D

- 1 Exhaust pipe
a = 210
- 2 Exhaust end section
b = 50

Discard section X

Preparing exhaust pipe

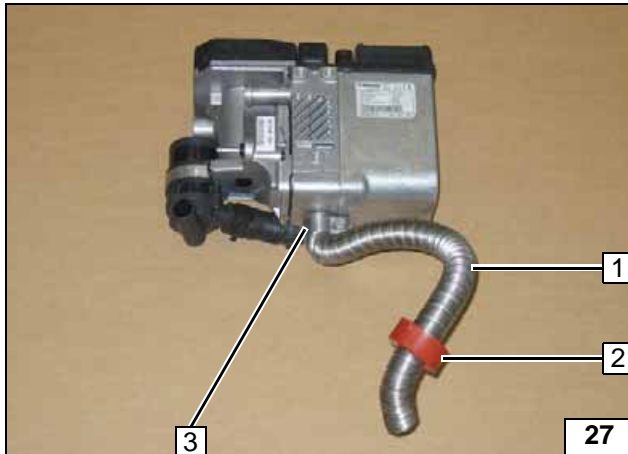
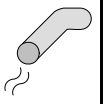

Exhaust gas

1.3 D

- 1 Exhaust pipe
- 2 Red (rt) rubber isolator
- 3 Hose clamp

Preassembling exhaust pipe

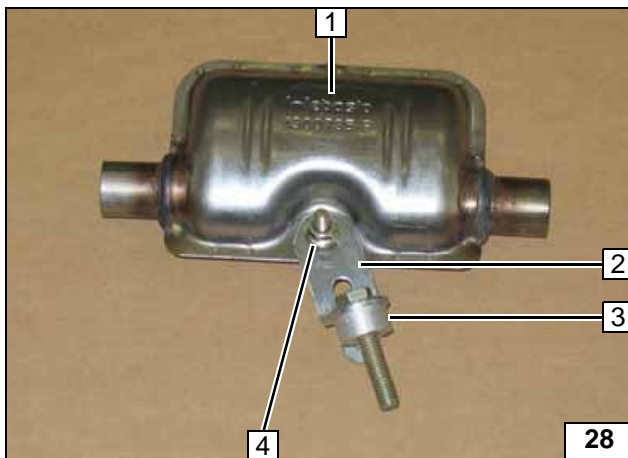

Drill out angle bracket 2 on short leg to 8.5 mm dia.



- 1 Muffler
- 3 M8x40 bolt, slide 10 mm spacer sleeve onto M8 bolt and secure against falling off
- 4 M6x20 bolt, flanged nut

Premounting muffler

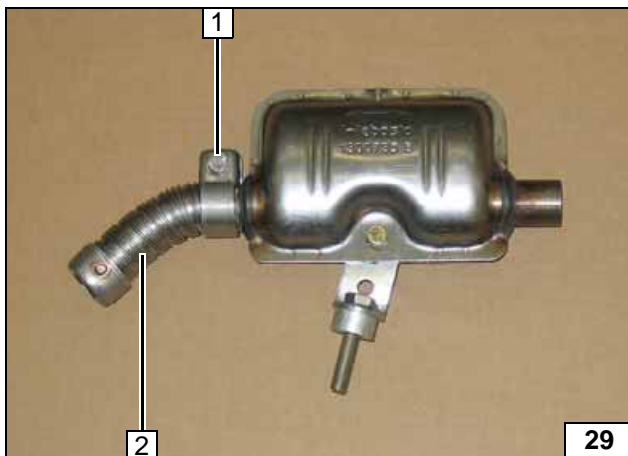

- 1 Hose clamp
- 2 Exhaust end section

Installing exhaust end section

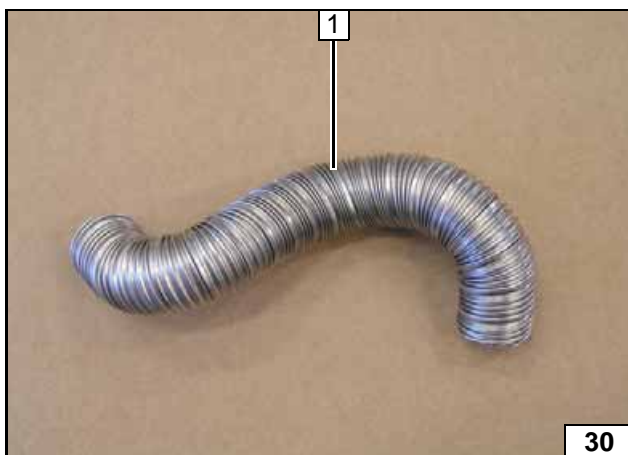

1.7 D

- 1 Exhaust pipe

Shaping exhaust pipe

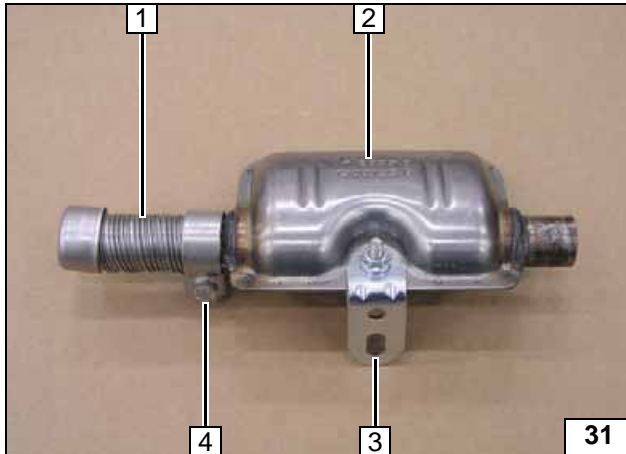
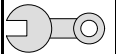

- 1 Exhaust end section
- 2 Muffler
- 3 Angle bracket, M6x20 bolt, flanged nut
- 4 Hose clamp

Premounting muffler

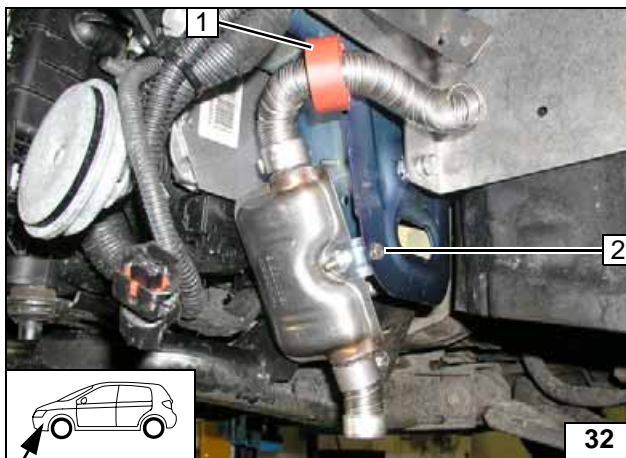

- 1 Red (rt) rubber isolator
- 2 M6x20 bolt, flanged nut

Installing exhaust system

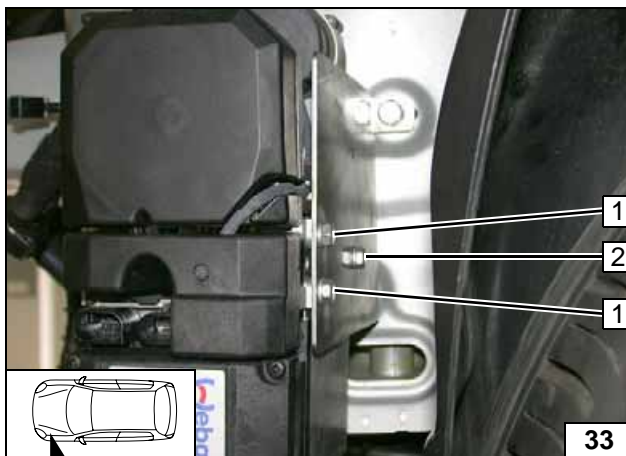

Installing heater unit

Align heater unit in driving direction.
Insert two washers between heater unit and bracket at position 2.

- 1 E-jot screw [2x]
- 2 E-jot screw, washer [2x]

Installing heater unit

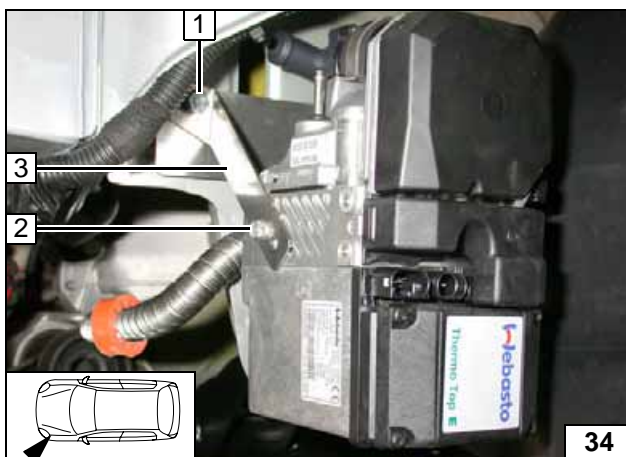

Tighten bolt at position 1.

- 2 E-jot screw
- 3 Strut

Installing heater unit

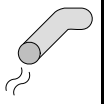

1.3 D

- 1 Pre-mounted bolt on original vehicle thread



**Installing
muffler**

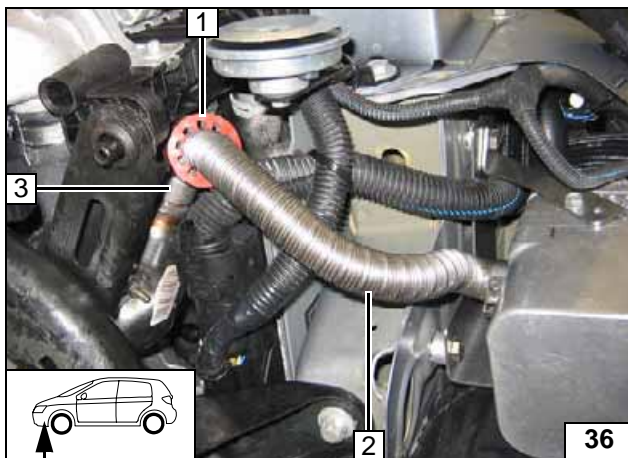

Ensure sufficient distance to adjacent components; correct if necessary.

- 1 Position red (rt) rubber isolator
- 2 Preassembled exhaust pipe
- 3 Hose clamp



**Connect-
ing ex-
haust line**

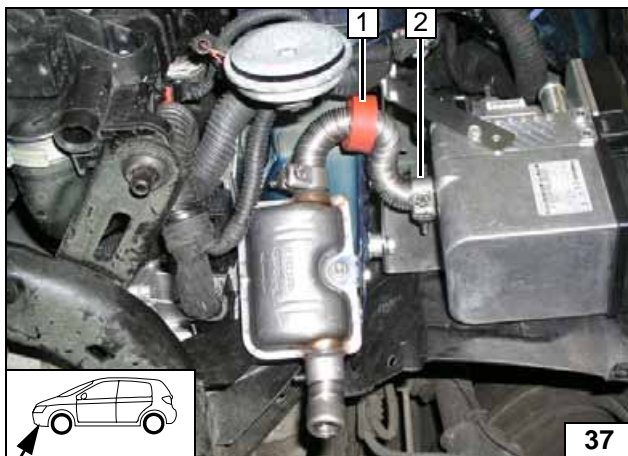

1.7 D

- 1 Position red (rt) rubber isolator
- 2 Hose clamp

**Connect-
ing ex-
haust line**



Coolant on 1.3 D

WARNING!

Any coolant running off should be collected using an appropriate container. Install hoses so that they are kink-free. Unless specified otherwise, always fasten using cable ties. Position clamps so that no other hose can be damaged! When installing the coolant hose, the heater unit must be filled with coolant.

The connection should be "inline" based on the following diagram:

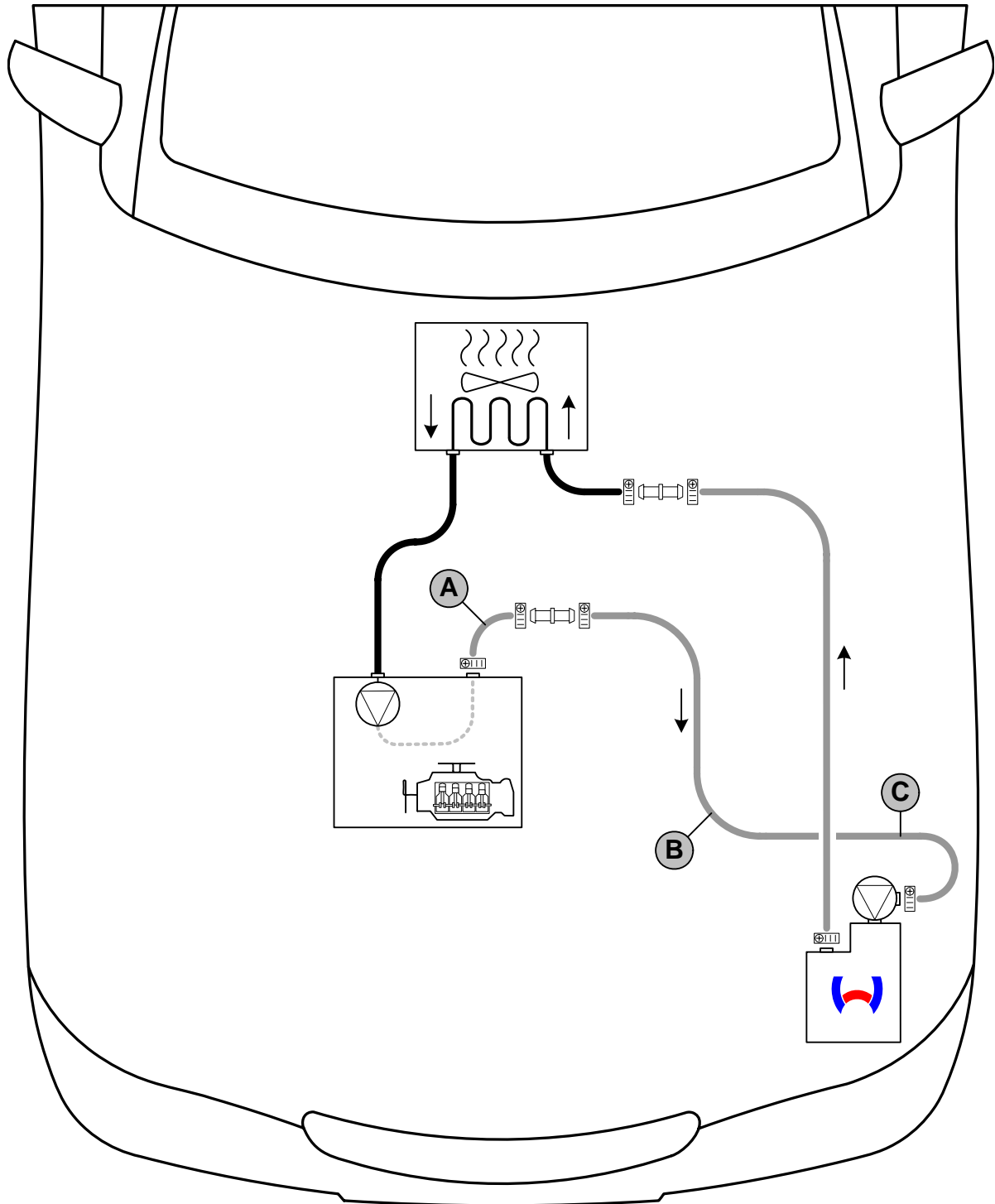

Coolant routing diagram

All connecting pipes  = 20x20 dia.
 All hose clamps  = 20-27 mm dia.!



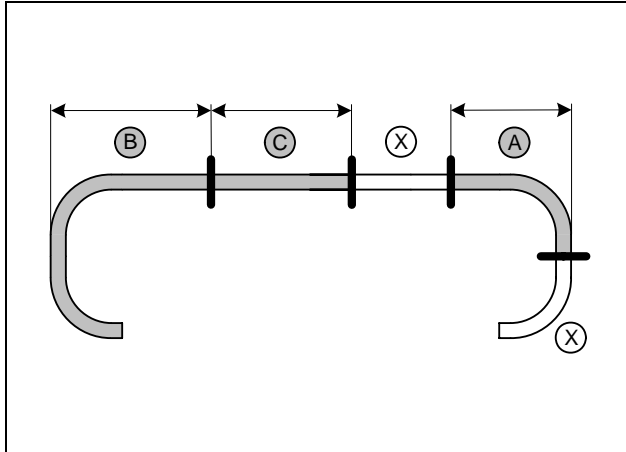

a = 110
b = 720
c = 840

Discard section X

Cutting coolant hoses to length

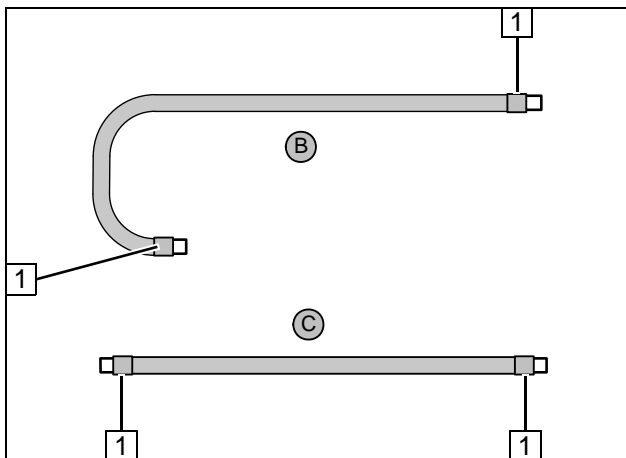

Push braided protection hoses onto hose B and C and cut to length. Cut heat shrink plastic tubing to length.



1 25 mm heat shrink plastic tubing [4x]

Preparing coolant hoses

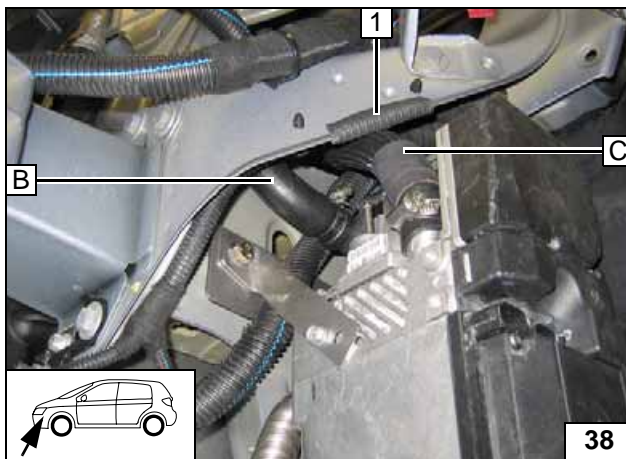

1 Edge protection

Connection on heater unit

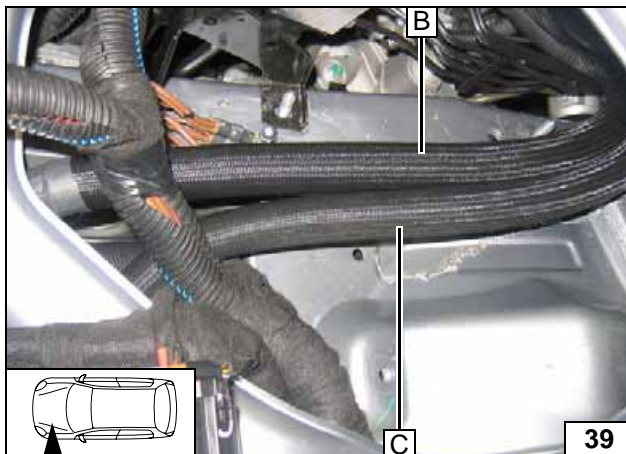

Routing in engine compartment

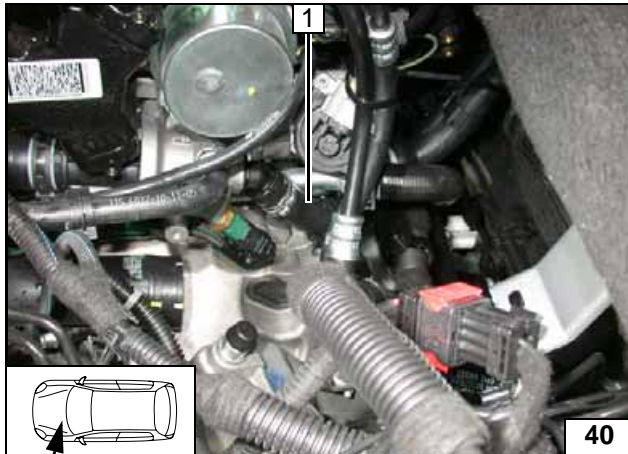

1 Disconnect hose from engine outlet

Cutting point

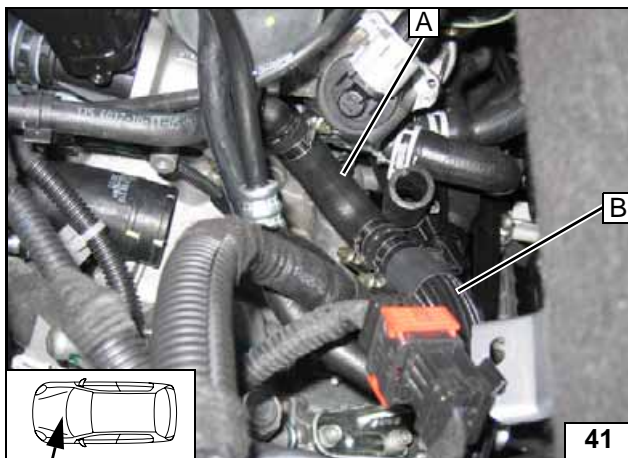

Hose A with long leg on connection piece on engine outlet.



Connection to engine outlet

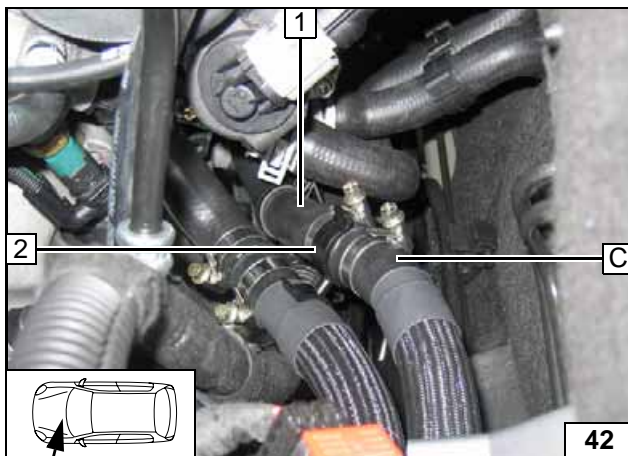

Before connecting, fill the coolant hoses with coolant.

- 1 Hose to heat exchanger inlet
- 2 Spacer bracket



Connection on heat exchanger inlet

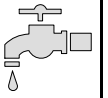

Coolant on 1.7 D



WARNING!

Any coolant running off should be collected using an appropriate container. Install hoses so that they are kink-free. Unless specified otherwise, always fasten using cable ties. Position clamps so that no other hose can be damaged! When installing the coolant hose, the heater unit must be filled with coolant.

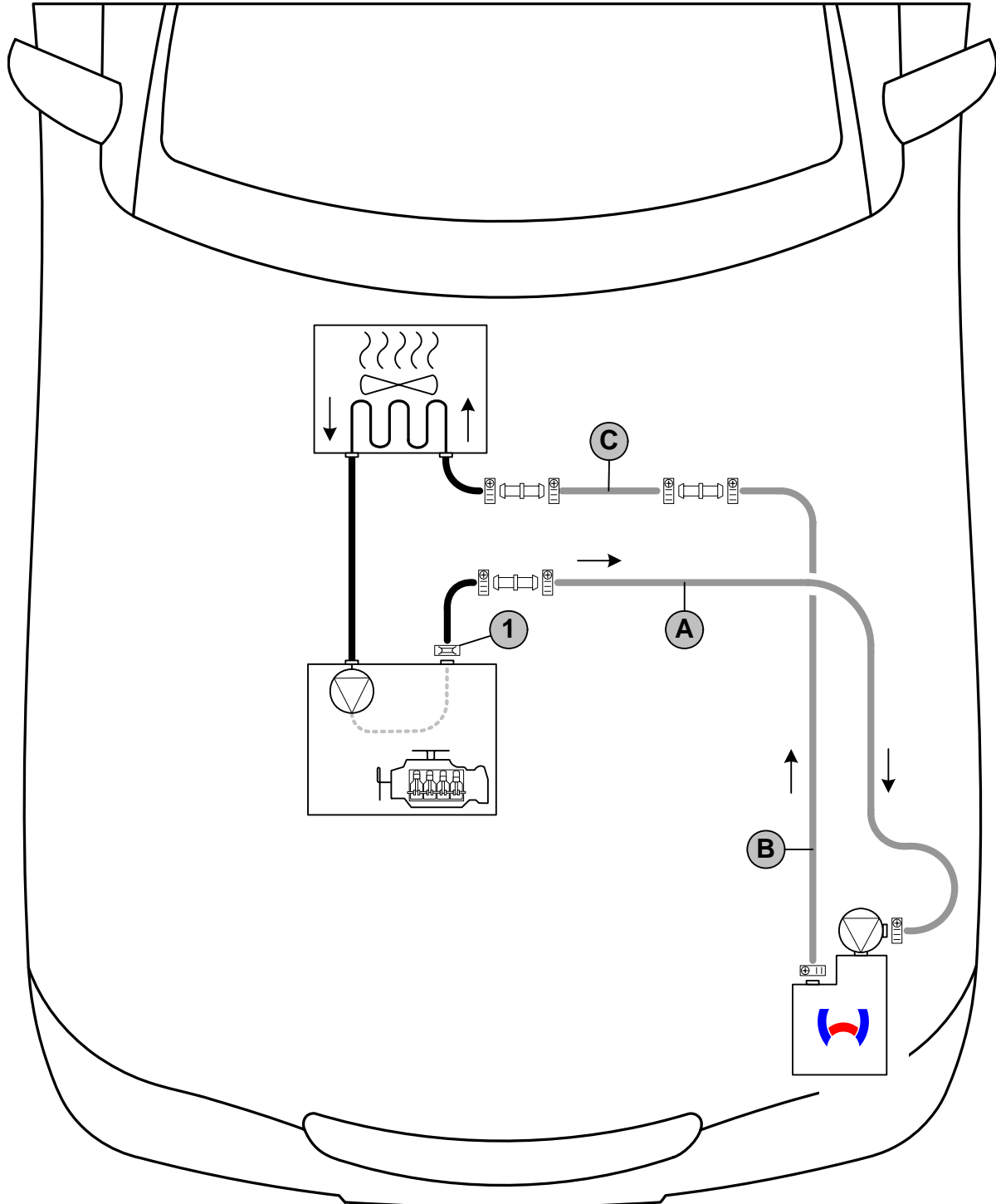
The connection should be "inline" based on the following diagram:



Coolant routing diagram

All connecting pipes  = 20x20 dia.
 All hose clamps  = 20-27 mm dia.!
 1 = Original vehicle spring clip .



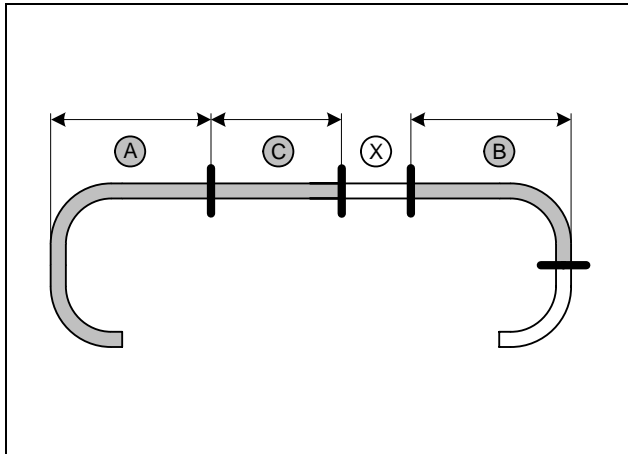

a = 970
b = 595
c = 500

Discard section X

Cutting coolant hoses to length

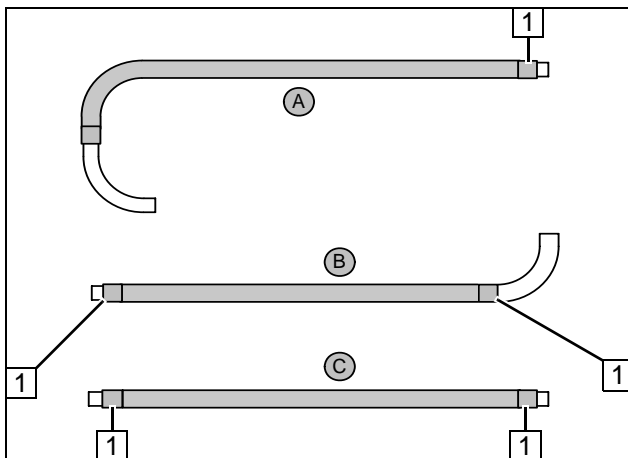

Push braided protection hoses onto hose **A**, **B** and **C** and cut to length.
Cut heat shrink plastic tubing to length.

1 25 mm long heat shrink plastic tubing [6x]



Preparing coolant hoses

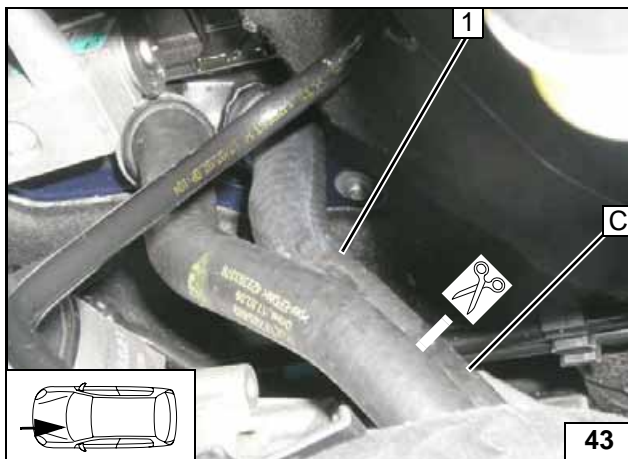

Remove original vehicle spacer over cutting point; will be remounted later.

1 Hose section of heat exchanger inlet
2 Engine outlet hose section



Cutting point

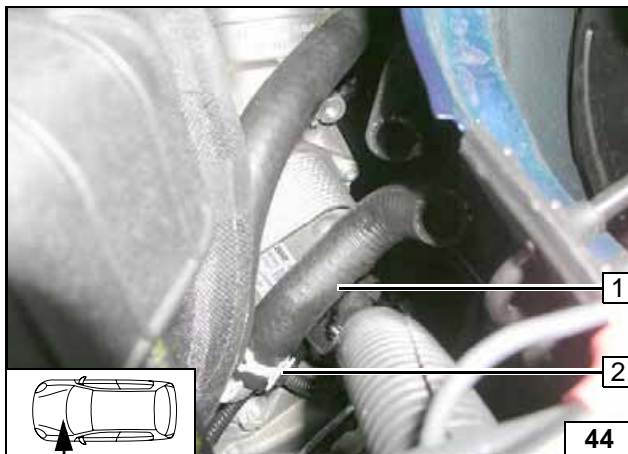

Loosen spring clip **2**, turn hose section on engine outlet **1** with elbow to left side of vehicle.



Turning hose elbow

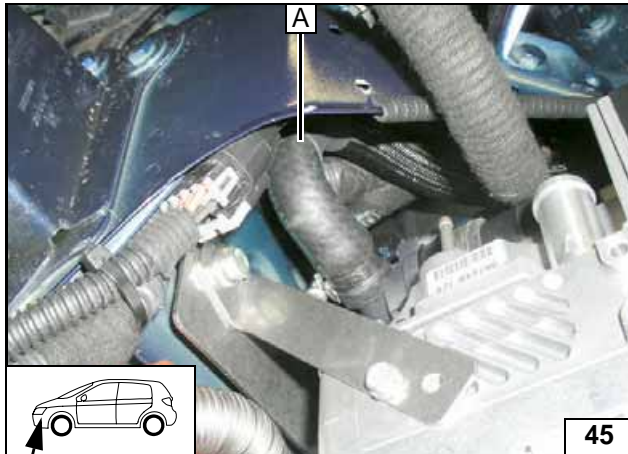

Connect-
ing heater
unit

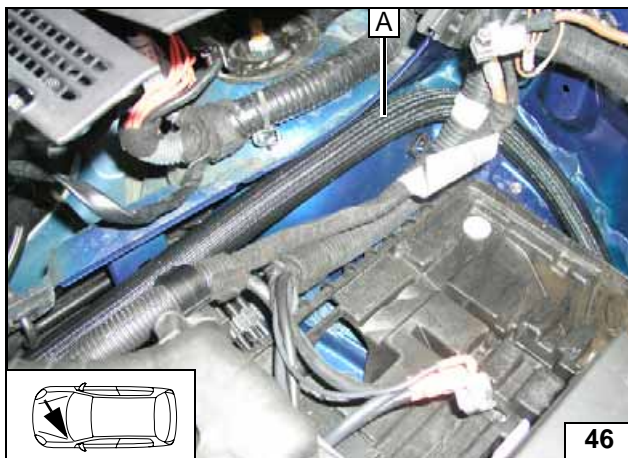

Routing in
engine
compart-
ment

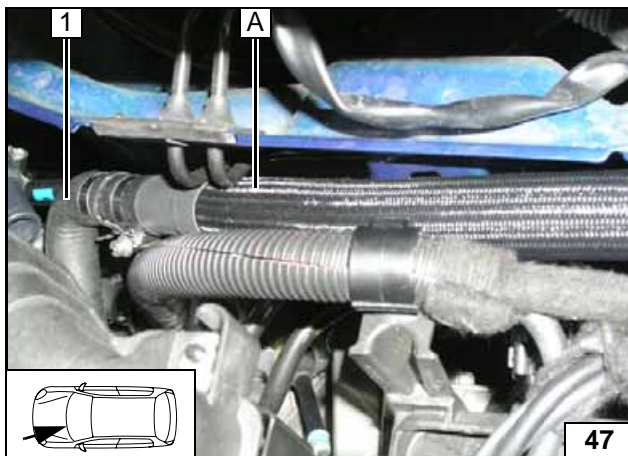

1 Hose on engine outlet turned

Conne-
ction on en-
gine outlet

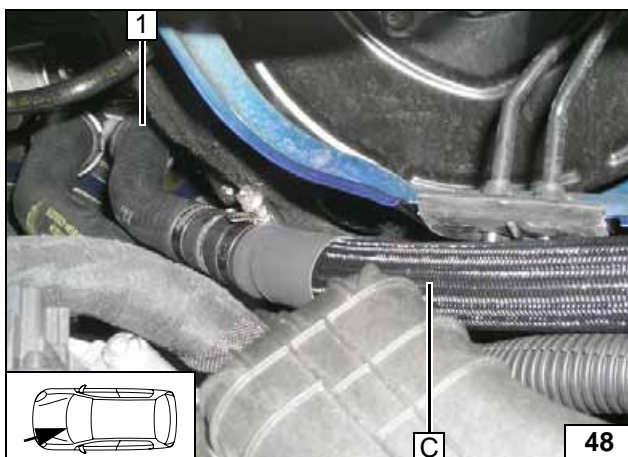

1 Hose on heat exchanger inlet

Conne-
ction on
heat ex-
changer in-
let

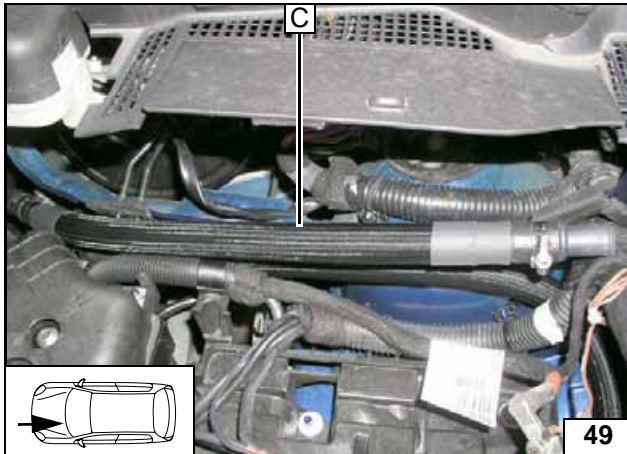

Routing in engine compartment

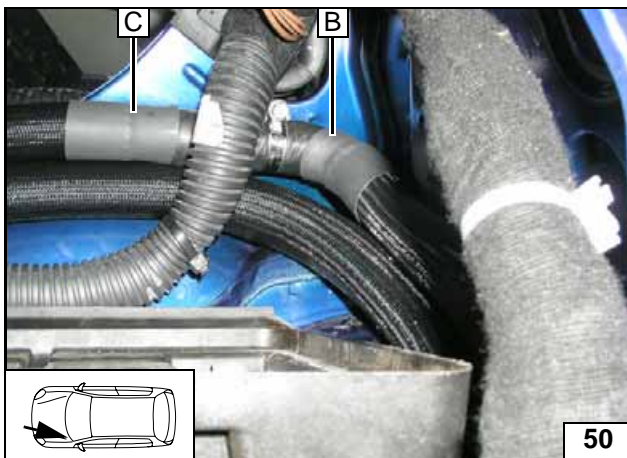

Routing in engine compartment

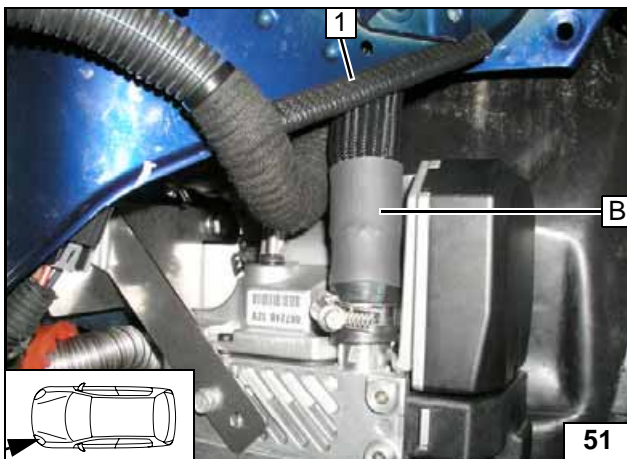

1 Edge protection

Connecting heater unit

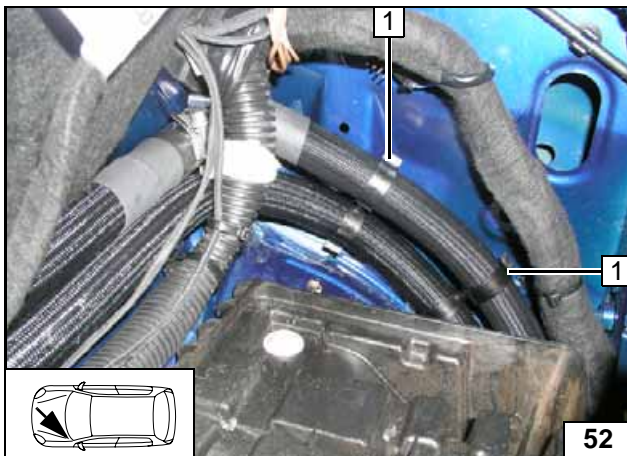

Ensure sufficient distance to neighboring components.

1 Spacer bracket [2x]



Positioning spacer

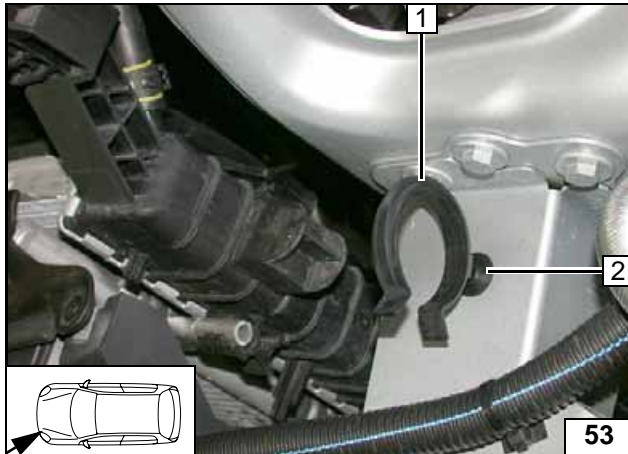
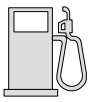

Combustion air

Drill 6,2 mm dia. hole in cross member at position 2.

- 1 Retaining clip in hole



Hole of retaining clip

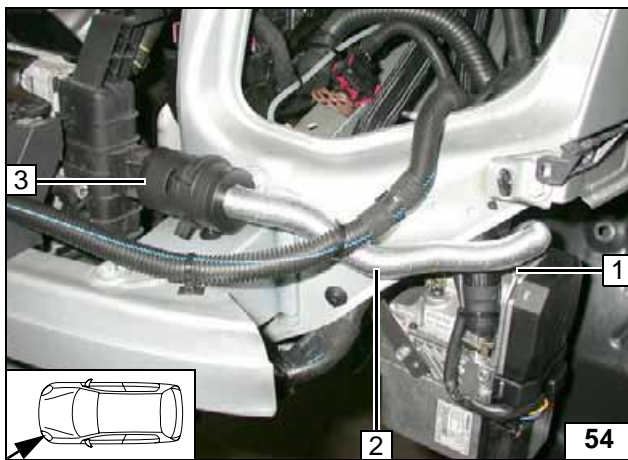

- 1 27 mm dia. hose clamp
- 2 Combustion-air intake pipe
- 3 Combustion-air intake muffler



Installing muffler

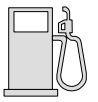

Fuel

CAUTION!

Open the vehicle's fuel tank cap, ventilate the tank and then re-close the tank lock.

Catch any fuel running off with an appropriate container.

Install fuel line and metering-pump wiring harness so that they are protected against stone impact. Unless specified otherwise, always fasten using cable ties. Mount the fuel line and wiring harness with rub protection on sharp edges.

WARNING!

The fuel line and wiring harness are routed to the metering pump in as shown in the wiring harness routing diagram.

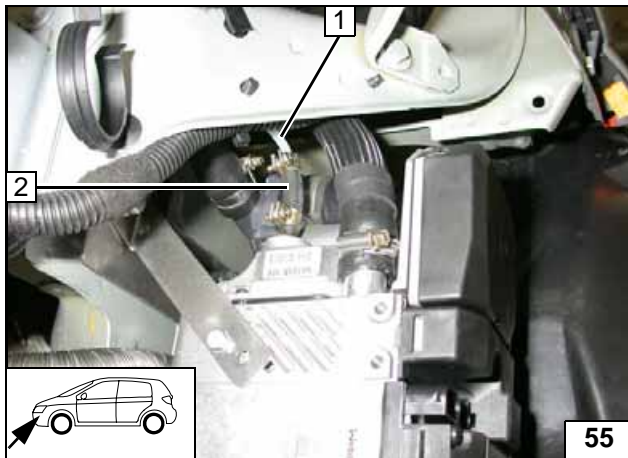

- 1 Fuel line
- 2 Hose section, 10 mm dia. hose clamp [2x]

Conne-
ction to
heater unit

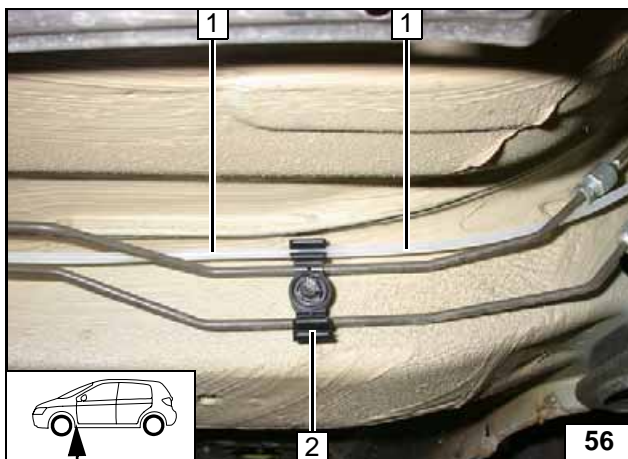

Replace original vehicle spacer bracket with spacer bracket provided 2 and clip in fuel line 1.



Installing
fuel line

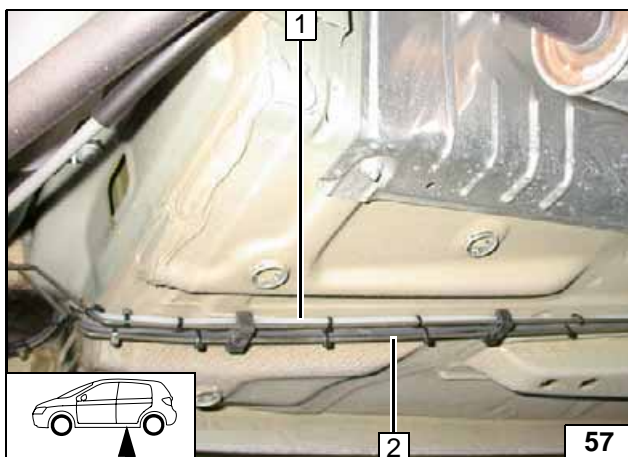

- 1 Fuel line
- 2 Metering pump wiring harness

Installing
lines

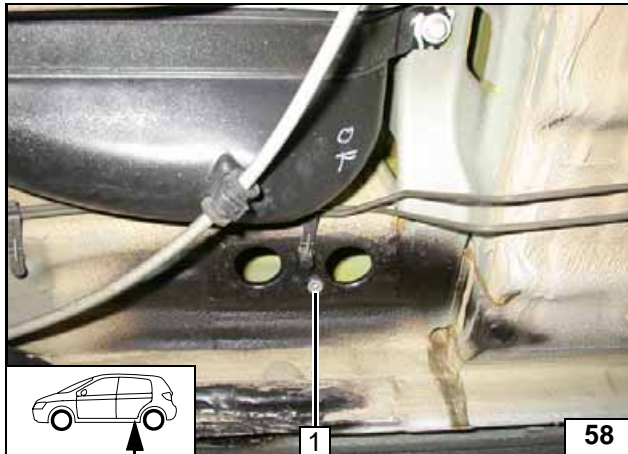

1 Drill 9.1 mm hole and mount rivet nut

Installing
metering
pump

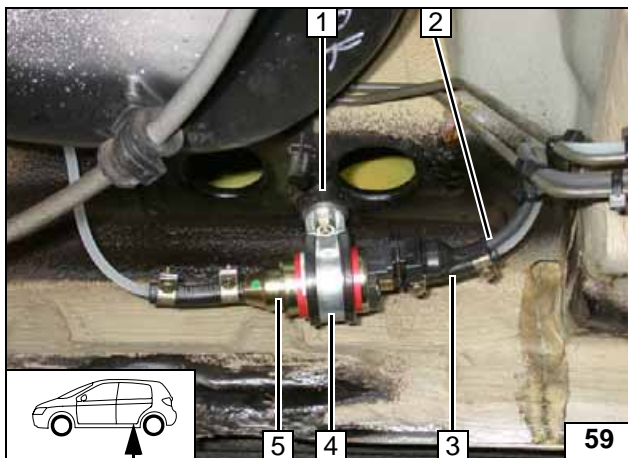

1 Silent block on rivet nut
2 Wiring harness of metering pump, connector mounted
3 Hose section, 10 mm dia. clamp [2x]
4 Rubber-coated p-clamp, flanged nut
5 Metering pump



Installing
metering
pump

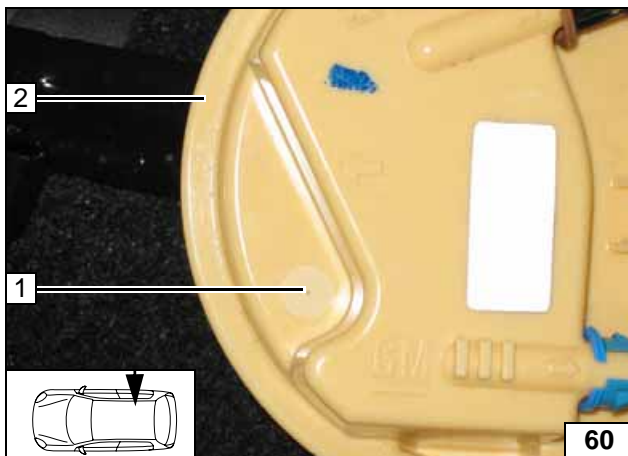

Remove upper section of fuel-tank sending unit **2** in accordance with manufacturer's specifications.

1 Drill 6 mm dia. hole in centering device **1**



Hole
pattern

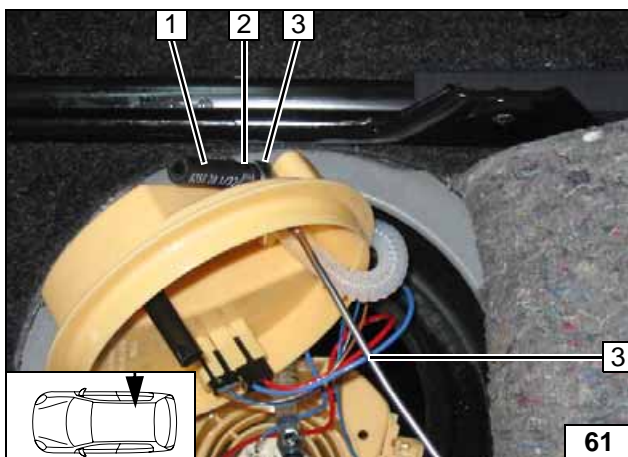

Shape fuel standpipe **3** in accordance with template, cut to length and mount, see "Installation instructions" (alignment as shown).

1 Hose section
2 10 mm dia. Caillau clamp



Installing
fuel
standpipe

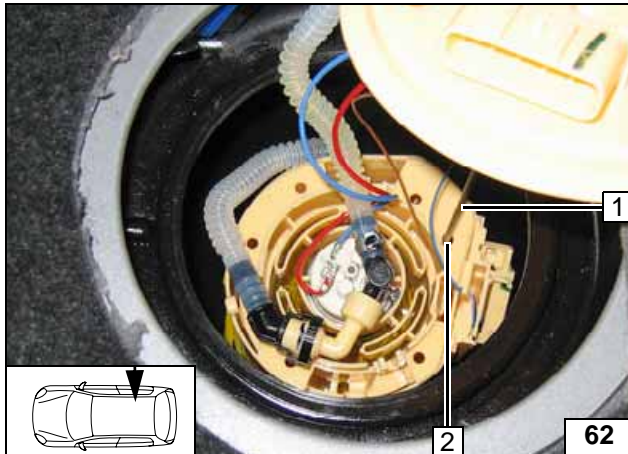

1.3 D

Guide fuel standpipe **1** into existing hole **2** in lower section of fuel-tank sending unit.

1.7 D

No hole present in lower section of fuel-tank sending unit. Position fuel standpipe **1** next to outer edge of swirl pot.



Installing fuel-tank sending unit

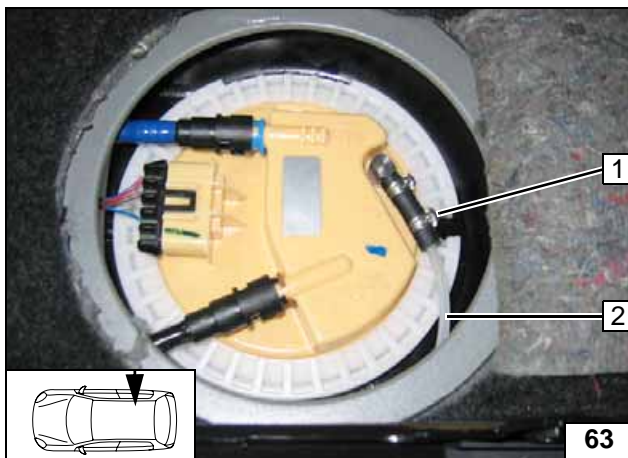

Install fuel-tank sending unit according to manufacturer's specifications. Use new clamp for fuel-tank sending unit (Opel Catalog No: 5815084).

- 1** 10 mm dia. Caillau clamp
- 2** Fuel line



Connect- ing fuel line

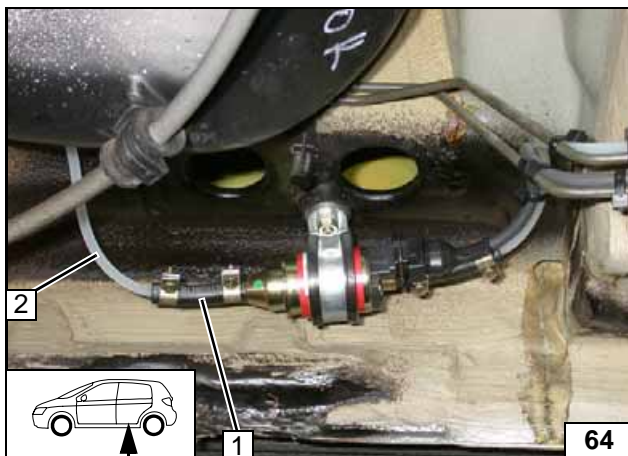

Check the position of the components; adjust if necessary. Check that they have free clearance.

- 1** Hose section, 10 mm dia. clamp [2x]
- 2** Fuel line



Connect- ing meter- ing pump

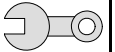

Final Work

WARNING!

Reassemble the disassembled components in reverse order.

Check all hoses, clamps and all electrical connections for firm seating.

Secure all loose cables using cable ties.

Only use manufacturer-approved coolant.

Spray the heater unit components with anti-corrosion wax (Tectyl 100K, Order No. 111329).

- Connect the battery
- Fill and bleed the coolant circuit according to the vehicle manufacturer's specifications.
- Set the digital timer.
- Make settings on A/C control panel according to the "Operating Instructions for End Customer".
- Check the proper operation of the additional heater, see the operating instructions/installation instructions.
- Attach the "Switch off additional heater before refueling" sticker to the left-hand B-pillar.



Webasto AG
Postfach 80 - 82132 Stockdorf
Hotline 01805 / 932278 - Hotfax 0395 / 5592-353
<http://www.webasto.de>

Template for Fuel Standpipe

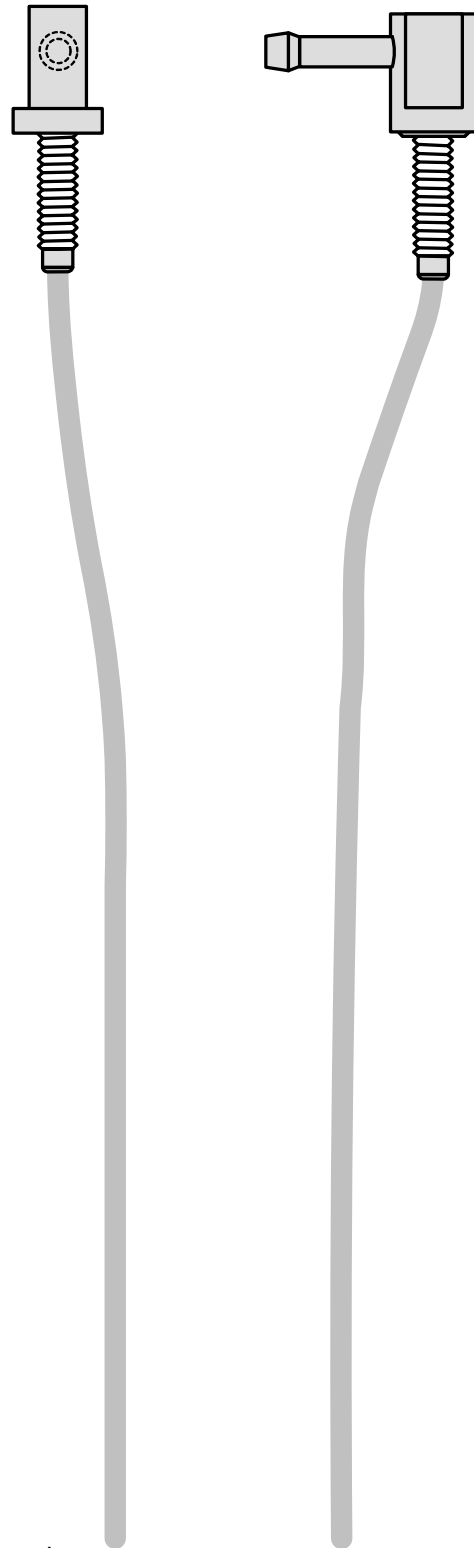

100 mm



Scale 1:1

Compare the size of the printed version with dimension lines.
Permitted tolerance a maximum of 2%.

Set the printer settings to "no margin" or "minimize margins" and 100% of the normal size.

100 mm

0

Operating Instructions for End Customer



Please remove page and add to the vehicle operating instructions.

Note:

We recommend matching the heating time to the driving time.

Heating time = driving time

Example:

For a driving time of approx. 20 min. (in one direction), we recommend not exceeding a switch-on time of 20 min.

If the summer/winter switch option has been installed, this must be switched in accordance with the time of year. The heater unit will then only switch on the vehicle fan to ventilate the vehicle interior in the position Winter heat and in the position Summer .



Before parking the vehicle, make the following settings:

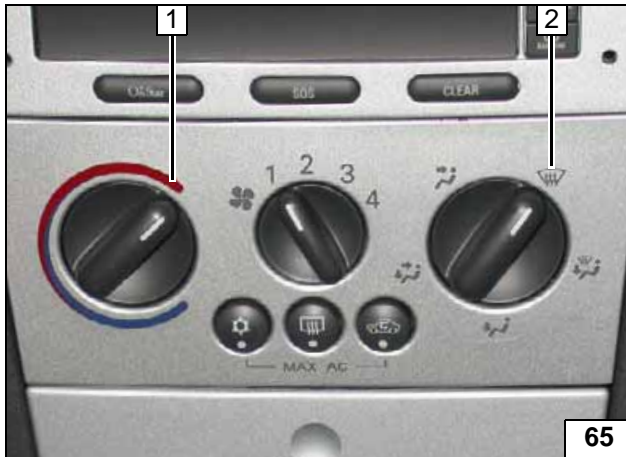

- 1 Set temperature to "max."
- 2 Air outlet to windshield

Manual air-conditioning



- 1 Set temperature to "max."

Automatic air-conditioning