

Legend:

- 1 Combustion air intake silencer
- 2 Thermo Top C/E heater unit
- 3 Blade-type fuse holder
- 4 Exhaust silencer
- 5 Time switch
- 6 Metering pump

Skoda Octavia II

Skoda Octavia II
Combi

Installation

Water Heater Unit

Thermo Top C Auxiliary
Heating



Gasoline - from Model 2005 - left-hand drive only
1.4 MPI and 1.6 FSI

Order number:

BHW 609004A, BHW 609004B
(YHW 609004A, YHW 609004B)

Date: 25.07.2006 / Ident Np.: 9015671A

Table of Contents

Validity	2	Fuel connection	19
Heater Unit / Installation Kit	3	Assembling metering pump	19
Foreword	3	Fuel take-off	20
Special tools	3	Water connection 1.4MPI	22
Explanatory Notes on the Document	4	Water connection 1.6FSI	26
Preliminary Work	5	Exhaust end section	30
Heater Unit Installation Location	5	Underride protection	30
Connection of electrics	6	Fog lamp orifice	31
Assembly of fuse holder and relay K3	7	Final Work	31
Golf blower control without Climatronic	8	Adaptation of the passenger compartment	31
Golf blower control without Climatronic	10	monitoring	31
Time switch option	13	Operating Instructions for the End Customer	32
Summer / winter switch option	13		
Remote Start Option	14		
Pre-assembling the Heater Unit	15		
Pre-assembling exhaust system	16		
Preparing heater unit installation location	17		
Assembling the Heater Unit	17		
Heater unit cable harness	18		

Validity

Manufacturer	Model	Type	EG-BE No. / ABE
Skoda	Octavia	1Z	e11 * 2001 / 116 * 0230...

Engine type	Engine type	Power in kW	Engine capacity in cm ³
BCA	Gasoline	55	1390
BLF	Gasoline	85	1595

Vehicle and engine types, equipment variants as well as national specifications, which are not listed in these installation instructions, have not been tested. Installation according to these installation instructions may, however, be possible.

The installation location of a time switch and summer / winter switch should be confirmed with the end customer before installation.

Heater Unit / Installation Kit

Amount	Description	Order no.:
1	LU Thermo Top C-B for vehicle without air conditioning or with Climatic	9015612A
	Skoda Order No.:	BHW 609004A
		YHW 609004A
or		
1	LU Thermo Top C-B for vehicle with Climatronic	9015613A
	Skoda Order No.:	BHW 609004B
		YHW 609004B

Additional required parts:

Amount	Description	Order no.:
1	3-period time switch	130444B
	Skoda Order No.:	BHW 000 001
		YHW 000 001
and / or		
1	Remote start T90	9014428A
	Skoda Order No.:	BHW 000 002 A
		YHW 000 001



Foreword

These installation instructions apply to Skoda Octavia vehicles with 1.4 MPI and 1.6 FSI- engines - for validity, see page 2 - from model year 2004 and later, assuming technical modifications to the vehicle do not affect installation, any liability claims excluded. Depending on the vehicle version and equipment, modifications may be necessary during installation with respect to these installation instructions.

However, the stipulations in the "installation instructions" and "operating and maintenance instructions" for the *Thermo Top C/P/E* are to be observed in any event.

The corresponding rules of technology and any information from the vehicle manufacturer should be observed during the installation work.

Special tools

- Torque spanner for 2.0 - 10 Nm
- Vise-grip wrench

Explanatory Notes on the Document

To provide you with a quick overview of the individual working steps, you will find an identification mark on the outside top right corner of the page in question.

Mechanical work

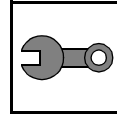

Electrical connection

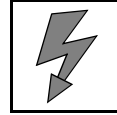

Water connection

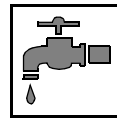

Fuel connection

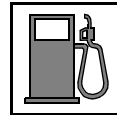

Exhaust system

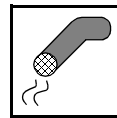

Combustion air

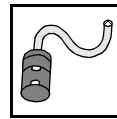

Special features are highlighted using the following symbols:



Specific risk of injury or fatal accidents.



Specific risk of damage to components.



Specific risk of fire or explosion.



Reference to general installation instructions of Webasto components or to the manufacturer's vehicle-specific documents.



Reference to a special technical feature.

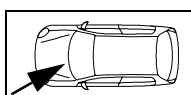
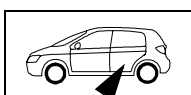

The arrow in the vehicle icon indicates the position on the vehicle and the viewing angle.

Preliminary Work

WARNING!

- Open the tank cap, ventilate the tank.
- Close the tank cap again.
- Pressure in the cooling system!
- Copy the factory number from the original type label to the duplicate type label.
- Remove years that do not apply from the duplicate label.
- Attach the duplicate label (type label) in the appropriate place.
- Disconnect the battery.
- Remove the battery.
- Remove the battery holder.
- Remove the engine cover.
- Remove the front left wheel.
- Remove the front left section of the wheel-house panel.
- Remove left mist lamp or, for vehicle without mist lamp. remove left cover.
- Remove left headlight (only with remote start)
- Remove the underride protection
- Remove right underbody cover.
- Remove the rear seat bench.
- Open right tank mounting service lid.
- Remove the footwell panel on the driver's side
- Remove the lower dashboard panel on the driver's side
- Only for vehicles with Climatronic: Remove the footwell panel on the passenger's side

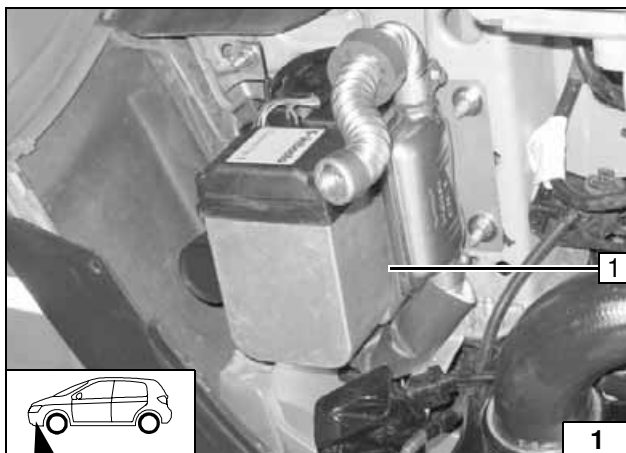

Heater Unit Installation Location

The installation location is in front of the left front wheel.

- 1 Heater unit



Installation location



Electrical Connections



Fuse holder

- 1 Fuse holder (assembly, page 7)
- 2 Route the cables for the controls, blower control and metering pump in the cable channel to the bulkhead

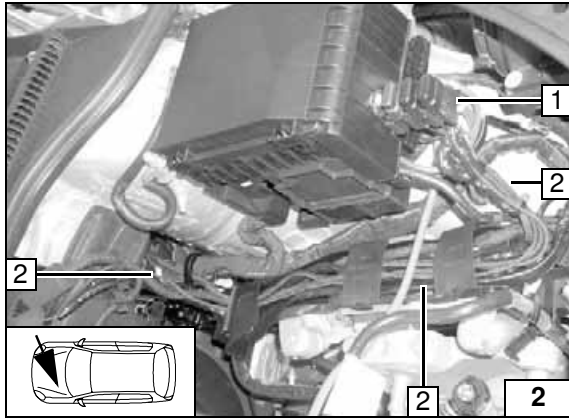

Installation of cables

- 1 Metering pump cable harness together with fuel line in water channel (assembly, page 19)

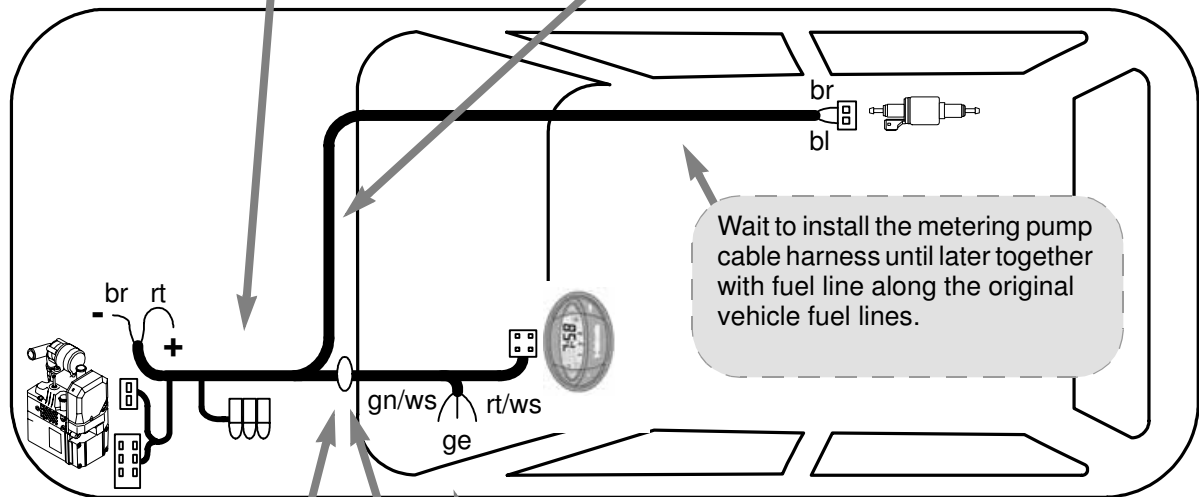
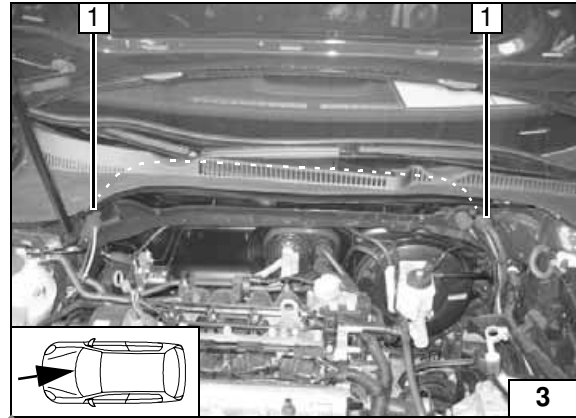

Cable harness routing diagram, all models

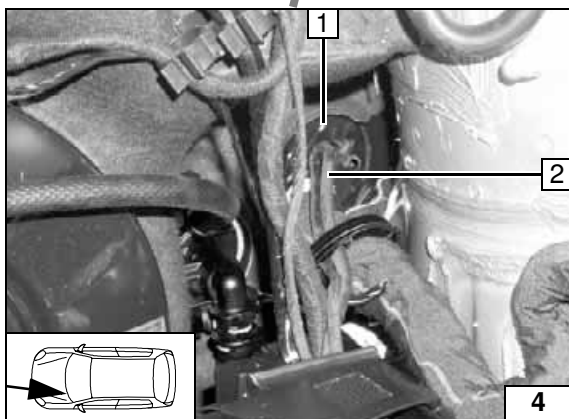

Cable harness feed-through

- 1 Original vehicle cable harness feed-through
- 2 Blower control and control cable harness (blower connection, pages 8-12; control connection, page 13)

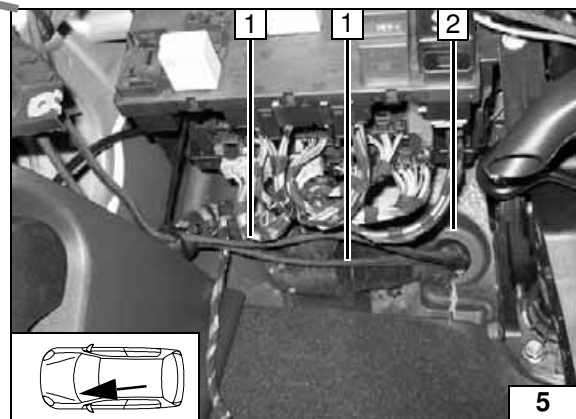

Cable harness feed-through

- 2 Original vehicle cable harness feed-through
- 1 Blower control and control cable harness

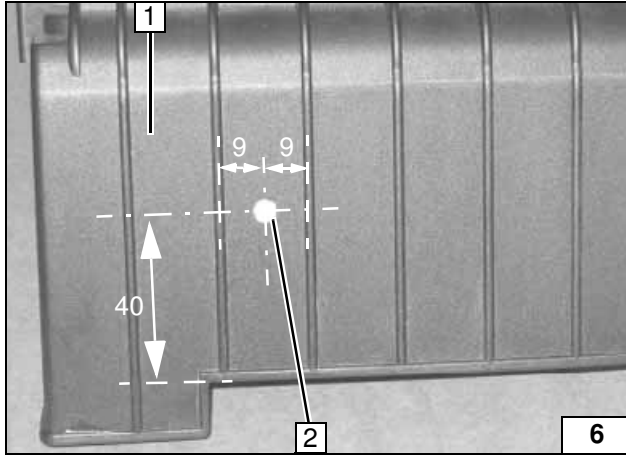

Fuse holder assembly

Countersink hole **2** from the rear for M5 countersunk screws!

- 1** Cover for fuse/relay holder in the engine compartment
- 2** Hole Ø 5.0 mm



Hole for fuse holder

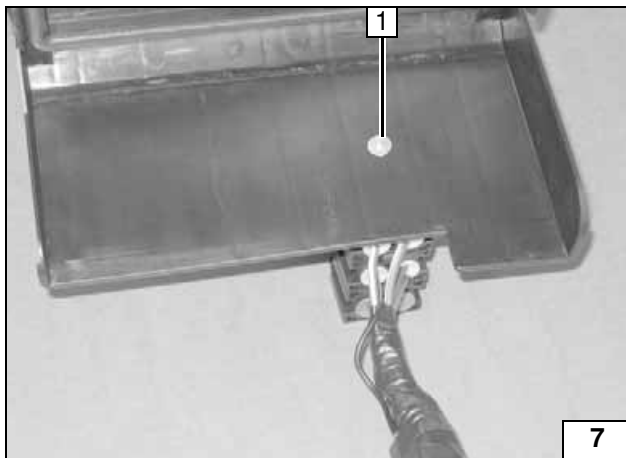

- 1** Countersunk screw M5x10

Fuse holder assembly

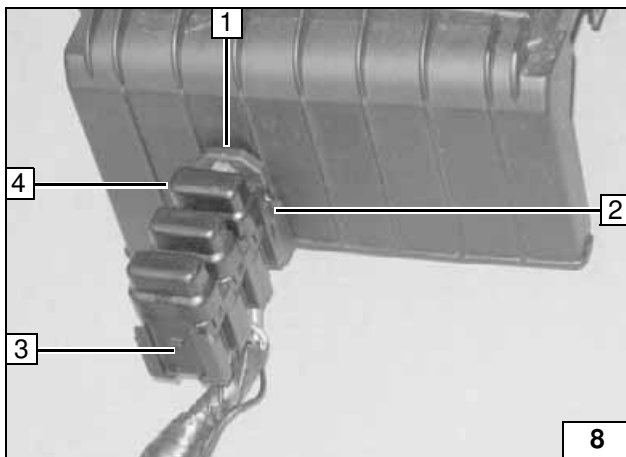

For vehicle with Climatronic, remove fuse F3 25A **4!**

- 1** Upholstery washer (between cover and retaining plate), M5 locknut
- 2** Retaining plate
- 3** Fuse holder



Fuse holder assembly

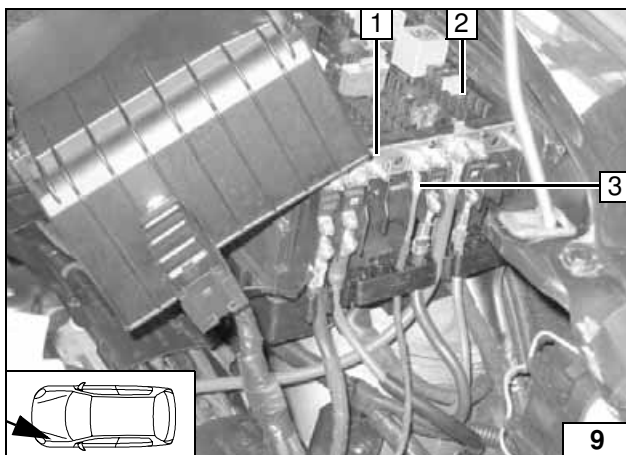

Route and connect the ground cable br to the vehicle grounding point below headlight!

- 2** Fuse/Relay holder
- 3** Positive lead rt
- 1** Positive terminal



Positive and ground wire connection

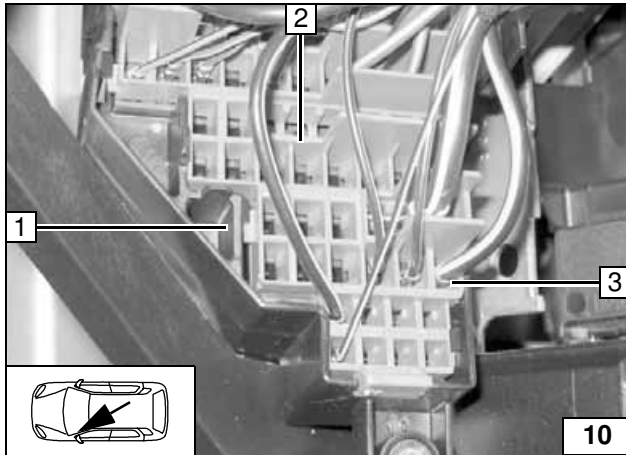

Blower control without Climatronic

Release vehicle fuse holder **1** [instrument panel above left] and unbolt circuit breaker **2**. Uncrimp wire sw/bl 4mm² **3** from circuit breaker terminal SC40.



Uncrimp wire

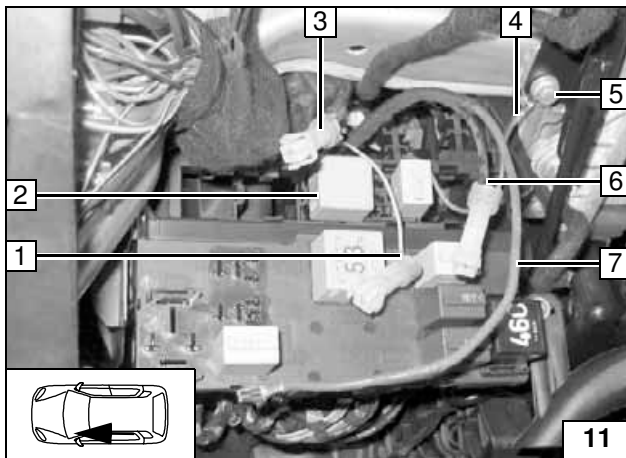

Location of the free slot depends on the vehicle equipment!

- 2** Relay K3
- 4** Cable br from K3/85
- 5** Original vehicle bolt
- 3** Cable rt/ws to K3/87
- 6** Black (sw) cable from K3/30
- 7** Cable (rt) to K3/87a
- 1** Cable gn/ws to K3/86



Fit cable harness for vehicle without Climatronic

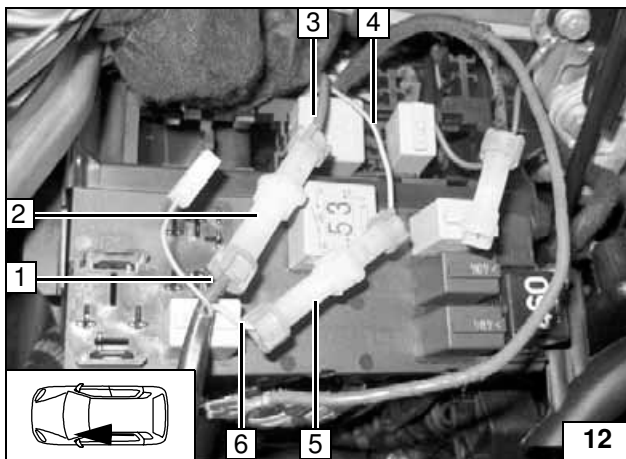

Reconnect according to the circuit diagram.

- 1** Cable rt/ws to Fuse F3
- 2** AMP housing
- 3** Cable rt/ws 11/3 to K3/87
- 6** Cable gn/ws from heater socket X1/4
- 5** AMP housing
- 4** Cable rt/ws 11/1 to K3/86

Connect cables to heating wiring harness

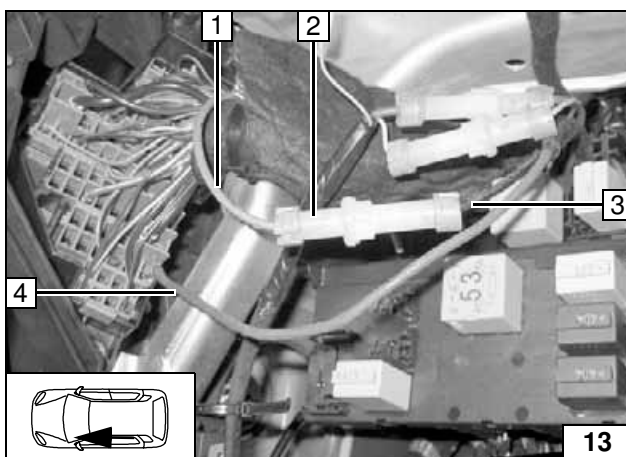

Reconnect according to the circuit diagram.

- 1** Cable sw/bl **10/3** with original standard power timer
- 2** AMP housing
- 3** Cable sw **11/6** from K3/30
- 4** Cable rt **11/7** from K3/87a inserted into fuse terminal SC40

Connect cables to vehicle cable harness

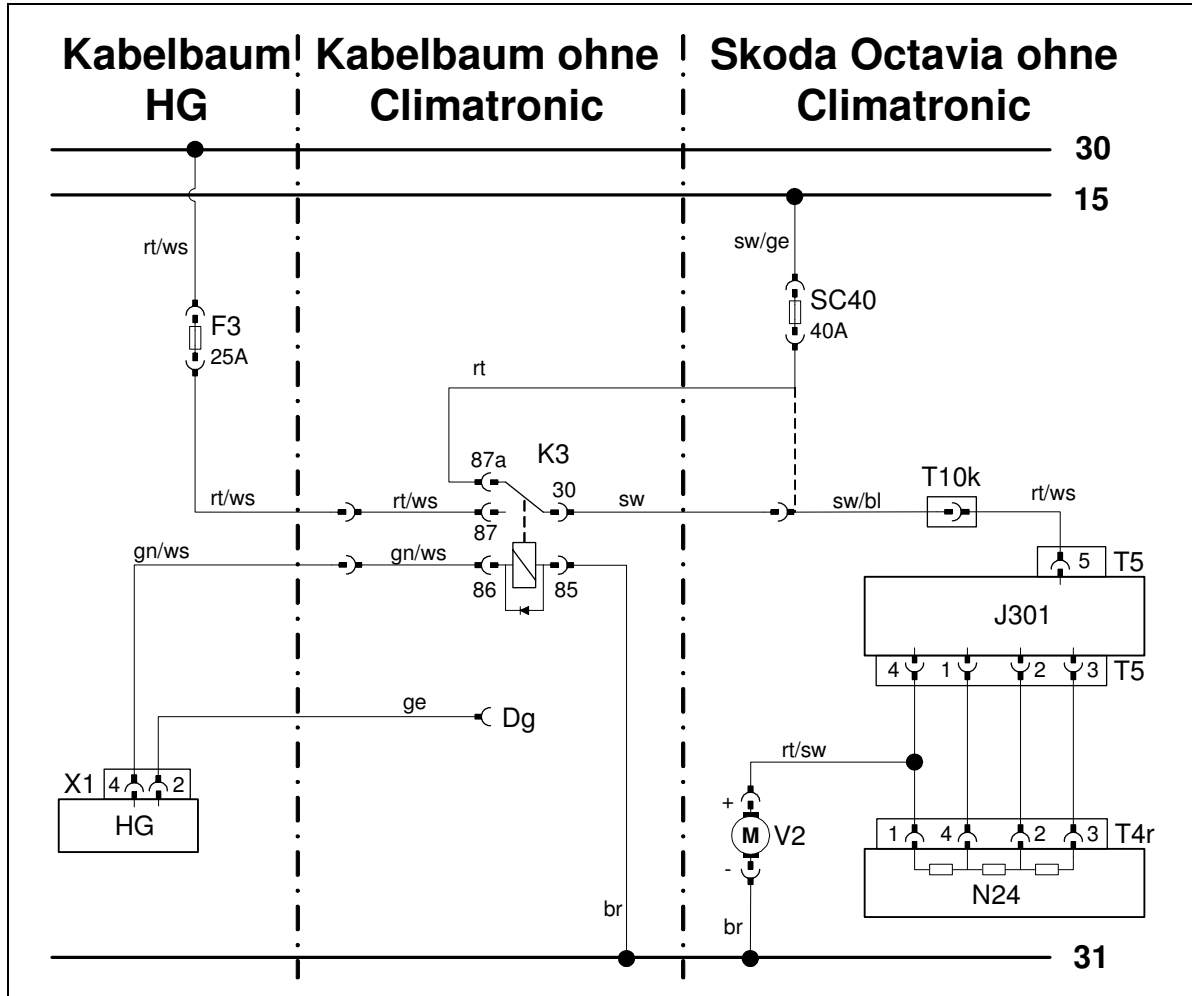

Circuit diagram without Climatronic

Original equipment component		Vehicle components		Colors and symbols	
HG	Heater unit TT-C/E	SC40	Blower fuse	rt	red
X1	6-pin heater unit connector	J301	Air conditioning controller	ws	white
F3	Fuse	N24	Resistor group	sw	black
K3	Blower relay	V2	Blower motor	br	brown
Dg	Diagnostic connection	T...	Terminal	gn	green
				ge	yellow
				bl	blue

Legend without Climatronic

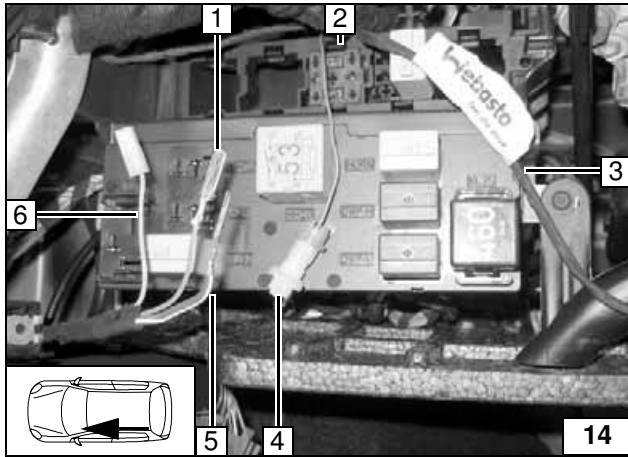

Blower control with Climatronic

Location of the free slot depends on the vehicle equipment!

- 1 Cable gn/ws from heater socket X1/4
- 5 Cable rt/ws from Fuse holder F3
- 6 Diagnostic cable ge
- 2 Socket for IPCU module
- 3 Cable harness with cables rt from IPCU/E and sw/ws from IPCU/A
- 4 Cable gn/ws from K3/86



Assembling the cable harness

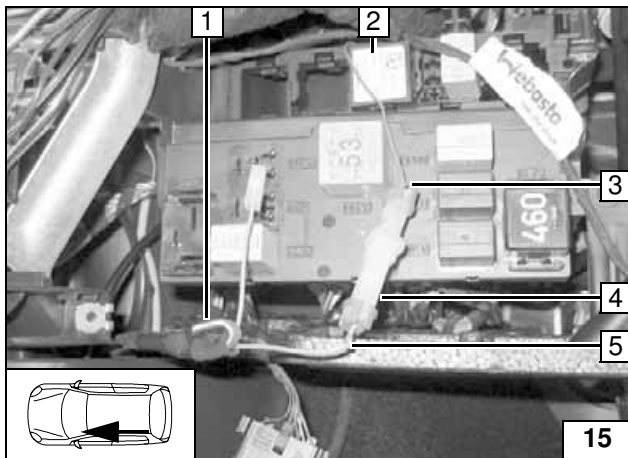

Reconnect cables according to schematic, isolate and tie back cable rt/ws 1 from fuse holder F3!

- 2 IPCU module
- 3 Cable gn/ws 14/4 from IPCU/86
- 5 Cable gn/ws 14/1 from Hg X1/4
- 4 AMP housing



Connect cables

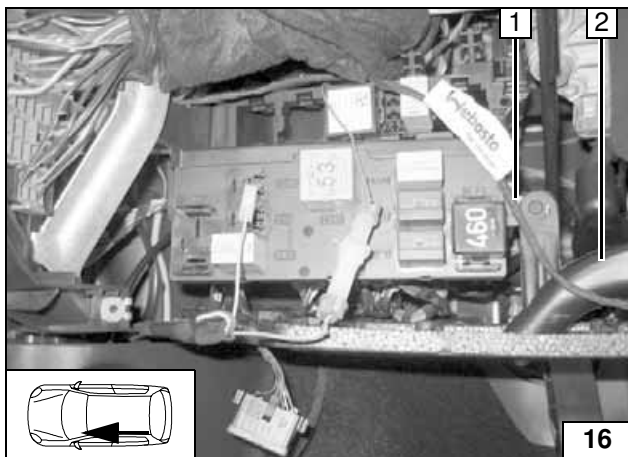

Connect cable br from IPCU/85 to vehicle earth point (under A pillar)

Route cable harness from IPCU Module 1 (cables rt from IPCU/E and sw/ws from IPCU/A) along air hose 2 to center console



Route cable harness from IPCU Module

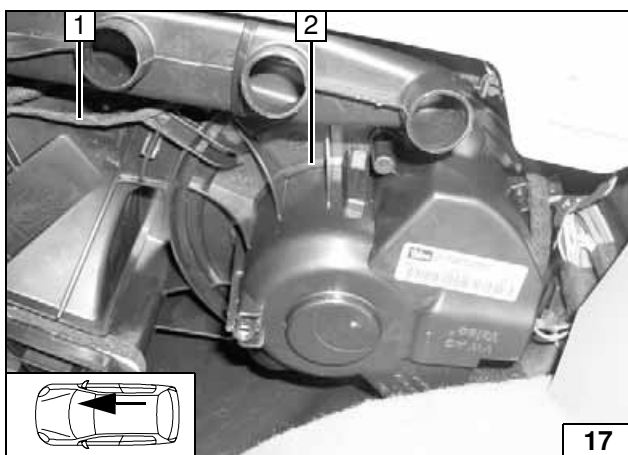

Route cable harness from IPCU Module 1 (cables rt from IPCU/E and sw/ws from IPCU/A) along original vehicle cable to blower unit 2



Remove blower unit

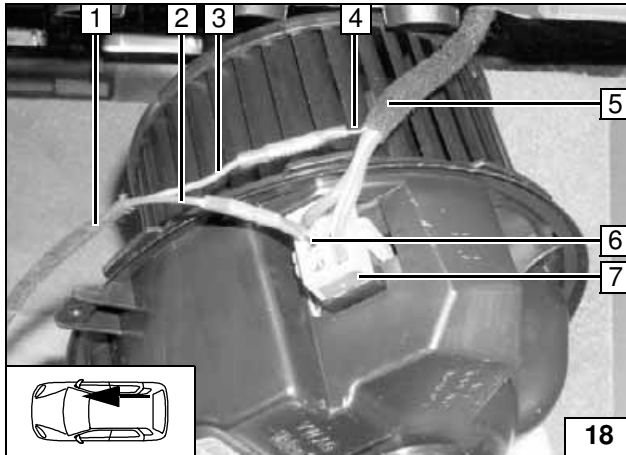

Remove blower unit
 Disconnect cable sw/ws 4, 6 from socket T6t/2
 Reconnect according to schematic using push connectors (crimp and sleeve)

- 1 Cable harness from IPCU
- 2 Cable sw/ws from IPCU/A
- 6 Cable sw/ws to socket T6t/2
- 3 Cable sw/ws from IPCU/E
- 4 Cable sw/ws from Climatronic-Sg
- 5 Vehicle cable harness
- 7 Connector T6t



Connect cables

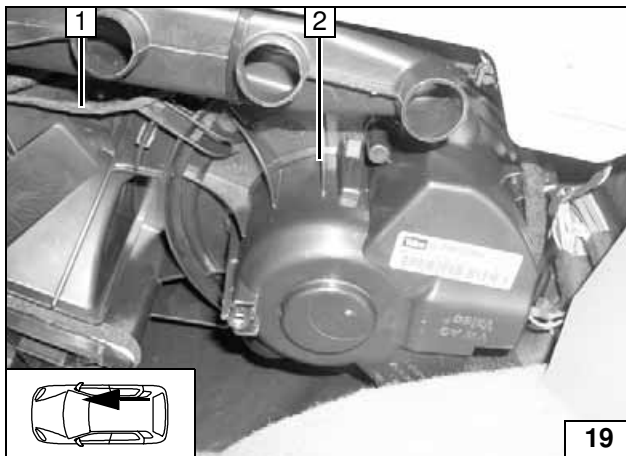

Refit blower unit
 Secure cable harness to vehicle cables with tie-wrap

- 1 Cable harness from IPCU
- 2 Blower unit



Refit blower unit

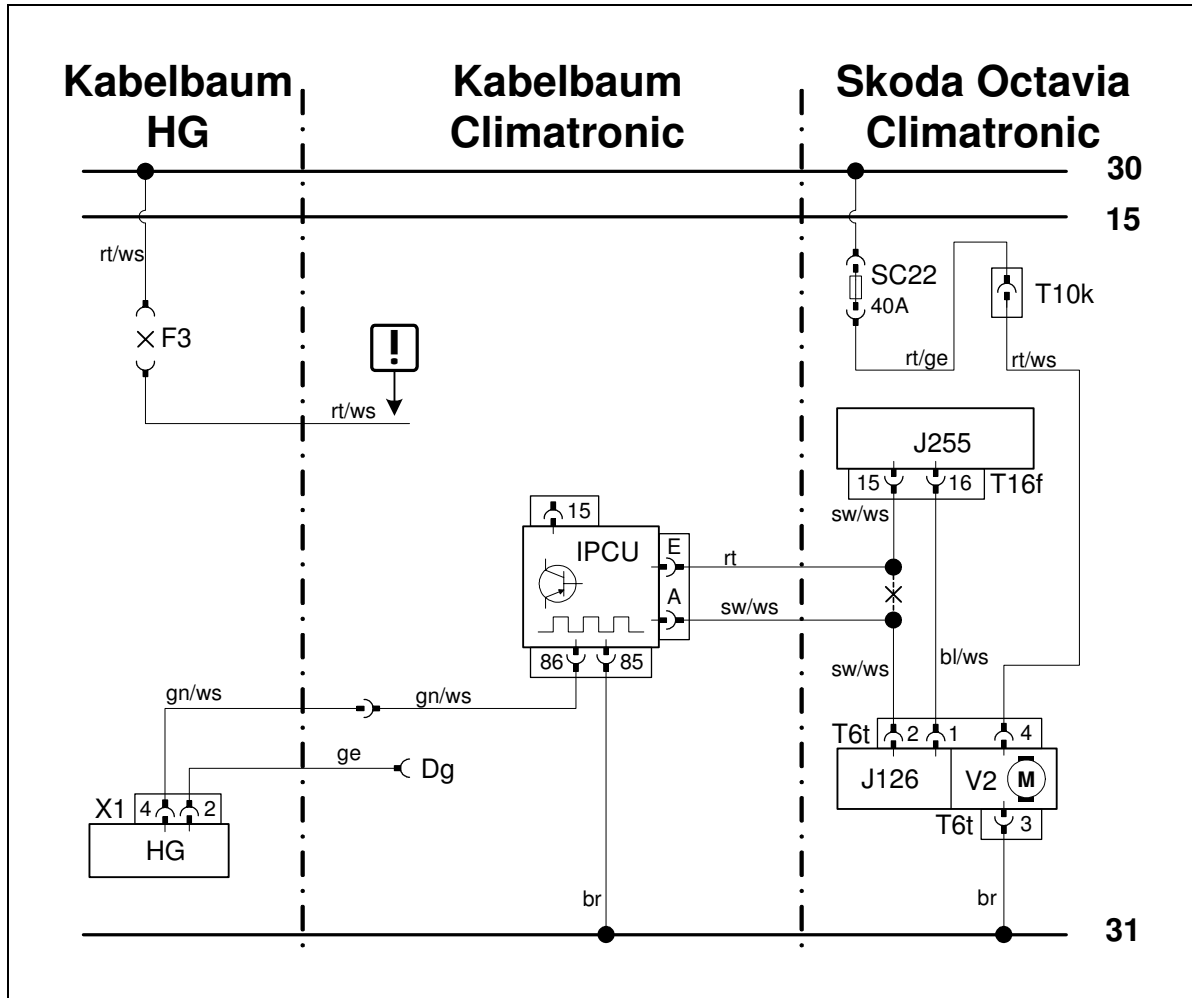

Schematic with Climatronic

Original equipment component		Vehicle components		Colors and symbols	
HG	Heater unit TT-C/E	SC22	Blower fuse	rt	red
X1	6-pin heater unit connector	J255	Climatronic control	ws	white
F3	Fuse removed	V2	Blower motor	sw	black
Dg	Diagnostic connection	J126	Blower control	br	brown
IPCU	Intelligent pulse control unit			gn	green
				! (in box)	yellow
				bl	blue
					Insulate and tie back wire ends
				X	Splitting point

Legend with Climatronic

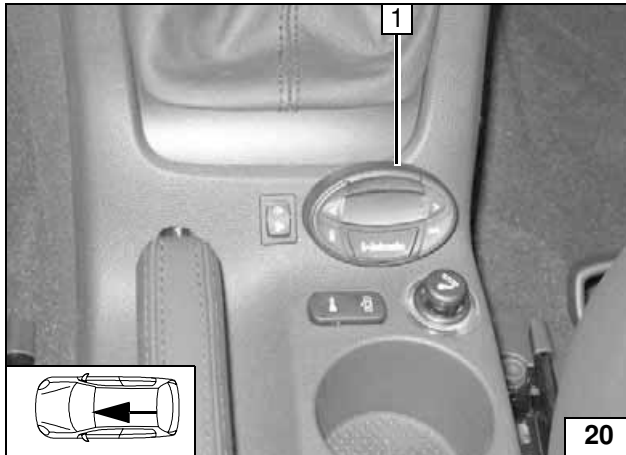

Time switch

Do not push on the display

1 Timer, drilling template



Timer
option

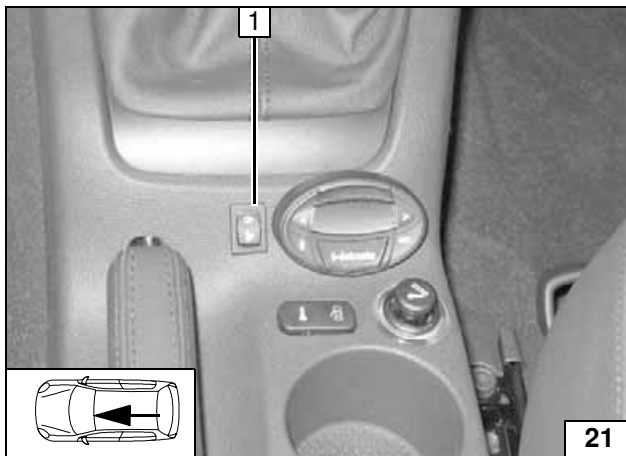

1 Summer/Winter switch; hole Ø 12.0 mm



Summer/
winter
switch
option

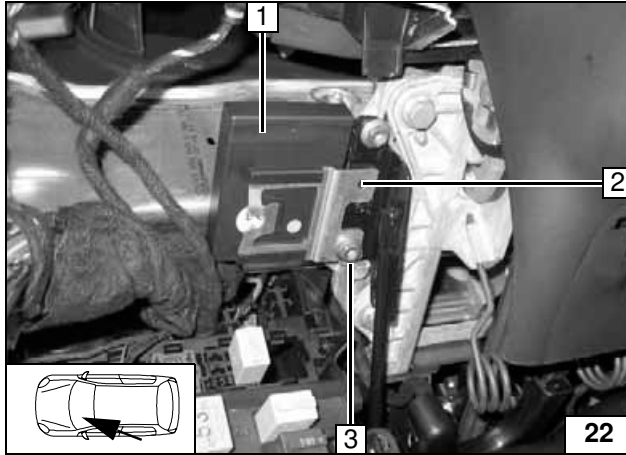

Remote Start Option

If bolt M6 **3** is not available, use a suitable M6 bolt with spring washer!

- 2** Holder, lower hole drilled out to \varnothing 6.5 mm
- 1** Receiver
- 3** Screw M6

Assembling the receiver

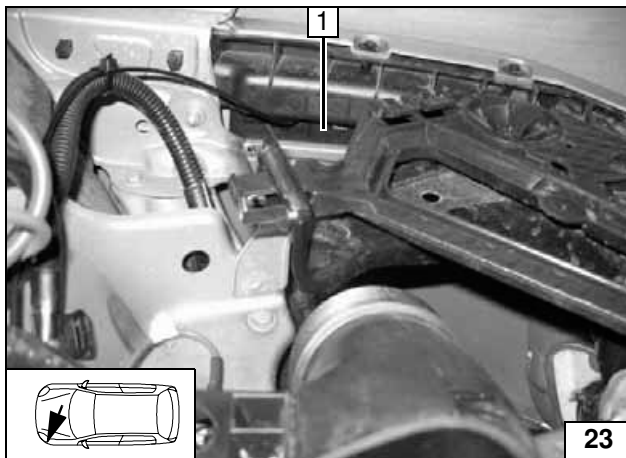

Attach antenna **1** to shock damper inside left-hand side!

Assembling the antenna

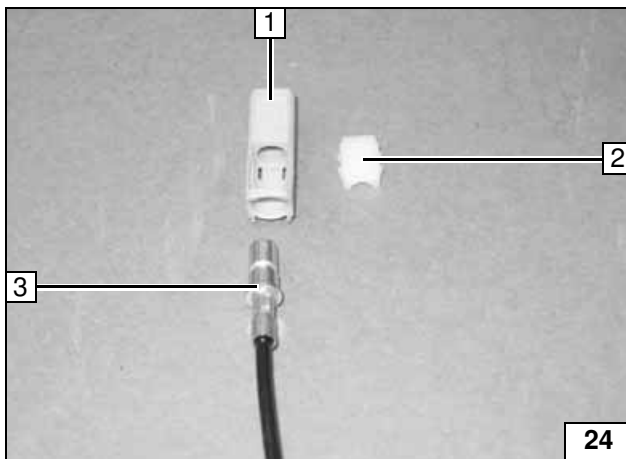

- 2** Remove mounting plate
- 1** Remove housing
- 3** Antenna cable

Dismantle antenna connector

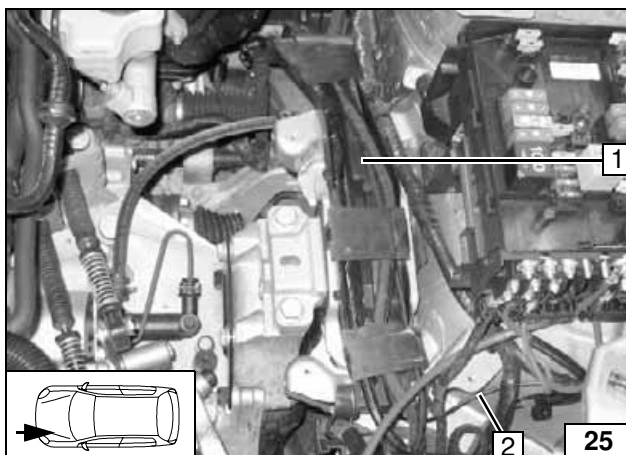

Route antenna cable **2** through cable channel **1** and then through cable feed-through into interior. Reassemble antenna connector and connect to receiver!

Route antenna cable

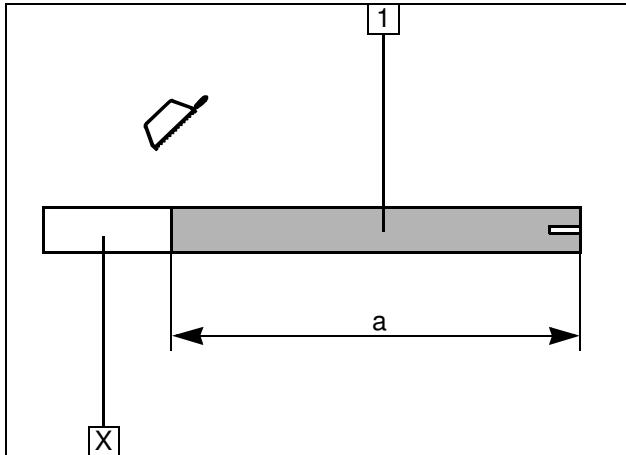
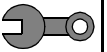

Preassemble the Heater Unit

- 1 Combustion air pipe
a = 250 mm

Dispose of section X

Cutting the combustion air pipe to length

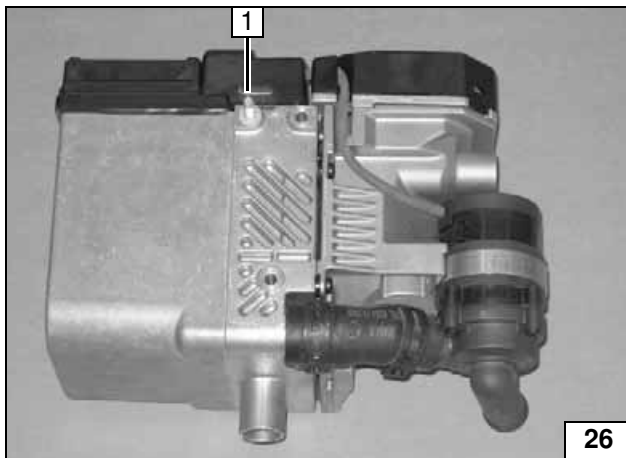

Eجت stay bolts, tightening torque 10 Nm.

- 1 Eجت stay bolts

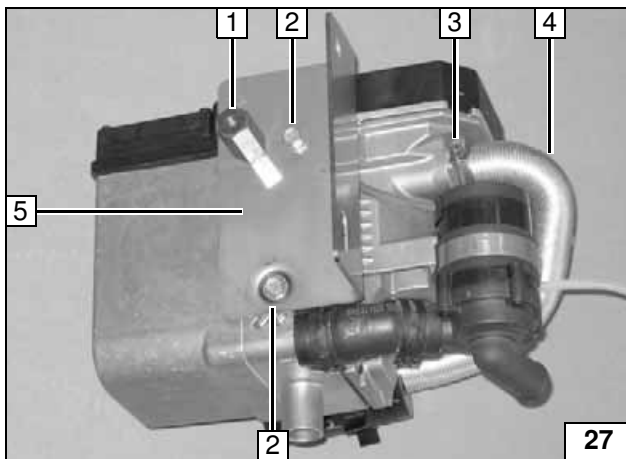

Eجت screw bolts tightening torque 10 Nm!

- 5 Bracket
- 2 Washer, eجت screw bolt [2x]
- 1 Spacer nut M6x30
- 4 Pre-prepared combustion air pipe (slotted side to Hg)
- 3 Hose clamp

Pre-assembling the heater unit

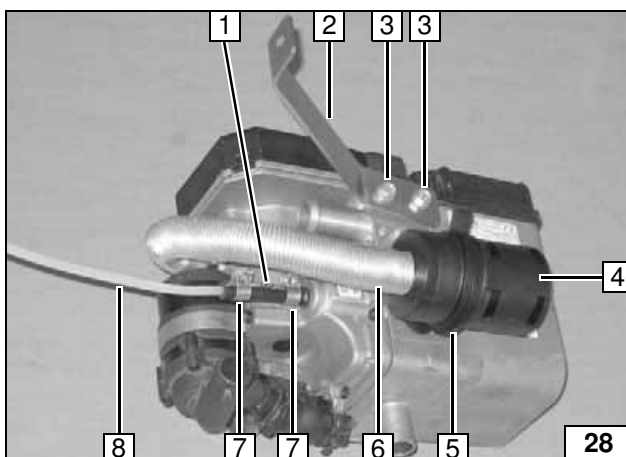

Eجت screw bolts tightening torque 10 Nm!
Note the installation position of the air intake silencer, see the Installation Instructions.

- 2 Strut
- 3 Eجت screw bolt [2x]
- 5 Mounting clip in heater hole
- 4 Combustion air intake silencer
- 6 Combustion air pipe
- 8 Fuel line
- 1 Sleeve
- 7 10 mm hose clamps [2x]

Pre-assembling the heater unit



Pre-assemble the Heater Unit

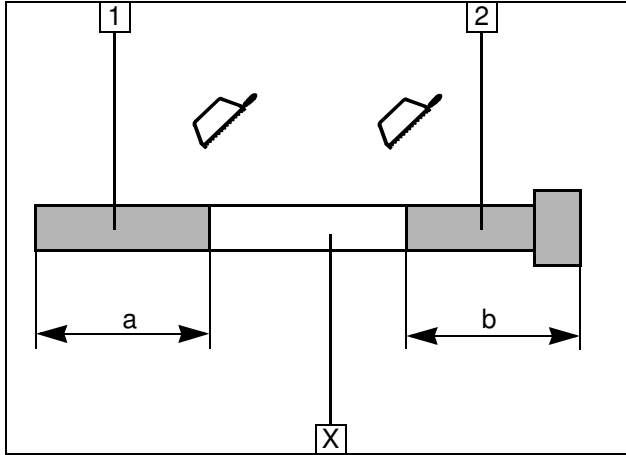
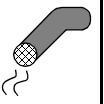

Pre-assemble exhaust system

- 1 Exhaust pipe
a = 190 mm
- 2 Exhaust end section
b = 240 mm

Dispose of section X



Preparing the exhaust pipe

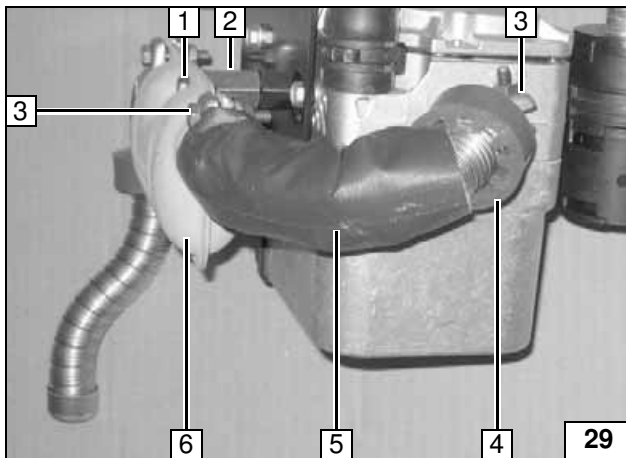

Form exhaust pipe as in Figure 27 and 28 slide on insulation

- 6 Silencer
- 1 M6x16 bolt, spring washer
- 2 Pre-assembled spacer nut M6x30
- 5 Exhaust pipe with insulation
- 4 Rubber profile, red, without groove
- 3 Hose clamp [2x]



Pre-assemble exhaust system

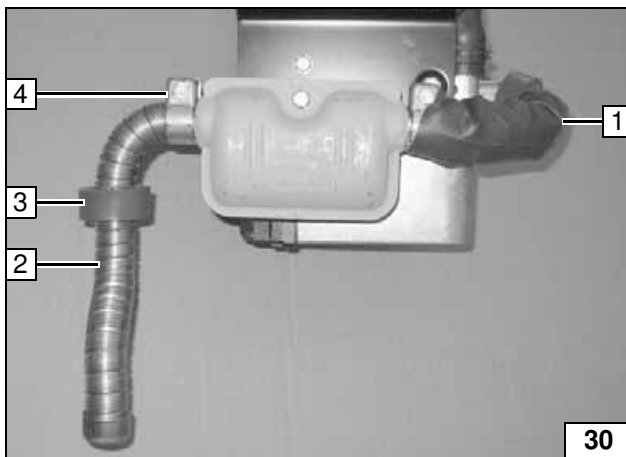

Form exhaust end piece 2 according to figures 28 and 29

- 1 Exhaust pipe
- 4 Hose bracket
- 3 Rubber profile, red, without groove



Pre-assemble exhaust system



- 1 Exhaust end section

Pre-assemble exhaust system

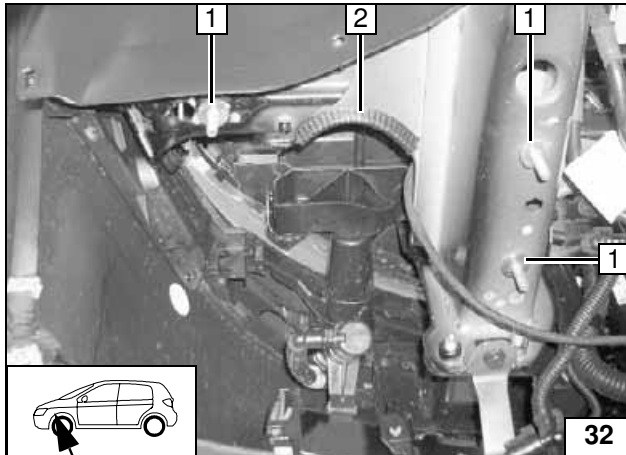
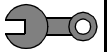

Preparing the installation location

Prevent upholstery washers falling out with adhesive

- 1 Upholstery washer on original vehicle stay bolts [3x]
- 2 Edge protection profile



Inserting edge protection

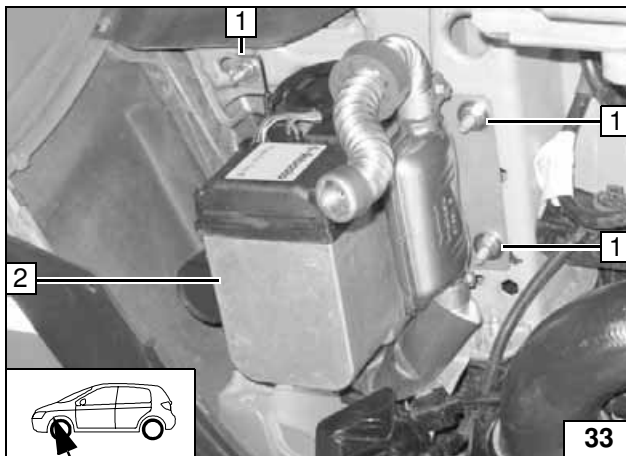

Installing the Heater Unit

- 1 Upholstery washer, locknut M8 [3x]
- 2 Heater unit (pre-assembled)



Assembling the heater unit

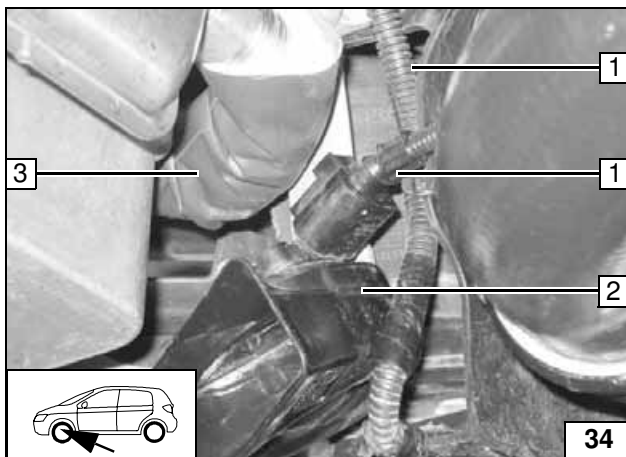

Check the exhaust system clearance with respect to original vehicle components and cables

- 3 Exhaust pipe
- 1 Vehicle cable harness (secured with tie-wraps)
- 2 Horn



Align exhaust system

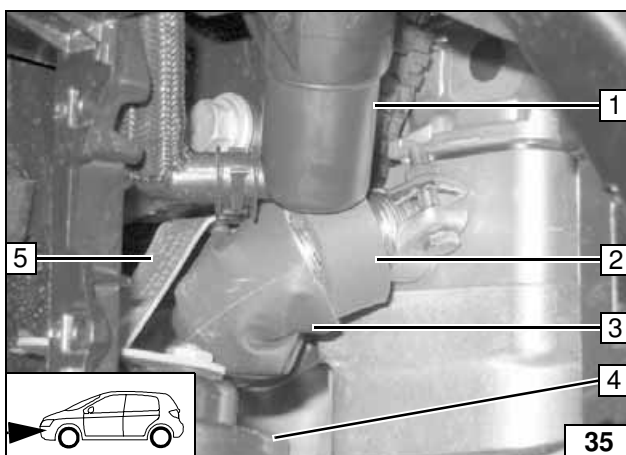

Check the exhaust system clearance with respect to original vehicle components and cables

Position rubber profile according to figure. The illustration shows vehicle with headlight cleaning system.

- 1 Headlight cleaning system
- 2 Rubber profile, red
- 3 Exhaust pipe with insulation
- 4 Horn
- 5 Horn bracket



Align exhaust system

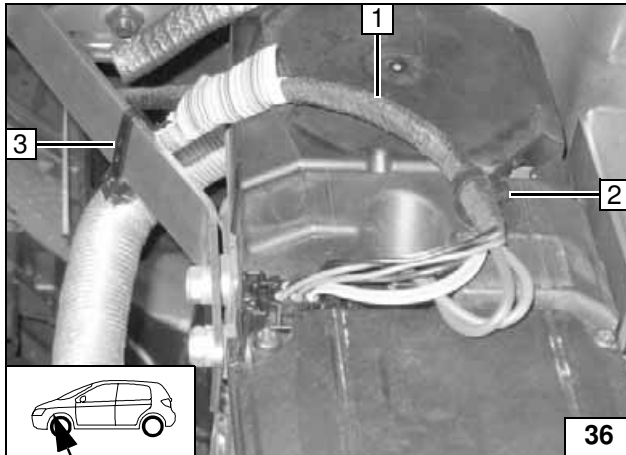

Heater unit cable harness

Pay attention to the cable harness routing
Risk of scuffing!

- 1 Heater unit cable harness
- 2 Clip-on cable clip in pre-pierced hole for the heater unit cover
- 3 Cable tie



Connect and route cable harness

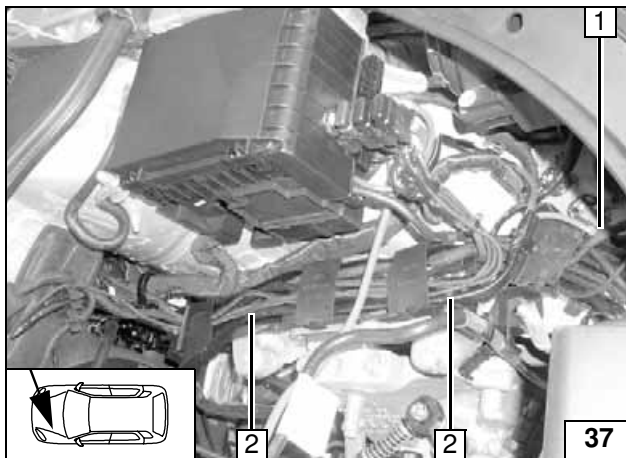

Pay attention to the cable harness routing
Risk of scuffing!

Route surplus heater unit cable harness **1** in the cable channel **2** underneath the battery and secure with tie-wraps!



Routing the cable harness



Fuel connection

CAUTION!

Open the vehicle's tank-cap lock, ventilate the tank and then re-close the tank lock.

Catch any fuel running off with an appropriate container.

Route the fuel line and cable harness so that they are protected against stone impact!

Fit the fuel line and cable harness with edge protectors around sharp edges.

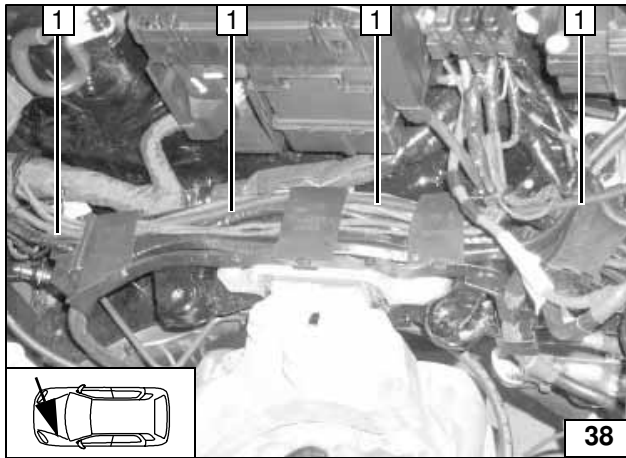

1 Fuel pipe in protective sleeve

Route fuel line to bulkhead

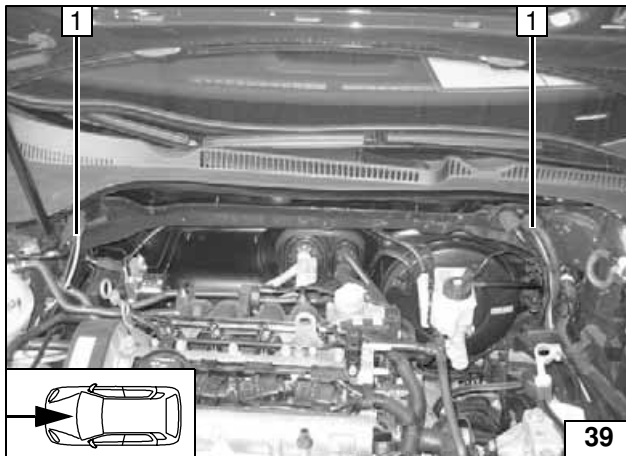

Route metering pump cable harness and fuel line in protective sleeve in water channel to right side of vehicle Cut off protective sleeve at cable feed-throughs 1 Pay special attention to the wiper shaft clearance



Route fuel line and metering pump cable harness

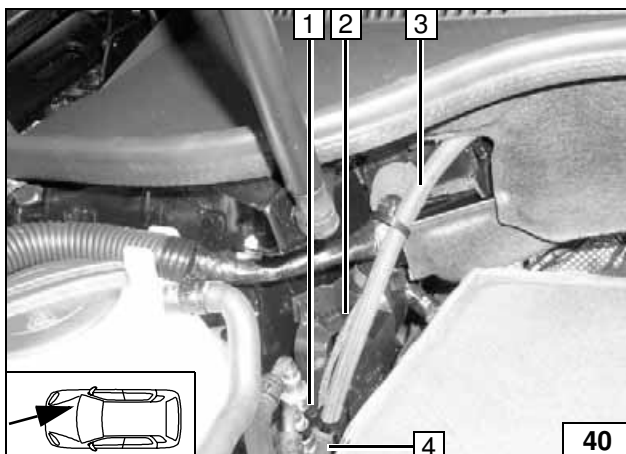

Feed fuel line with protective sleeve 3 and metering pump cable harness 2 through vehicle cable channel 4 Route fuel line together with metering pump cable harness 2 in vehicle cable channel 1, 39/1 to lower floor plate



Route fuel line and metering pump cable harness

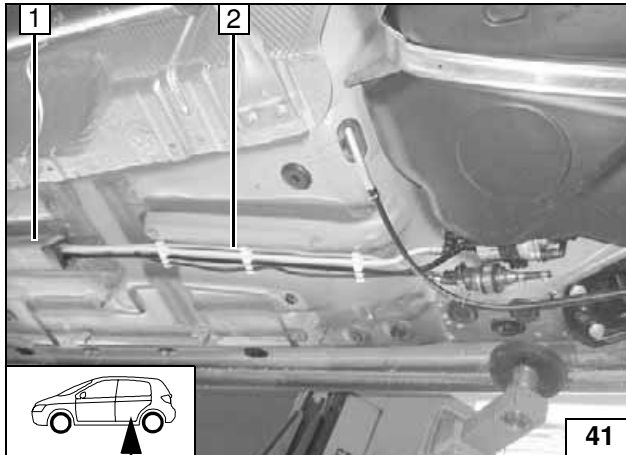

Route fuel line and metering pump cable harness along the original vehicle fuel lines 2 to the tank

1 Cable channel



Route fuel line and metering pump cable harness

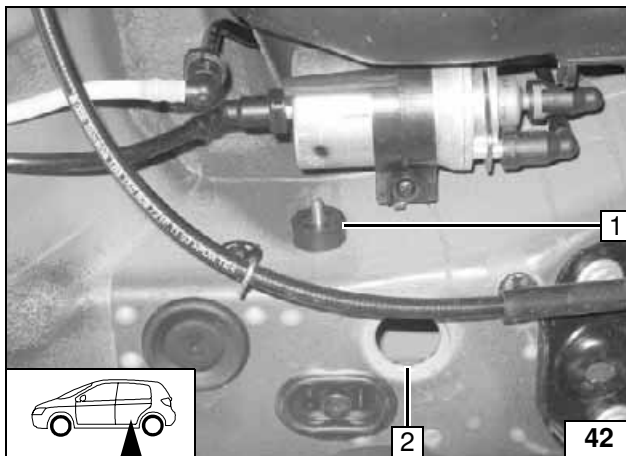

2 Stopper removed

1 Anti-vibration mount, upholstery washer, locknut M6

Fit anti-vibration mount

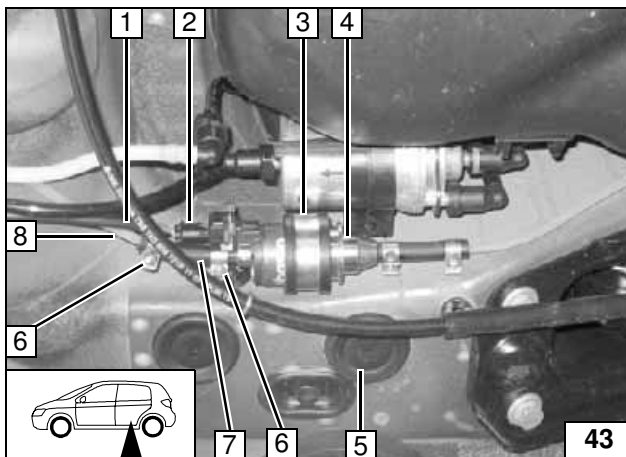

4 Metering pump

3 Rubberized tube clamp with flanged nut fastened to anti-vibration mount

1 Metering pump cable harness

2 Connector housing, single-core gasket, connector contact

8 Fuel line

7 Sleeve

6 Hose clip \varnothing 10 mm [2x]

5 Stoppers refitted



Fit metering pump and connect at pressure side

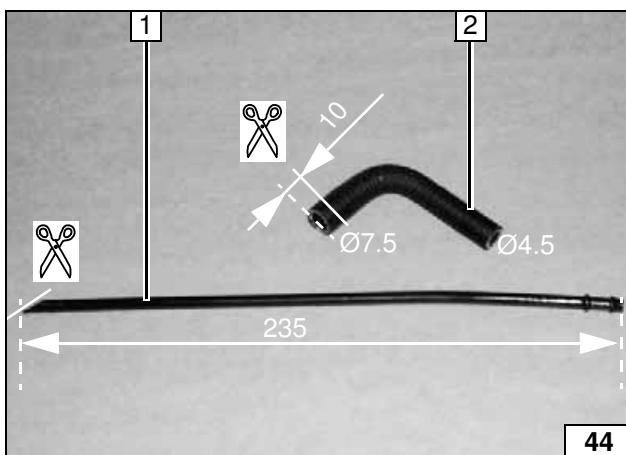

Fuel extraction

1 Ascending pipe

2 Molded hose

Shorten ascending pipe and molded hose

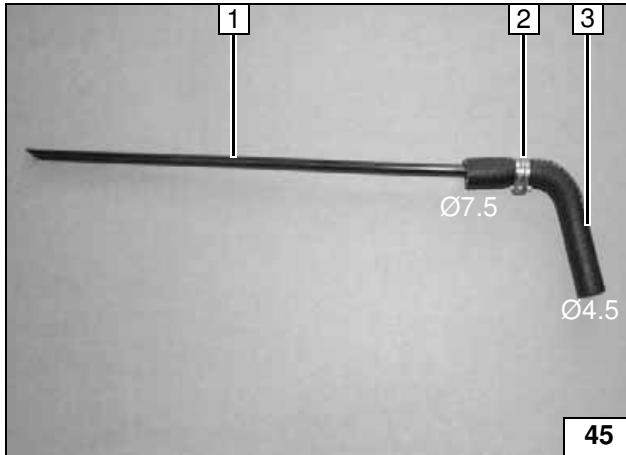

Universal clamp $\text{Ø} 10 \text{ mm}$ **2** halfway along the thickening at the end of the ascending pipe

- 1** Ascending pipe
- 3** Molded hose



Shorten ascending pipe and molded hose

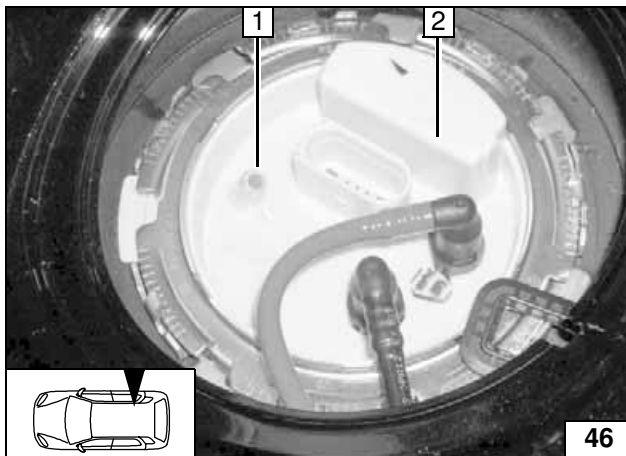

Cut off 3 mm from blind end

- 1** Cut off tip of blind end
- 2** Tank mounting



Cut off blind end

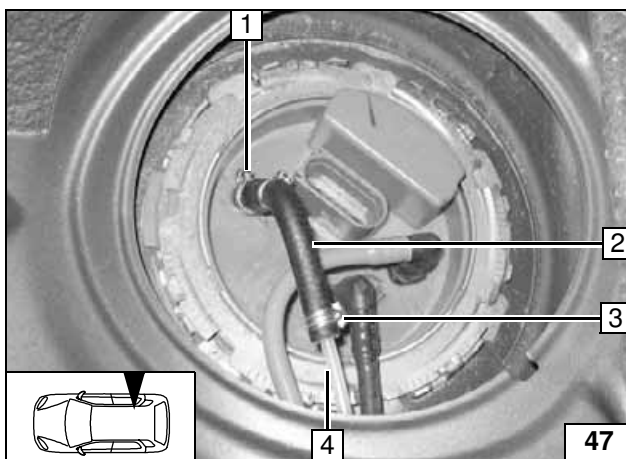

If the ascending pipe is supplied slightly bent, arrange it so that the end points to the rear and to the right. Otherwise there is a risk that the fill indication will be affected

- 1** Universal clamp $\text{Ø} 13.5 \text{ mm}$
- 2** Pre-fitted molded hose with ascending pipe
- 3** Universal clamp $\text{Ø} 10 \text{ mm}$
- 4** Leftover piece of fuel line



Connection to tank mounting

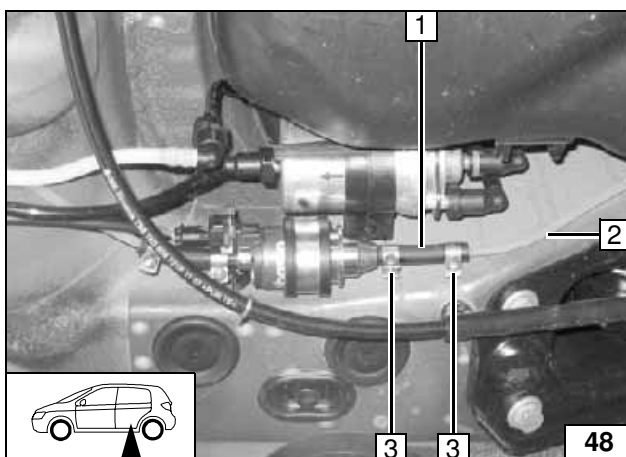

- 2** Fuel line from tank mounting
- 1** Sleeve
- 3** Hose clip $\text{Ø} 10 \text{ mm}$ [2x]



Connecting the metering pump, suction side

Arrange the fuel line and metering pump cable harness together along their lengths and secure with tie-wraps





Water connection 1.4 MPI

WARNING!

Any coolant water running off should be collected using an appropriate container!

Route hoses so that they are kink-free.

Position spring clips and hose clips so that no other hose can be damaged! Tighten all hose clamps to 2.0 +0.5 Nm.

The connection should be "inline" based on the following diagram:

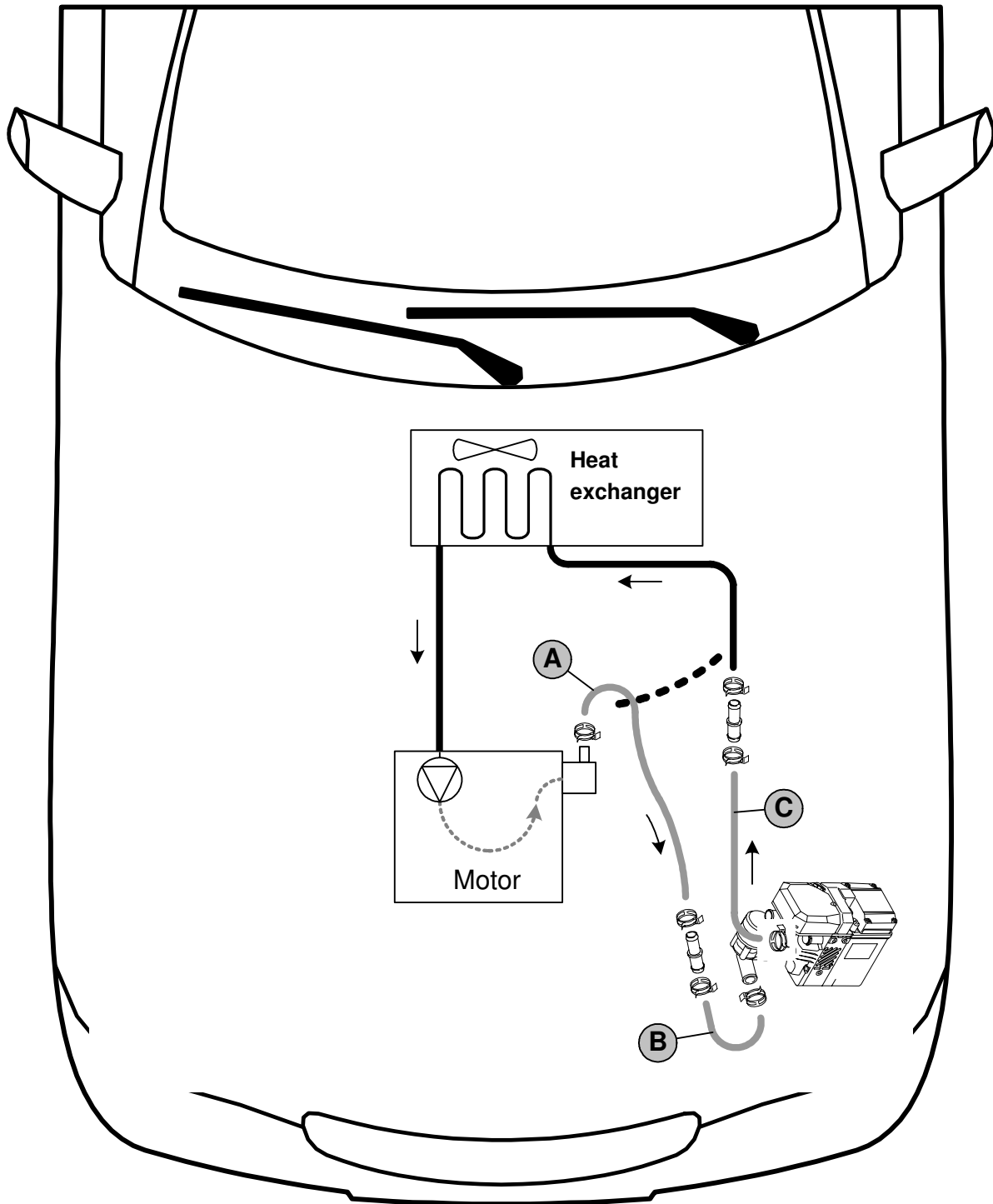

Water connection schematic 1.4 MPI

Spring clip = Ø 27 mm. All connecting pipes are Ø 20 mm x Ø 20 mm



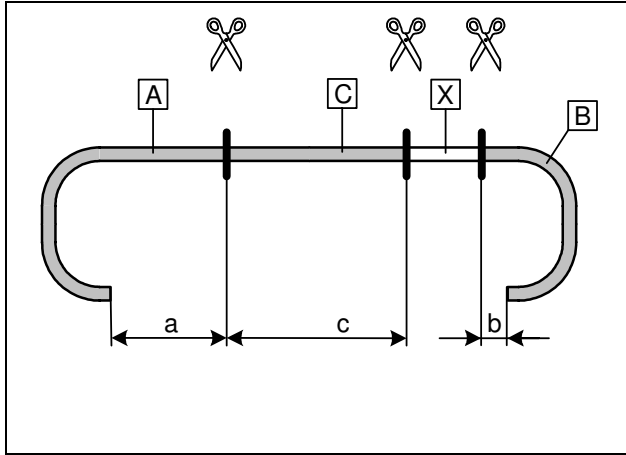

a = 600 mm
b = 50 mm
c = 770 mm

Dispose of section X



Cutting water hoses to length

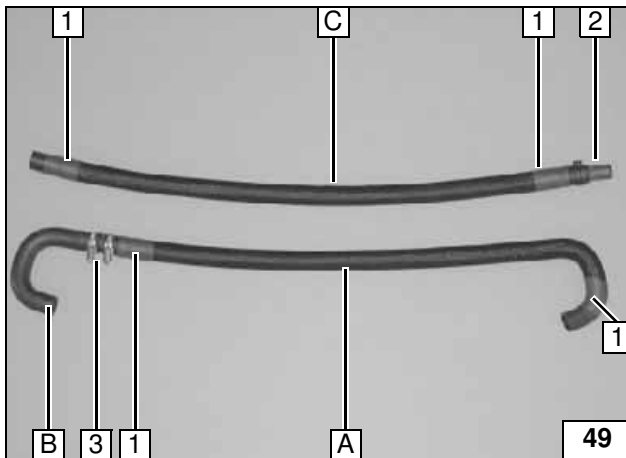

Slide the braided protective hoses onto hose A and C and cut to length

- 1 Shrink sleeve, slide on, shrink [4x]
- 2 Connecting pipe 20x20, spring clip Ø 27mm
- 3 Connecting pipe 20x20, spring clip Ø 27mm [2x]



Pre-assemble water hoses

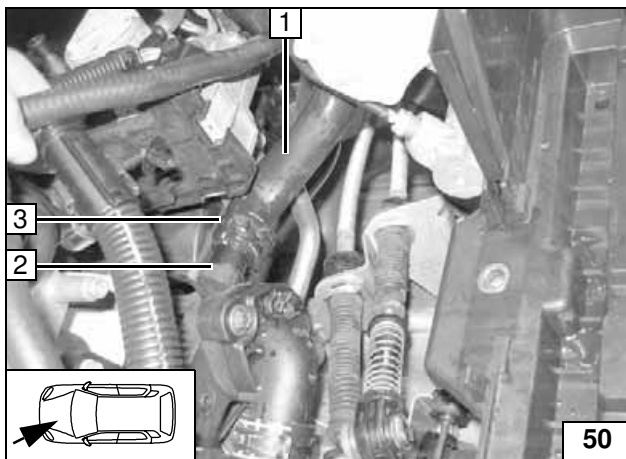

Disconnect engine outlet hose to heat exchanger inlet 1 at engine outlet supports 2
The spring clip 3 will be used again
Install battery holder



Splitting point

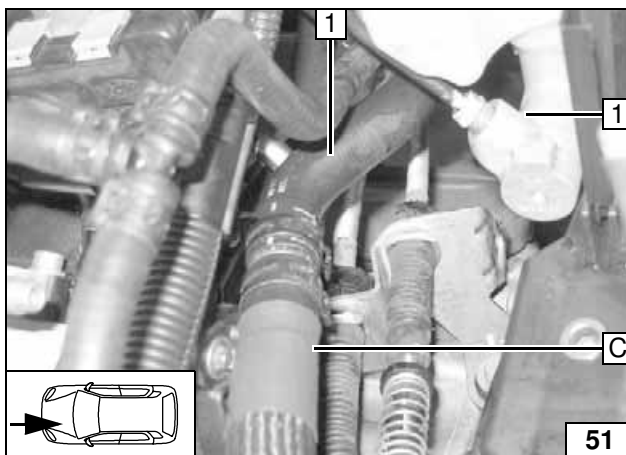

1 Hose to heat exchanger inlet

Connection at heat exchanger inlet

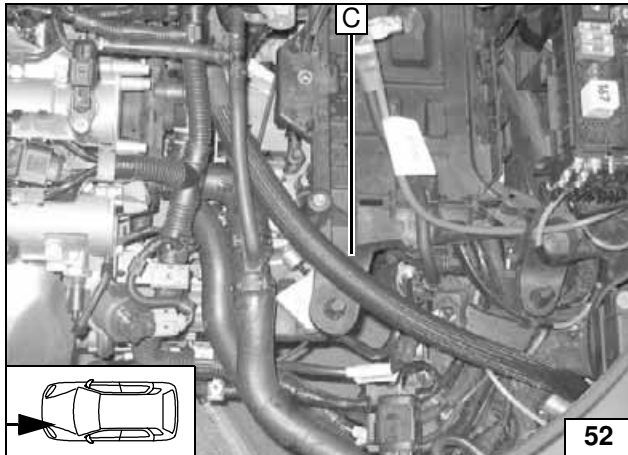

Route hose C to heater unit

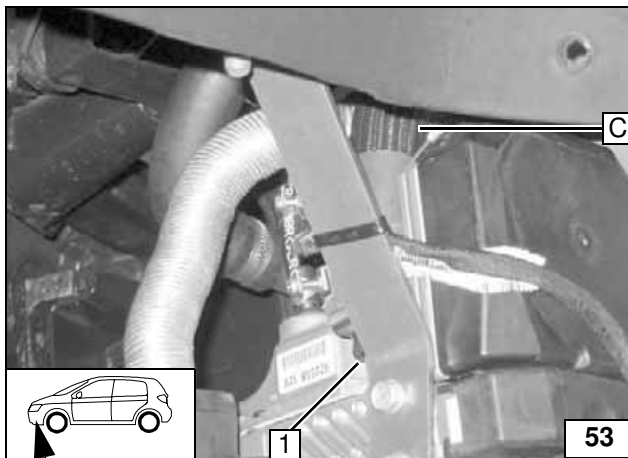

1 Heater unit outlet

Connection to the heater unit outlet

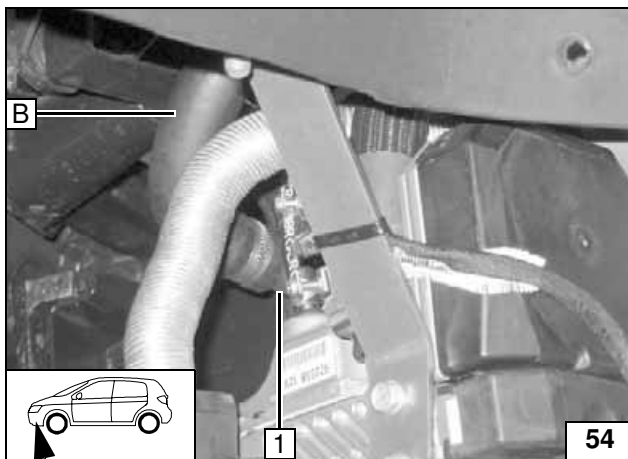

1 Heater unit inlet

Connection to the heater unit inlet

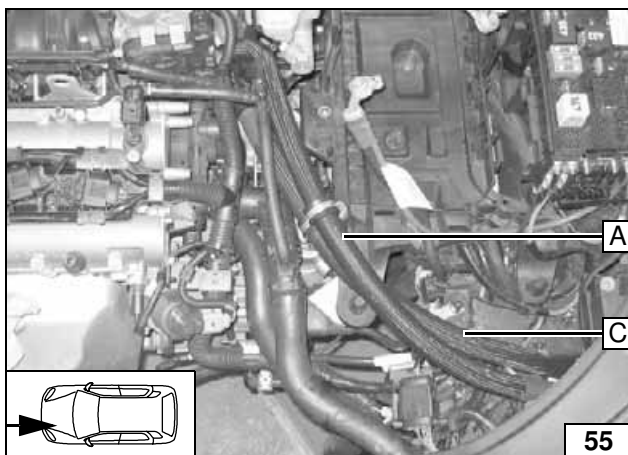

Route hose A to engine outlet

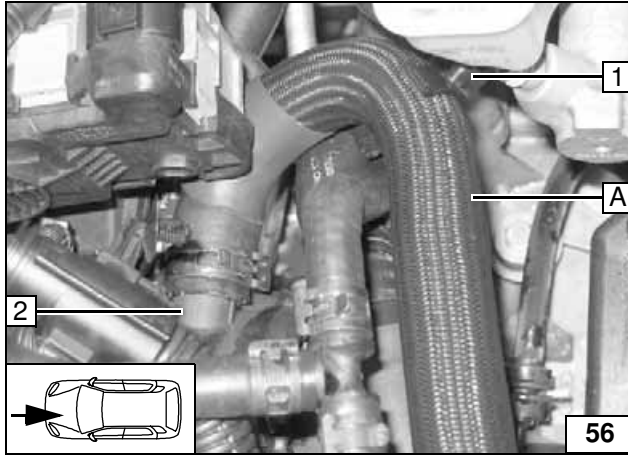

Before connecting, fill the water hoses with coolant

- 2 Engine outlet supports
- 1 Double clip 27x6 on hose **A** and brake line from main brake cylinder



**Connec-
tion at
engine
outlet**

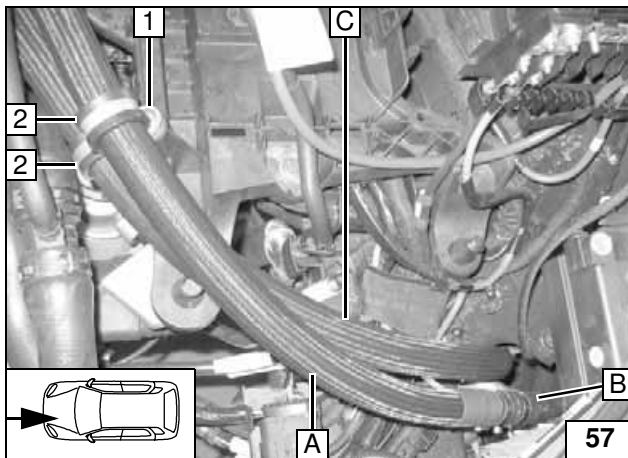

- 1 Bolt M6x20, spring washer on free thread
- 2 Rubberized hose clip Ø 29 mm [2x]

**Secure
hoses A, B
and C**

Arrange hose **A, B, C** along complete length and secure with tie-wraps





Water connection 1.6 FSI

WARNING!

Any coolant water running off should be collected using an appropriate container!

Route hoses so that they are kink-free.

Position spring clips and hose clips so that no other hose can be damaged! Tighten all hose clamps to 2.0 +0.5 Nm.

The connection should be "inline" based on the following diagram:

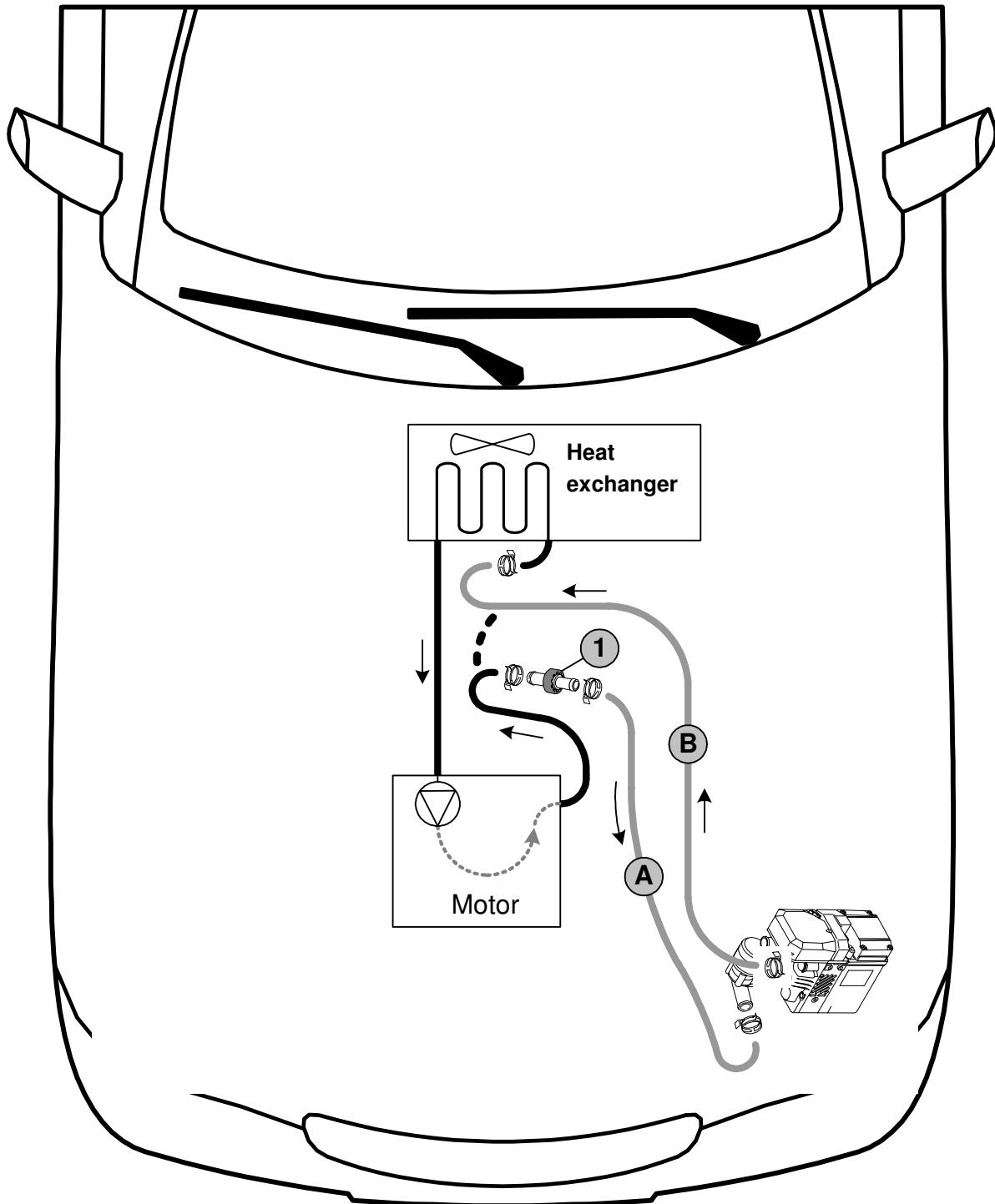

Water connection schematic 1.6 FSI

All spring clips = Ø 27 mm. Connecting pipe = Ø 20 mm x Ø 20 mm 1 = Black rubber profile



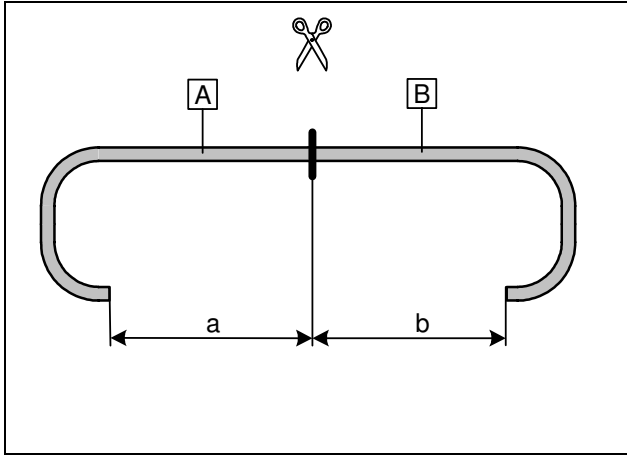

a = 1,000 mm
b = 1,050 mm



Cutting water hoses to length

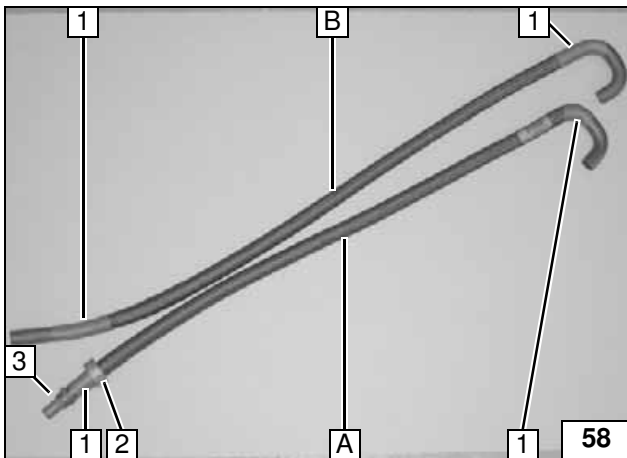

Slide braided protective hoses onto hoses **A** and **B**

- 1 Shrink sleeve, slide on, shrink [4x]
- 2 Black rubber profile
- 3 Connecting pipe 20x20, spring clip Ø 27mm



Pre-assembled water hose

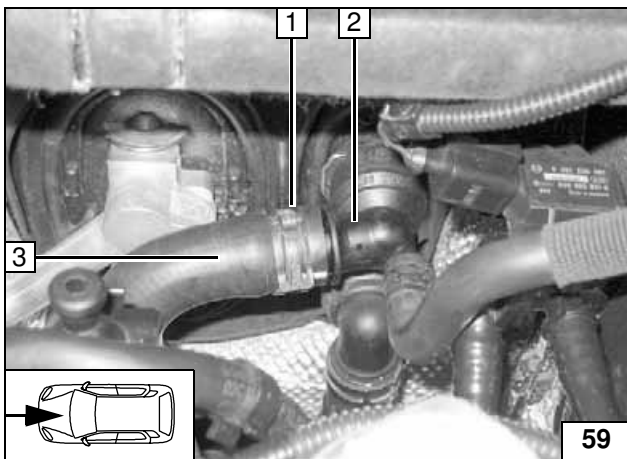

Disconnect engine outlet hose to heat exchanger inlet **1** at engine outlet supports **2**
The spring clip **1** will be used again
Install battery holder



Splitting point

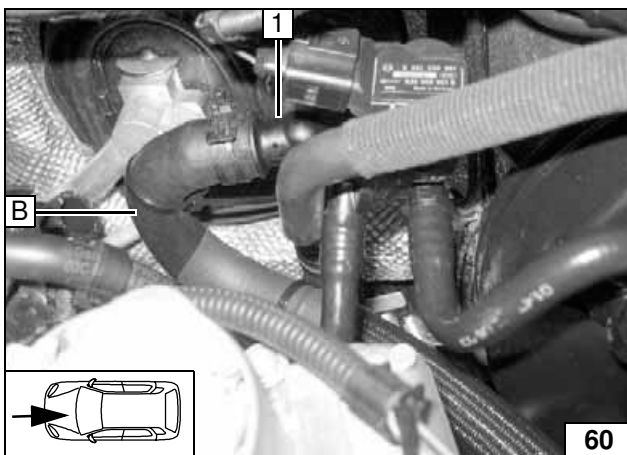

1 Heat exchanger inlet supports

Connection at heat exchanger inlet

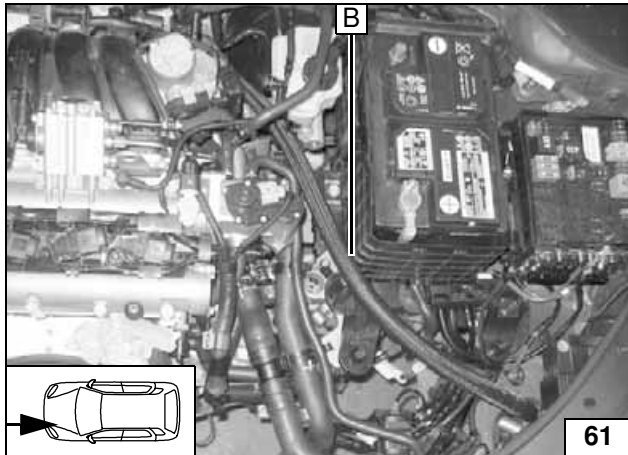

Route hose B to heater unit

1 Heater unit outlet

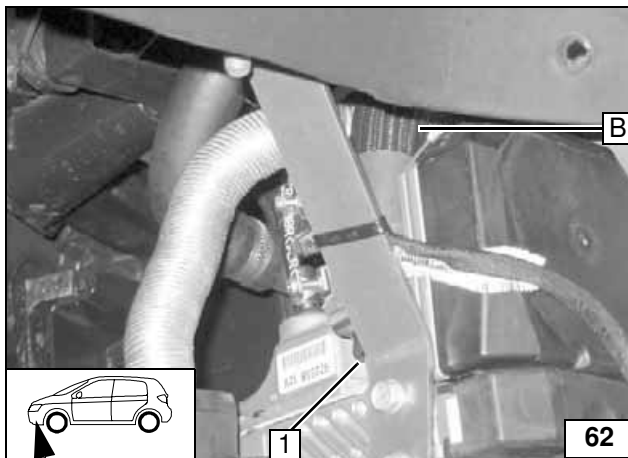

Connection to the heater unit outlet

1 Heater unit inlet

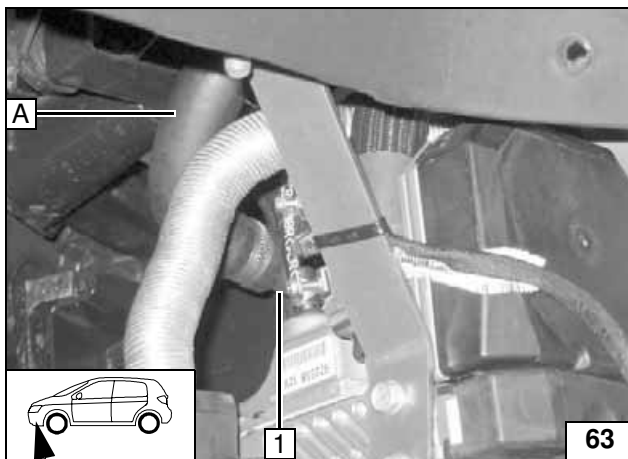

Connection to the heater unit inlet

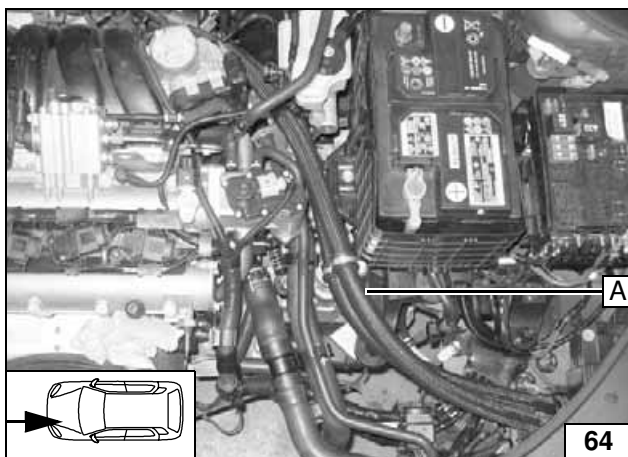

Route hose A to engine outlet

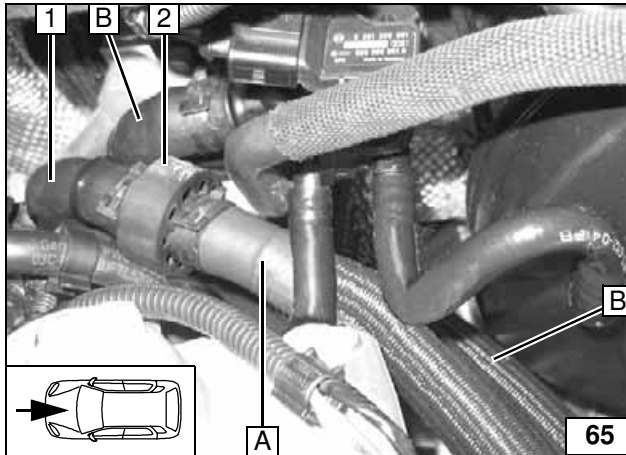

Before connecting, fill the water hoses with coolant water

- 1 Hose engine outlet
- 2 Align rubber profile at the connection



**Connec-
tion at
engine
outlet**

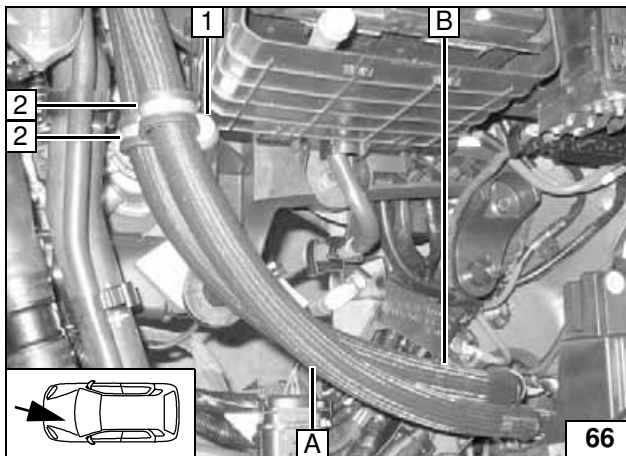

- 1 Bolt M6x20, spring washer on free thread
- 2 Rubberized hose clip Ø 29 mm [2x]

**Secure
hoses A, B**

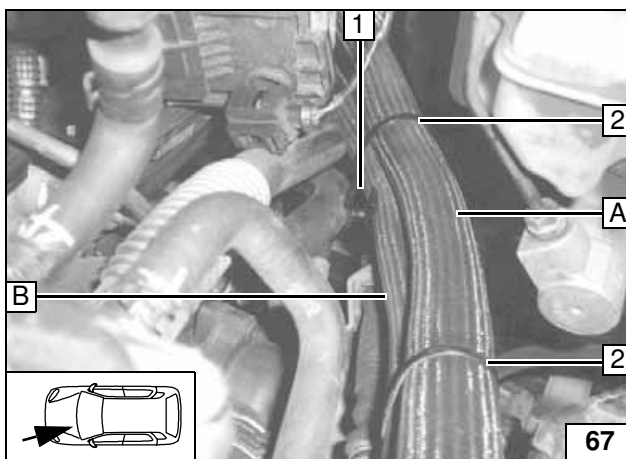

- 1 Spacer
- 2 Cable tie

**Route
hoses A, B**

Arrange hose **A, B, C** along complete length and secure with tie-wraps



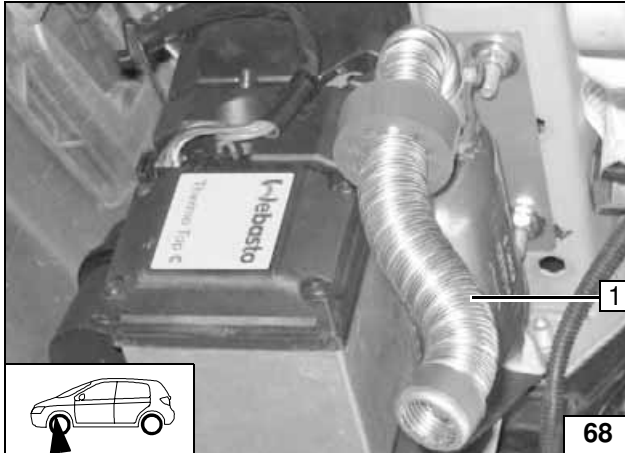
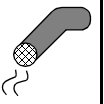

Exhaust end section

Route exhaust end sections as shown in figures 66 and 67

1 Exhaust end section

Shaping exhaust end piece

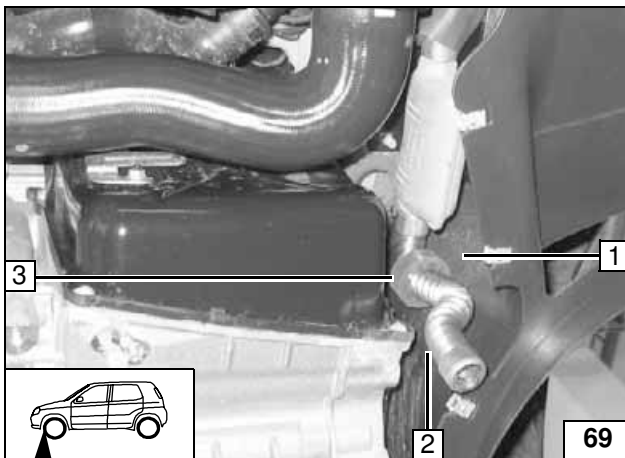

Route exhaust end piece 2 and red rubber profile 3 according to figure
Ensure there is sufficient clearance between the exhaust end piece 2 and the transmission and wheel well lining 1
(Figure shows vehicle with direct-switch-transmission)



Fitting wheel well lining

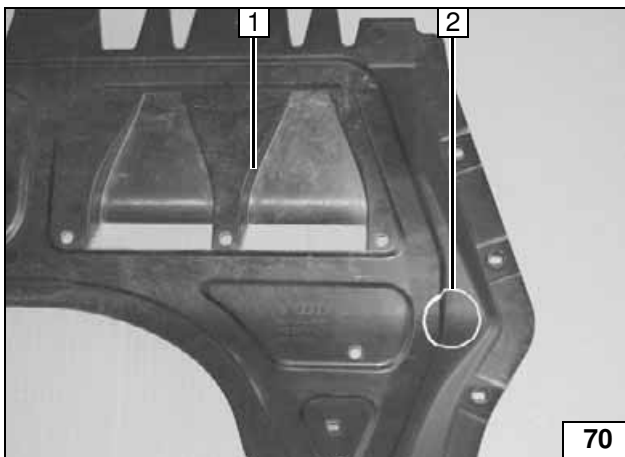

Underride protection

1 Underride protection
2 Hole Ø 42 mm

Hole in underride protection

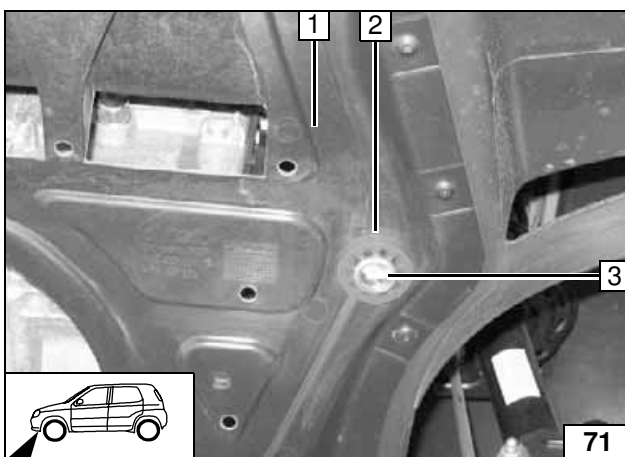

First position the red (rt) rubber profile 2 from below onto the exhaust end piece 3, then insert with groove in the underride protection 1 Align the end cap from the exhaust end piece 3 flush with red rubber profile 2 according to figure



Inserting rubber profile

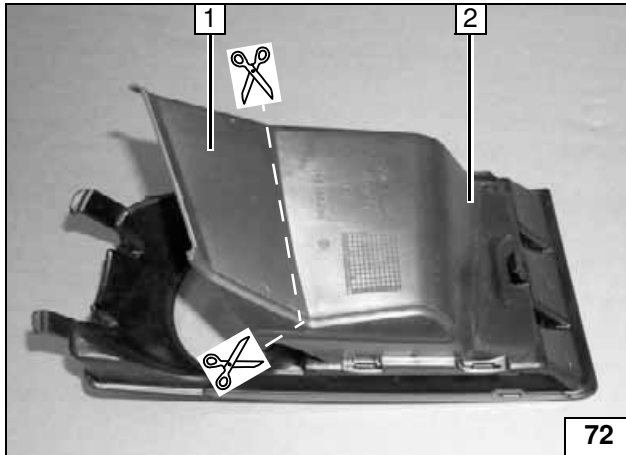
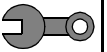

Fog lamp orifice

- 1 Trim
- 2 Fog lamp orifice (depending on equipment)

Cut fog lamp orifice

Final work

WARNING!

Reassemble disassembled components in reverse order.

Check that all hose lines, spring clips and universal clips, and all electrical connections are securely fastened.

Secure all loose cables using cable clips.

Only use manufacturer-approved coolant.

Spray heating unit components with anti-corrosion wax (Tectyl 100K, Order No. 111 329).

- Connect battery.
- Fill and bleed the coolant circuit according to the vehicle manufacturer's specifications.
- Set the time switch.
- Set vehicle heating according to "Operating instructions for the end customer"
- Check that the auxiliary heating operates properly, see operating instructions / installation instructions.
- File accompanying original vehicle "operating instructions for the end customer" in the log book
- Attach the "Switch off auxiliary heating before re-fuelling" sticker onto the left side of the B-pillar.



Changing the sensitivity of the passenger compartment monitoring

WARNING!

May only be carried out in authorized garage! Observe the valid repair manual for the vehicle in question!

- Connect the VAG Tester
- Call up Pos. 46 (Comfort system central module)
- Go to Pos. 10 (Adjustment)
- Obey the request to enter the code and enter the code 15
- Reduce the sensitivity of the interior monitoring to 50%
- Save this setting
- The adjustment of the interior monitoring is complete



Operating instructions for the end customer



Please remove page and add to the vehicle operating instructions.

Before parking the vehicle, make the following settings:

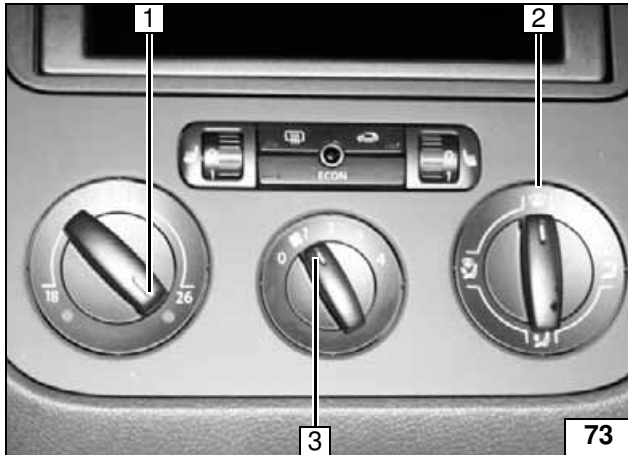

- 1 Temperature to "max."
- 2 Air outlet to windshield
- 3 Blower set to "1" or "2"

The recommended minimum heating period is 20 minutes.

Vehicles without Climatronic

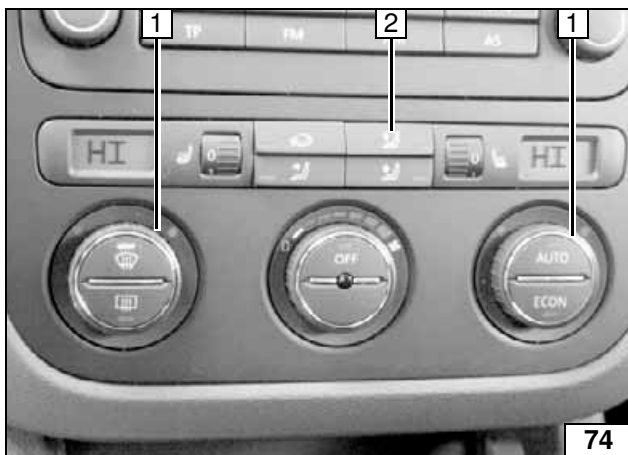

- 1 Temperature to "HI". [2x]
- 2 Air outlet upwards

The recommended minimum heating period is 20 minutes.

Vehicles with Climatronic

Information about technical specifications, construction equipment, materials, guarantees and exterior appearance refers to the period when these installation instructions were published. The manufacturer reserves the right to make changes (including changes to the technical parameters with updates of single model series).

Manufacturer Webasto AG, Germany

No. **BHW 609004A, BHW 609004B -** Germany / 07.2006
 (YHW 609004A, YHW 609004B)