

**Legend:**

- 1 Remote start antenna
- 2 Thermo Top V heater unit
- 3 Telestart receiver

**Skoda**Octavia II

**Skoda**Octavia II  
Combi

Installation

## Retrofitting the Remote start

Gasoline and diesel  
from model year 2005  
with factory-installed Webasto auxiliary heating

Order number:

**BHW 000 005**  
(YHW 000 005)

Status: 28.09.06 / Ident. No.: 9016156A



## WARNING!

### Hazard warning:

**ALWAYS follow all Webasto installation and repair instructions and observe all warning instructions.**

**Webasto does not accept any liability for defects and damage that are attributable to an installation by untrained staff.**

## Table of Contents

Validity	2
Heater Unit / Installation Kit	3
Foreword	3
General Instructions	3
Preliminary Work	3
Explanatory Notes on the Document	4
Electrical Connections	5
Final Work	10
Operating instructions for the end customer	11

## Validity

Manufacturer	Model	Type	EG-BE No. / ABE
Skoda	Octavia II	1 Z	e11 * 2001 / 116 * 0230 * ...

Diesel or gasoline vehicles only with factory-installed auxiliary heating TT-V.

Vehicle and engine types, equipment variants as well as national specifications, which are not listed in these installation instructions, have not been tested. Installation according to these installation instructions may, however, be possible.

## Heater Unit / Installation Kit

Amount	Description	Order no.:
1	T90 retrofit kit for Skoda Octavia II	9014404B
	Skoda Order No.:	BHW 000 005
		YHW 000 005

### Foreword

These installation instructions apply to Skoda Octavia II vehicles with factory installed TT-V auxiliary heating (re. validity, see page 2) from model year 2005 and later, assuming technical modifications to the vehicle do not affect installation, any liability claims excluded. Depending on the vehicle version and equipment, modifications may be necessary during installation with respect to these installation instructions.

However, where this is the case the stipulations in the "installation instructions" and "operating and maintenance instructions" should be observed.

The corresponding rules of technology and any information from the vehicle manufacturer should be observed during the installation work.

### General Instructions

Installation should be carried out according to the general, standard rules of technology. Unless specified otherwise, fasten lines and cable harnesses to original vehicle lines and cable harnesses using cable clips.

Tighten bolts with the tightening torque as listed by the manufacturer.

Sharp edges should be fitted with edge protectors (split open plastic hose).

### Preliminary Work

#### WARNING!

- Disconnect the battery.
- Remove the air filter housing
- Remove the battery.
- Remove the battery holder.
- Remove the front bumper.
- Remove the panel under the left switchboard.
- Remove the inner left fuse holder.



## Explanatory Notes on the Document

To provide you with a quick overview of the individual working steps, you will find an identification mark on the outside top right corner of the page in question.

### Mechanics

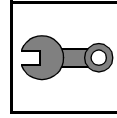

### Electrics

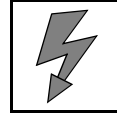

Special features are highlighted using the following symbols:



Specific risk of injury or fatal accidents.



Specific risk of damage to components.



Specific risk of fire or explosion.



Reference to general installation instructions of Webasto components or to the manufacturer's vehicle-specific documents.



Reference to a special technical feature.

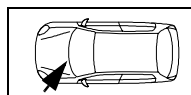
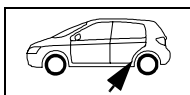

The arrow in the vehicle icon indicates the position on the vehicle and the viewing angle.



**Electrical Connections**

**Cable harness feed-through**

Original vehicle rear bulk duct from the 3 passenger compartment

- 1 Yellow KS3 wire
- 2 Antenna cable

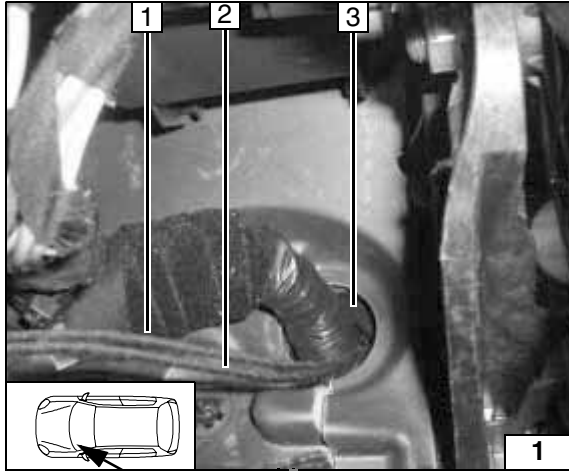

**Cable harness feed-through**

Original vehicle protective rubber sleeve from the 1 engine compartment

- 2 Yellow KS3 wire
- 3 Antenna cable

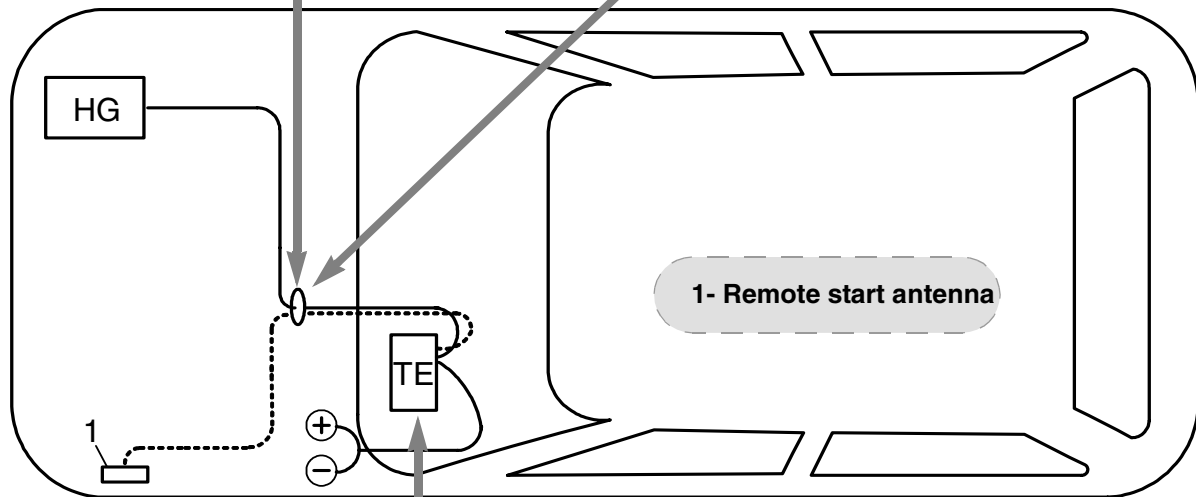
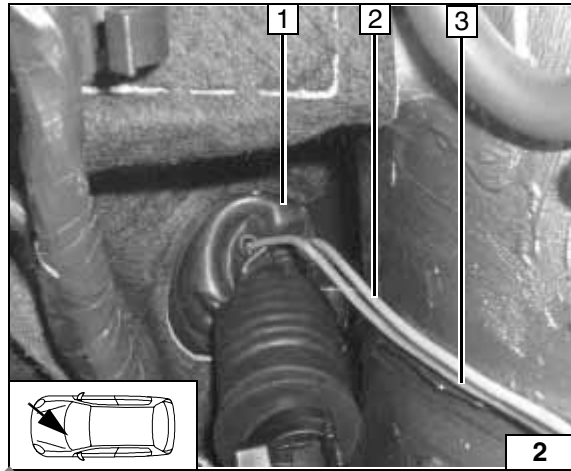

Cable harness installation diagram

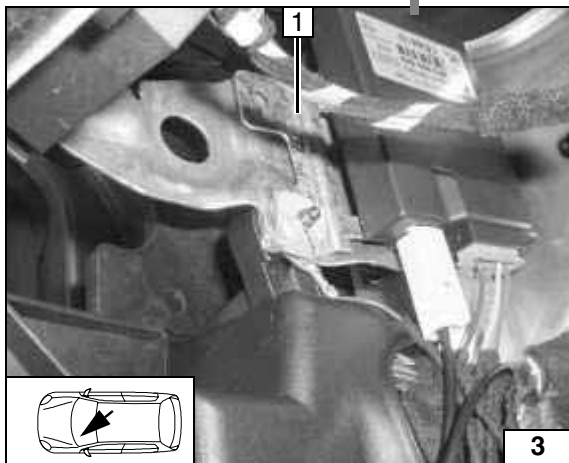

**Installation location for the Remote Start Receiver**

- 1 Remote start receiver bracket

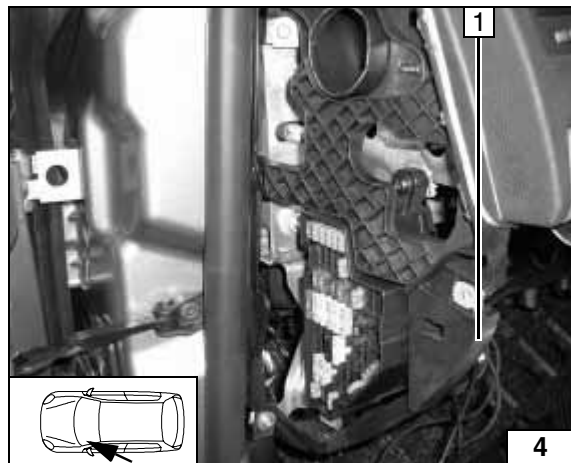

**Electrics installation**

- 1 Fuse support

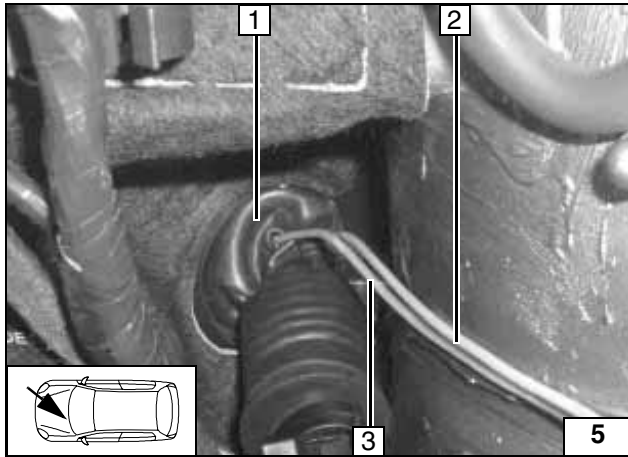

### CAUTION

Place the cable harness duct **1** on the original vehicle protective rubber sleeve to endure water-proofness. Open the cable duct on the original vehicle sleeve **1**, use the draw-in tool.

- 2** Yellow wire
- 3** Antenna cable

**Create line ducts**

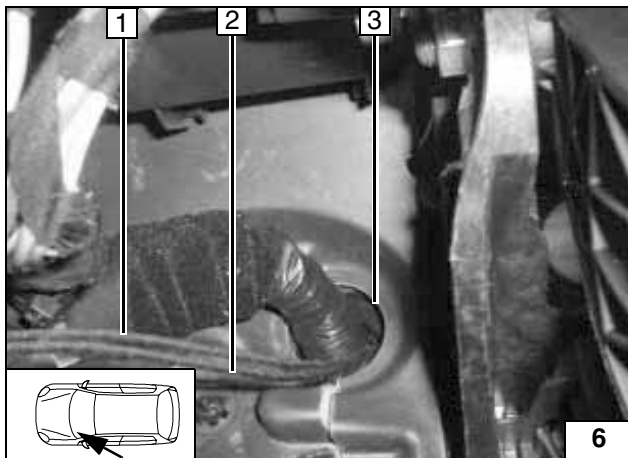

Run the yellow wire **1** from the wire harness (KS3) and the antenna cable **2** from the passenger compartment to the engine compartment through the original vehicle sleeve **3** with the draw in tool.



**Running the yellow wire - KS3 – to the engine compartment**

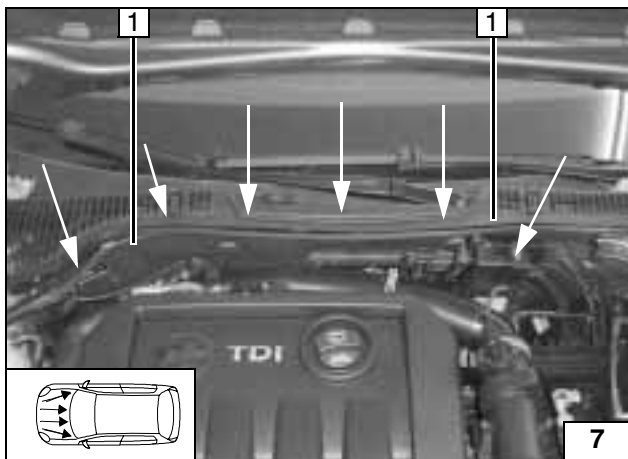

Run the yellow wire **1** behind the upper rear bulk panelling to the right to the heater unit. Use the original vehicle cable holders.



**Run the yellow KS3 wire to the heater unit**

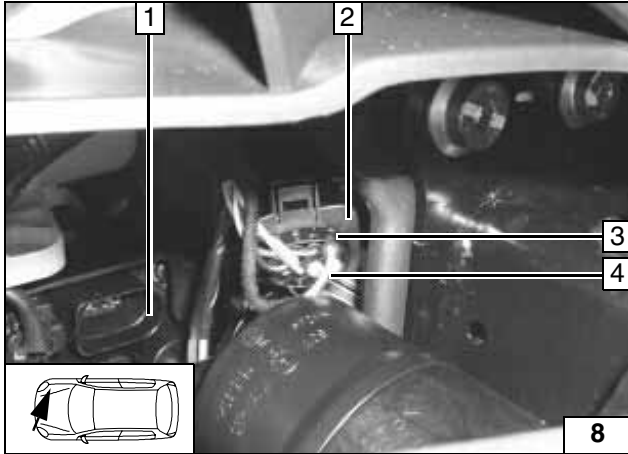

### CAUTION

The micro-timer must audibly snap into place. The 8-pin connector 2 must audibly snap into place. Pull the 8-pin connector 2 off of the connector socket for the heater unit 1. Remove the gasket stoppers 3 from plug-in position 2. Unlock connection lock for 8-pin connector 2. Insert the yellow wire 4 with micro-timer in plug-in position 2. Lock the 8-pin connector 2 lock. Insert the 8-pin connector 2 on the plug-in connector on the heater unit 1.



**Connect the yellow KS3 wire to the heater unit**

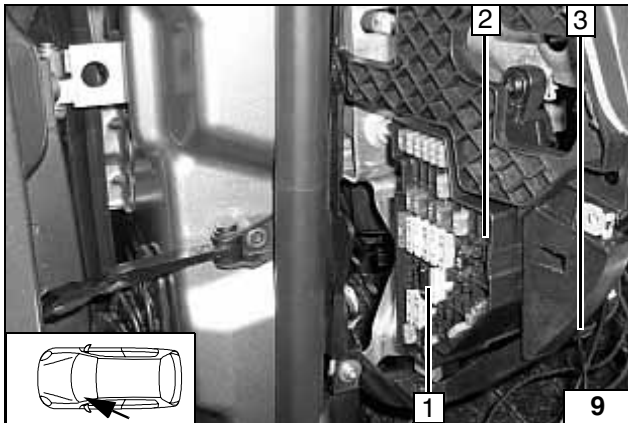

Unlock the fuse holder lock. Insert the red wire 3 from KS1 in the free plug-in position 1 on terminal 30 of the fuse holder 2. Lock the fuse holder lock.



**Red wire – KS1 – on the fuse holder**

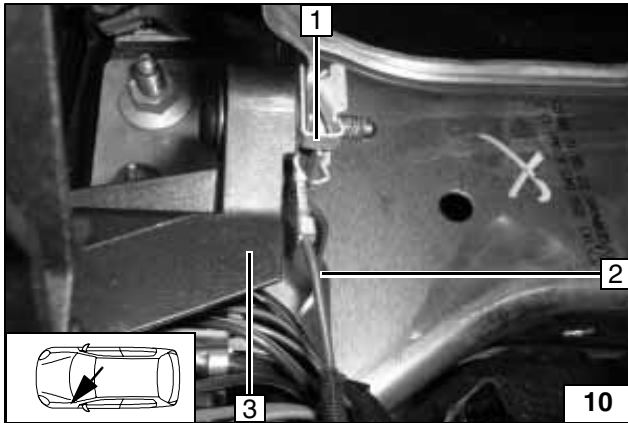

Run the brown wire 2 from KS2 to harness 1 on the fuse holder 3. Loosely fasten the fuse holder 3.



**Brown wire – KS2 – on the fuse holder**

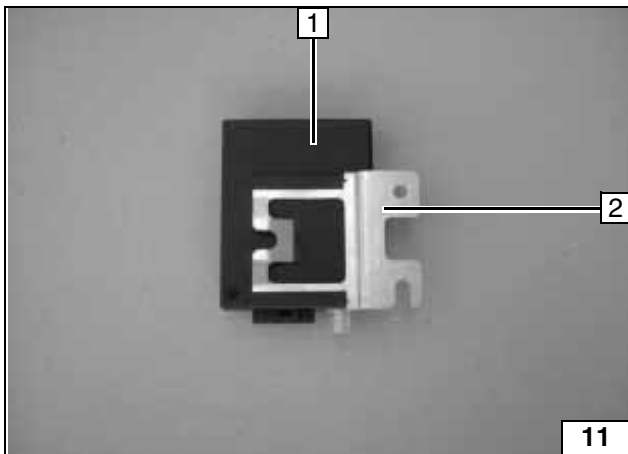

- 1 Remote start receiver
- 2 Bracket

**Pre-assembling the Remote Start Receiver**

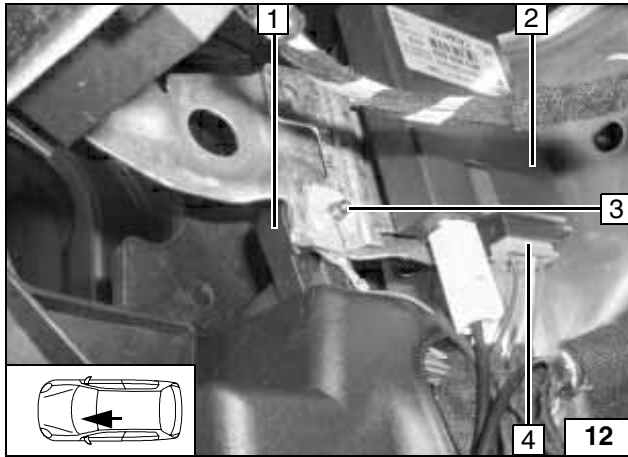

Insert the pre-assembled remote start receiver with bracket 2 on the loosely mounted fuse holder bolt 3. Tighten the bolt 3 on the fuse support 1. Insert the connector 4 on the receiver 2.



**Remote start receiver mounting**

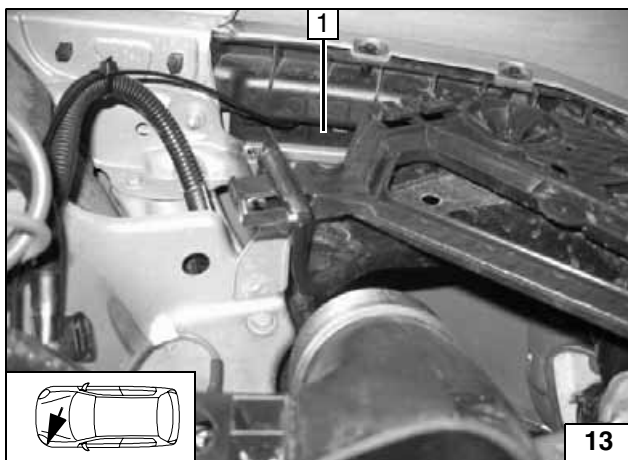

Mount the bumper, attach the antenna 1 on left inside of the bumper with double-sided Velcro.



**Remote start antenna mounting**

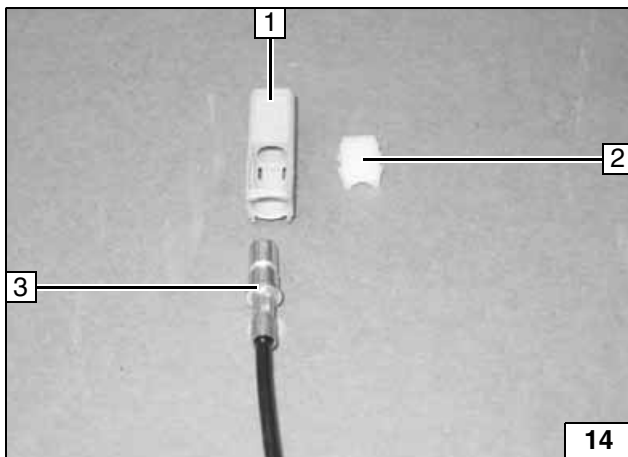

- 2 Remove mounting plate
- 1 Remove housing
- 3 Antenna cable

**Dismantle antenna connector**



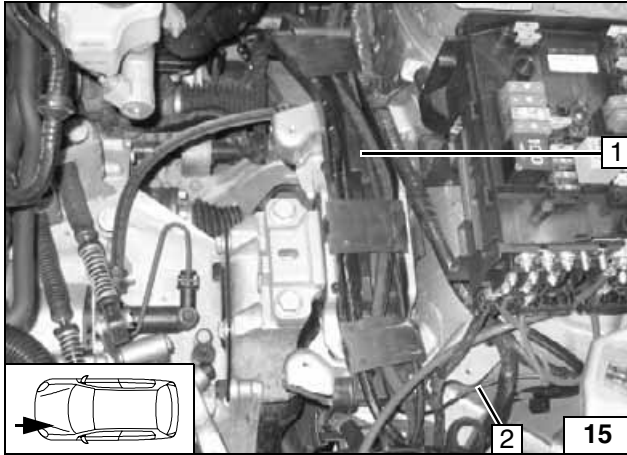

Route antenna cable **2** through cable channel **1** and then through cable feed-through into interior. Reassemble antenna connector and connect to receiver!



**Route antenna cable**

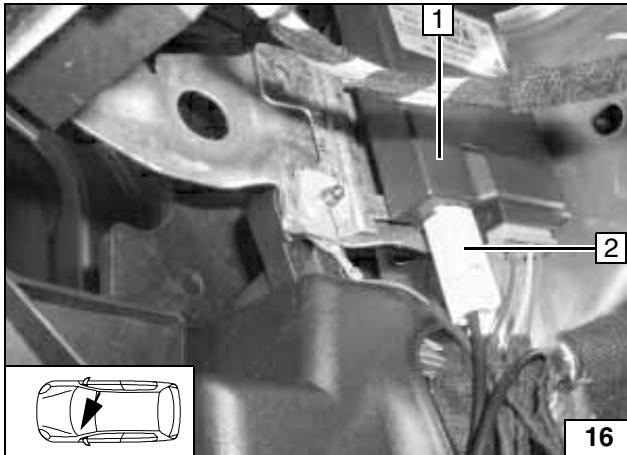

**1** Remote start receiver  
**2** Antenna plug

**Antenna plug connection to remote start**

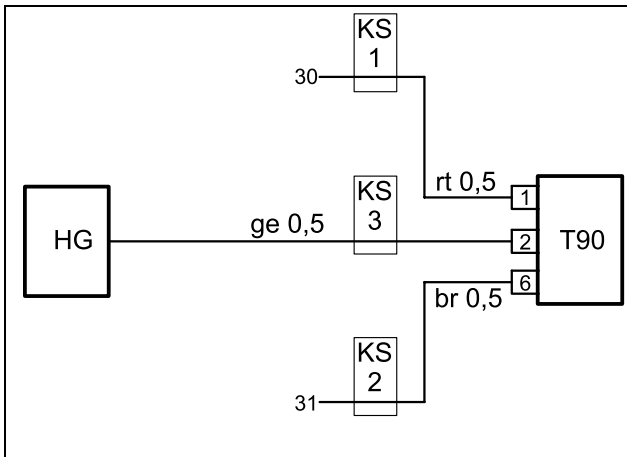

**Key to circuit diagram:**

- HG - Heater unit
- T90 - Remote start receiver
- KS - Wire harness
- rt - red
- br - brown
- ge - yellow

**Circuit diagram**

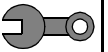

## Final Work

### WARNING!

Tie back the wire harness in the interior of the original vehicle wire harness to the fuse mount with cable clips.

Also tie back the KS3 wire with cable clips in the engine compartment if necessary.

Reassemble disassembled components in reverse order.

- Connect battery.
- Release the auxiliary heating according to the instructions.

### Release the auxiliary heater

Release the auxiliary heating for remote start with the VAS tester.

- Connect the VAS tester (OBD)
- 18- auxiliary heater
- 07 Code control units

### Variant 1 (with 3/2 way valve)

- Display = 0-0-1-1-2
- Enter = 0-1-1-1-2

### Variant 2 (without 3/2 way valve)

- Display = 0-0-0-1-2
- Enter = 0-1-0-1-2

### NOTE:

Every number in the sequence must be re-entered.



## Operating instructions for the end customer

Please remove page and add to the vehicle operating instructions.

### Remote control

The heating can also be easily switched on and off with the remote control.

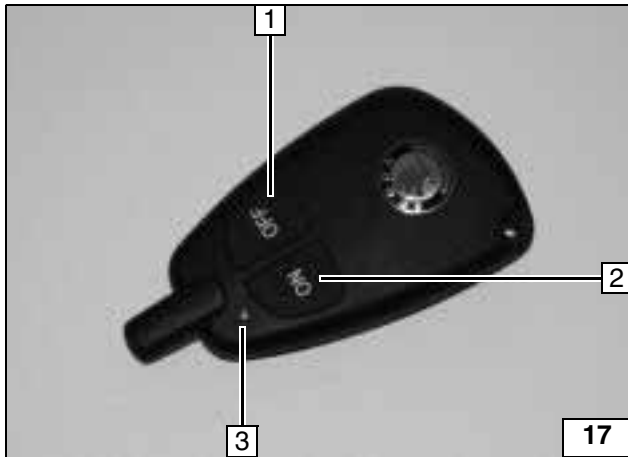

- 1 OFF button
- 2 ON button
- 3 Indicator light

#### Battery test

The indicator light **3** lights up each time the OFF **1** or ON **2** button is pressed.

You can tell the battery charge by the light color and duration.

- If the indicator light **3** briefly lights green, the battery charge is sufficient.
- If the indicator light **3** blinks red for about 3 seconds, the batteries should be changed as soon as possible.
- If the indicator light **3** light red for about 5 seconds, the batteries must be changed. The remote control may not work correctly.

- To switch the heater on, press ON (2) until the light **3** lights briefly.
- To switch the heater off, press OFF (1) until the light **3** lights briefly.

#### Range

The transmitter and batteries are in the key. The receiver is inside the vehicle.

A range of 250 meters in an open area is ensured at any time.

The electronic key has a range of up to 500 meters when the batteries are full.

However, obstacles between the electronic key and the vehicle, poor weather and weak batteries can reduce the range considerably.

The heating can only be switched on and off with the remote control when there is at least 2 meters between the remote control and the vehicle.

If the indicator light **3** blinks or lights at temperatures below freezing, it may help to warm the batteries up above the freezing point.

#### Training the remote transmitter

- Remove fuse 1A (black) from the blade-type fuse holder (5) (disconnect power).
- Wait at least 5 seconds.
- Insert the fuse in the blade-type fuse holder and, within 5 seconds, press the off button **1** for at least one second.

#### NOTE:

This training can be repeated as often as necessary, the "oldest" transmitter is always deleted.

**Remote control**

Information on technical details, construction, equipment, materials, warranties, and external appearance refer to the time frame during which these installation instructions were printed. The manufacturer reserves the right to technical changes (including changes to the technical parameters with changes to individual model measures).

Manufacturer: Webasto AG, Germany

**No. BHW 000 005**  
(YHW 000 005)

Germany / 09.2006