

Water Heater Unit



Thermo Top E Additional Heater ^{e1} 00 0003

Thermo Top C Additional Heater ^{e1} 00 0002

Installation Instructions



SUBARU Legacy / Outback

Gasoline

from Model Year 2004

Left-hand drive vehicle



WARNING!

Hazard warning:

Incorrect installation or repair of Webasto heating systems may cause a fire or result in the emission of carbon monoxide, which can be fatal. Serious or fatal injuries can be caused as a result.

Specialist company training, technical documentation, specialized tools and equipment are required to install and repair Webasto heating and cooling systems.

NEVER attempt to install or repair Webasto heating or cooling systems if you have not successfully completed the company training and thereby acquired the required technical skills, or if you do not have access to the required technical documentation, tools and equipment needed to carry out correct installation and repairs.

ALWAYS follow all Webasto installation and repair instructions and observe all warnings.

Webasto does not accept any liability for defects and damage that are attributable to installation by untrained staff.

Table of Contents

Validity	2	Preparing heater unit	12
Heater Unit/Installation Kit	3	Preparing installation location	13
Foreword	3	Exhaust system with manual transmission	16
General Instructions	3	Exhaust system with automatic transmission	17
Special Tools	3	Installing heater unit	18
Explanatory Notes on Document	4	Combustion air	19
Preliminary Work	5	Coolant connection	20
Heater unit installation location	5	Fuel Connection	23
Electrical Connections	6	Final Work	27
Fan connection Version A	7	Operating Instructions for End Customer	28
Fan connection Version B	9		
Remote option (Telestart)	11		

Validity

Manufacturer	Model	Type	EG-BE No./ABE
SUBARU	Legacy / Outback	BL / BP	e1 * 2001/116 * 0228 * ...
SUBARU	Legacy / Outback	BL / BPS	e1 * 2001/116 * 0256 * ...

Engine type	Engine model	Output in kW	Displacement in cm ³
EJ20	Gasoline	101	1994
EJ20	Gasoline	110	1994
EJ20	Gasoline	121	1994
EJ25	Gasoline	121	2457
EJ25	Gasoline	127	2457
EZ30	Gasoline	180	3000

Vehicle and engine types, equipment variants and national specifications not listed in these installation instructions have not been tested. However, installation according to these installation instructions may be possible.

The installation location of a digital timer and summer/winter switch should be confirmed with the end customer before installation.

Heater Unit/Installation Kit

Quantity	Description	Order No.:
1	Retail accessories with desired heater control	See price list
1	Installation Kit for SUBARU Legacy / Outback Gasoline from MY 04	1302625B

Heater unit recommended for the respective vehicle class:

Vehicle	Heater unit
Compact car	Thermo Top E
Mid-size car, station wagon	Thermo Top C

The selection of the heater unit is based on the passenger compartment size of the vehicle and the level of comfort required by the customer!



Foreword

These installation instructions apply to SUBARU Legacy / Outback Gasoline vehicles - for validity, see page 2 - from model year 2004 and later, assuming technical modifications to the vehicle do not affect installation, any liability claims excluded. Depending on the vehicle version and equipment, modifications may be necessary during installation with respect to these installation instructions.

However, the stipulations in the "installation instructions" and "operating and maintenance instructions" for the *Thermo Top C/P/E* must always be observed.

The corresponding rules of technology and any information from the vehicle manufacturer should be observed during the installation work.

General Instructions

Installation should be carried out according to the general, standard rules of technology. Unless specified otherwise, fasten hoses, lines and wiring harnesses to original vehicle lines and wiring harnesses using cable ties.

Sharp edges should be fitted with edge protectors (split-open plastic hose).

Spray unfinished body areas, e.g. drilled holes, with anti-corrosion wax (Tectyl 100K, Order No. 111329).

Please ask customers to bring in the vehicle with as little fuel in the fuel tank as possible (max 1/4 full)!

Special Tools

- Torque wrench for 2.0 - 10 Nm
- Hose clamping pliers
- Metric thread-setter kit

Explanatory Notes on Document

To provide you with a quick overview of the individual working steps, you will find an identification mark on the outside top right corner of the page in question.

Mechanical system

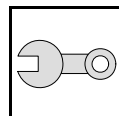

Electrical system

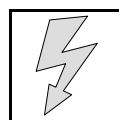

Coolant connection

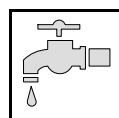

Fuel connection

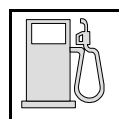

Exhaust system

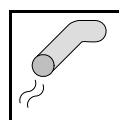

Combustion air

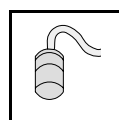

Special features are highlighted using the following symbols:



Specific risk of injury or fatal accidents.



Specific risk of damage to components.



Specific risk of fire or explosion.



Reference to general installation instructions of Webasto components or to the manufacturer's vehicle-specific documents.



Reference to a special technical feature.

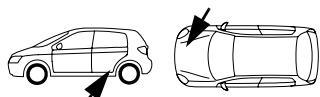

The arrow in the vehicle icon indicates the position on the vehicle and the viewing angle.

Preliminary Work

WARNING!

- Empty the fuel tank.
- Disconnect the battery "earth" or "ground" connection.
- Depressurize the cooling system.
- Copy the factory number from the original type label to the duplicate type label.
- Remove years that do not apply from the duplicate label.
- Attach the duplicate label (type label) in the appropriate place.
- Remove the rear bench seat
- Open the right-hand fuel sender service lid.
- Remove the footwell trim on the driver's side.
- Remove the lower instrument panel trim on the driver's side.
- Remove the A-pillar trim in the footwell on the front passenger side.
- Remove the lower B-pillar trim on the front passenger side.
- Remove the door sill cover on the front passenger side.
- Remove the right-hand fuel tank trim.

Remove page 28 "Operating Instructions for End Customer" and add to the vehicle operating instructions.

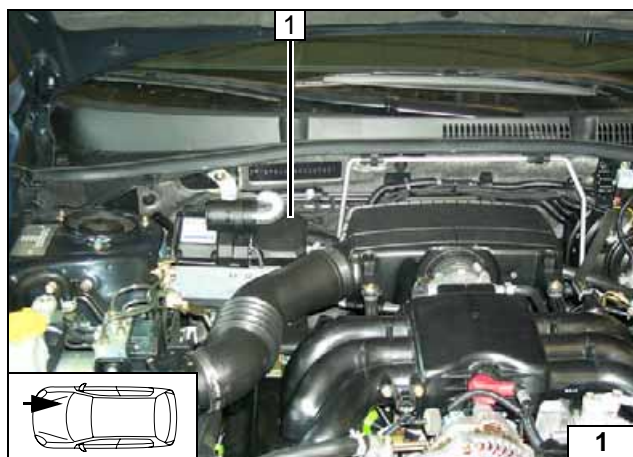

Heater unit installation location

- 1 Heater unit

Installation location



Electrical Connections

Pass through of fuel line and wiring harness of metering pump

Leave approx. 50 cm of fuel line in engine compartment.

- 1 Protective rubber plug
- 2 Metering pump wiring harness
- 3 Mecanyl fuel line

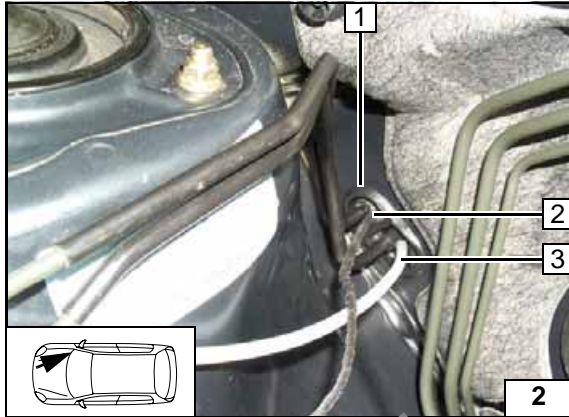

Wiring harness pass through

With automatic transmission, use protective rubber plug in firewall on driver's side.

- 1 Protective rubber plug
- 2 Original vehicle wiring harness

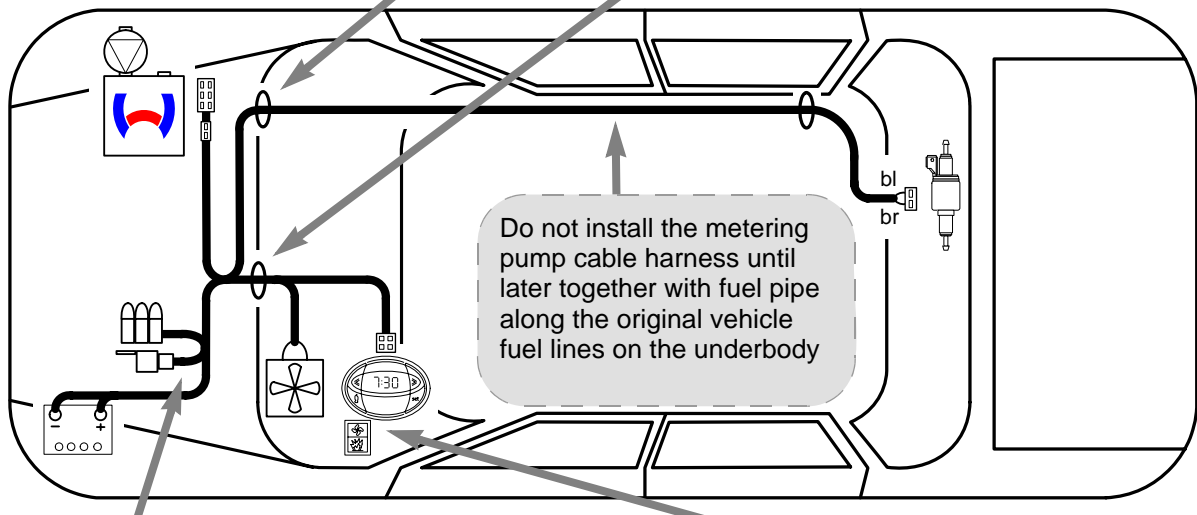
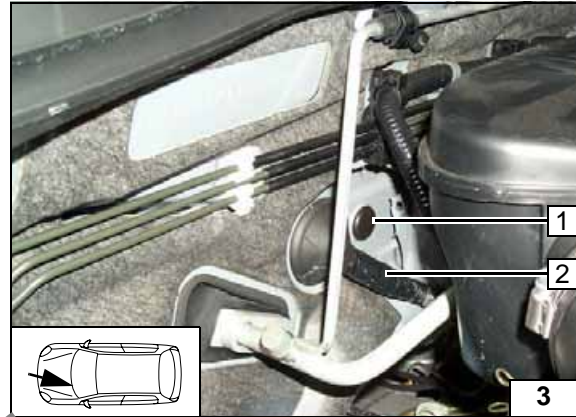

Wiring harness installation diagram

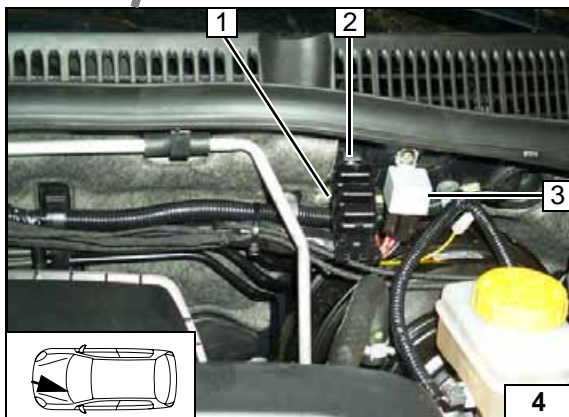

Fuse holder, relay K3

Cutting out insulating mat.

- 1 Fuse holder (replace F25A with 7.5 A)
- 2 Retaining plate of fuse holder, 4 mm dia. hole, 5.5x9.5 self-tapping screw
- 3 K3 relay, 4 mm dia. hole, 5.5x9.5 self-tapping screw

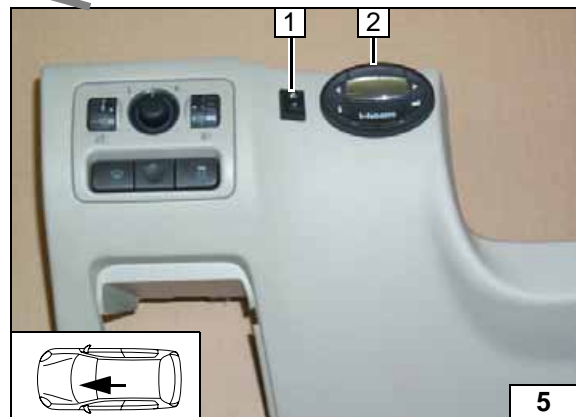

Digital timer and summer/winter switch option

- 1 Summer/winter switch, drilled hole 12 mm dia.
- 2 Digital timer



Fan connection Version A

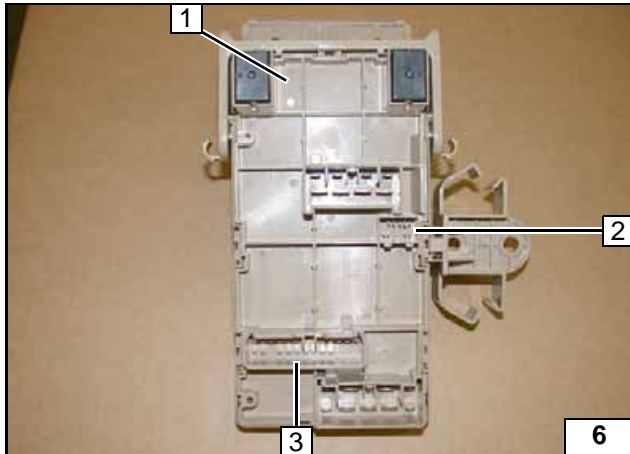

- 1 Remove central electrical box, back
- 2 Socket of 10-pin connector
- 3 Socket of 24-pin connector

Discon-necting connector from cen-tral electri-cal box

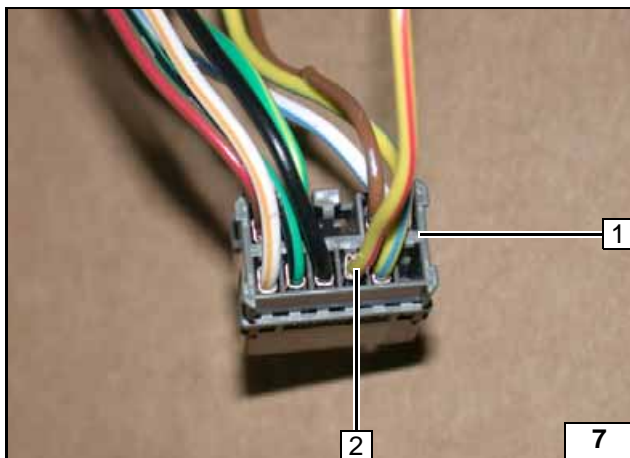

- 1 10-pin connector, gray D (B152) disconnected
- 2 Yellow/red (ge/rt) wire from PIN 7

10-pin connector

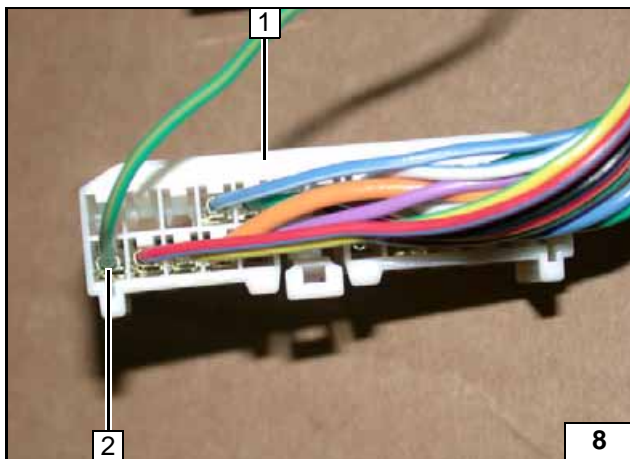

- 1 24-pin connector white C (B52) disconnected
- 2 Green/yellow (gn/ge) or green/orange (gn/or) wire from PIN 1

24-pin connector

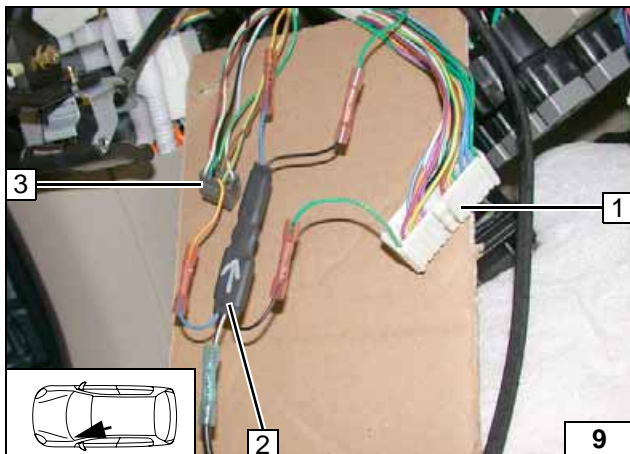

Make connections as shown in the wiring diagram with the connectors provided.

- 1 24-pin connector white C (B52)
- 2 Diode group D1
- 3 10-pin connector, gray D (B152)



Connect-ing diode group

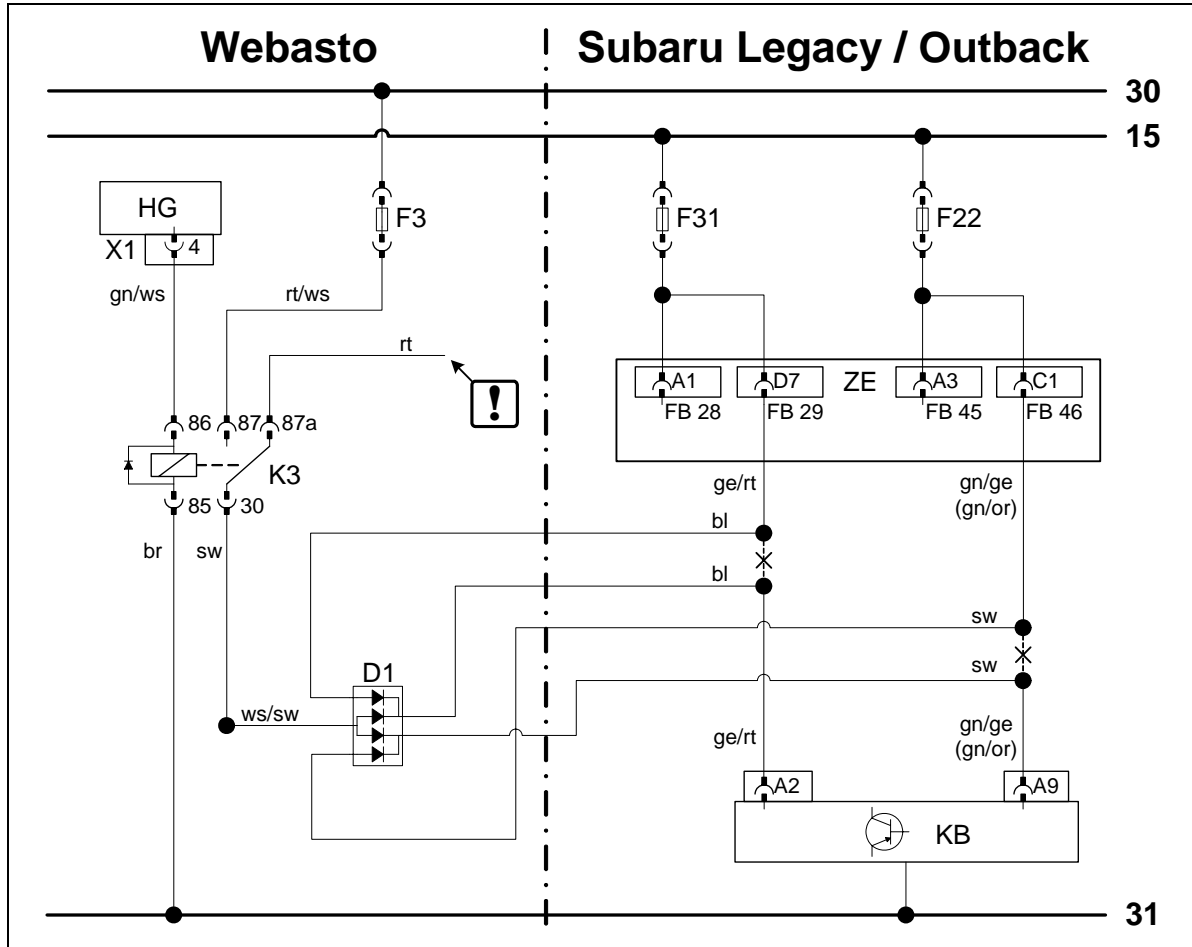

Wiring diagram for Version A

Webasto components		Vehicle components		Colors and symbols	
HG	Heater unit TT-C/P	F31	Fuse, 7.5 A	rt	red
X1	6-pin connector	F22	15 A fuse	ws	white
F3	Replace 25 A fuse with 7.5 A fuse	ZE	Central electrical box	sw	black
K3	Fan relay	A1	Connector A (i5) PIN 1	br	brown
D1	Diode group1	D7	Connector D (B152) PIN 7	gn	green
		A3	Connector A (i5) PIN 3	bl	blue
		C1	Connector C (B52) PIN 1	ge	yellow
		KB	Air-conditioning control panel	or	orange
		A2	Connector A (B282) PIN 2	!	Insulate wire ends and tie back
		A9	Connector A (B282) PIN 9	X	Cutting point
					Wiring colors may vary.

Legend

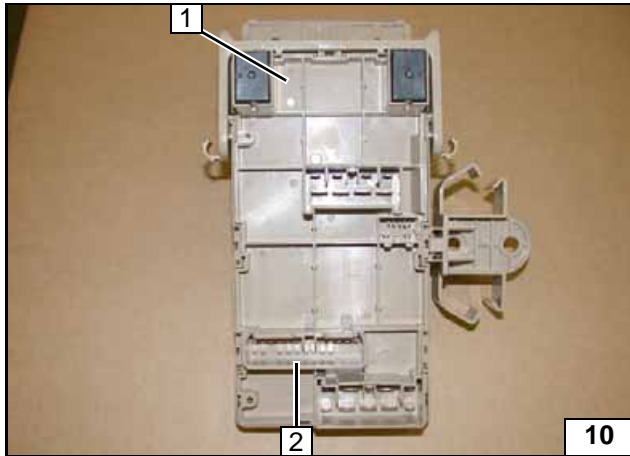

Fan connection Version B

- 1 Remove central electrical box, back
- 2 Socket of 24-pin connector

Discon-necting connector from central electrical box

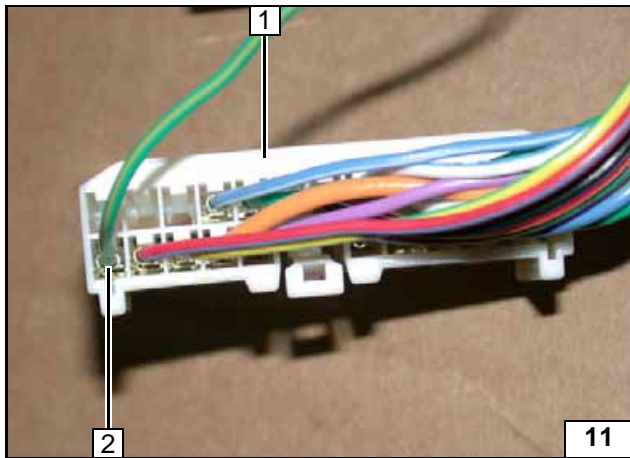

- 1 24-pin connector white C (B52) disconnected
- 2 Green/yellow (gn/ge) or green/orange (gn/or) wire from PIN 1

24-pin connector

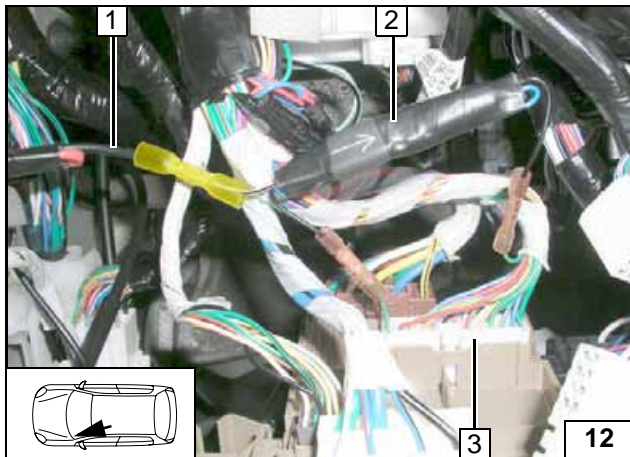

Make connections as shown in the wiring diagram with the connectors provided.

- 1 Black (sw) wire from K3/30
- 2 Diode group D1
- 3 24-pin connector white C (B52)



Connect-ing diode group

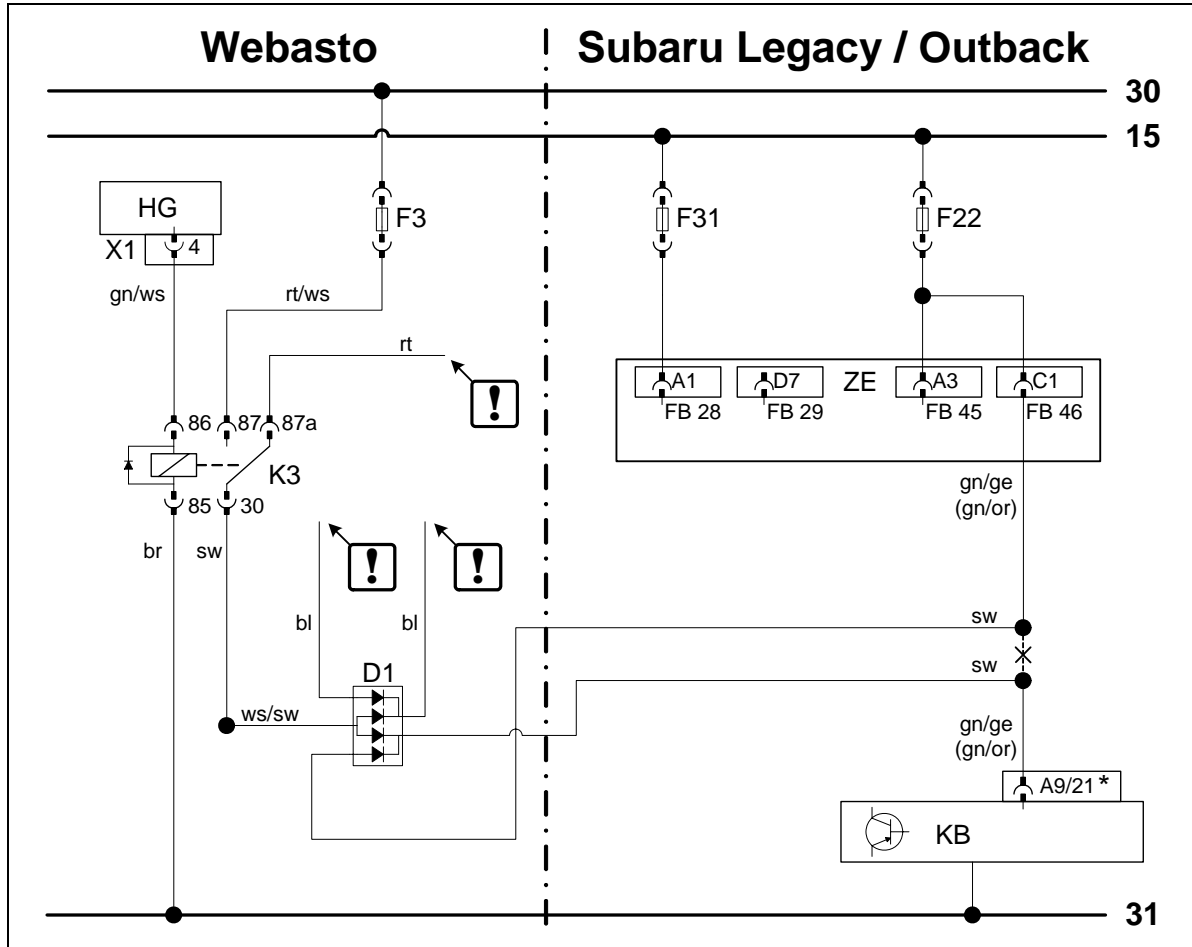

Wiring diagram for Version B

Webasto components		Vehicle components		Colors and symbols	
HG	Heater unit TT-C/P	F31	Fuse, 7.5 A	rt	red
X1	6-pin connector	F22	15 A fuse	ws	white
F3	Replace 25 A fuse with 7.5 A fuse	ZE	Central electrical box	sw	black
K3	Fan relay	A1	Connector A (i5) PIN 1	br	brown
D1	Diode group1	D7	Connector D (B152) PIN 7	gn	green
		A3	Connector A (i5) PIN 3	bl	blue
		C1	Connector C (B52) PIN 1	ge	yellow
		KB	Air-conditioning control panel	or	orange
		A9/21*	Vehicle-dependent Connector B282 (16-pin) PIN 9 or connector B282 (40-pin) PIN 21	!	Insulate wire ends and tie back
				X	Cutting point
					Wiring colors may vary.

Legend

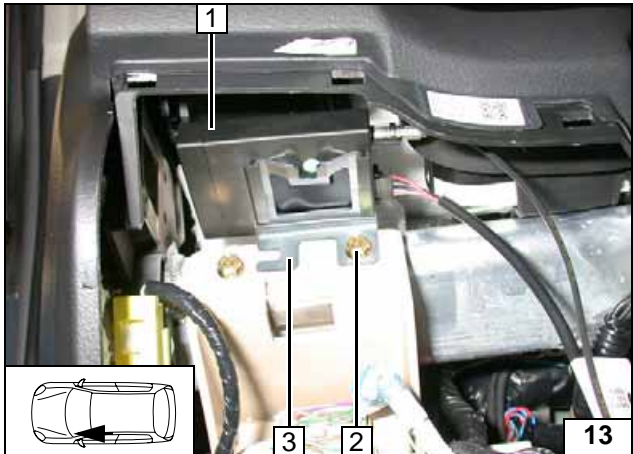

Remote option (Telestart)

- 1 Receiver
- 2 Original vehicle bolt
- 3 Bracket, angle down 90°



Installing receiver

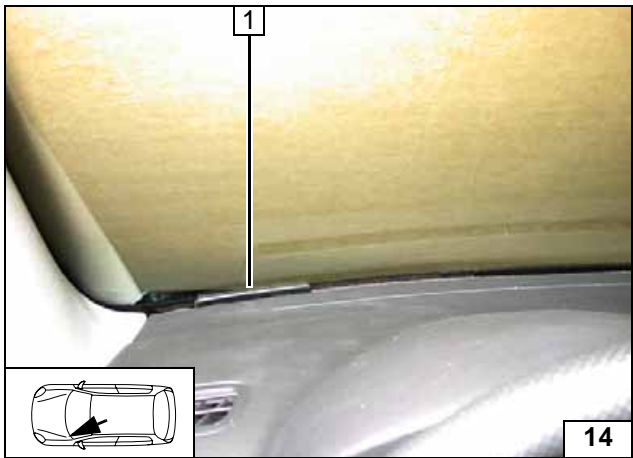

- 1 Antenna

Installing antenna

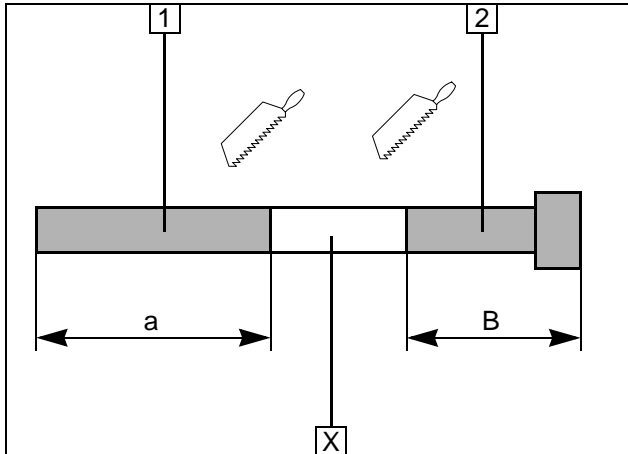
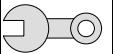

Preparing heater unit

- 1 Exhaust pipe
a = 150 mm
- 2 Exhaust end section
b = 450 mm

Discard section X

Preparing exhaust pipe

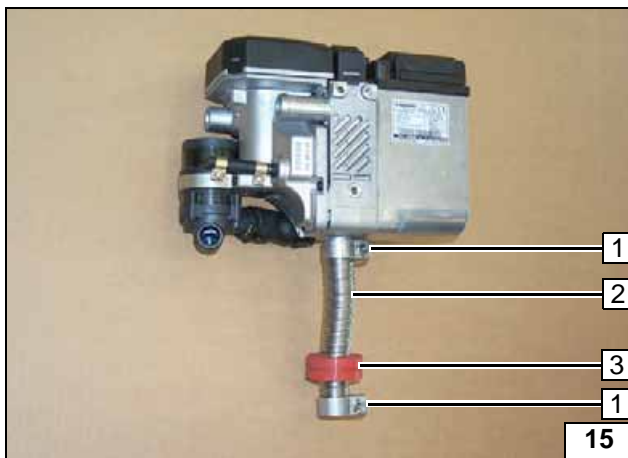

Loosely mount lower hose clamp.



- 1 Hose clamp [2x]
- 2 Exhaust pipe
- 3 Red (rt) rubber isolator with groove

Preassembling exhaust pipe

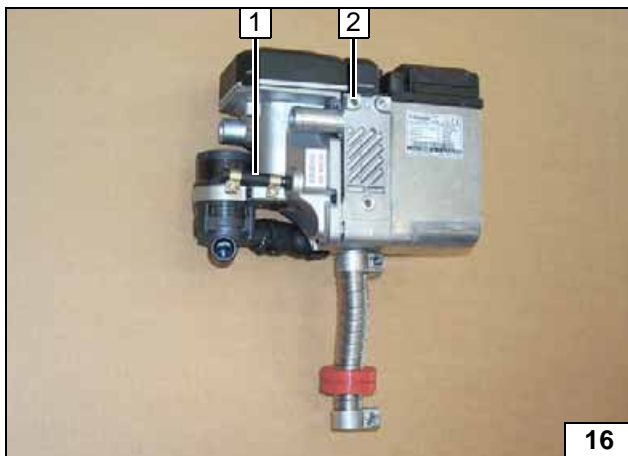

Loosely mount outer hose clamp.



- 1 Hose section, 10 mm dia. hose clamps [2x].
- 2 Precut thread with Eject screw.

Premounting fuel connection on heater unit

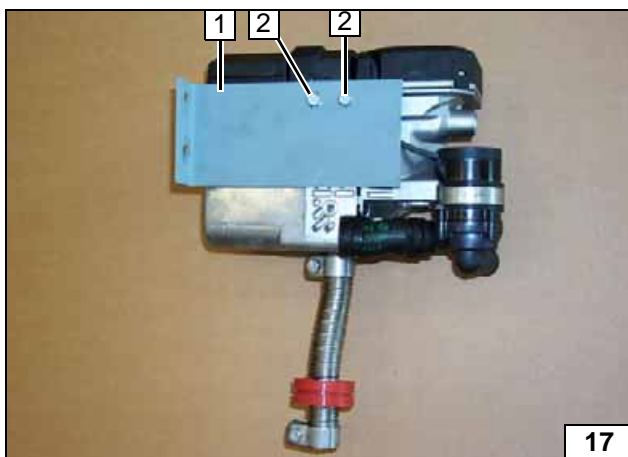

Loosely mount Eject screws.



- 1 Bracket
- 2 Eject screw [2x]

Preassembling bracket on heater unit

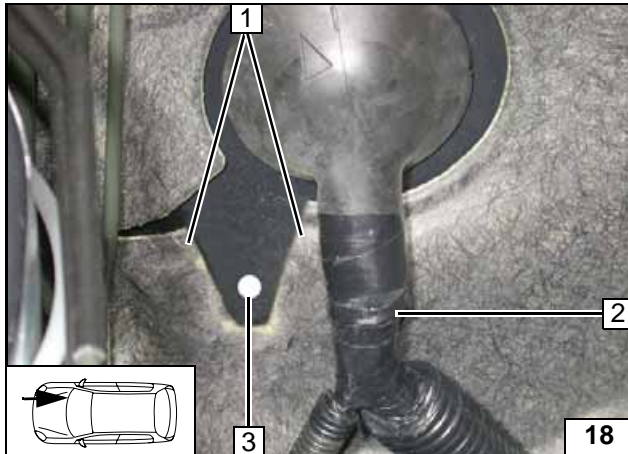
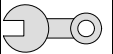

Preparing installation location

- 1 Cut out insulating mat
- 2 Original vehicle wiring harness
- 3 6 mm dia. hole

Hole in fire wall

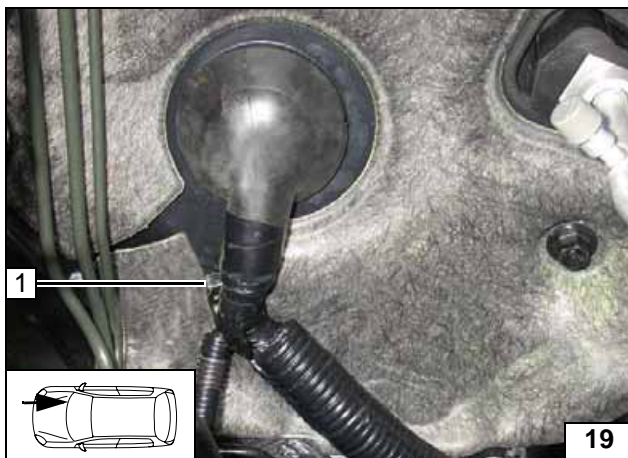

- 1 Cable clip

Tie back wiring harness

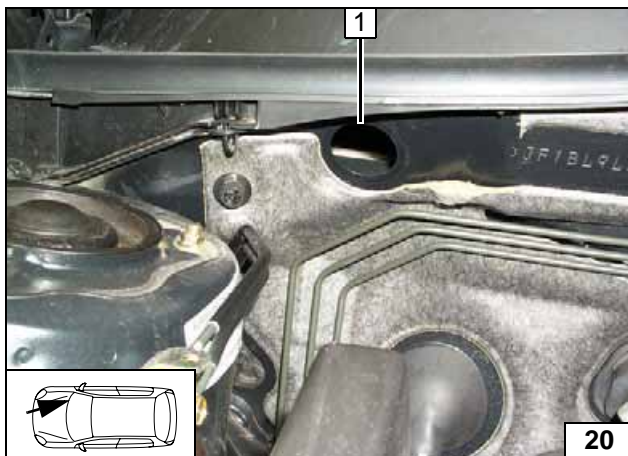

- 1 Hole for protective rubber plug

Removing rubber grommet

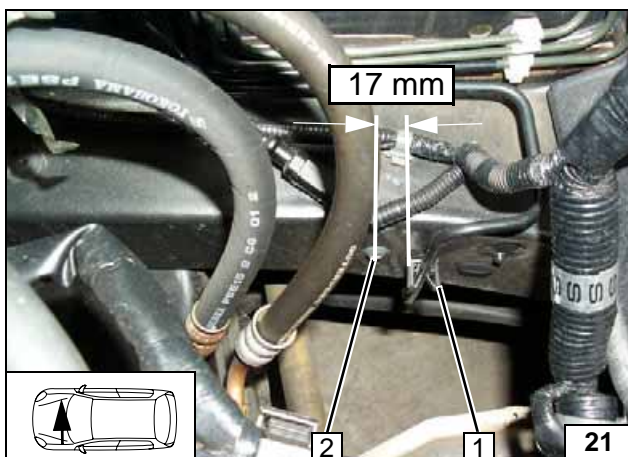

Remove protective rubber plug from hole 2. If hole is not present, drill new hole next to retaining clip for brake line 1.

- 2 Drill 9.1 mm dia. hole; install rivet nut



Installing rivet nut

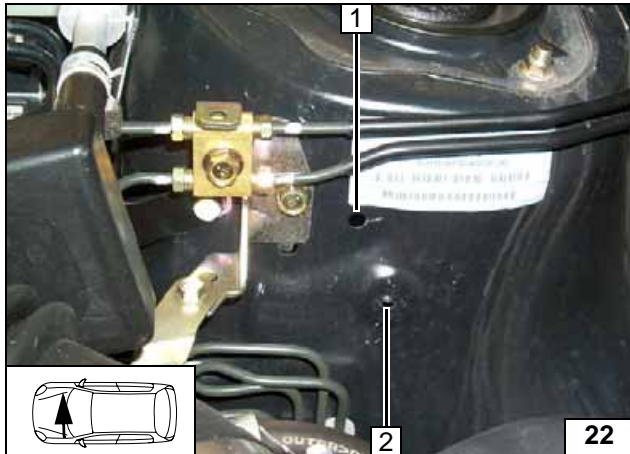
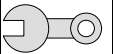

- 1 Original vehicle hole
- 2 7 mm dia. hole

Hole in wheel well

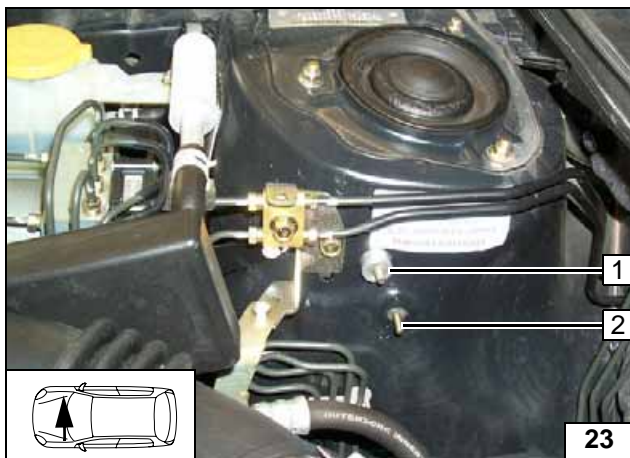

- 1 M6x30 bolt, large diameter washer, 10 mm shim, pin lock
- 2 M6x20 bolt, large diameter washer, pin lock

Mounting bolts



Loosely mount and align heater unit and strut. Check the position of the components; adjust if necessary. Check that they have free clearance.

- 1 Copy hole pattern
- 2 Strut
- 3 M6 flanged nut [2x]

Copying hole pattern to strut



Check line routing and correct if necessary. Ensure sufficient spacing (at least 20 mm) between heater unit and steering line 1.

Checking line routing

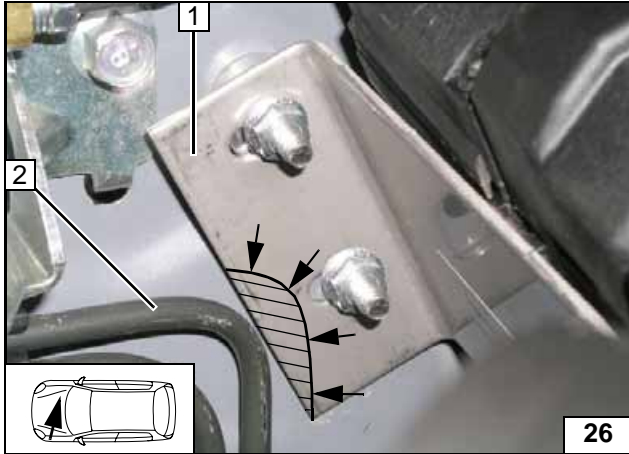
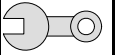

Ensure sufficient spacing (at least 5 mm) between bracket **1** and brake line **2**. Cut out bracket **1** along marking if necessary. Remove heater unit.



Cutting out bracket

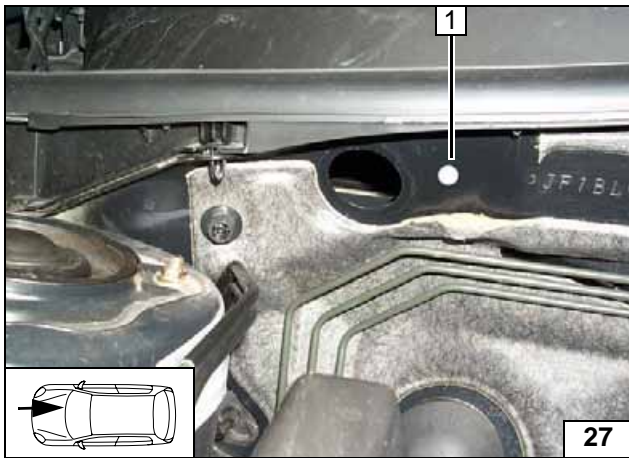

1 7 mm dia. hole

Hole in coolant reservoir

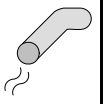

Exhaust system with manual transmission

- 1 Exhaust muffler
- 2 Angle bracket, M6x20 bolt, flanged nut
- 3 M6x20 bolt, spring lockwasher

Installing exhaust muffler

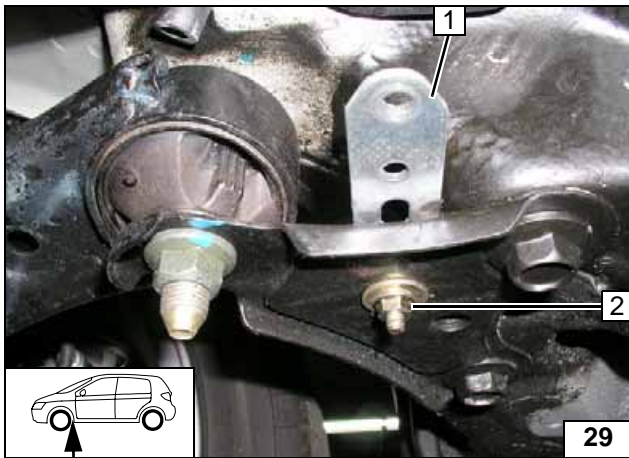

- 1 Perforated bracket
- 2 M6x20 bolt, large diameter washer, M6 flanged nut

Installing perforated bracket

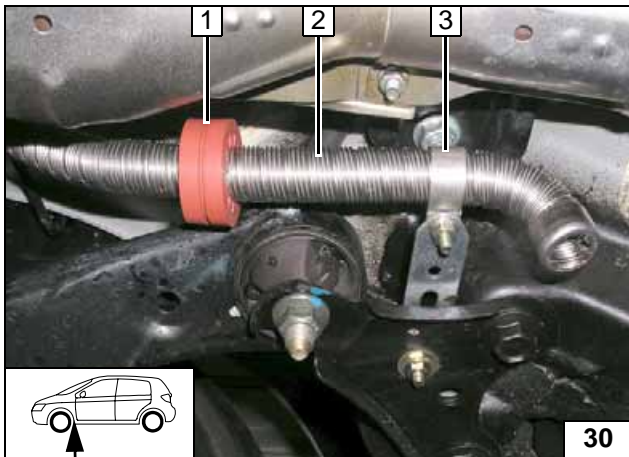

- 1 Red (rt) rubber isolator with groove
- 2 Exhaust end section
- 3 25 mm dia. p-clamp, M6x20 bolt, flanged nut

Installing exhaust end section



Ensure sufficient distance to neighboring components. Position rubber isolator.



Aligning exhaust pipe

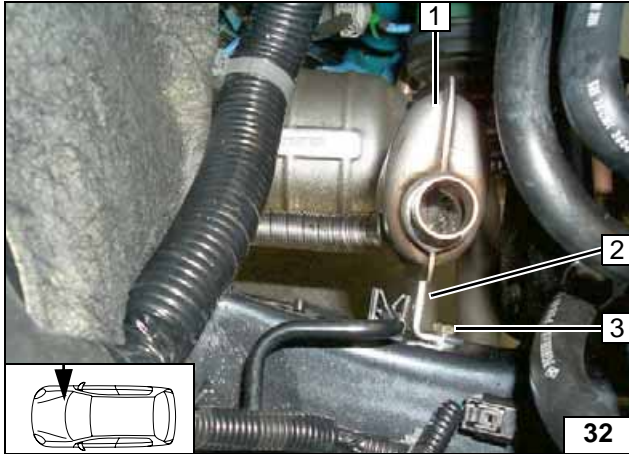
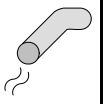

Exhaust system with automatic transmission

- 1 Exhaust muffler
- 2 Angle bracket, M6x20 bolt, flanged nut
- 3 M6x20 bolt, spring lockwasher

Installing exhaust muffler

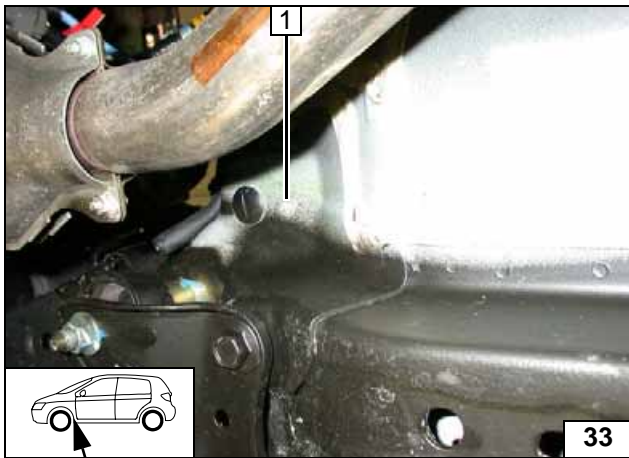

- 1 Drill 9.1 mm dia. hole; install rivet nut

Installing rivet nut

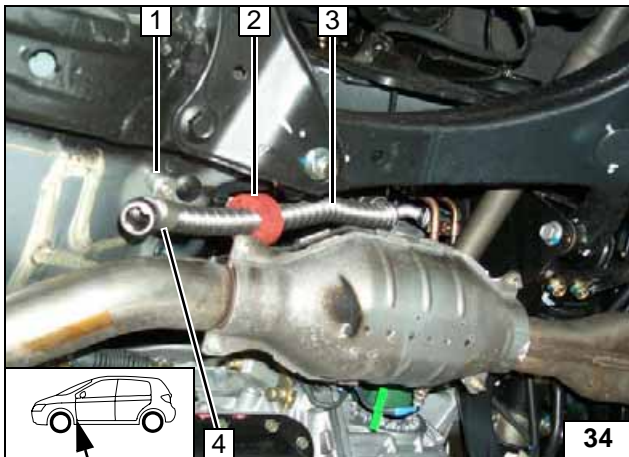

- 1 20 mm spacer
- 2 Red (rt) rubber isolator with groove
- 3 Exhaust end section
- 4 25 mm dia. p-clamp, M6x40 bolt, spring lockwasher

Installing exhaust end section



Ensure sufficient distance to neighboring components. Position rubber isolator.



Aligning exhaust pipe

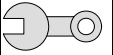

Installing heater unit

Connect exhaust pipe before installing heater unit on muffler.
Align heater unit. Ensure sufficient distance to neighboring components. Tighten Eject screws; tightening torque 10 Nm.

- 1 M6x20 bolt, large diameter washer, flanged nut
- 2 M6 flanged nut [2x]

Installing heater unit

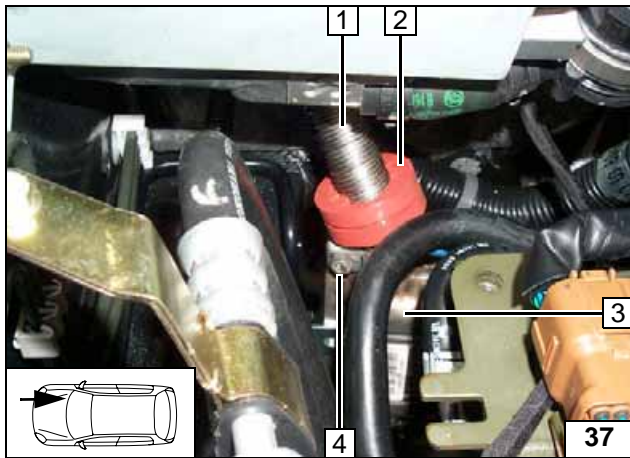

- 1 Exhaust pipe
- 2 Red (rt) rubber isolator with groove
- 3 Exhaust muffler
- 4 Hose clamp

Installing exhaust pipe on heater unit

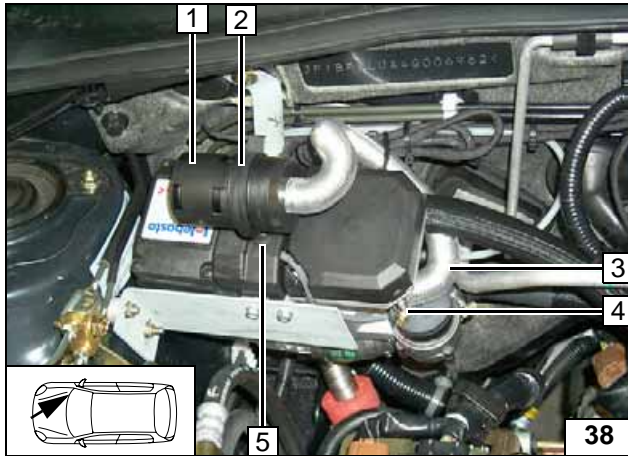

Combustion air

- 1 Combustion-air intake muffler
- 2 Retaining clip in hole
- 3 Combustion-air intake pipe
- 4 27 mm dia. hose clamp
- 5 Hole

**Installing
combustion
air
pipe**



Coolant connection

WARNING!

Tighten all hose clamps to 2.0 + 0.5 Nm.

Any coolant running off should be collected using an appropriate container.

Install hoses so that they are kink-free. Unless specified otherwise, always fasten using cable ties.

Position hose clamps and spring band clamps so that no other hose can be damaged.

The connection should be "inline" based on the following diagram:

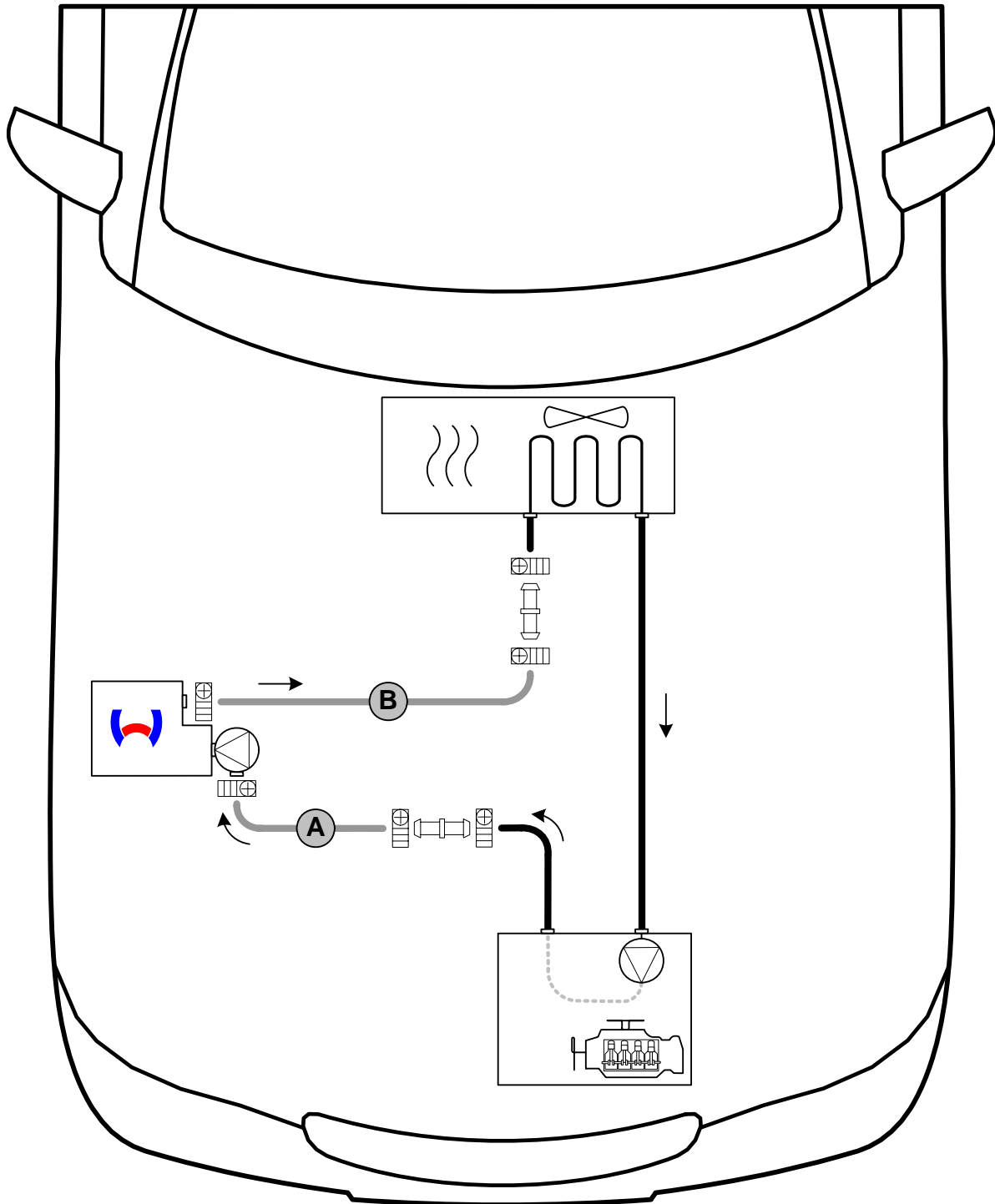

Coolant routing diagram

All clamps without a specific designation = 20-27 mm dia. hose clamps!
 All connecting pipes = 15x20 dia..



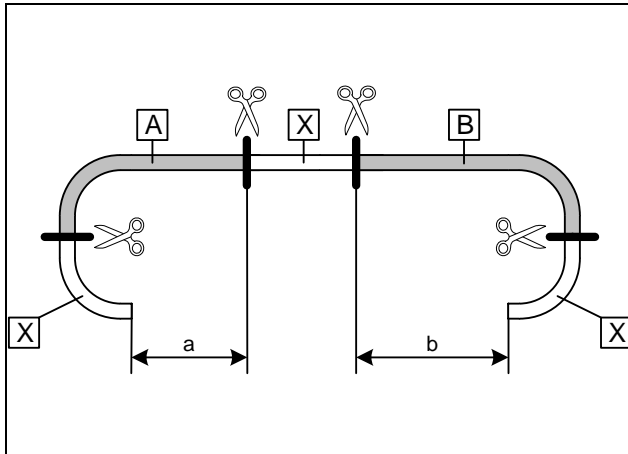

a = 330 mm
b = 430 mm

Discard section **X**

Cutting coolant hoses to length

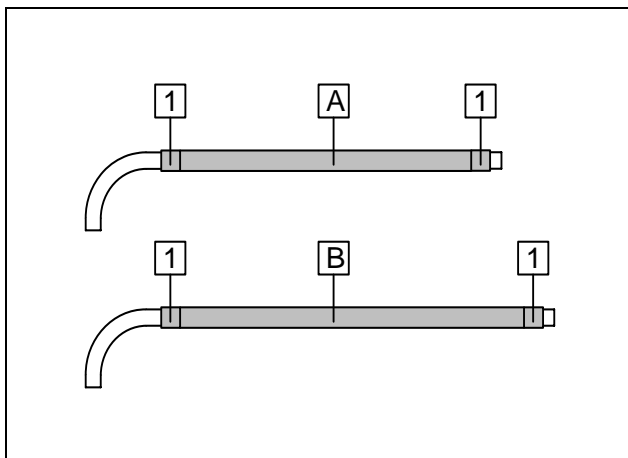

Push braided protection hoses onto hose **A** and **B** and cut to length.
Cut heat shrink plastic tubing to length.



1 25 mm heat shrink plastic tubing [4x]

Preparing coolant hoses

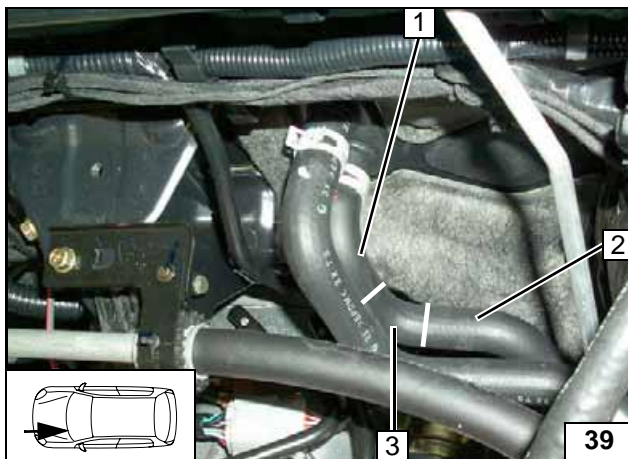

- 1** Original vehicle hose on heater exchanger inlet
- 2** Original vehicle hose on engine outlet
- 3** Discard hose section

Cutting point



Mounting connection pipes

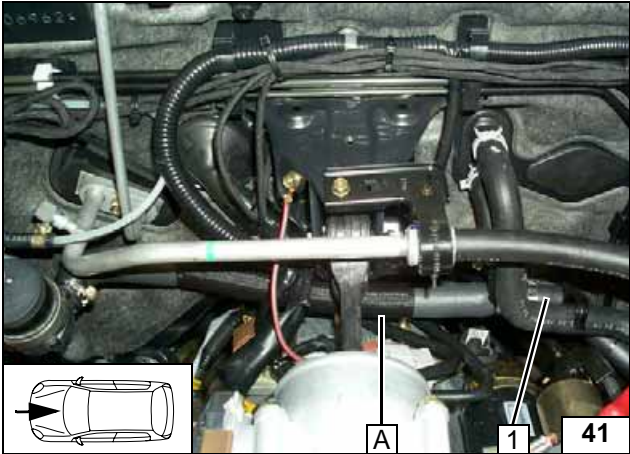

1 Original vehicle hose on engine outlet

Con-
nec-
tion to
heater unit
inlet

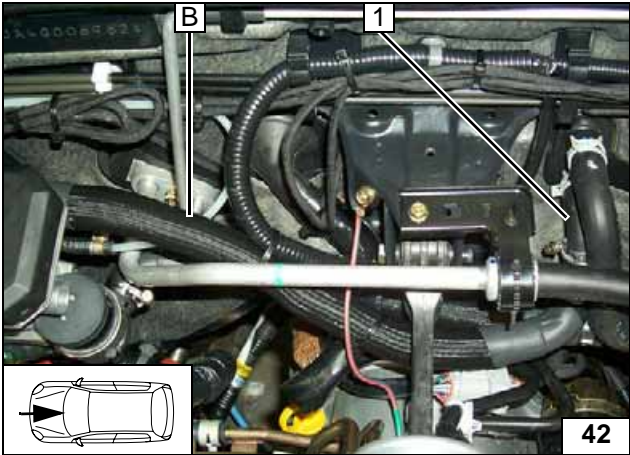

Before connecting, fill the coolant hoses with coolant.



1 Original vehicle hose on heat exchanger inlet

Con-
nec-
tion to
heater unit
outlet



Fuel Connection

CAUTION!

Open the vehicle's fuel tank cap, ventilate the tank and then re-close the tank lock.

Catch any fuel running off with an appropriate container.

Install fuel line and metering-pump wiring harness so that they are protected against stone impact. Unless specified otherwise, always fasten using cable ties.

Mount the fuel line and wiring harness with rub protection on sharp edges.

WARNING!

The fuel line and wiring harness are routed to the metering pump in as shown in the wiring harness routing diagram.

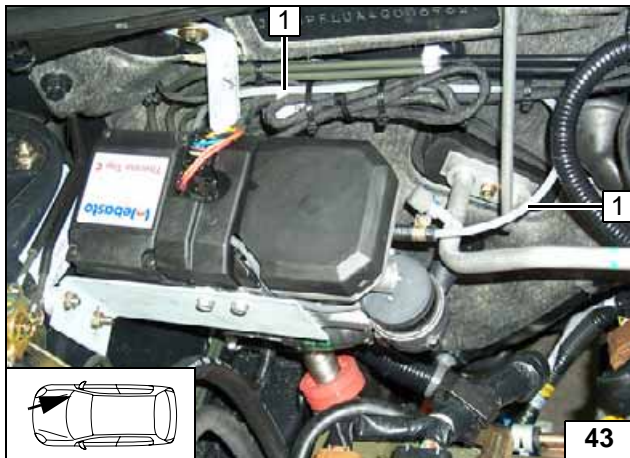

1 Mecanyl fuel line

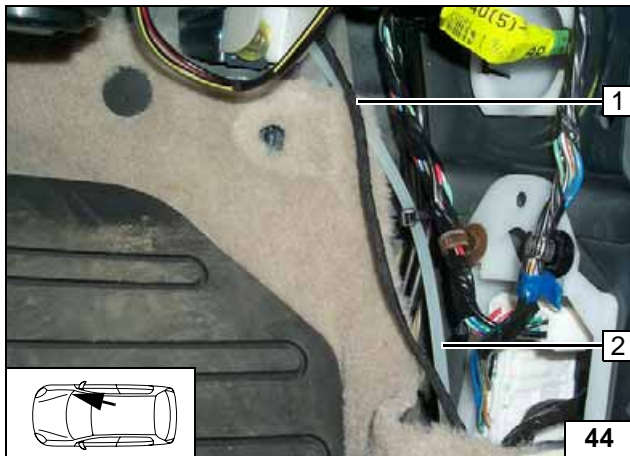

Route under door sill cover toward rear.

1 Metering pump wiring harness
2 Mecanyl fuel line

Connect-
ing fuel
line on
heater unit



Routing
lines in
passenger
compartment

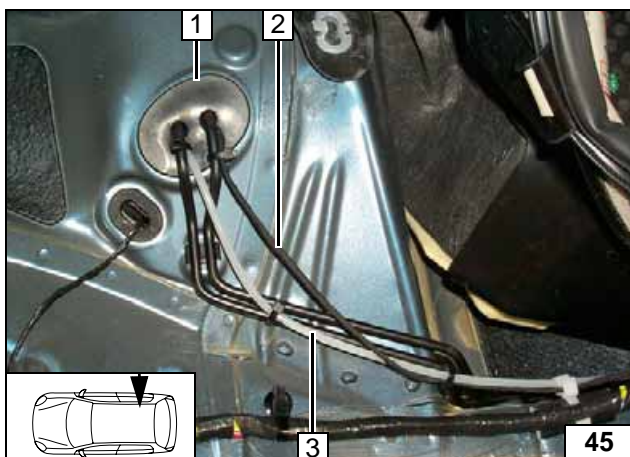

1 Protective rubber plug
2 Metering pump wiring harness
3 Mecanyl fuel line

Installing
lines to
underbody

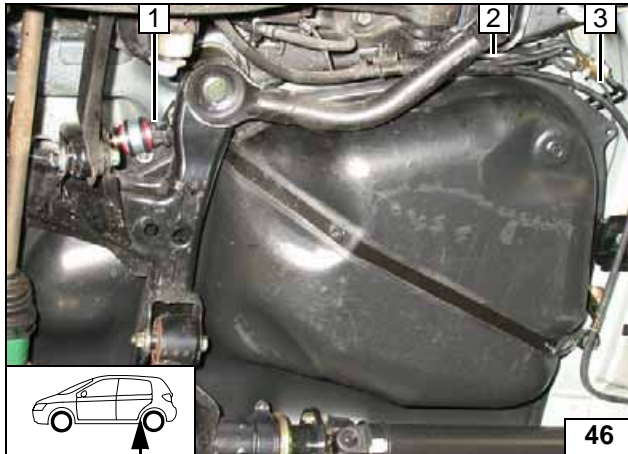

Installation location behind vehicle fuel tank!

- 1 Metering pump
- 2 Mecanyl fuel line from heater unit
- 3 Metering pump wiring harness



Installation location of metering pump

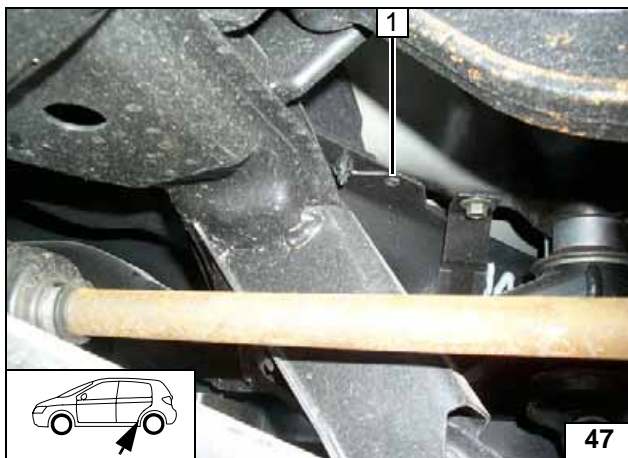

1 Existing hole

Mounting metering pump

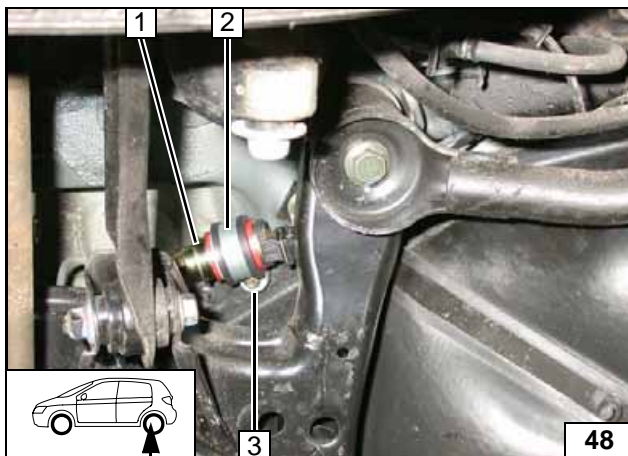

Ensure proper installation position of metering pump, see "Installation Instructions".

- 1 Metering pump
- 2 Rubber-coated pipe clamp
- 3 Silent block, flanged nut [2x]



Installing metering pump

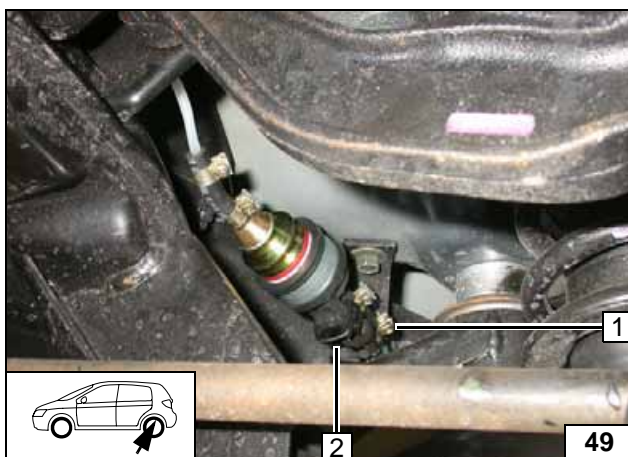

Fuel line from heater unit on pressure side of metering pump [side with connector].

- 1 Hose section, 10 mm dia. hose clamps [2x]
- 2 Wiring harness of metering pump, single-wire seal, tab connector, connector housing



Connecting metering pump

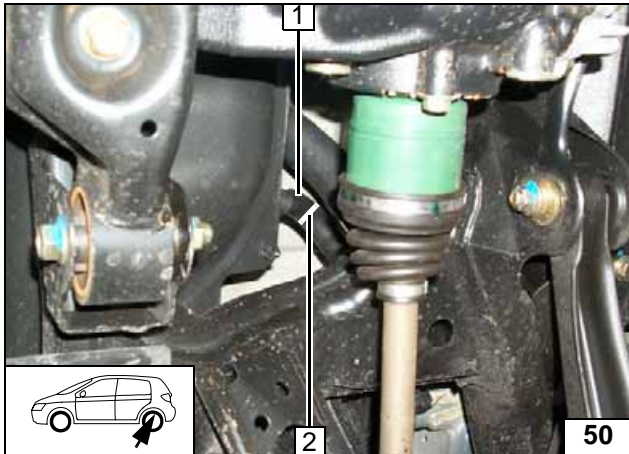

Cut off tank ventilation line at marking as shown.

- 1 Ventilation line
- 2 Cutting point



Cutting point

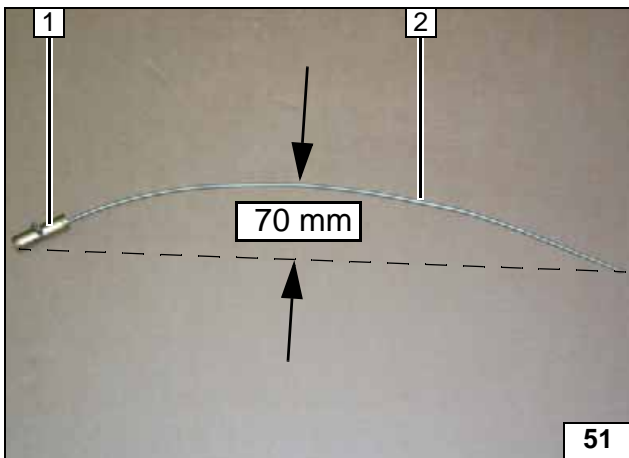

Bend fuel standpipe, but do not shorten. Ensure correct position of standpipe.

- 1 Standpipe
- 2 Fuel standpipe



Bending fuel standpipe

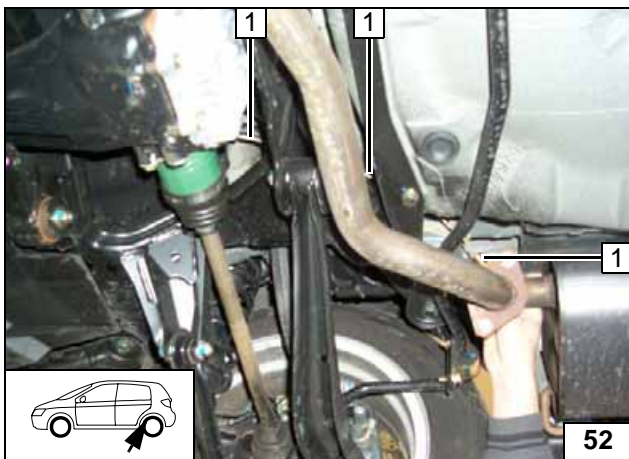

Route fuel standpipe into vent line via rear axle.

- 1 Fuel standpipe



Installing fuel standpipe

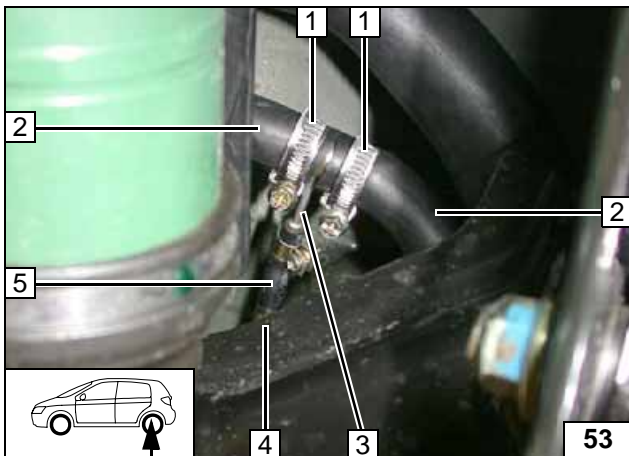

Align fuel standpipe relative to bottom of fuel tank.

- 1 24 mm dia. hose clamp [2x]
- 2 Fuel-tank vent line disconnected
- 3 Standpipe
- 4 Remaining piece of Mecanyl fuel line (covered)
- 5 Dia.3.5 x 4.5 mm hose section, 8 mm dia. hose clamp, 10 mm dia. hose clamp



Installing fuel standpipe

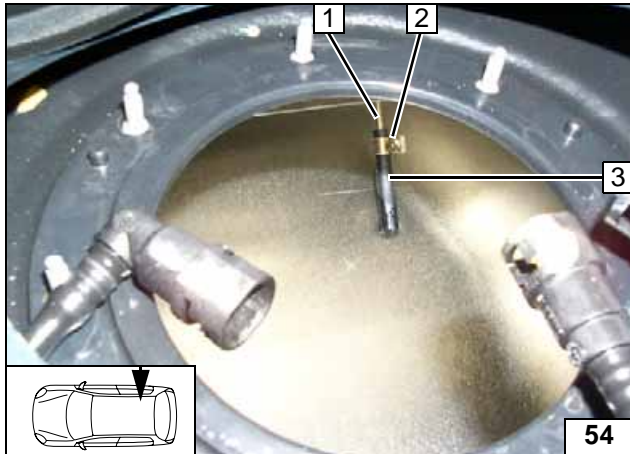

Remove fuel-tank sending unit in accordance with manufacturer's instructions. Align end of standpipe, 5-7mm, to bottom of fuel tank.

- 1 Fuel standpipe
- 2 8 mm dia. hose clamp
- 3 Hose section



Installing hose section

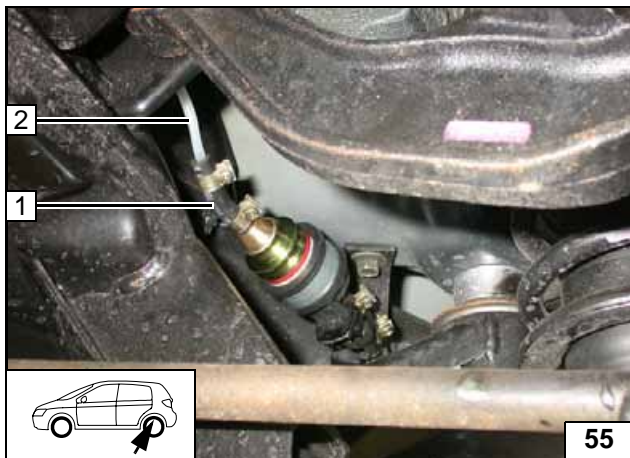

Fuel line from fuel standpipe on intake side of metering pump [side without connector]. Check the position of the components; adjust if necessary. Check that they have free clearance.

- 1 Hose section, 10 mm dia. hose clamps [2x]
- 2 Mecanyl fuel line from fuel standpipe



Connection to metering pump

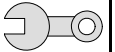

Final Work

WARNING!

Reassemble the disassembled components in reverse order.

Check all hoses, clamps and all electrical connections for firm seating.

Secure all loose cables using cable ties.

Only use manufacturer-approved coolant.

Spray the heater unit components with anti-corrosion wax (Tectyl 100K, Order No. 111329).

- Connect the battery
- Fill and bleed the coolant circuit according to the vehicle manufacturer's specifications.
- Set the digital timer.
- Make the settings for the automatic air-conditioning in accordance with "Operating Instructions for End Customer"
- Check the proper operation of the additional heater, see the operating instructions/installation instructions.
- Attach the "Switch off additional heater before refueling" sticker to the left-hand B-pillar.



Webasto AG
Postfach 80 - 82132 Stockdorf
Hotline 01805 / 932278 - Hotfax 0395 / 5592-353
<http://www.webasto.de>

Operating Instructions for End Customer



Please remove page and add to the vehicle operating instructions.



Note:

We recommend matching the heating time to the driving time.

Heating time = driving time

Example:

For a driving time of approx. 20 min. (in one direction), we recommend not exceeding a switch-on time of 20 min.

If the summer/winter switch option has been installed, this must be switched in accordance with the time of year. The heater unit will then only switch on the vehicle fan to ventilate the vehicle interior in the position Winter  heat and in the position Summer .



Before parking the vehicle, make the following settings:



- 1 Temperature to "max." (32°C.)
- 2 Air outlet to windshield
- 3 Set fan to level "1", or possibly "2"

Single-zone automatic air-conditioning



- 1 Temperature on right and left to "max." (29°C.)
- 2 Air outlet to windshield
- 3 Set fan to level "1", or possibly "2"

Two-zone automatic air-conditioning