

Water Heater Unit



Thermo Top E Additional Heater e1 00 0003

Thermo Top C Additional Heater e1 00 0002

Thermo Top P Additional Heater e1 00 0104

Installation Instructions

Mitsubishi Outlander

2.2 liter Diesel

from Model Year 2007

Left-hand drive vehicle

Automatic air-conditioning!

Manual transmission!



WARNING!

Hazard warning:

Incorrect installation or repair of Webasto heating systems may cause a fire or result in the emission of carbon monoxide, which can be fatal. Serious or fatal injuries can be caused as a result.

Specialist company training, technical documentation, specialized tools and equipment are required to install and repair Webasto heating and cooling systems.

NEVER attempt to install or repair Webasto heating or cooling systems if you have not successfully completed the company training and thereby acquired the required technical skills, or if you do not have access to the required technical documentation, tools and equipment needed to carry out correct installation and repairs.

ALWAYS follow all Webasto installation and repair instructions and observe all warnings.

Webasto does not accept any liability for defects and damage that are attributable to installation by untrained staff.

Table of Contents

Validity	2	Preparing heater unit	12
Heater Unit/Installation Kit	3	Preparing installation location	12
Foreword	3	Installing heater unit	13
General Instructions	3	Coolant connection	14
Special Tools	3	Fuel Connection	19
Explanatory Notes on Document	4	Exhaust system	22
Preliminary Work	5	Combustion air	24
Heater unit installation location	5	Final Work	25
Preparing electrical system	6	Operating Instructions for End Customer	26
Electrical Connections	7	Template for Fuel Standpipe	27
Fan controller	8		
Remote option (Telestart)	10		
Remote option (Thermo Call)	11		

Validity

Manufacturer	Model	Type	EG-BE No./ABE
Mitsubishi	Outlander	CW7W	e1 * 2001/116 * 0406 * ...

Engine type	Engine model	Output in kW	Displacement in cm ³
4HN	Diesel	115	2179

Vehicle and engine types, equipment variants and national specifications not listed in these installation instructions have not been tested. However, installation according to these installation instructions may be possible.

The installation location of a digital timer and summer/winter switch should be confirmed with the end customer before installation.

Heater Unit/Installation Kit

Quantity	Description	Order No.:
1	Retail accessories with desired heater control	See price list
1	Installation kit for Mitsubishi Outlander 2.2 liter Diesel	1313255A

Heater unit recommended for the respective vehicle class:

Vehicle	Heater unit
Compact car	Thermo Top E
Mid-size car, station wagon	Thermo Top C
Full-size car, van, offroader	Thermo Top P

The selection of the heater unit is based on the passenger compartment size of the vehicle and the level of comfort required by the customer!



Foreword

These installation instructions apply to Mitsubishi Outlander 2.2 liter Diesel vehicles - for validity, see page 2 - from model year 2007 and later, assuming technical modifications to the vehicle do not affect installation, any liability claims excluded. Depending on the vehicle version and equipment, modifications may be necessary during installation with respect to these installation instructions.

However, the stipulations in the "installation instructions" and "operating and maintenance instructions" for the *Thermo Top C/P/E* must always be observed.

The corresponding rules of technology and any information from the vehicle manufacturer should be observed during the installation work.

General Instructions

Installation should be carried out according to the general, standard rules of technology. Unless specified otherwise, fasten hoses, lines and wiring harnesses to original vehicle lines and wiring harnesses using cable ties.

Sharp edges should be fitted with edge protectors (split-open plastic hose).

Spray unfinished body areas, e.g. drilled holes, with anti-corrosion wax (Tectyl 100K, Order No. 111329).

Special Tools

- Torque wrench for 2.0 - 10 Nm
- Hose clamping pliers

Explanatory Notes on Document

To provide you with a quick overview of the individual working steps, you will find an identification mark on the outside top right corner of the page in question.

Mechanical system

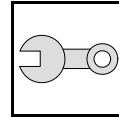

Electrical system

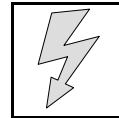

Coolant connection

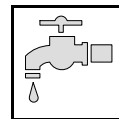

Fuel connection

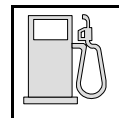

Exhaust system

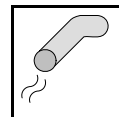

Combustion air

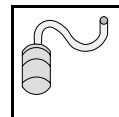

Special features are highlighted using the following symbols:



Specific risk of injury or fatal accidents.



Specific risk of damage to components.



Specific risk of fire or explosion.



Reference to general installation instructions of Webasto components or to the manufacturer's vehicle-specific documents.



Reference to a special technical feature.

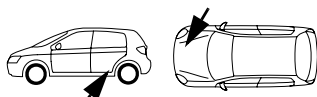

The arrow in the vehicle icon indicates the position on the vehicle and the viewing angle.

Preliminary Work

WARNING!

- Open fuel tank cap, ventilate tank.
- Close the tank cap again.
- Depressurize the cooling system.
- Copy the factory number from the original type label to the duplicate type label.
- Remove years that do not apply from the duplicate label.
- Attach the duplicate label (type label) in the appropriate place.
- Remove the engine cover.
- Completely remove the battery.
- Remove the air filter together with the intake hose.
- Detach the right and left-hand wheel well trim; remove on left
- Remove the bumper.
- Remove the underride protection on the front left
- Remove the left-hand stoneguard in front of the fuel tank (if installed)
- Remove the 3rd seat row (if installed)
- Fold back the floor covering
- Open the tank-fitting service lid.
- Remove the fuel-tank sending unit in accordance with the manufacturers specifications.
- Remove the footwell trim on the driver's and front passenger side
- Remove the instrument panel trim on the driver's side (only with Telestart)

Remove page 26 "Operating Instructions for End Customer" and add to the vehicle operating instructions.

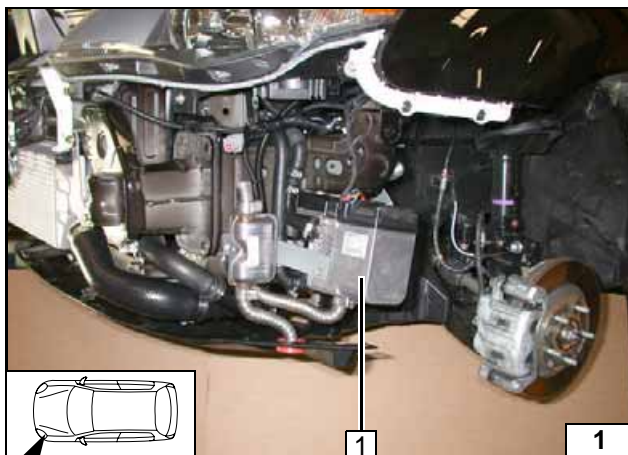

Heater unit installation location

Left front wheel only removed for demonstration purposes!

- 1 Heater unit



Installation location



Preparing electrical system

Wire section 2 will be required later for connecting the IPCU/A!

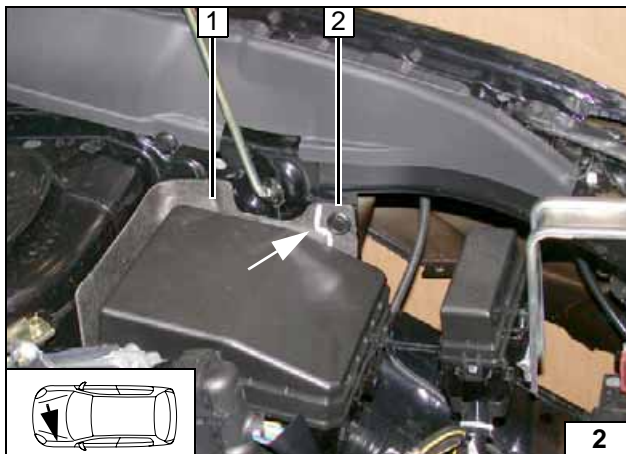
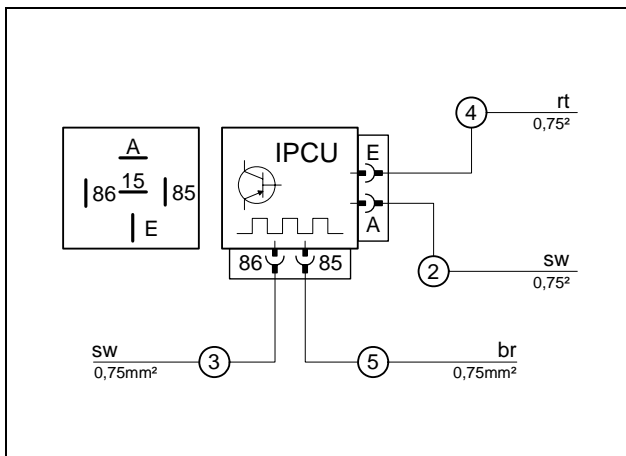
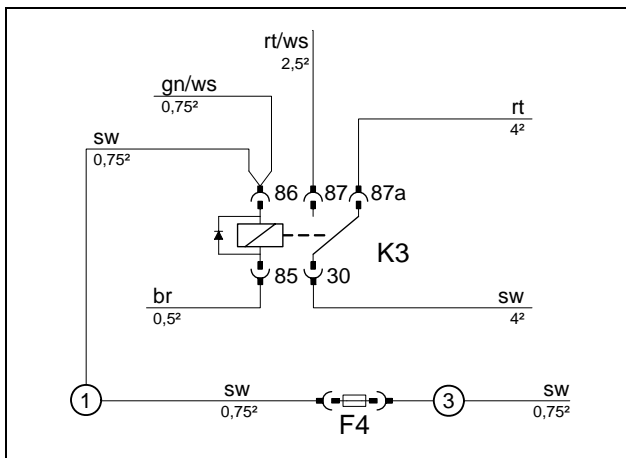
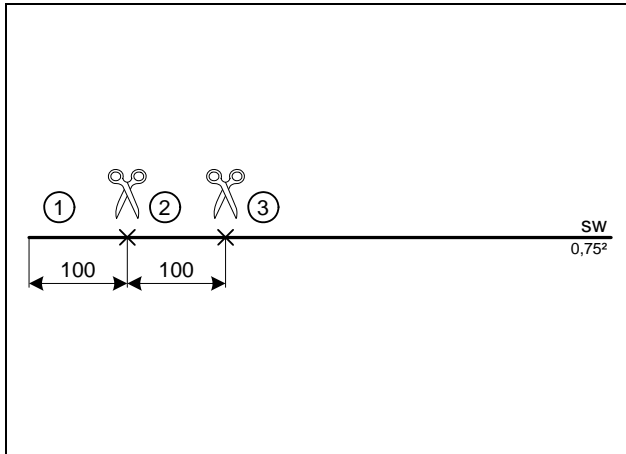

Cutting wires to length



Preparing fuse F4



Preassembling IPCU



Cutting away insulation mat

Produce connections as shown in wiring diagram. Install wire section 3 together with wiring harnesses of fan controller and digital timer in corrugated tube.

Connect wires to IPCU.

Duty cycle: 100 %
Frequency: 14 kHz
Voltage: 4.2 V
Function: High-side

Cut away insulation mat 1 from fuse and relay box at marking. Remove retaining clip 2 and discard.



Electrical Connections

Wiring harness pass through

- 1 Protective rubber plug
- 2 Wiring harnesses of fan controller and digital timer, black (sw) wire from F4

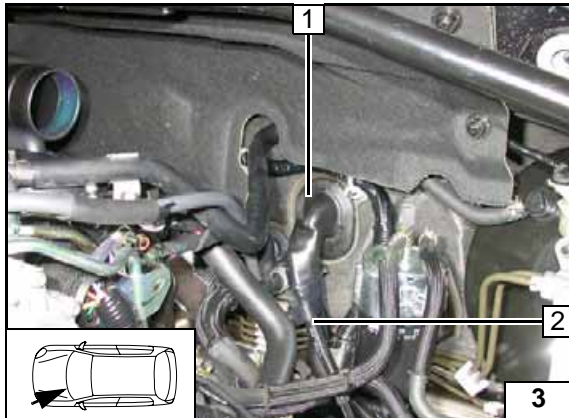

Summer/winter switch option

- 1 Summer/winter switch, drilled hole 12 mm dia.

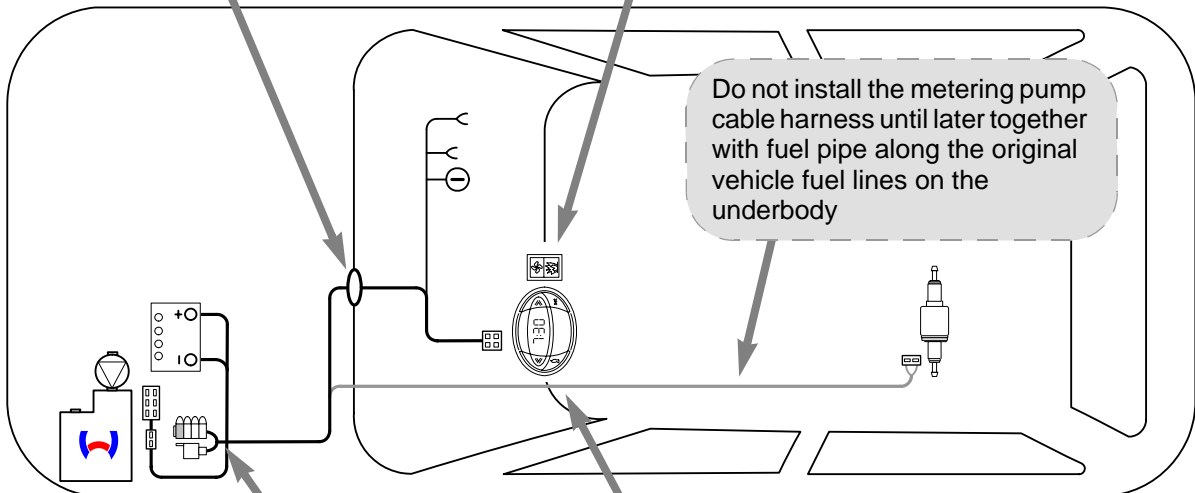

Wiring harness installation diagram

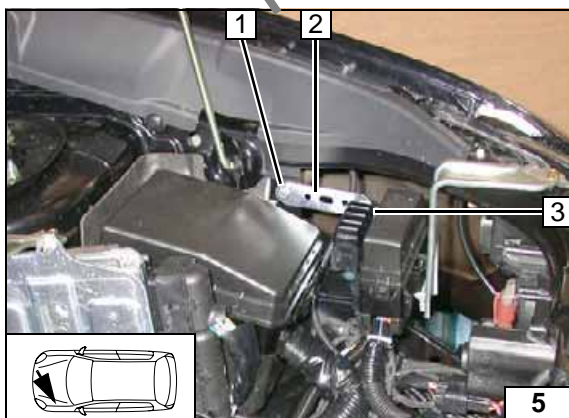

Fuse holder, relay K3

- 1 M6x20 bolt, flanged nut on hole of retaining clip
- 2 Perforated bracket
- 3 Retaining plate of fuse holder, M5x16 bolt, fuse holder [4x], relay K3, washer, flanged nut on perforated bracket



Digital timer

- 1 Digital timer



Fan controller

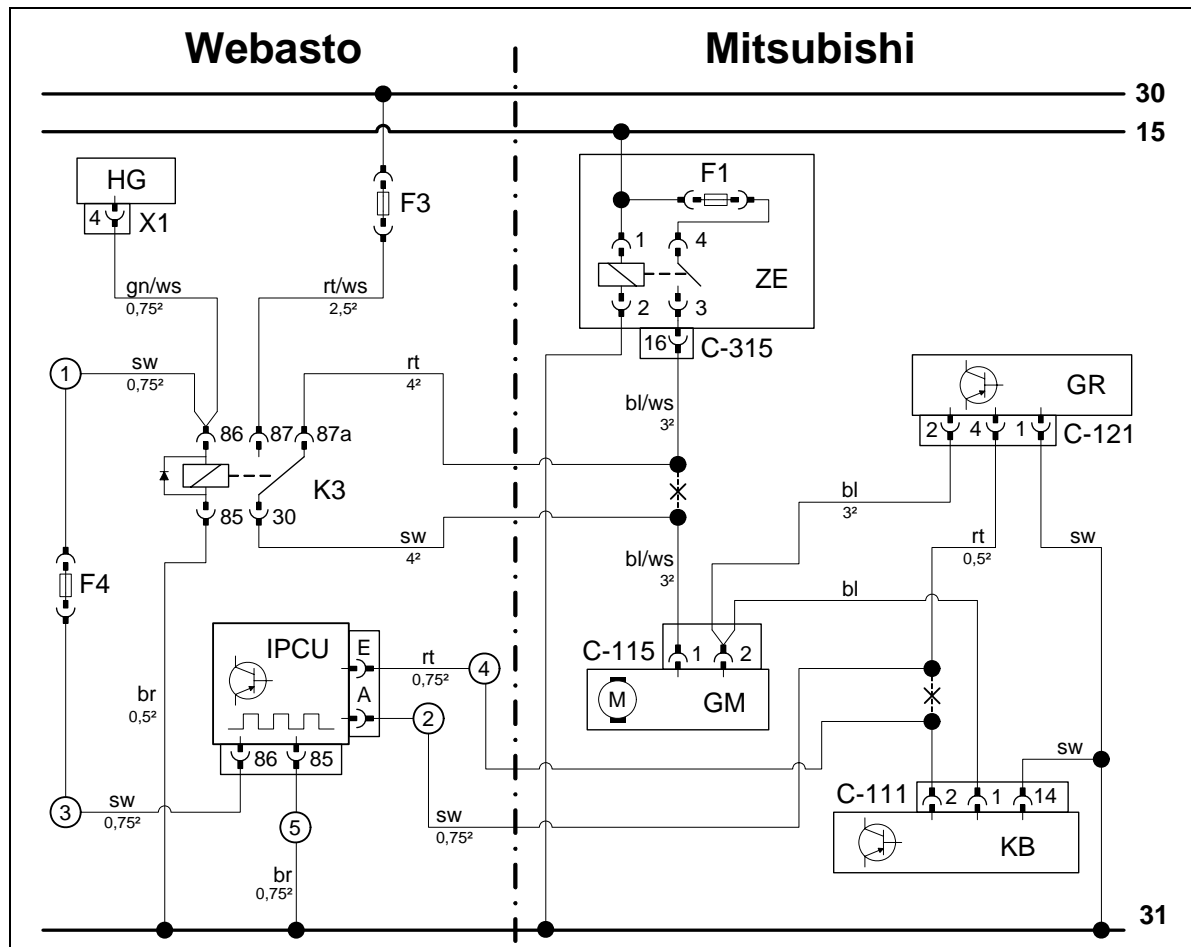

Wiring diagram

Webasto components		Vehicle components		Colors and symbols	
HG	Heater unit TT-C/E	GM	Fan motor	rt	red
X1	6-pin connector	C-115	2-pin connector GM	ws	white
F3	25 A fuse	GR	Fan controller	sw	black
F4	1 A fuse	C-121	4-pin connector GR	br	brown
K3	Fan relay	KB	Air-conditioning control panel	gn	green
IPCU	Pulse width modulator	C-111	20-pin connector KB	bl	blue
IPCU adjustment values:		C-315	19-pin connector ZE		
Duty cycle: 100 %		F1	10 A fuse		
Frequency: 14 kHz					
Voltage: 4.2 V				X	Cutting point
Function: High-side				Wiring colors may vary.	

Legend

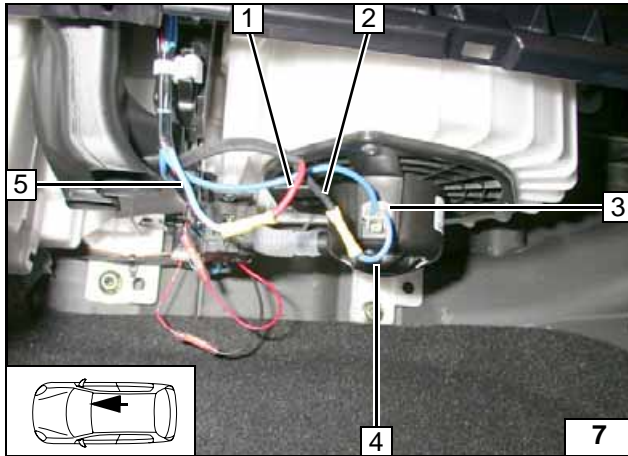
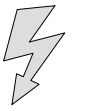

Connection to 2-pin connector C-115 3 from blower motor. Produce connections as shown in wiring diagram.

- 1 Red (rt) wire from K3/87a
- 2 Black (sw) wire from K3/30
- 4 Blue/white (bl/ws) wire of connector C-115
- 5 Blue/white (bl/ws) wire of fan relay in central electrical box

**Connect-
ing fan-mo-
tor**

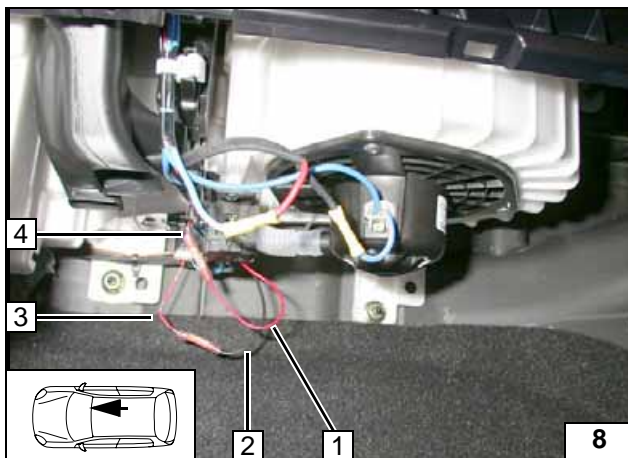

- 1 Red (rt) wire of IPCU/E
- 2 Black (sw) wire of IPCU/A
- 3 Red (rt) wire of fan controller
- 4 Red (rt) wire of A/C control panel

**Connect-
ing IPCU**

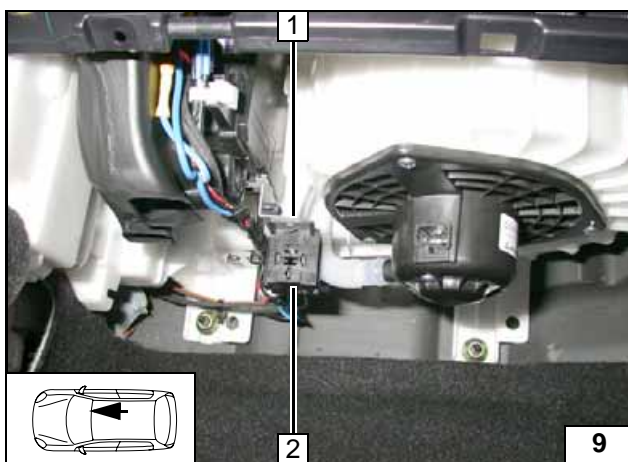

- 1 Original vehicle bolt
- 2 IPCU socket

**Installing
IPCU**

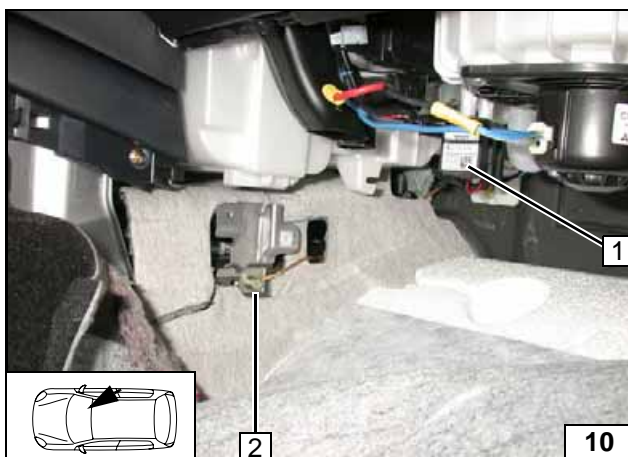

Produce connections as shown in wiring diagram.

- 1 Connect IPCU
- 2 Brown (br) wire of IPCU/85 on original vehicle ground point



**Connect-
ing ground
wire**

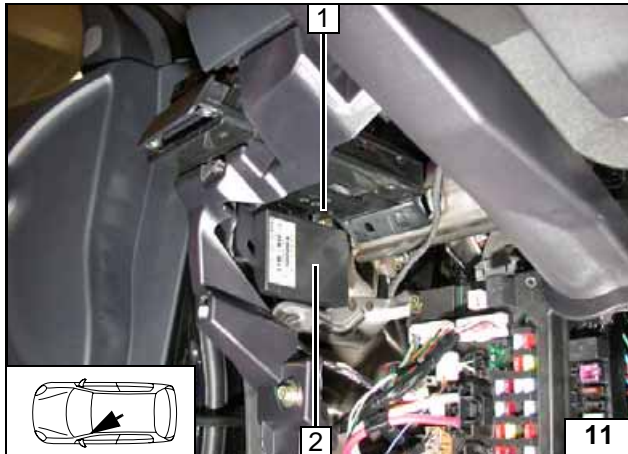

Remote option (Telestart)

- 1 Mount M5x16 bolt, bracket, flanged nut in existing hole
- 2 Receiver



Installing receiver

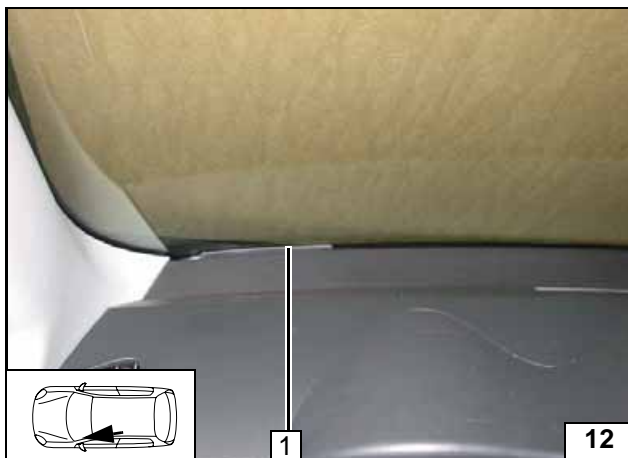

- 1 Antenna

Installing antenna

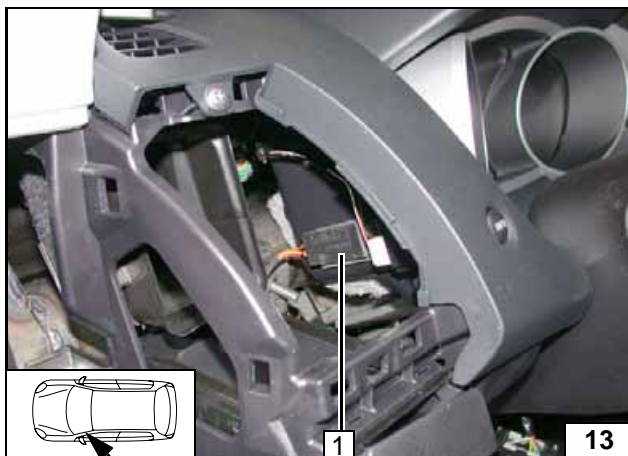

Temperature sensor for HTM100 only

- 1 Fasten temperature sensor with suitable means

Installing temperature sensor

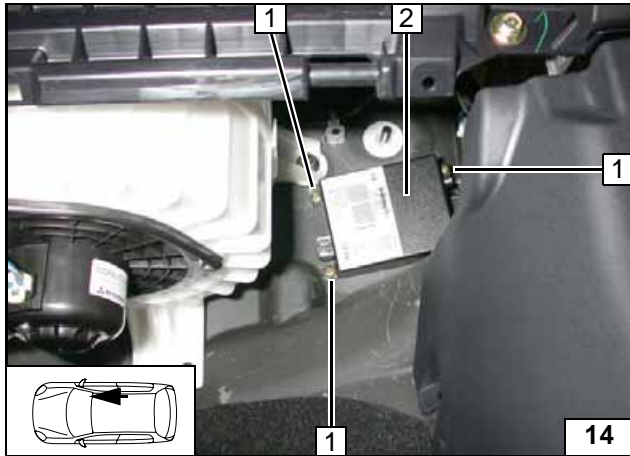

Remote option (Thermo Call)

- 1 5.5x9.5 self-tapping screws [4x]
- 2 Receiver



Installing receiver

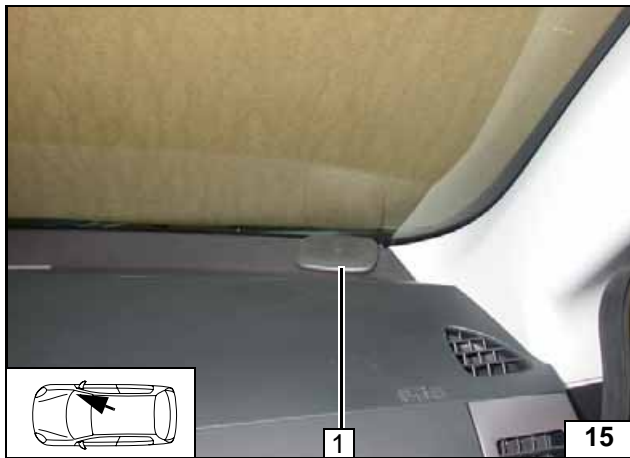

- 1 Antenna

Installing antenna



- 1 Pushbutton

Installing push button

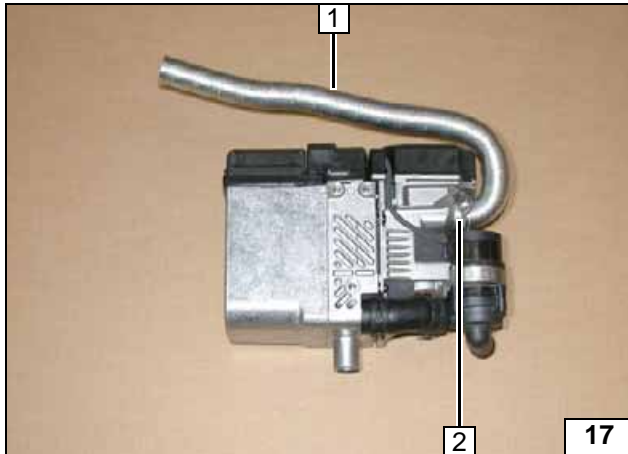
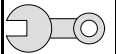

Preparing heater unit

- 1 Combustion-air intake pipe
- 2 27 mm dia. clamp

Premounting intake pipe

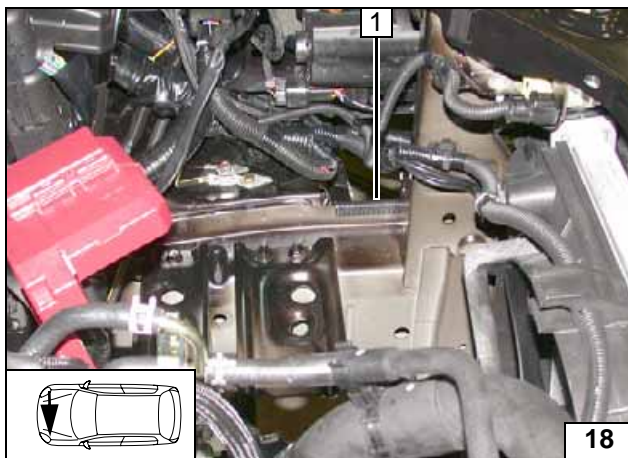

Preparing installation location

- 1 50 mm edge protection

Installing edge protection

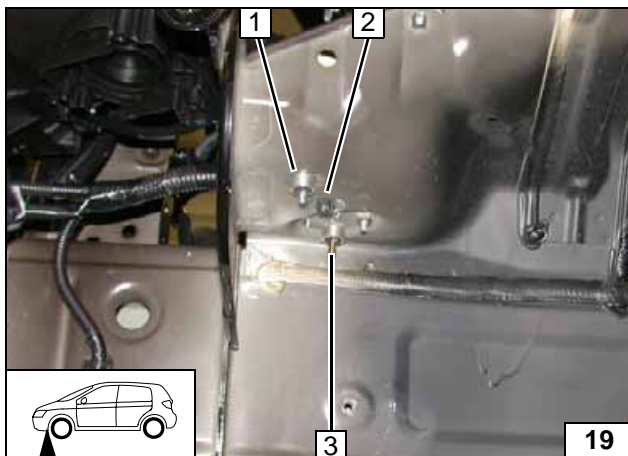

Remove original vehicle retaining clip at position 1 and replace with M6x30 bolt, 8 mm shim and pin lock.

Remove original vehicle bolt at Position 3 and replace with M6x30 bolt, 5 mm shim and pin lock.

- 2 Remove original vehicle clip



Replacing bolts

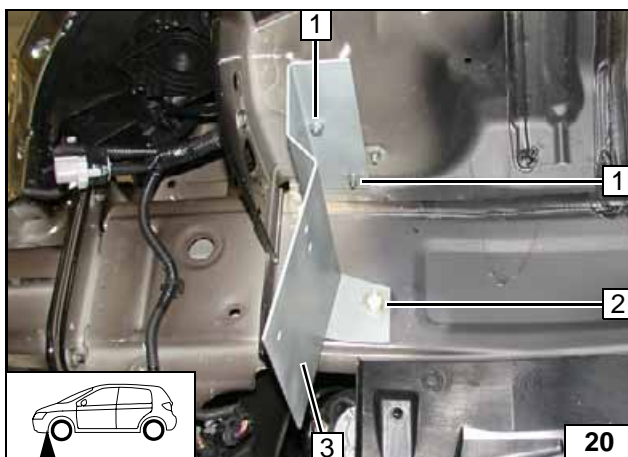

- 1 Flanged nut [2x]
- 2 M8x20 bolt, large diameter washer, spring lockwasher in existing threaded hole
- 3 Bracket

Installing bracket

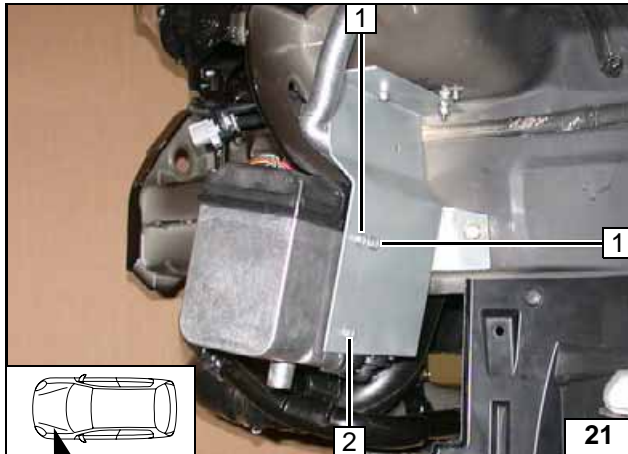

Installing heater unit

Ejot screw bolt, tightening torque 10 Nm!
Insert two washers between heater unit and bracket at Position 2.

- 1 Ejot screw [2x]
- 2 Ejot screw, washer [2x]



Installing heater unit

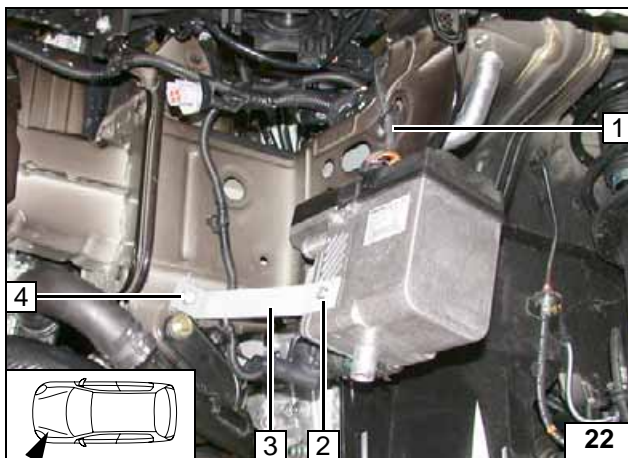

Ejot screw bolt 2, tightening torque 10 Nm.

- 1 Connect wiring harness of heater unit
- 3 Strut
- 4 M8x20 bolt, spring lockwasher in existing threaded hole



Installing strut

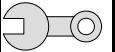

Coolant connection

WARNING!

Tighten hose clamps to 2.0 + 0.5 Nm.
 Any coolant running off should be collected using an appropriate container.
 Install hoses so that they are kink-free. Unless specified otherwise, always fasten using cable ties.
 Position clamps so that no other hose can be damaged!
 The connection should be "inline" based on the following diagram:

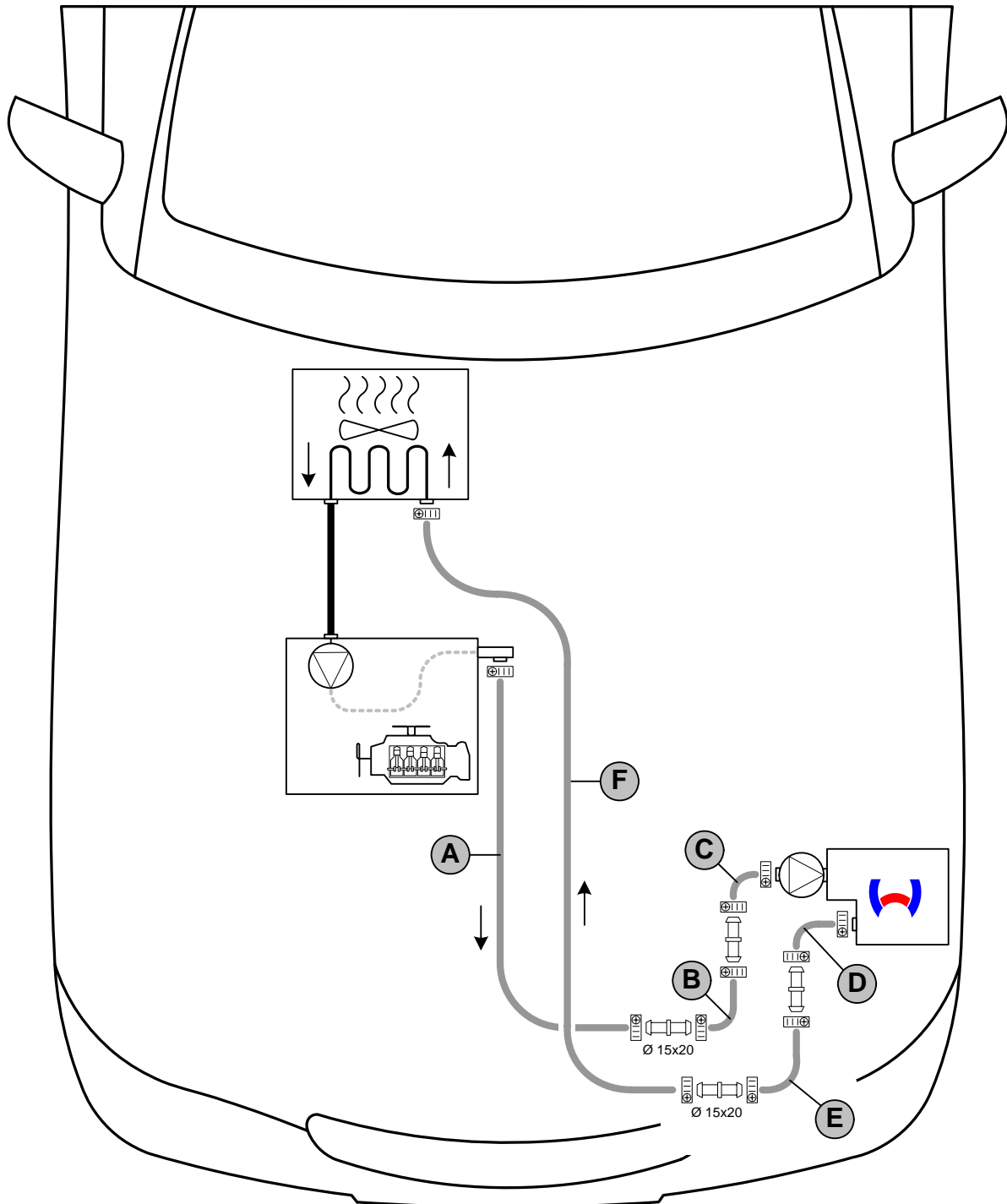

Coolant routing diagram

All connecting pipes = 20x20 dia..
 All hose clamps = 16-27 mm dia.!



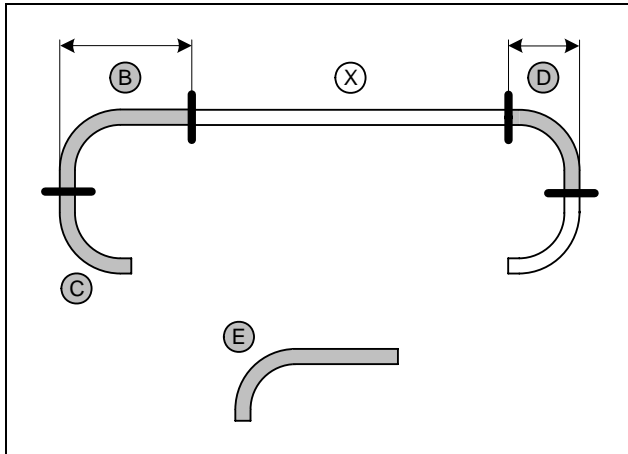
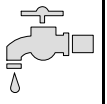

Hose **E** = included molded hose

b = 240 mm
d = 110 mm

Discard section **X**.



Cutting
20 mm dia.
coolant
hoses to
length

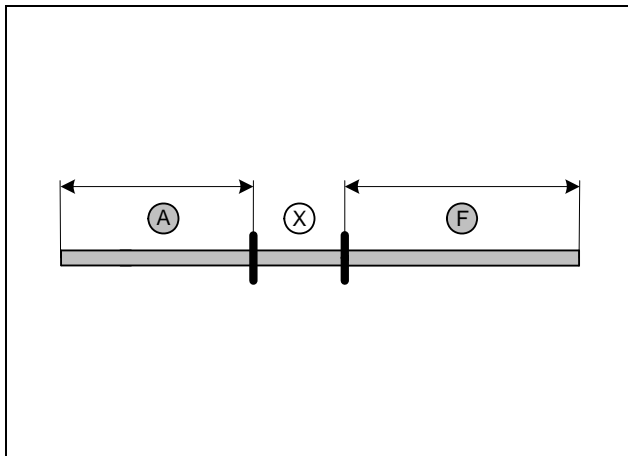

a = 700 mm
f = 1,135 mm

Discard section **X**.

Cutting
15 mm dia.
coolant
hoses to
length

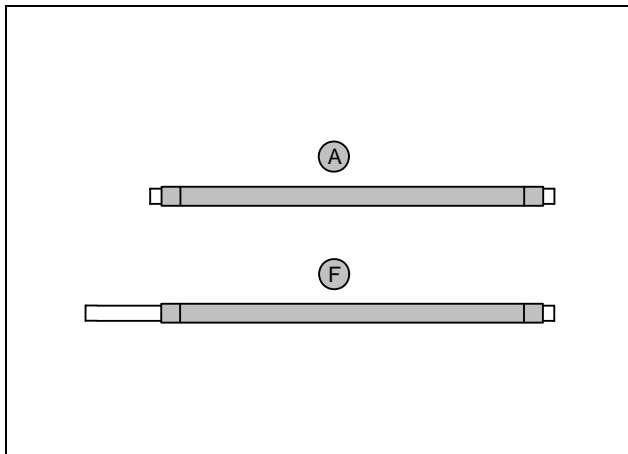

Push braided protection hoses onto hose **A** and **F** and cut to length.
Cut heat shrink plastic tubing to length.

1 25 mm heat shrink plastic tubing [4x]



Preparing
coolant
hoses

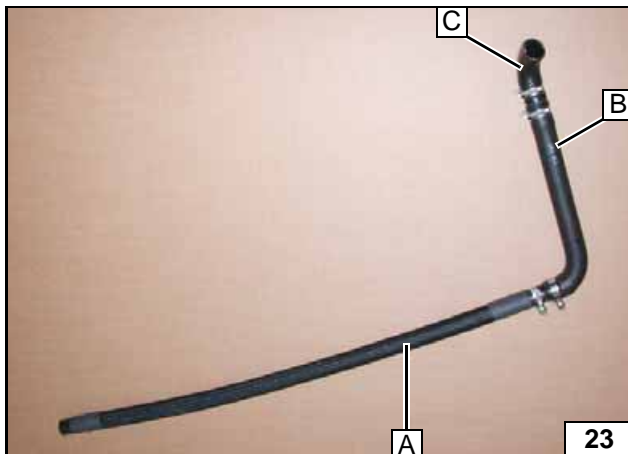

Premounting
hose **A**,
B and **C**

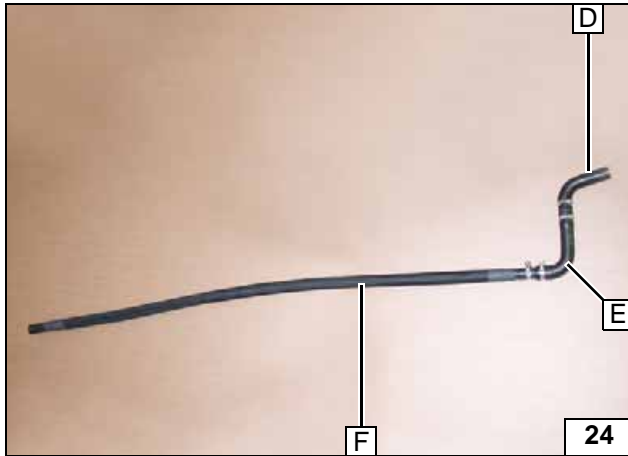
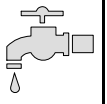

Hose **D** = molded hose with 90° elbow provided.



Premounting hose D, E, F

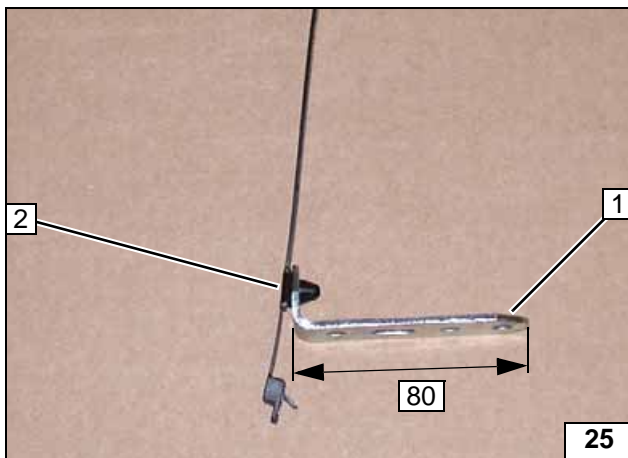

Angle down perforated bracket **1** by 90°. Insert clip-type cable tie **2** in hole.



Preparing perforated bracket

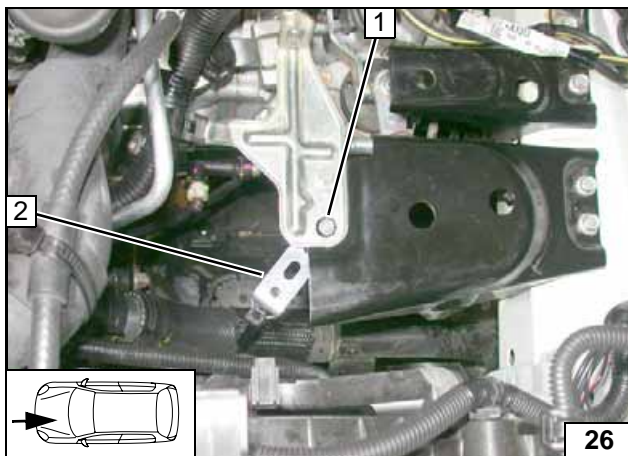

Replace original vehicle bolt at position **1** with M6x25 bolt. Fasten perforated bracket **2** with M6 flanged nut on M6x25 bolt **1**.



Installing perforated bracket

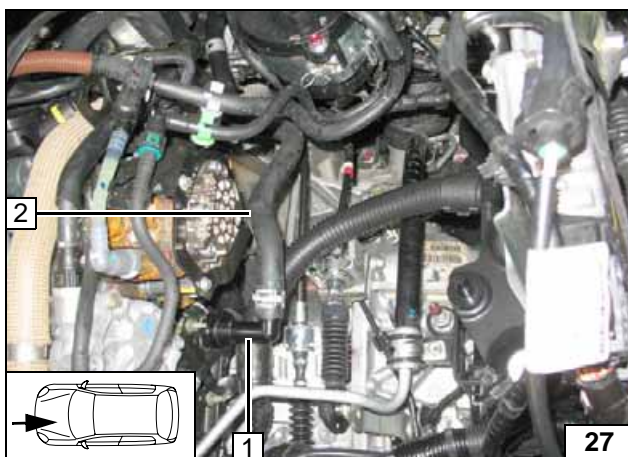

Remove original vehicle hose **2** on engine outlet/heat exchanger inlet and discard. Turn connection piece **1** on engine outlet toward front.



Cutting point

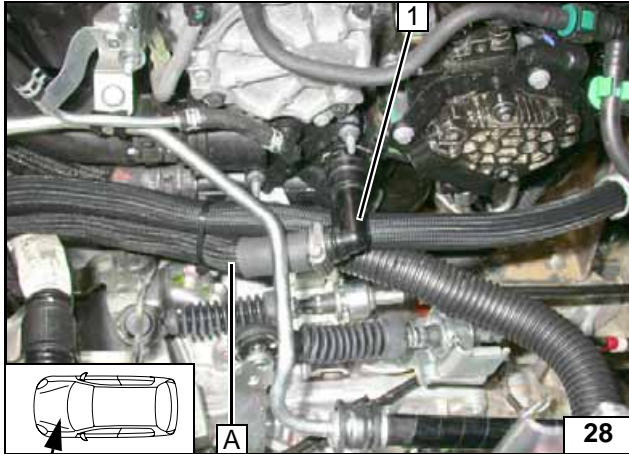

1 Connection piece on engine outlet turned

Connect-
ing engine
outlet

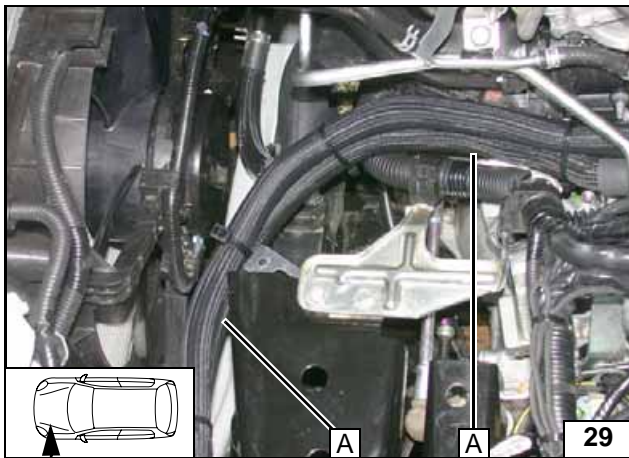

Routing in
engine
compart-
ment



Connect-
ing heater
unit inlet

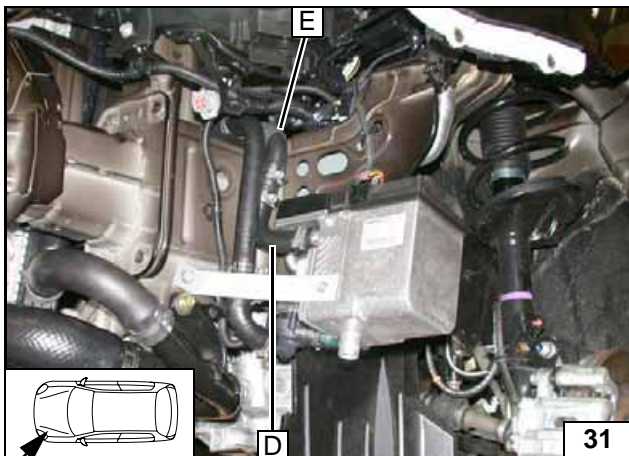

Connect-
ing heater
unit outlet

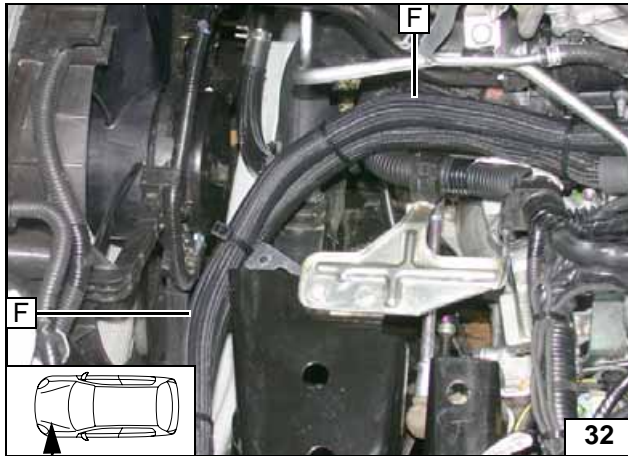

Route premounted hose **F** along hose **A**.



Routing in engine compartment

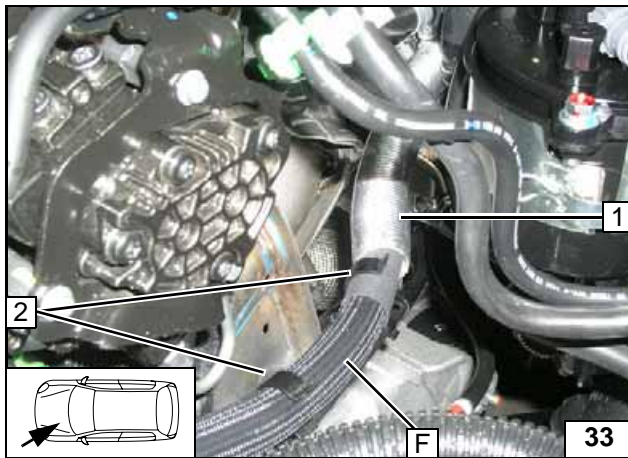

Slide on heat protection hose **1** before installation.



2 Spacer [2x]

Connecting heat exchanger inlet

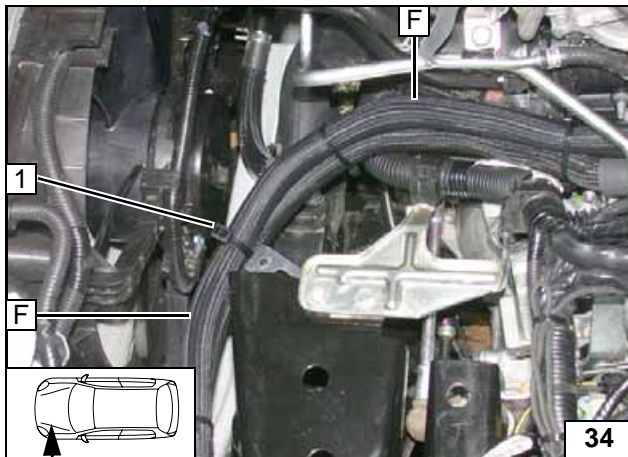

1 Clip-type cable tie

Fastening coolant hose

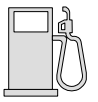

Fuel Connection

CAUTION!

Open the vehicle's fuel tank cap, ventilate the tank and then re-close the tank lock.

Catch any fuel running off with an appropriate container.

Install fuel line and metering-pump wiring harness so that they are protected against stone impact. Unless specified otherwise, always fasten using cable ties. Mount the fuel line and wiring harness with rub protection on sharp edges.

WARNING!

The fuel line and wiring harness are routed to the metering pump in as shown in the wiring harness routing diagram.

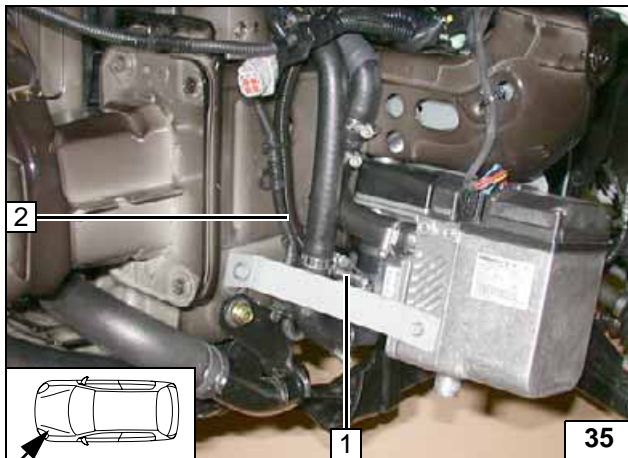

- 1 Hose section, 10 mm dia. hose clamp [2x]
- 2 Fuel line in corrugated tube

Conne-
ction to
heater unit

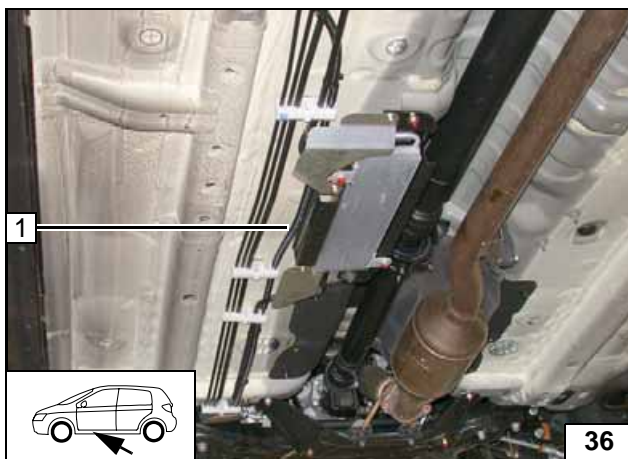

- 1 Fuel line, wiring harness of metering pump in corrugated tube

Installing
lines

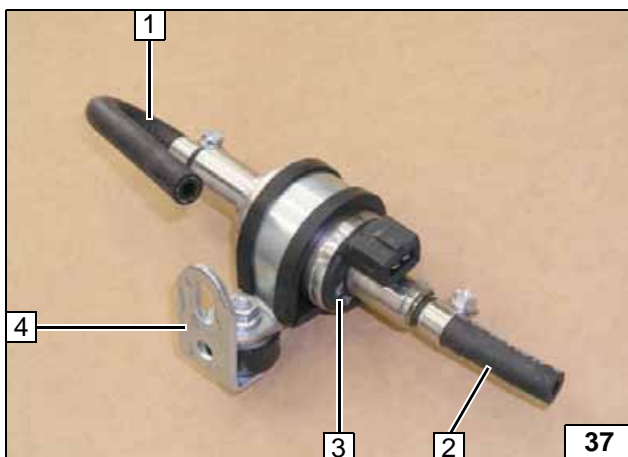

- 1 180° molded hose, 10 mm dia. clamp
- 2 Hose section, 10 mm dia. clamp
- 3 Metering pump
- 4 Rubber-coated p-clamp, silent block, flanged nut [2x] on angle bracket

Premount-
ing meter-
ing pump

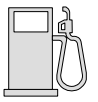

Installation location on left in front of vehicle fuel tank!

- 1 Original vehicle M8 nut



Installing metering pump

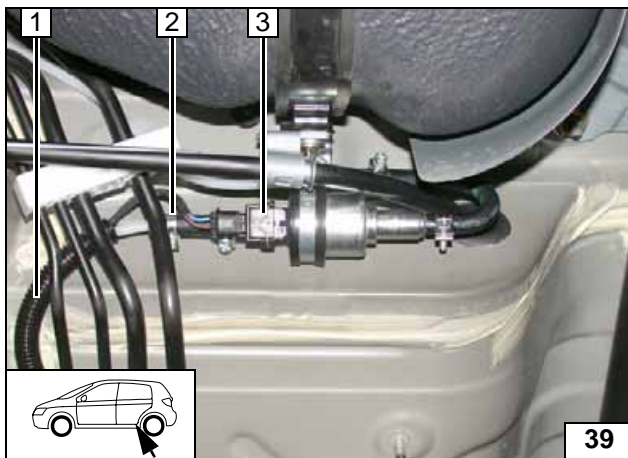

- 1 Fuel line, wiring harness of metering pump in corrugated tube
- 2 10 mm dia. hose clamp
- 3 Wiring harness of metering pump, connector mounted

Connecting to metering pump

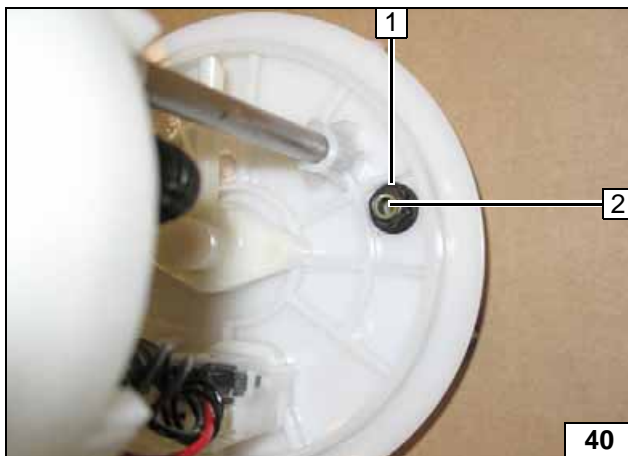

Remove fuel-tank sending unit in accordance with manufacturer's instructions. Ensure correct seating of flange nut of fuel standpipe 1 between ribs while drilling.

- 2 Copy hole pattern, 6 mm dia. hole



Removing fuel

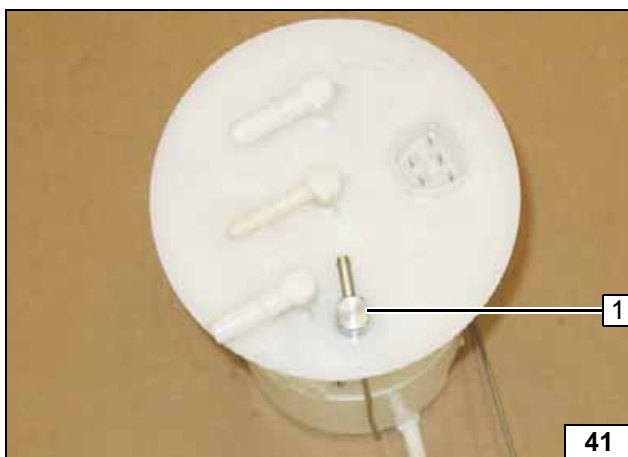

Shape fuel standpipe 1 according to template, cut to length and install



Installing fuel standpipe

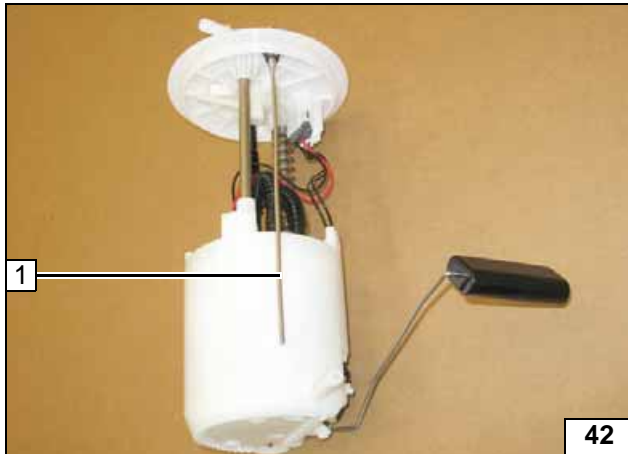
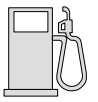

1 Fuel standpipe



Installing fuel standpipe

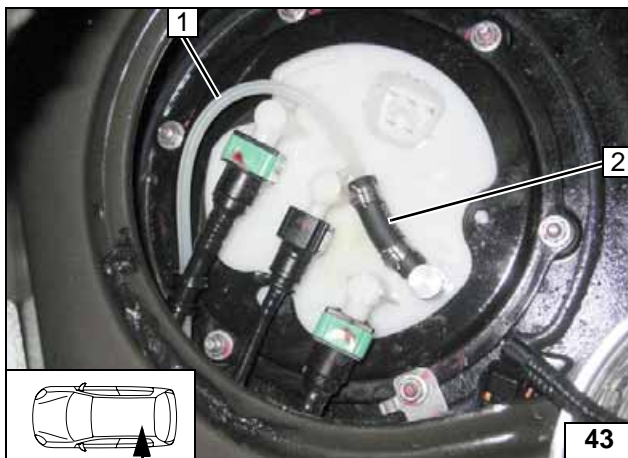

Install fuel-tank sending unit in accordance with manufacturer's instructions.

- 1 Fuel line
- 2 Hose section, 10 mm dia. hose clamps [2x]



Connecting fuel line

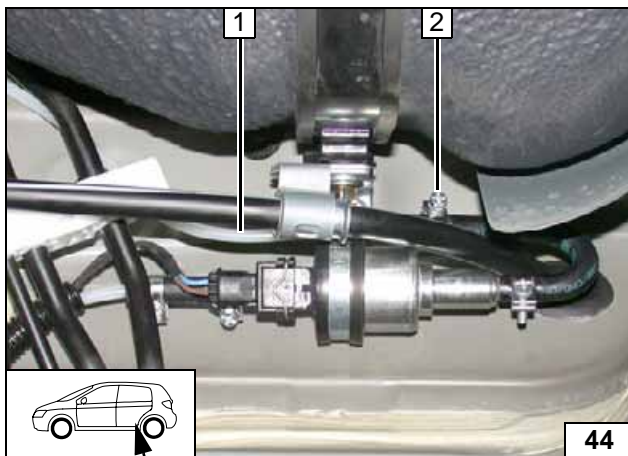

Check the position of the components; adjust if necessary. Check that they have free clearance.

- 1 Fuel line
- 2 10 mm dia. hose clamp



Connecting to metering pump

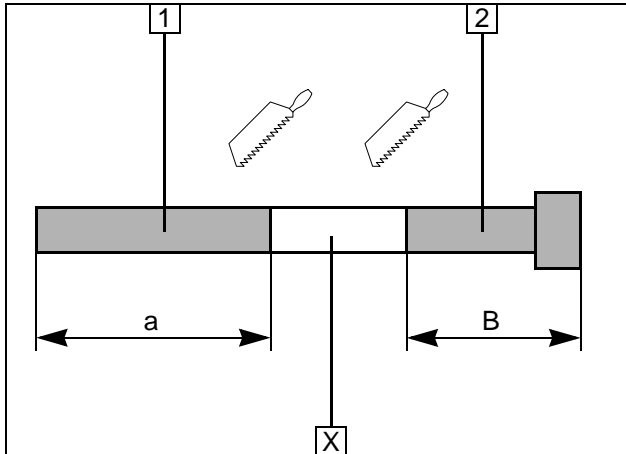
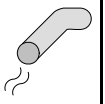

Exhaust system

- 1 Exhaust pipe
a = 490 mm
- 2 Exhaust end section
b = 190 mm

Discard section X

Preparing exhaust pipe

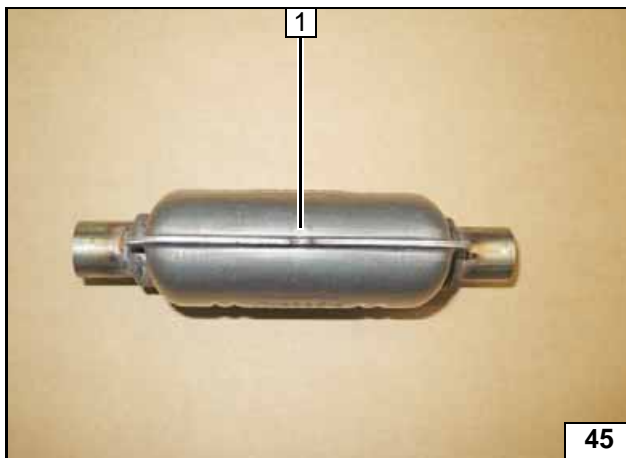

Pinch closed drain hole at position 1.



Closing drain hole

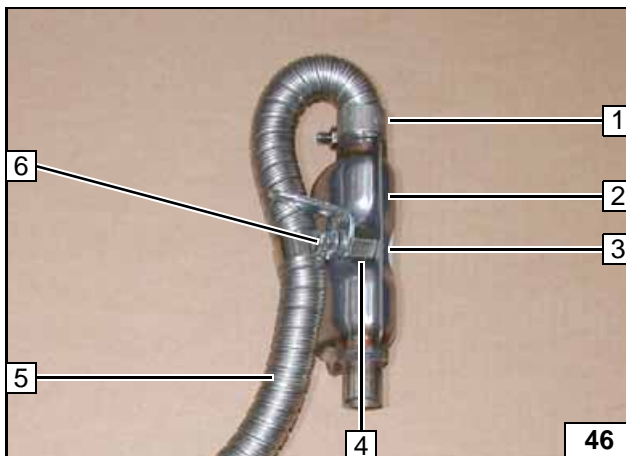

- 1 Hose clamp
- 2 Exhaust muffler
- 3 M6x30 bolt
- 4 Spacer nut, 15 mm
- 5 Exhaust pipe
- 6 Angle bracket, p-clamp, M6 flanged nut

Preassembling muffler, exhaust pipe

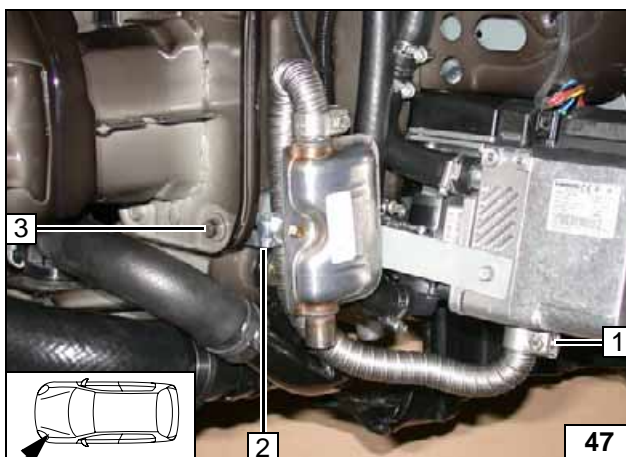

Ensure sufficient distance to neighboring components.
Remove original vehicle bolt at position 3 and discard.

- 1 Hose clamp
- 2 Angle bracket
- 3 M8x30 bolt, flanged nut

Installing exhaust pipe and muffler

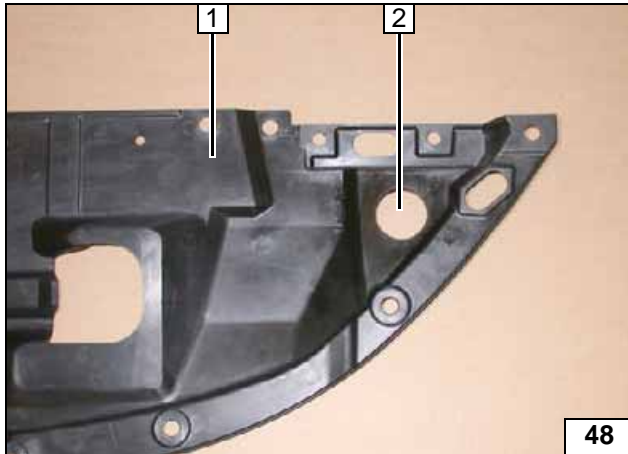
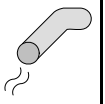

- 1 Underride protection
- 2 42 mm dia. hole

Cutting out
underride
protection

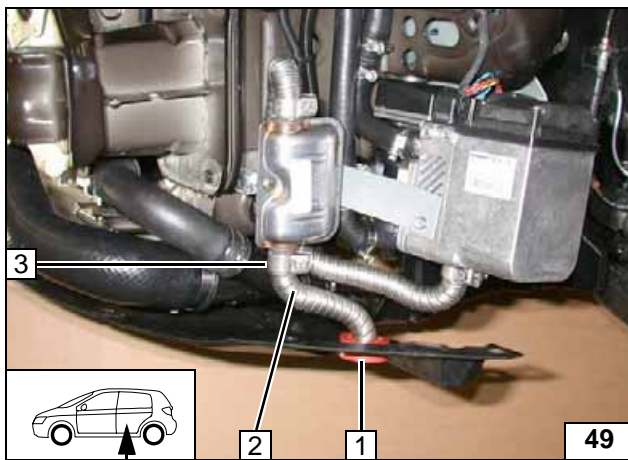

Insert red (rt) rubber isolator **1** in hole of underride protection. Route exhaust end section **2** through red (rt) rubber isolator **1** and align end flush.

- 3 Hose clamp



Position-
ing rubber
isolator

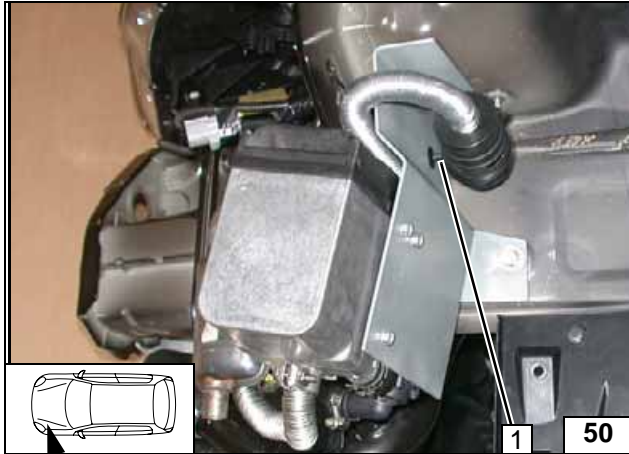
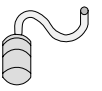

Combustion air

- 1 Retaining clip in hole

Installing retaining clip

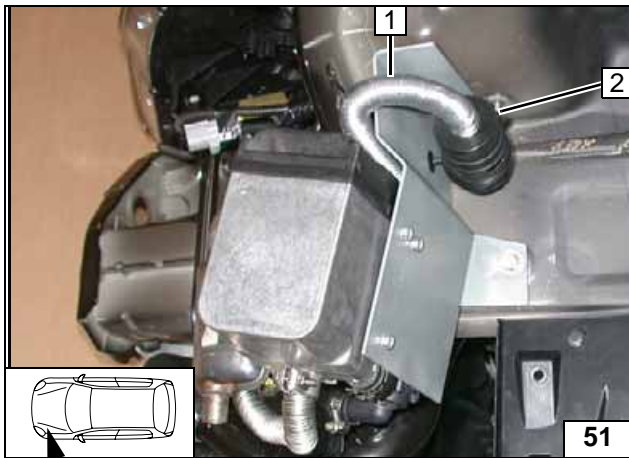

- 1 Combustion-air intake pipe
- 2 Combustion-air intake muffer in retaining clip



Installing muffer

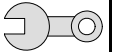

Final Work

WARNING!

Reassemble the disassembled components in reverse order.

Check all hoses, clamps and all electrical connections for firm seating.

Secure all loose cables using cable ties.

Only use manufacturer-approved coolant.

Spray the heater unit components with anti-corrosion wax (Tectyl 100K, Order No. 111329).

- Connect the battery
- Fill and bleed the coolant circuit according to the vehicle manufacturer's specifications.
- Set the digital timer.
- Set the manual air conditioning or automatic air conditioning according to the "operating instructions for the end customer".
- Check the proper operation of the additional heater, see the operating instructions/installation instructions.
- Attach the "Switch off additional heater before refueling" sticker to the left-hand B-pillar.

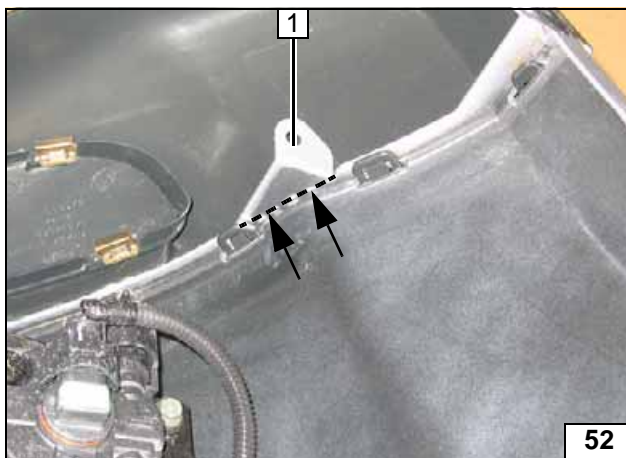

Cut away fastening tab 1 at marking and discard.



**Machining
bumper**

Webasto
Feel the drive

Webasto AG
Postfach 80 - 82132 Stockdorf
Hotline 01805 / 932278 - Hotfax 0395 / 5592-353
<http://www.webasto.de>

Operating Instructions for End Customer



Please remove page and add to the vehicle operating instructions.

Note:

We recommend matching the heating time to the driving time.

Heating time = driving time

Example:

For a driving time of approx. 20 min. (in one direction), we recommend not exceeding a switch-on time of 20 min.

If the summer/winter switch option has been installed, this must be switched in accordance with the time of year. The heater unit will then only switch on the vehicle fan to ventilate the vehicle interior in the position Winter heat and in the position Summer .

Before parking the vehicle, make the following settings:



- 1 Air outlet to windshield
- 2 Set temperature to "max."

**Automatic
air-condi-
tioning**

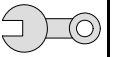

Template for Fuel Standpipe

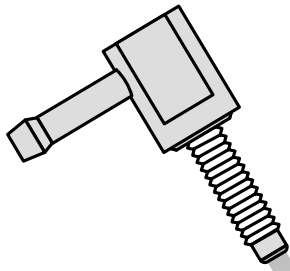

100 mm



Scale 1:1

Compare the size of the printed version with dimension lines.
Permitted tolerance a maximum of 2%.

Set the printer settings to "no margin" or "minimize margins" and 100% of the normal size.

100 mm

0

