

Water Heater Unit



Thermo Top E Additional Heater ^{e1} 00 0003

Thermo Top C Additional Heater ^{e1} 00 0002

Thermo Top P Additional Heater ^{e1} 00 0104

Installation Instructions

Mitsubishi Outlander

Gasoline

from Model Year 2007

Left-hand drive vehicle

Automatic air-conditioning



WARNING!

Hazard warning:

Incorrect installation or repair of Webasto heating systems may cause a fire or result in the emission of carbon monoxide, which can be fatal. Serious or fatal injuries can be caused as a result.

Specialist company training, technical documentation, specialized tools and equipment are required to install and repair Webasto heating and cooling systems.

NEVER attempt to install or repair Webasto heating or cooling systems if you have not successfully completed the company training and thereby acquired the required technical skills, or if you do not have access to the required technical documentation, tools and equipment needed to carry out correct installation and repairs.

ALWAYS follow all Webasto installation and repair instructions and observe all warnings.

Webasto does not accept any liability for defects and damage that are attributable to installation by untrained staff.

Table of Contents

Validity	2	Preparing heater unit	12
Heater Unit/Installation Kit	3	Preparing installation location	14
Foreword	3	Installing heater unit	14
General Instructions	3	Coolant	16
Special Tools	3	Fuel	18
Explanatory Notes on Document	4	Exhaust gas	21
Preliminary Work	5	Combustion air	22
Heater unit installation location	5	Final Work	23
Preparing electrical system	6	Operating Instructions for End Customer	24
Electrical Connections	7	Template for Bracket	25
Automatic air-conditioning fan controller	8	Template for Gasoline Fuel Standpipe	26
Remote option (Telestart)	10		
Remote option (Thermo Call)	11		

Validity

Manufacturer	Model	Type	EG-BE No./ABE
Mitsubishi	Outlander	CW	e1 * 2001/116 * 0406 * ...

Engine type	Engine model	Output in kW	Displacement in cm ³
4B12	Gasoline	125	2360

Vehicle and engine types, equipment variants and national specifications not listed in these installation instructions have not been tested. However, installation according to these installation instructions may be possible.

The installation location of a digital timer and summer/winter switch should be confirmed with the end customer before installation.

Heater Unit/Installation Kit

Quantity	Description	Order No.:
1	Retail accessories with desired heater control	See price list
1	Installation kit for Mitsubishi Outlander Gasoline	1313245A

Heater unit recommended for the respective vehicle class:

Vehicle	Heater unit
Compact car	Thermo Top E
Mid-size car, station wagon	Thermo Top C
Full-size car, van, offroader	Thermo Top P

The selection of the heater unit is based on the passenger compartment size of the vehicle and the level of comfort required by the customer!



Foreword

These installation instructions apply to Mitsubishi Outlander Gasoline vehicles - for validity, see page 2 - from model year 2007 and later, assuming technical modifications to the vehicle do not affect installation, any liability claims excluded. Depending on the vehicle version and equipment, modifications may be necessary during installation with respect to these installation instructions.

However, the stipulations in the "installation instructions" and "operating and maintenance instructions" for the *Thermo Top C/P/E* must always be observed.

The corresponding rules of technology and any information from the vehicle manufacturer should be observed during the installation work.

General Instructions

Installation should be carried out according to the general, standard rules of technology. Unless specified otherwise, fasten hoses, lines and wiring harnesses to original vehicle lines and wiring harnesses using cable ties.

Sharp edges should be fitted with edge protectors (split-open plastic hose).

Spray unfinished body areas, e.g. drilled holes, with anti-corrosion wax (Tectyl 100K, Order No. 111329).

Special Tools

- Torque wrench for 2.0 - 10 Nm
- Hose clamping pliers

Explanatory Notes on Document

To provide you with a quick overview of the individual working steps, you will find an identification mark on the outside top right corner of the page in question.

Mechanical system

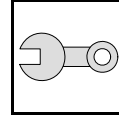

Electrical system

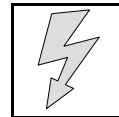

Water

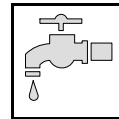

Fuel

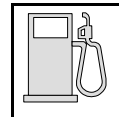

Exhaust gas

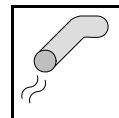

Combustion air

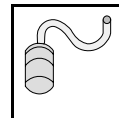

Special features are highlighted using the following symbols:



Specific risk of injury or fatal accidents.



Specific risk of damage to components.



Specific risk of fire or explosion.



Reference to general installation instructions of Webasto components or to the manufacturer's vehicle-specific documents.



Reference to a special technical feature.



The arrow in the vehicle icon indicates the position on the vehicle and the viewing angle.

All dimensions are in mm!

Tightening torque of hose clamps = 2.0 + 0.5 Nm!

Tightening torque of Ejet screws, Ejet studs = 10 Nm!

Preliminary Work

WARNING!

- Open fuel tank cap, ventilate tank.
- Close the tank cap again.
- Disconnect the battery "earth" or "ground" connection.
- Depressurize the cooling system.
- Copy the factory number from the original type label to the duplicate type label.
- Remove years that do not apply from the duplicate label.
- Attach the duplicate label (type label) in the appropriate place.
- Remove the battery.
- Remove the air filter together with the intake hose.
- Remove the engine control unit.
- Unhook the activated charcoal filter.
- Remove the windshield wipers
- Remove the coolant reservoir cap.
- Drain off the coolant.
- Remove the coolant hose of the engine outlet/heat exchanger inlet.
- Remove the left fuel tank cover.
- Remove the 3rd seat row (if installed)
- Fold back the floor covering.
- Open the tank-fitting service lid.
- Remove the fuel-tank sending unit in accordance with the manufacturers specifications.
- Remove the footwell trim on the driver's and front passenger side.
- Remove the instrument panel trim on the driver's side (only with Telestart).

Remove page 24 "Operating Instructions for End Customer" and add to the vehicle operating instructions.

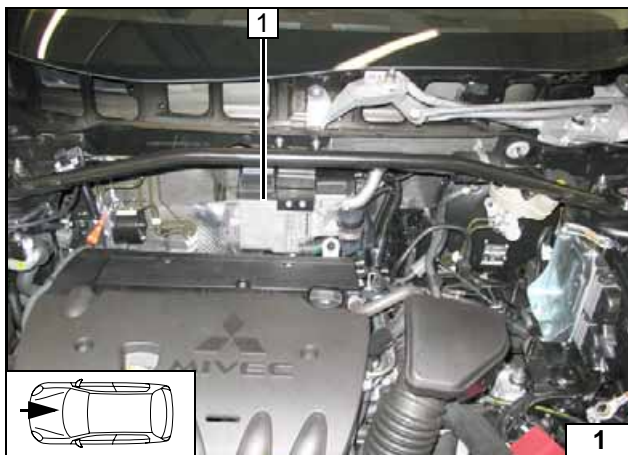

Heater unit installation location

- 1 Heater unit

Installation location



Preparing electrical system

Wire section 2 will be required later for connecting the IPCU/A!

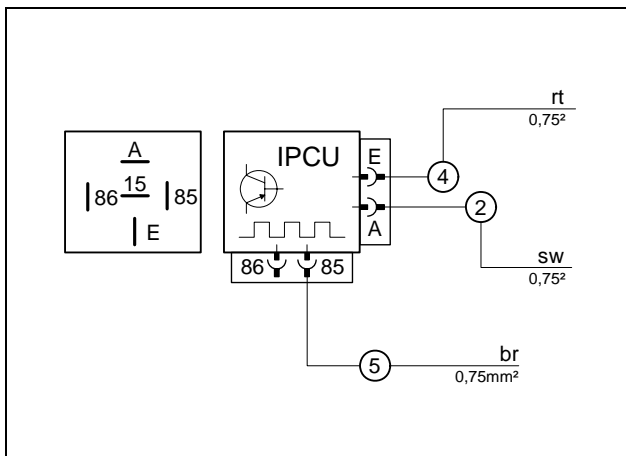
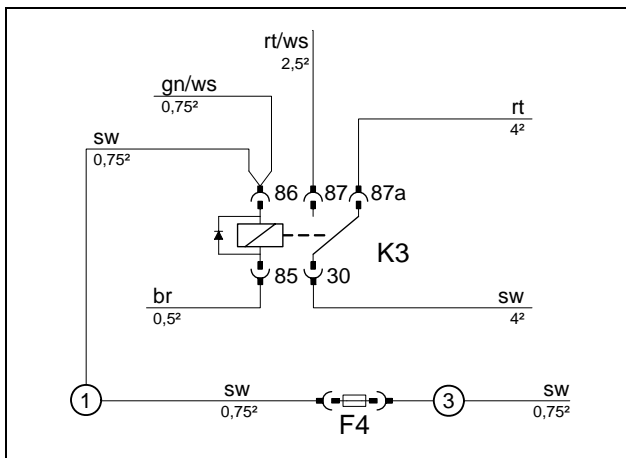
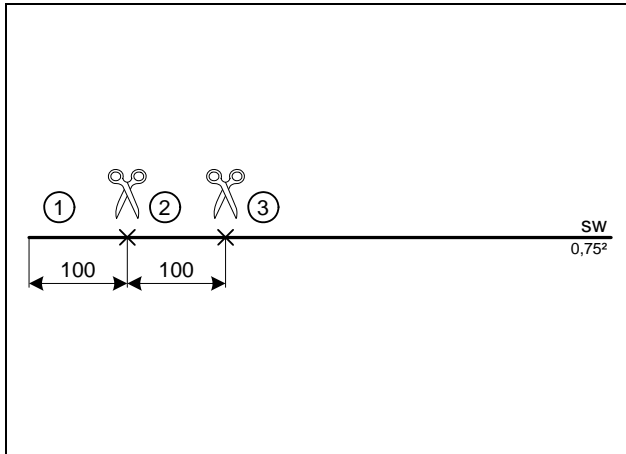

Produce connections as shown in wiring diagram. Route wire section 3 together with wiring harnesses of heater unit, fan controller, metering pump and digital timer in 17 mm dia. corrugated hose.

The preprogrammed data of the IPCU are mean values which can differ in individual cases. This is specified in dependence on the design by the fan module of the vehicle. If the fan output is too low or high, the IPCU can be reprogrammed with the Webasto diagnostic system. Change voltage in 0.1 V steps. Measure current consumption on blue/white (bl/ws) wire of fan motor. Comply with value < 6 A!

- Duty cycle:** 100 %
- Frequency:** 14 kHz
- Voltage:** 4.2 V
- Function:** High-side



Cutting wires to length



Preparing fuse F4



Preassembling IPCU



Electrical Connections

Wiring harness pass through

- 1 Protective rubber plug
- 2 Wiring harnesses of fan controller and digital timer, black (sw) wire from F4

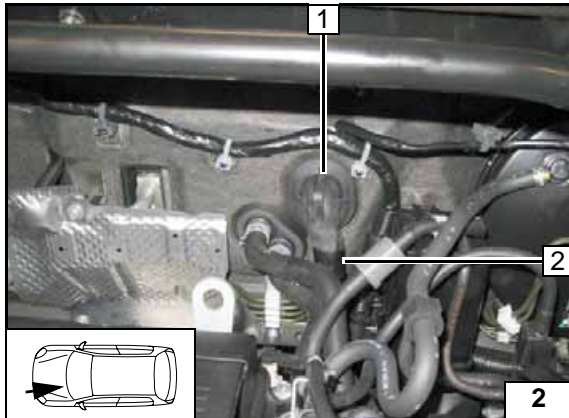

Digital timer and summer/winter switch option

- 1 Summer/winter switch, drilled hole 12 mm dia.
- 2 Digital timer

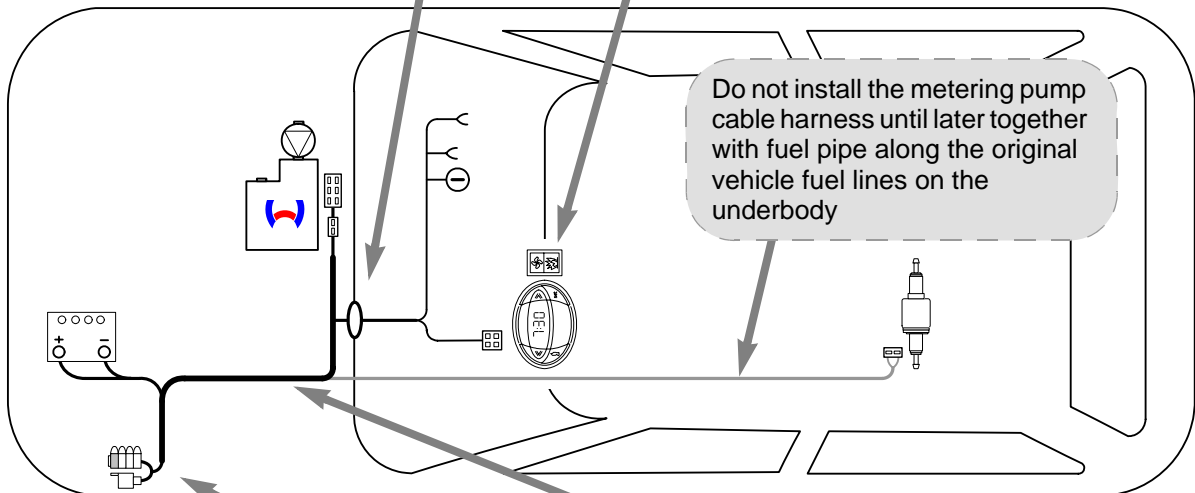

Wiring harness installation diagram

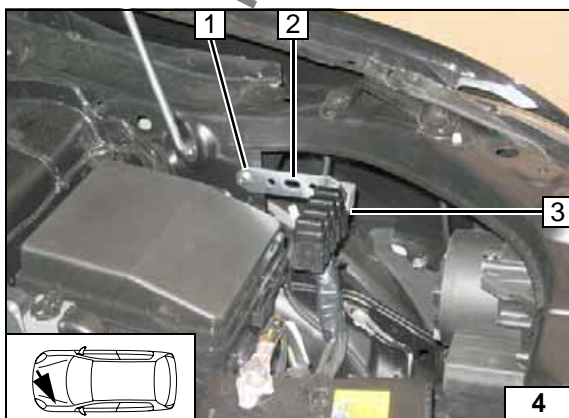

Fuse holder, relay K3

- 1 Mount M6x20 bolt, flanged nut in existing hole
- 2 Perforated bracket
- 3 Retaining plate of fuse holder, M5x16 bolt, fuse holder [4x], relay K3, washer, flanged nut on perforated bracket

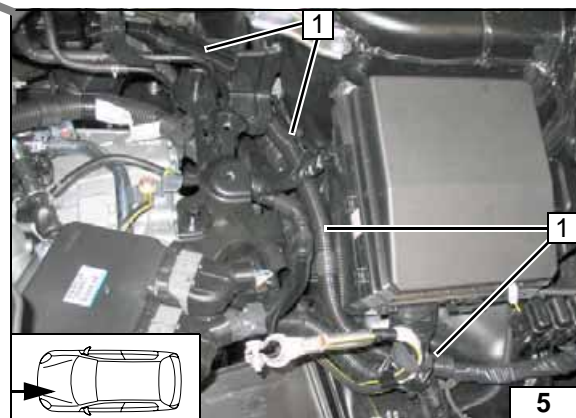

Wiring harness routing

- 1 Wiring harness of heater unit, fan controller, digital timer, metering pump, additional line from F4 in 17 mm dia. corrugated tube



Automatic air-conditioning fan controller

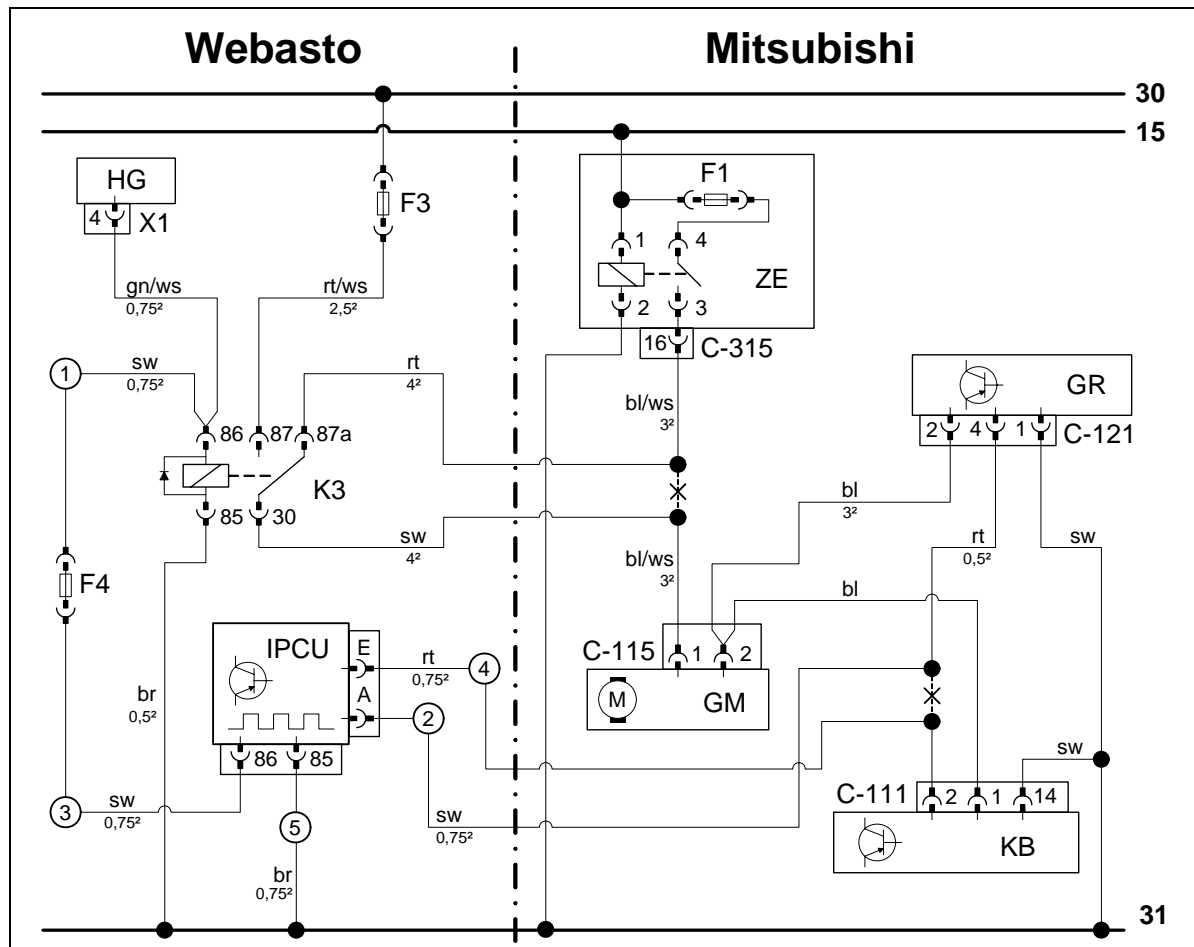

Wiring diagram

Webasto components		Vehicle components		Colors and symbols	
HG	Heater unit TT-C/E	GM	Fan motor	rt	red
X1	6-pin connector	C-115	2-pin connector GM	ws	white
F3	25 A fuse	GR	Fan controller	sw	black
F4	1 A fuse	C-121	4-pin connector GR	br	brown
K3	Fan relay	KB	Air-conditioning control panel	gn	green
IPCU	Pulse width modulator	C-111	20-pin connector KB	bl	blue
IPCU adjustment values:		C-315	19-pin connector ZE		
Duty cycle: 100 %		F1	Fuse 30A		
Frequency: 14 kHz					
Voltage: 4.2 V				X	Cutting point
Function: High-side				Wiring colors may vary.	

Legend

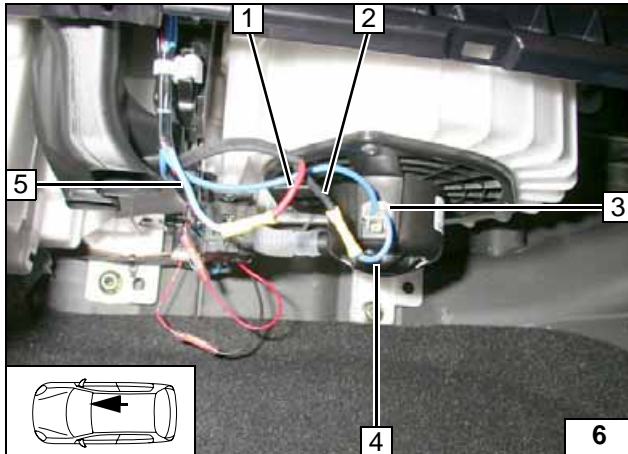

Connection to 2-pin connector C-115 3 from blower motor. Produce connections as shown in wiring diagram.

- 1 Red (rt) wire from K3/87a
- 2 Black (sw) wire from K3/30
- 4 Blue/white (bl/ws) wire of connector C-115
- 5 Blue/white (bl/ws) wire of fan relay in central electrical box



**Connect-
ing fan-mo-
tor**

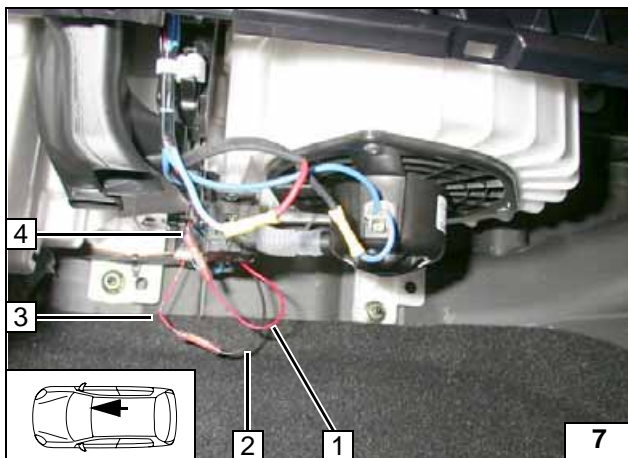

Connect black (sw) wire section 2 to IPCU/A. Produce connections as shown in wiring diagram.

- 1 Red (rt) wire of IPCU/E
- 2 Black (sw) wire of IPCU/A
- 3 Red (rt) wire of fan controller
- 4 Red (rt) wire of A/C control panel



**Connect-
ing IPCU**

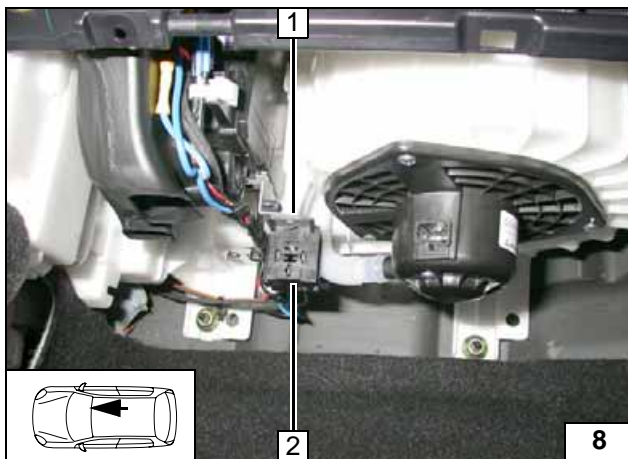

- 1 Original vehicle bolt
- 2 IPCU socket

**Installing
IPCU**

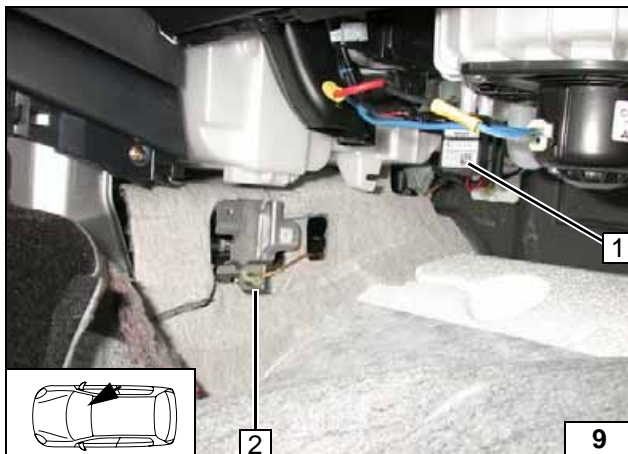

Produce connections as shown in wiring diagram.

- 1 Connect IPCU
- 2 Brown (br) wire of IPCU/85 on original vehicle ground point



**Connect-
ing ground
wire**

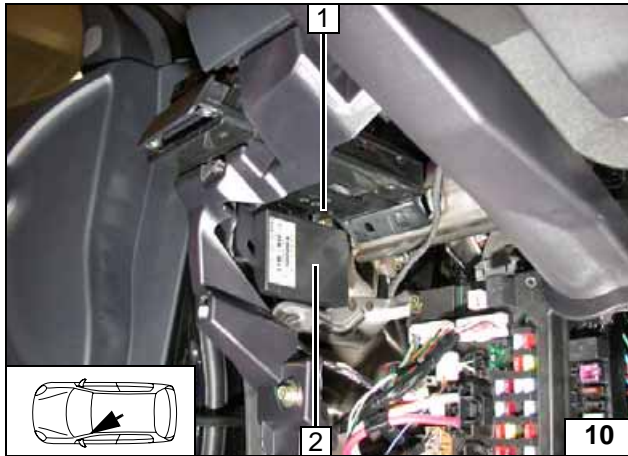

Remote option (Telestart)

- 1 Mount M5x16 bolt, bracket, flanged nut in existing hole
- 2 Receiver



Installing receiver

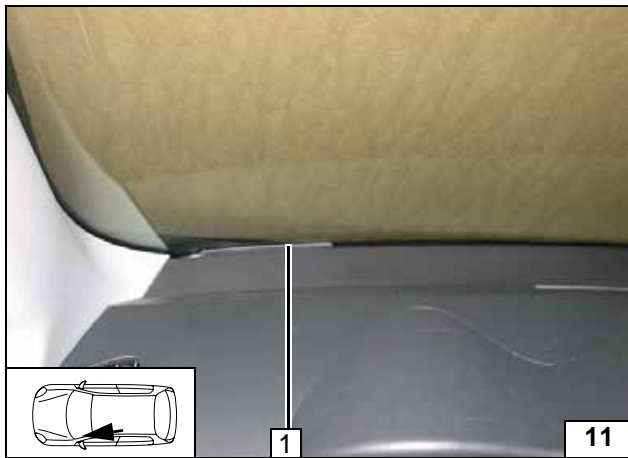

- 1 Antenna

Installing antenna

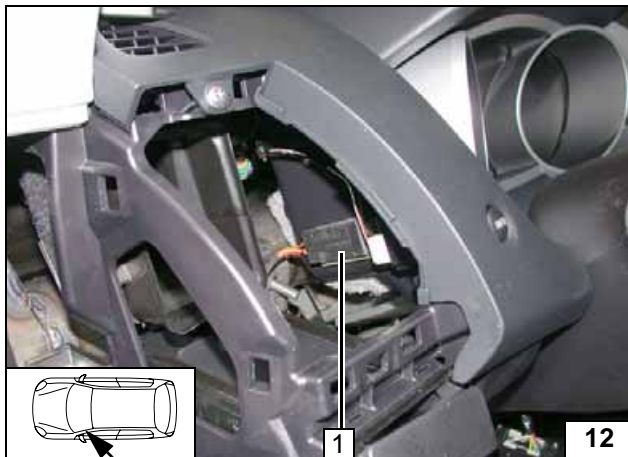

Temperature sensor for HTM100 only

- 1 Fasten temperature sensor with suitable means

Installing temperature sensor

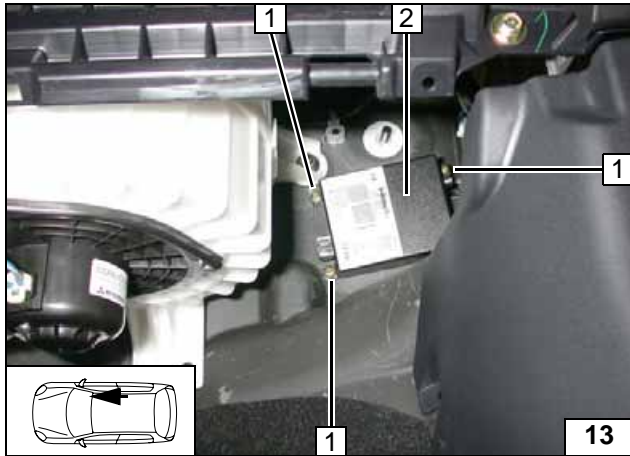

Remote option (Thermo Call)

- 1 5.5x9.5 self-tapping screws [4x]
- 2 Receiver



Installing receiver

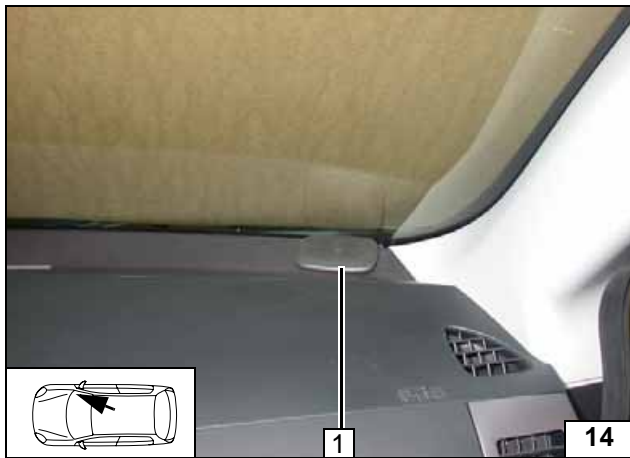

- 1 Antenna

Installing antenna



- 1 Pushbutton

Installing push button

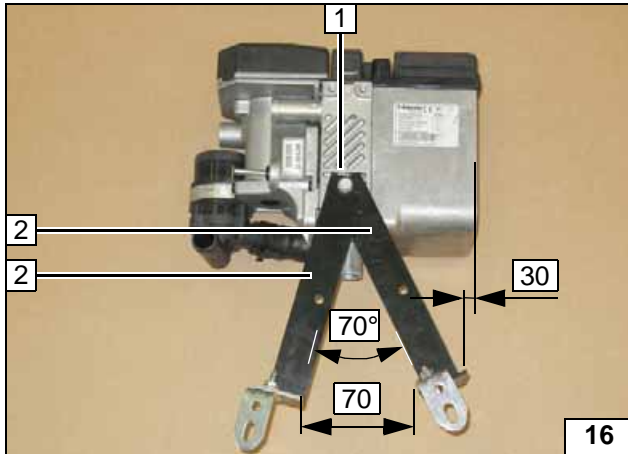
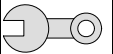

Preparing heater unit

- 1 E-jot screw
- 2 Strut [2x]

Premounting strut on heater unit

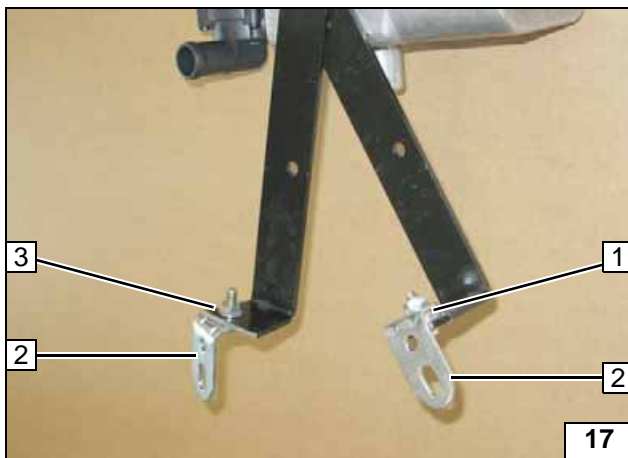

- 1 M6x20 bolt, 5 mm shim, flanged nut
- 2 Angle bracket [2x]
- 3 M6x20 bolt, flanged nut

Installing angle bracket on struts



- 1 Fuel line
- 2 Hose section, 10 mm dia. clamp [2x]

Premounting fuel hose on heater unit

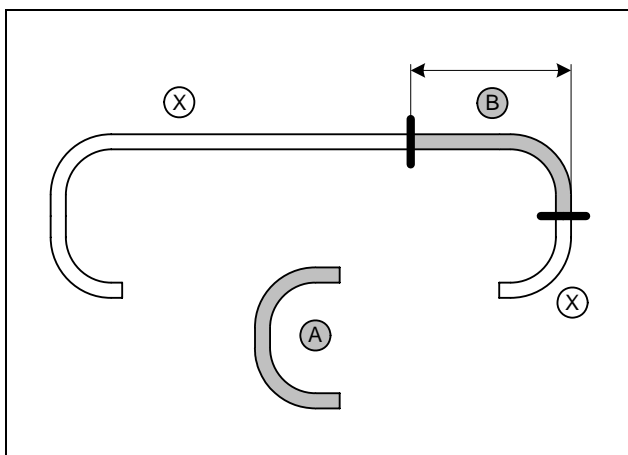

b = 110

Hose A = 20x15 180° elbow provided
Discard section X

Cutting coolant hoses to length

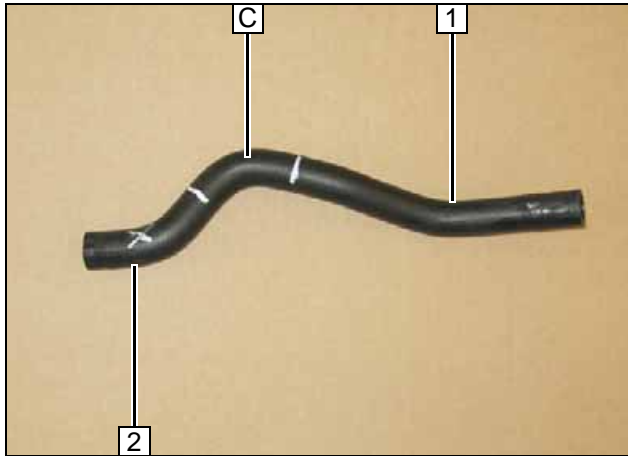

- 1 Remount hose section of engine outlet
- 2 Discard section



Cutting removed coolant hose to length

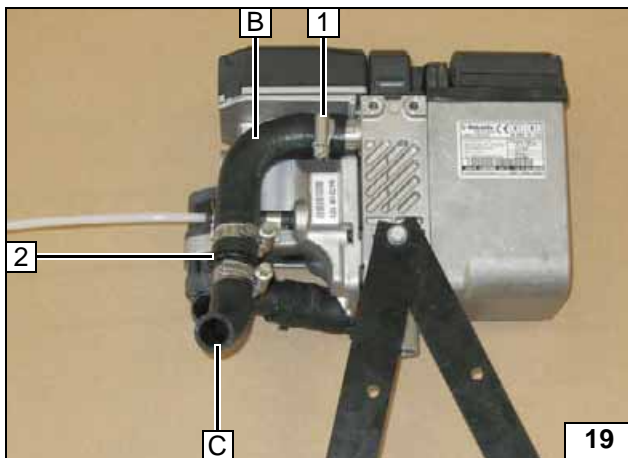

- 1 27 mm dia. clamp
- 2 17x20 connecting pipe, 27 mm dia. clamp [2x]

Premounting coolant hoses

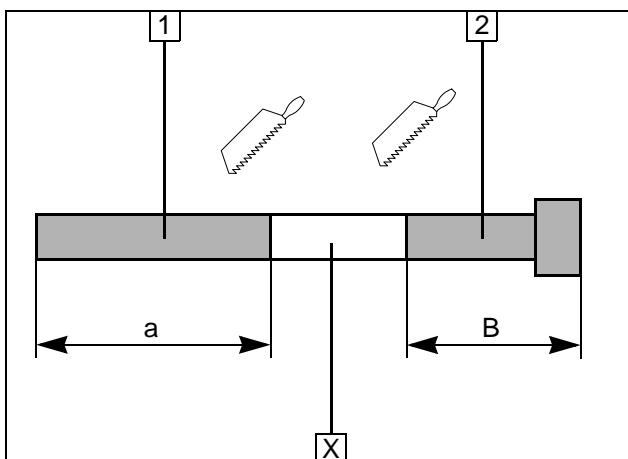

- 1 Exhaust pipe
a = 800
- 2 Exhaust end section
b = 90

Discard section X

Preparing exhaust pipe

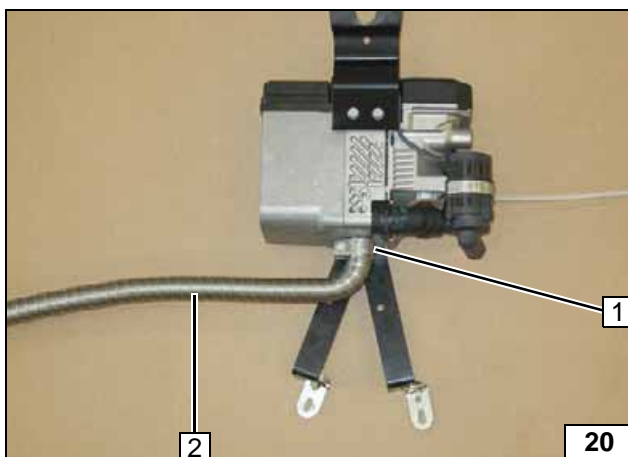

- 1 Hose clamp
- 2 Exhaust pipe

Preassembling exhaust pipe

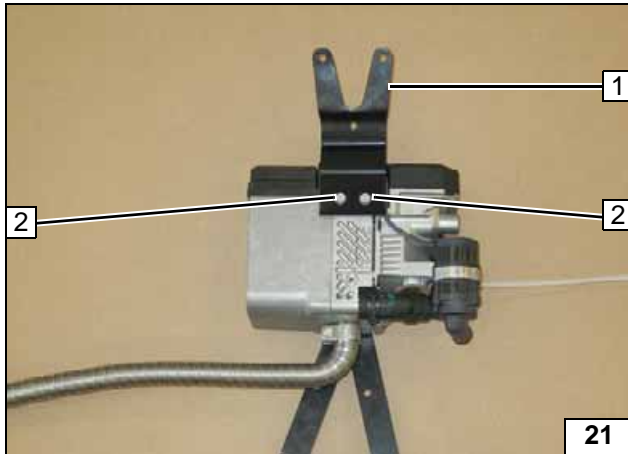
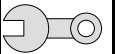

Cut bracket 1 to length and bend in accordance with template.

2 E-jot screw [2x]



Preassembling bracket on heater unit

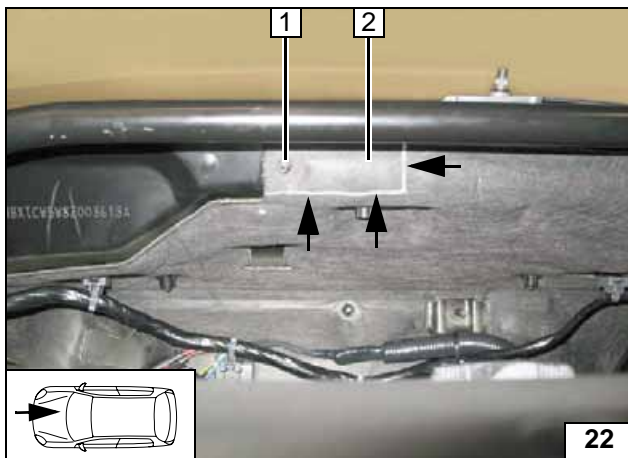

Preparing installation location

Cut out insulation 2 at marking and discard.

1 Original vehicle stud bolt for fastening bracket



Cutting out insulation

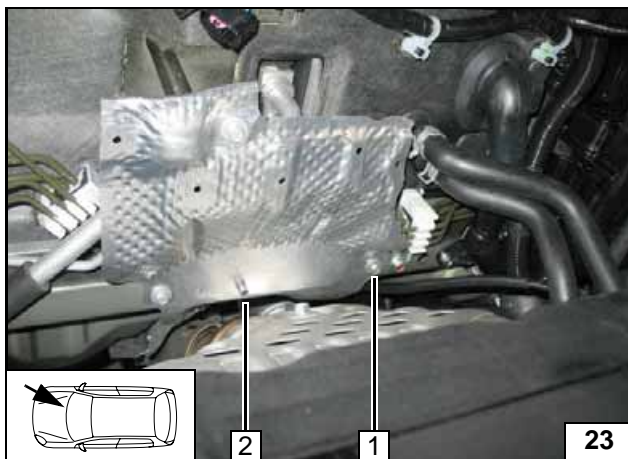

Remove original vehicle bolt, large diameter washer 1; will be reused.

2 Original vehicle M8 stud bolt for fastening bracket



Removing bolt

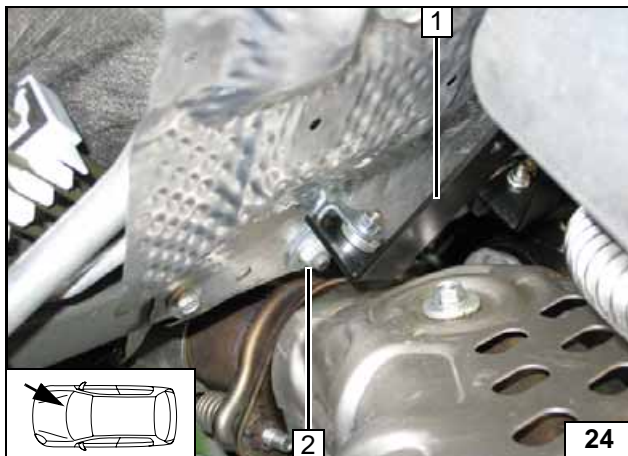

Installing heater unit

1 Strut

2 M8 flanged nut on original vehicle stud bolt

Installing heater unit

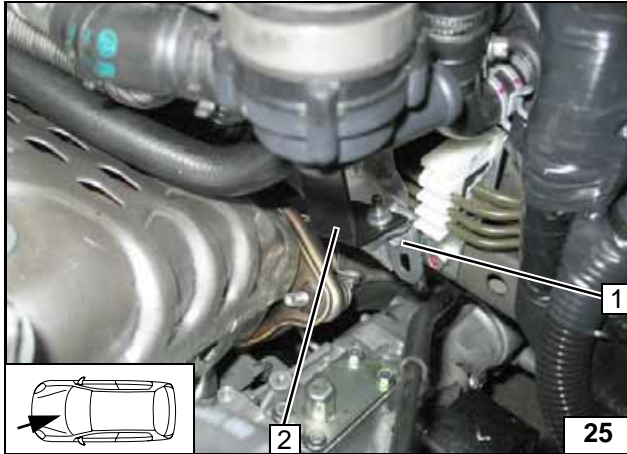
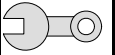

- 1 Original vehicle bolt, large diameter washer
- 2 Strut

Installing heater unit

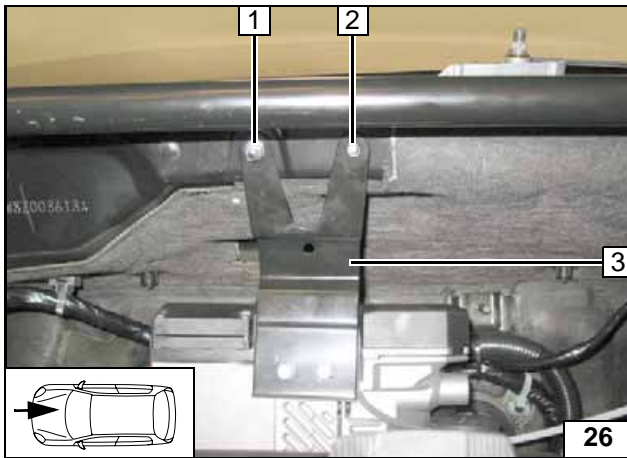

Align heater unit. Copy hole pattern at position 2. 7 mm dia. hole in coolant reservoir.



- 1 Flanged nut on original vehicle stud bolt
- 3 Bracket

Hole in coolant reservoir

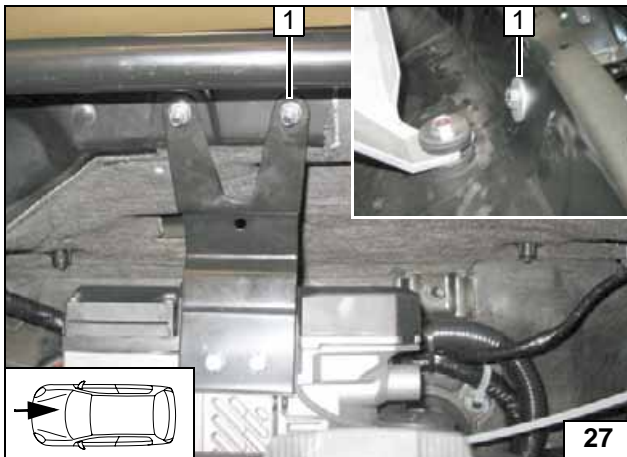

- 1 M6x20 bolt, large diameter washer, flanged nut

Installing heater unit

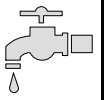

Coolant

WARNING!

Any coolant running off should be collected using an appropriate container. Install hoses so that they are kink-free. Unless specified otherwise, always fasten using cable ties. Position clamps so that no other hose can be damaged! When installing the coolant hose, the heater unit must be filled with coolant.

The connection should be "inline" based on the following diagram:

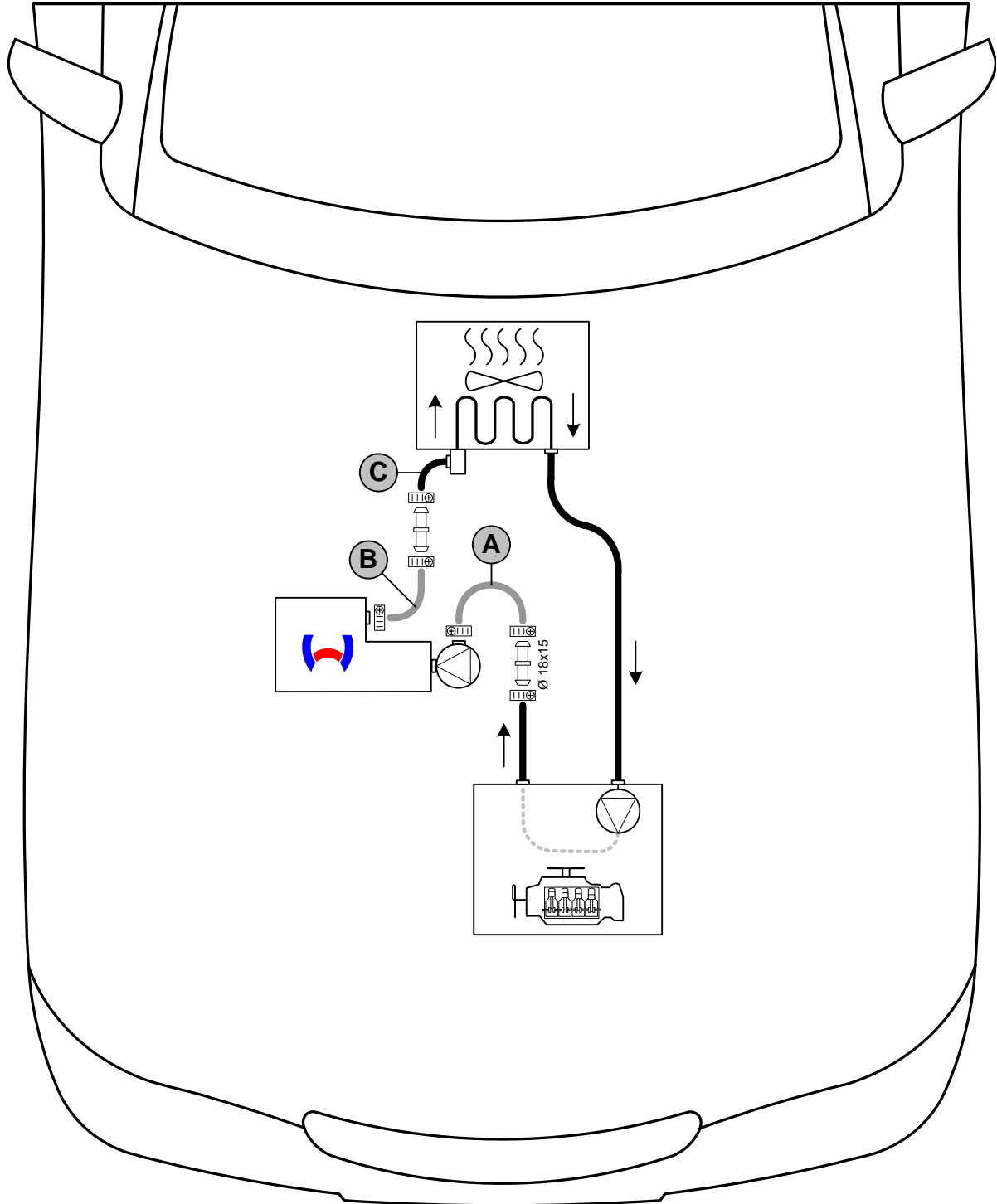

Coolant routing diagram

Undesignated connecting pipe (□□) = dia. 17x20.
All hose clamps (⊗□□) = 20-27 mm dia.!





1 Original vehicle spring clip

Connect-
ing heat
exchanger
inlet

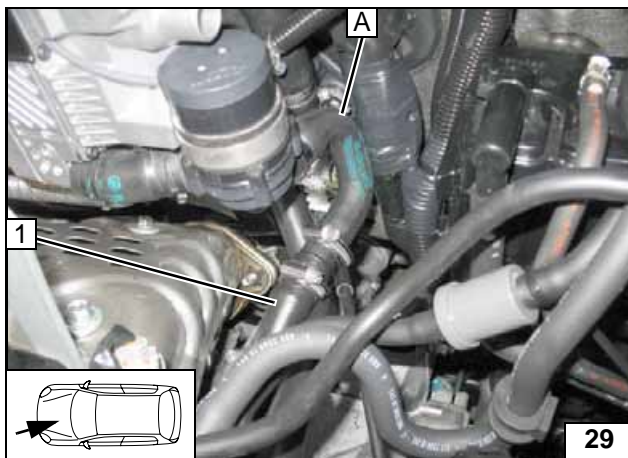

Install hose **A** with 20 mm dia. hose end on heater unit inlet.

1 Hose of engine outlet

Connect-
ing engine
outlet

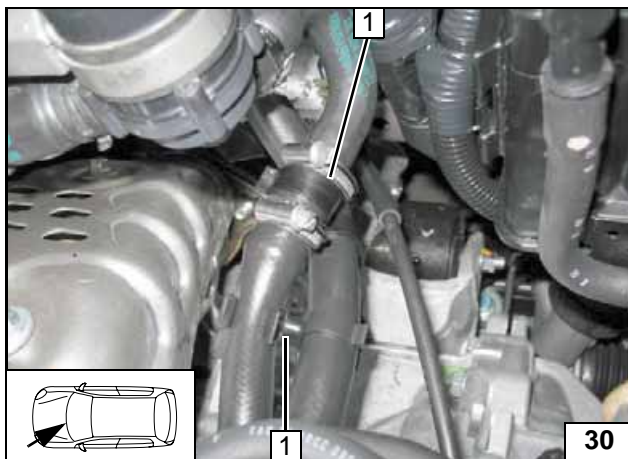

1 Spacer bracket [2x]

Install-
ing
spacer
bracket



Fuel

CAUTION!

Open the vehicle's fuel tank cap, ventilate the tank and then re-close the tank lock.

Catch any fuel running off with an appropriate container.

Install fuel line and metering-pump wiring harness so that they are protected against stone impact. Unless specified otherwise, always fasten using cable ties. Mount the fuel line and wiring harness with rub protection on sharp edges.

WARNING!

The fuel line and wiring harness are routed to the metering pump in as shown in the wiring harness routing diagram.



**Connect-
ing heater
unit**

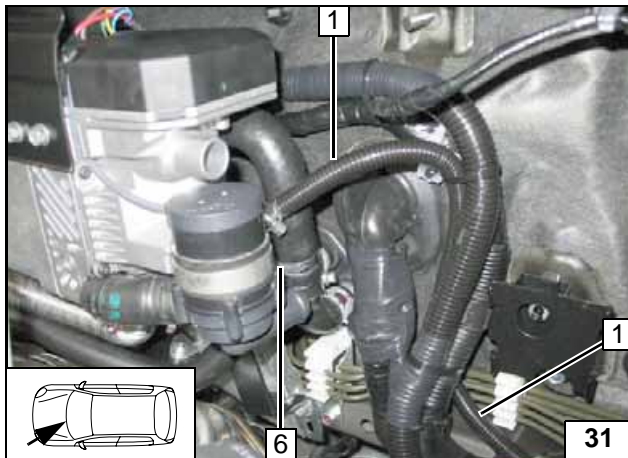

Fuel line 1 from heater unit in 10 mm dia. corrugated tube (2,100 mm).



**Installing
lines**



Fuel line and wiring harness of metering pump 1 from center of firewall in 10 mm dia. corrugated tube (2,100 mm).

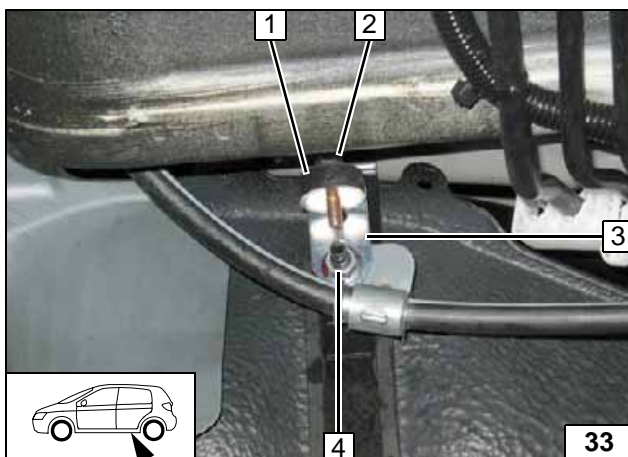

- 1 Silent block on angle bracket
- 2 Flanged nut
- 3 Angle bracket
- 4 Original vehicle stud bolt of fuel tank mounting

**Installing
angle
bracket**

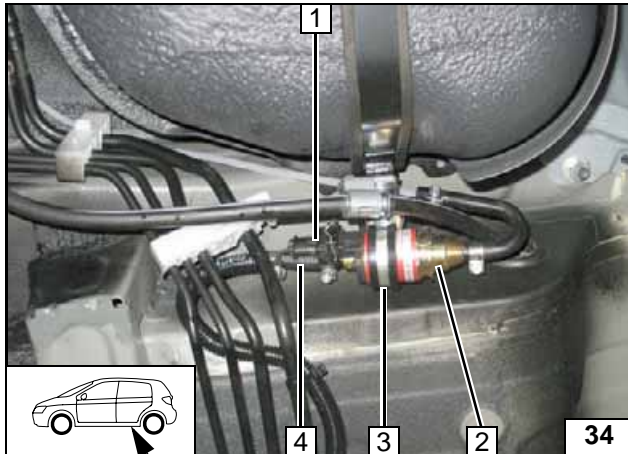
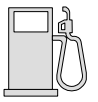

- 1 Wiring harness of metering pump, connector mounted
- 2 Metering pump
- 3 Rubber-coated p-clamp, flanged nut on silent block
- 4 Fuel line, hose section, 10 mm dia. clamp [2x]



Installing metering pump

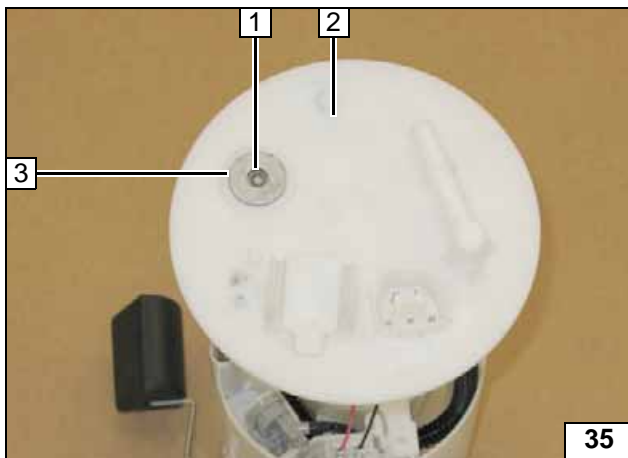

Remove fuel-tank sending unit 2 in accordance with manufacturer's instructions.

- 1 Copy hole pattern, 6 mm dia. hole
- 3 Large diameter washer centered in cut-out



Removing fuel

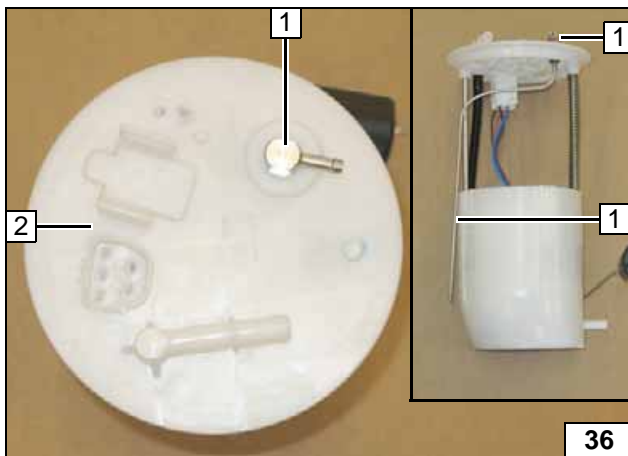

Shape fuel standpipe 1 according to template, cut to length and install.

- 2 Fuel-tank sending unit



Installing fuel standpipe

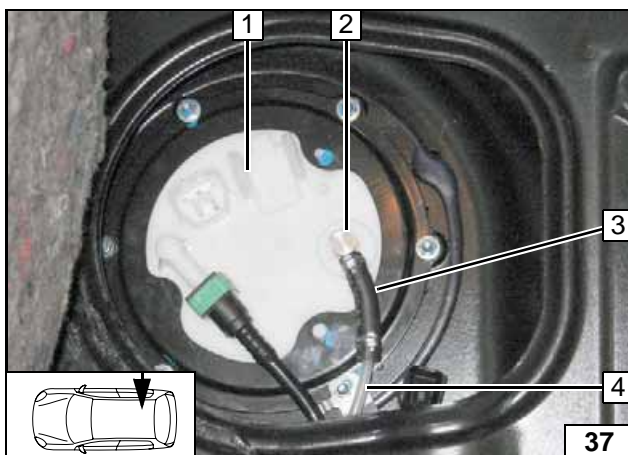

Install fuel-tank sending unit 1 in accordance with manufacturer's specifications.

- 2 Fuel standpipe
- 3 Hose section, 10 mm dia. Caillau clamp [2x]
- 4 Fuel line



Connecting fuel line

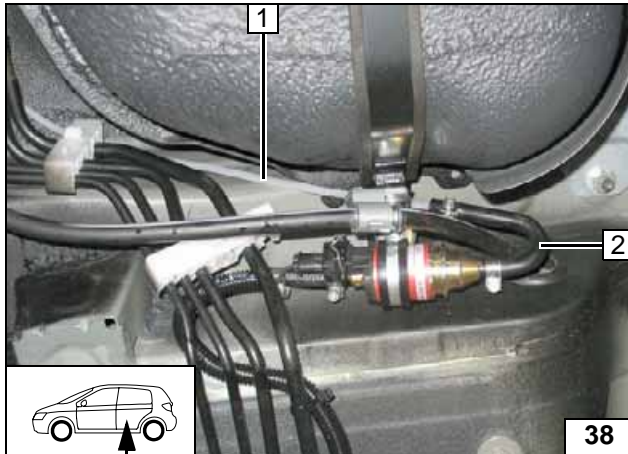
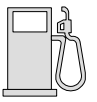

Check the position of the components; adjust if necessary. Check that they have free clearance.

- 1 Fuel line
- 2 180° molded hose, 10 mm dia. clamp [2x]



**Connect-
ing meter-
ing pump**

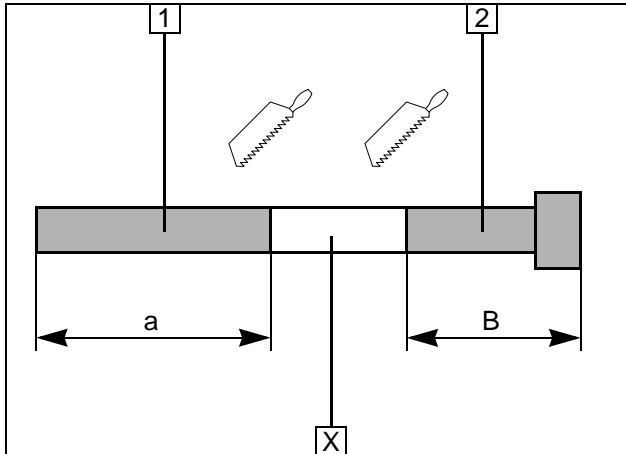
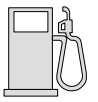

Exhaust gas

- 1 Exhaust pipe
a = 800
- 2 Exhaust end section
b = 90

Discard section X

Preparing exhaust pipe

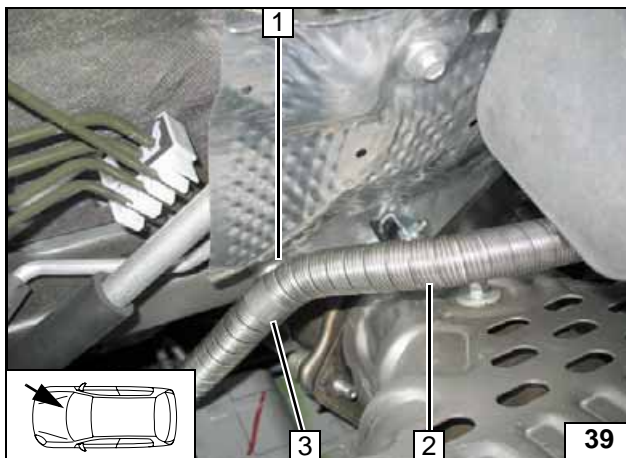

Remove existing bolt at position 1.

- 2 Exhaust pipe
- 3 M6x25 bolt, p-clamp, 10 mm shim on existing threaded hole



Installing exhaust pipe

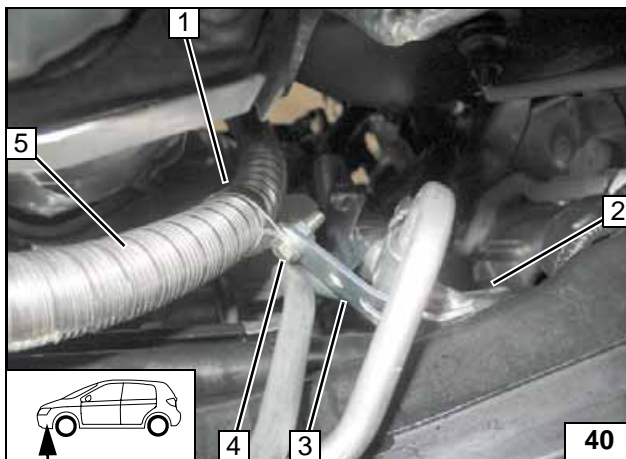

Bend perforated bracket 3 as shown and also fasten on original vehicle bolt of bracket for A/C line 2.

Shape and align exhaust pipe 5. Ensure sufficient distance to neighboring components.

- 1 P-clamp
- 4 M6x20 bolt, flanged nut on perforated bracket



Installing exhaust pipe

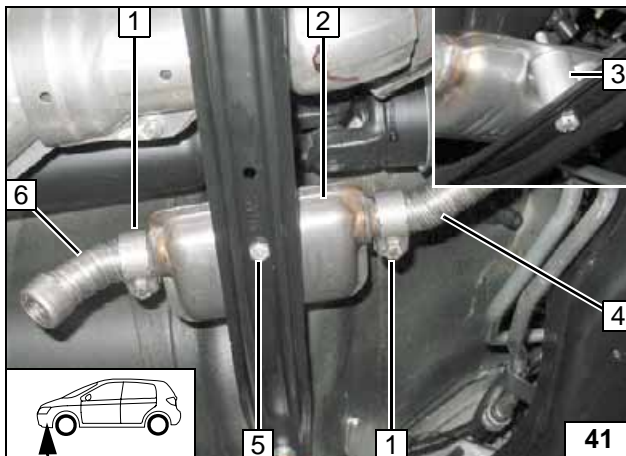

- 1 Hose clamp [2x]
- 2 Muffler
- 3 30 mm shim
- 4 Exhaust pipe
- 5 M6x50 bolt, flanged nut
- 6 Exhaust end section

Installing muffler and exhaust end section

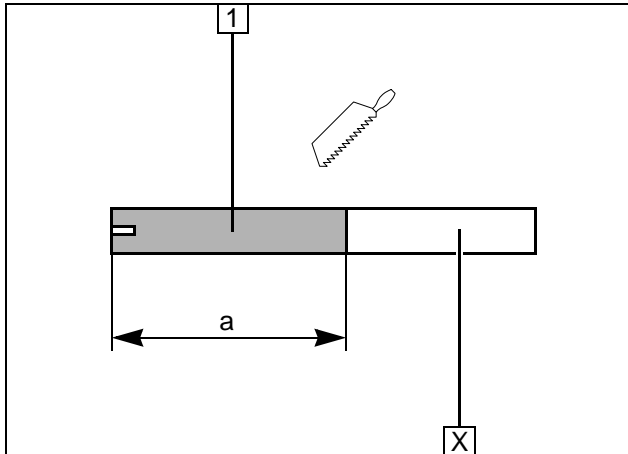
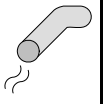

Combustion air

- 1 Combustion air pipe
a = 300

Discard section X

Cutting combustion air pipe to length

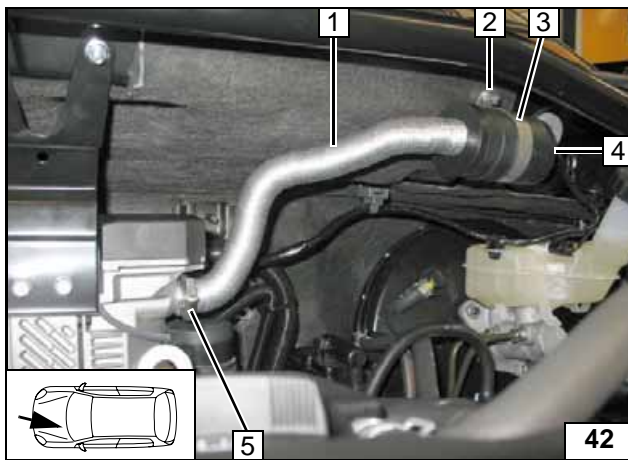

- 1 Combustion air pipe
- 2 Flanged nut on original vehicle stud bolt
- 3 52 mm dia. clamp
- 4 Muffler
- 5 27 mm dia. clamp



Installing combustion air pipe and muffler

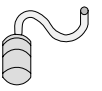

Final Work

WARNING!

Reassemble the disassembled components in reverse order.

Check all hoses, clamps and all electrical connections for firm seating.

Secure all loose cables using cable ties.

Only use manufacturer-approved coolant.

Spray the heater unit components with anti-corrosion wax (Tectyl 100K, Order No. 111329).

- Connect the battery
- Fill and bleed the coolant circuit according to the vehicle manufacturer's specifications.
- Set the digital timer.
- Make settings on A/C control panel according to the "Operating Instructions for End Customer".
- Check the proper operation of the additional heater, see the operating instructions/installation instructions.
- Attach the "Switch off additional heater before refueling" sticker to the left-hand B-pillar.



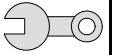

Operating Instructions for End Customer



Please remove page and add to the vehicle operating instructions.



Note:

We recommend matching the heating time to the driving time.

Heating time = driving time

Example:

For a driving time of approx. 20 min. (in one direction), we recommend not exceeding a switch-on time of 20 min.

If the summer/winter switch option has been installed, this must be switched in accordance with the time of year. The heater unit will then only switch on the vehicle fan to ventilate the vehicle interior in the position Winter  heat and in the position Summer .

Before parking the vehicle, make the following settings:



- 1 Air outlet to windshield
- 2 Set temperature to "max."

Automatic
air-condi-
tioning

Webasto
Feel the drive

Webasto AG
Postfach 80 - 82132 Stockdorf
Hotline 01805 / 932278 - Hotfax 0395 / 5592-353
<http://www.webasto.de>

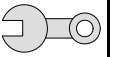

Template for Bracket

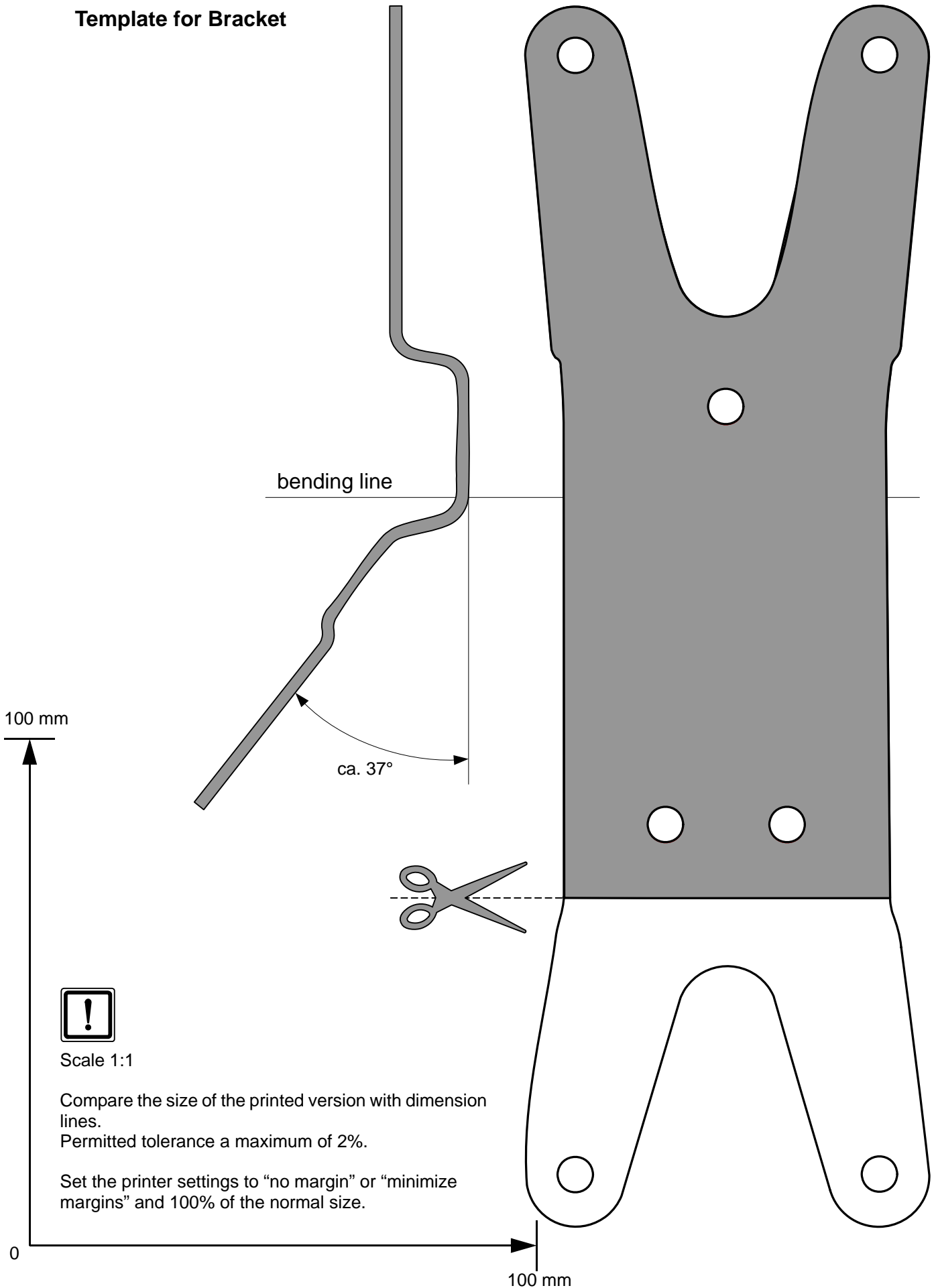

Scale 1:1

Compare the size of the printed version with dimension lines.
Permitted tolerance a maximum of 2%.

Set the printer settings to "no margin" or "minimize margins" and 100% of the normal size.

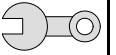

Template for Gasoline Fuel Standpipe

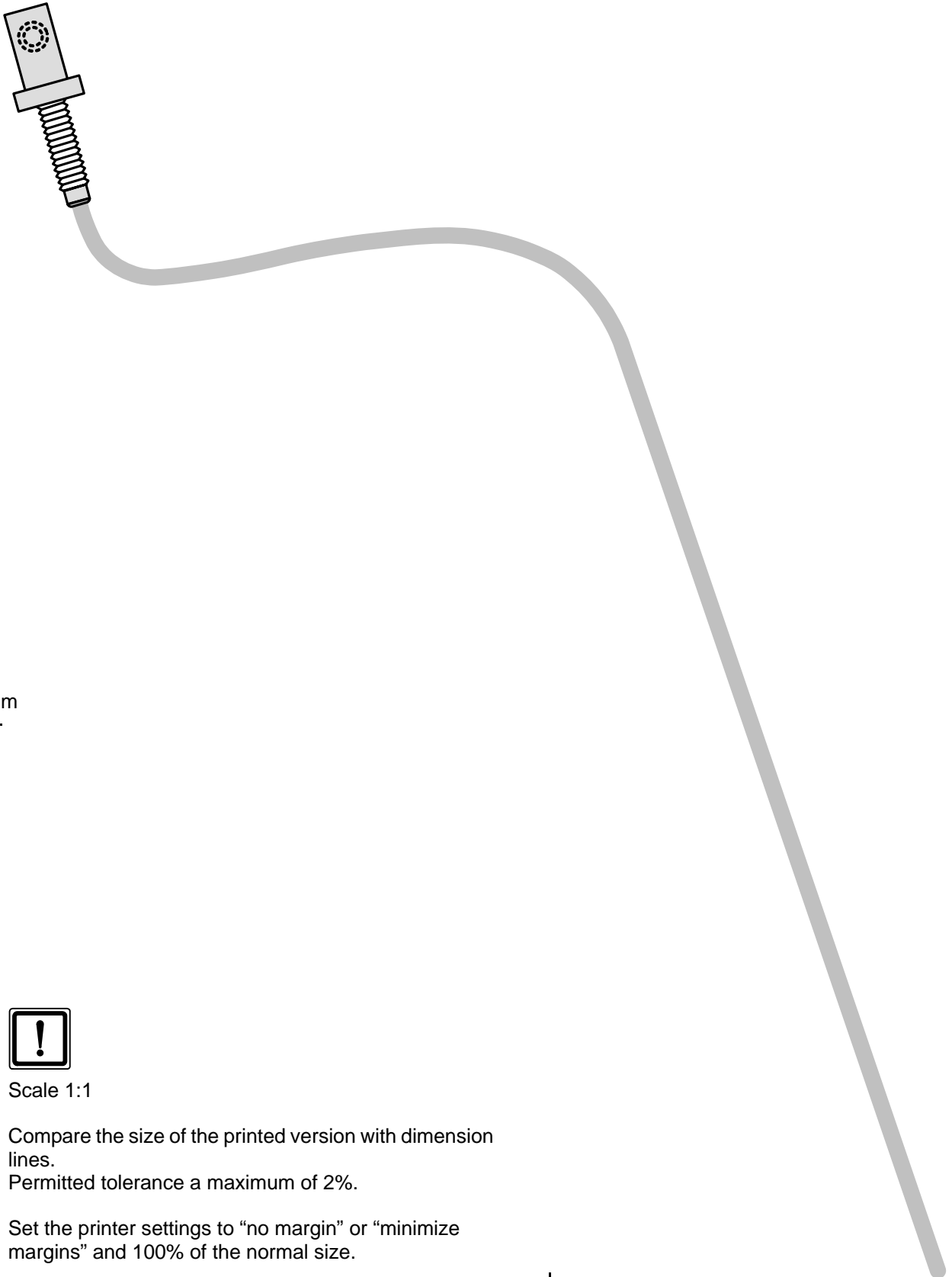

100 mm



100 mm



Scale 1:1

Compare the size of the printed version with dimension lines.
Permitted tolerance a maximum of 2%.

Set the printer settings to "no margin" or "minimize margins" and 100% of the normal size.